

CarrLane[®]

M A N U F A C T U R I N G C O.



CATALOG LXIII

www.carrlane.com

Authorized Distributor

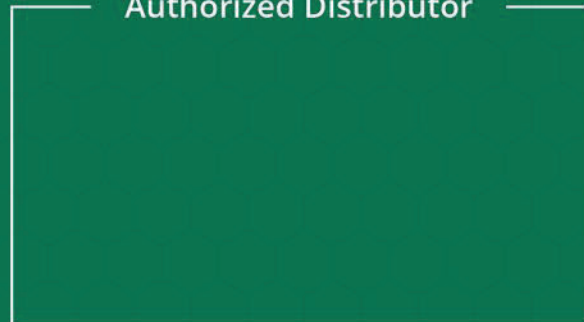

Engineering Resources

carrlane.com/engineeringresources



Online Trig
Book



Request for Quote
(RFQ) Information



Technical
Information



Fixture Design
Principles

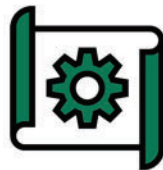

Material & Finish
Information



Compliance
Statements



Safety



CAD Drawings











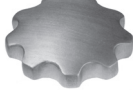

engineering@carrlane.com

+1.314.647.6200

ISO 9001:2015
CERTIFIED

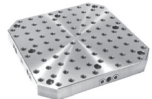
CATALOG SECTIONS

Pictorial Index p. 4-15; Alphabetical Index p. 16-25

	Alignment Pins..... 27-72	1
	Hoist Rings..... 73-92	2
	Handles, Knobs, and Screw Clamps..... 93-160	3
	Spring-Loaded Devices 161-198	4
	Supports, Rests, and Feet..... 199-233	5
	Locators 234-257	6
	Clamps and Accessories 258-341	7
	Threaded Fasteners 342-353	8
	Jig and Fixture Bases 354-401	9
	Modular Fixturing..... 402-437	10
	Toggle Clamps..... 438-512	11
	Stage and Film..... 513-514	12
	Drill-Jig Bushings 515-586	13
	ROEMHELD Power Workholding 587-720	14

NEW

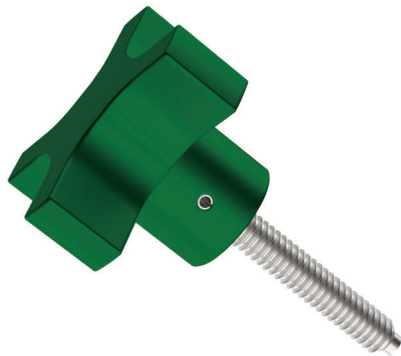

Extruded Hand Knob Assemblies

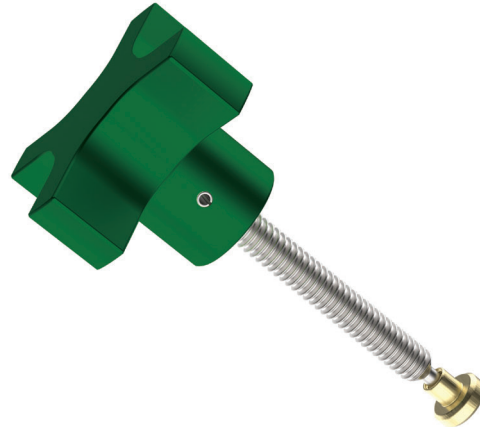

Extruded Hand Knob with Swivel Feet

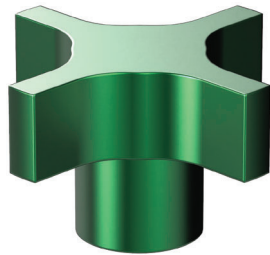

Extruded Hand Knob



Low Profile Pivoting Edge Clamp

www.carrlane.com/product/new-products

PRODUCTS

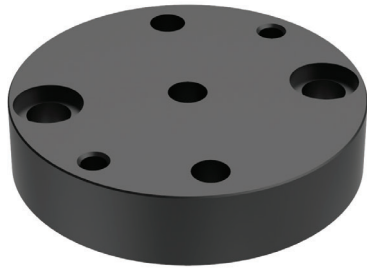

**Reversible
Construction Ball
Pad**



**Modular Hinged
Bushing Plates**



**Headless
Carr Lock® Clamp**



**Forged
T Bolts**



**Through Hole
Screw Rest Button**

CarrLane
MANUFACTURING CO.

PICTORIAL INDEX

Alignment Pins

L PINS, T PINS & JIG PINS



L Pins & T Pins
p. 29



Shoulder Pins
p. 30



Jig Pins
p. 31



Locking L Pins & T Pins
p. 32-33



Captive Jig Pins
p. 34

CLAMPING PINS



Clamping Pins
p. 35



Locking Clamping Pins
p. 36



Captive Locating
Screws
p. 37



Captive Locating
Screws with Hand Knob
p. 38-40



Locking Pin
Bushings
p. 41

SLOTTED LOCATOR BUSHINGS



Press Fit
p. 42-43



Headed Press Fit
p. 44



Knurled
p. 43



Template Type
p. 45

BALL LOCK PINS



Technical
Information
p. 46-47



Ball Lock Pins
p. 48-49



Marine
Ball Lock Pins
p. 50-51



Heavy-Duty
Ball Lock Pins
p. 52-53



Adjustable
Ball Lock Pins
p. 54-55



Double-Acting
Ball Lock Pins
p. 56-57



Lifting Pins
p. 58-59



Ball Lock
Receiver Caps
p. 60

DETENT PINS



Detent Pins
p. 61



Marine Detent Pins
p. 62



Economy Detent Pins
p. 62



Threaded Detent Pins
p. 63

EXPANDING PINS



Cam Handle
p. 64



Hex Head
p. 65

CABLE



Cable Assemblies
p. 66-68



Cable
p. 69



Ferrules
p. 69



Terminals
p. 70



Cable Rings
p. 70



Cable Tabs
p. 70



Crimping Tools
p. 71



Nylon Lanyards
p. 72



Ball Lock
Coupling Rings
p. 72



ALSO SEE:
Carr Lock® System (Jig
and Fixture Bases)
p. 355



ALSO SEE:
Hand-Retractable
Plungers
(Spring-Loaded
Devices)
p. 176



ALSO SEE:
Index Plungers
(Spring-Loaded
Devices)
p. 185

Hoist Rings



Technical Information
p. 73-92



Swivel Hoist Rings
p. 76-83



Side-Pull Hoist Rings
p. 84-87



Pivoting Hoist Rings
p. 88



Lifting Eyes
p. 89



Hoist Eye 360°
p. 90



Hoist Ring Accessories
p. 91



**ALSO SEE:
Lifting Pins (Alignment Pins)**
p. 58-59

Handles, Knobs, and Screw Clamps



Technical Information
p. 93-95

FLUTED KNOBS



Palm-Grip Hand Knobs (Aluminum)
p. 96



Fluted Knobs (Phenolic)
p. 97



Fluted Knobs (Thermoplastic)
p. 98



Star Knobs (Thermoplastic)
p. 99



Star Knobs (Cushion Grip)
p. 99

FOUR-PRONG KNOBS & SCREW CLAMPS



Hand Knobs (Cast Iron)
p. 100



Hand Knobs (Aluminum)
p. 101-103



Hand Knobs (Stainless Steel)
p. 108



Hand Knob Assemblies
p. 104-105



Swivel-Washer Hand Knob Assemblies
p. 106



Knob Shoe Assemblies
p. 107



Bar-Lok Quick-Acting Screw Clamps
p. 114-115



Quick-Acting Knobs
p. 111



Four-Prong Knobs (Phenolic)
p. 109



Four-Prong Knobs (Thermoplastic)
p. 110



Three-Prong Knobs
p. 112

T-HANDLE KNOBS



T-Handle Knobs
p. 113



**ALSO SEE:
Clamping Pins (Alignment Pins)**
p. 29-36

BAR-HANDLE KNOBS & SCREW CLAMPS



Bar-Handle Screw Clamps
p. 115



Bar-Handle Nuts
p. 116



Bar-Lok Quick-Acting Screw Clamps
p. 117



Bar Knobs
p. 111

(continued)

KNURLED KNOBS & SCREW CLAMPS



Knurled-Head Screws
p. 120



Swivel Head Screws
p. 123



Knurled Knobs
p. 126



Adjustable-Torque Thumb Screws
p. 127



Quick-Acting Knurled Knobs
p. 128



Adjustable-Torque Knobs
p. 128



Knurled Knobs (Plastic)
p. 129



ALSO SEE: Knurled Nuts
p. 310

SOCKET SCREW CLAMPS



Swivel Screw Clamps
p. 124



Ball-End Thrust Screws
p. 125



ALSO SEE: Jig Feet Leveling (Supports, Rests, & Feet)
p. 203



ALSO SEE: Gripper Swivel Contact Bolts (Supports, Rests, & Feet)
p. 211-215



ALSO SEE: Gripper Swivel Screws (Supports, Rests, & Feet)
p. 216



Feet For Swivel Screws
p. 122

LATCH SCREWS



Quarter-Turn Screws
p. 114



Half-Turn Screws
p. 114

HAND WHEELS



Hand-Wheel Modifications
p. 130



Cast Iron
p. 131



Aluminum
p. 133



Stainless Steel
p. 134



Thermoplastic
p. 135-136



Solid Handles
p. 138



Revolving Handles
p. 139-141

LEVER HANDLES & CRANK HANDLES



Lever Handles & Lever Bars
p. 142-143



Crank Handles
p. 144



Speed Ball Handles
p. 144



Balanced Crank Handles
p. 145

ADJUSTABLE HANDLES



Steel Body & Plastic Handle
p. 146-147



Stainless Body & Plastic Handle
p. 148



Adjustable Lever Handles
p. 149-150

KNOB HANDLES



Ball Knobs
p. 151-153



Oval Tapered Knobs
p. 154



Tapered Knobs
p. 155



Palm-Grip Handles
p. 155



Knob Handles
p. 156



Tapered Knobs & Handles
p. 157



Pull Knobs
p. 158



T Handles
p. 158



Pull Handles
p. 159-160

Spring-Loaded Devices

SPRING PLUNGERS



Spring Plungers
p. 164-165



Short Spring Plungers
p. 166



Short Spring Plungers with Extended Travel
p. 167



Press-Fit Spring Plungers
p. 168

BALL PLUNGERS



Technical Information
p. 169-170



Ball Plungers
p. 172-173



Press-Fit Ball Plungers
p. 174



Self-Retaining Ball Plungers
p. 175



Ball Detents
p. 171



Plunger Wrenches
p. 171

HAND-RETRACTABLE PLUNGERS



Knurled Head
p. 176



Threaded Stud for Knob Handle
p. 177



Pull Ring (Locking Type)
p. 178



Pull Ring (Non-Locking Type)
p. 179

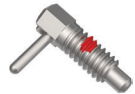

L Handle (Short Stroke)
p. 180



L Handle (Long Stroke)
p. 181



Knob Handle
p. 182



Knob Handle with Mounting Plate
p. 183



Pull Ring (Extended-Locking Type)
p. 184

INDEX PLUNGERS



Tapered Index Plungers
p. 185-187



Straight Index Plungers
p. 188-190

SPRING STOP BUTTONS



Spherical Radius
p. 191



Flat Face with Tang
p. 192



Flat Face
p. 193



Heavy Duty
p. 194

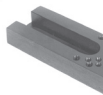

**ALSO SEE:
Spring-Stop Button Adaptors (Modular Fixturing)**
p. 421

SPRING LOCATING PINS



Steel Pin (Coil Spring)
p. 195



Stainless Pin (Polyurethane Spring)
p. 196



Delrin® Pin (Polyurethane Spring)
p. 197



Tapped Receptacle
p. 198



Eccentric Liners
p. 198



**ALSO SEE:
Adjustable-Torque Thumb Screws (Handles, Knobs, & Screw Clamps)**
p. 127



**ALSO SEE:
Adjustable-Torque Knobs (Handles, Knobs, & Screw Clamps)**
p. 128



**ALSO SEE:
Torque Screw Jacks (Supports, Rests, & Feet)**
p. 229

Supports, Rests, and Feet

LEVELING FEET



Leveling Feet
p. 202



Stud Leveling Feet
p. 203



Jig Leveling Feet
p. 201



Jig Feet Leveling Assemblies
p. 201

SWIVEL PADS



Swivel Pads
p. 205



Swivel Nuts
p. 205



Swivel Pad Feet
p. 204

GRIPPERS



Round Grippers
p. 206-208



Square Grippers
p.208-209



Edge Grippers
p. 210



Gripper Contact Bolts
p. 211



Gripper Swivel Contact Bolts
p. 212-213



Gripper Swivel Pads
p. 214-215



Gripper Swivel Screws
p. 216



Round Carbide Pads
p. 216

REST BUTTONS & PADS



Rest Buttons
p. 217-219



Carbide-Tipped Rest Buttons
p. 220



Air Rest Buttons
p. 221-222



Spherical-Radius Locator Buttons
p. 220



Jig Rest Buttons
p. 223



Screw Rest Pads
p. 224



Screw Rest Buttons
p. 224



Swivel Contact Bolts
p. 225



Jig Leg Plates
p. 226



Heavy-Duty Rest Pads
p. 226



Height Shims
p. 227



Eccentric Leveling Lugs
p. 227



Manual Work Supports
p. 228

SCREW JACKS



Knurled Screw Jacks
p. 229



Torque Screw Jacks
p. 229



Adjustable Locating Buttons
p. 229



Heavy-Duty Screw Jacks
p. 230



Through-Hole Leveling Jacks
p. 232



VBlocks
p. 233

Locators

LOCATING PINS



Round & Diamond Locating Pins
p. 236-237



Round & Diamond Locating Pins
p. 238-241



Round & Diamond Locating Pins, DIN 6321
p. 242-243



Floating Locating Pins
p. 244



Bullet-Nose Round & Diamond Pins
p. 245



Bullet-Nose Dowels
p. 246



Cone Locator Pins
p. 246

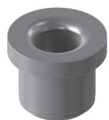

ON-SIZE® Bushings
p. 247

CONSTRUCTION BALLS



Construction Balls (Shoulder Type)
p. 248-249



Construction Balls (Adjustable Type)
p. 250



Construction-Ball Pads
p. 251



Construction-Ball Covers
p. 250

FIXTURE KEYS

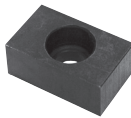

Fixture Keys
p. 254

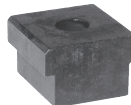

Step Fixture Keys
p. 254



Sure-Lock™ Fixture Keys
p. 255



Locating Keys
p. 256



Pallet Fixture Keys
p. 257

(continued)



Reamed-Hole Fixture Keys
p. 255



Mill Fixture Keys
p. 257



ALSO SEE: Carr Lock® System (Jig and Fixture Bases)
p. 355



ALSO SEE: Fixture Locating Pins (Modular Fixturing)
p. 402

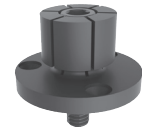

ALSO SEE: ID Clamps (Clamps & Accessories)
p. 258-279

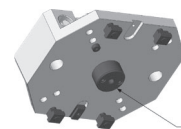

ALSO SEE: Center Locating Keys For Rotary Tables
p. 382



ALSO SEE: Rest Buttons & Pads
p. 217-223



ALSO SEE: CL5® Quick-Change 5-Axis Workholding
p. 371

Clamps and Accessories

CLAMP STRAPS



Forged Adjustable Clamps
p. 261



Slotted-Heel Clamp Straps
p. 262-265



Tapped-Heel Clamp Straps
p. 268-271



Double-End Clamp Straps
p. 276



Step Blocks & Clamps
p. 278-279



Forged U Clamps
p. 277



Aluminum Adjustable Clamps
p. 277



**ALSO SEE:
High-Rise Clamps
(Modular Fixturing)**
p. 429

EDGE CLAMPS

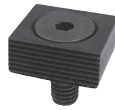

Tiny Vise® Edge Clamps
p. 281-286



Serrated Adjustable Edge Clamps
p. 291

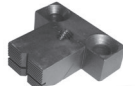

Serrated Fixed Edge Clamps
p. 292



Cam Edge Clamps
p. 290



Pivoting Edge Clamps
p. 293-295



**ALSO SEE:
Pivoting Edge Clamps
(Modular Fixturing)**
p. 402

SWING CLAMPS



Hook Clamps
p. 297-300



One-Touch Quick Acting Swing Clamps
p. 301-303



Floating Clamps
p. 305



Swing Clamp Assemblies
p. 306-307



Up-Thrust Clamps
p. 304



**ALSO SEE:
Hydraulic & Air-Powered Swing Clamps
(ROEMHELD Power Workholding)**
p. 604

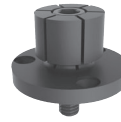

ID Clamps
p.308-309

NUTS



Acorn Nuts
p. 310

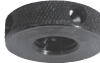

Knurled Nuts
p. 310



Knurled Check Nuts
p. 310



Hex Nuts
p. 311



Jam Nuts
p. 311



Flange Nuts
p. 312



Coupling Nuts
p. 312



Spherical Nuts & Washers
p. 313



**ALSO SEE:
Bar-Handle Nuts
(Handles, Knobs,
& Screw Clamps)**
p. 116



**ALSO SEE:
Bar Knobs (Handles,
Knobs, and Screw Clamps)**
p. 111

WASHERS



Spherical Washers
p. 314



Flat Washers
p. 315



Knurled-Face Washers
p. 315



C Washers
p. 316



Swing C Washers
p. 316



**ALSO SEE:
Flanged Washers
(Toggle Clamps)**
p. 512

STUDS, BOLTS, & T NUTS



Shoulder Screws
p. 323



Studs
p. 317-318



T Nuts
p. 319

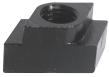

Rotary T Nuts
p. 321



Forged T-Bolts
p. 322



Eye Bolts
p. 325



Swing Bolts
p. 324

CAMS



Cam Handles
p. 326



**ALSO SEE:
Clamp-Strap
Assemblies with
Cam Handles**
p. 262-271



**ALSO SEE:
Cam Edge Clamps**
p. 290



**ALSO SEE:
Vertical-Handle Cam
Clamps
(Toggle Clamps)**
p. 464

CLAMP RESTS & ACCESSORIES



Clamp Rests
p. 327



Guide Blocks
p. 328



Clamp Springs
p. 328

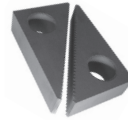

Step Blocks
p. 278



**ALSO SEE:
Stud Leveling Feet
(Supports, Rests,
& Feet)**
p. 203

CLAMPING KITS

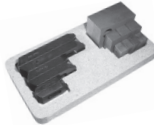

**Step Block
& Clamp Sets**
p. 279



T Nut & Stud Sets
p. 320



**Rotary T Nut
& Stud Sets**
p. 321

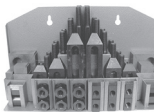

Clamping Kits
p. 329



Deluxe Clamping Kits
p. 330-331

PORTABLE CLAMPS



Swing C Clamps
p. 332



**Drill-Press
Clamps**
p. 333-334



**Also see Forged
Toggle Pliers
(Toggle Clamps)**
p. 497

HAMMERS & HAND TOOLS



T-Slot Cleaners
p. 320



Simplex Hammers
p. 335-337



No-Rebound Hammers
p. 338-340



Soft-Face Punches
p. 340



**ALSO SEE:
Toggle Clamps**
p. 438-512



**ALSO SEE:
Hydraulic
Power Workholding**
p. 602-720



**ALSO SEE:
Air-Powered
Swing Clamps**
p. 613-623



**ALSO SEE:
Precision Vises**
p. 644-664

Threaded Inserts

KEY INSERTS



Technical Information
p. 342-345



Key Inserts (Heavy Duty)
p. 344-345



Key Inserts (Thinwall)
p. 346



Solid Key Inserts
p. 347



Key Insert Installation Tools
p. 347



Key Insert Assortments
p. 348

ADHESIVELY BONDED FASTENERS



Adhesively Bonded Studs
p. 349

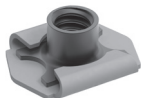

Adhesively Bonded Floating Nut Plates
p. 350

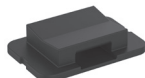

Adhesively Bonded Lanyard Mounts
p. 350

Jig and Fixture Bases

CarrLock[®] SYSTEM



Carr Lock[®] Clamps
p. 354-370



Carr Lock[®] Liner Bushings
p. 356



Carr Lock[®] Receiver Bushings
p. 357

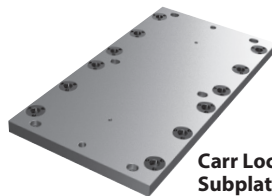

Carr Lock[®] Subplates
p. 360-367

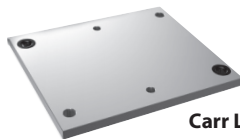

Carr Lock[®] Fixture Plates
p. 359-367

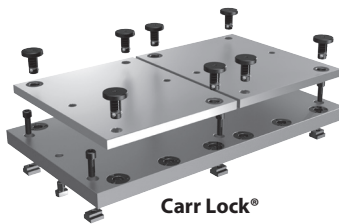

Carr Lock[®] System Kits
p. 358

QUICK-CHANGE 5-AXIS WORKHOLDING



Quintus Zero-Point Quick-Change Risers
p. 373



5-Axis Vises
p. 375-376

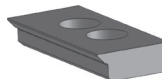

Dovetail Clamping
p. 377

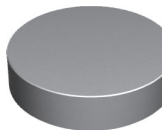

Fixture Plates
p. 379



ALSO SEE: DropZero[®] Modular Zero-Point System
p. 658-661

BLANK TOOLING PLATES

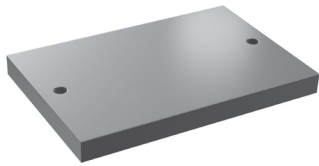

**Rectangular
Tooling Plates**
p. 386

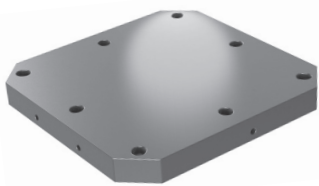

**Square Pallet
Tooling Plates**
p. 387

BLANK TOOLING BLOCKS



**Two-Sided
Tooling Blocks**
p. 388



**Four-Sided
Tooling Blocks**
p. 389

CAST SECTIONS



V
p. 392

HINGED BUSHING PLATES

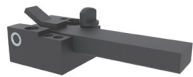

**Hinged Bushing
Plates**
p. 393



Mod Plate
p. 395

ANGLE BRACKETS



Angle Brackets
p. 390

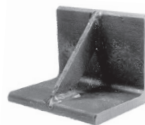

**Gusseted
Angle Brackets**
p. 390

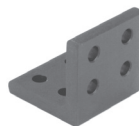

**Angle Brackets
with Locating
Holes**
p. 391

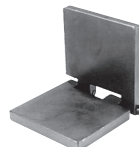

**Adjustable
Angles**
p. 392

TRUNNIONS



**Locking
Trunnions**
p. 396

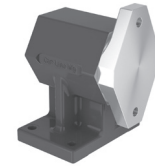

**Revolving
Trunnions**
p. 397

ADJUSTABLE LOCKING HUBS



**Heavy Duty/
Stainless**
p. 399-402

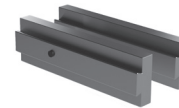

**ALSO SEE:
CARVESMART™
Dovetailed Quick-
Change Vise Jaw
System**
See website

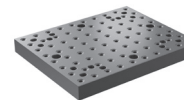

**ALSO SEE:
Modular Tooling
Plates & Blocks
(Modular Fixturing)**
p. 405



**ALSO SEE:
DropZero®
Modular
Zero-Point System**
p. 658-661



**ALSO SEE:
Precision Vises**
p. 644-664



**ALSO SEE:
Assembly & Handling
Technology**
p. 720

Modular Fixturing



Technical Information
p. 407-410

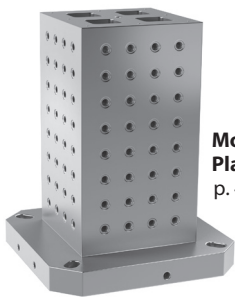

Modular Tooling Plates & Blocks
p. 413-414



Modular Mounting Accessories
p. 415



Modular Supports & Locators
p. 417-418



Modular Clamps
p. 429-430

Toggle Clamps



Technical Information
p. 428-441



Horizontal-Handle Toggle Clamps
p. 443-451



Vertical-Handle Toggle Clamps
p. 451-475



Push/Pull Toggle Clamps (Plunger Type)
p. 476-487



Latch-Action Toggle Clamps
p. 488-495



Toggle Pliers
p. 496-500



Air-Powered Clamps
p. 501-508



Toggle Clamp Accessories
p. 508-512

Stage & Film



Glow Wagon Brakes
p. 514



**ALSO SEE:
Hoist Rings**
p. 73-92



**ALSO SEE:
Lifting Pins**
p. 58-59



**ALSO SEE:
Ball Lock Pins**
p. 46-57



**ALSO SEE:
Threaded Inserts**
p. 348



**ALSO SEE:
Hi-Viz Hammers**
p. 339

Drill Bushings



Technical Information
p. 516-521



Quick-Ship Drill Bushings
p. 522-523



Press-Fit Bushings
p. 524-535



Renewable Bushings
p. 536-542



Liner Bushings
p. 543-548



Bushing Handles
p. 549



Lockscrews and Clamps
p. 550-551



Chip-Breaker Bushings
p. 552-553



Directed-Coolant Bushings
p. 554



Oil-Groove Bushings
p. 556-558



Castable Bushings
p. 559-563



Template Bushings
p. 564-567



Gun-Drill Bushings
p. 568-570



Air-Feed Bushings
p. 571-585

ROEMHELD Power Workholding



Product Features, Design Information, and Safety Precautions
p. 589-601



Swing Clamps
p. 613-623



Extending Clamps
p. 603-606



Threaded Cylinders
p. 637-641

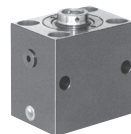

Block Cylinders
p. 629



Work Supports
p. 631 (Index)



Fixture Clamps
p. 662-664



Hydraulic Power Sources
p. 667



Hydraulic Valves
p. 678



Fittings & Accessories
p. 690



Zero-Point Mounting Systems
p. 658



Precision Vises
p. 644-655



Assembly & Handling Technology
p. 720

CarrLane
MANUFACTURING CO.

Follow Us



Carr Lane Manufacturing Co.



Carr Lane Manufacturing Co.



@CarrLane



CarrLaneMfg

ALPHABETICAL INDEX

KEY TO CATALOG SECTIONS

Tooling Components	Tabbed Sections 1-9 (pages 27-401)
Modular Fixturing	Tabbed Section 10 (pages 402-437)
Toggle Clamps	Tabbed Section 11 (pages 438-512)
Stage & Film	Tabbed Section 12 (pages 513-514)
Drill Jig Bushings	Tabbed Section 13 (pages 515-586)
Power Workholding	Tabbed Section 14 (pages 587-720)

A

AA.....	390-392
AB.....	390
ABA.....	390
ABK.....	391
ABLB.....	391
ABP.....	54-55
Accessories, Toggle Clamp.....	508-512
Accumulators.....	700
Acorn Nuts.....	310
Adhesively Bonded Fasteners.....	349-352
Adjustable Angles.....	392
Adjustable Ball Lock Pins.....	54-55
Adjustable Clamps, Aluminum.....	277
Adjustable Clamps, Forged.....	261, 330, 333
Adjustable Clamps, Serrated.....	291-292, 435-436
Adjustable Handles.....	146-148
Adjustable Lever Handles.....	149-150
Adjustable Locking Hubs.....	398-401
Adjustable Locating Buttons.....	229
Adjustable-Torque Knobs.....	128
Adjustable-Torque Thumb Screws.....	127
AED.....	671
AFC.....	671
AFL.....	583
AH.....	146
AHL.....	149-150
AHP.....	147
Air Feed Bushings.....	571-585
Air-Feed Lockscrews.....	583
Air Fittings.....	507
Air Power Units.....	671-673
Air-Powered Swing Clamps.....	628-629
Air-Powered Toggle Clamps.....	502-506
Air Rest Buttons.....	221-222
ALH.....	411-414
Alignment Pins.....	27-65
Aluminum Adjustable Clamps.....	277
Aluminum Hand Knobs.....	96, 101
Aluminum Hand Wheels.....	131
AN.....	310
Anchor Shackles.....	91
Angle Brackets.....	390-392
Angle Brackets, Gussetted.....	390

Angles, Adjustable.....	392
Angles, Cast Section.....	392
ARB.....	222
Assemblies, Cable.....	66-68
Assemblies, Hand Knob.....	94
Assemblies, Hook Clamp.....	296
Assemblies, Jig-Feet Leveling.....	201
Assemblies, Knob Shoe.....	107
ATC.....	465
ATK.....	128
Auto-Locking Plungers.....	186
Automotive Clamps.....	451
Automatic Toggle Clamps.....	451

B

Balanced Crank Handles.....	145
Ball Detents.....	171
Ball-End Thrust Screws.....	125
Ball Knobs.....	151
Ball Lock Coupling Rings.....	72
Ball Lock Pins.....	46-57
Ball Lock Receiver Caps.....	60
Ball Plungers.....	169
Balls, Construction.....	248
Balls, Plastic.....	152-153
Bar Clamps, Toggle.....	496
Bar-Handle Screw Clamps.....	115
Bar-Handle Nuts.....	116
Bar Knobs.....	111
Bar-Lok Quick-Acting Screw Clamps.....	117
BD.....	171
BDP.....	245
BH.....	549
BHQC.....	549
BHN.....	116
BHS.....	116
BK.....	111
Blank Tooling Blocks.....	388
Blank Tooling Plates.....	386
BLCR.....	72
BLH.....	52
BLK.....	117
BLM.....	118
Block Clamps.....	629-630
Block Cylinders.....	629-630

Block Push Clamps.....	629-630
Blocks, Four-Sided Tooling.....	389
Blocks, Guide.....	328
Blocks, Riser.....	382
Blocks, Step.....	278
Blocks, Tooling.....	388
Blocks, Two-Sided Tooling.....	388
Blocks, V.....	422-423
BLP.....	48-49
BLR.....	60
BLT.....	117
BND.....	245
BNV.....	247
Bodies for Swivel Screws.....	121
Bolt Retainers.....	512
Bolts, Angle Bracket Locating.....	391
Bolts, Contact.....	433
Bolts, Eye.....	325
Bolts, Latch (See Swing Bolts).....	324
Bolts, Swing.....	324
BP.....	169
BPD.....	56-57
BPNV.....	247
BR.....	512
BRP.....	245
Brackets, Angle.....	390
BS.....	279
BSH.....	280
BSS.....	118
Bullet-Nose Dowels and Bushings.....	246
Bullet-Nose Pins and Bushings.....	245
Bushing Handles.....	549
Bushings, Air Feed.....	571
Bushings, Bullet-Nose Dowel Pin.....	246
Bushings, Chip Breaker.....	552
Bushings, Circuit Board.....	See website
Bushings, Cone Locator Pin.....	246
Bushings, Diamond Groove.....	559
Bushings, Directed Coolant.....	554
Bushings, Drill Jig.....	515
Bushings, EZ Cast.....	563
Bushings, Gun Drill.....	568
Bushings, Head Liner.....	546
Bushings, Head Press Fit.....	529
Bushings, Liner.....	543
Bushings, Oil Groove.....	556

Bushings, Press Fit.....	524
Bushings, Serrata Groove	561
Bushings, Serrated Press Fit	534-535
Bushings, Slip/Fix Renewable	536-537
Bushings, Slotted Locator	42-45
Bushings, Straight Index Plungers	188
Bushings, Tapered Index Plungers.....	185
Bushings, Template.....	564
Bushings, Un-A-Lok™ Liner	548
Bushings, Un-A-Lok™ Liner, Diamond Knurl	562
Buttons, Adjustable Locating.....	229
Buttons, Jig Rest.....	223
Buttons, Rest	218
Buttons, Screw Rest.....	224
Buttons, Spherical-Radius Locator	220
Buttons, Spring-Stop.....	191
C	
C.....	69
C Clamps.....	332
C Washers.....	316
C Washers, Swing	316
CA.....	296
Cable Assemblies.....	66-68
Cable Rings.....	70
Cables	66-69
Cable Tabs.....	70
CAC.....	297
Cam-Action Hold-Down Clamps	464
Cam Edge Clamps	290
Cam Handles.....	326
Cam-Type Clamp Straps	263
Cap Screws, Hex-Head.....	415
Cap Screws, Socket-Head.....	415
Captive Clamping Pins	36-40
Captive Jig Pins	34
Captive Locating Screws.....	36-40
Carbide-Tipped Rest Buttons.....	220
Carr Lock® Clamps.....	355
Carr Lock® Fixture Plates.....	358
Carr Lock® Liner Bushings	356
Carr Lock® Receiver Bushings	357
Carr Lock® System	355
Carr Lock® System Kits.....	358
Carr Lock® Subplates.....	359
Cast Sections.....	392
CB.....	248
CBP.....	251
CBPK.....	252
CBPR.....	252
CC.....	510
CCPT.....	40
CH.....	326
CHB.....	144-146
Check Nuts, Knurled.....	310
Check Valves, Air.....	507
Check Valves, Hydraulic	702, 704
CHM.....	552
CHP.....	146
Chip Breaker Drill Bushings	552
Circuit Board Drill Bushings.....	See website
CJP.....	34
CJPA.....	34
CK.....	331
CKH.....	331
CKMH.....	329
CL5® 5-Axis Workholding	371
CLK.....	382
Clamp Assemblies, Cam-Type.....	290
Clamp Assemblies, Double-End	428
Clamp Assemblies, Hook.....	296
Clamp Assemblies, Slotted-Heel.....	326
Clamp Assemblies, Swing	296
Clamp Assemblies, Tapered-Nose	271
Clamp Assemblies, Tapped-Heel.....	273
Clamp Assemblies, Wide-Nose	272
Clamp Heels (See Clamp Rests)	327
Clamp Rest Screws.....	327
Clamp Rests.....	327
Clamp Springs	328
Clamp Strap Assemblies	260
Clamp Straps, Cam-Type	263
Clamp Straps, Double-End.....	276
Clamp Straps, Forged Gooseneck	274
Clamp Straps, Forged Straight	274
Clamp Straps, Locator Nose	274
Clamp Straps, Slotted-Heel.....	262
Clamp Straps, Tapered-Nose	271
Clamp Straps, Tapped-Heel.....	268
Clamp Straps, Tapped-Heel Padded	273
Clamp Straps, U-Shaped	277
Clamp Straps, Wide-Nose	272
Clamping Kits.....	329
Clamping Pins.....	35-36
Clamping Pins, Captive	36-40
Clamping Pins, Locking.....	36, 40
Clamping Valves	502
Clamps, Air-Powered	501
Clamps, Aluminum Adjustable.....	277
Clamps, Automotive.....	476
Clamps, Bar	496
Clamps, Block.....	644-645
Clamps, Bushing	566-567
Clamps, C.....	332
Clamps, Cam-Action Hold-Down	464
Clamps, Cam Edge	290
Clamps, Carr Lock®	355
Clamps, Drill-Press	333
Clamps, Edge	457
Clamps, Electric.....	See website
Clamps, Extending.....	603-606
Clamps, Flat.....	551
Clamps, Forged Adjustable	261
Clamps, Forged Strap	274
Clamps, Forged U.....	277
Clamps, High-Rise	429
Clamps, Hinge	609-611
Clamps, Hook.....	296
Clamps, Hold-Down Toggle	334
Clamps, Hydraulic	593
Clamps, ID	308-309
Clamps, Internal.....	308-309
Clamps, Latch Action	488
Clamps, Plain.....	278
Clamps, Power.....	593
Clamps, Push/Pull Toggle.....	471
Clamps, Quick-Acting Screw	117-118
Clamps, Round	550
Clamps, Screw	102-104, 107, 112-122, 148-151
Clamps, Self-Adjusting Plunger	483
Clamps, Serrated Adjustable	453
Clamps, Step	278
Clamps, Strap.....	262-278
Clamps, Power Workholding	593
Clamps, Swing	296
Clamps, Swivel Screw	124, 510
Clamps, Toe	282-295
Clamps, Toggle.....	438-512
Clamps, Tubing	708
Clamps, Up-Thrust	304, 434
CLB.....	245
CLBR.....	357
CLC.....	355
Clevis Pins.....	355
CLFP.....	358
CLFR.....	357
Clips, Hoist Ring	91
CLK.....	382
CLMK.....	369
CLP.....	246
CLPK	355
CLPL.....	356
CLPP	369
CLRS	381
CLS	37-38
CLSK	358
CLSL.....	356
CLSP.....	358
CLTW	396
CLVP	427
CN.....	312
Collet Vises.....	See website
Compact Clamps	613
Concentric Clamps.....	See website
Concentric Vises.....	642
Cone-Cushion Spindles.....	510
Cone Locator Pins and Bushings	246
Construction-Ball Covers.....	250

Construction-Ball Pads.....	251-253
Construction Balls.....	248
Construction Balls, Shoulder.....	248
Contact Bolts.....	433
Control Cylinders.....	See website
Coupling Elements.....	701
Coupling Nuts.....	312
Coupling Rings, Ball Lock.....	72
Couplings, Hydraulic.....	691
Couplings, Rotary.....	691
Couplings, Rotary Valve.....	691
Covers, Construction-Ball.....	250
Covers, Eccentric-Leveling-Lug.....	227
Covers, Optical-Cup Mount.....	See website
CP.....	267
CPKK.....	40
CR.....	327
Crank Handles.....	144-146
Crank Handles, Balanced.....	145
Crimp Gages.....	71
Crimping Tools.....	71
CRS.....	327
CS.....	263-270, 274, 276
CSHK.....	38
CSHKA.....	38
CT.....	71
CTDF.....	71
CTRB.....	220
CW.....	316
Cylinders, Hydraulic.....	639-647
Cylinders, Riser.....	432
Cylinders, Support.....	417-418

D

DC.....	554
DCHL.....	554
DCK.....	331
DCKN.....	331
DCL.....	555
DEA.....	276
Decouplers, Pallet.....	699
Delt-A-Groove (See Diamond Groove Bushings).....	559
Deluxe Clamping Kits.....	330
DEP.....	61
Detent Pins.....	61-63
Detents, Ball.....	171
DF.....	69
DG.....	559
DGM.....	559
Diamond Groove Drill Bushings.....	559
Diamond Locating Pins.....	238
Diamond Pins.....	238-245, 429
Directed Coolant Bushings.....	554
Directional-Control Valves.....	667
DJF.....	223

DLT.....	241
Double-Acting Ball Lock Pins.....	56-57
Double-End Clamp Straps.....	276-277
Double-End Jig Feet.....	218
Dowels, Bullet-Nose.....	246
DPT.....	238
DPX.....	237
DPY.....	237
DPZ.....	237
Drill Bushings, Air Feed.....	571
Drill Bushings, Chip Breaker.....	552
Drill Bushings, Circuit Board.....	See website
Drill Bushings, Diamond Groove.....	559
Drill Bushings, Directed Coolant.....	554
Drill Bushings, EZ Cast.....	563
Drill Bushings, Gun Drill.....	568
Drill Bushings, Head Liner.....	546
Drill Bushings, Head Press Fit.....	529
Drill Bushings, Liner.....	543
Drill Bushings, Oil Groove.....	556
Drill Bushings, Press Fit.....	524
Drill Bushings, Serrata Groove.....	561
Drill Bushings, Serrated Press Fit.....	534-535
Drill Bushings, Slip/Fix Renewable.....	536
Drill Bushings, Template.....	564
Drill Bushings, Un-A-Lok™ Liner.....	548
Drill Bushings, Un-A-Lok™ Liner, Diamond Knurl.....	562
Drill Jig Feet.....	201
Drill-Press Clamps.....	334
DropZero™ Zero Point Mounting.....	658
Duplex Ferrules.....	69
DVJI.....	377

E

EB.....	427
EC.....	622
Eccentric Leveling Lugs.....	227
Eccentric Leveling Lug Covers.....	227
Eccentric Liner.....	198
Economy Detent Pins.....	62
EDP.....	62
Edge Clamps, Cam.....	290
Edge Clamps, Hydraulic.....	593
Edge Clamps, Pivoting.....	293
Edge Clamps, Serrated.....	435
Edge Clamps, TINY VISE®.....	280
Edge Grippers.....	210
EDP.....	62
EG.....	210
EHRP.....	184
Electric Clamps.....	See website
Electric Power Units.....	667-670
ELL.....	227
Expanding Pins.....	64-65
EXPH.....	65

Extending Clamps.....	603
Extension Nuts (see Coupling Nuts).....	312
Extension Supports.....	420
Eye Bolts.....	325
Eye Bolts, Lifting.....	89
EZ.....	563
EZ Cast Drill Bushings.....	563
EZ-Torque™ Swivel Hoist Rings.....	81

F

F.....	69
FAC.....	333
FACA.....	333
FAS.....	91
Fasteners, Adhesively Bonded.....	349
Fasteners, Threaded.....	342
Fast-Lok™ Plate Lifting System.....	See website
FC.....	441
FCP.....	509
FCQA.....	509
Feet, Double-End Jig.....	218
Feet, Drill Jig.....	218
Feet, Jig Leveling.....	199
Feet, Jig-Leveling Assemblies.....	199
Feet, Leveling.....	199
Feet, Stud Leveling.....	199
Ferrules.....	69
FFN.....	312
FGNS.....	274
FHN.....	311
FHSS.....	435
FHW.....	137
Fifth-Axis (see CL5®).....	371
Filter/Regulators.....	706
Filters, High-Pressure Inline.....	706
Finger Handles.....	138
Finger Pins.....	138
Fittings, Air & Hydraulic.....	671
Five-Axis Vises.....	371
Five-Axis Workholding.....	371
Fixture Bases, Blank.....	388
Fixture Clamps.....	662-664
Fixture Hose.....	706
Fixture Keys.....	254
Fixture Keys, Mill.....	257
Fixture Keys, Pallet.....	257
Fixture Keys, Reamed-Hole.....	258
Fixture Keys, Step.....	254
Fixture Keys, Sure-Lock™.....	255
Fixture Machining Kits.....	369
Fixture Plates.....	386-393, 398-399
FJN.....	187
FK.....	254
Flange Nuts.....	312

Flanged Washers	512
Flat Clamps	551
Flat-Cushion Spindles	523
Flat-Head Socket Screws	292
Flat Milled Renewable Drill Bushings.....	541
Flat Washers	315
FLC	305
Floating Clamps	305
Floating Locating Pins	244
Flow-Control Valves	689
FLP	244
Fluid, Hydraulic	706
Fluid Pressure Gauges	704
Fluted Knobs.....	97-98, 136
FM	541
FN	261
Forged Adjustable Clamps	261
Forged Anchor Shackles	91
Forged Gooseneck Clamp Straps	276
Forged Rings	91
Forged Straight Clamp Straps	274
Forged U Clamps	277
Four-Prong Knobs.....	100-108
Four-Sided Tooling Blocks	386
FP.....	138
FR.....	91
FSS	122
FTBB	389
FTPM	414
FUC	277
FW	315

G

GAB.....	390
Gages, Locating.....	416
Gauges, Hydraulic Pressure	671
GB.....	328
GBF	213
GBFN	213
GCB.....	211
GCS	266
GCSA	266
GD.....	568
GDD.....	570
GDE.....	570
GDH.....	570
GDI.....	569
GDL.....	568
Glow Wagon Brakes	514
Gooseneck Clamp Straps.....	266, 274, 276
Gripper Contact Bolts	213
Gripper Swivel Contact Bolts	212
Gripper Swivel Pads.....	214
Gripper Swivel Screws	216
Grippers	212-216
GSB	212

GSF	216
GSP	212
GSPF	215
GSPN	215
GSPS	215
GSS.....	216
Guide Blocks.....	328
Gun Drill Bushings.....	569
Gusseted Angle Brackets	390

H

H	144
Half-Turn Screws.....	114
Hammers, No-Rebound	338
Hammers, No-Mar	348
Hammers, Simplex.....	335
Hand-Knob Assemblies	94
Hand Knobs	96-110
Hand Knobs, Fluted	97-98, 136
Hand Knobs, Four-Prong	100-108
Hand Knobs, Star	99
Hand Knobs, T-Handle.....	113
Hand Knobs, Three-Prong.....	112
Hand Knobs, Palm Grip	96
Hand Pumps.....	674
Hand Retractable Plungers	176
Hand Retractable Plungers, Extended Locking Version	177
Hand Wheels	131
Hand Wheels, Fluted.....	137
Hand Wheel Modifications	130
Handles, Adjustable.....	146
Handles, Cam	326
Handles, Crank.....	144-146
Handles, Finger	138
Handles, Hand Wheel	138-141
Handles, Knob	151-158
Handles, Lever	142
Handles, Palm Grip	156
Handles, Plastic	140-141, 146, 148-149 152-153, 155-160
Handles, Revolving	139-141
Handles, Revolving Ball.....	141
Handles, Speed Ball	144
Handles, Solid	138
Handles, T.....	158
Handles, Tapered.....	157
HBP	393
HC.....	650
HDC	474
HDRP	226
Head Liner Drill Bushings	546
Head Press Fit Drill Bushings.....	529
Headed Slotted Locator Bushings	44
Heavy-Duty Ball Lock Pins.....	52-53
Heavy-Duty Lifting Eyes.....	See website

Heavy-Duty Rest Pads.....	226
Heavy-Duty Screw Jacks	229
Heavy-Duty Spring Stops	194
Heavy-Duty Swivel Hoist Rings	82-83
Height Shims.....	227
Hex Nuts (HN)	311
Hex-Head Cap Screws.....	415
Hex-Head Spindles	508
High-Pressure Inline Filters.....	706
High-Rise Clamps	429
Hinge Clamps	609-611
Hinged Bushing Plates	393
HK.....	101, 105
HKT	102
HL	546
HLD.....	584
HLL.....	584
HM.....	533
HN	311
Hoist Eye 360®.....	90
Hoist Ring Clips	91
Hoist Rings, Pivoting	88
Hoist Rings, Safety	84
Hoist Rings, Shackle.....	See website
Hoist Rings, Heavy-Duty Side Pull	86-87
Hoist Rings, Swivel	76-83
Hollow Plunger Clamps	634
Hook Clamps.....	431
Horizontal-Handle Toggle Clamps.....	442
Horizontal V Blocks	233
Hose, Hydraulic	See website
HP	674
HPA.....	674
HR.....	88
HRC.....	91
HRP	176
HRPK.....	182
HRPM	183
HRPT.....	177
HSLB	44
HTC	441
HTCA	334
HTCD.....	334
HTS.....	114
Hubs, Adjustable Locking	398-401
HVTC.....	441
HWAF	131
HWAR.....	132
HWAS	135
HWSF.....	131
HWSS.....	133
HWTS.....	133
Hydraulic Clamps	593
Hydraulic Cylinders.....	662-664
Hydraulic Fittings & Accessories	706
Hydraulic Fluid	706
Hydraulic Intensifiers	676
Hydraulic Machine Vises	644-667

Hydraulic Swing Clamps.....	602-635
Hydraulic Valves.....	680
Hydraulic Work Supports	637

I

IDC	308
ID Clamps	308-309
Index Plungers	185-187
Inline Filters, High-Pressure	706
Inserts, Key	346-351
Intensifiers, Hydraulic	676

J

Jacks, Screw	229
Jam Nuts	311
Jaws, Vise.....	646
JF	201
JFL	201
Jig Feet, Leveling	201
Jig Feet, Leveling Assemblies	201
Jig Leg Plates.....	226
Jig Pins.....	30
Jig Pins, Captive	34
Jig Pins, Locking	34
Jig Plates	226
Jig Rest Buttons.....	223
JLP	226
JN.....	311
JP	30
JRB.....	223

K

KA	66-67
Key Insert Assortments.....	342
Key Inserts.....	342
Key Rings, Ball Lock	72
Keys, Center Locating	382
Keys, Fixture	254
Keys, Locating.....	256
Keys, Mill Fixture.....	257
Keys, Reamed-Hole Fixture	255
Keys, Step Fixture.....	254
Keys, Sure-Lock™ Fixture	255
KFW	315
KH.....	156
KHS	120
Kits, Carr Lock® System	355
Kits, Clamping.....	329
Kits, T Nut and Stud	321
KK	126
KN.....	310
Knob-Shoe Assemblies.....	107
Knob Handles	156

Knobs, Adjustable Torque.....	127
Knobs, Ball.....	151
Knobs, Bar	111
Knobs, Hand	94
Knobs, Fluted	97
Knobs, Four-Prong.....	109
Knobs, Knurled	126
Knobs, Oval Ball.....	152
Knobs, Oval Tapered	154
Knobs, Palm-Grip Hand	96
Knobs, Plastic	109-110, 126
.....	152-153, 155-159
Knobs, Pull	158
Knobs, Quick-Acting.....	111
Knobs, Quick-Acting Knurled.....	126
Knobs, Star	99
Knobs, Tapered	155-158
Knobs, T-Handle.....	113
Knobs, Three-Prong.....	112
Knurled Check Nuts	310
Knurled-Face Washers	315
Knurled Head Screws	120
Knurled Knobs	126
Knurled Nuts	310
Knurled Screw Jacks	229
Knurled Torque Knobs.....	128
KR	70
KS.....	348
KSA.....	107
KSC.....	342
KSF	342
KSJ.....	229
KSK	344
KSM.....	344
KSMC.....	342
KSMT	344
KSS	347
KSSM	348
KSST.....	348
KST	348
KTK.....	129

L

L Pins.....	29
L	559-560
Lanyards, Cable	66-68
Lanyards, Nylon	72
Latch-Action Toggle Clamps.....	488-495
Latch Bolts (see Swing Bolts).....	324
Latch Plates.....	488
LB.....	229
LCP	36
LE	89
Leg Plates, Jig.....	226
Leveling Assemblies, Jig Feet	201
Leveling Feet.....	201

Leveling Feet, Jig	203
Leveling Feet, Stud	203
Leveling Jacks	232
Leveling Lugs, Eccentric.....	227
Lever Bars.....	143
Lever Handles	142-151
Lever Handle Hubs.....	142
LF	202
LFN.....	202
LFP	58
LFPM	59
LFS.....	204
LHH.....	142
LHRP	180
Life-Ex® Pins	243
Lifting Devices	74-91, 720
Lifting Eyes.....	89
Lifting Pins	58-59
Lifting Units	720
Linear Actuators.....	720
Liner Drill Bushings.....	545
Liner Bushings, Carr Lock®	356
Link Clamps	613-623
LKA.....	68
LLP	32
Load-Rated Cable Assemblies	68
Locating Bolts for Angle Brackets.....	391
Locating Buttons, Adjustable.....	229
Locating Gages.....	416
Locating Keys.....	256
Locating Pins, Diamond	238-243
Locating Pins, Floating	244
Locating Pins, Relieved	230-243
Locating Pins, Round	238-243
Locating Pins, Spring	195
Locating Screws	415
Locating Screws, Captive.....	36-40
Locator Bushings, Slotted	42-45
Locator Buttons, Spherical Radius.....	220
Locator Template Bushings, Slotted	45
Lock Liners	585
Lock Strips.....	583
Locking Clamping Pins.....	36, 40
Locking Hubs, Adjustable	400
Locking Jig Pins.....	34
Locking L Pins	32
Locking Locating Screws.....	37-39
Locking-Pin Bushings	41
Locking T Pins.....	33
Lockscrews.....	550
Lok-A-Pin® (See Locking L Pins, T Pins, and Clamping Pins)	32-35
LP.....	29
LPA.....	492
LPB.....	32-34
LSM.....	583
LSPC.....	441
LTP	33

LVB.....	143
LVTC.....	441

M

Machine Vises	649
Manifold Mounting.....	715-716
Manifolds, Hydraulic.....	716
Manual Work Supports.....	228, 424
Marine Ball Lock Pins.....	50-51
Marine Detent Pins	62
MBP	50-51
MDP.....	62
MFK.....	257
MF	290, 293, 298-300, 408, 425
Mill Fixture Keys.....	257
Modular Fixturing	402-437
Modular Lifting Units.....	720
Multipurpose Extension Supports	420

N

Narrow Riser Blocks	430
NC Machine Vises	644-645
NL	72
NMH	337
No-Bounce Hammers.....	338
No-Mar Hammers.....	337
No-Rebound Hammers	340
NRH.....	338
Nuts, Acorn	310
Nuts, Coupling.....	312
Nuts, Flange.....	312
Nuts, Hex	311
Nuts, Jam.....	311
Nuts, Knurled	310
Nuts, Knurled Check.....	310
Nuts, Spherical.....	313
Nuts, Swivel	205
Nylon Cable Assemblies	66-68
Nylon Cables	66-68
Nylon Lanyards	72

O

OBK.....	152
Oil Groove Bushings.....	556-558
On-Size® Bushings	297
One-Touch Swing Clamps	301-303
Oval Ball Knobs.....	152
Oval Tapered Knobs	154

P

PA.....	488
---------	-----

Pad Covers.....	202
Pads, Clamp Strap	268, 274
Pads, Construction Ball.....	253-254
Pads, Rest	220-227
Pads, Swivel	215
Pallet Decouplers	691-699
Pallet Fixture Keys	257
Pallet Tooling Plates.....	387
Palm-Grip Hand Knobs.....	96
Palm-Grip Handles	156
PB.....	151
PBP.....	174
PBPN.....	174
PBPS	174
PBPSN	174
PC.....	476
PCA	441
PCAV.....	441
PCBE	441
PCBR.....	441
PCBT.....	441
PCCP.....	441
PCCR.....	441
PCEM.....	441
PCHN.....	441
PCQD.....	441
PCQDP.....	441
PCQDS	441
PCSE	441
PCTC	441
PCTE	441
PD.....	698
PDA.....	698
PFK.....	97-98
PFKC	257
PFKR	257
PGH.....	155
PH.....	157
PHK.....	96
PHR.....	160
PHRC	160
PHRP.....	178
PHS	159
PHSC.....	159
Pilot-Operated Check Valves	687
Pins, Adjustable Ball Lock	54-55
Pins, Alignment	27-72
Pins, Ball Lock.....	47-49
Pins, Bullet-Nose	254
Pins, Clamping.....	35-36
Pins, Cone Locator	246
Pins, Detent	61-63
Pins, Diamond	236-237
Pins, Diamond Locating.....	238-242
Pins, Expanding	64-65
Pins, Finger	138
Pins, Floating Locating	244
Pins, Jig	30

Pins, L	29
Pins, Lifting	58-59
Pins, Quick Release	46-65
Pins, Round	236-237
Pins, Round Locating	238-242
Pins, Shoulder	30
Pins, Spring Locating	195-198
Pins, T	29
Pivot Clamps	261
Pivoting Edge Clamps.....	293-295
Pivoting Hoist Rings	88
PK	158
PKO.....	158
PKR.....	158
PL.....	496
Plain Clamps.....	278
Plastic Handles	140-141, 146-149
.....	152-153, 155-160
Plastic Knobs	109-110, 152-153, 155-159
Plates, Jig Leg	226
Plates, Tooling	361-372, 386-387, 425
Pliers, Toggle.....	511-513
Plugs, Protection	369
Plunger Wrenches.....	171
Plungers, Ball	172-173
Plungers, Hand-Retractable.....	176-184
Plungers, Index	185-189
Plungers, Spring	162-167
Pneumatic Toggle Clamps.....	451-526
Power Toggle Clamps.....	451-526
Power Units	667-670
Power Workholding	588-720
PPK.....	109
Preset Torque Wrenches.....	369
Press-Fit Ball Plungers.....	174
Press-Fit Drill Bushings	523-535
Press-Fit Spring Plungers.....	168
Pressure Gauges, Hydraulic	671
Pressure Monitoring.....	671
Pressure-Reducing Valves	686
Pressure-Relief Valves	688
Pressure Switches.....	703
Protection Plugs	369
PSP	168
PSPN.....	168
PSPS.....	168
PSPSN	168
PTC.....	501
PTK.....	154
Pull-Action Toggle Clamps	488-509
Pull Clamps	633
Pull Knobs	158
Pumps, Air.....	671
Pumps, Electric.....	667
Pumps, Hand.....	674
Pumps, Screw.....	675
Push Clamps, Hydraulic.....	676
Push/Pull Toggle Clamps.....	476

PVD	236-237
PVD-Coated Pins	236-237

Q

QAK	111
QFP	380
QKK	128
QRFP	379
QSCH	303
QSCR	301
QSCV	302
QTS	114
Quarter-Turn Screws	114
Quick-Acting Knobs.....	111
Quick-Acting Knurled Knobs.....	128
Quick-Acting Screw Clamps	115, 117
Quick-Acting Swing Clamps, One-Touch	301-303
Quick-Change Fixturing.....	358-394, 396-397
Quick-Change Riser	371
Quick-Change Tooling Plates	361-377
.....	386-393
Quick-Change Workholding.....	358-394, 396-397
Quick Connects/Disconnects, Power	701-702
Quick-Release Pins	46-59, 61-63
Quick-Ship Drill Bushings	522
Quintus Riser.....	378-380, 571, 649, 659

R

RB	219
RBF	381
RBH	141
RC	540
RCM	540
Reamed-Hole Fixture Keys.....	255
Receiver Bushings, Carr Lock®	355
Receiver Caps, Ball Lock.....	60
Rectangular Tooling Plates	386
Relief Valves.....	688
Renewal Road Plates	See website
Rest Buttons	219
Rest Buttons, Carbide-Tipped	220
Rest Buttons, Jig.....	223
Rest Buttons, Screw	224
Rest Pads, Heavy-Duty.....	226
Rests, Clamp	263
Revolving Ball Handles.....	141
Revolving Handles	139-141
Revolving Trunnions	396

RFK	255
RFP	379
RG	206
RGB	208
RGBD	208
RGD.....	212
RGD.....	212
RGF	212
RGFN	212
RGFT	212
RGT	212
RGU.....	212
RHRP.....	179
Rings, Cable	70
Rings, Hoist	75
Riser Blocks	419
Riser Cylinders	432
Riser, Quick Change.....	371
RLT	240
Road Plates	See website
Rocker Clamps.....	See website
Rotary Air Valve Couplings	697
Rotary Couplings.....	690
Rotary T Nuts.....	321
Rotary T Nuts & Stud Sets.....	320
Rotary Valve Couplings	690
Round Carbide Pads	216
Round Clamps	550
Round Grippers.....	206
Round Locating Pins	243
Round Pins.....	236
RP	236
RPC.....	202
RPT.....	238
RTN	321
RTNS	321
RTPB	386
RTPM	411

S

SA	433
SAC	291
Safety Hoist Rings.....	84
SB.....	324
SBC.....	279
SBH	144
SBK.....	153
SBP.....	172
SBPN.....	173
SCA	264
SCB.....	248
SCC.....	332
SCD	616
Scissor-Lok™ Plate Lifting System	See website
Screw Clamps	93

Screw Jacks	229
Screw Pumps.....	675
Screw Rest Pads	224
Screw Rest Buttons	224
Screws, Adjustable Torque Thumb.....	124
Screws, Bodies for Swivel	118
Screws, Clamp Rest.....	327
Screws, Feet for Swivel	119
Screws, Half Turn	111
Screws, Knurled Head.....	117
Screws, Locating.....	415
Screws, Quarter Turn.....	111
Screws, Shoulder	323
Screws, Swivel Head.....	120
Screws, Thumb, Adjustable Torque.....	124
SCW	316
Sections, Cast.....	392
Self-Centering Vises.....	656-657
Self-Retaining Ball Plunger	177
Sequence Valves.....	See website
Serrata Groove Drill Bushings.....	561
Serrated Adjustable Edge Clamps.....	291
Serrated Edge Clamps	291
Serrated Face Washers	316
Serrated Fixed Edge Clamps	293
Serrated Press Fit Drill Bushings	534
SF	536
SFC.....	536
SFK.....	254
SFM.....	539
SFP	340
SG	561
SGB	208
SGC	209
SGT.....	209
SH	138
SHA	264
Shackle Hoist Rings.....	See website
Shackle Pins (see Lifting Pins)	58-59
Shackles	354
SHCS.....	254
Shims, Height.....	423
SHKT	103
SHPA	267
Shoulder Construction Balls.....	248
Shoulder Pins.....	30
Shoulder Screws	323
Shoulder Support Cylinders	418
SHR	76-84
SHRB.....	76-78, 82-84
SHS.....	120
Shutoff Valves.....	688
Side-Pull Hoist Rings, Heavy-Duty.....	86-87
Simplex Hammers.....	335
SIP	188
SIPB.....	188
SK.....	99
SKA.....	66-67

SKR.....	70	SS.....	415	T Pins.....	29
SKS.....	345	SSB.....	421	T-Slot Cleaners.....	320
SKSC.....	345	SSC.....	510	TAPK.....	155
SL.....	511	SSPS.....	165	Tapered Handles.....	157
SLB.....	218	Standard Adjustable Spindles.....	433	Tapered Index Plungers.....	185
SLF.....	331	Star Knobs.....	99	Tapered Knobs.....	155
SLFK.....	255	Stark Quick-Change System.....	384	Tapered-Nose Clamp Straps.....	271
SLFN.....	331	Starter Kits, Carr Lock®.....	355	Taper-Lok Bushings (See Air Feed Bushings).....	571
Slip/Fixed Renewable Bushings.....	536	STC.....	278	Taper-Lok Air-Feed Lockscrews.....	583
SLLB.....	42-44	Step Blocks.....	278	Taper-Lok Liners.....	582
Slotted Bushings.....	42-45	Step Clamps.....	278	Tapped-Heel Clamp Straps.....	268
Slotted-Heel Clamp Straps.....	262	Step Fixture Keys.....	254	Tapped-Heel Padded Clamp Straps.....	273
Slotted-Heel Padded Clamp Straps.....	267	Straight Index Plungers.....	188	TB.....	294-295
Slotted Locator Bushings.....	42-45	Stud Leveling Feet.....	202	TBA.....	625
Slotted Locator Template Bushings.....	45	Studs.....	317-318	TBC.....	701
SLP.....	195	Subplates.....	359	TBCB.....	702
SLPE.....	195	Super Coil™		TDP.....	63
SLPP.....	197	Swivel Hoist Ring.....	See website	Template Bushings.....	564
SLPR.....	198	Support Cylinders.....	418	Tenons (See Fixture Keys).....	254
SLPS.....	196	Supports, Extension.....	402	TERM.....	66
SLPT.....	197	Sure-Lock™ Fixture Keys.....	255	Terminals.....	66
SLTB.....	45	SW.....	314, 364	TH.....	158
SN.....	205	SWA.....	306-307	THA.....	270
SNW.....	263	SWIFTSURE		THPA.....	273
Socket-Head Cap Screws.....	415	Power Workholding.....	644-720	Threaded-Body Push Clamps.....	625
Soft-Face Punches.....	340	Swing Bolts.....	324	Threaded-Body Work	
Solenoid Valves.....	667	Swing C Clamps.....	332	Supports.....	637
Solid Handles.....	138	Swing C Washers.....	316	Threaded Detent Pins.....	63
SP.....	30, 550, 690	Swing-Clamp		Threaded Fasteners.....	342
SPA.....	205	Assemblies.....	306-307	Threaded Inserts, Weld In.....	See website
Spacer Blocks.....	443	Swing Clamps, Air.....	613-623	Threaded Locking-Pin Bushings.....	41
Spacer Shims (see Height Shims).....	227	Swing Clamps, Hydraulic.....	624-628	Threaded Push Clamps.....	624-628
SPC.....	441	Swing Clamps, Manual.....	301	Threaded Template Bushings.....	582-583
Speed-Ball Handles.....	144	Swing Clamps, One-Touch.....	301-303	Three-Prong Knobs.....	109
SPF.....	204	Switches, Pressure.....	701	Thumb Screws.....	127
SPFN.....	204	Swivel Contact Bolts.....	225	Thumb Screws,	
SPG.....	263	Swivel-Foot Spindles.....	510	Adjustable Torque.....	127
SPH.....	335	Swivel-Head Screws.....	123	TINY VISE® Edge Clamps.....	280
Spherical Nuts and Washers.....	313	Swivel Hoist Rings.....	75	TIP.....	185
Spherical-Radius Locator Buttons.....	220	Swivel Nuts.....	205	TK.....	113
SPHR.....	86-87	Swivel Pads.....	205	TL.....	396
Spindles, Toggle Clamp.....	509	Swivel Pad Feet.....	204	TLD.....	584
Spin-N-Lok™		Swivel Pads, Gripper.....	214	TLL.....	584
Swivel Hoist Ring.....	See website	Swivel Screw Bodies.....	121	TLPB.....	40
SPM.....	535	Swivel Screw Clamps.....	124	TN.....	319
SPN.....	165	Swivel Screws, Gripper.....	216	TNH.....	320
Spring-Loaded Spindles.....	511	Swivel-Washer Hand Knob		TNS.....	320
Spring Locating Pins.....	195	Assemblies.....	106	Torque Wrenches.....	369
Spring Plungers.....	162	System Kit, Carr Lock®.....	355	Toggle Clamp Accessories.....	509
Spring-Plunger Wrenches.....	See website			Toggle Clamps.....	438-512
Spring-Stop Buttons.....	191			Toggle Clamps, Self-Adjusting.....	474
Springs, Clamp.....	328			Toggle Pliers.....	496
SPS.....	165			Toggle Push Clamps.....	476
SPW.....	171			Tooling Balls.....	248
Square Grippers.....	208			Tooling Blocks, Four-Sided.....	389
Square Pallet Tooling Plates.....	387			Tooling Blocks, Two-Sided.....	388
SRB.....	224			Tooling Plates, Quick-Change.....	358-394
SRBP.....	175				

T

T Handles.....	158
T Handle Knobs.....	113
T Nut and Stud Sets.....	320
T Nuts.....	319
T Nuts, Rotary.....	321

Tooling Plates, Rectangular	411
Tooling Plates, Round	382
Tooling Plates, Square Pallet	412
Tools, Cable Crimping	71
Tools, Key Insert	344
Tools, Spring Locating Pin	199
Tools, Tubing	706
Torque Screw Jacks	229
Torque Wrenches	396
TP	29
TPC	386
TPK	112
TR	396
Trunnions	396
TS	127
TSA	127
TSCL	320
TSD	129
TSJ	229
TSJN	229
TTB	566
TTBB	388
TTBF	567
TTBT	567
TTR	567
Tubing Clamps	708
Tubing, Hydraulic	708
Tubing Tools	708
TV	282
TVLP	283
TW	512
Two-Sided Tooling Blocks	388

U

U Clamps, Forged	277
U Cast Sections	392
UL	548
ULD	562
ULDM	562
ULM	548
Universal Lifting Rings	See website
Un-A-Lok® Liner Bushings	548
Un-A-Lok® Liner Bushings, Diamond Knurl	See website
Universal Cylinders	631-632
Up-Thrust Clamps	304

V

V	695-704, 709-712, 721
V Blocks	422-423
V Cast Sections	392
VAC	277
VCC	464

Valves, Air	697
Valves, Clamping	680-682
Valves, Hydraulic	680-682
Vertical-Handle Toggle Clamps	453
Vertical V Blocks	423
Vise Jaws	646-647
Vises, Machine	644
Vises, Power	642
Vises, Self-Centering	642
VSA	645
VTC	467-477
VTCA	334
VTCD	334

W

Wagon Brakes	513
Washers, All-in-One Spherical	314
Washers, C	316
Washers, Flanged	512
Washers, Flat	315
Washers, Knurled Face	315
Washers, Serrated Face	315
Washers, Swing C	316
Weld-In Threaded Inserts	See website
Weld Mount® Adhesively Bonded Fasteners	349
Wheels, Hand	131
Wide-Nose Clamp Straps	272
Work Supports, Hydraulic	641
Work Supports, Manual	228
Wrenches, Spring-Plunger	173
WS	652-654

Z

Zero-Point Mounting Systems	658
-----------------------------------	-----



Follow Us



Carr Lane
Manufacturing Co.



Carr Lane
Manufacturing Co.



@CarrLane



CarrLaneMfg

Your Source For Aerospace Tooling Components



CarrLane[®]
MANUFACTURING CO.

Carrlane.com/aerospace-tooling

GENERAL INFORMATION

ORDERING INFORMATION:

Carr Lane Manufacturing products are sold by authorized distributors located throughout North America and the rest of the world. Please see our website or contact us for the name of our qualified stocking distributor nearest you. For technical information, contact our factory engineering staff at 314-647-6200 (1-800-827-2526 for power workholding technical information).

SPECIALS:

Carr Lane Manufacturing will gladly make any special tooling components or company tooling standards to your specifications. Please send a print or sketch with your request. Our wide range of manufacturing capabilities allows us to quickly produce special items for you at economical prices.

DIMENSIONS AND TOLERANCES:

All drawings in this catalog are shown in Third-Angle Projection:

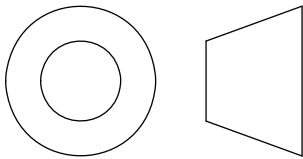

In general, the following maximum tolerances apply to dimensions in this catalog, unless otherwise specified:

- .xxx ±.005
- .xx ±.020
- .x ±.050
- Fractions ± 1/32
- Castings, forgings, molded plastics, and assemblies ± 1/8

FINISH SPECIFICATIONS:

The finishes shown in this catalog are applied according to the following specifications:

- Black Oxide – MIL-C-13924C
- Clear Zinc – ASTM-B633 SC III, Type V SC III
- Yellow Zinc – ASTM-B633 SC III, Type VI SC III
- Cadmium Plate – QQ-P-416, Class 3, Type 1
- Black Anodize – MIL-A-8625, Type II, Class 2

Other finishes are available as specials.

ANSI & TCMAI STANDARDS:

Whenever appropriate, our tooling components meet the standards of the American National Standards Institute (ANSI) and the Tooling Component Manufacturers Association International (TCMAI).

TRADEMARKS:

Numerous trademarks appear throughout this catalog. Delrin® and Zytel® are registered trademarks of E.I. du Pont de Nemours & Co. HAAS® is a registered trademark of Haas Automation Inc. Heavy Duty® Hoist Ring is a registered trademark of ADB.Invar36® is a registered trademark of Carpenter Technology Corporation. WELD MOUNT® is a registered trademark of Royal Adhesives and Sealants, LLC. All other trademarks contained herein are those of Carr Lane Mfg. Co. and its affiliates.

ENGINEERING CHANGES:

All Carr Lane Manufacturing products are continually subject to possible design improvements. We include any engineering changes as soon as possible in our catalogs, tracing templates, CAD tooling libraries, and other literature. However, due to inevitable time lags, dimensions and specifications are subject to change without notice.

GUARANTEE OF QUALITY:

Carr Lane Manufacturing warrants that the products described herein will be free from defects in material and workmanship. If you find any failure to conform to this warranty within 90 days from date of receipt of the product, and give us immediate notification thereof, we will replace the defective product or make suitable repairs. If we are unable to correct such nonconformity by replacing the product or making suitable repairs, whether due to the nature of such nonconformity, your use of the product, or for any other reason, we will refund the purchase price upon receipt of the nonconforming product f.o.b. our plant. No product should be returned to us without a return-authorization number. In no event shall we be liable either directly or by way of contribution or indemnity, for direct, special, incidental or consequential damages such as, but not limited to, property damage, loss of profit, or damages based on loss of use of the product, whether the claim for any such damages be based on warranty, express or implied, contract, tort, or otherwise. This warranty does not apply to products that are misapplied, altered, or abused. The foregoing is our sole warranty with respect to the product. We make no other warranties, express or implied, including implied warranties of merchantability and fitness for a particular purpose.

SAFETY PRECAUTIONS:

Machine tools pose many potential hazards. Observe all appropriate safety precautions, including those specifically listed in this catalog.

ALIGNMENT PINS

1



**L Pins, T Pins, and
Jig Pins**



Clamping Pins



**Slotted Locator
Bushings**



Ball Lock Pins



Detent Pins



Expanding Pins



Cable

Also see:



Hand-Retractable Plungers
p. 176

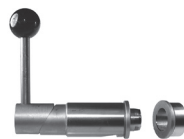

Index Plungers
p. 185



Carr Lock® System
p. 355

L PINS, T PINS, JIG PINS AND CLAMPING PINS

1

L PINS, T PINS, AND JIG PINS



Standard Type

These L Pins, T Pins, Shoulder Pins, and Jig Pins are removable locating pins, precision ground for accurately aligning holes. Available in pin diameters from 1/8 to 3/4", including some number and letter sizes (4 to 20mm in metric), most in a choice of several pin lengths.

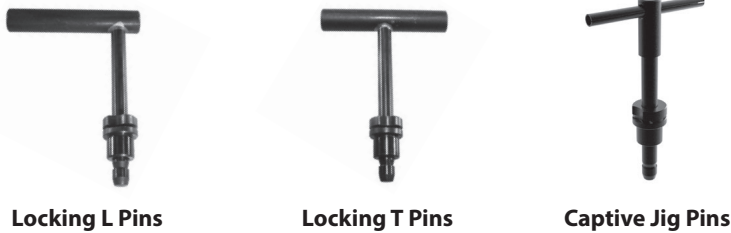

Captive Type

Similar to standard jig pins, except that the pin body is positively retained in a locking bushing. In fully retracted position, the bushing's spring clip snaps into the pin's groove. This holds the pin fully retracted by spring force and positively prevents removal. Spring pressure also holds the pin in intermediate extended positions, an advantage especially if the fixture is turned upside down. Available in pin diameters from 3/16 to 1/2" (6 to 12mm in metric), most in a choice of several pin lengths. Choice of standard or long bushing in most sizes, for installation in thinner or thicker plates.

CLAMPING PINS



Standard Type

Clamping Pins are threaded alignment pins that can be used for locating and clamping, or clamping only, depending on extended screw length. Available in thread sizes from #10-32 to 1/2-13 (M6 to M12 in metric).

Captive Type

Captive clamping pins and locating screws can be used for locating and clamping, or for clamping only, by selecting the appropriate screw length. The locating screw's precision-ground body is positively retained in a locking bushing. In fully retracted position, the bushing's springclip snaps into the body's radial groove. This holds the screw fully retracted by spring force and positively prevents removal. Spring pressure also holds the screw in intermediate extended positions, an advantage especially if the fixture is turned upside down. Available in thread sizes from 1/4-20 to 1/2-13 (M6 to M12 in metric). Choice of standard or long bushing in most sizes, for installation in thinner or thicker plates.

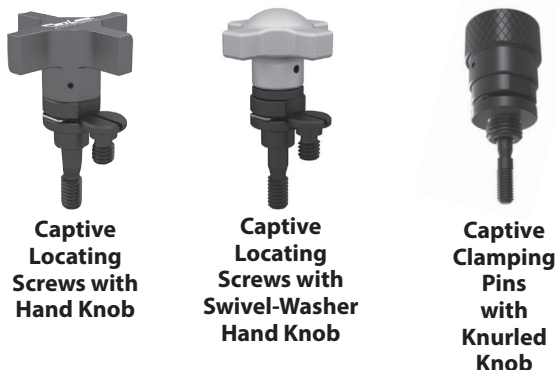

L & T PINS

PIN: 1215 STEEL, CARBURIZED-HARDENED, BLACK OXIDE FINISH
HANDLE: 1215 STEEL, BLACK OXIDE FINISH

1



L Pin

T Pin

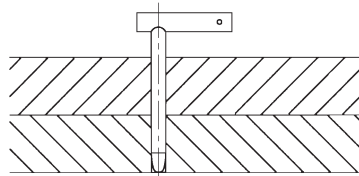

L and T Pins are removable locating pins, precision ground for accurately aligning holes. The pin is inset in the handle and silver soldered to create a sturdy assembly. The handle is drilled for attaching a cable.

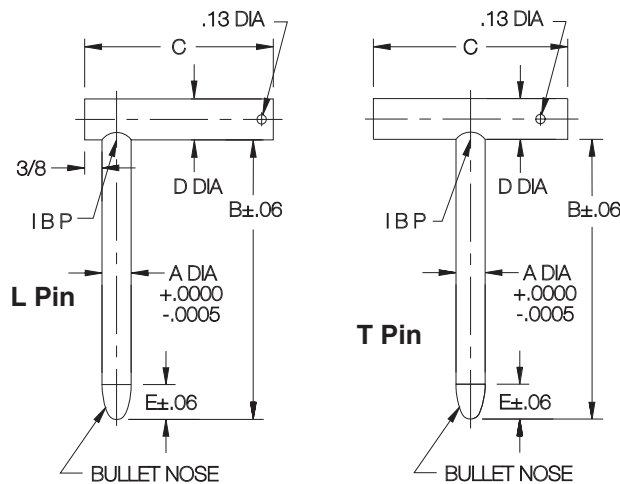

To order L or T Pins with a standard 10-12" cable assembly attached, add "-C" to the part number. (CL-2-C cable with a terminal for #10-32 or M5 attachment screw).
Example: CL-7-LP-C

INCH

L PIN PART NO.	T PIN PART NO.	A DIA		B	C	D DIA	E						
		NOMINAL	ACTUAL										
CL-0-LP	CL-0-TP	1/8	.1250	2-1/2	1-1/2	1/4	1/4						
CL-41-LP	CL-41-TP	#30	.1285	3									
CL-00-LP	CL-00-TP	5/32	.1562	3-1/2	2-1/2	5/16	1/4						
CL-1-LP	CL-1-TP	3/16	.1875	3									
CL-21-LP	CL-21-TP			4									
CL-2-LP	CL-2-TP			6									
CL-3-LP	CL-3-TP	#11	.1910	3									
CL-23-LP	CL-23-TP			4									
CL-4-LP	CL-4-TP			6									
CL-43-LP	CL-43-TP	#10	.1935	3	2-1/2	3/8	3/8						
CL-20-LP	CL-20-TP	#9	.1960	3									
CL-44-LP	CL-44-TP	7/32	.2188	3									
CL-38-LP	CL-38-TP	1/4	.2500	2									
CL-5-LP	CL-5-TP			3									
CL-25-LP	CL-25-TP			4									
CL-6-LP	CL-6-TP	F	.2570	6	2-1/2	3/8	3/8						
CL-17-LP	CL-17-TP			3									
CL-37-LP	CL-37-TP			4									
CL-45-LP	CL-45-TP	9/32	.2812	4				3	7/16	1/2			
CL-39-LP	CL-39-TP	5/16	.3125	2				2-1/2					
CL-7-LP	CL-7-TP			3-1/2				3					
CL-27-LP	CL-27-TP			4									
CL-8-LP	CL-8-TP	3/8	.3750	6	3-1/2	1/2	1/2						
CL-40-LP	CL-40-TP			3				2-1/2					
CL-9-LP	CL-9-TP			4									
CL-29-LP	CL-29-TP			5									
CL-10-LP	CL-10-TP			6									
CL-30-LP	CL-30-TP			7									
CL-11-LP	CL-11-TP	7/16	.4375	4	3-1/2	9/16	5/8						
CL-31-LP	CL-31-TP			5									
CL-12-LP	CL-12-TP			6									
CL-32-LP	CL-32-TP			7									
CL-13-LP	CL-13-TP			4				1/2	.5000	3-1/2	5/8	5/8	
CL-14-LP	CL-14-TP			6									
CL-33-LP	CL-33-TP	7											
CL-34-LP	CL-34-TP	9											
CL-18-LP	CL-18-TP	4	9/16	.5625	6	3-1/2	7/8						3/4
CL-19-LP	CL-19-TP	6											
CL-15-LP	CL-15-TP	6											
CL-35-LP	CL-35-TP	5/8	.6250	8	3-1/2	7/8	3/4						
CL-16-LP	CL-16-TP	6											
CL-36-LP	CL-36-TP	3/4	.7500	8									

METRIC

PART NO.	A DIA (mm)	B (mm)	C (mm)	D DIA (mm)	E (mm)
CLM-4-LP	4	89	63.5	8	5
CLM-5-LP	5	76	63.5	8	5
CLM-50-LP	5	152	63.5	8	5
CLM-6-LP	6	76	63.5	9.5	6.5
CLM-60-LP	6	152	63.5	9.5	6.5
CLM-8-LP	8	89	76	11	11
CLM-80-LP	8	152	76	11	11
CLM-10-LP	10	76	63.5	12.5	11
CLM-100-LP	10	152	89	12.5	11
CLM-12-LP	12	102	89	16	11
CLM-120-LP	12	152	89	16	11
CLM-16-LP	16	152	89	22	17.5
CLM-160-LP	16	203	89	22	17.5
CLM-20-LP	20	152	89	22	17.5
CLM-200-LP	20	203	89	22	17.5

SHOULDER PINS

PIN: 1215 STEEL, CARBURIZED-HARDENED, BLACK OXIDE FINISH
HANDLE: 1215 STEEL, BLACK OXIDE FINISH

1

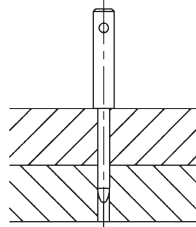

To order Shoulder Pins with a standard 10-12" cable assembly attached, add "-C" to the part number. (CL-2-C cable with a terminal for #10-32 or M5 attachment screw).
Example: CL-7-SP-C

Removable locating pin with a straight handle, precision ground for accurately aligning holes. The handle is drilled for attaching a cable.

INCH

PART NO.	A DIA		B	C	D DIA	E DIA
	NOMINAL	ACTUAL				
CL-7-SP	1/4	.2500	2-1/2	2-5/8	1/2	1/4
CL-10-SP	5/16	.3125			9/16	
CL-14-SP	3/8	.3750	5/8		1/4	
CL-19-SP	1/2	.5000	3/4		5/16	

METRIC

PART NO.	A (mm)	B (mm)	C (mm)	D DIA (mm)	E (mm)
CLM-6-SP	6	65	66.5	12.5	6.5
CLM-8-SP	8	65	66.5	14	6.5
CLM-10-SP	10	100	66.5	16	6.5
CLM-12-SP	12	75	66.5	19	8

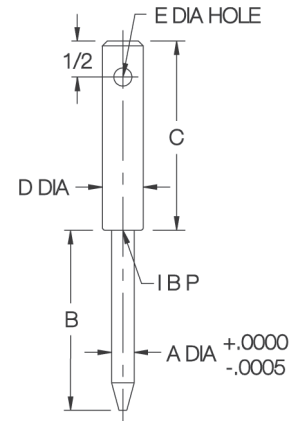

SHOULDER POTTING PINS

1144 STEEL, BLACK OXIDE FINISH

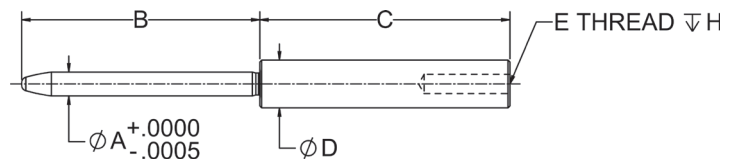

New item!

Shoulder Potting Pins are removable alignment pins used for positioning components to be potted in carbon-fiber composites. The precision-ground pin body and the handle are made from one solid piece of high-carbon steel. The handle end is tapped to allow using a pulling tool. Available in pin diameters from 1/8 to 1/2".

PART NO.	A DIA		B	C	D DIA	E THREAD	H
	NOMINAL	ACTUAL					
CL-225-SPP	1/8	.1250	2.50	2-5/8	1/2	1/4-20	3/4
CL-425-SPP	1/4	.2500	2.50	2-5/8	1/2	1/4-20	3/5
CL-525-SPP	5/16	.3125	2.50	2-5/8	5/8	1/4-20	3/6
CL-640-SPP	3/8	.3750	4.00	2-5/8	5/8	1/4-20	3/7
CL-840-SPP	1/2	.5000	4.00	2-5/8	3/4	1/4-20	3/8

JIG PINS

PIN: 1144 STEEL, HEAT TREATED, BLACK OXIDE FINISH
HANDLE: SPRING STEEL, BLACK OXIDE FINISH

1

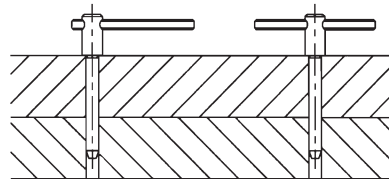

Similar to L and T Pins, but with a shoulder to keep the handle raised. Pins are ground slightly undersize. To convert from an L handle to a T handle, slide the roll-pin handle by tapping it with a hammer.

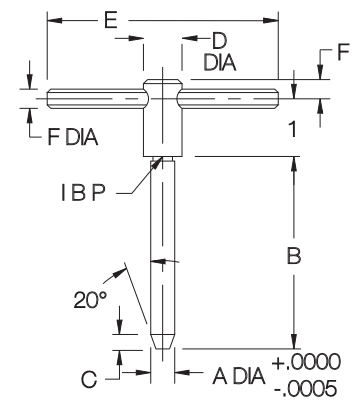

INCH

PART NO.	A DIA		B	C	D DIA	E	F
	NOMINAL	ACTUAL					
CL-10-JP	3/16	.1872	1-7/8	1/8	3/8	2	3/16
CL-20-JP	1/4	.2497	2	5/32			
CL-30-JP	5/16	.3120	2-1/2	3/16	1/2	3	1/4
CL-40-JP	3/8	.3745	3-1/4	1/4			
CL-50-JP	1/2	.4995	4	9/32	9/16	3	1/4

METRIC

PART NO.	A DIA (mm)		B (mm)	C (mm)	D DIA (mm)	E (mm)	F (mm)
	NOMINAL	ACTUAL					
CLM-6-JP	6	5.992	51	3.9	9.5	51	4.8
CLM-8-JP	8	7.988	63.5	4.8	12.5	76	6.5
CLM-10-JP	10	9.987	82.5	6.5	12.5	76	6.5
CLM-12-JP	12	11.986	101.5	7	14	76	6.5

LOCKING L PINS

PIN: 1215 STEEL, CARBURIZED-HARDENED, BLACK OXIDE FINISH
 HANDLE: 1215 STEEL, BLACK OXIDE FINISH
 BUSHING: 8620 STEEL, CASE HARDENED, BLACK OXIDE FINISH

1

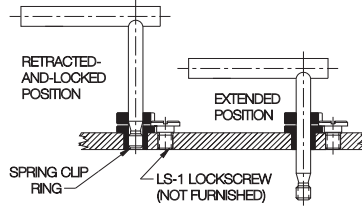

Similar to a standard L Pin, except that the pin body is positively retained in a locking bushing. In fully retracted position, the bushing's spring clip snaps into the pin's radial groove. This holds the pin fully retracted by spring force and positively prevents removal. Spring pressure also holds the pin in intermediate extended positions, an advantage especially if the fixture is turned upside down. Available in pin diameters from 3/16 to 1/2" (6 to 12mm in metric), most in a choice of several pin lengths.

Locking-Pin Bushings are designed to press fit in a standard reamed hole. Secure with the included Lockscrew to positively hold the bushing in place. Shorter or longer bushings are available in most sizes, for thinner or thicker plates.

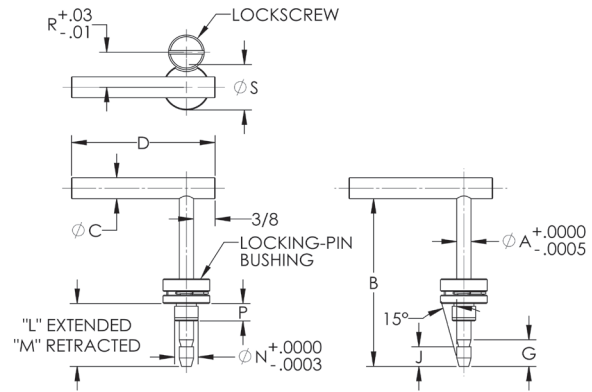

COMPLETE ASSEMBLY (INCH)

PART NO.	A DIA		B PIN LENGTH	P BUSHING LENGTH UNDER HEAD		C DIA	D	G	J	L	M	N DIA		R	S	L PIN (INCLUDED)	BUSHING (INCLUDED)	LOCKSCREW (INCLUDED)										
	NOMINAL	ACTUAL		NOMINAL	ACTUAL																							
CL-1A-LLP-B	3/16	.1865	1-1/2	Standard	.31	5/16	2-1/2	.47	.35	1	.20	13/16	.4078	.62	13/16	CL-1A-LLP	CL-3-LPB	LS-1										
CL-1-LLP-B			3	Standard	.31					2-1/2						CL-1-LLP	CL-3-LPB											
CL-38-LLP-B	1/4	.2490	2	Standard	.31	3/8	2-1/2	.47	.35	1-1/2	.20	13/16	.4078	.62	13/16	CL-38-LLP	CL-4-LPB	LS-1										
CL-38-LLP-B-2				Long	.50					CL-4A-LPB																		
CL-5-LLP-B			3	Standard	.31					2-1/2						CL-5-LLP	CL-4-LPB											
CL-5-LLP-B-2				Long	.50					CL-4A-LPB																		
CL-25-LLP-B	4	.2490	4	Standard	.31	5/8	3	.47	.35	3-1/2	.20	1/2	.5017	.62	13/16	CL-25-LLP	CL-4A-LPB	LS-1										
CL-25-LLP-B-2				Long	.50					CL-4A-LPB																		
CL-39-LLP-B-1	5/16	.3115	3-1/2	Standard	.31					5/8						3	.47		.35	1-1/2	.20	1/2	.5017	.62	13/16	CL-39-LLP	CL-5-LPB	LS-1
CL-39-LLP-B				Medium	.37															CL-5A-LPB								
CL-39-LLP-B-3				Long	.50	CL-5B-LPB																						
CL-7-LLP-B-1	5/16	.3115	3-1/2	Standard	.31	5/8	3	.47	.35	3	.20	1/2	.5017	.62	13/16	CL-7-LLP	CL-5-LPB	LS-1										
CL-7-LLP-B				Medium	.37					CL-5A-LPB																		
CL-7-LLP-B-3				Long	.50					CL-5B-LPB																		
CL-8-LLP-B-1	5/16	.3115	6	Standard	.31	5/8	3	.47	.35	5-1/2	.20	1/2	.5017	.62	13/16	CL-8-LLP	CL-5-LPB	LS-1										
CL-8-LLP-B				Medium	.37					CL-5A-LPB																		
CL-8-LLP-B-3				Long	.50					CL-5B-LPB																		
CL-40A-LLP-B-1	3/8	.3740	2	Standard	.31	5/8	3-1/2	.47	.35	1-1/2	.20	5/8	.6267	.62	13/16	CL-40A-LLP	CL-6-LPB	LS-1										
CL-40A-LLP-B				Long	.50					CL-6A-LPB																		
CL-9-LLP-B-1			4	Standard	.31					3-1/2						CL-9-LLP	CL-6-LPB											
CL-9-LLP-B				Long	.50					CL-6A-LPB																		
CL-10-LLP-B-1	6	.3740	6	Standard	.31	5/8	3-1/2	.47	.35	5-1/2	.20	3/4	.7518	.75	1-1/16	CL-10-LLP	CL-6-LPB	LS-1										
CL-10-LLP-B				Long	.50					CL-6A-LPB																		
CL-13A-LLP-B-1	2	.4990	2	Standard	.50					5/8						3-1/2	.47		.35	1-1/2	.20	3/4	.7518	.75	1-1/16	CL-13A-LLP	CL-8-LPB	LS-1
CL-13A-LLP-B				Long	.75															CL-8A-LPB								
CL-13-LLP-B-1	4	.4990	4	Standard	.50	5/8	3-1/2	.47	.35	3-1/2	.20	3/4	.7518	.75	1-1/16	CL-13-LLP	CL-8-LPB	LS-1										
CL-13-LLP-B				Long	.75					CL-8A-LPB																		
CL-14-LLP-B-1	6	.4990	6	Standard	.50					5/8						3-1/2	.47		.35	5-1/2	.20	3/4	.7518	.75	1-1/16	CL-14-LLP	CL-8-LPB	LS-1
CL-14-LLP-B				Long	.75															CL-8A-LPB								

COMPLETE ASSEMBLY (METRIC)

CLM-6-LLP-B	6mm	.2352	3	Standard	.31	3/8	2-1/2	.47	.35	2-1/2	.20	10mm	.3952	.630	.87	CLM-6-LLP	CLM-6-LPB	LSM-3
CLM-8-LLP-B	8mm	.3140	3	Standard	.39	7/16	3-1/2	.47	.35	2-1/2	.20	13mm	.5135	.630	.87	CLM-8-LLP	CLM-8-LPB	LSM-3
CLM-10-LLP-B	10mm	.3927	3	Standard	.47	1/2	3-1/2	.47	.35	2-1/2	.20	16mm	.6316	.630	.87	CLM-10-LLP	CLM-10-LPB	LSM-3
CLM-12-LLP-B	12mm	.4715	4	Standard	.71	5/8	3-1/2	.47	.35	3-1/2	.20	20mm	.7892	.709	1.02	CLM-12-LLP	CLM-12-LPB	LSM-3

LOCKING T PINS

PIN: 1215 STEEL, CARBURIZED-HARDENED, BLACK OXIDE FINISH
 HANDLE: 1215 STEEL, BLACK OXIDE FINISH
 BUSHING: 8620 STEEL, CASE HARDENED, BLACK OXIDE FINISH

1

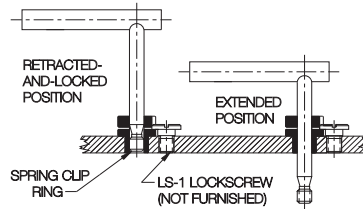

Similar to a standard T Pin, except that the pin body is positively retained in a locking bushing. In fully retracted position, the bushing's spring clip snaps into the pin's radial groove. This holds the pin fully retracted by spring force and positively prevents removal. Spring pressure also holds the pin in intermediate extended positions, an advantage especially if the fixture is turned upside down. Available in pin diameters from 3/16 to 1/2" (6 to 12mm in metric), most in a choice of several pin lengths.

Locking-Pin Bushings are designed to press fit in a standard reamed hole. Secure with the included Lockscrew to positively hold the bushing in place. Shorter or longer bushings are available in most sizes, for thinner or thicker plates.

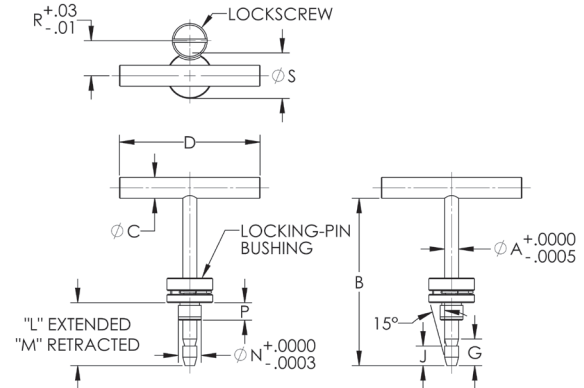

COMPLETE ASSEMBLY (INCH)

PART NO.	A DIA		B PIN LENGTH	P BUSHING LENGTH UNDER HEAD		C DIA	D	G	J	L	M	N DIA		R	S	T PIN (INCLUDED)	BUSHING (INCLUDED)	LOCKSCREW (INCLUDED)										
	NOMINAL	ACTUAL		NOMINAL	ACTUAL																							
CL-1A-LTP-B	3/16	.1865	1-1/2	Standard	.31	5/16	2-1/2	.47	.35	1	.20	13/16	.4078	.62	13/16	CL-1A-LTP	CL-3-LPB	LS-1										
CL-1-LTP-B			3	Standard	.31					2-1/2						CL-1-LTP	CL-3-LPB											
CL-38-LTP-B	1/4	.2490	2	Standard	.31	3/8	2-1/2	.47	.35	1-1/2	.20	13/16	.4078	.62	13/16	CL-38-LTP	CL-4-LPB	LS-1										
CL-38-LTP-B-2				Long	.50					CL-4A-LPB																		
CL-5-LTP-B			3	Standard	.31					2-1/2						CL-5-LTP	CL-4-LPB											
CL-5-LTP-B-2				Long	.50					CL-4A-LPB																		
CL-25-LTP-B	4	.2490	4	Standard	.31	3/8	2-1/2	.47	.35	3-1/2	.20	13/16	.4078	.62	13/16	CL-25-LTP	CL-4-LPB	LS-1										
CL-25-LTP-B-2				Long	.50					CL-4A-LPB																		
CL-39-LTP-B-1	5/16	.3115	2	Standard	.31					5/8						3	.47		.35	1-1/2	.20	1/2	.5017	.62	13/16	CL-39-LTP	CL-5-LPB	LS-1
CL-39-LTP-B				Medium	.37															CL-5A-LPB								
CL-39-LTP-B-3				Long	.50	CL-5B-LPB																						
CL-7-LTP-B-1	5/16	.3115	3-1/2	Standard	.31	5/8	3	.47	.35	3	.20	1/2	.5017	.62	13/16	CL-7-LTP	CL-5-LPB	LS-1										
CL-7-LTP-B				Medium	.37					CL-5A-LPB																		
CL-7-LTP-B-3				Long	.50					CL-5B-LPB																		
CL-8-LTP-B-1	5/16	.3115	6	Standard	.31	5/8	3	.47	.35	5-1/2	.20	1/2	.5017	.62	13/16	CL-8-LTP	CL-5-LPB	LS-1										
CL-8-LTP-B				Medium	.37					CL-5A-LPB																		
CL-8-LTP-B-3				Long	.50					CL-5B-LPB																		
CL-40A-LTP-B-1	3/8	.3740	2	Standard	.31	5/8	3-1/2	.47	.35	1-1/2	.20	5/8	.6267	.62	13/16	CL-40A-LTP	CL-6-LPB	LS-1										
CL-40A-LTP-B				Long	.50					CL-6A-LPB																		
CL-9-LTP-B-1			4	Standard	.31					3-1/2						CL-9-LTP	CL-6-LPB											
CL-9-LTP-B				Long	.50					CL-6A-LPB																		
CL-10-LTP-B-1	6	.3740	6	Standard	.31	5/8	3-1/2	.47	.35	5-1/2	.20	3/4	.7518	.75	1-1/16	CL-10-LTP	CL-6-LPB	LS-1										
CL-10-LTP-B				Long	.50					CL-6A-LPB																		
CL-13A-LTP-B-1	2	.4990	2	Standard	.50					5/8						3-1/2	.47		.35	1-1/2	.20	3/4	.7518	.75	1-1/16	CL-13A-LTP	CL-8-LPB	LS-1
CL-13A-LTP-B				Long	.75															CL-8A-LPB								
CL-13-LTP-B-1	4	.4990	4	Standard	.50	5/8	3-1/2	.47	.35	3-1/2	.20	3/4	.7518	.75	1-1/16	CL-13-LTP	CL-8-LPB	LS-1										
CL-13-LTP-B				Long	.75					CL-8A-LPB																		
CL-14-LTP-B-1	6	.4990	6	Standard	.50	5/8	3-1/2	.47	.35	5-1/2	.20	3/4	.7518	.75	1-1/16	CL-14-LTP	CL-8-LPB	LS-1										
CL-14-LTP-B				Long	.75					CL-8A-LPB																		

COMPLETE ASSEMBLY (METRIC)

CLM-6-LTP-B	6mm	.2352	3	Standard	.31	3/8	2-1/2	.47	.35	2-1/2	.20	10mm	.3952	.630	.87	CLM-6-LTP	CLM-6-LPB	LSM-3
CLM-8-LTP-B	8mm	.3140	3	Standard	.39	7/16	3	.47	.35	2-1/2	.20	13mm	.5135	.630	.87	CLM-8-LTP	CLM-8-LPB	LSM-3
CLM-10-LTP-B	10mm	.3927	3	Standard	.47	1/2	3-1/2	.47	.35	2-1/2	.20	16mm	.6316	.630	.87	CLM-10-LTP	CLM-10-LPB	LSM-3
CLM-12-LTP-B	12mm	.4715	4	Standard	.71	5/8	3-1/2	.47	.35	3-1/2	.20	20mm	.7892	.709	1.02	CLM-12-LTP	CLM-12-LPB	LSM-3

CAPTIVE JIG PINS

PIN: 1144 STEEL, HEAT TREATED, BLACK OXIDE FINISH
 HANDLE: SPRING STEEL, BLACK OXIDE FINISH
 BUSHING: 8620 STEEL, CASE HARDENED, BLACK OXIDE FINISH

1



Similar to a standard Jig Pin, except that the pin body is positively retained in a locking bushing. In fully retracted position, the bushing's spring clip snaps into the pin's groove. This holds the pin fully retracted by spring force and positively prevents removal. Spring pressure also holds the pin in intermediate extended positions, an advantage especially if the fixture is turned upside down. Like standard Jig Pins, Captive Jig pins have an integral shoulder to keep the handle raised. Available in pin diameters from 3/16 to 1/2". Made in USA.

Locking-Pin Bushings are designed to press fit in a standard reamed hole. Secure with the included Lockscrew to positively hold the bushing in place. Shorter or longer bushings are available in most sizes, for thinner or thicker plates.

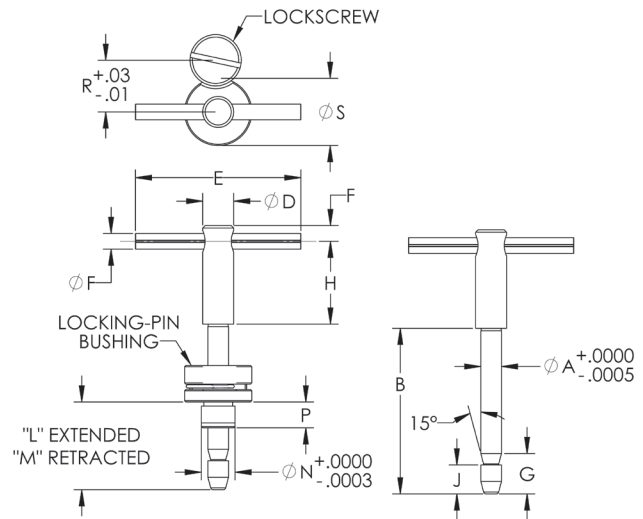
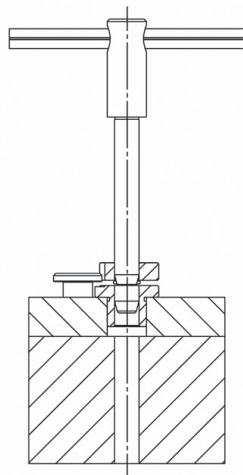
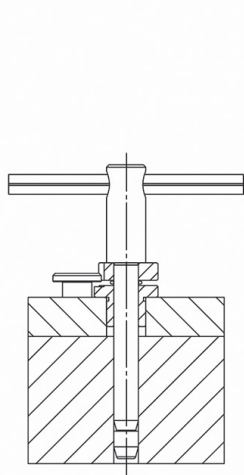

COMPLETE ASSEMBLY (INCH)

PART NO.	A DIA		B PIN LENGTH	P BUSHING LENGTH UNDER HEAD	C	D DIA	E	F	G	H	J	L	M	N DIA		R	S DIA	JIG PIN (INCLUDED)	BUSHING (INCLUDED)	LOCKSCREW (INCLUDED)	
	NOMINAL	ACTUAL												NOMINAL	ACTUAL						
CL-1-CJPA	3/16	.1872	1-7/8	Standard	.31	.35	3/8	2	3/16	.49	1	.35	1.40	.20	13/32	.4078	.62	13/16	CL-1-CJP	CL-3-LPB	LS-1
CL-2-CJPA	1/4	.2497	2	Standard	.31	.35	3/8	2	3/16	.49	1	.35	1.60	.20	13/32	.4078	.62	13/16	CL-2-CJP	CL-4-LPB	LS-1
CL-21-CJPA				Long	.50														CL-4A-LPB		
CL-31-CJPA	5/16	.3120	2-1/2	Standard	.31	.35	1/2	3	1/4	.49	1	.35	2.10	.20	1/2	.5017	.62	13/16	CL-3-CJP	CL-5-LPB	LS-1
CL-3-CJPA				Medium	.37														CL-5A-LPB		
CL-33-CJPA	3/8	.3745	3-1/4	Long	.50	.35	1/2	3	1/4	.49	1	.35	2.80	.20	5/8	.6267	.62	13/16	CL-4-CJP	CL-5B-LPB	LS-1
CL-41-CJPA				Standard	.31														CL-6-LPB		
CL-4-CJPA	1/2	.4995	4	Long	.50	.35	9/16	3	1/4	.49	1	.35	3.60	.20	3/4	.7518	.75	1-1/16	CL-4-CJP	CL-6A-LPB	LS-1
CL-51-CJPA				Standard	.50														CL-8-LPB		
CL-5-CJPA	1/2	.4995	4	Long	.75	.35	9/16	3	1/4	.49	1	.35	3.60	.20	3/4	.7518	.75	1-1/16	CL-5-CJP	CL-8A-LPB	LS-1
CL-5-CJPA				Standard	.50														CL-8-LPB		

CLAMPING PINS

PIN: 1215 STEEL, CARBURIZED-HARDENED, BLACK OXIDE FINISH
 BUSHING: 1215 STEEL, BLACK OXIDE FINISH

1

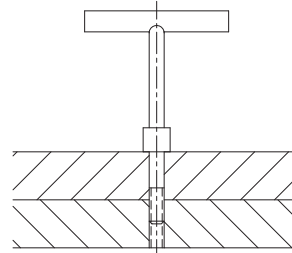

These threaded alignment pins can be used for locating and clamping, or clamping only, depending on extended screw length. The clamping bushing is furnished separate from the pin, and must be welded in place at the proper length to suit the application. Available in thread sizes from #10-32 to 1/2-13 (M6 to M12 in metric).

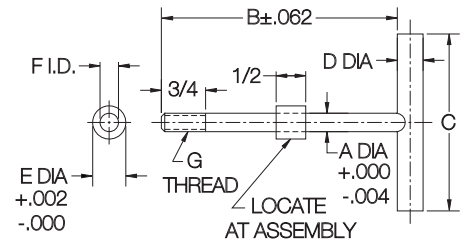

INCH

PART NO.	A DIA		B	C	D DIA	E DIA	F DIA	G
	NOMINAL	ACTUAL						
CL-0-CP	#10	.193	3	1-1/2	1/4	3/8	.203	#10-24
CL-0A-CP								#10-32
CL-1-CP	1/4	.250	4	2-1/2	3/8	1/2	.252	1/4-20
CL-2-CP	5/16	.312		3	7/16	9/16	.315	5/16-18
CL-3-CP	3/8	.375	4-1/2	3-1/2	1/2	5/8	.378	3/8-16
CL-4-CP	1/2	.500	5		5/8	3/4	.503	1/2-13

METRIC

PART NO.	A DIA (mm)	B (mm)	C (mm)	D DIA (mm)	E DIA (mm)	F DIA (mm)	G THREAD	THREAD PITCH (mm)
CLM-6-CP	6	102	63.5	9.5	12.5	6.05	M6	1
CLM-8-CP	8	102	76	11	14.5	8.05	M8	1.25
CLM-10-CP	10	114	89	12.5	16	10.05	M10	1.5
CLM-12-CP	12	127	89	16	19	12.05	M12	1.75

LOCKING CLAMPING PINS

PIN: 1215 STEEL, CARBURIZED-HARDENED, BLACK OXIDE FINISH
 HANDLE: 1215 STEEL, BLACK OXIDE FINISH
 BUSHING: 8620 STEEL, CASE HARDENED, BLACK OXIDE FINISH

1



Locking Clamping Pins are similar to standard Clamping Pins, except that the pin body is positively retained in a locking bushing. In fully retracted position, the bushing's spring clip snaps into the pin's radial groove. This holds the pin fully retracted by spring force and positively prevents removal. Spring pressure also holds the pin in intermediate extended positions, an advantage especially if the fixture is turned upside down.

These threaded alignment pins can be used for locating and clamping, or for clamping only, depending on extended screw length. The upper bushing is furnished separate from the pin, and must be welded in place at the proper length to suit the application. Available in thread sizes from 1/4-20 to 1/2-13 (M6 to M12 in metric).

Locking-Pin Bushings are designed to press fit in a standard reamed hole. Secure with the included Lockscrew to positively hold the bushing in place. Shorter or longer bushings are available in most sizes, for thinner or thicker plates.

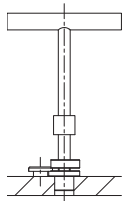

Retracted-and-locked position

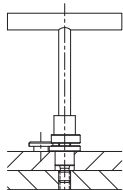

Clamped position

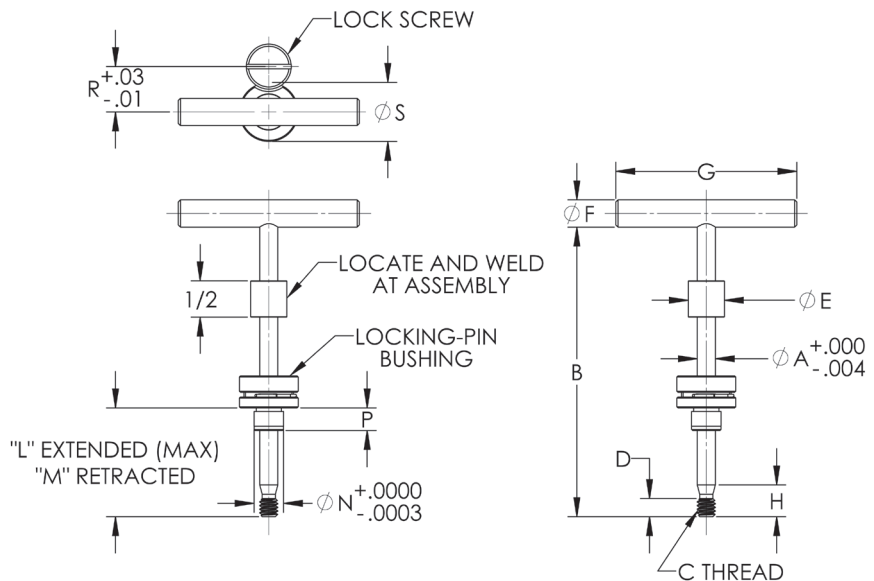

COMPLETE ASSEMBLY (INCH)

PART NO.	A DIA		B PIN LENGTH	P BUSHING LENGTH UNDER HEAD		C THREAD	D	E DIA	F DIA	G	H	L	M	N DIA		R	S	CLAMPING PIN (INCLUDED)	BUSHING (INCLUDED)	LOCKSREW (INCLUDED)
	NOMINAL	ACTUAL		NOMINAL	ACTUAL									NOMINAL	ACTUAL					
CL-1-LCP-B	1/4	.2490	4	Standard	.31	1/4-20	1/4	1/2	3/8	2-1/2	.44	3	.10	13/32	.4078	.62	13/16	CL-1-LCP	CL-4-LPB	LS-1
CL-1-LCP-B-2				Long	.50														CL-4A-LPB	
CL-2-LCP-B-1	5/16	.3115	4	Standard	.31	5/16-18	5/16	9/16	7/16	3	.50	3	.16	1/2	.5017	.62	13/16	CL-2-LCP	CL-5-LPB	LS-1
CL-2-LCP-B-3				Medium	.37														CL-5A-LPB	
CL-2-LCP-B-3				Long	.50														CL-5B-LPB	
CL-3-LCP-B-1	3/8	.3740	4-1/2	Standard	.31	3/8-16	3/8	5/8	1/2	3-1/2	.57	3-1/2	.23	5/8	.6267	.62	13/16	CL-3-LCP	CL-6-LPB	LS-1
CL-3-LCP-B				Long	.50														CL-6A-LPB	
CL-4-LCP-B-1	1/2	.4990	5	Standard	.50	1/2-13	1/2	3/4	5/8	3-1/2	.69	4	.35	3/4	.7518	.75	1-1/16	CL-4-LCP	CL-8-LPB	LS-1
CL-4-LCP-B				Long	.75														CL-8A-LPB	

COMPLETE ASSEMBLY (METRIC)

PART NO.	A DIA (mm)		B PIN LENGTH (mm)	P BUSHING LENGTH UNDER HEAD		C THREAD	THREAD PITCH (mm)	D (mm)	E DIA (mm)	F DIA (mm)	G (mm)	H (mm)	L (mm)	M (mm)	N DIA (mm)		R (mm)	S (mm)	CLAMPING PIN (INCLUDED)	BUSHING (INCLUDED)	LOCKSREW (INCLUDED)
	NOMINAL	ACTUAL		NOMINAL	ACTUAL										NOMINAL	ACTUAL					
CLM-6-LCP-B	6	5.975	102	Standard	8	M6	1	6	12.5	9.5	63.5	11	76	2.3	10	10.038	16	22	CLM-6-LCP	CLM-6-LPB	LSM-3
CLM-8-LCP-B	8	7.975	102	Standard	10	M8	1.25	8	14.5	11	76	14	76	4.1	13	13.043	16	22	CLM-8-LCP	CLM-8-LPB	LSM-3
CLM-10-LCP-B	10	9.975	114	Standard	12	M10	1.5	10	16	12.5	89	17	89	6.1	16	16.043	16	22	CLM-10-LCP	CLM-10-LPB	LSM-3
CLM-12-LCP-B	12	11.975	127	Standard	18	M12	1.75	12	19	16	89	20	102	8.1	20	20.046	18	26	CLM-12-LCP	CLM-12-LPB	LSM-3

CAPTIVE LOCATING SCREWS

SCREW: 1215 STEEL, CARBURIZED-HARDENED, BLACK OXIDE FINISH
 LOCKING-PIN BUSHING: 8620 STEEL, CARBURIZED-HARDENED, BLACK OXIDE FINISH
 RETAINER CLIP: SPRING STEEL



Socket Head

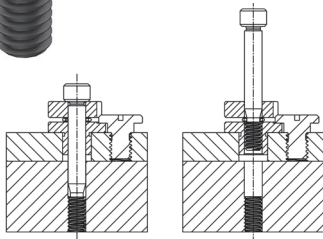

Captive Locating Screws can be used for locating and clamping, or for clamping only, by selecting the appropriate screw length. The locating screw's precision-ground body is positively retained in a locking bushing. In fully retracted position, the bushing's spring clip snaps into the body's radial groove. This holds the screw fully retracted by spring force and positively prevents removal. Spring pressure also holds the screw in intermediate extended positions, an advantage especially if the fixture is turned upside down.

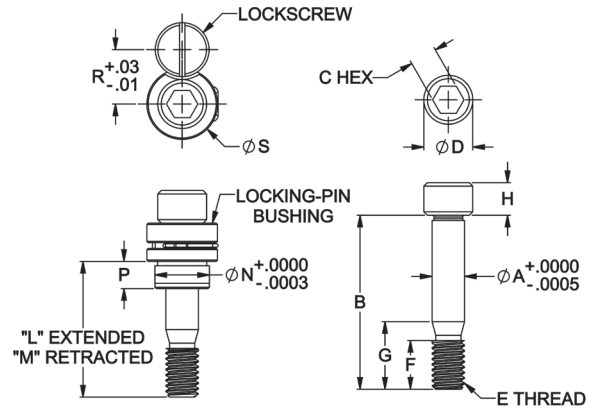

SOCKET HEAD - COMPLETE ASSEMBLY (INCH)

PART NO.	A DIA		B SCREW LENGTH	P BUSHING LENGTH UNDER HEAD	C	D DIA	E THREAD	F	G	H	L	M	N DIA		R	S DIA	LOCATING SCREW (INCLUDED)	BUSHING (INCLUDED)	LOCKSCREW (INCLUDED)
	NOMINAL	ACTUAL											NOMINAL	ACTUAL					
CL-4-CLSA-1.25	1/4	.2490	1-1/4	Standard	3/16	3/8	1/4-20	.40	.59	1/4	.81	.25	13/32	.4078	.62	13/16	CL-4-CLS-1.25	CL-4-LPB	LS-1
CL-42-CLSA-1.25				Long													.50	CL-4A-LPB	
CL-4-CLSA-1.75			Standard	.31							CL-4-LPB								
CL-42-CLSA-1.75	1-3/4		1-3/4	Long							1.31						CL-4-CLS-1.75	CL-4A-LPB	
CL-5-CLSA-1.38				Standard													.31	CL-5-LPB	
CL-52-CLSA-1.38			Medium	.37							CL-5A-LPB								
CL-53-CLSA-1.38	5/16	.3115	1-3/8	Long	1/4	15/32	5/16-18	.47	.65	5/16	.94						CL-5-CLS-1.38	CL-5B-LPB	LS-1
CL-5-CLSA-1.75				Standard													.31	CL-5-LPB	
CL-52-CLSA-1.75			Medium	.37							CL-5A-LPB								
CL-53-CLSA-1.75	1-3/4		1-3/4	Long							1.31						CL-5-CLS-1.75	CL-5B-LPB	
CL-5-CLSA-3.00				Standard													.31	CL-5-LPB	
CL-52-CLSA-3.00			Medium	.37							CL-5A-LPB								
CL-53-CLSA-3.00	3		3	Long							2.56						CL-5-CLS-3.00	CL-5B-LPB	
CL-6-CLSA-1.50				Standard													.31	CL-6-LPB	
CL-62-CLSA-1.50			Long	.50							CL-6A-LPB								
CL-6-CLSA-1.75	3/8	.3740	1-1/2	Standard	5/16	9/16	3/8-16	.56	.75	3/8	1.06		5/8	.6267	.62	13/16	CL-6-CLS-1.50	CL-6-LPB	LS-1
CL-62-CLSA-1.75				Long													.50	CL-6A-LPB	
CL-6-CLSA-2.00			Standard	.31							CL-6-LPB								
CL-62-CLSA-2.00	2		2	Long							1.56						CL-6-CLS-2.00	CL-6A-LPB	
CL-6-CLSA-3.00				Standard													.31	CL-6-LPB	
CL-62-CLSA-3.00	Long	.50	CL-6A-LPB																
CL-8-CLSA-1.50	1/2	.4990	1-1/2	Standard	3/8	3/4	1/2-13	.75	.93	1/2	1.06		3/4	.7518	.75	1-1/16	CL-8-CLS-1.50	CL-8-LPB	LS-1
CL-82-CLSA-1.50				Long													.75	CL-8A-LPB	
CL-8-CLSA-2.00			Standard	.50							CL-8-LPB								
CL-82-CLSA-2.00	2		2	Long							1.56						CL-8-CLS-2.00	CL-8A-LPB	
CL-8-CLSA-3.00				Standard													.50	CL-8-LPB	
CL-82-CLSA-3.00	Long	.75	CL-8A-LPB																

SOCKET HEAD - COMPLETE ASSEMBLY (METRIC)

CLM-6-CLSA-30	6mm	.2352	1.18	Standard	.31	5mm	.39	M6	.39	.56	.24	.71	.15	10mm	.3952	.630	.87	CLM-6-CLS-30	CLM-6-LPB	LSM-3
CLM-8-CLSA-35	8mm	.3140	1.38	Standard	.39	6mm	.51	M8	.47	.66	.31	1.30	.29	13mm	.5135	.630	.87	CLM-8-CLS-35	CLM-8-LPB	LSM-3
CLM-8-CLSA-45			1.77															CLM-8-CLS-45		
CLM-8-CLSA-75			2.95															CLM-8-CLS-75		
CLM-10-CLSA-40	10mm	.3927	1.57	Standard	.47	8mm	.63	M10	.55	.76	.39	1.10	.45	16mm	.6316	.630	.87	CLM-10-CLS-40	CLM-10-LPB	LSM-3
CLM-10-CLSA-50			1.97															CLM-10-CLS-50		
CLM-10-CLSA-75			2.95															CLM-10-CLS-75		
CLM-12-CLSA-50	12mm	.4715	1.97	Standard	.71	10mm	.71	M12	.79	1.02	.47	1.50	.68	20mm	.7892	.709	1.02	CLM-12-CLS-50	CLM-12-LPB	LSM-3
CLM-12-CLSA-60			2.36															CLM-12-CLS-60		
CLM-12-CLSA-75			2.95															CLM-12-CLS-75		

CAPTIVE LOCATING SCREWS

SCREW: 1215 STEEL, CARBURIZED-HARDENED, BLACK OXIDE FINISH
 WASHER: 1010 STEEL, CARBURIZED-HARDENED, BLACK OXIDE FINISH
 LOCKING-PIN BUSHING: 8620 STEEL, CARBURIZED-HARDENED, BLACK OXIDE FINISH. RETAINER CLIP: SPRING STEEL

1

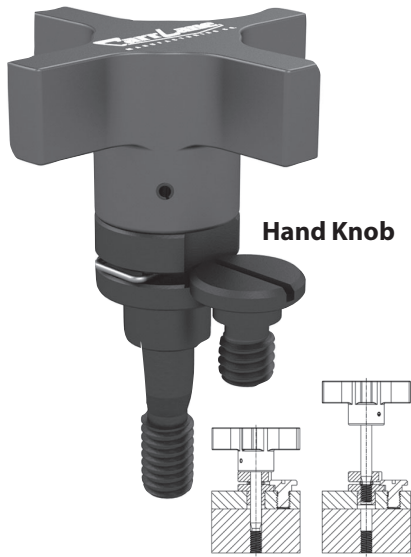

Hand Knob

These Captive Locating Screws have an integral hand knob for tightening by hand. Captive Locating Screws can be used for locating and clamping, or for clamping only, by selecting the appropriate screw length. The locating screw's precision-ground body is positively retained in a locking bushing. In fully retracted position, the bushing's spring clip snaps into the body's radial groove. This holds the screw fully retracted by spring force and positively prevents removal. Spring pressure also holds the screw in intermediate extended positions, an advantage especially if the fixture is turned upside down. **Patent no. 10,393,159**

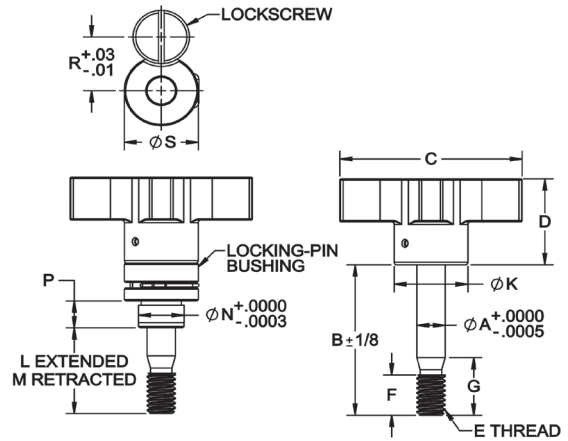

HAND KNOB — COMPLETE ASSEMBLY (INCH)

PART NO.	A DIA		B	P BUSHING LENGTH UNDER HEAD		C	D	E THREAD	F	G	K DIA	L	M	N DIA		R	S DIA	LOCATING SCREW (INCLUDED)	BUSHING (INCLUDED)	LOCKSCREW (INCLUDED)
	NOMINAL	ACTUAL		NOMINAL	ACTUAL									NOMINAL	ACTUAL					
CL-4-CSHKA-1.25	1/4	.2490	1-1/4	Standard	.31	1.8	1.1	1/4-20	.40	.59	3/4	.81	.25	13/32	.4078	.62	13/16	CL-4-CSHK-1.25	CL-4-LPB	LS-1
CL-42-CSHKA-1.25				Long	.50													CL-4A-LPB		
CL-4-CSHKA-1.75			1-3/4	Standard	.31							CL-4-LPB								
CL-42-CSHKA-1.75				Long	.50							CL-4A-LPB								
CL-5-CSHKA-1.38	5/16	.3115	1-3/8	Standard	.31	1.8	1.1	5/16-18	.47	.65	3/4	.94	1/2	.5017	.62	13/16	CL-5-CSHK-1.38	CL-5-LPB	LS-1	
CL-52-CSHKA-1.38				Medium	.37												CL-5A-LPB			
CL-53-CSHKA-1.38			Long	.50	CL-5B-LPB															
CL-5-CSHKA-1.75			1-3/4	Standard	.31							CL-5-LPB								
CL-52-CSHKA-1.75				Medium	.37							CL-5A-LPB								
CL-53-CSHKA-1.75			Long	.50	CL-5B-LPB															
CL-5-CSHKA-3.00			3	Standard	.31							CL-5-LPB								
CL-52-CSHKA-3.00				Medium	.37							CL-5A-LPB								
CL-53-CSHKA-3.00	Long	.50	CL-5B-LPB																	
CL-6-CSHKA-1.50	3/8	.3740	1-1/2	Standard	.31	2.1	1.4	3/8-16	.56	.75	1	1.06	5/8	.6267	.62	13/16	CL-6-CSHK-1.50	CL-6-LPB	LS-1	
CL-62-CSHKA-1.50				Long	.50												CL-6A-LPB			
CL-6-CSHKA-2.00			2	Standard	.31							CL-6-LPB								
CL-62-CSHKA-2.00				Long	.50							CL-6A-LPB								
CL-6-CSHKA-3.00			3	Standard	.31							CL-6-LPB								
CL-62-CSHKA-3.00				Long	.50							CL-6A-LPB								
CL-8-CSHKA-1.50	1/2	.4990	1-1/2	Standard	.50	2.1	1.4	1/2-13	.75	.93	1	1.06	3/4	.7518	.75	1-1/16	CL-8-CSHK-1.50	CL-8-LPB	LS-1	
CL-82-CSHKA-1.50				Long	.75												CL-8A-LPB			
CL-8-CSHKA-2.00			2	Standard	.50							CL-8-LPB								
CL-81-CSHKA-2.00				Long	.75							CL-8A-LPB								
CL-8-CSHKA-3.00			3	Standard	.50							CL-8-LPB								
CL-82-CSHKA-3.00				Long	.75							CL-8A-LPB								

HAND KNOB — COMPLETE ASSEMBLY (METRIC)

CLM-6-CSHKA-30	6mm	.2352	1.18	Standard	.31	1.8	1.1	M6	.39	.56	3/4	.71	.15	10mm	.3952	.630	.87	CLM-6-CSHK-30	CLM-6-LPB	LSM-3
CLM-8-CSHKA-35	8mm	.3140	1.38	Standard	.39	1.8	1.1	M8	.47	.66	3/4	.91	.29	13mm	.5135	.630	.87	CLM-8-CSHK-35	CLM-8-LPB	LSM-3
CLM-8-CSHKA-45			1.77									2.48						CLM-8-CSHK-45		
CLM-8-CSHKA-75			2.95									1.10						CLM-8-CSHK-75		
CLM-10-CSHKA-40			1.57									1.10						CLM-10-CSHK-40		
CLM-10-CSHKA-50	10mm	.3927	1.97	Standard	.47	2.1	1.4	M10	.55	.75	1	1.50	.45	16mm	.6316	.630	.87	CLM-10-CSHK-50	CLM-10-LPB	LSM-3
CLM-10-CSHKA-75			2.95									2.48						CLM-10-CSHK-75		
CLM-12-CSHKA-50			1.97									1.50						CLM-12-CSHK-50		
CLM-12-CSHKA-60	12mm	.4715	2.36	Standard	.71	2.1	1.4	M12	.79	1.02	1	1.89	.68	20mm	.7892	.709	1.02	CLM-12-CSHK-60	CLM-12-LPB	LSM-3
CLM-12-CSHKA-75			2.95									2.48						CLM-12-CSHK-75		

CAPTIVE LOCATING SCREWS

SCREW: 1215 STEEL, CARBURIZED-HARDENED, BLACK OXIDE FINISH
 WASHER: 1010 STEEL, CARBURIZED-HARDENED, BLACK OXIDE FINISH
 LOCKING-PIN BUSHING: 8620 STEEL, CARBURIZED-HARDENED, BLACK OXIDE FINISH.
 RETAINER CLIP: SPRING STEEL

1

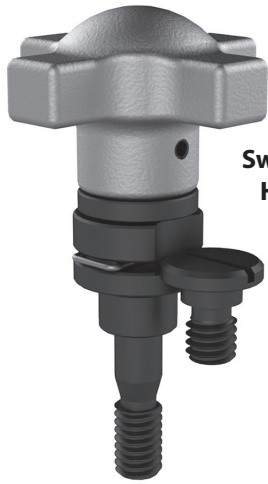

Swivel Washer Hand Knob

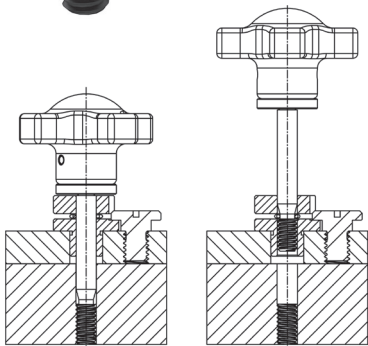

These Captive Locating Screws have an integral hand knob with a rotating swivel washer, which provides smooth clamping with consistent force. Captive Locating Screws can be used for locating and clamping, or for clamping only, by selecting the appropriate screw length. The locating screw's precision-ground body is positively retained in a locking bushing. In fully retracted position, the bushing's spring clip snaps into the body's radial groove. This holds the screw fully retracted by spring force and positively prevents removal. Spring pressure also holds the screw in intermediate extended positions, an advantage especially if the fixture is turned upside down. **Patent no. 10,393,159**

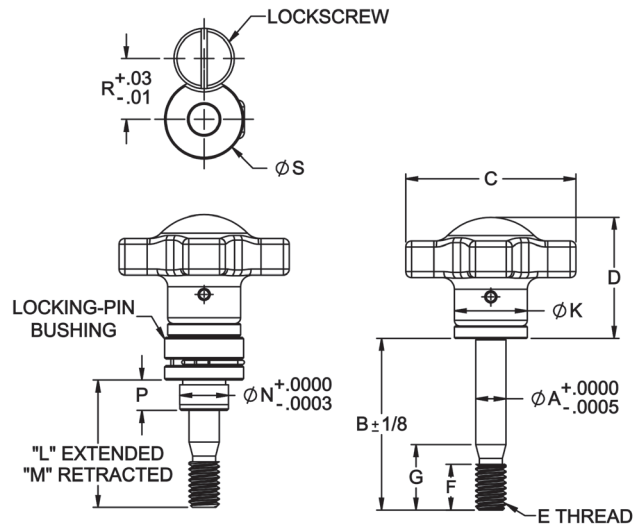

SWIVEL WASHER HAND KNOB — COMPLETE ASSEMBLY (INCH)

PART NO.	A DIA		B	C	D	E THREAD	F	G	K DIA	L	M	N DIA		P	R	S DIA	LOCATING SCREW (INCLUDED)	BUSHING (INCLUDED)	LOCKSCREW (INCLUDED)
	NOMINAL	ACTUAL										NOMINAL	ACTUAL						
CL-4-CLSSHA-1.25	1/4	.2490	1-1/4	1.75	1.33	1/4-20	.40	.59	3/4	.81	.25	13/32	.4078	.31	.62	13/16	CL-4-CLSSH-1.25	CL-4-LPB	LS-1
CL-5-CLSSHA-1.38	5/16	.3115	1-3/8	1.75	1.34	5/16-18	.47	.65	3/4	.94	.32	1/2	.5017	.31	.62	13/16	CL-5-CLSSH-1.38	CL-5-LPB	LS-1
CL-5-CLSSHA-1.75			1-3/4							1.31							CL-5-CLSSH-1.75		
CL-5-CLSSHA-3.00			3							2.56							CL-5-CLSSH-3.00		
CL-6-CLSSHA-1.50	3/8	.3740	1-1/2	2.13	1.47	3/8-16	.56	.75	1	1.06	.41	5/8	.6267	.31	.62	13/16	CL-6-CLSSH-1.50	CL-6-LPB	LS-1
CL-6-CLSSHA-2.00			2							1.56							CL-6-CLSSH-2.00		
CL-6-CLSSHA-3.00			3							2.56							CL-6-CLSSH-3.00		
CL-8-CLSSHA-1.50	1/2	.4990	1-1/2	2.13	1.53	1/2-13	.75	.93	1	1.06	.60	3/4	.7518	.50	.75	1-1/16	CL-8-CLSSH-1.50	CL-8-LPB	LS-1
CL-8-CLSSHA-2.00			2							1.56							CL-8-CLSSH-2.00		
CL-8-CLSSHA-3.00			3							2.56							CL-8-CLSSH-3.00		

SWIVEL WASHER HAND KNOB — COMPLETE ASSEMBLY (METRIC)

PART NO.	A DIA		B	C	D	E THREAD	F	G	K DIA	L	M	N DIA		P	R	S DIA	LOCATING SCREW (INCLUDED)	BUSHING (INCLUDED)	LOCKSCREW (INCLUDED)
	NOMINAL	ACTUAL										NOMINAL	ACTUAL						
CLM-6-CLSSHA-30	6mm	.2352	1.18	1.8	1.33	M6	.39	.56	3/4	.71	.15	10mm	.3952	.31	.630	.87	CLM-6-CLSSH-30	CLM-6-LPB	LSM-3
CLM-8-CLSSHA-35	8mm	.3140	1.38	1.8	1.34	M8	.47	.66	3/4	.91	.29	13mm	.5135	.39	.630	.87	CLM-8-CLSSH-35	CLM-8-LPB	LSM-3
CLM-8-CLSSHA-45			1.77							1.30							CLM-8-CLSSH-45		
CLM-8-CLSSHA-75			2.95							2.48							CLM-8-CLSSH-75		
CLM-10-CLSSHA-40			1.57							1.10							CLM-10-CLSSH-40		
CLM-10-CLSSHA-50	10mm	.3927	1.97	2.1	1.47	M10	.55	.76	1	1.50	.45	16mm	.6316	.47	.630	.87	CLM-10-CLSSH-50	CLM-10-LPB	LSM-3
CLM-10-CLSSHA-75			2.95							2.48							CLM-10-CLSSH-75		
CLM-12-CLSSHA-50			1.97							1.50							CLM-12-CLSSH-50		
CLM-12-CLSSHA-60	12mm	.4715	2.36	2.1	1.53	M12	.79	1.02	1	1.89	.68	20mm	.7892	.71	.709	1.02	CLM-12-CLSSH-60	CLM-12-LPB	LSM-3
CLM-12-CLSSHA-75			2.95							2.48							CLM-12-CLSSH-75		

CAPTIVE CLAMPING PINS

KNOB: 8620 STEEL, CASE HARDENED, BLACK OXIDE FINISH
 PIN BODY: 1215 STEEL, CARBURIZE HARDENED, BLACK OXIDE FINISH

1



Assembly with Knurled Knob

These Captive Clamping Pins have a knurled knob for tightening by hand and a pin body that is positively retained in a locking bushing. In fully retracted position, the bushing's spring clip snaps into the pin's radial groove. This holds the pin fully retracted by spring force. These pins also incorporate a positive thread stop (the .10"-long unthreaded portion with a square shoulder, above the threads) to positively prevent screwing the pin past the spring clip. Spring pressure also holds the pin in intermediate extended positions, an advantage especially if the fixture is turned upside down. Available in fine-thread sizes from #10-32 to 3/8-24.

These clamping pins must be ordered as three separate items: (1) Knurled Knob with roll pin; (2) Pin Body; (3) Locking-Pin Bushing. The Pin Body must be cut to length and pinned by the customer to suit the specific application (3" maximum A dimension). For dimensions and specifications of Locking-Pin Bushings, see opposite page.

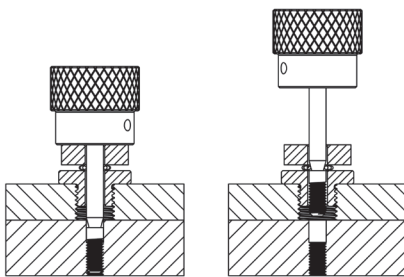
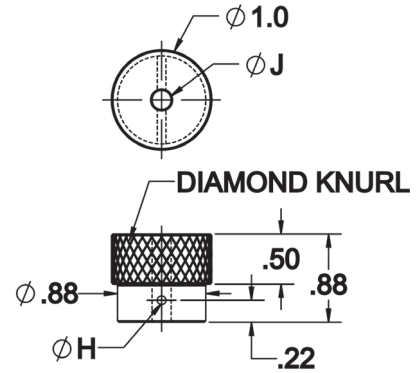

KNURLED KNOB WITH ROLL PIN (INCH)

PART NO.	KNOB DIA	H DIA	J DIA
CL-190-CPKK	1	1/16	.190
CL-250-CPKK		3/32	.250
CL-313-CPKK		3/32	.313
CL-375-CPKK		1/8	.375



Knurled Knob with Roll Pin

Pin Body

Locking-Pin Bushing

ASSEMBLY EXAMPLE

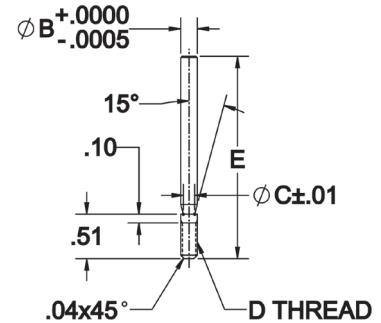
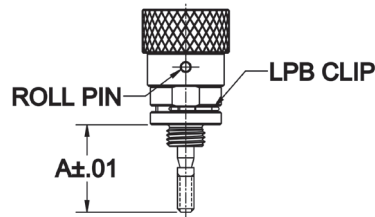

PIN BODY (INCH)

PART NO.	A MAX	B DIA		C DIA	D THREAD	E
		NOMINAL	ACTUAL			
CL-190-CCPT-3.000	3.000	#10	.1890	.13	#10-32	4.32
CL-250-CCPT-3.000		1/4	.2490	.17	1/4-28	
CL-313-CCPT-3.000		5/16	.3115	.21	5/16-24	
CL-375-CCPT-3.000		3/8	.3740	.26	3/8-24	

LOCKING-PIN BUSHINGS (INCH)

PART NO. STANDARD PRESS-FIT BUSHING	PART NO. OVERSIZE PRESS-FIT BUSHING	PART NO. OVERSIZE THREADED BUSHING	FOR PIN BODY DIA
—	—	CL-3-TLPB-OS	#10
CL-4-LPB	CL-4-LPB-OS	CL-4-TLPB-OS	1/4
CL-5-LPB	CL-5-LPB-OS	CL-5-TLPB-OS	5/16
CL-6-LPB	CL-6-LPB-OS	CL-6-TLPB-OS	3/8

LOCKING-PIN BUSHINGS

PRESS FIT: 8620 STEEL, CASE HARDENED, BLACK OXIDE FINISH
 THREADED: 1215 STEEL, CARBURIZE HARDENED, BLACK OXIDE FINISH



Press Fit

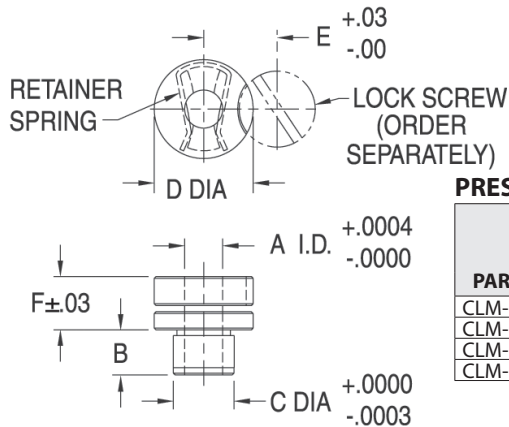

Locking-Pin Bushings are equipped with a retainer spring clip on the inside diameter. These bushings are used with all types of locking/captive pins and locating screws. Available for pin diameters 3/16 to 1/2" (6 to 12mm in metric). Some bushings are available in a choice of lengths, to suit thinner or thicker plates. Several bushing sizes are optionally available with an oversize ID (.040" larger), for applications with multiple pins where additional clearance is desired to prevent binding. Locking-Pin Bushings are designed to press fit in a standard reamed hole. Secure with a Lockscrew to positively hold the bushing in place – order separately as part number LS-1 (inch) or LSM-3 (metric).

PRESS FIT (INCH)

PART NO.	A DIA		B	C DIA		D DIA	E	F	MATCHING P BUSHING FOR BOTTOM PLATE
	NOMINAL	ACTUAL		NOMINAL	ACTUAL				
CL-3-LPB	3/16	.1868	.31	13/32	.4078	13/16	.62	.44	P-26-6-.1865
CL-4-LPB	1/4	.2493	.31						
CL-4A-LPB			.50						
CL-5-LPB			.31						
CL-5A-LPB	5/16	.3118	.37	1/2	.5017				P-32-6-.3115
CL-5B-LPB			.50						
CL-6-LPB	3/8	.3743	.31	5/8	.6267				P-40-8-.3740
CL-6A-LPB			.50						
CL-8-LPB	1/2	.4993	.50	3/4	.7518	1-1/16	.75		P-48-12-.4990
CL-8A-LPB			.75						

PRESS FIT (METRIC)

PART NO.	A DIA (mm)		B LENGTH UNDER HEAD (mm)	C DIA (mm)		D DIA (mm)	E (mm)	F (mm)	LOCKSCREW (ORDER SEPARATELY)	
	NOMINAL	ACTUAL		NOMINAL	ACTUAL					
CLM-6-LPB	6	5.982	Standard	8	10	10.038	22	16	12	LSM-3
CLM-8-LPB	8	7.982	Standard	10	13	13.043	22	16	12	LSM-3
CLM-10-LPB	10	9.982	Standard	12	16	16.043	22	16	12	LSM-3
CLM-12-LPB	12	11.982	Standard	18	20	20.046	26	18	12	LSM-3

PRESS FIT, WITH OVERSIZE ID (INCH)

PART NO.	A DIA		B	C DIA		D DIA	E	F	MATCHING P BUSHING FOR BOTTOM PLATE
	NOMINAL	ACTUAL		NOMINAL	ACTUAL				
CL-4-LPB-OS	1/4	.2643	.31	13/32	.4078	13/16	.62	.44	—
CL-5-LPB-OS	5/16	.3268	.31	1/2	.5017	13/16	.62	.44	—
CL-6-LPB-OS	3/8	.3893	.31	5/8	.6267	13/16	.62	.44	—
CL-8-LPB-OS	1/2	.5143	.50	3/4	.7518	1-1/16	.75	.44	—

PRESS FIT, WITH OVERSIZE ID (METRIC)

PART NO.	A DIA (mm)		B LENGTH UNDER HEAD (mm)	C DIA (mm)		D DIA (mm)	E (mm)	F (mm)	LOCKSCREW (ORDER SEPARATELY)	
	NOMINAL	ACTUAL		NOMINAL	ACTUAL					
CLM-6-LPB-OS	6	7	Standard	8	10	10.038	22	16	12	LSM-3
CLM-8-LPB-OS	8	9	Standard	10	13	13.043	22	16	12	LSM-3
CLM-10-LPB-OS	10	11	Standard	12	16	16.043	22	16	12	LSM-3
CLM-12-LPB-OS	12	13	Standard	18	20	20.046	26	18	12	LSM-3

Also available in threaded version!

Locking-Pin Bushings are now optionally available with a threaded OD, for installation in a tapped hole. This version is designed for use with clamping pins in non-locating applications, with an ID size .040" over nominal size.

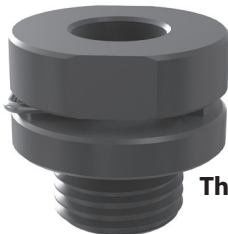

Threaded

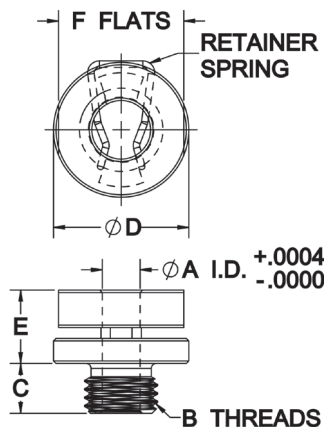

THREADED, WITH OVERSIZE ID (INCH)

PART NO.	A DIA		B THREAD	C	D DIA	E	F
	NOMINAL	ACTUAL					
CL-3-TLPB-OS	3/16	.2268	7/16-20				
CL-4-TLPB-OS	1/4	.2893	1/2-20	.300	.81	.44	3/4
CL-5-TLPB-OS	5/16	.3518	9/16-18				
CL-6-TLPB-OS	3/8	.4143	5/8-18	.350			
CL-8-TLPB-OS	1/2	.5393	3/4-16	.375	1.06		1

THREADED, WITH OVERSIZE ID (METRIC)

PART NO.	A DIA NOMINAL (mm)	A DIA ACTUAL OVERSIZE (mm)	B THREAD	THREAD PITCH (mm)	C (mm)	D DIA (mm)	E (mm)	F (mm)
CLM-6-TLPB-OS	6	7	M12x1.25	1.25	7.6	22	12	20
CLM-8-TLPB-OS	8	9	M16x1.5	1.5	7.6	22	12	20
CLM-10-TLPB-OS	10	11	M18x1.5	1.5	8.9	22	12	20
CLM-12-TLPB-OS	12	13	M20x1.5	1.5	8.9	26	12	24

SLOTTED LOCATOR BUSHINGS

STEEL: TOOL STEEL, HEAT TREATED RC 58-62, BLACK OXIDE FINISH
 STAINLESS: 440C STAINLESS STEEL, HEAT TREATED

1

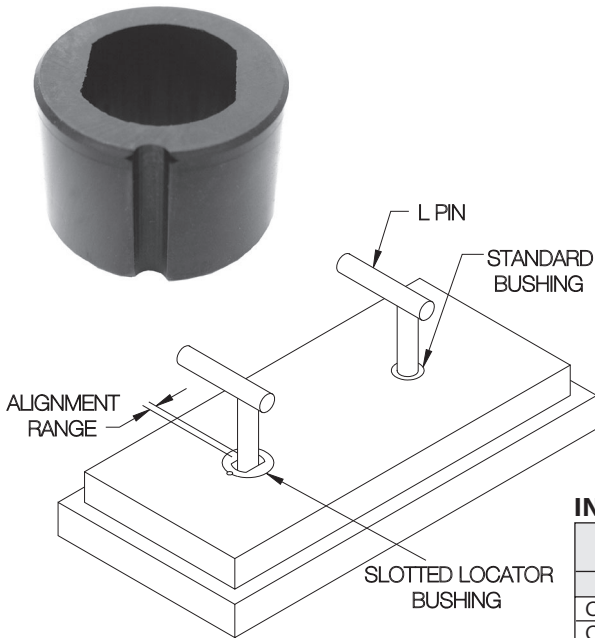

Use with L Pins, T Pins, Shoulder Pins, or Carr Lock® Clamps to align two holes without binding. Precision bushing with a tight tolerance in one direction and full relief in the perpendicular direction. Available for 1/8 through 1" diameter pins (5mm-25mm in metric sizes). To install, first drill and ream hole for roll pin (furnished), then bore large bushing hole for .0003-.0005 press fit. Press in bushing and roll pin simultaneously for accurate orientation. **Patent no. 3,381,554.**

INCH

PART NO.		PIN DIA	A	B DIA	C DIA	L	M DIA	N
STEEL	STAINLESS							
CL-2-SLLB	—	1/8	.1251/.1257	.250	.7500	.40	3/16	3/8
CL-3-SLLB-.1285	—	#30	.1286/.1292	.312	.7500	.40		
CL-3-SLLB-.1562	—	5/32	.1563/.1569	.312	.7500	.40		
CL-3-SLLB	CL-3-SLLB-S	3/16	.1876/.1882	.312	.7500	.40		
CL-4-SLLB-.1910	—	#11	.1911/.1917	.375	.7500	.40		
CL-4-SLLB-.1935	—	#10	.1936/.1942	.375	.7500	.40		
CL-4-SLLB-.1960	—	#9	.1961/.1967	.375	.7500	.40		
CL-4-SLLB-.2188	—	7/32	.2189/.2195	.375	.7500	.40		
CL-4-SLLB	CL-4-SLLB-S	1/4	.2501/.2507	.375	.7500	.40		
CL-4A-SLLB	—				1.0000			
CL-5-SLLB-.2570	—	F	.2571/.2577	.437	1.0000	.40		
CL-5-SLLB-.2812	—	9/32	.2813/.2819	.437	1.0000	.40		
CL-5-SLLB	CL-5-SLLB-S	5/16	.3126/.3132	.437	1.0000	.40		
CL-6-SLLB	CL-6-SLLB-S	3/8	.3751/.3757	.500	1.0000	.40		
CL-8A-SLLB	CL-8A-SLLB-S	1/2	.5001/.5007	.625		.90		
CL-8-SLLB	—							
CL-10-SLLB	CL-10-SLLB-S	5/8	.6251/.6257	.750	1.2500	.90		
CL-12-SLLB	CL-12-SLLB-S	3/4	.7501/.7510	.812	1.5000	.98		
CL-14-SLLB	—	7/8	.8751/.8760	1.000	1.5000	.98		
CL-16-SLLB	—	1	1.0001/1.0010	1.062	1.5000	.98		

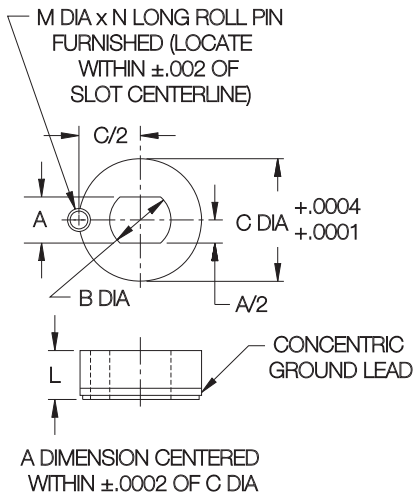

METRIC

PART NO. Steel	Stainless Steel	PIN DIA (mm)	A (mm)	B DIA (mm)	C DIA (mm)	L (mm)	M DIA (mm)	N (mm)
CLM-5-SLLB	—	5	5.003 / 5.028	8	20	9	5	8
CLM-6-SLLB	CLM-6-SLLB-S	6	6.003 / 6.028	9	20	9	5	8
CLM-8-SLLB	CLM-8-SLLB-S	8	8.003 / 8.028	11	24	9	5	8
CLM-10-SLLB	CLM-10-SLLB-S	10	10.003 / 10.028	13	24	9	5	8
CLM-12-SLLB	CLM-12-SLLB-S	12	12.003 / 12.028	15	24	14	5	8
CLM-16-SLLB	CLM-16-SLLB-S	16	16.003 / 16.028	18	30	12	5	8
CLM-20-SLLB	CLM-20-SLLB-S	20	20.003 / 20.028	22	36	19	5	8
CLM-25-SLLB	CLM-25-SLLB-S	25	25.003 / 25.028	27	40	19	5	8

CARBIDE (INCH)

PART NO.	PIN DIA	A	B DIA	C DIA	L	M DIA	N
CL-4-CSLB	1/4	.2501/.2507	.375	.7500	.40	3/16	3/8
CL-5-CSLB	5/16	.3126/.3132	.437				
CL-6-CSLB	3/8	.3751/.3757	.500				
CL-8A-CSLB	1/2	.5001/.5007	.625				

MULTI-ANGLE SLOTTED LOCATOR BUSHINGS

440C STAINLESS STEEL, HEAT TREATED, PASSIVATED



New item!

Slotted Locator Bushings can be used with many types of alignment pins and locating pins to align two holes without binding. The multi-angle version shown here can be installed normally (0°) or at a 90° or 45° angle in the same mounting hole without machining a different pin location. Slotted Locator Bushings have a tight tolerance in one direction and full relief in the perpendicular direction. Available for pin diameters from 1/4 to 1/2", in hardened 440C stainless steel. To install, first drill and ream the small hole for the roll pin, then bore the large bushing hole to provide .0003-.0005" press fit. Press in the bushing and roll pin simultaneously for accurate orientation.

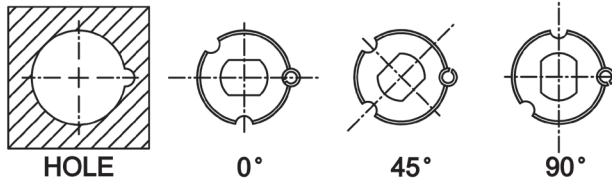
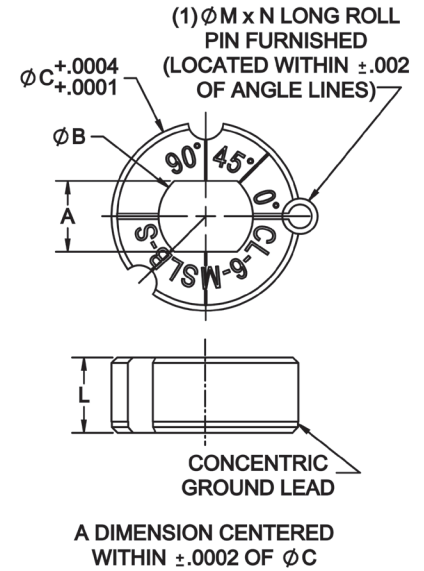

Multi-Angle Slotted Locator Bushings can be installed normally (0°) or at a 90° or 45° angle in the same mounting hole without machining a different pin location.

INCH

PART NO.	PIN DIA	A	B DIA	C DIA	L	M DIA	N
CL-4-MSLB-S	1/4	.2501 / .2507	.375	.7500	.40	3/16	3/8
CL-5-MSLB-S	5/16	.3126 / .3132	.437	1.0000			
CL-6-MSLB-S	3/8	.3751 / .3757	.500	1.0000			
CL-8A-MSLB-S	1/2	.5001 / .5007	.625	1.0000			

KNURLED SLOTTED LOCATOR BUSHINGS

TOOL STEEL, HEAT TREATED RC 58-62, BLACK OXIDE FINISH

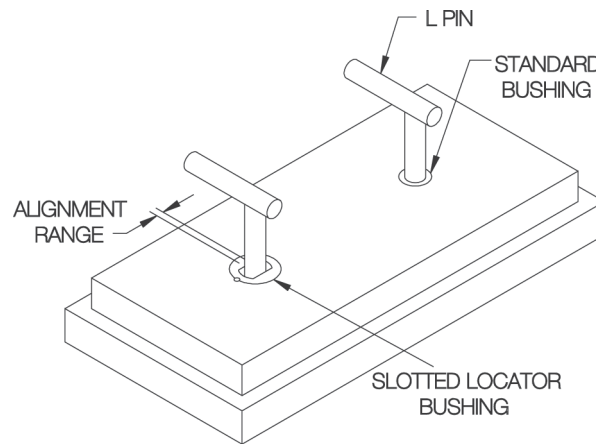
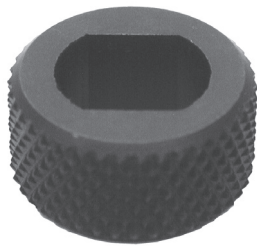

Slotted Locator Bushings with a knurled design for embedding in plastic tooling. Use with L Pins, T Pins, and Shoulder Pins to align two holes without binding. Precision bushing with a tight tolerance in one direction and full relief in the perpendicular direction. Available for 3/16 through 1/2" pin diameters.

INCH

PART NO.	PIN DIA	A	B DIA	C DIA	L
CL-30-SLLB	3/16	.188	.312	.565	1/2
CL-40-SLLB	1/4	.250	.375	.640	
CL-50-SLLB	5/16	.313	.437	.765	
CL-60-SLLB	3/8	.375	.500	.890	
CL-80-SLLB	1/2	.500	.625	1.015	

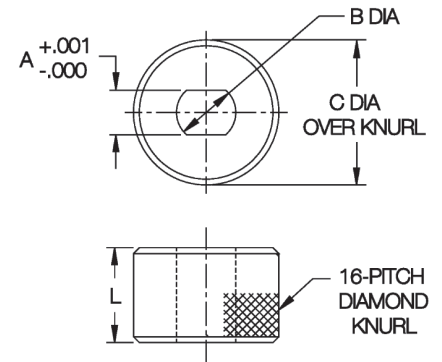

HEADED SLOTTED LOCATOR BUSHINGS

STEEL: TOOL STEEL, HEAT TREATED RC 58-62, BLACK OXIDE FINISH
 STAINLESS STEEL: 440C STAINLESS STEEL, HEAT TREATED

1

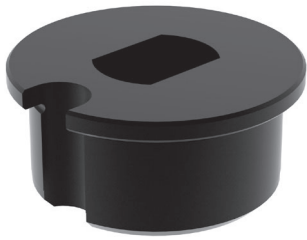

Slotted Locator Bushings can be used with many types of alignment pins and locating pins to align two holes without binding. Precision bushing with a tight tolerance in one direction and full relief in the perpendicular direction. Many sizes are optionally available in hardened 440C stainless steel as well as carbide. Made in USA.

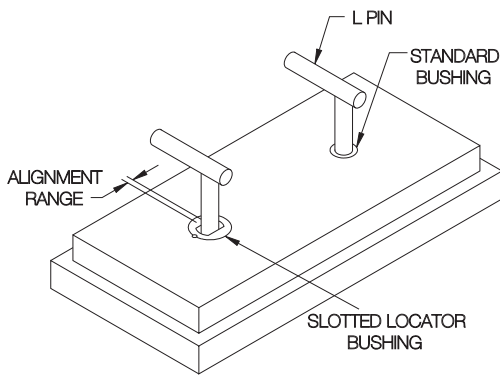
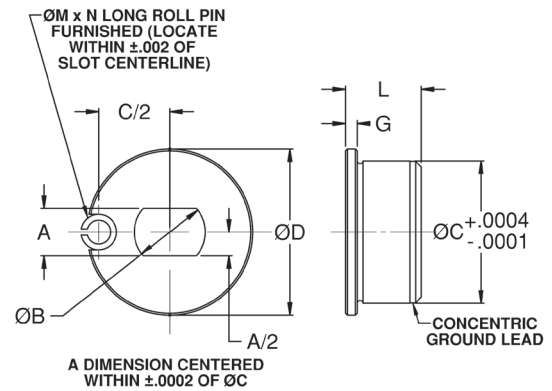

STEEL (INCH)

PART NO.	PIN DIA	A	B DIA	C DIA	D DIA	G	L	M DIA	N
CL-3-HSLB	3/16	.1876/.1882	.312	.7500	.875	.0625	.40	3/16	3/8
CL-4-HSLB	1/4	.2501/.2507	.375						
CL-4A-HSLB									
CL-5-HSLB	5/16	.3126/.3132	.437	1.0000	1.125		.90		
CL-6-HSLB	3/8	.3751/.3757	.500						
CL-8-HSLB	1/2	.5001/.5007	.625						
CL-8B-HSLB									

STAINLESS STEEL (INCH)

PART NO.	PIN DIA	A	B DIA	C DIA	D DIA	G	L	M DIA	N
CL-3-HSLB-S	3/16	.1876/.1882	.312	.7500	.875	.0625	.40	3/16	3/8
CL-4-HSLB-S	1/4	.2501/.2507	.375						
CL-4A-HSLB-S									
CL-5-HSLB-S	5/16	.3126/.3132	.437	1.0000	1.125		.90		
CL-6-HSLB-S	3/8	.3751/.3757	.500						
CL-8-HSLB-S	1/2	.5001/.5007	.625						
CL-8B-HSLB-S									

SLOTTED LOCATOR TEMPLATE BUSHINGS

BUSHING: 1144 STEEL, CARBURIZED-HARDENED
RETAINER RING: ALUMINUM



Retainer Ring

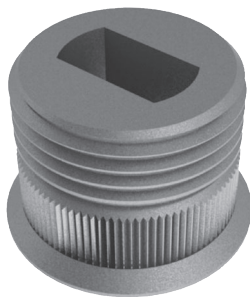

Bushing

These Slotted Locator Bushings are designed for thin template jig plates from 3/64" to 3/8" thick. Use with L Pins, T Pins, or Shoulder Pins to align two holes without binding. Precision bushing with a tight tolerance in one direction and full relief in the perpendicular direction. Bushings are held in place by a threaded Retainer Ring (order separately). Flush contact of the Retainer Ring against the jig plate ensures perpendicularity. OD serrations prevent the bushing from rotating. Threaded Template Bushings can be easily removed to replace or reuse. Available for pin diameters from 3/16 to 3/4".

To install, drill hole in jig plate to nominal bushing OD (B diameter). Countersink 90° to allow bushing to seat flush to .015" below surface of plate. Install and tighten Retainer Ring to secure. To make Retainer Ring installation easier, we offer a handy Socket-Type Installation Tool that fits 1/4" square drives.

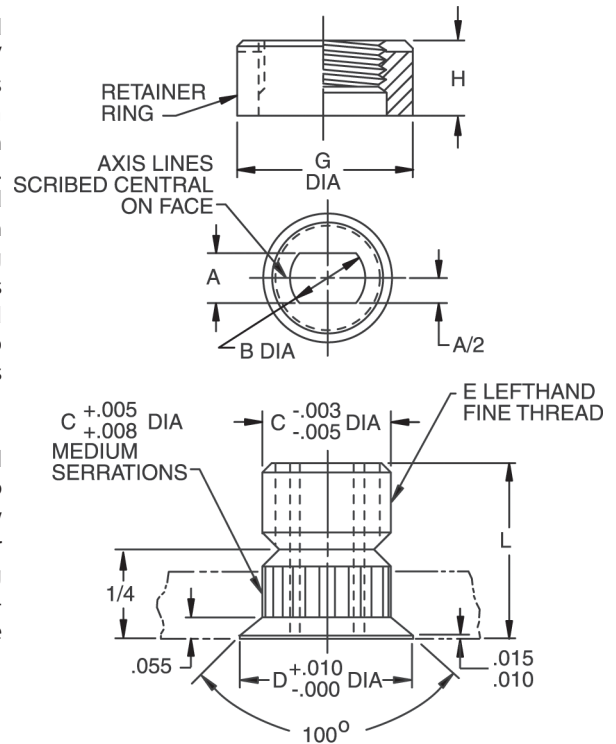

INCH

PART NO.	PIN DIA	A	B DIA	C DIA	D DIA	E	L	RETAINER RING PART NO.	TEMPLATE THICKNESS	G DIA	H
CL-40-SLTB-.1875	3/16	.1876/.1882	3/8	.625	.725	5/8-18 LH	1/2	TTR-40-6	.047-.125	3/4	3/8
								TTR-40-5	.126-.188		5/16
								TTR-40-3	.189-.375		3/16
CL-40-SLTB-.1935	#10	.1936/.1942	3/8	.625	.725	5/8-18 LH	1/2	TTR-40-6	.047-.125	3/4	3/8
								TTR-40-5	.126-.188		5/16
								TTR-40-3	.189-.375		3/16
CL-40-SLTB-.2500	1/4	.2501/.2507	3/8	.625	.725	5/8-18 LH	1/2	TTR-40-6	.047-.125	3/4	3/8
								TTR-40-5	.126-.188		5/16
								TTR-40-3	.189-.375		3/16
CL-48-SLTB-.3125	5/16	.3126/.3132	7/16	.750	.850	3/4-16 LH	1/2	TTR-48-6	.047-.125	1	3/8
								TTR-48-5	.126-.188		5/16
								TTR-48-3	.189-.375		3/16
CL-48-SLTB-.3750	3/8	.3752/.3757	1/2	.750	.850	3/4-16 LH	1/2	TTR-48-6	.047-.125	1	3/8
								TTR-48-5	.126-.188		5/16
								TTR-48-3	.189-.375		3/16
CL-48-SLTB-.5000	1/2	.5001/.5007	5/8	.750	.850	3/4-16 LH	1/2	TTR-48-6	.047-.125	1	3/8
								TTR-48-5	.126-.188		5/16
								TTR-48-3	.189-.375		3/16
CL-64-SLTB-.6250	5/8	.6251/.6257	3/4	1.000	1.100	1"-14 LH	5/8	TTR-64-6	.047-.125	1-1/4	3/8
								TTR-64-5	.126-.188		5/16
								TTR-64-3	.189-.375		3/16
CL-64-SLTB-.7500	3/4	.7501/.7510	13/16	1.000	1.100	1"-14 LH	5/8	TTR-64-6	.047-.125	1-1/4	3/8
								TTR-64-5	.126-.188		5/16
								TTR-64-3	.189-.375		3/16

BALL LOCK PINS

1

TECHNICAL INFORMATION

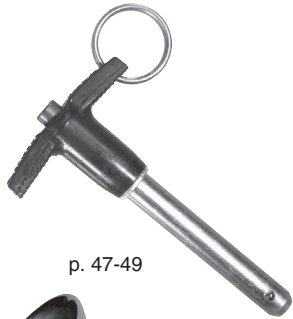

p. 47-49



p. 50-51

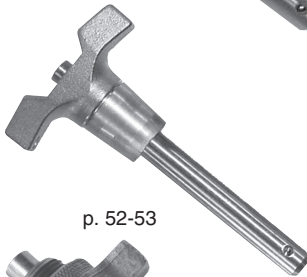

p. 52-53



p. 54-55



p. 56-57



p. 58-59

BALL LOCK PINS

Precision alignment pin with a ground shank. This popular single-acting type is positive locking until released by pushing the button, which moves the center spindle forward to allow the locking balls to retract into a radial groove. Widest range of types and sizes, in steel or stainless steel. Choice of four handle styles: T, L, Button, and Ring. Standard shank diameters from 3/16 to 1" (5 to 20mm in metric). Any grip length up to 6" (150mm in metric) is available as standard, at no extra charge. Available from stock in many standard grip lengths, or quickly made to order in custom lengths and diameters.

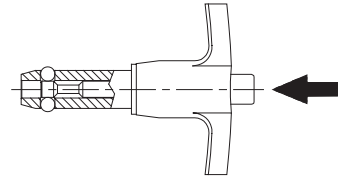

MARINE BALL LOCK PINS

Similar to our standard single-acting Ball Lock Pins in stainless steel, except this type has its handle and button made of 300-series stainless steel. Choice of two handle styles: Recessed Button and Ring. Shank diameters from 3/16 to 1/2", each available in a choice of several standard grip lengths. Available from stock only (not made to order).

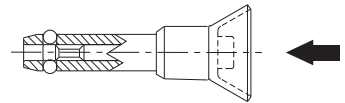

HEAVY-DUTY BALL LOCK PINS

Similar to our standard single-acting Ball Lock Pins, except with a heavier handle for rough service. Available only in stainless steel. Handles are made of solid stainless steel for maximum impact strength and are specially shaped to prevent accidentally pressing the release button. Choice of four handle styles: T, L, Button, and Ring. Shank diameters from 3/16 to 1/2" (5 to 12mm in metric), each in a choice of several standard grip lengths. Available from stock only (not made to order).

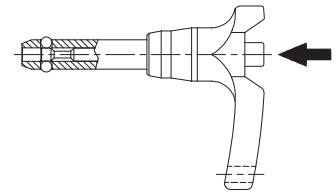

ADJUSTABLE BALL LOCK PINS

These Ball Lock Pins have an adjustable grip length. They can be used for clamping, or simply to provide a variable grip length. The threaded handle turns to provide a 1/2" clamping range or adjustment range. Available in steel or stainless steel. Choice of three handle styles: Knob, T, and L. Standard shank diameters from 1/4 to 1" (6 to 20mm in metric), each in a choice of many standard grip lengths. Other grip lengths are available as specials (extra charge and longer delivery time).

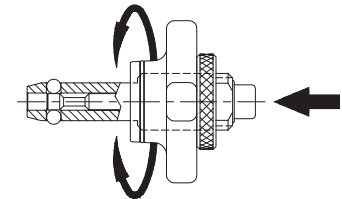

DOUBLE-ACTING BALL LOCK PINS

Similar to a single-acting pin, except the center spindle has two grooves instead of one, to release the ball by either pushing or pulling. Pushing on the handle releases the balls and inserts the pin in one motion. Pulling on the handle releases the balls and removes the pin in one motion. Available in steel or stainless steel. Choice of three handle styles: T, L, and Ring. Standard shank diameters from 3/16 to 1" (5 to 20mm in metric). Any grip length up to 6" (150mm in metric) is available as a standard, at no extra charge. Available from stock in some standard grip lengths, or quickly made to order in custom lengths and diameters.

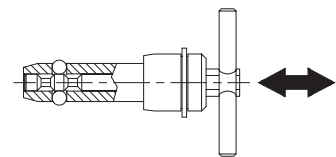

LIFTING PINS

A single-acting ball lock pin with a solid, one-piece body and four balls for high tension loads. Positive locking until released by pushing the button. Sturdy forged shackle for heavy lifting. Shank diameters from 1/4 to 1", each in a choice of several standard grip lengths. Available from stock only (not made to order).

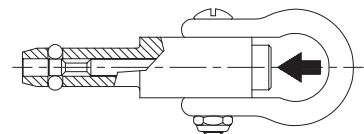

BALL LOCK PINS

STRENGTH DATA (INCH)

NOM. DIA	ALLOWABLE HOLE DIA		BLP, BPD, ABP APPROXIMATE PULL OUT STRENGTH (LBS)	BLP, BPD, ABP, LFP CALCULATED DOUBLE SHEAR STRENGTH (LBS)***		DEP CALCULATED DOUBLE SHEAR STRENGTH (LBS)***		BLP, BPD APPROX. WEIGHT (OUNCES)		DEP INSERTION/REMOVAL FORCE (LBS)	
	MAX	MIN		STEEL	STAINLESS	STEEL	STAINLESS	HANDLE	PER IN.	MAX	MIN
3/16 (#10)	.194	.190	200	2,100	2,300	2,200	2,000	1.25	.15	7	2
1/4	.254	.250	230	4,000	4,500	4,200	2,200	1.75	.25	7	2
5/16	.317	.313	510	6,000	7,100	6,700	3,500	2.00	.40	14	6
3/8	.379	.375	575	9,200	10,200	9,700	5,000	2.40	.50	14	6
7/16	.443	.438	710	12,300	13,600	13,200	7,000	2.90	.62	17	8
1/2	.505	.500	1160	16,000	18,000	17,500	9,200	3.40	.80	22	10
9/16	.568	.563	1420	20,500	23,000	22,000	11,500	3.65	1.20	22	10
5/8	.630	.625	2070	25,500	28,700	27,500	13,500	4.00	1.35	30	15
3/4	.757	.750	2970	36,700	41,000	39,500	20,500	4.25	2.30	30	15
7/8	.882	.875	3900	50,000	56,200	50,000	28,500	8.31	2.73	35	20
1	1.010	1.000	5400	65,500	73,500	70,700	37,200	9.00	3.47	40	20

STRENGTH DATA (METRIC)

NOM. DIA	ALLOWABLE HOLE DIA		BLP, BPD, ABP APPROXIMATE PULL OUT STRENGTH (LBS)	BLP, BPD, ABP, LFP CALCULATED DOUBLE SHEAR STRENGTH (LBS)***		DEP CALCULATED DOUBLE SHEAR STRENGTH (LBS)***		BLP, BPD APPROX. WEIGHT (OUNCES)		DEP INSERTION/REMOVAL FORCE (LBS)	
	MAX	MIN		STEEL	STAINLESS	STEEL	STAINLESS	HANDLE	PER IN.	MAX	MIN
5mm	.201	.197	230	2,600	3,000	2,500	1,400	1.25	.15	7	2
6mm	.240	.236	230	4,000	4,400	4,000	2,100	1.75	.25	7	2
8mm	.319	.315	510	7,000	8,000	7,200	3,700	2.00	.40	14	6
10mm	.398	.394	710	11,000	12,500	11,400	5,800	2.40	.50	14	6
12mm	.477	.472	1160	16,000	18,000	16,500	8,500	3.40	.80	22	10
16mm	.635	.630	2070	29,000	32,500	29,500	15,400	4.00	1.35	30	15
20mm	.794	.787	2970	45,200	50,900	46,100	21,600	4.25	2.30	30	15

**Pins with grip lengths over 8" (special) are not heat treated, in order to maintain straightness. Double shear strength will be reduced approximately 20-50%. Steel pins over 8" long will have a black oxide finish instead of plating. Pins in larger diameters than listed here are available as specials (may be made from alternate steels).
 ***2:1 Safety factor

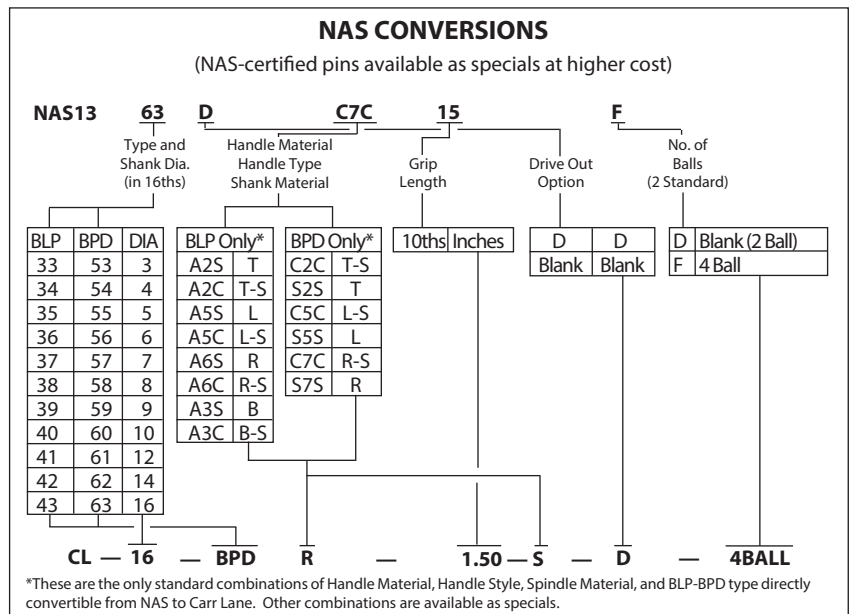
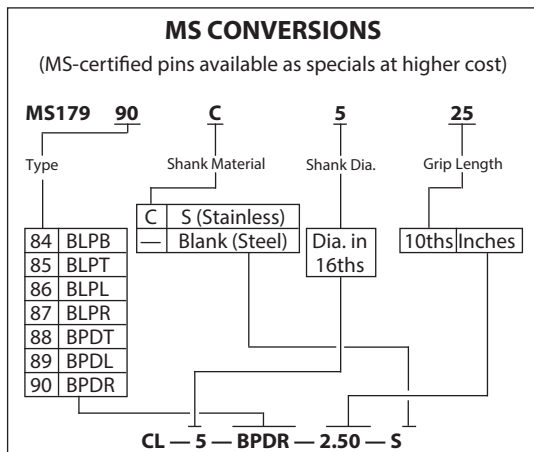

BALL LOCK PINS

1



T Handle

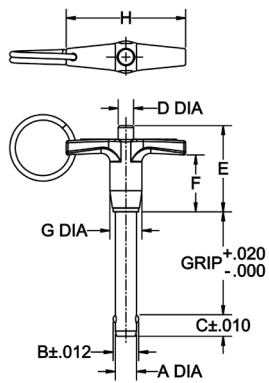

BLPT



L Handle

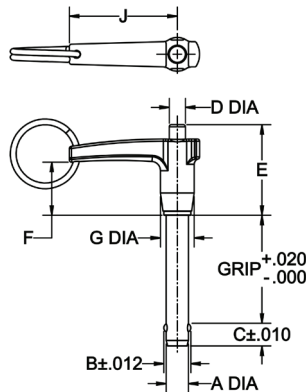

BLPL



Button Handle

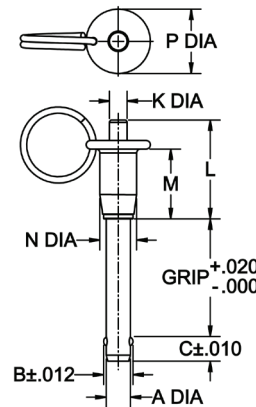

BLPB



Ring Handle

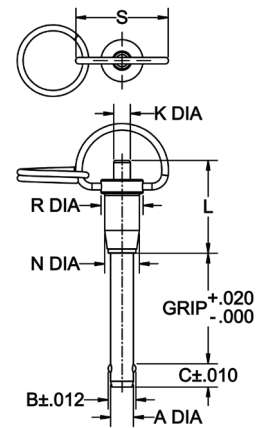

BLPR

INCH

PART NO.	A DIA		B	C	D DIA	E	F	G DIA	H	J	K DIA	L	M	N DIA	P DIA	R DIA	S
	NOMINAL	ACTUAL															
CL- 3-BLPx-x.xx	3/16 (#10)	.1885/.1870	.219	.245	.22	1.26	.78	.47	1.75	1.50	.22	1.26	.89	.47	.82	.57	1.13
CL- 4-BLPx-x.xx	1/4	.2485/.2470	.290	.275	.22	1.26	.78	.47	1.75	1.50	.22	1.26	.89	.47	.82	.57	1.13
CL- 5-BLPx-x.xx	5/16	.3110/.3095	.375	.315	.22	1.26	.78	.47	1.75	1.50	.22	1.26	.89	.47	.82	.57	1.13
CL- 6-BLPx-x.xx	3/8	.3735/.3720	.438	.350	.27	1.47	.94	.59	2.00	1.62	.27	1.47	1.02	.59	1.00	.69	1.13
CL- 7-BLPx-x.xx	7/16	.4360/.4345	.508	.365	.27	1.47	.94	.59	2.00	1.62	.27	1.47	1.02	.59	1.00	.69	1.13
CL- 8-BLPx-x.xx	1/2	.4985/.4970	.592	.445	.39	1.61	1.06	.75	2.25	1.88	.39	1.61	1.08	.75	1.31	.82	1.33
CL- 9-BLPx-x.xx	9/16	.5610/.5595	.666	.495	.39	1.61	1.06	.75	2.25	1.88	.39	1.61	1.08	.75	1.31	.82	1.33
CL-10-BLPx-x.xx	5/8	.6235/.6220	.750	.565	.50	1.81	1.06	.93	3.00	2.50	.50	1.81	1.25	.93	1.56	1.01	1.33
CL-12-BLPx-x.xx	3/4	.7485/.7470	.886	.655	.50	1.81	1.06	.93	3.00	2.50	.50	1.81	1.25	.93	1.56	1.01	1.33
CL-14-BLPx-x.xx	7/8	.8735/.8720	1.044	.745	.71	2.07	1.25	1.31	3.50	2.90	.71	2.07	1.49	1.31	2.16	1.41	1.90
CL-16-BLPx-x.xx	1	.9985/.9970	1.217	.875	.71	2.07	1.25	1.31	3.50	2.90	.71	2.07	1.49	1.31	2.16	1.41	1.90

METRIC

BASIC PART NO.	A DIA (mm)	A DIA ACTUAL (mm)	B (mm)	C (mm)	D DIA (mm)	E (mm)	F (mm)	G DIA (mm)	H (mm)
CLM-5-BLPx-xx	5	4.96 / 4.92	5.38	6.22	5.5	32	20	12	44.5
CLM-6-BLPx-xx	6	5.96 / 5.92	7.06	6.99	5.5	32	20	12	44.5
CLM-8-BLPTx-xx	8	7.96 / 7.92	9.42	8.00	5.5	32	20	12	44.5
CLM-10-BLPTx-xx	10	9.96 / 9.92	11.91	8.89	7	37.5	24	15	51
CLM-12-BLPx-xx	12	11.96 / 11.92	14.40	11.30	7	37.5	24	15	51
CLM-16-BLPx-xx	16	15.96 / 15.92	19.00	14.35	12.5	46	27	23.5	76
CLM-20-BLPx-xx	20	19.96 / 19.92	24.08	20.19	12.5	46	27	23.5	76

BALL LOCK PINS

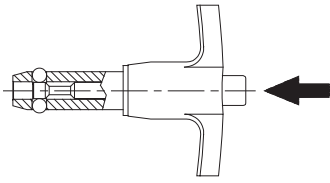

SHANK (STEEL): 4130 STEEL, HEAT TREATED RC 36-40, ZINC PLATED YELLOW CHROMATE;
 SHANK (STAINLESS STEEL): 17-4PH STAINLESS STEEL, HEAT TREATED RC 40 MIN, PASSIVATED;
 SPINDLE: 17-4PH STAINLESS STEEL, PASSIVATED; HANDLE: ALUMINUM ALLOY, BLACK FINISH;
 BUTTON: ALUMINUM ALLOY, ANODIZED; COLLAR: 300-SERIES STAINLESS STEEL, PASSIVATED;
 SPRING & RING: 302 STAINLESS STEEL; BALLS: 440C STAINLESS STEEL

Precision alignment pin with a ground shank. This popular single-acting type is positive locking until released by pushing the button, which moves the center spindle forward to allow the locking balls to retract into a radial groove. Widest range of types and sizes, in steel or stainless steel. Choice of four handle styles: T, L, Button, and Ring. Standard shank diameters from 3/16 to 1" (5 to 20mm in metric). Any grip length up to 6" (150mm in metric) is available as standard, at no extra charge. Available from stock in many standard grip lengths, or quickly made to order in custom lengths and diameters.



Options

Ball Lock Pins are optionally available in stainless steel instead of alloy steel for greater corrosion resistance. (Note: Both types have aluminum handles, and buttons.) Pins are also available with four balls instead of two, as specials, for more-distributed ball-contact force.

The optional attached Cable Assembly (-C) is 12" long (part no. CL-82-KA-12.0 if ordered separately), while the optional attached Nylon Lanyard (-NL) is 10" long (part no. CL-1-NL-10 if ordered separately). Both have an eyelet at the free end for a #10 or M5 attachment screw.

Ordering Example (INCH):

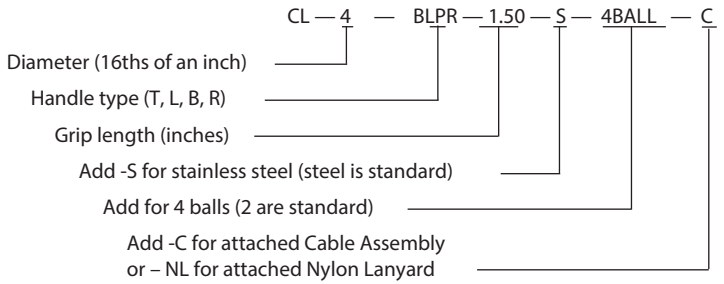

Ordering Example (Metric):

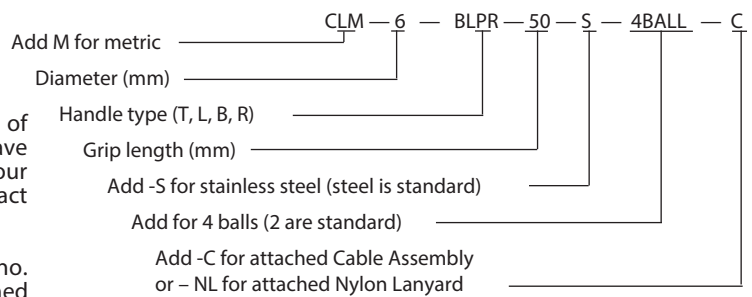

STOCK GRIP LENGTHS (INCH)

PART NO. CL-X-BLP-x.xx	NOMINAL SHANK DIA	GRIP LENGTH (INCHES)																															
		0.50		0.75		1.00		1.25		1.50		1.75		2.00		2.25		2.50		3.00		3.50		4.00		4.50		5.00		5.50		6.00	
		T	L	B	R	T	L	B	R	T	L	B	R	T	L	B	R	T	L	B	R	T	L	B	R	T	L	B	R	T	L	B	R
CL-3-BLP ...	3/16(#10)	*	*	*	*	*	*	X	X	X	X	X	X	*	*	*	X	X	X	*	*	X	X	*	*	*	*	*	*	*	*	*	*
CL-4-BLP ...	1/4	X	X	X	X	X	X	X	X	X	X	X	X	*	*	X	X	X	X	X	X	X	X	X	X	X	X	X	X	X	X	X	
CL-5-BLP ...	5/16	*	*	*	*	X	X	X	X	X	X	X	X	*	*	X	X	X	X	X	X	X	X	X	X	X	X	X	X	X	X	X	
CL-6-BLP ...	3/8	*	*	*	X	*	*	X	X	X	X	X	X	*	*	X	X	X	X	X	X	X	X	X	X	X	X	X	X	X	X	X	
CL-7-BLP ...	7/16	*	*	*	*	*	*	*	*	*	*	*	*	*	*	*	*	*	*	*	*	*	*	*	*	*	*	*	*	*	*	*	*
CL-8-BLP ...	1/2	*	*	*	*	*	*	X	X	*	*	X	X	X	X	X	X	X	X	X	X	X	X	X	X	X	X	X	X	X	X	X	
CL-9-BLP ...	9/16	*	*	*	*	*	*	*	*	*	*	*	*	*	*	*	*	*	*	*	*	*	*	*	*	*	*	*	*	*	*	*	*
CL-10-BLP ...	5/8	*	*	*	*	*	*	*	*	*	*	*	*	*	*	*	X	*	*	*	*	*	*	*	*	*	*	*	*	*	*	*	*
CL-12-BLP ...	3/4	*	*	*	*	*	*	*	*	*	*	*	*	*	*	X	*	*	*	*	*	*	*	*	*	*	*	*	*	*	*	*	*
CL-14-BLP ...	7/8	*	*	*	*	*	*	*	*	*	*	*	*	*	*	X	*	*	*	*	*	*	*	*	*	*	*	*	*	*	*	*	*
CL-16-BLP ...	1	*	*	*	*	*	*	*	*	*	*	*	*	*	*	X	*	*	*	*	*	*	*	*	*	*	*	*	*	*	*	*	*

STOCK GRIP LENGTHS (METRIC)

PART NO.	NOMINAL SHANK DIA	GRIP LENGTH (mm)																																	
		10		15		20		25		30		40		50		80		100																	
		T	L	B	R	T	L	B	R	T	L	B	R	T	L	B	R	T	L	B	R														
CLM-5-BLPx-x.xx	5mm																																		
CLM-6-BLPx-x.xx	6mm	*	*			*	*			*	*			*	*			*	*			*	*			*	*			*	*			*	*
CLM-8-BLPx-x.xx	8mm					*	*			*	*			*	*			*	*			*	*			*	*			*	*			*	*
CLM-10-BLPx-x.xx	10mm					*	*			*	*			*	*			*	*			*	*			*	*			*	*			*	*
CLM-12-BLPx-x.xx	12mm					*	*			*	*			*	*			*	*			*	*			*	*			*	*			*	*
CLM-16-BLPx-x.xx	16mm					*	*			*	*			*	*			*	*			*	*			*	*			*	*			*	*
CLM-20-BLPx-x.xx	20mm					*	*			*	*			*	*			*	*			*	*			*	*			*	*			*	*

* = STOCKED IN ALLOY STEEL ONLY
 X = STOCKED IN ALLOY AND STAINLESS STEEL

MARINE BALL LOCK PINS

1



Button Handle (B)

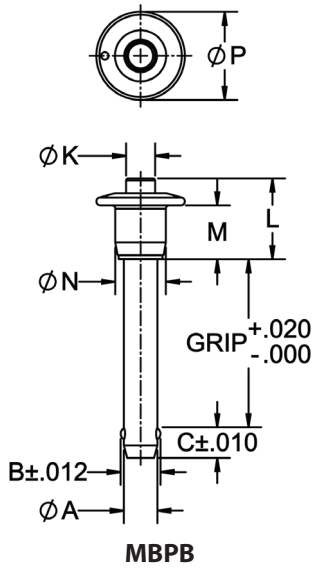

MBPB



Recessed Button Handle (M)

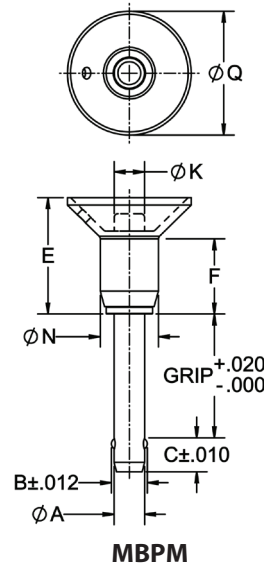

MBPM



Ring Handle (R)

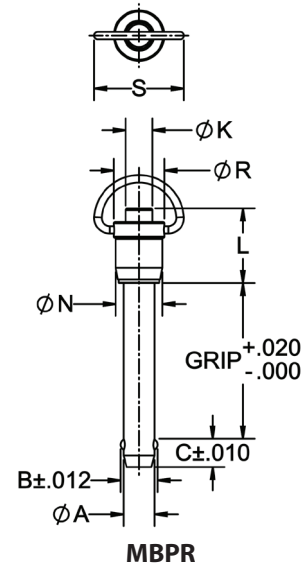

MBPR

INCH

BASIC PART NO.	A DIA		B	C	K DIA	L	M	N DIA	P DIA
	NOMINAL	ACTUAL							
CL-3-MBPB	3/16 (#10)	.1885 / .1870	.219	.245	.25	.81	.56	.47	.79
CL-4-MBPB	1/4	.2485 / .2470	.290	.275	.25	.81	.56	.47	.79
CL-5-MBPB	5/16	.3110 / .3095	.375	.315	.25	.92	.65	.47	.88
CL-6-MBPB	3/8	.3735 / .3720	.438	.350	.31	.98	.65	.59	1.00
CL-8-MBPB	1/2	.4985 / .4970	.592	.455	.44	1.20	.80	.75	1.31
CL-10-MBPB	5/8	.6235 / .6220	.750	.565	.50	1.56	1.00	.93	1.56
CL-12-MBPB	3/4	.7485 / .7470	.886	.655	.50	1.56	1.00	.93	1.56

METRIC

PART NO.	A DIA (mm)		GRIP LENGTH (mm)	B (mm)	C (mm)	K DIA (mm)	L (mm)	M (mm)	N (mm)	P DIA (mm)
	NOMINAL	ACTUAL								
CLM-5-MBPx-xx-S	5	4.96 / 4.92	20	5.38	6.22	5.5	20.5	14	12	20
CLM-5-MBPx-xx-S	5	4.96 / 4.92	25	5.38	6.22	5.5	20.5	14	12	20
CLM-6-MBPx-xx-S	6	5.96 / 5.92	15	7.06	6.99	5.5	20.5	14	12	20
CLM-6-MBPx-xx-S	6	5.96 / 5.92	40	7.06	6.99	5.5	20.5	14	12	20
CLM-6-MBPx-xx-S	6	5.96 / 5.92	50	7.06	6.99	5.5	20.5	14	12	20
CLM-6-MBPx-xx-S	6	5.96 / 5.92	60	7.06	6.99	5.5	20.5	14	12	20
CLM-10-MBPx-xx-S	10	9.96 / 9.92	30	11.91	8.89	7	25	16.5	15	25.5
CLM-12-MBPx-xx-S	12	11.96 / 11.92	50	14.40	11.30	10	30.5	20.5	19	33.5

MARINE BALL LOCK PINS

SHANK: 17-4PH STAINLESS STEEL, HEAT TREATED RC 40 MIN, PASSIVATED
 SPINDLE: 17-4PH STAINLESS STEEL, PASSIVATED
 HANDLE, BUTTON & COLLAR: 300-SERIES STAINLESS STEEL, PASSIVATED
 SPRING & RING: 302 STAINLESS STEEL
 BALLS: 440C STAINLESS STEEL

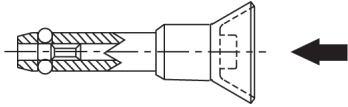

Similar to our standard single-acting Ball Lock Pins in stainless steel, except this type has its handle and button made of 300-series stainless steel. Choice of three handle styles: Buttons, Recessed Button and Ring. Shank diameters from 3/16 to 3/4" (5 to 16mm in metric), each available in a choice of several standard grip lengths. Available from stock only in the standard grip lengths listed below (other grip length available as specials).

Ordering Example (INCH):

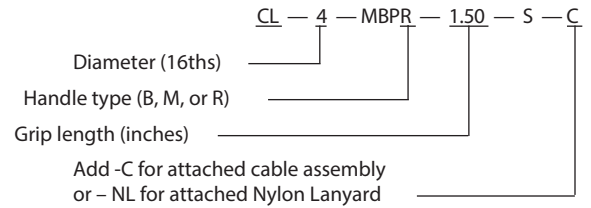

Optional Cable

The optional attached Cable Assembly (-C) is 12" long (part no. CL-82-KA-12.0 if ordered separately), while the optional attached Nylon Lanyard (-NL) is 10" long (part no. CL-1-NL-10 if ordered separately). Both have an eyelet at the free end for a #10 or M5 attachment screw.

Ordering Example (Metric):

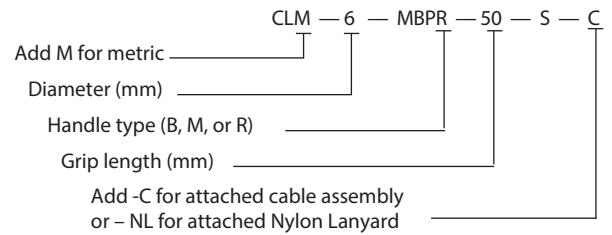

STOCK GRIP LENGTHS (INCH)

PART NO.	NOMINAL SHANK DIA	GRIP LENGTH (INCHES)																																			
		0.50			0.75			1.00			1.25			1.50			1.75			2.00			2.25			2.50			3.00			3.50			4.00		
		B	M	R	B	M	R	B	M	R	B	M	R	B	M	R	B	M	R	B	M	R	B	M	R	B	M	R	B	M	R	B	M	R			
CL-3-MBPx-x.xx-S	3/16 (#10)							•		•										•																	
CL-4-MBPx-x.xx-S	1/4	•			•			•		•	•		•							•		•															
CL-5-MBPx-x.xx-S	5/16							•		•	•		•										•		•	•		•									
CL-6-MBPx-x.xx-S	3/8				•		•	•		•				•		•							•		•	•		•	•		•			•			
CL-8-MBPx-x.xx-S	1/2							•															•		•	•		•									
CL-10-MBPx-x.xx-S	5/8																						•		•	•		•									
CL-12-MBPx-x.xx-S	3/4																																				

STOCK GRIP LENGTHS (METRIC)

PART NO.	NOMINAL SHANK DIA	GRIP LENGTH (mm)																																									
		15						20						25						30						40						50						60					
		B	M	R	B	M	R	B	M	R	B	M	R	B	M	R	B	M	R	B	M	R	B	M	R	B	M	R															
CLM-5-MBPx-x.xx-S	5mm				•		•	•																																			
CLM-6-MBPx-x.xx-S	6mm	•					•																																				
CLM-8-MBPx-x.xx-S	8mm																																										
CLM-10-MBPx-x.xx-S	10mm													•																													
CLM-12-MBPx-x.xx-S	12mm																																										

HEAVY-DUTY BALL LOCK PINS

1



T Handle



L Handle



Button Handle



Ring Handle

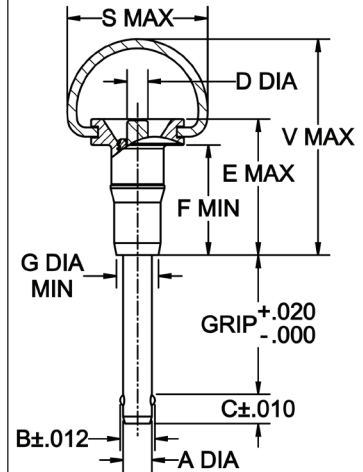
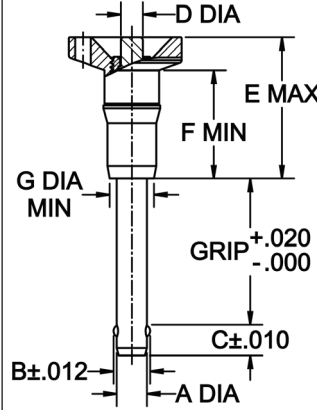
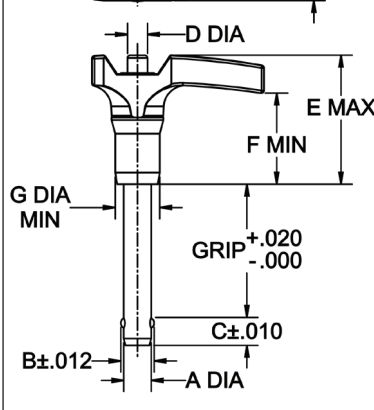
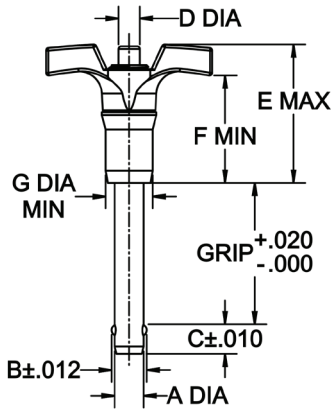
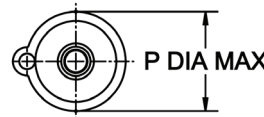
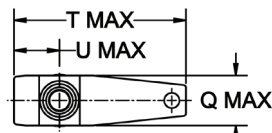
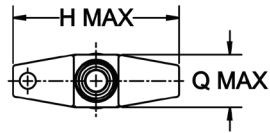

BLHT

BLHL

BLHB

BLHR

INCH

PART NO.	A DIA		B	C	D DIA	E	F	G DIA	H	P DIA	Q	S	T	U	V
	NOMINAL	ACTUAL													
CL-3-BLHx-x.xx-S	3/16 (#10)	.1885/.1870	.220	.245											
CL-4-BLHx-x.xx-S	1/4	.2485/.2470	.289	.275	.25	1.52	.70	.38	1.82	1.07	.63	1.56	1.95	.54	2.13
CL-5-BLHx-x.xx-S	5/16	.3110/.3095	.375	.315											
CL-6-BLHx-x.xx-S	3/8	.3735/.3720	.440	.350											
CL-7-BLHx-x.xx-S	7/16	.4360/.4345	.509	.365	.30	1.47	.85	.51	2.35	1.39	.80	2.00	2.51	.70	2.34
CL-8-BLHx-x.xx-S	1/2	.4985/.4970	.594	.445											

METRIC

CLM-5-BLHx-xx-S	5mm	.1954/.1939	.210	.245											
CLM-6-BLHx-xx-S	6mm	.2347/.2332	.275	.275	.25	.39	.70	.38	1.82	1.07	.63	1.56	1.95	.54	2.13
CLM-8-BLHx-xx-S	8mm	.3135/.3120	.371	.315											
CLM-10-BLHx-xx-S	10mm	.3922/.3907	.467	.350	.30	.37	.85	.51	2.35	1.39	.80	2.00	2.51	.70	2.34
CLM-12-BLHx-xx-S	12mm	.4709/.4694	.569	.445											

ADJUSTABLE BALL LOCK PINS

1



Knob Handle

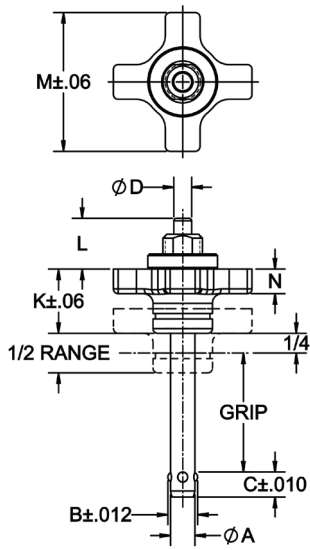

ABPK



T Handle

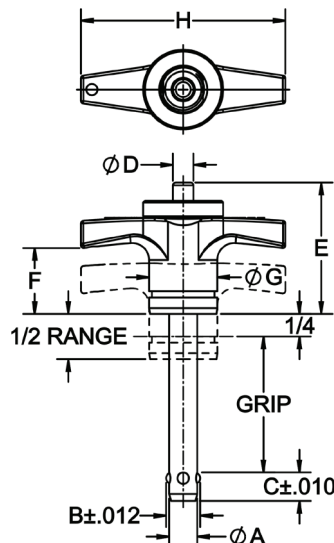

ABPT



L Handle

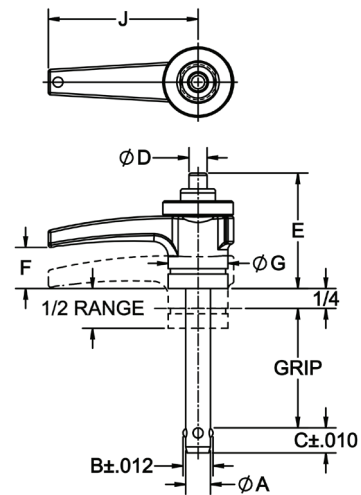

ABPL

INCH

PART NO.	A DIA		B	C	D DIA	E	F	G DIA	H	J	K	L	M	N
	NOMINAL	ACTUAL												
CL-4-ABPx-x.xx-S	1/4	.2485/.2470	.290	.275	.22	1.51	1.06	.75	2.25	1.87	.88	.58	1.75	.38
CL-5-ABPx-x.xx-S	5/16	.3110/.3095	.375	.315		1.45								
CL-6-ABPx-x.xx-S	3/8	.3735/.3720	.438	.350	.27	1.48	1.06	.93	3.00	2.50	.88	.63	2.12	.44
CL-7-ABPx-x.xx-S	7/16	.4360/.4345	.508	.365										
CL-8-ABPx-x.xx-S	1/2	.4985/.4970	.592	.445	.39	1.55	1.06	.93	3.00	2.50	1.00	.55	2.12	.44
CL-9-ABPx-x.xx-S	9/16	.5610/.5595	.666	.495										
CL-10-ABPx-x.xx-S	5/8	.6235/.6220	.750	.565	.50	2.07	1.25	1.31	3.50	2.87	1.25	1.13	2.75	.50
CL-12-ABPx-x.xx-S	3/4	.7485/.7470	.886	.655										
CL-14-ABPx-x.xx-S	7/8	.8735/.8720	1.044	.745	.71	2.34	1.62	1.50	4.30	4.00	1.62	1.00	4.00	.75
CL-16-ABPx-x.xx-S	1	.9985/.9970	1.217	.875										

METRIC

BASIC PART NO.	A DIA (mm)		B (mm)	C (mm)	D DIA (mm)	K (mm)	L (mm)	M (mm)	N (mm)
	NOMINAL	ACTUAL							
CLM-6-ABPx-xx-S	6	5.96 / 5.92	7.06	6.99	5.5	20.5	16.5	44.5	9.5
CLM-8-ABPx-xx-S	8	7.96 / 7.92	9.42	8.00	5.5	20.5	19	44.5	9.5
CLM-10-ABPx-xx-S	10	9.96 / 9.92	11.91	8.89	7	22.5	18.5	54	11
CLM-12-ABPx-xx-S	12	11.96 / 11.92	14.40	11.30	7	25.5	18.5	54	11
CLM-16-ABPx-xx-S	16	15.96 / 15.92	19.00	14.35	12.5	32	28.5	70	12.5
CLM-20-ABPx-xx-S	20	19.96 / 19.92	24.08	20.19	12.5	51	25.5	70	12.5

ADJUSTABLE BALL LOCK PINS

SHANK: 17-4PH STAINLESS STEEL, HEAT TREATED RC 40 MIN, PASSIVATED;
 SPINDLE: 17-4PH STAINLESS STEEL, PASSIVATED;
 T & L HANDLE: ALUMINUM ALLOY, BLACK FINISH; KNOB HANDLE: 319 ALUMINUM ALLOY;
 HEAD & LOCKNUT: 300-SERIES STAINLESS STEEL, PASSIVATED; BUTTON: ALUMINUM ALLOY, ANODIZED;
 SPRING: 302 STAINLESS STEEL; BALLS: 440C STAINLESS STEEL

1

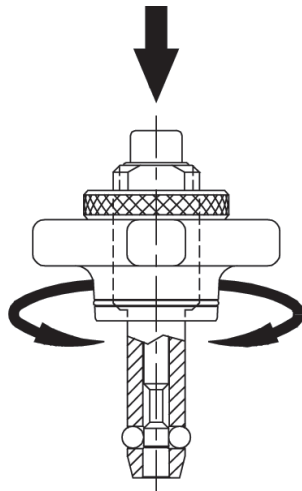

These Ball Lock Pins have an adjustable grip length. They can be used for clamping, or simply to provide a variable grip length. The threaded handle turns to provide a +/- 1/4" clamping range or adjustment range. When used just for variable grip length (not for clamping), the handle can be secured with the supplied knurled locknut. These single-acting pins are manufactured with four balls as standard, instead of two, for more-distributed ball-pullout force in clamping applications. Available in stainless steel only.

Choice of three handle styles: Knob, T, and L. Standard shank diameters from 1/4 to 1" (6 to 20mm in metric), each in a choice of many standard grip lengths. Available from stock only in the standard grip lengths listed below. Other grip lengths are available as specials (extra charge and longer delivery time).

To order pins with a standard Cable Assembly attached (#2 cable size, 12" long, with a terminal at the free end for a #10 or M5 attachment screw), add "-C" to the part number:

CL-4-ABPK-1.50-S-C

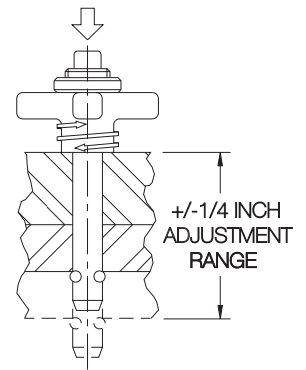

Grip length adjusts +/- 1/4" from nominal.

Adjustable Ball Lock Pins can be used for clamping, or simply to provide a variable grip length.

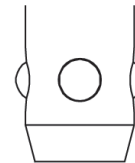

Four balls are standard on Adjustable Ball Lock Pins, to provide more distributed ball-pullout force in clamping applications.

STOCK GRIP LENGTHS (INCH)

PART NO.	NOMINAL SHANK DIA	GRIP LENGTH (INCHES)																												
		0.50		0.75		1.00		1.25		1.50		1.75		2.00		2.50		3.00		3.50		4.00		4.50		5.00		6.00		
		K	T	L	K	T	L	K	T	L	K	T	L	K	T	L	K	T	L	K	T	L	K	T	L	K	T	L	K	T
CL-4-ABPx-x.xx-S	1/4	•	•	•	•	•	•	•	•	•	•	•	•	•	•	•	•	•	•	•	•	•	•	•	•	•	•	•	•	•
CL-5-ABPx-x.xx-S	5/16	•	•	•	•	•	•	•	•	•	•	•	•	•	•	•	•	•	•	•	•	•	•	•	•	•	•	•	•	•
CL-6-ABPx-x.xx-S	3/8	•	•	•	•	•	•	•	•	•	•	•	•	•	•	•	•	•	•	•	•	•	•	•	•	•	•	•	•	•
CL-8-ABPx-x.xx-S	1/2				•	•	•	•	•	•	•	•	•	•	•	•	•	•	•	•	•	•	•	•	•	•	•	•	•	•
CL-9-ABPx-x.xx-S	9/16																													
CL-10-ABPx-x.xx-S	5/8									•	•	•	•	•	•	•	•	•	•	•	•	•	•	•	•	•	•	•	•	•
CL-12-ABPx-x.xx-S	3/4									•	•	•	•	•	•	•	•	•	•	•	•	•	•	•	•	•	•	•	•	•
CL-14-ABPx-x.xx-S	7/8																													
CL-16-ABPx-x.xx-S	1																													

STOCK GRIP LENGTHS (METRIC)

PART NO.	NOMINAL SHANK DIA	GRIP LENGTH (mm)																												
		20		30		40		50																						
		K	T	L	K	T	L	K	T	L																				
CLM-6-ABPx-x.xx-S	6mm	•	•	•	•	•	•	•	•	•	•	•	•	•	•	•	•	•	•	•	•	•	•	•	•	•	•	•	•	•
CLM-8-ABPx-x.xx-S	8mm	•	•	•	•	•	•	•	•	•	•	•	•	•	•	•	•	•	•	•	•	•	•	•	•	•	•	•	•	•
CLM-10-ABPx-x.xx-S	10mm				•	•	•	•	•	•	•	•	•	•	•	•	•	•	•	•	•	•	•	•	•	•	•	•	•	•

DOUBLE-ACTING BALL LOCK PINS

1

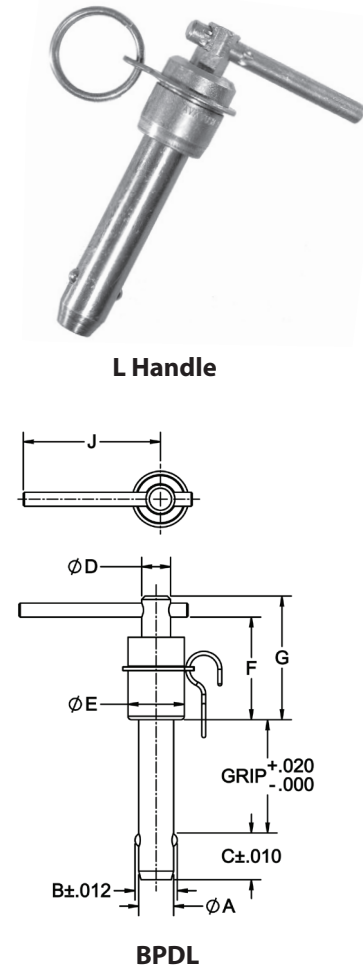
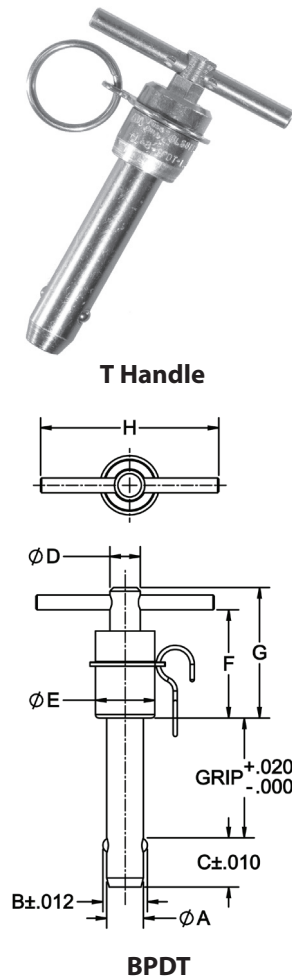
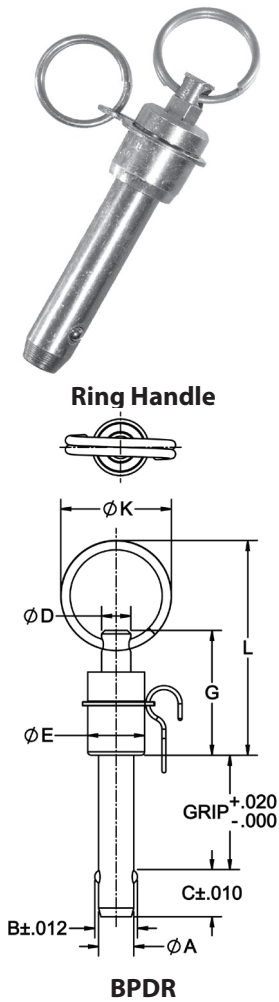

INCH

PART NO.	A DIA		B	C	D DIA	E DIA	F	G	H	J	K DIA	L	M							
	NOMINAL	ACTUAL																		
CL-3-BPDx-x.xx-S	3/16 (#10)	.1885/.1870	.219	.385	.19	7/16	.86	1.02	1-1/2	1-1/4	1	1.86	.12							
CL-4-BPDx-x.xx-S	1/4	.2485/.2470	.290	.415	.25	1/2	.86	1.06	1-15/16	1-7/16			1.86	.12						
CL-5-BPDx-x.xx-S	5/16	.3110/.3095	.375	.485										.31	5/8	.97	1.24	2-3/16	1-19/32	1.97
CL-6-BPDx-x.xx-S	3/8	.3735/.3720	.438	.565	11/16	.97	1.24	2-3/16	1-19/32	1.97			.15							
CL-7-BPDx-x.xx-S	7/16	.4360/.4345	.508	.635									.43							
CL-8-BPDx-x.xx-S	1/2	.4985/.4970	.592	.725	.56	15/16	1.13	1.43	2-7/16	1-3/4	2.44	.18								
CL-9-BPDx-x.xx-S	9/16	.5610/.5595	.666	.886								.56	1-1/8	1.29	1.59	2-25/32	2-3/16	2.62	.18	
CL-10-BPDx-x.xx-S	5/8	.6235/.6220	.750	.925															.56	1-1/4
CL-12-BPDx-x.xx-S	3/4	.7485/.7470	.886	1.075	.56	1-1/4	1.47	1.77	2-25/32	2-3/16	2.79	.29								
CL-14-BPDx-x.xx-S	7/8	.8735/.8720	1.044																.28	
CL-16-BPDx-x.xx-S	1	.9985/.9970	1.217									.30								

METRIC

BASIC PART NO.	A DIA (mm)		B (mm)	C (mm)	D DIA (mm)	E DIA (mm)	G (mm)	K DIA (mm)	L (mm)	M (mm)
	NOMINAL	ACTUAL								
CLM-5-BPDx-xx-S	5	4.96 / 4.92	5.38	9.78	5	11	26	25.5	47	3
CLM-6-BPDx-xx-S	6	5.96 / 5.92	7.06	9.78	5	11	26	25.5	47	3
CLM-8-BPDx-xx-S	8	7.96 / 7.92	9.42	10.54	6.5	12.5	26	25.5	47	3.5
CLM-10-BPDx-xx-S	10	9.96 / 9.92	11.91	12.32	6.5	16	27	25.5	47	4
CLM-12-BPDx-xx-S	12	11.96 / 11.92	14.40	14.35	8	17.5	31.5	25.5	50	4.5
CLM-16-BPDx-xx-S	16	15.96 / 15.92	19.00	18.42	11	20.5	36.5	33.5	62	6.5
CLM-20-BPDx-xx-S	20	19.96 / 19.92	24.08	23.50	14	28.5	40.5	33.5	66.5	7

DOUBLE-ACTING BALL LOCK PINS

SHANK: 17-4PH STAINLESS STEEL, HEAT TREATED RC 40 MIN, PASSIVATED
 SPINDLE: 17-4PH STAINLESS STEEL, PASSIVATED
 HEAD, BUTTON & HANDLE: 300-SERIES STAINLESS STEEL, PASSIVATED
 SPRING & RING: 302 STAINLESS STEEL
 BALLS: 440C STAINLESS STEEL

1

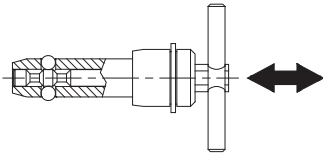

Similar to a single-acting pin, except the center spindle has two grooves instead of one, to release the ball by either pushing or pulling. Pushing on the handle releases the balls and inserts the pin in one motion. Pulling on the handle releases the balls and removes the pin in one motion. Available in steel or stainless steel. Choice of three handle styles: T, L, and Ring. Standard shank diameters from 3/16 to 1" (5 to 20mm in metric). Any grip length up to 6" (150mm in metric) is available as a standard, at no extra charge. Available in stainless steel only.

Ordering Example (INCH):

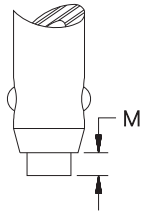
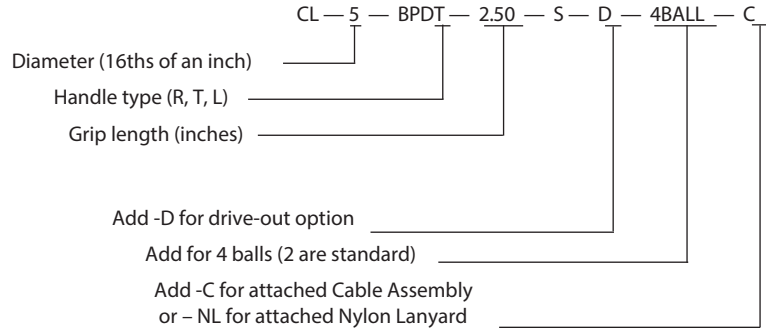

Drive-Out Option

Double-acting Ball Lock Pins are available with a "drive-out" option, where the center spindle extends slightly beyond the shank end (see M dimension). This allows removing a pin under slight shear load by tapping the shank end with a hammer (releasing the balls at the same time).

Ordering Example (METRIC):

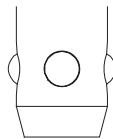
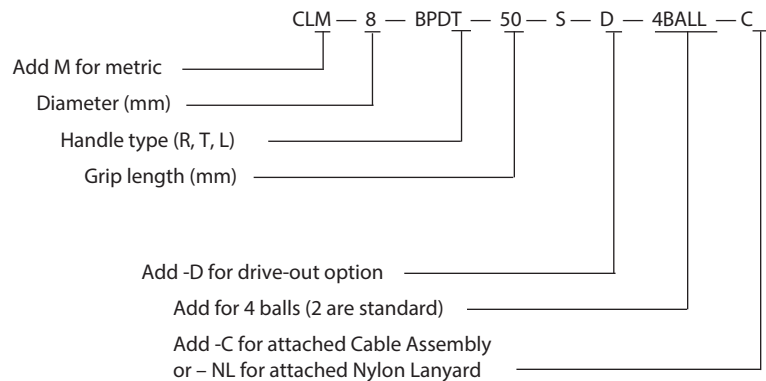

4-Ball Option

Ball Lock Pins are optionally available in stainless steel instead of alloy steel for greater corrosion resistance. Pins are also available with four balls instead of two, as specials, for additional pull-out strength and more distributed ball-contact force.



Optional Cable

The optional attached Cable Assembly (-C) is 12" long (part no. CL-82-KA-12.0 if ordered separately), while the optional attached Nylon Lanyard (-NL) is 10" long (part no. CL-1-NL-10 if ordered separately). Both have an eyelet at the free end for a #10 or M5 attachment screw.

LIFTING PINS

SHANK: 17-4PH STAINLESS STEEL, HEAT TREATED RC 40 MIN; SPINDLE: 17-4PH STAINLESS STEEL;
 SHACKLE: FORGED STEEL PER RR-C271, ZINC PLATED CLEAR CHROMATE; BUTTON: 303 STAINLESS STEEL;
 CAP SCREW, NUT, AND BUSHING: 300-SERIES STAINLESS STEEL; SPRING: 302 STAINLESS STEEL; BALLS: 440C STAINLESS STEEL

1



Stainless Steel

A single-acting ball lock pin with a solid, one-piece body and four balls for high tension loads. Sturdy forged shackle for heavy lifting. Shank diameters from 1/4 to 1" are available, in several standard lengths. INFO+: See safety precautions on page 74.

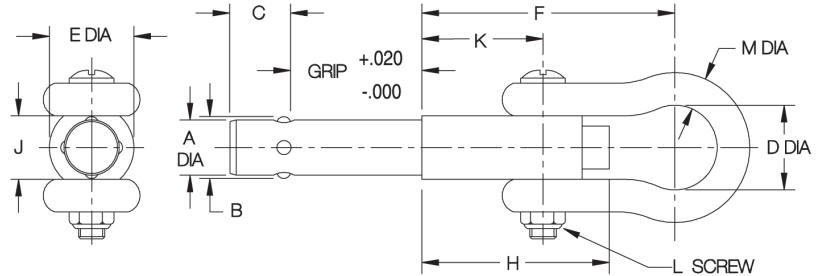

STAINLESS STEEL (INCH)

PART NO.	A DIA	GRIP	B	C	D DIA	E DIA	F	H	J	K	L	M DIA
CL-4-LFP-0.25-S	1/4 .2470/.2485	0.25	.287	.333	9/16	9/16	2.45	1.50	1/2	7/8	M6	3/16
CL-4-LFP-0.50-S		0.50										
CL-4-LFP-1.00-S		1.00										
CL-4-LFP-1.50-S		1.50										
CL-4-LFP-2.00-S	2.00											
CL-6-LFP-0.25-S	3/8 .3720/.3735	0.25	.438	.425	11/16	3/4	2.85	1.60	9/16	15/16	5/16-18	1/4
CL-6-LFP-0.50-S		0.50										
CL-6-LFP-1.00-S		1.00										
CL-6-LFP-1.50-S		1.50										
CL-6-LFP-2.00-S	2.00											
CL-6-LFP-3.00-S	3.00											
CL-8-LFP-0.50-S	1/2 .4970/.4985	0.50	.593	.519	13/16	13/16	3.15	1.80	11/16	1	3/8-16	5/16
CL-8-LFP-1.00-S		1.00										
CL-8-LFP-1.50-S		1.50										
CL-8-LFP-2.00-S		2.00										
CL-8-LFP-3.00-S	3.00											
CL-12-LFP-0.50-S	3/4 .7470/.7485	0.50	.887	.707	1-1/8	1-1/8	4.05	2.20	15/16	1-1/4	1/2-13	7/16
CL-12-LFP-1.00-S		1.00										
CL-12-LFP-2.00-S		2.00										
CL-12-LFP-3.00-S		3.00										
CL-16-LFP-0.50-S	1 .9970/.9985	0.50	1.217	.957	1-1/4	1-3/8	4.55	2.75	1-1/8	1-1/2	M8	1/2
CL-16-LFP-1.00-S		1.00										
CL-16-LFP-2.00-S		2.00										

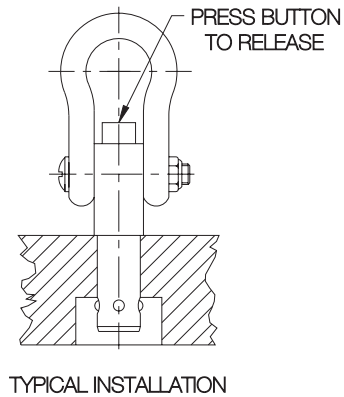

TYPICAL INSTALLATION

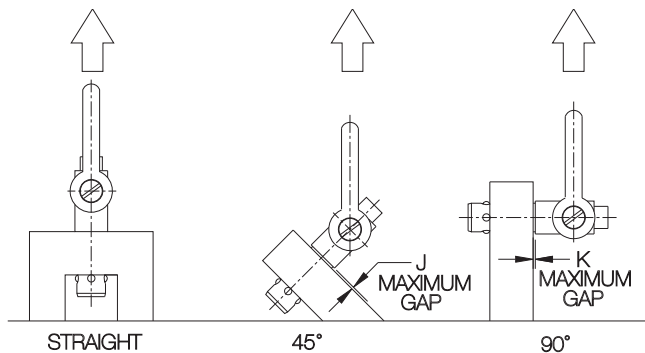

TECHNICAL DATA

PART NO.	LOAD CAPACITY (LBS)*			J (45°)	K (90°)	RECOMMENDED HOLE DIA	
	STRAIGHT	45°	90°			MAX	MIN
CL-4-LFP-x.xx-S	210	170	120	.031	.037	.254	.250
CL-6-LFP-x.xx-S	520	520	350	.036	.042	.379	.375
CL-8-LFP-x.xx-S	980	900	770			.505	.500
CL-12-LFP-x.xx-S	2200	2200	2000	.041	.047	.757	.750
CL-16-LFP-x.xx-S	2900	2800	2500	.046	.052	1.010	1.000

* 5:1 Safety factor, based on the average failing load of test specimens. See above for allowable installation-hole tolerances. Straight pull capacity assumes pin is installed in a hardened tool steel plate or bushing. Use standard lifting hook so that button is not depressed while lifting.

LIFTING PINS

SHANK: ALLOY STEEL, HEAT TREATED, MANGANESE PHOSPHATE FINISH; SPINDLE: ALLOY STEEL, MANGANESE PHOSPHATE FINISH;
SHACKLE: ALLOY STEEL, HEAT TREATED, MANGANESE PHOSPHATE FINISH; BUTTON: ALUMINUM ALLOY, RED ANODIZED;
CAP SCREW, NUT, AND BUSHING: STEEL, ZINC PLATED CLEAR CHROMATE; SPRING: STAINLESS STEEL; BALLS: 440C STAINLESS STEEL

1



Alloy Steel

A single-acting ball lock pin with a solid, one-piece body and four balls for high tension loads. Positive locking until released by pushing the button. Sturdy forged shackle for heavy lifting. Manganese phosphate finish provides excellent lubricity and corrosion resistance. INFO+: See safety precautions on page 74.

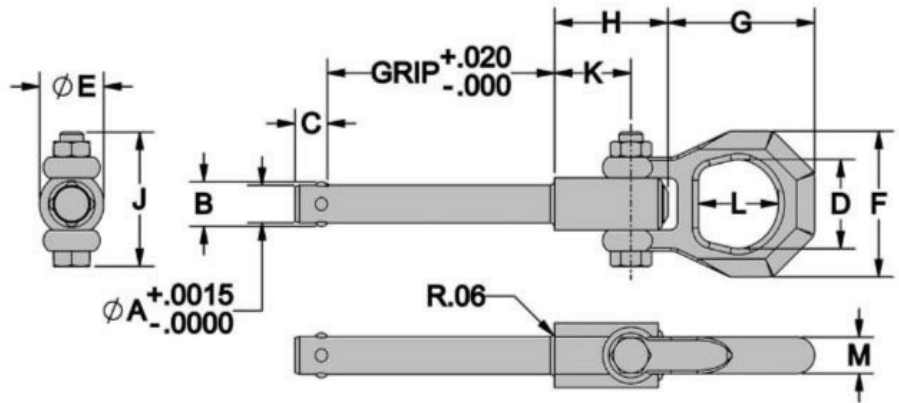

ALLOY STEEL (INCH)

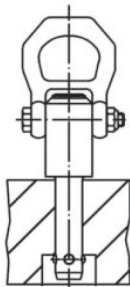

PART NO.	A DIA		GRIP LENGTH	B	C	D	E DIA	F	G	H	J	K	L	M
	NOMINAL	ACTUAL												
CL-4-LFPM-0.50	1/4	.2470/.2485	0.50	.29	.33									
CL-4-LFPM-1.00			1.00											
CL-4-LFPM-1.50			1.50											
CL-6-LFPM-0.50	3/8	.3720/.3735	0.50	.44	.40	1.18	0.85	1.93	1.94	1.50	2.06	1.01	1.06	0.37
CL-6-LFPM-1.00			1.00											
CL-6-LFPM-1.50			1.50											
CL-6-LFPM-2.00			2.00											
CL-8-LFPM-1.50	1/2	.4970/.4985	1.50	.59	.44									
CL-8-LFPM-2.00			2.00											
CL-8-LFPM-3.00			3.00											

TECHNICAL DATA

PART NO.	LOAD CAPACITY (LBS)*			X		RECOMMENDED HOLE DIA	
	STRAIGHT	45°	90°	MIN	MAX	MAX	MIN
CL-4-LFPM-X.XX	210	170	110	.06	.20	.254	.250
CL-6-LFPM-X.XX	600	540	470		.39	.379	.375
CL-8-LFPM-X.XX	790	630	630		.59	.505	.500

* 5:1 Safety factor, based on the average failing load of test specimens. See above for allowable installation-hole tolerances. Straight pull capacity assumes pin is installed in a hardened tool steel plate or bushing. Use standard lifting hook so that button is not depressed while lifting.

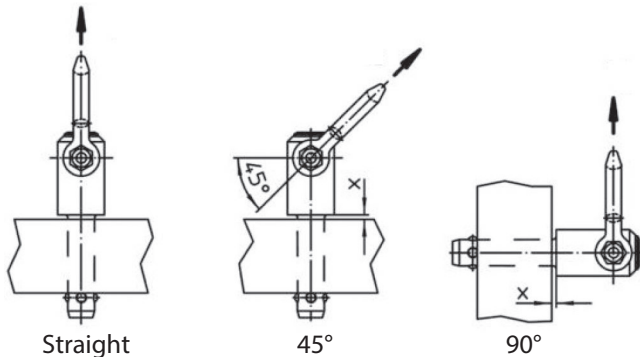

BALL LOCK RECEIVER CAPS

300+ SERIES STAINLESS STEEL, PASSIVATED

1



Receiver Caps are ideal for securing Ball Lock Pins used in clevis applications, especially when the through-hole has excess clearance. The Receiver Cap's inside diameter fits the Ball Lock Pin exactly, and is stepped to provide a perfect locking surface for the balls. Available to fit Ball Lock Pin diameters from 3/16 to 1" (5 to 20mm in metric). Made of 300-series stainless steel. Please note, using a Receiver Cap reduces the Ball Lock Pin's effective grip length slightly (see D dimension).

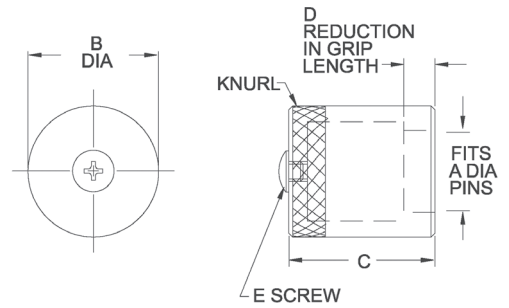
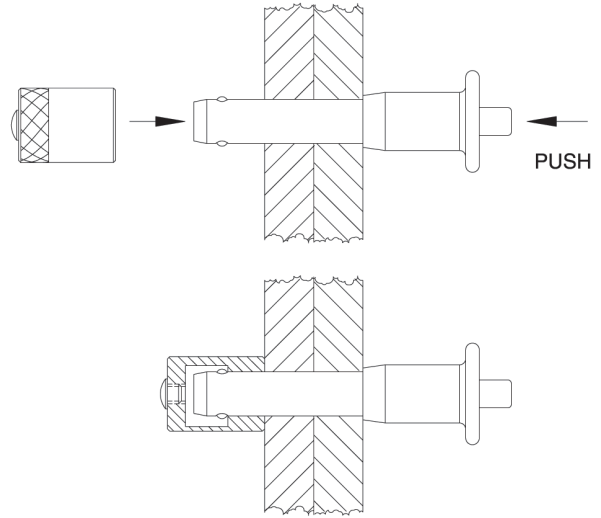

Receiver Caps are tapped to allow fastening the eyelet end of a standard Ball Lock Pin Cable Assembly (12" long) or Nylon Lanyard (10" long), and include a fastening screw.

INCH

PART NO.	A DIA	B DIA	C	D	E
CL-3-BLR-S	3/16 (#10)	.50	.72	1/4	#10-32
CL-4-BLR-S	1/4	.50	.81		
CL-5-BLR-S	5/16	.63	.81		
CL-6-BLR-S	3/8	.75	1.16	1/2	
CL-7-BLR-S	7/16	.75	1.16		
CL-8-BLR-S	1/2	.88	1.25		
CL-9-BLR-S	9/16	.88	1.25		
CL-10-BLR-S	5/8	1.00	1.31		
CL-12-BLR-S	3/5	1.25	1.45		
CL-14-BLR-S	7/8	1.50	1.48		
CL-16-BLR-S	1	1.50	1.69		

METRIC

PART NO.	A DIA (mm)	B DIA (mm)	C (mm)	D (mm)	E THREAD
CLM-5-BLR-S	5	12.5	24	10	M5
CLM-6-BLR-S	6	12.5	24	10	M5
CLM-8-BLR-S	8	16	25	10	M5
CLM-10-BLR-S	10	19	26	10	M5
CLM-12-BLR-S	12	22	29	10	M5
CLM-16-BLR-S	16	25	32	10	M5
CLM-20-BLR-S	20	32	38	10	M5

DETENT PINS

SHANK & HEAD: 300-SERIES STAINLESS STEEL, PASSIVATED; SPRING & RING: 302 STAINLESS STEEL; BALLS: 440C STAINLESS STEEL

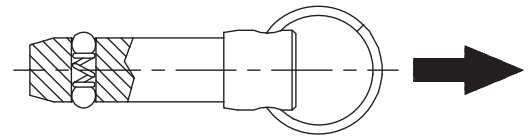

1

Solid alignment pin with spring-loaded locking balls (not positive locking like a Ball Lock Pin). Simply push pin to insert, and pull to remove. Available in steel or stainless steel. Standard shank diameters from 3/16 to 1" (6 to 20mm in metric). Note: 3/16-diameter pins have one ball, instead of two, due to their small size. Any grip length up to 6" (150mm in metric) is available as a standard, at no extra charge. Available from stock in many standard grip lengths, or quickly made to order in custom lengths and diameters.

Optional Cable

The optional attached Cable Assembly (-C) is 12" long (part no. CL-82-KA-12.0 if ordered separately), while the optional attached Nylon Lanyard (-NL) is 10" long (part no. CL-1-NL-10 if ordered separately). Both have an eyelet at the free end for a #10 or M5 attachment screw.

Ordering Example (INCH):

CL - 4 - DEP - 1.50 - S - C
 Diameter (16ths of an inch) | Grip length (inches) | Add -C for attached Cable Assembly or -NL for attached Nylon Lanyard

Ordering Example (Metric):

CLM - 6 - DEP - 50 - S - C
 Add M for metric | Diameter (mm) | Grip length (mm) | Add -C for attached Cable Assembly or -NL for attached Nylon Lanyard

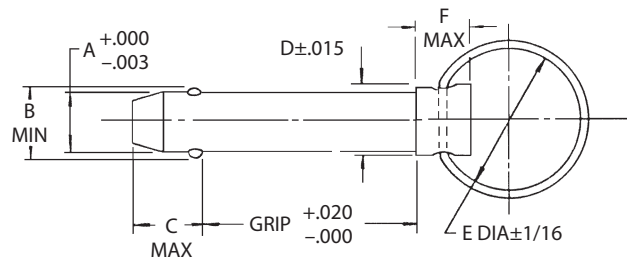

INCH

PART NO.	A DIA		B	C	D DIA	E DIA	F	STOCK GRIP LENGTH (INCHES)														
	NOMINAL	ACTUAL						0.50	0.75	1.00	1.25	1.50	1.75	2.00	2.25	2.50	3.00	3.50	4.00			
CL-3-DEP-x.xx-S	3/16(#10)	.1880	.217	.250	.375	1.00	.562	•	•	•	•	•	•	•	•	•	•	•	•	•	•	
CL-4-DEP-x.xx-S	1/4	.2480	.280	.344	•			•	•	•	•	•	•	•	•	•	•	•	•	•	•	•
CL-5-DEP-x.xx-S	5/16	.3105	.360	.359	.438			•	•	•	•	•	•	•	•	•	•	•	•	•	•	•
CL-6-DEP-x.xx-S	3/8	.3730	.430	.390	.500			•	•	•	•	•	•	•	•	•	•	•	•	•	•	•
CL-8-DEP-x.xx-S	1/2	.4980	.570	.516	.625			•	•	•	•	•	•	•	•	•	•	•	•	•	•	•
CL-10-DEP-x.xx-S	5/8	.6230	.720	.672	.750			•	•	•	•	•	•	•	•	•	•	•	•	•	•	•
CL-12-DEP-x.xx-S	3/4	.7480	.860	.750	.875			•	•	•	•	•	•	•	•	•	•	•	•	•	•	•
CL-16-DEP-x.xx-S	1	.9980	1.16	.984	1.125	•	•	•	•	•	•	•	•	•	•	•	•	•	•	•		

METRIC

PART NO.	A DIA		B	C	D DIA	E DIA	F	STOCK GRIP LENGTH (mm)						
	NOMINAL	ACTUAL						15	20	25	30	40	50	
CLM-6-DEP-x.xx-S	6mm	.2342	.266	.344	.375	1.00	.562	•	•			•	•	
CLM-8-DEP-x.xx-S	8mm	.3130	.363	.359	.438			•	•			•	•	
CLM-10-DEP-x.xx-S	10mm	.3917	.451	.390	.500			•	•			•	•	
CLM-12-DEP-x.xx-S	12mm	.4704	.540	.516	.563			•	•			•	•	

MARINE DETENT PINS

SHANK: 316 STAINLESS STEEL
 RING: 316 OR 300-SERIES STAINLESS STEEL
 SPRING & BALLS: 316 STAINLESS STEEL

Marine Detent Pins are made of 316 stainless steel for extra corrosion resistance. Economical quick-release alignment pin with a solid shank and spring-loaded locking balls. This type of Detent Pin has a ring instead of a solid shoulder, for applications where exact grip length is not important. Locking balls hold the pin in place by spring force (not positive locking like a Ball Lock Pin). Simply push the pin to insert, and pull to remove. Available in standard pin diameters from 3/16 to 1/2", in stainless steel only. Note: 3/16" pins have only one locking ball instead of two due to their small size. Available from stock in many standard grip lengths, with other grip lengths available as specials. Optionally available with an attached Cable Assembly (-C) or an attached Nylon Lanyard (-NL).

1



Ordering Example (INCH):

CL-4- MDP -1.50 -S - C

Diameter (16ths of an inch) ————
 Grip length (inches) ————
 Add -C for attached Cable Assembly
 or -NL for attached Nylon Lanyard

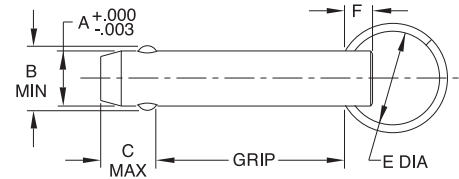

DIMENSIONS (INCH)

PART NO.	A DIA		B	C	E DIA	F DIA
	NOMINAL	ACTUAL				
CL-3-MDP-x.xx-S	3/16 (#10)	.1880	.200	.329	1.00	.25
CL-4-MDP-x.xx-S	1/4	.2480	.280	.344		
CL-5-MDP-x.xx-S	5/16	.3105	.360	.359		
CL-6-MDP-x.xx-S	3/8	.3730	.430	.390		
CL-8-MDP-x.xx-S	1/2	.4980	.570	.516		

STANDARD STOCK GRIP LENGTHS (INCH)

PART NO.	NOMINAL SHANK DIA	GRIP LENGTH (INCHES)												
		0.50	0.75	1.00	1.25	1.50	1.75	2.00	2.25	2.50	3.00	3.50	4.00	
CL-3-MDP-x.xx-S	3/16 (#10)	X	X	X	X	X	X	X	X	X				
CL-4-MDP-x.xx-S	1/4	X	X	X	X	X	X	X	X	X	X			
CL-5-MDP-x.xx-S	5/16		X	X	X	X	X	X		X	X	X	X	
CL-6-MDP-x.xx-S	3/8		X	X	X	X	X	X	X	X	X	X	X	X
CL-8-MDP-x.xx-S	1/2			X	X	X	X	X		X	X	X	X	X

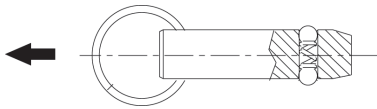

ECONOMY DETENT PINS

SHANK: MILD STEEL, ZINC PLATED CLEAR CHROMATE
 RING: STEEL SPRING WIRE, ZINC PLATED CLEAR CHROMATE
 SPRING & BALLS: STEEL

Economical quick-release alignment pin with a solid steel shank and one spring-loaded locking ball. This type of Detent Pin has a ring instead of a solid shoulder, for applications where exact grip length is not important. Locking ball holds the pin in place by spring force (not positive locking like a Ball Lock Pin). Simply push the pin to insert, and pull to remove. Available in standard pin diameters 3/16", 1/4", 5/16", and 1/2", in the standard grip lengths listed below. Optionally available with an attached Cable Assembly (-C) or an attached Nylon Lanyard (-NL). For other diameters and grip lengths, see above for Marine Detent Pins (the stainless steel version of this pin).



INCH

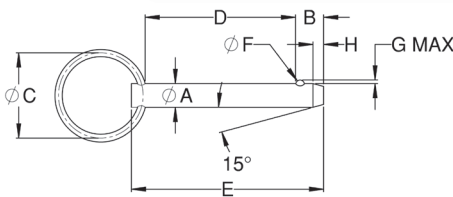

PART NO.	A DIA		B	C DIA	D GRIP LENGTH	E	F DIA	G	H
	NOMINAL	ACTUAL							
CL-3-EDP-1.00	3/16	.1855 / .1880	.23	7/8	1.00	1.37	3/32	.028	.08
CL-4-EDP-1.25	1/4	.2480 / .2505	.28	1	1.25	1.67	1/8	.038	.09
CL-4-EDP-1.50					1.50	1.92			
CL-5-EDP-1.00	5/16	.3105 / .3130	.34	1	1.00	1.53	5/32	.047	.13
CL-8-EDP-1.50	1/2	.4980 / .5005	.52	1-1/4	1.50	2.25	1/4	.075	.17
CL-8-EDP-2.00					2.00	2.75			

THREADED DETENT PINS

SHANK: 300-SERIES STAINLESS STEEL
 SPRING: 17-7PH OR 302 STAINLESS STEEL
 BALLS: 440C STAINLESS STEEL

1



Threaded Detent Pins are solid alignment pins with a ground shank and a threaded end for a knob handle. Two locking balls hold the pin in place by spring force. Simply push to insert, and pull to remove. The threaded end accepts virtually any type of knob handle (order separately — available in steel, stainless steel, and several different plastics). Knob handles can be permanently secured with thread-locking adhesive if desired. Threaded Detent Pins are available in stainless steel only. Standard shank diameters from 3/16 to 1/2" (6 to 10mm in metric), each in a choice of many standard grip lengths. Note: 3/16-diameter pins have only one locking ball instead of two due to their small size. Available from stock only in the standard grip lengths listed (other grip lengths available as specials).

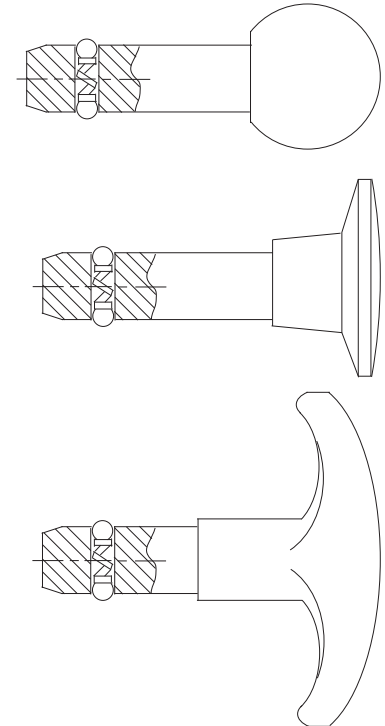

INFO+: For a wide selection of knob handles to fit these Threaded Detent Pins, see pages 152-159.

INCH

PART NO.	A DIA		GRIP LENGTH	B	C	D	F	
	NOMINAL	ACTUAL						
CL-3-TDP-0.50-S	3/16(#10)	.1880	.50	.200	.250	#8-32	1/4	
CL-3-TDP-0.75-S			.75					
CL-3-TDP-1.00-S			1.00					
CL-3-TDP-1.25-S			1.25					
CL-3-TDP-1.50-S			1.50					
CL-3-TDP-1.75-S			1.75					
CL-3-TDP-2.00-S	2.00	1/4						
CL-4-TDP-0.50-S	1/4		.2480	0.50	.280	.344	#10-32	
CL-4-TDP-0.75-S				0.75				
CL-4-TDP-1.00-S				1.00				
CL-4-TDP-1.25-S				1.25				
CL-4-TDP-1.50-S				1.50				
CL-4-TDP-1.75-S		1.75						
CL-4-TDP-2.00-S	2.00	3/8						
CL-4-TDP-2.50-S	2.50		1/4-20					
CL-4-TDP-3.00-S	3.00							
CL-5-TDP-0.75-S	5/16			.3105	0.75	.360	.359	1/4-20
CL-5-TDP-1.00-S					1.00			
CL-5-TDP-1.25-S					1.25			
CL-5-TDP-1.50-S		1.50						
CL-5-TDP-1.75-S		1.75						
CL-5-TDP-2.00-S		2.00						
CL-5-TDP-2.50-S	2.50	3/8						
CL-5-TDP-3.00-S	3.00		1/4-20					
CL-6-TDP-0.75-S	3/8			.3730	0.75	.430	.390	1/4-20
CL-6-TDP-1.00-S					1.00			
CL-6-TDP-1.25-S					1.25			
CL-6-TDP-1.50-S					1.50			
CL-6-TDP-1.75-S		1.75						
CL-6-TDP-2.00-S		2.00						
CL-6-TDP-2.50-S	2.50	1/2						
CL-6-TDP-3.00-S	3.00		3/8-16					
CL-6-TDP-3.50-S	3.50							
CL-6-TDP-4.00-S	4.00							
CL-8-TDP-1.00-S	1/2			.4980	1.00	.570	.516	3/8-16
CL-8-TDP-1.50-S					1.50			
CL-8-TDP-2.00-S		2.00						
CL-8-TDP-2.50-S		2.50						
CL-8-TDP-3.00-S		3.00						
CL-8-TDP-3.50-S		3.50						
CL-8-TDP-4.00-S	4.00							

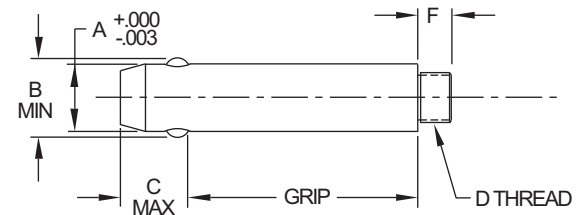

METRIC

PART NO.	A DIA (mm)		GRIP LENGTH (mm)	B (mm)	C (mm)	D THREAD	F (mm)
	NOMINAL	ACTUAL					
CLM-6-TDP-15-S	6	5.95	15	6.75	8.74	M5	6
CLM-6-TDP-20-S	6	5.95	20	6.75	8.74	M5	6
CLM-6-TDP-25-S	6	5.95	25	6.75	8.74	M5	6
CLM-6-TDP-30-S	6	5.95	30	6.75	8.74	M5	6
CLM-6-TDP-40-S	6	5.95	40	6.75	8.74	M5	6
CLM-6-TDP-50-S	6	5.95	50	6.75	8.74	M5	6
CLM-8-TDP-20-S	8	7.95	20	9.22	9.11	M6	10
CLM-8-TDP-25-S	8	7.95	25	9.22	9.11	M6	10
CLM-8-TDP-30-S	8	7.95	30	9.22	9.11	M6	10
CLM-8-TDP-40-S	8	7.95	40	9.22	9.11	M6	10
CLM-8-TDP-50-S	8	7.95	50	9.22	9.11	M6	10
CLM-10-TDP-20-S	10	9.95	20	11.45	9.90	M8	10
CLM-10-TDP-25-S	10	9.95	25	11.45	9.90	M8	10
CLM-10-TDP-30-S	10	9.95	30	11.45	9.90	M8	10
CLM-10-TDP-40-S	10	9.95	40	11.45	9.90	M8	10
CLM-10-TDP-50-S	10	9.95	50	11.45	9.90	M8	10

EXPANDING PINS

SPLIT BUSHINGS, MALE SEGMENTS, & SPACERS: 17-4PH STAINLESS STEEL, RC 40 MIN, PASSIVATED, DRY FILM LUBE
 CENTER SPINDLE: 17-4PH STAINLESS STEEL, RC 36-40, PASSIVATED, DRY FILM LUBE
 BARREL NUT & WASHER: 17-4PH STAINLESS STEEL, PASSIVATED, DRY FILM LUBE
 HANDLE: ALUMINUM ALLOY, POWDER COATED

Precision alignment pin that expands up to .006 inches to tighten up hole clearance. The pin is an assembly of female split bushings separated by male segments, on a center spindle, that expands when drawn together. This assembly provides excellent shear strength, comparable to a solid pin. Diameters from 1/4 to 3/4" are available in several standard lengths. Pins can be installed in through holes or blind holes. **INFO+**: Also see page 65, for hex-head type.

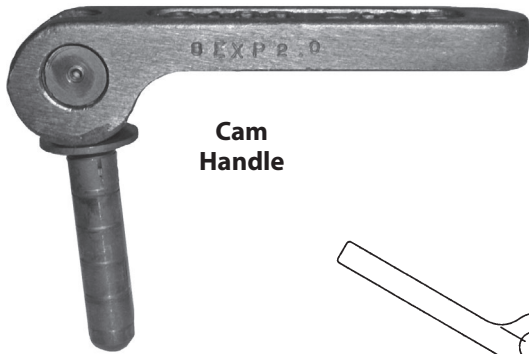

Cam Handle

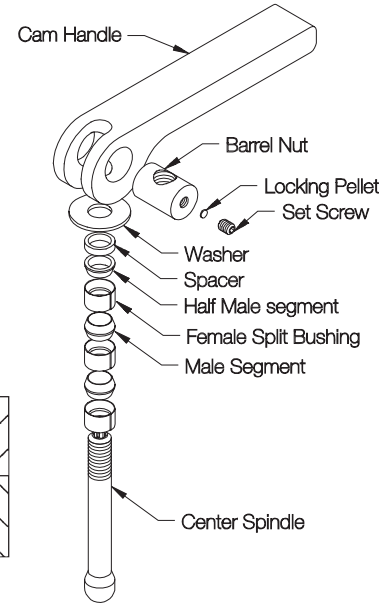
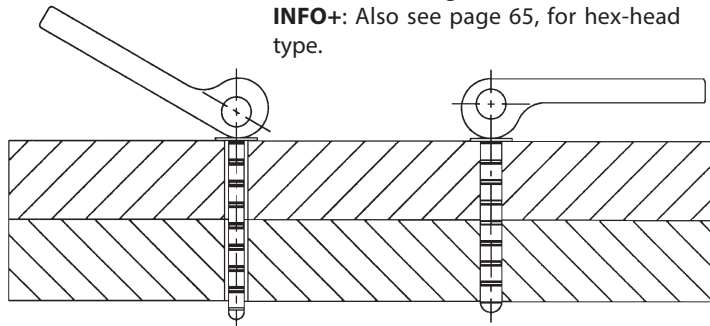

Moving the cam handle expands pin diameter up to .006 inches, to take up slack and secure the pin in place. If additional adjustment is required, remove set screw and turn the cam handle.

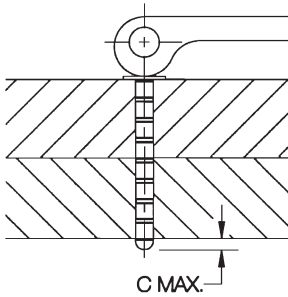

Important: Install so that all expanding bushings are contained in the installation hole.

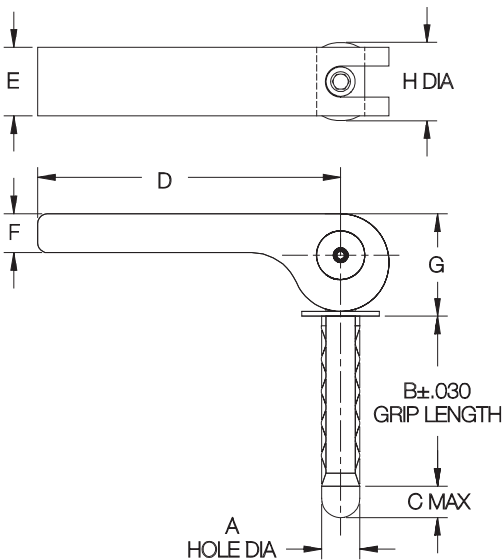

CAM HANDLE

PART NO.	A DIA			B	C	D	E	F	G	H DIA	DOUBLE-SHEAR STRENGTH (LBS)*
	NOMINAL	MIN	MAX								
CL-4-EXP-0.50	1/4	.250	.254	.50	1/4	2-3/8	1/2	5/16	.81	5/8	4,000
CL-4-EXP-0.75				.75							
CL-4-EXP-1.00				1.00							
CL-4-EXP-1.50				1.50							
CL-4-EXP-2.00				2.00							
CL-4-EXP-3.00	3.00										
CL-5-EXP-1.00	5/16	.312	.317	1.00	5/16	2-3/8	1	1/2	1.12	1	6,300
CL-5-EXP-2.00				2.00							
CL-5-EXP-3.00				3.00							
CL-6-EXP-1.00	3/8	.375	.380	1.00	3/8	4-1/2	1	1/2	1.12	1	9,000
CL-6-EXP-1.50				1.50							
CL-6-EXP-2.00				2.00							
CL-6-EXP-3.00	3.00										
CL-8-EXP-0.50	1/2	.500	.505	.50	1/2	4-1/2	1	1/2	1.12	1	16,100
CL-8-EXP-1.00				1.00							
CL-8-EXP-1.50				1.50							
CL-8-EXP-2.00				2.00							
CL-8-EXP-3.00				3.00							
CL-10-EXP-1.00	5/8	.625	.630	1.00	5/8	4-1/2	1	1/2	1.31	1	25,100
CL-10-EXP-1.50				1.50							
CL-10-EXP-2.00				2.00							
CL-10-EXP-3.00				3.00							
CL-12-EXP-2.00	3/4	.750	.757	2.00	3/4	6	1-1/4	3/4	2.09	1-1/4	36,200
CL-12-EXP-3.00				3.00							
CL-12-EXP-4.00				4.00							

* 2:1 Safety Factor

EXPANDING PINS

SPLIT BUSHINGS, MALE SEGMENTS, & SPACERS: 17-4PH STAINLESS STEEL, RC 40 MIN, PASSIVATED, DRY FILM LUBE
 CENTER SPINDLE: 17-4PH STAINLESS STEEL, RC 36-40, PASSIVATED, DRY FILM LUBE
 WASHER: 17-4PH STAINLESS STEEL, PASSIVATED, DRY FILM LUBE
 HEX NUT: 17-4PH STAINLESS STEEL, WITH LOCKING ELEMENT

1



Hex Head

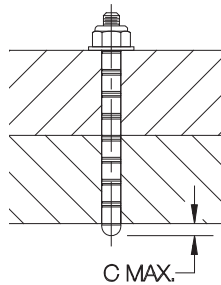

Important: Install pin so that all split bushings are contained in the installation hole.

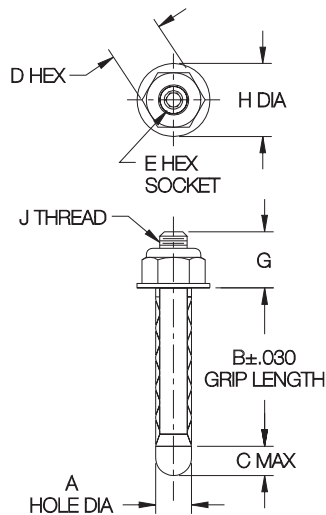

Precision alignment pin that expands up to .006 inches to tighten up hole clearance. The pin is an assembly of female split bushings separated by male segments, on a center spindle, that expands when drawn together. This assembly provides excellent shear strength, comparable to a solid pin. Diameters from 1/4 to 3/4" are available in several standard lengths. Pins can be installed in through holes or blind holes. **INFO+**: Also see page 64, for cam-handle type.

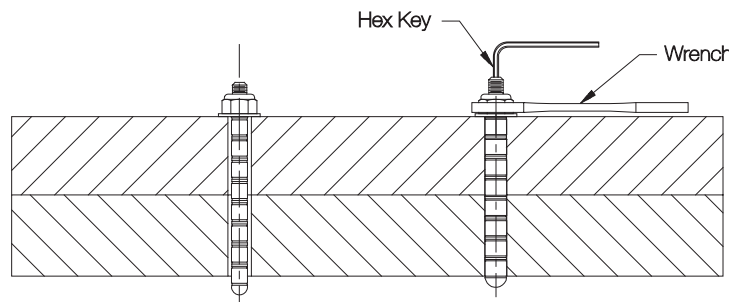

Tightening the hex nut with a wrench expands pin diameter up to .006 inches, to take up slack and secure the pin in place. Hold center spindle stationary with a hex key while tightening.

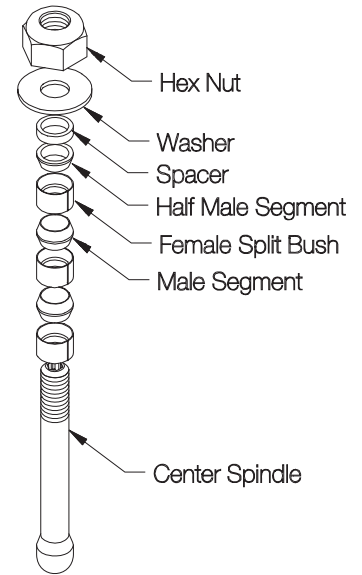

HEX HEAD

PART NO.	A DIA			B	C	D	E	G	H DIA	J	DOUBLE-SHEAR STRENGTH (LBS)*	INSTALLATION TORQUE (FT-LBS)
	NOMINAL	MIN	MAX									
CL-4-EXPH-0.50	1/4	.250	.254	.50	1/4	3/8	3/32	.39	.67	#10-32	4,000	3
CL-4-EXPH-0.75				.75								
CL-4-EXPH-1.00				1.00								
CL-4-EXPH-1.50				1.50								
CL-4-EXPH-2.00				2.00								
CL-4-EXPH-3.00	3.00											
CL-5-EXPH-1.00	5/16	.312	.317	1.00	5/16	3/8	3/32	.40	.67	#10-32	6,300	3
CL-5-EXPH-2.00				2.00								
CL-5-EXPH-3.00				3.00								
CL-6-EXPH-1.00	3/8	.375	.380	1.00	3/8	7/16	1/8	.49	.67	1/4-28	9,000	7.5
CL-6-EXPH-1.50				1.50								
CL-6-EXPH-2.00				2.00								
CL-6-EXPH-3.00	3.00											
CL-8-EXPH-0.50	1/2	.500	.505	.50	1/2	9/16	3/16	.71	.92	3/8-24	16,100	29
CL-8-EXPH-1.00				1.00								
CL-8-EXPH-1.50				1.50								
CL-8-EXPH-2.00				2.00								
CL-8-EXPH-3.00	3.00											
CL-10-EXPH-1.00	5/8	.625	.630	1.00	5/8	3/4	1/4	.90	1.22	1/2-20	25,100	83
CL-10-EXPH-1.50				1.50								
CL-10-EXPH-2.00				2.00								
CL-10-EXPH-3.00	3.00											
CL-12-EXPH-2.00	3/4	.750	.757	2.00	3/4	7/8	1/4	1.02	1.35	9/16-18	36,200	121
CL-12-EXPH-3.00				3.00								
CL-12-EXPH-4.00				4.00								

* 2:1 Safety Factor

CABLE ASSEMBLIES

INFO+: SEE PAGES 67-68 FOR MATERIAL SPECIFICATIONS

1



Cable Assemblies are ideal for attaching removable tooling components. High-strength stranded wire cable with a green nylon coating. These versatile attachment cables are available with various loops, Cable Rings, Terminals, and Cable Tabs.

Cable Assemblies are available in four cable sizes, in steel or stainless steel (#1 cable is only available in stainless steel). Stainless Cable Assemblies with Cable Rings are furnished with stainless Cable Rings. Minimum assembly length is 3.0". Length tolerance is held to $\pm 1/4"$ up to 24" long. **INFO+**: See page 69-70 for dimensions and specifications of Ferrules, Cable Rings, Terminals, and Cable Tabs. Note: These Cable Assemblies should not be used for lifting and other high-tension applications.

To order Cable Assemblies with an uncrimped ferrule (for installation), add a suffix to the part number shown on the next page:

- L for uncrimped left end
- R for uncrimped right end
- LR for both ends uncrimped

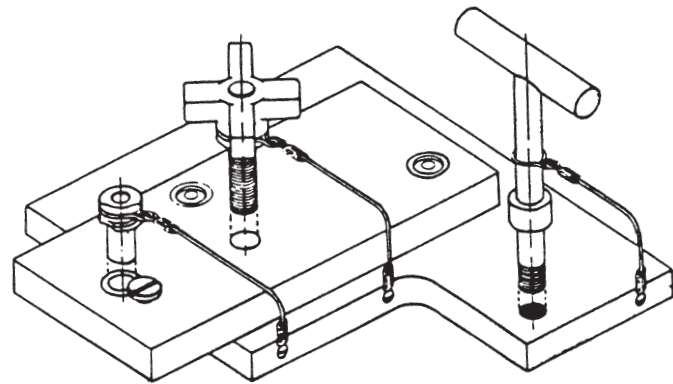

Cable Sizes

ASSEMBLY TYPE	LEFT END	RIGHT END	CABLE SIZES							
			1		2		3		4	
			STAINLESS	STEEL	STAINLESS	STEEL	STAINLESS	STEEL	STAINLESS	STEEL
1	LOOP	PLAIN	CL-11-KA	CL-12-KA	CL-12-SKA	CL-13-KA	CL-13-SKA	CL-14-KA	CL-14-SKA	
2	LOOP	LOOP	CL-21-KA	CL-22-KA	CL-22-SKA	CL-23-KA	CL-23-SKA	CL-24-KA	CL-24-SKA	
3	CABLE RING	PLAIN	CL-31-KA	CL-32-KA	CL-32-SKA	CL-33-KA	CL-33-SKA	--	--	
4	CABLE RING	LOOP	CL-41-KA	CL-42-KA	CL-42-SKA	CL-43-KA	CL-43-SKA	--	--	
5	CABLE RING	CABLE RING	CL-51-KA	CL-52-KA	CL-52-SKA	CL-53-KA	CL-53-SKA	--	--	
6	#5 TERMINAL	#5 TERMINAL	--	--	--	CL-63-KA	CL-63-SKA	--	--	
7	#10 TERMINAL	#10 TERMINAL	--	CL-72-KA	CL-72-SKA	CL-73-KA	CL-73-SKA	--	--	
8	#10 TERMINAL	LOOP	--	CL-82-KA	CL-82-SKA	--	--	--	--	
9	#10 TERMINAL	CABLE RING	--	CL-92-KA	CL-92-SKA	--	--	--	--	
10	#10 TERMINAL	PLAIN	--	CL-102-KA	CL-102-SKA	--	--	--	--	
11	TAB	TAB	CL-111-KA	CL-112-KA	CL-112-SKA	CL-113-KA	CL-113-SKA	--	--	
12	TAB	LOOP	CL-121-KA	CL-122-KA	CL-122-SKA	CL-123-KA	CL-123-SKA	--	--	
13	TAB	CABLE RING	CL-131-KA	CL-132-KA	CL-132-SKA	CL-133-KA	CL-133-SKA	--	--	
14	TAB	PLAIN	CL-141-KA	CL-142-KA	CL-142-SKA	CL-143-KA	CL-143-SKA	--	--	

CABLE ASSEMBLIES

1

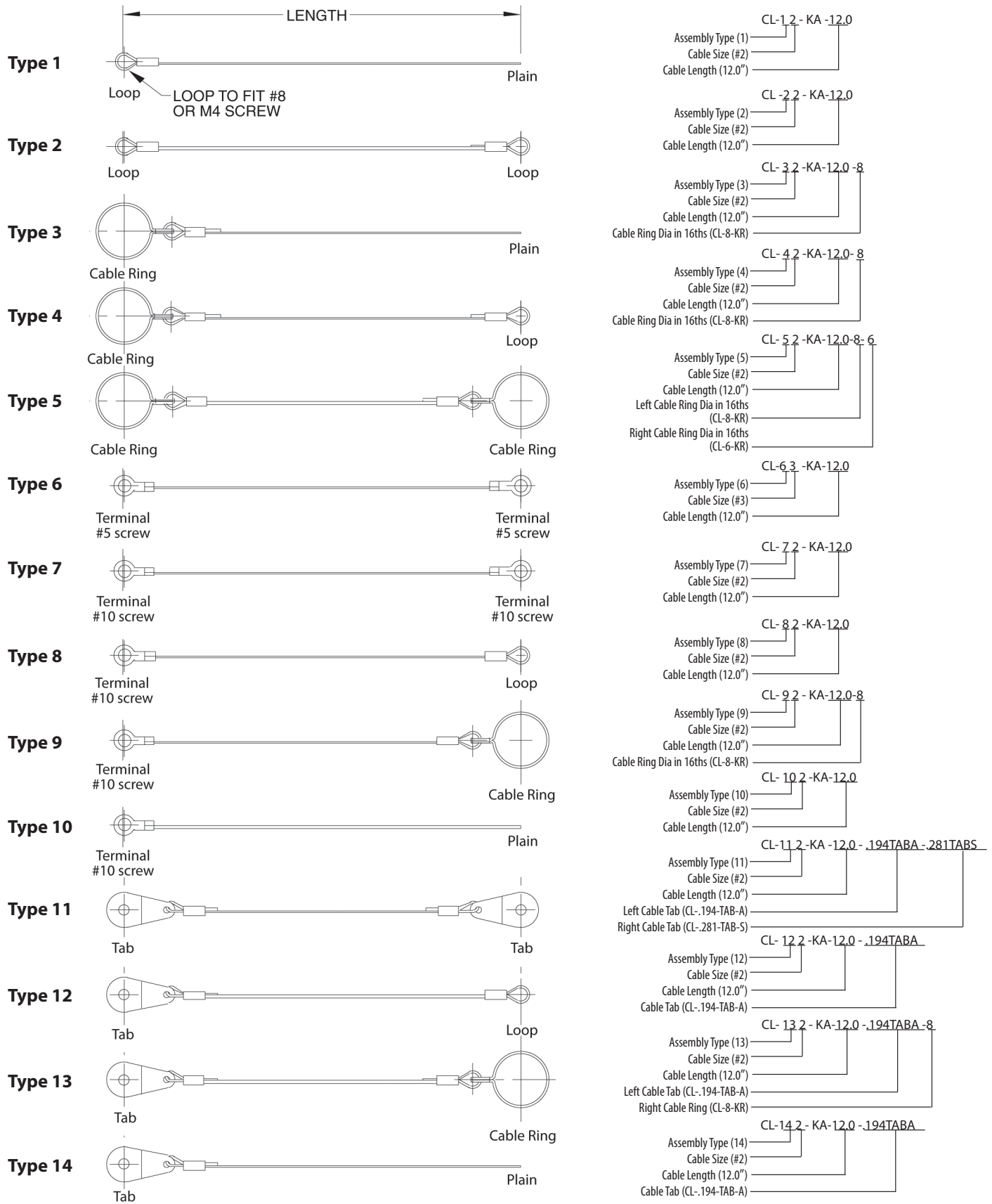

LOAD-RATED CABLE ASSEMBLIES

1

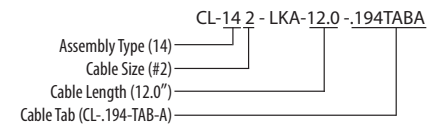
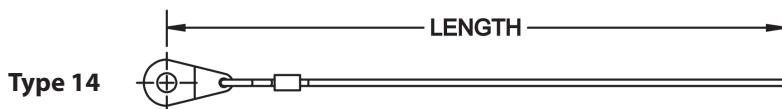
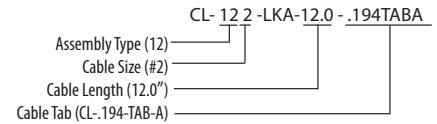
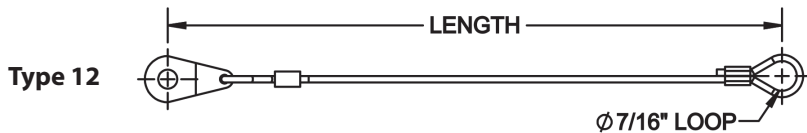
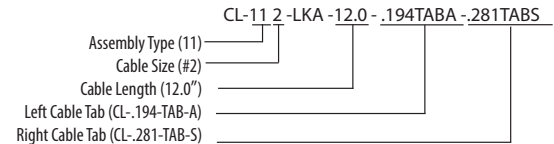
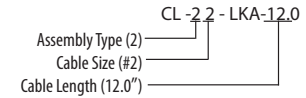
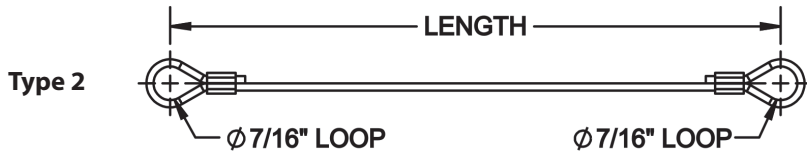
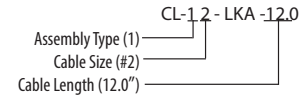
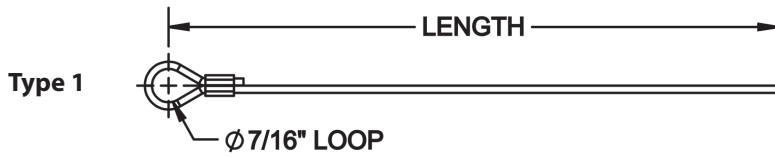

Load-Rated Cable Assemblies are ideal for applications with high pulling forces, where an extra-strong crimp is required. Please note that these cables are not designed for lifting applications, or where high impact forces occur. The high-strength stranded wire cable with a green nylon coating used for these assemblies is the same cable used for our standard cable assemblies. The difference is that Duplex Ferrules are used to achieve a stronger, precisely repeatable crimp. These ferrules require a specific crimping procedure, with a specific crimping tool and gauge to guarantee the assembly load rating. Load-Rated Cable Assemblies are available in two cable diameters, sizes #2 and #3.

BASIC PART NO.	CABLE SIZE (STEEL)	RATED LOAD (lbs)	ASSEMBLY TYPE	LEFT END	RIGHT END
CL-12-LKA	#2	100	1	LOOP	PLAIN
CL-22-LKA			2	LOOP	LOOP
CL-112-LKA			11	TAB	TAB
CL-122-LKA			12	TAB	LOOP
CL-142-LKA	#3	175	14	TAB	PLAIN
CL-13-LKA			1	LOOP	PLAIN
CL-23-LKA			2	LOOP	LOOP
CL-113-LKA			11	TAB	TAB
CL-123-LKA			12	TAB	LOOP
CL-143-LKA			14	TAB	PLAIN

CABLE

GALVANIZED STEEL OR STAINLESS STEEL, NYLON COATED (GREEN)



Cable Sizes

High-strength stranded wire cable with a green nylon coating. Choice of four cable diameters. Cable size 1 is made of stainless steel. Sizes 2, 3, and 4 are available in either galvanized steel or stainless steel. Cable is available in cut pieces (inch or mm), in bulk lengths, (feet or meters, 10 ft/ 3m minimum), or in 1000-ft rolls. Cut pieces are held to a $\pm 1/4"$ length tolerance up to 24" long. Examples:

CL-2-C-12.0 (Cut piece, #2 cable, 12" long)



CABLE SIZE	MATERIAL	PART NO.	LENGTH	D DIA		CONSTRUCTION	BREAKING STRENGTH (LBS)
				COATED	WIRE		
1	STAINLESS STEEL	CL-1-C-50FT	50 Feet	.044	.024	1x7	80
		CL-1-C-100FT	100 Feet				
		CL-1-C-250FT	250 Feet				
		CL-1-C-500FT	500 Feet				
		CL-1-C-1000FT	1000 Feet				
2	STEEL	CL-2-C-50FT	50 Feet	.062	.047	7x7	270
		CL-2-C-100FT	100 Feet				
		CL-2-C-250FT	250 Feet				
		CL-2-C-500FT	500 Feet				
		CL-2-C-1000FT	1000 Feet				
	STAINLESS STEEL	CL-2-SC-50FT	50 Feet				
		CL-2-SC-100FT	100 Feet				
		CL-2-SC-250FT	250 Feet				
		CL-2-SC-500FT	500 Feet				
		CL-2-SC-1000FT	1000 Feet				
3	STEEL	CL-3-C-50FT	50 Feet	.094	.062	7x7	480
		CL-3-C-100FT	100 Feet				
		CL-3-C-250FT	250 Feet				
		CL-3-C-500FT	500 Feet				
		CL-3-C-1000FT	1000 Feet				
	STAINLESS STEEL	CL-3-SC-50FT	50 Feet				
		CL-3-SC-100FT	100 Feet				
		CL-3-SC-250FT	250 Feet				
		CL-3-SC-500FT	500 Feet				
		CL-3-SC-1000FT	1000 Feet				
4	STEEL	CL-4-C-50FT	50 Feet	.187	.125	7x19	800
		CL-4-C-100FT	100 Feet				
		CL-4-C-250FT	250 Feet				
		CL-4-C-500FT	500 Feet				
		CL-4-C-1000FT	1000 Feet				
	STAINLESS STEEL	CL-4-SC-50FT	50 Feet				
		CL-4-SC-100FT	100 Feet				
		CL-4-SC-250FT	250 Feet				
		CL-4-SC-500FT	500 Feet				
		CL-4-SC-1000FT	1000 Feet				

FERRULES

COPPER, ELECTRO TIN PLATED

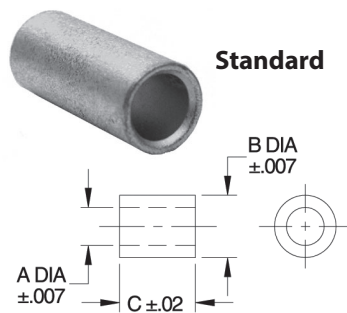

Standard

Ferrules are used to crimp a loop on the end of our nylon-coated cable. These standard round Ferrules are available in four diameters to fit our four standard cable sizes. An extra-long version is optionally available for #2 and #3 cable sizes, to allow double crimping. Ferrules may be slightly elliptical (partially crimped) at our option.

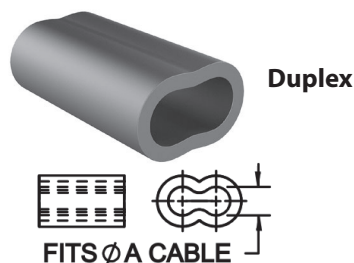

Duplex

Duplex Ferrules are used exclusively to make our Load-Rated Cable Assemblies. These ferrules require a specific crimping procedure, with a specific crimping tool and gauge to guarantee the assembly load rating. Duplex Ferrules are available in two sizes, to fit #2 and #3 cable.

STANDARD FERRULES

PART NO.	FITS CABLE	A	B	C
CL-1-F	SIZE 1	.094	.154	.315
CL-2-F	SIZE 2	.138	.213	.335
CL-4-F				.591
CL-3-F	SIZE 3	.185	.276	.374
CL-5-F	SIZE 4	.378	.520	.827
CL-6-F				1.260

DUPLEX FERRULES

PART NO.	FITS CABLE		B LENGTH
	SIZE	A DIA	
CL-2-DF	#2	.062	3/8
CL-3-DF	#3	.094	3/8

TERMINALS

COPPER, ELECTRO TIN PLATED



Terminals are for crimping on our nylon-coated cable, to allow attaching the end with a screw. Available for #2 and #3 cable.

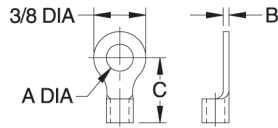

PART NO.	FITS CABLE	A		B	C
		A DIA	SCREW SIZE		
CL-.194-TERM-2	SIZE 2	.21	#10 (or M5)	.03	15/32
CL-.129-TERM	SIZE 3	.13	#5 (or M3)	.04	19/32
CL-.194-TERM		.21	#10 (or M5)	.04	

CABLE RINGS

SPRING STEEL WIRE, BLACK OXIDE FINISH



Cable Rings allow attaching Cable Assemblies to a diameter or radial groove. Can be used with cable sizes #1, #2, and #3. Available in steel or stainless steel.

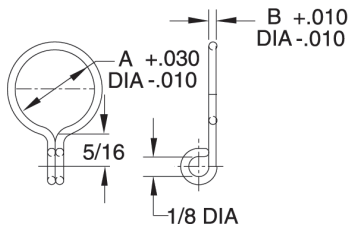

PART NO. STEEL	PART NO. STAINLESS	A DIA	B WIRE DIA	
			STEEL	STAINLESS
CL-2-KR	CL-2-SKR	1/8 (also 3mm)	.045	.062
CL-3-KR	CL-3-SKR	3/16 (also 4&5mm)		
CL-4-KR	CL-4-SKR	1/4 (also 6&7mm)		
CL-5-KR	CL-5-SKR	5/16 (also 8mm)		
CL-6-KR	CL-6-SKR	3/8 (also 9&10mm)		
CL-7-KR	CL-7-SKR	7/16 (also 11mm)		
CL-8-KR	CL-8-SKR	1/2 (also 12&13mm)		
CL-9-KR	CL-9-SKR	9/16 (also 14&15mm)		
CL-10-KR	CL-10-SKR	5/8 (also 16mm)		
CL-11-KR	CL-11-SKR	11/16 (also 17&18mm)		
CL-12-KR	CL-12-SKR	3/4 (also 19&20mm)		
CL-13-KR	CL-13-SKR	13/16 (also 21mm)		
CL-14-KR	CL-14-SKR	7/8 (also 22 or 23mm)		
CL-15-KR	CL-15-SKR	15/16 (also 24mm)		
CL-16-KR	CL-16-SKR	1 (also 25&26mm)		
CL-17-KR	CL-17-SKR	1-1/16 (also 27mm)		
CL-18-KR	CL-18-SKR	1-1/8 (also 28&29mm)		
CL-19-KR	CL-19-SKR	1-3/16 (also 30&31mm)		
CL-20-KR	CL-20-SKR	1-1/4 (also 32mm)		
CL-21-KR	CL-21-SKR	1-5/16 (also 33&34mm)		
CL-22-KR	CL-22-SKR	1-3/8 (also 35 mm)		
CL-23-KR	CL-23-SKR	1-7/16 (also 36&37mm)		
CL-24-KR	CL-24-SKR	1-1/2 (also 38mm)		

CABLE TABS

ALUMINUM: 6061 ALUMINUM ALLOY, CLEAR ANODIZED. STAINLESS: 300-SERIES STAINLESS STEEL, PASSIVATED



Teardrop



Rectangular

Cable Tabs attach to our nylon-coated cable, to allow attaching the end with a screw. Can be used with cable sizes #1, #2, and #3. Available in two shapes, teardrop and rectangular. Available in aluminum and stainless steel.

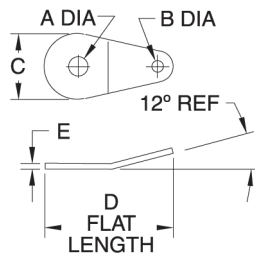

TEARDROP

PART NO. ALUMINUM	PART NO. STAINLESS STEEL	FITS CABLE	A		B DIA	C	D	E
			DIA	SCREW SIZE				
CL-.129-TAB-A	CL-.129-TAB-S	SIZES 1 TO 3	.13	#5 (or M3)	.13	.69	1.31	.06
CL-.194-TAB-A	CL-.194-TAB-S		.20	#10 (or M4)				
CL-.281-TAB-A	CL-.281-TAB-S		.28	1/4 (or M6)				

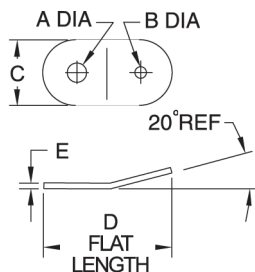

RECTANGULAR

PART NO. ALUMINUM	PART NO. STAINLESS STEEL	FITS CABLE	A		B DIA	C	D	E
			DIA	SCREW SIZE				
CL-.129-TABR-2-A	CL-.129-TABR-2-S	SIZES 1 TO 2	.13	#5 (or M3)	.09	1/2	1.14	.06
CL-.194-TABR-2-A	CL-.194-TABR-2-S		.20	#10 (or M4)				
CL-.281-TABR-2-A	CL-.281-TABR-2-S	SIZES 1 TO 3	.28	1/4 (or M6)	.19	1/2	1.14	.06
CL-.194-TABR-3-A	CL-.194-TABR-3-S		.20	#10 (or M4)				
CL-.281-TABR-3-A	CL-.281-TABR-3-S		.28	1/4 (or M6)				

CRIMPING TOOLS

STEEL WITH PLASTIC HANDGRIPS



Standard

Plier tool for manually crimping ferrules on our nylon-coated cable. Crimps ferrules on either #1 or #2 cable. Heavier cable sizes require power crimping and should be ordered finish-crimped from the factory whenever possible.

STANDARD CRIMPING TOOL

PART NO.	FOR CABLE	FOR FERRULES
CL-1-CT	SIZE 1	CL-1-F
	SIZE 2	CL-2-F
		CL-4-F

1

HEAVY-DUTY CRIMPING TOOLS

FORGED STEEL

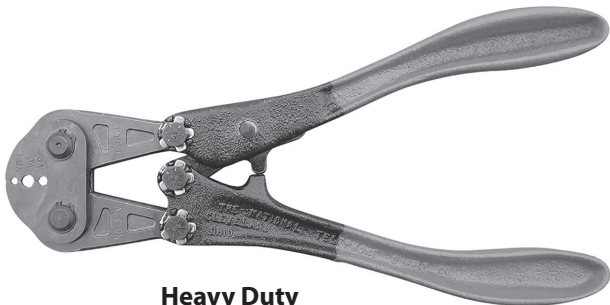

Heavy Duty

Heavy-Duty Crimping Tools are rugged hand tools engineered for the toughest field conditions. Manufactured from forged alloy steel with hardened working surfaces. These tools are designed to effectively crimp Duplex Ferrules by creating maximum holding around the wire, resulting in strong, reliable connections. Jaws have multiple marked pressing grooves to match the different ferrule sizes. CL-2-DF requires two crimps per ferrule, while CL-3-DF requires three crimps per ferrule.

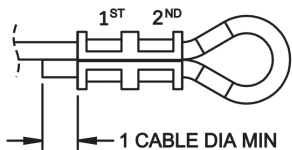

**Cable #2
Two Crimps**
(Sequence Option 1)

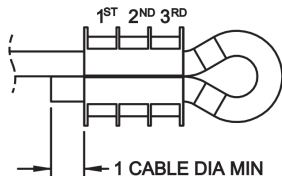

**Cable #3
Three Crimps**
(Sequence Option 1)

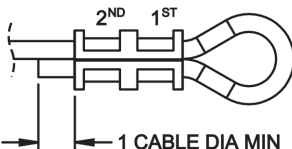

**Cable #2
Two Crimps**
(Sequence Option 2)

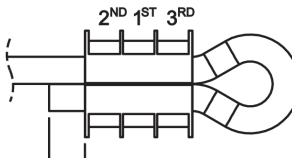

**Cable #3
Three Crimps**
(Sequence Option 2)



**Crimp Gauge
(Included with
Crimping Tool)**

HEAVY-DUTY CRIMPING TOOL

PART NO.	CRIMPING GROOVE IN JAWS
CL-2-CTDF	VB4 for Duplex Ferrule CL-2-DF VG for Duplex Ferrule CL-3-DF

NYLON LANYARDS

ZYTEL® HIGH-STRENGTH NYLON, BLACK

1



High-strength nylon lanyard with one eyelet end and one loop end. The eyelet end can be fastened with a screw. The loop end is supplied open – simply snap together to create a permanent assembly. Snap assembly allows on-site attachment without a crimping tool. These economical lanyards are ideal for applications where the attached item is occasionally removed, by cutting the lanyard, and replaced.

Available in one length (10" assembled). Eyelet accepts a #10 or M5 screw. A minimum pass-through diameter of 3/8" is required for attachment. Made in USA.

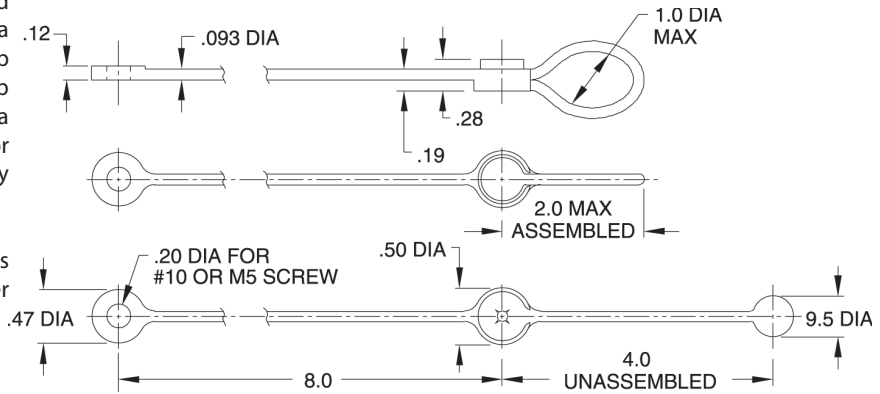

PART NO.	LANYARD DIA	LENGTH (ASSEMBLED)	EYELET	
			ID	FOR SCREW
CL-1-NL-10	.093	10	.20	#10 OR M5

BALL LOCK COUPLING RINGS

PIN AND RECEIVER: 303 STAINLESS STEEL
RINGS, SPRING, AND BALLS: STAINLESS STEEL



This tiny quick-release coupling assembly incorporates a rugged, high-quality Ball Lock Pin mechanism. Allows quick, reliable connection and disconnection of items attached to a cable assembly. Simply press the button to release. One half of the coupling ring is essentially a small Ball Lock Pin with a split ring through the push button; the other half is a mating receiver, also with a split ring through it. The coupling is positive locking until released by pushing the button, which moves the center spindle forward to allow the locking balls to retract. Made of 300-series stainless steel for excellent corrosion resistance. Note: photo at left is shown actual size.

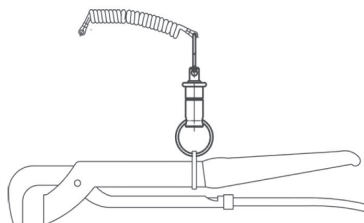
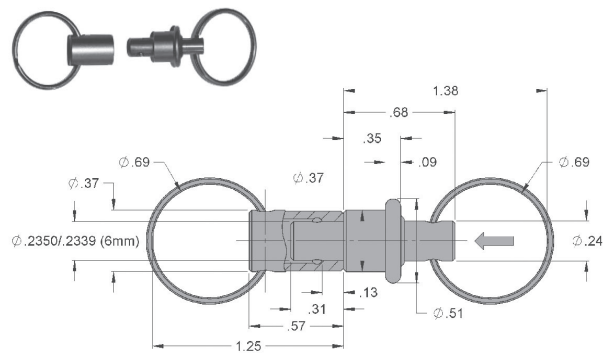

PART NO.	PIN DIA	RATED LOAD CAPACITY (LBS)	MAXIMUM OPERATING TEMPERATURE
CLM-6-BLCR-S	6MM	7	480°F

HOIST RINGS

2



Swivel Hoist Rings



Side-Pull Hoist Rings

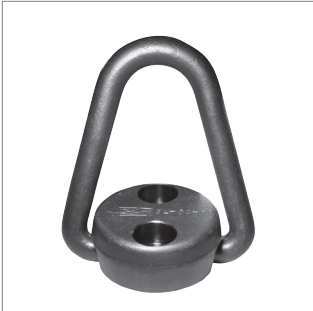

Pivoting Hoist Rings



Lifting Eyes



Hoist Eye 360°



Hoist Ring Accessories

Also see:



Lifting Pins
p. 58-59

HOIST RINGS

SELECTION CHART:

2

CAPACITY	SWIVEL			SIDE-PULL	PIVOTING	LIFTING EYES	HOIST EYE 360°
	STEEL	STAINLESS	NICKEL				
< 500 LBS	X	X				X	
500-999 LBS.	X		X	X		X	X
1,000-2,499 LBS.	X	X	X	X	X	X	X
2,500-4,999 LBS.	X	X	X	X	X	X	X
5,000-7,499 LBS.	X	X		X	X	X	X
7,500-9,999 LBS.	X	X		X	X	X	
10,000-24,999 LBS.	X	X		X	X	X	
>25,000 LBS.	X	X					

HOIST RING SAFETY PRECAUTIONS

INFO+: The following safety precautions apply to all lifting devices on pages 75, 76-90 and page 58. Also see these individual pages for additional precautions and installation guidelines.

1. **IMPORTANT!** The load on each hoist ring is not simply total weight divided by the number of hoist rings. The resultant force can be significantly greater at shallow lift angles and with unevenly distributed loads. See the example below:

F = Force on each hoist ring
 W = Total weight = 4000 lbs.
 N = Number of hoist rings = 4
 A = Lifting angle

$$F = \frac{W}{N \sin A}$$

If A = 70°, F = $\frac{4000}{4 \sin 70^\circ} = 1064$ lbs.

If A = 15°, F = $\frac{4000}{4 \sin 15^\circ} = 3864$ lbs.

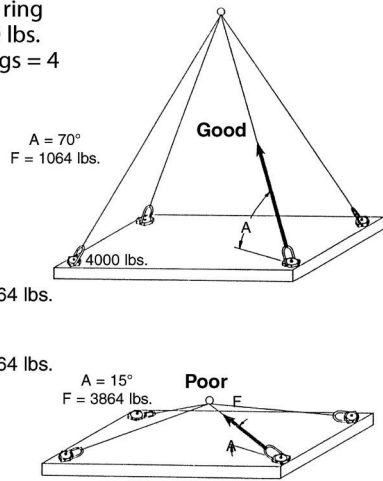

2. Despite the 5:1 safety factor on hoist rings, never exceed the rated load capacity. This safety margin is needed in case of misuse, which could drastically lower load capacity.

3. Tensile strength of parent material should be above 80,000 psi to achieve full load rating. For weaker material, consider through-hole mounting with a nut and washer on the other side.

4. Do not allow hoist rings to bind. Use a spreader bar, if necessary, to avoid binding.

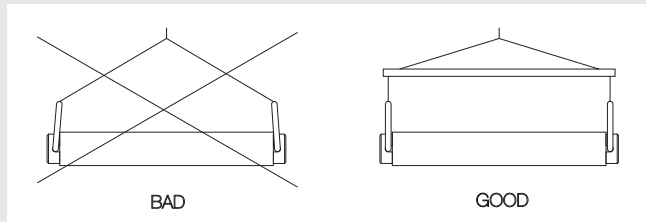

5. Do not use spacers between the hoist ring and the mounting surface.

6. Mounting surface must be flat and smooth for full contact under hoist ring. Tapped mounting holes must be perpendicular to the mounting surface.

7. Tighten mounting screws to the torque recommended. Periodically check torque because screws could loosen in extended service. For hoist rings not furnished with screws, mount using only high-quality socket-head cap screws.

8. Never lift with a hook or other device that could deform the lifting ring.

9. Do not apply shock loads. Always lift gradually. Repeat magnaflux testing if shock loading ever occurs.

10. After installation, check that ring rotates and pivots freely in all directions.

HOIST RINGS

2

TYPES



SWIVEL HOIST RINGS

The original, patented safety-engineered Hoist Ring, and the only one that has a production sample destructively pull tested to guarantee each production run meets or exceeds the 5:1 safety factor. Pivots 180 degrees and swivels 360 degrees simultaneously to allow lifting from any direction. Black oxide finish is standard, with cadmium plating available as a special. Also available in 300-series stainless steel, with a load rating equal to 50% of the steel version. Heavy duty versions are available in capacities up to 250,000 lbs. Some varieties available electroless nickel plated, for a less-hazardous corrosion-resistant finish. Made in USA. **INFO+:** Pages 76-83.



SIDE-PULL HOIST RINGS

Required for side mounting. Flip and turn loads without unhooking (use with a spreader bar). Forged alloy-steel ring pivots 180 degrees and swivels 360 degrees simultaneously to allow lifting from any direction. Large, weldless forged ring can accommodate larger lifting hooks. Meets OSHA standards and military specifications MIL-STD-209J and MIL-STD-1365(11). Safety factor = 5:1. Made in USA. **INFO+:** Pages 86-87.



PIVOTING HOIST RINGS

An economical lifting device ideal for permanent installation. Also has a low profile and high load capacity. Forged base and solid-loop forged ring. Pivots a full 180 degrees, but does not rotate. Safety factor = 5:1. Made in USA. **INFO+:** Page 88.



LIFTING EYES

Forged steel eyebolts with an integral shoulder for greater strength. These simple, economical products are suitable for vertical lifting in-line with the threaded bolt, such as when lifting from a single point or from two points with a spreader bar. For lifting at an angle, Swivel Hoist Rings should be used instead. Manufactured and tested according to ASTM A489 and ANSI B18.15 specifications. Safety factor = 5:1. Made in USA. **INFO+:** Page 89.



HOIST EYE 360®

Hoist Eye 360® is a forged lifting eye that can be rotated 360° after installation, to align with the pulling direction. This compact assembly features a specially designed shoulder bolt, which rotates freely in the precisely machined lifting-eye body and is held captive by a retaining ring. Unlike conventional lifting eyes, Hoist Eye 360® can be used at full rated load capacity when pulling at any angle 0 to 90° from the bolt axis. Safety factor = 5:1. Made in USA. **INFO+:** Page 90.

MATERIALS

STEEL

Alloy steel, heat treated, black oxide finish (cadmium plating available as a special). Every production lot of swivel Hoist Rings is subjected to testing, including the industry's most rigorous pull testing. We destructively pull test every production lot to ensure that they meet or exceed our 5:1 safety factor.

STAINLESS STEEL

The stainless steel version of our original, patented safety-engineered hoist ring comes with a load rating equal to 50% of the steel version. Useful for corrosive, cryogenic, or elevated-temperature environments.

NICKEL-PLATED STEEL

Alloy-steel Swivel Hoist Rings are available with electroless nickel plating. This optional finish offers excellent corrosion and wear resistance while still providing the full load capacity of our heat-treated alloy-steel hoist rings.

All hoist rings are made in the USA, and available DFARS and RoHS compliant.

SWIVEL HOIST RINGS

ALLOY STEEL, HEAT TREATED, BLACK OXIDE FINISH, 100% MAGNAFLUX INSPECTED

2



The original safety-engineered hoist ring. Pivots 180 degrees and swivels 360 degrees simultaneously to allow lifting from any direction. Safety factor = 5:1. Black oxide finish is standard, with cadmium plating available as a special (add -C to part number). Swivel Hoist Rings are also available in 300-series stainless steel, with a load rating equal to 50% of the steel version. **Patent no. 3,297,293 and 4,705,422.**

Fasten hoist rings using the installation torque specified in the dimension table. Always install so that the hoist ring can pivot and swivel freely. Some hoist rings are available with a choice of bolt lengths. Use the shortest bolt length only for steel plates, the other lengths for weaker materials and for through-hole mounting with a washer and nut. **INFO+:** See general Hoist Ring Safety Precautions on page 74.

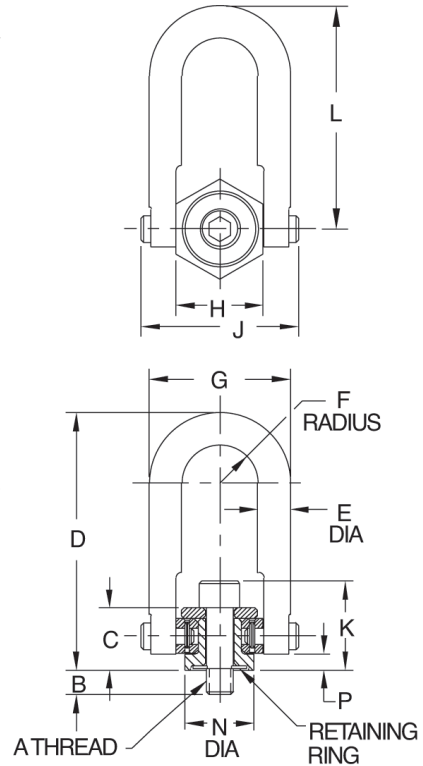
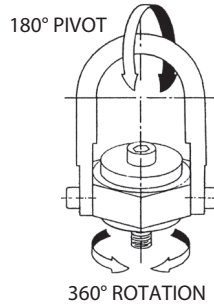

STANDARD RING (INCH)

PART NO.	LOAD RATING (LBS)	A	B	C	D	E DIA	F	G	H	J	K	L	N DIA	P	INSTALLATION TORQUE (FT-LBS)	REPLACEMENT BOLT (WITH RETAINING RING)
CL-550-SHR-2	550	1/4-20	.54	.71	2.67	3/8	.43	1.61	1.00	1.84	.96	2.31	.75	.17	5	—
CL-800-SHR-1	800	5/16-18	.29	.72	2.63	3/8	.44	1.62	1.00	1.82	1.03	2.35	.75	.17	7	CL-800-SHRB-1
CL-800-SHR-2			.54													CL-800-SHRB-2
CL-1000-SHR-1	1000	3/8-16	.54	.72	2.63	3/8	.44	1.62	1.00	1.82	1.09	2.35	.75	.17	12	CL-1000-SHRB-1
CL-23301-SHR	2500	1/2-13	1.07	.93	3.77	1/2	.70	2.40	1.49	2.58	1.43	3.31	1.25	.20	28	CL-23318-SHRB-1
CL-2500-SHR-1			.77													CL-2500-SHRB-1
CL-2500-SHR-2	2500	1/2-13	1.02	1.23	4.77	3/4	.88	3.25	2.00	3.52	1.73	4.24	1.50	.16	28	CL-2500-SHRB-2
CL-2500-SHR-3			1.27													CL-2500-SHRB-3
CL-4000-SHR-1			.77													CL-4000-SHRB-1
CL-4000-SHR-2	4000	5/8-11	1.02	1.23	4.77	3/4	.88	3.25	2.00	3.52	1.86	4.24	1.50	.16	60	CL-4000-SHRB-2
CL-4000-SHR-3			1.27													CL-4000-SHRB-3
CL-5000-SHR-1	5000	3/4-10	1.02	1.23	4.77	3/4	.88	3.25	2.00	3.52	1.98	4.24	1.50	.16	100	CL-5000-SHRB-1
CL-5000-SHR-2			1.52													CL-5000-SHRB-2
CL-7000-SHR-1	7000	3/4-10	1.03	1.72	6.55	1-1/16	1.40	4.94	3.00	5.06	2.47	5.80	2.37	.24	100	CL-7000-SHRB-1
CL-7000-SHR-2			1.53													CL-7000-SHRB-2
CL-8000-SHR-1	8000	7/8-9	1.03	1.72	6.55	1-1/16	1.40	4.94	3.00	5.06	2.60	5.80	2.37	.24	160	CL-8000-SHRB-1
CL-8000-SHR-2			1.53													CL-8000-SHRB-2
CL-10000-SHR-1	10000	1"-8	1.28	1.72	6.55	1-1/16	1.40	4.94	3.00	5.06	2.72	5.80	2.37	.24	230	CL-10000-SHRB-1
CL-10000-SHR-2			1.53													CL-10000-SHRB-2
CL-10000-SHR-3			2.28													CL-10000-SHRB-3
CL-15000-SHR-1	15000	1-1/4"-7	1.89	2.11	8.73	1-1/4	1.75	6.00	3.76	6.50	3.36	7.75	3.20	.35	470	CL-15000-SHRB-1
CL-24000-SHR-1	24000	1-1/2"-6	2.70	2.81	12.47	1-3/4	2.25	8.00	4.87	8.55	4.36	11.12	4.20	.47	800	CL-24000-SHRB-1
CL-23200-SHR	30000	2"-4-1/2	2.96	2.81	12.47	1-3/4	2.25	8.00	4.87	8.55	5.36	11.12	4.20	.47	1100	—
CL-23503-SHR	50000	2-1/2"-4	4.00	4.09	16.87	2-1/4	3.00	10.50	6.52	11.67	6.59	14.50	5.75	1.12	2100	—
CL-23501-SHR		2-1/2"-8														—
CL-23600-SHR	75000	3"-4	5.20	5.20	19.50	2-3/4	3.75	13.00	8.10	14.15	8.27	17.00	7.25	1.00	4300	—
CL-23701-SHR	100000	3-1/2"-4	7.00	7.00	22.09	3-1/4	4.00	14.50	8.60	15.90	9.56	19.25	7.75	1.09	6600	—

CONTINUED ON NEXT PAGE

SWIVEL HOIST RINGS

STANDARD RING (METRIC)

PART NO.	LOAD RATING (kg)	A THREAD	B (mm)	C (mm)	D (mm)	E DIA (mm)	F (mm)	G (mm)	H (mm)	J (mm)	K (mm)	L (mm)	N DIA (mm)	P (mm)	INSTALLATION TORQUE (Nm)
CLM-800-SHR-2	400	M8	17	18	67	9.5	11	41	25.5	46	26	60	19	4.5	9
CLM-1000-SHR-1	450	M10	17	18	67	9.5	11	41	25.5	46	28	60	19	4.5	16
CLM-2500-SHR-1	1050	M12	19	31	121	19	22	83	51	89	43	108	38	4	37
CLM-4000-SHR-2	1900	M16	29	31	121	19	22	83	51	89	47	108	38	4	80
CLM-24020-SHR	2200	M20	30	31	121	19	22	83	51	89	51	108	38	4	136
CLM-7000-SHR-2	3000	M20	32	44	166	27	36	125	76	129	64	147	59	6	136
CLM-9000-SHR-2	4200	M24	37	44	166	27	36	125	76	129	68	147	59	6	216
CLM-10000-SHR-1	4500	M30	54	43	166	25.5	36	122	76	131	69	147	59	6	310
CLM-15000-SHR-1	7000	M30	46	54	222	32	44	152	96	165	85	197	81	9	640
CLM-24042-SHR	7000	M30	66	54	222	32	44	152	96	165	85	197	81	9	640
CLM-24000-SHR-1	11000	M36	69	71	317	44	57	203	124	217	111	282	107	12	1100
CLM-27000-SHR-1	12500	M42	79	71	317	44	57	203	124	217	123	282	107	12	1100
CLM-30000-SHR-1	13500	M48	79	71	317	44	57	203	124	217	136	282	107	12	1100
CLM-24060-SHR	22000	M64	102	104	428	57	76	267	166	296	168	368	146	28	2800
CLM-24062-SHR	31500	M72	132	134	495	70	95	330	206	368	210	432	184	25	5700
CLM-24064-SHR	51000	M90	178	154	561	83	102	368	218	404	243	489	197	28	9600

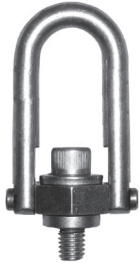

Optional Long-Ring Version

Long-ring version provides extra reach and allows using larger lifting hooks.

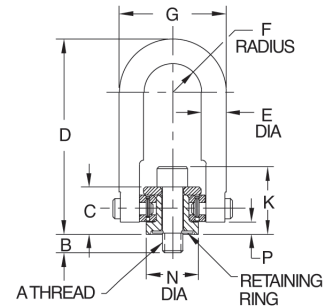
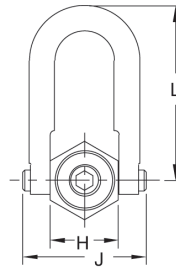

LONG RING (INCH)

PART NO.	LOAD RATING (LBS)	A	B	C	D	E DIA	F	G	H	J	K	L	N DIA	P	INSTALLATION TORQUE (FT-LBS)	REPLACEMENT BOLT WITH (RETAINING RING)
CL-23322-SHR	2500	1/2-13	.78	1.22	6.72	3/4	.88	3.25	1.99	3.52	1.72	6.19	1.50	.16	28	CL-23024-SHRB
CL-23323-SHR			1.03													CL-23025-SHRB
CL-23324-SHR			1.28													CL-23026-SHRB
CL-23320-SHR	4000	5/8-11	1.03	1.22	6.72	3/4	.88	3.25	1.99	3.52	1.85	6.19	1.50	.16	60	CL-23022-SHRB
CL-23321-SHR			1.28													CL-23023-SHRB
CL-23325-SHR	5000	3/4-10	1.03	1.22	6.72	3/4	.88	3.25	1.99	3.52	1.97	6.19	1.50	.16	100	CL-23027-SHRB
CL-23327-SHR			1.53													CL-23029-SHRB
CL-23329-SHR	7000	3/4-10	1.04	1.71	8.11	1	1.40	4.80	3.00	5.14	2.46	7.38	2.37	.24	100	CL-23122-SHRB
CL-23330-SHR			1.54													CL-23123-SHRB
CL-23328-SHR			8000													7/8-9
CL-23331-SHR	10000	1"-8	1.29	1.71	8.11	1	1.40	4.80	3.00	5.14	2.71	7.38	2.37	.24	230	CL-23125-SHRB
CL-23332-SHR			1.54													CL-23126-SHRB
CL-23333-SHR			2.29													CL-23127-SHRB

LONG RING (METRIC)

PART NO.	LOAD RATING (kg)	A THREAD	THREAD PITCH (mm)	B (mm)	C (mm)	D (mm)	E DIA (mm)	F (mm)	G (mm)	H (mm)	J (mm)	K (mm)	L (mm)	N DIA (mm)	P (mm)	INSTALLATION TORQUE (Nm)
CLM-24014-SHR	1050	M12	1.75	19	31	171	19	22	83	51	89	43	157	38	4	37
CLM-24018-SHR	1900	M16	2	24	31	171	19	22	83	51	89	47	157	38	4	80
CLM-24021-SHR	2200	M20	2.5	30	31	171	19	22	83	51	89	51	157	38	4	136
CLM-24023-SHR	3000	M20	2.5	29	43	206	25.5	36	121	76	131	64	187	60	6	136
CLM-24026-SHR	4200	M24	3	34	43	206	25.5	36	121	76	131	67	187	60	6	310
CLM-24032-SHR	4500	M30	3.5	54	43	206	25.5	36	121	76	131	73	187	60	6	310

NICKEL-PLATED SWIVEL HOIST RINGS

ALLOY STEEL, HEAT TREATED, ELECTROLESS NICKEL PLATED, 100% MAGNAFLUX INSPECTED

2



Nickel Plated

Our original alloy-steel Swivel Hoist Rings are now available with electroless nickel plating. These hoist rings offer excellent corrosion and wear resistance while still providing the full load capacity of our heat-treated alloy-steel hoist rings. Electroless nickel is a hard, uniform coating that is very resistant to a wide range of chemicals, which makes these hoist rings suitable for many corrosive and marine environments. Swivel Hoist Rings pivot 180 degrees and swivel 360 degrees simultaneously to allow lifting from any direction. Safety factor = 5:1. **Patent no. 3,297,293 and 4,705,422.**

Fasten hoist rings using the installation torque specified in the dimension table. Always install so that the hoist ring can pivot and swivel freely. Some hoist rings are available with a choice of bolt lengths. Use the shortest bolt length only for steel plates, the other lengths for weaker materials and for through-hole mounting with a washer and nut. **INFO+:** See general Hoist Ring Safety Precautions on page 74.

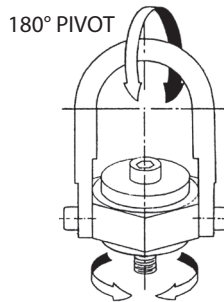
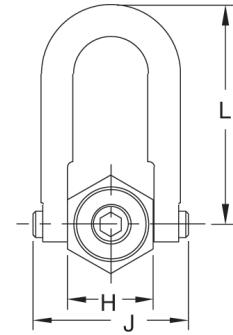

360° ROTATION

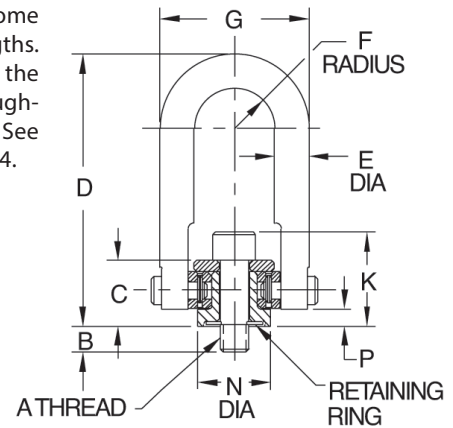

STANDARD RING, ELECTROLESS NICKEL PLATED (INCH)

PART NO.	LOAD RATING (LBS)	A	B	C	D	E DIA	F	G	H	J	K	L	N DIA	P	INSTALLATION TORQUE (FT-LBS)	REPLACEMENT BOLT (WITH RETAINING RING)
CL-800-SHR-2-N	800	5/16-18	.54	.72	2.63	3/8	.44	1.62	1.00	1.82	1.03	2.35	.75	.17	7	CL-800-SHRB-2-N
CL-1000-SHR-1-N	1000	3/8-16	.54	.72	2.63	3/8	.44	1.62	1.00	1.82	1.09	2.35	.75	.17	12	CL-1000-SHRB-1-N
CL-2500-SHR-1-N	2500	1/2-13	.77	1.23	4.77	3/4	.88	3.25	2.00	3.52	1.73	4.24	1.50	.16	28	CL-2500-SHRB-1-N
CL-2500-SHR-2-N			1.02													CL-2500-SHRB-2-N
CL-2500-SHR-3-N			1.27													CL-2500-SHRB-3-N
CL-4000-SHR-1-N	4000	5/8-11	.77	1.23	4.77	3/4	.88	3.25	2.00	3.52	1.86	4.24	1.50	.16	60	CL-4000-SHRB-1-N
CL-4000-SHR-2-N			1.02													CL-4000-SHRB-2-N
CL-4000-SHR-3-N			1.27													CL-4000-SHRB-3-N
CL-5000-SHR-1-N	5000	3/4-10	1.02	1.23	4.77	3/4	.88	3.25	2.00	3.52	1.98	4.24	1.50	.16	100	CL-5000-SHRB-1-N
CL-5000-SHR-2-N			1.52													CL-5000-SHRB-2-N

STANDARD RING, ELECTROLESS NICKEL PLATED (METRIC)

PART NO.	LOAD RATING (kg)	A THREAD	THREAD PITCH (mm)	B (mm)	C (mm)	D (mm)	E DIA (mm)	F (mm)	G (mm)	H (mm)	J (mm)	K (mm)	L (mm)	N DIA (mm)	P (mm)	INSTALLATION TORQUE (Nm)
CLM-800-SHR-2-N	400	M8	1.25	17	18	67	9.5	11	41	25.5	46	26	60	19	4.5	9
CLM-1000-SHR-1-N	450	M10	1.5	17	18	67	9.5	11	41	25.5	46	28	60	19	4.5	16
CLM-2500-SHR-1-N	1050	M12	1.75	19	31	121	19	22	83	51	89	43	108	38	4	37
CLM-4000-SHR-2-N	1900	M16	2	29	31	121	19	22	83	51	89	47	108	38	4	80

STAINLESS SWIVEL HOIST RINGS

300-SERIES STAINLESS STEEL, PASSIVATED, 100% LIQUID-PENETRANT INSPECTED



Stainless Steel

Stainless steel version of our original safety-engineered hoist ring, with a load rating equal to 50% of the alloy steel version. Useful for corrosive, cryogenic, or elevated-temperature environments. Pivots 180 degrees and swivels 360 degrees simultaneously to allow lifting from any direction. Safety factor = 5:1. **Patent no. 3,297,293 and 4,705,422.**

Fasten hoist rings using the installation torque specified in the dimension table. Always install so that the hoist ring can pivot and swivel freely. Some hoist rings are available with a choice of bolt lengths. Use the shortest bolt length only for steel plates, the other lengths for weaker materials and for through-hole mounting with a washer and nut. **INFO+:** See general Hoist Ring Safety Precautions on page 74.

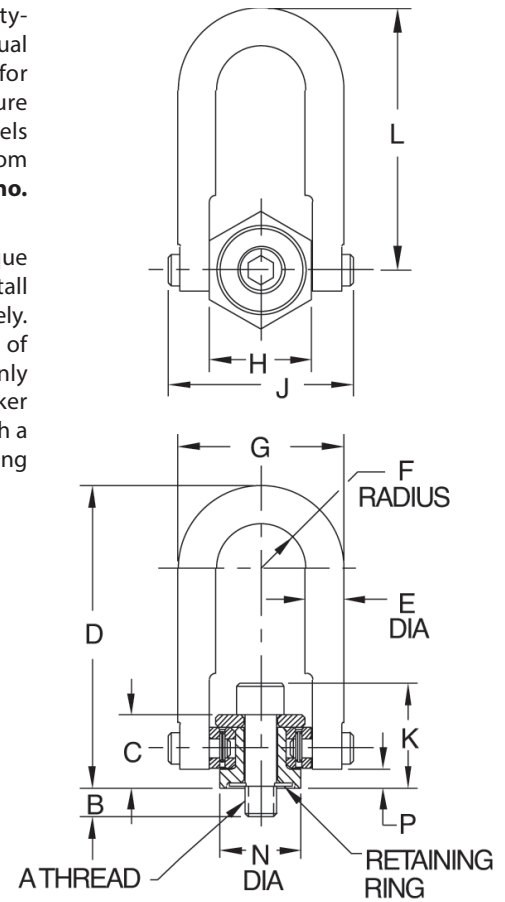
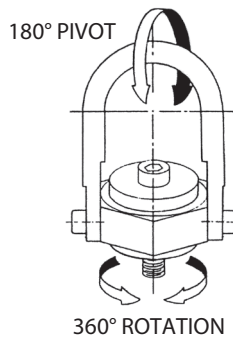

STANDARD RING — STAINLESS STEEL (INCH)

PART NO.	LOAD RATING (LBS)	A	B	C	D	E DIA	F	G	H	J	K	L	N DIA	P	INSTALLTION TORQUE (FT-LBS)
CL-275-SHR-1-S	275	1/4-20	.54	.71	2.67	3/8	.43	1.61	1.00	1.84	.96	2.31	.75	.17	2.5
CL-400-SHR-2-S	400	5/16-18	.54	.71	2.67	3/8	.43	1.61	1.00	1.84	.96	2.31	.75	.17	3.5
CL-500-SHR-1-S	500	3/8-16	.54	.71	2.67	3/8	.43	1.61	1.00	1.84	1.09	2.31	.75	.17	6
CL-29301-SHR-S	1250	1/2-13	1.07	.93	3.77	1/2	.70	2.40	1.49	2.58	1.43	3.31	1.25	.20	4
CL-1250-SHR-1-S	1250	1/2-13	.78	1.22	4.78	3/4	.88	3.25	1.99	3.52	1.72	4.25	1.50	.16	14
CL-1250-SHR-2-S			1.03												
CL-1250-SHR-3-S			1.28												
CL-2000-SHR-1-S	2000	5/8-11	.78	1.22	4.78	3/4	.88	3.25	1.99	3.52	1.85	4.25	1.50	.16	30
CL-2500-SHR-1-S	2500	3/4-10	1.03	1.22	4.78	3/4	.88	3.25	1.99	3.52	1.97	4.25	1.50	.16	50
CL-29102-SHR-S	3500	3/4-10	1.04	1.71	6.52	1	1.40	4.80	3.00	5.14	2.46	5.78	2.37	.24	50
CL-29103-SHR-S			1.54												
CL-29101-SHR-S			1.04												
CL-29105-SHR-S	5000	1"-8	1.29	1.71	6.52	1	1.40	4.80	3.00	5.14	2.71	5.78	2.37	.24	115
CL-29106-SHR-S			1.54												
CL-29107-SHR-S			2.29												
CL-29401-SHR-S	7500	1-1/4"-7	1.89	2.11	8.73	1-1/4	1.75	6.00	3.76	6.50	3.36	7.75	3.20	.35	235
CL-29202-SHR-S	12000	1-1/2"-6	2.70	2.81	12.47	1-3/4	2.25	8.00	4.87	8.55	4.31	11.12	4.20	.47	400
CL-29200-SHR-S	15000	2"-4-1/2	2.96	2.81	12.47	1-3/4	2.25	8.00	4.87	8.55	5.31	11.12	4.20	.47	550
CL-29503-SHR-S	25000	2-1/2"-4	4.00	4.09	16.87	2-1/4	3.00	10.50	6.52	11.67	6.59	14.50	5.75	1.12	1050
CL-29501-SHR-S		2-1/2"-8													
CL-29600-SHR-S	37500	3"-4	5.20	5.27	19.50	2-3/4	3.75	13.00	8.10	14.15	8.27	17.00	7.25	1.00	2150
CL-29701-SHR-S	50000	3-1/2"-4	7.00	6.06	22.09	3-1/4	4.00	14.50	8.60	15.90	9.56	19.25	7.75	1.09	3300

CONTINUED ON NEXT PAGE

STAINLESS SWIVEL HOIST RINGS

STANDARD RING — STAINLESS STEEL (METRIC)

PART NO.	LOAD RATING (kg)	A THREAD	THREAD PITCH (mm)	B (mm)	C (mm)	D (mm)	E DIA (mm)	F (mm)	G (mm)	H (mm)	J (mm)	K (mm)	L (mm)	N DIA (mm)	P (mm)	INSTALLATION TORQUE (Nm)
CLM-440-SHR-2-S	200	M8	1.25	17	18	68	9.5	11	41	25.5	47	26	59	19	4.5	5
CLM-500-SHR-1-S	225	M10	1.5	17	18	68	9.5	11	41	25.5	47	28	59	19	4.5	8
CLM-1150-SHR-1-S	525	M12	1.75	19	31	121	19	22	83	51	89	43	108	38	4	19
CLM-2000-SHR-2-S	950	M16	2	24	31	121	19	22	83	51	89	47	108	38	4	41
CLM-2400-SHR-2-S	1100	M20	2.5	30	31	121	19	22	83	51	89	51	108	38	4	68
CLM-29822-SHR-S	1500	M20	2.5	29	43	166	25.5	36	121	76	131	64	147	59	6	68
CLM-29824-SHR-S	2100	M24	3	34	43	166	25.5	36	121	76	131	67	147	59	6	156
CLM-29830-SHR-S	2250	M30	3.5	54	43	166	25.5	36	121	76	131	73	147	59	6	156
CLM-29840-SHR-S	3500	M30	3.5	46	54	222	32	44	152	96	165	84	197	81	9	320
CLM-29842-SHR-S	3500	M30	3.5	66	54	222	32	44	152	96	165	84	197	81	9	320
CLM-29850-SHR-S	5500	M36	4	69	71	317	44	57	203	124	217	107	282	107	12	540
CLM-29852-SHR-S	6250	M42	4.5	79	71	317	44	57	203	124	217	113	282	107	12	540
CLM-29854-SHR-S	7250	M48	5	79	71	317	44	57	203	124	217	119	282	107	12	540
CLM-29860-SHR-S	11000	M64	6	102	104	428	57	76	267	166	296	168	368	146	28	1400

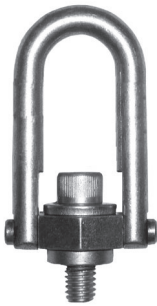

Optional Long-Ring Version

Long-ring version provides extra reach and allows using larger lifting hooks.

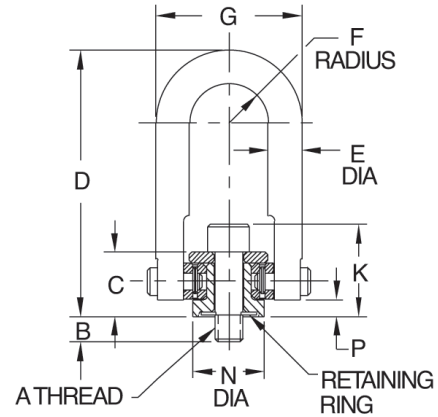
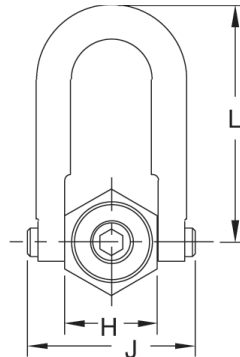

LONG RING — STAINLESS STEEL (INCH)

PART NO.	LOAD RATING (LBS)	A	B	C	D	E DIA	F	G	H	J	K	L	N DIA	P	INSTALLATION TORQUE (FT-LBS)
CL-29322-SHR-S	1250	1/2-13	.78	1.22	6.72	3/4	.88	3.25	1.99	3.52	1.72	6.19	1.50	.16	14
CL-29323-SHR-S			1.03												
CL-29324-SHR-S			1.28												
CL-29320-SHR-S	2000	5/8-11	1.03	1.22	6.72	3/4	.88	3.25	1.99	3.52	1.85	6.19	1.50	.16	30
CL-29321-SHR-S			1.28												
CL-29325-SHR-S	2500	3/4-10	1.03	1.22	6.72	3/4	.88	3.25	1.99	3.52	1.97	6.19	1.50	.16	50
CL-29327-SHR-S			1.53												
CL-29329-SHR-S	3500	3/4-10	1.04	1.71	8.11	1	1.40	4.80	3.00	5.14	2.46	7.38	2.37	.24	50
CL-29330-SHR-S			1.54												
CL-29328-SHR-S	4000	7/8-9	1.04	1.71	8.11	1	1.40	4.80	3.00	5.14	2.59	7.38	2.37	.24	80
CL-29331-SHR-S	5000	1"-8	1.29	1.71	8.11	1	1.40	4.80	3.00	5.14	2.71	7.38	2.37	.24	115
CL-29332-SHR-S			1.54												
CL-29333-SHR-S			2.29												

LONG RING — STAINLESS STEEL (METRIC)

PART NO.	LOAD RATING (kg)	A THREAD	THREAD PITCH (mm)	B (mm)	C (mm)	D (mm)	E DIA (mm)	F (mm)	G (mm)	H (mm)	J (mm)	K (mm)	L (mm)	N DIA (mm)	P (mm)	INSTALLATION TORQUE (Nm)
CLM-29814-SHR-S	525	M12	1.75	19	31	171	19	22	83	51	89	43	157	38	4	19
CLM-29818-SHR-S	950	M16	2	24	31	171	19	22	83	51	89	47	157	38	4	41
CLM-29821-SHR-S	1100	M20	2.5	30	31	171	19	22	83	51	89	51	157	38	4	68
CLM-29823-SHR-S	1500	M20	2.5	29	43	206	25.5	36	121	76	131	64	187	60	6	68
CLM-29826-SHR-S	2100	M24	3	34	43	206	25.5	36	121	76	131	67	187	60	6	156
Please contact factory	2250	M30	3.5	54	43	206	25.5	36	121	76	131	73	187	60	6	320

EZ-TORQUE® SWIVEL HOIST RINGS

ALLOY STEEL, HEAT TREATED, BLACK OXIDE FINISH, 100% MAGNAFLUX INSPECTED



**E-Z Torque®
Swivel Hoist Rings**

Extra-large Swivel Hoist Rings with our patented system that allows tightening several smaller bolt heads with a standard torque wrench instead of tightening one large bolt with a special tool. Swivel Hoist Rings pivot 180 degrees and swivel 360 degrees simultaneously to allow lifting from any direction. Safety factor = 5:1. Black oxide finish is standard, with cadmium plating available as a special. Available in load capacities up to 250000 lbs. **Patent no. 3,297,293, 4,705,422, and 6,199,925.** Fasten hoist rings using the installation torque specified in the dimension table. Always install so that the hoist ring can pivot and swivel freely. **INFO+:** See general Hoist Ring Safety Precautions on page 74.

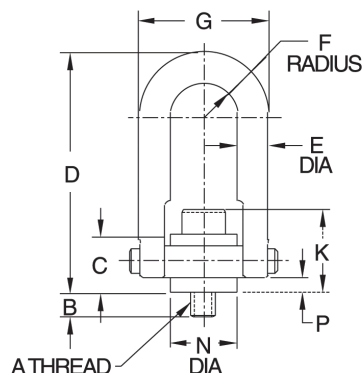
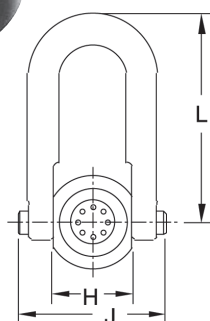
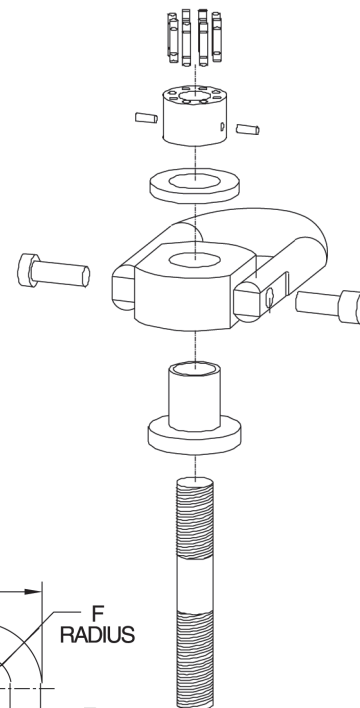

INCH

PART NO.	LOAD RATING (LBS)	A	B	C	D	E DIA	F	G	H	J	K	L	N DIA	P	INSTALLATION TORQUE (FT-LBS)
CL-23490-SHR	15000	1-1/4"-7	1.89	2.11	8.73	1-1/4	1.75	6.0	3.76	6.50	3.60	7.75	3.20	.35	10
CL-23494-SHR	24000	1-1/2"-6	2.70	2.81	12.47	1-3/4	2.25	8.0	4.87	8.55	4.60	11.12	4.20	.47	18
CL-23290-SHR	30000	2"-4-1/2	2.96	2.81	12.47	1-3/4	2.25	8.0	4.87	8.55	4.60	11.12	4.20	.47	26
CL-23592-SHR	50000	2-1/2"-4	4.00	4.09	16.87	2-1/4	3.00	10.5	6.52	11.67	6.89	14.50	5.75	1.12	49
CL-23590-SHR		2-1/2"-8													
CL-23690-SHR	75000	3"-4	5.20	5.27	19.50	2-3/4	3.75	13.0	8.10	14.15	8.72	17.00	7.25	1.00	92
CL-23790-SHR	100000	3-1/2"-4	7.00	6.06	22.09	3-1/4	4.00	14.5	8.60	15.90	9.56	19.25	7.75	1.09	98
CL-23792-SHR	150000	4-1/4"-4	8.50	7.50	27.38	4	5.00	18.0	10.75	19.69	10.45	23.81	9.87	1.33	123
CL-23794-SHR	200000	5"-4	9.00	9.00	33.00	5	6.00	22.0	13.00	24.00	13.00	28.50	12.38	1.88	193
CL-23798-SHR	250000	6"-4	9.00	9.00	33.00	5	6.00	22.0	13.00	24.00	13.00	28.50	12.38	1.88	207

METRIC

PART NO.	LOAD RATING (kg)	A THREAD	THREAD PITCH (mm)	B (mm)	C (mm)	D (mm)	E DIA (mm)	F (mm)	G (mm)	H (mm)	J (mm)	K (mm)	L (mm)	N DIA (mm)	P (mm)	INSTALLATION TORQUE (N-m)
CLM-24490-SHR	7000	M30	3.5	66	53.5	222	32	44.5	152.5	95.5	165	83.5	197	81.5	8.9	13.5
CLM-24494-SHR	11000	M36	4	69	71.5	317	44.5	57	203	123.5	217	107.5	282	106.5	11.9	20.8
CLM-24498-SHR	12500	M42	4.5	79	71.5	317	44.5	57	203	123.5	217	113.5	282	106.5	11.9	21.6
CLM-24290-SHR	13500	M48	5	79	71.5	317	44.5	57	203	123.5	217	119.5	282	106.5	11.9	21.3
CLM-24592-SHR	22000	M64	6	102	104	428	57	76	267	165.5	296	168	368	146	28.4	54
CLM-24690-SHR	31500	M72	6	132	134	495	70	95	330	206	368	210	432	184	25.4	125
CLM-24790-SHR	51000	M90	6	178	154	561	82.5	101.5	368	218	404	243	489	197	27.7	133

HEAVY-DUTY® SWIVEL HOIST RINGS

ALLOY STEEL, HEAT TREATED, BLACK OXIDE FINISH, 100% MAGNAFLUX INSPECTED

2



The next generation of Swivel Hoist Rings, with a heavy-duty forged steel ring. Pivots 180 degrees and swivels 360 degrees simultaneously to allow lifting from any direction. Safety factor = 5:1. Meets OSHA standards and Military Specification MIL-STD-1365(11) or MIL-STD-209C. **Patent no. 4,570,987 and 4,641,986, and other patents pending.**

Fasten hoist rings using the installation torque specified in the dimension table. Always install so that the hoist ring can pivot and swivel freely. Some hoist rings are available with a choice of bolt lengths. Use the shortest bolt length only for steel plates, the other lengths for weaker materials and for through-hole mounting with a washer and nut. **INFO+:** See general Hoist Ring Safety Precautions on page 74.

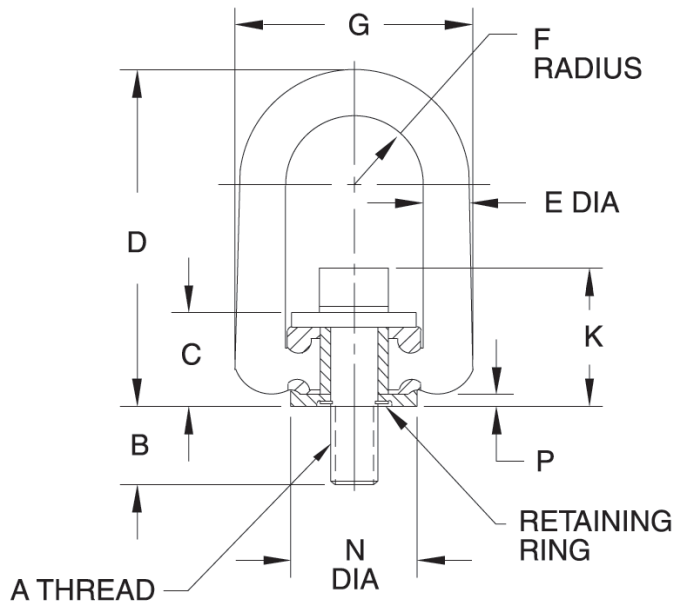
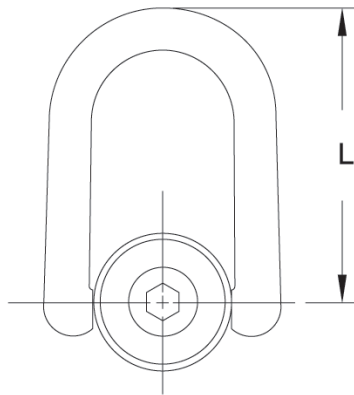

STANDARD RING (INCH)

PART NO.	LOAD RATING (LBS)	A	B	C	D	E DIA	F	G	K	L	N DIA	P	INSTALLATION TORQUE (FT-LBS)	REPLACEMENT BOLT (WITH RETAINING RING)
CL-33106-SHR	10000	1"-8	1.20	2.05	7.37	1.00	1.40	5.10	3.05	6.62	2.81	.18	230	CL-33126-SHRB
CL-33105-SHR			1.45											CL-33125-SHRB
CL-33107-SHR			2.20											CL-33127-SHRB
CL-33402-SHR	15000	1-1/4"-7	1.88	2.87	9.22	1.25	2.00	6.75	4.23	8.12	3.88	.32	470	CL-33419-SHRB
CL-33401-SHR			2.63											CL-33421-SHRB
CL-33420-SHR	20000	1-3/8"-6	2.63	2.87	9.22	1.25	2.00	6.75	4.35	8.12	3.88	.32	670	CL-33429-SHRB
CL-33424-SHR	24000	1-1/2"-6	2.63	2.87	9.22	1.25	2.00	6.75	4.48	8.12	3.88	.32	800	CL-33422-SHRB
CL-33427-SHR	30000	2"-4-1/2	2.96	2.87	9.22	1.25	2.00	6.75	4.48	8.12	3.88	.32	1100	—
CL-33432-SHR		2"-8												—

HEAVY-DUTY® SWIVEL HOIST RINGS

STANDARD RING (METRIC)

PART NO.	LOAD RATING (kg)	A THREAD	THREAD PITCH (mm)	B (mm)	C (mm)	D (mm)	E DIA (mm)	F (mm)	G (mm)	K (mm)	L (mm)	N DIA (mm)	P (mm)	INSTALLATION TORQUE (Nm)	REPLACEMENT BOLT (WITH RETAINING RING)
CLM-34212-SHR	400	M8	1.25	16	24.5	82	11	16.5	58	32.5	76	32	4	9.5	CLM-34252-SHRB
CLM-34214-SHR	400	M8	1.25	21	24.5	82	11	16.5	58	32.5	76	32	4	9.5	CLM-34254-SHRB
CLM-34312-SHR	450	M10	1.5	16	24.5	82	11	16.5	58	34.5	76	32	4	16	CLM-34352-SHRB
CLM-34314-SHR	450	M10	1.5	26	24.5	82	11	16.5	58	34.5	76	32	4	16	CLM-34354-SHRB
CLM-34515-SHR	1050	M12	1.75	25	38	135	19	25.5	89	51	121	48	4.4	37	CLM-34555-SHRB
CLM-34516-SHR	1050	M12	1.75	32	38	135	19	25.5	89	51	121	48	4.4	37	CLM-34556-SHRB
CLM-34614-SHR	1900	M16	2	25	38	135	19	25.5	89	54	121	48	4.4	80	CLM-34654-SHRB
CLM-34615-SHR	1900	M16	2	32	38	135	19	25.5	89	54	121	48	4.4	80	CLM-34655-SHRB
CLM-34714-SHR	2200	M20	2.5	25	38	135	19	25.5	89	57	121	48	4.4	135	CLM-34130-SHRB
CLM-34716-SHR	2200	M20	2.5	38	38	135	19	25.5	89	57	121	48	4.4	135	CLM-34131-SHRB
CLM-34101-SHR	3000	M20	2.5	28	52	187	25.5	35.5	129.5	71.5	168	71.5	4.6	135	CLM-34120-SHRB
CLM-34102-SHR	4200	M24	3	28	52	187	25.5	35.5	129.5	76	168	71.5	4.6	310	CLM-34121-SHRB
CLM-34103-SHR	4200	M24	3	38	52	187	25.5	35.5	129.5	76	168	71.5	4.6	310	CLM-34123-SHRB
CLM-34105-SHR	4500	M30	3.5	38	52	187	25.5	35.5	129.5	82	168	71.5	4.6	310	CLM-34126-SHRB
CLM-34107-SHR	4500	M30	3.5	48	52	187	25.5	35.5	129.5	82	168	71.5	4.6	310	CLM-34127-SHRB
CLM-34401-SHR	7000	M30	3.5	67	73	234	32	51	171.5	107.5	206	98.5	8.2	640	CLM-34421-SHRB
CLM-34402-SHR	11000	M36	4	67	73	234	32	51	171.5	114	206	98.5	8.2	1090	CLM-34422-SHRB
CLM-34403-SHR	12500	M42	4.5	80	73	234	32	51	171.5	114	206	98.5	8.2	1090	CLM-24232-SHRB
CLM-34404-SHR	13500	M48	5	80	73	234	32	51	171.5	114	206	98.5	8.2	1090	CLM-24225-SHRB

2



Optional Long-Ring Version

Long-ring version provides extra reach and allows using larger lifting hooks.

LONG RING (INCH)

PART NO.	LOAD RATING (LBS)	A	B	C	D	E DIA	F	G	K	L	N DIA	P	INSTALLATION TORQUE (FT-LBS)	REPLACEMENT BOLT (WITH RETAINING RING)
CL-33166-SHR	10000	1"-8	1.20	2.05	9.00	1.00	1.40	5.10	3.05	8.25	2.81	.18	230	CL-33126-SHRB
CL-33165-SHR			1.45											CL-33125-SHRB
CL-33167-SHR			2.20											CL-33127-SHRB

LONG RING (METRIC)

PART NO.	LOAD RATING (kg)	A THREAD	THREAD PITCH (mm)	B (mm)	C (mm)	D (mm)	E DIA (mm)	F (mm)	G (mm)	H (mm)	J (mm)	K (mm)	L (mm)	N DIA (mm)	P (mm)	INSTALLATION TORQUE (Nm)
CLM-29814-SHR-S	525	M12	1.75	19	31	171	19	22	83	51	89	43	157	38	4	19
CLM-29818-SHR-S	950	M16	2	24	31	171	19	22	83	51	89	47	157	38	4	41
CLM-29821-SHR-S	1100	M20	2.5	30	31	171	19	22	83	51	89	51	157	38	4	68
CLM-29823-SHR-S	1500	M20	2.5	29	43	206	25.5	36	121	76	131	64	187	60	6	68
CLM-29826-SHR-S	2100	M24	3	34	43	206	25.5	36	121	76	131	67	187	60	6	156
Please contact factory	2250	M30	3.5	54	43	206	25.5	36	121	76	131	73	187	60	6	320

SAFETY HOIST RINGS

RING: FORGED 4130 STEEL, HEAT TREATED, BLACK OXIDE FINISH, 100% MAGNAFLUX INSPECTED
 BASE: FORGED 1045 STEEL, BLACK OXIDE FINISH



Forged base rotates 360 degrees while the solid-loop forged ring pivots 180 degrees, to allow lifting from any direction. High-strength shoulder screw furnished. Safety factor = 5:1. Fasten hoist ring using the installation torque specified in the dimension table. Always install so that the hoist ring can pivot and swivel freely. **INFO+:** See general Hoist Ring Safety Precautions on page 74.

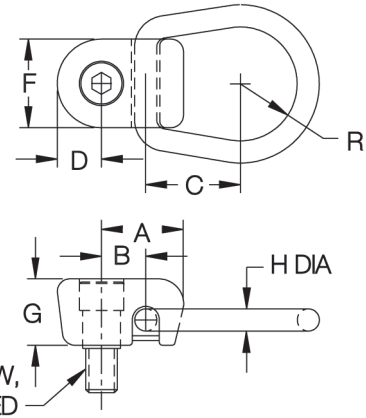

INCH

PART NO.	LOAD RATING (LBS)	A	B	C	D	F	G	H DIA	J	K	R	INSTALLTION TORQUE (FT-LBS)	REPLACEMENT SHOULDER SCREW
CL-10-SHR	1000	1-1/8	5/8	1-1/2	5/8	1-1/4	7/8	5/16	3/8-16	5/8	13/16	7-10	CL-10-SHRB
CL-25-SHR	2500	1-5/8	7/8	1-7/8	7/8	1-3/4	1-5/16	7/16	5/8-11	7/8	1-1/8	42-50	CL-25-SHRB

Your Source For Aerospace Tooling Components

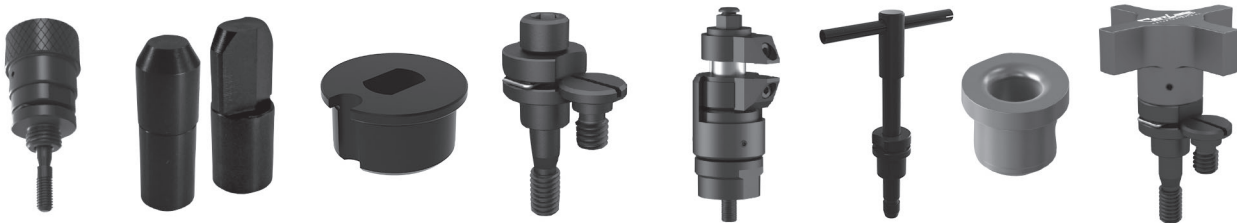

carrlane.com/aerospace-tooling

Go Lean With

CarrLock[®] System

2

Change from job
to job in seconds

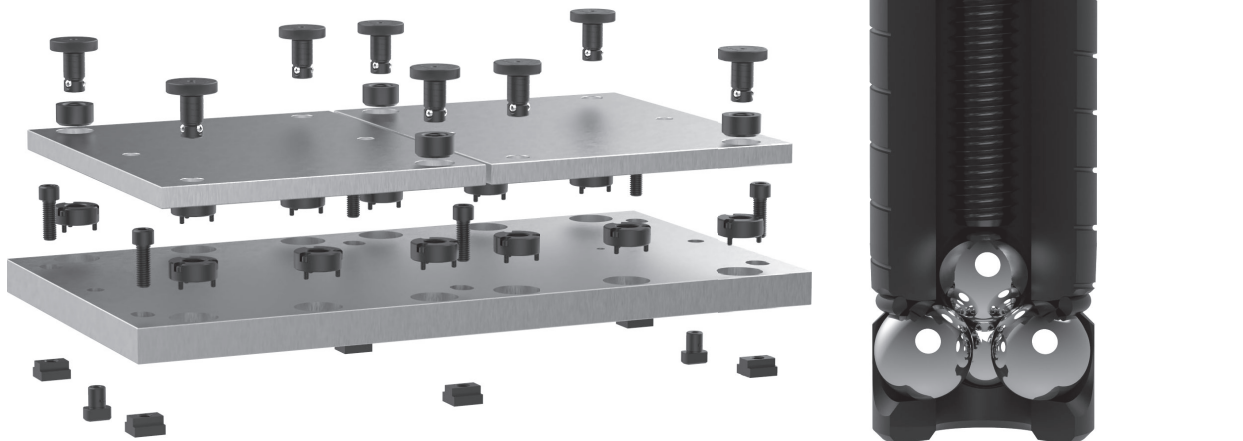

CarrLane[®]
M A N U F A C T U R I N G C O .

See page 355 for more information.

HEAVY-DUTY® SIDE-PULL HOIST RINGS

ALLOY STEEL, BLACK OXIDE FINISH, 100% MAGNAFLUX INSPECTED

2



D-Ring Type

Heavy-Duty version of our Side-Pull Hoist Rings offers greater load capacity in a given mounting-thread size. D-Ring type shown here is ideal for working with web slings. Side-Pull Hoist Rings are ideal for side mounting. Flip and turn loads without unhooking (use with a spreader bar). Forged alloy-steel ring pivots and swivels 360 degrees simultaneously to allow lifting from any direction. Safety factor = 5:1. **Patent no. 6,267,422.** Fasten hoist ring using the installation torque specified in the dimension table. Always install so that the hoist ring can pivot and swivel freely. **INFO+**: See general Hoist Ring Safety Precautions on page 74.

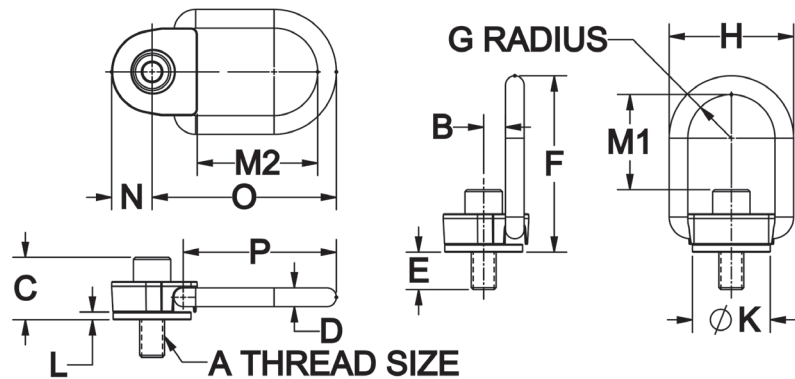

D-RING TYPE (INCH)

PART NO.	LOAD RATING (LBS)	A	B	C	D	E	F	G	H	K DIA	L	M1	M2	N	O	P	INSTALLTION TORQUE (FT-LBS)
CL-37305-SPHR	800	5/16-18		1.33		.48						3.18					7
CL-37310-SPHR	1000	3/8-16		1.40								3.12					12
CL-37315-SPHR	2500	1/2-13	.88	1.52	.50	.98	5.12	1.44	3.88	2.19	.23	2.99	3.43	1.25	5.48	4.61	28
CL-37320-SPHR	4000	5/8-11		1.65								2.87					60
CL-37325-SPHR	5000	3/4-10		1.77		1.23						2.74					100
CL-37330-SPHR	7000	3/4-10		2.22		1.28						3.76					100
CL-37335-SPHR	8000	7/8-9	1.25	2.35	.75	1.28	6.88	1.75	5.00	3.13	.31	3.63	4.34	1.62	7.40	6.15	160
CL-37340-SPHR	10000	1"-8		2.47		1.53						3.51					230

D-RING TYPE (METRIC)

PART NO.	LOAD RATING (kg)	A THREAD	THREAD PITCH (mm)	B (mm)	C (mm)	D (mm)	E (mm)	F (mm)	G (mm)	H (mm)	K DIA (mm)	L (mm)	M1 (mm)	M2 (mm)	N (mm)	O (mm)	P (mm)	INSTALLTION TORQUE (N-m)
CLM-37805-SPHR	400	M8	1.25		34		14						81					9.5
CLM-37810-SPHR	450	M10	1.5		36		24						16					
CLM-37815-SPHR	1050	M12	1.75	22	38	13	39	130	37	99	56	6	77	87	32	139	117	37
CLM-37820-SPHR	1900	M16	2		42		39						73					80
CLM-37825-SPHR	2200	M20	2.5		46		39						69					135
CLM-37830-SPHR	3000	M20	2.5	32	57	19	38	175	44	127	79	8	94	110	41	188	156	135
CLM-37835-SPHR	4200	M24	3		61		43						90					311

HEAVY-DUTY® SIDE-PULL HOIST RINGS

ALLOY STEEL, BLACK OXIDE FINISH, 100% MAGNAFLUX INSPECTED



Triangular-Ring Type

Heavy-Duty version of our Side-Pull Hoist Rings offers greater load capacity in a given mounting-size. Side-Pull Hoist Rings are ideal for side mounting. Flip and turn loads without unhooking (use with a spreader bar). Forged alloy-steel ring pivots and swivels 360 degrees simultaneously to allow lifting from any direction. Safety factor = 5:1. **Patent no. 6,267,422.** Fasten hoist ring using the installation torque specified in the dimension table. Always install so that the hoist ring can pivot and swivel freely. **INFO+:** See general Hoist Ring Safety Precautions on page 74.

2

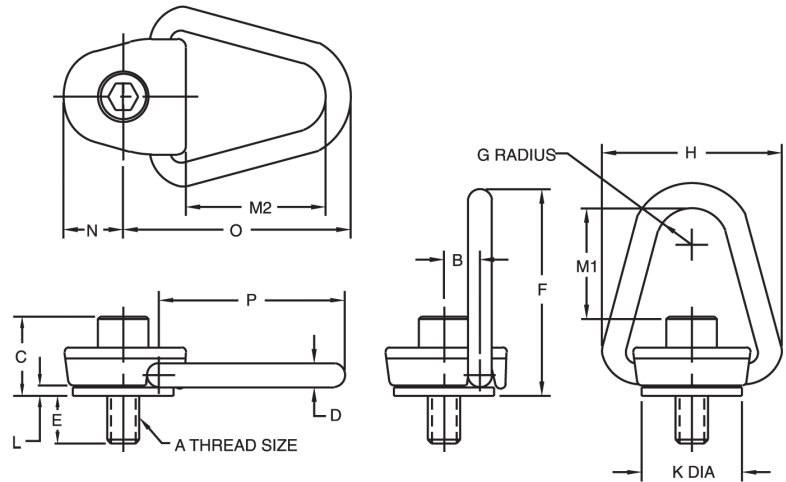

TRIANGULAR-RING TYPE (INCH)

PART NO.	LOAD RATING (LBS)	A	B	C	D	E	F	G	H	K DIA	L	M1	M2	N	O	P	INSTALLATION TORQUE (FT-LBS)
CL-36305-SPHR	800	5/16-18	.88	1.33	.50	.48	4.72	.75	3.88	2.19	.22	2.89	3.19	1.25	5.12	4.25	7
CL-36310-SPHR	1000	3/8-16		1.39		2.84						12					
CL-36315-SPHR	2500	1/2-13	.88	1.53	.50	.98	4.72	.75	3.88	2.19	.22	2.70	3.19	1.25	5.12	4.25	28
CL-36320-SPHR	4000	5/8-11		1.64		2.92						60					
CL-36325-SPHR	5000	3/4-10	.88	1.78	.50	1.23	4.72	.75	3.88	2.19	.22	2.94	3.19	1.25	5.12	4.25	100
CL-36330-SPHR	7000	3/4-10		2.12		4.00						100					
CL-36340-SPHR	10000	1"-8	1.25	2.38	.75	1.50	6.25	.88	5.25	3.25	.25	3.75	4.19	1.62	6.75	5.62	230

TRIANGULAR-RING TYPE (METRIC)

PART NO.	LOAD RATING (kg)	A THREAD	THREAD PITCH (mm)	B (mm)	C (mm)	D (mm)	E (mm)	F (mm)	G (mm)	H (mm)	K DIA (mm)	L (mm)	M1 (mm)	M2 (mm)	N (mm)	O (mm)	P (mm)	INSTALLATION TORQUE (N-m)
CLM-36805-SPHR	400	M8	1.25	22	34	13	14	121	19	98	56	6	74	81	32	130	108	9.5
CLM-36810-SPHR	450	M10	1.5		36		24						16					
CLM-36815-SPHR	1050	M12	1.75	22	38	13	39	121	19	98	56	6	70	81	32	130	108	37
CLM-36820-SPHR	1900	M16	2		42		39						80					

PIVOTING HOIST RINGS

RING: FORGED 4130 STEEL, HEAT TREATED, BLACK OXIDE FINISH, 100% MAGNAFLUX INSPECTED PER ASTM E-1444
 BASE: FORGED 1045 STEEL, BLACK OXIDE FINISH

2



Economical hoist ring with a low profile and high load capacity. Forged base and solid-loop forged ring. Pivots a full 180 degrees, but does not rotate (install so that lifting force is applied in the pivoting direction). Safety factor = 5:1. Fasten hoist ring with grade-8 Socket-Head Cap Screws, using the installation torque specified in the dimension table. The smallest three sizes have two mounting holes, the largest two sizes have four. **INFO+**: See general Hoist Ring Safety Precautions on page 74.

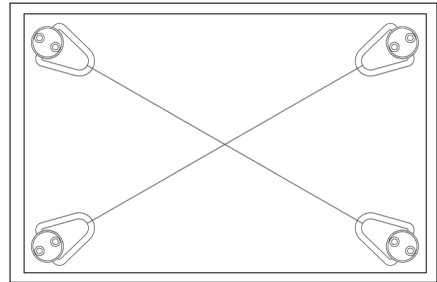

Install hoist rings so that lifting force is applied in the pivoting direction.

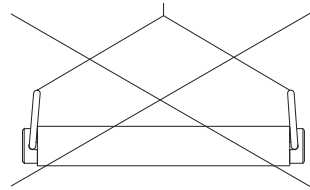

BAD

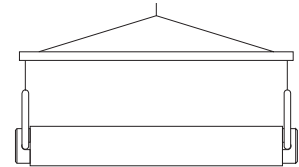

GOOD

Do not allow hoist rings to bind. Use a spreader bar, if necessary, to avoid binding.

FOR D SOCKET-HEAD
 CAP SCREWS (2 OR 4,
 DEPENDING ON SIZE)

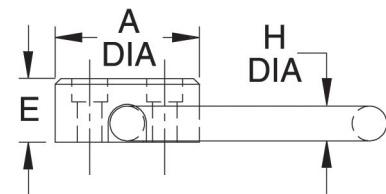
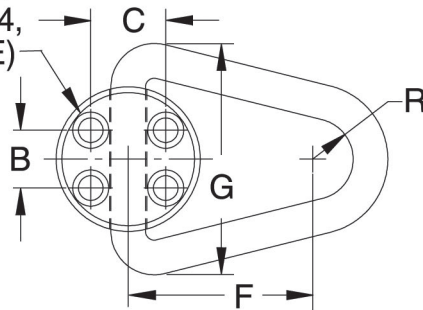

PART NO.	LOAD RATING (LBS)	A DIA	B	C	D THREAD X MIN. LENGTH	E DIA	F	G	H DIA	R	INSTALLATION TORQUE (FT-LBS)	SCREW EXTENSION BELOW BASE
CL-20-HR	2000	1-3/4	0	1	5/16-18x1.00 (or M8x25mm)	3/4	2	2-1/2	5/16	1/2	4-7	.58 (or 14mm)
CL-25-HR	2500	2-1/4		1-1/8	3/8-16x1.25 (or M10x30mm)	7/8	2-1/2	3-3/16	3/8	5/8	7-10	.79 (or 18mm)
CL-50-HR	5000	2-5/8		1-1/2	1/2-13x1.50 (or M12x40mm)	1-1/8	3	3-7/8	1/2	3/4	20-25	.90 (or 25mm)
CL-120-HR	12000	3-1/8	1-1/4	1-5/8	1/2-13x1.75 (or M12x45mm)	1-3/8	4	5	3/4	7/8	20-25	.90 (or 23mm)
CL-200-HR	20000	3-5/8		2-1/16	5/8-11x2.50 (or M16x65mm)	1-7/8	5	6-3/16	1	1	42-50	1.25 (or 33mm)

LIFTING EYES

STEEL: FORGED CARBON STEEL, QUENCHED AND DRAWN, PLAIN FINISH
 STAINLESS STEEL: FORGED 316 STAINLESS STEEL, PASSIVATED AND ELECTROPOLISHED

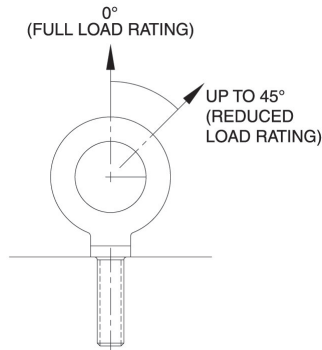

Angular lifting at up to 45° is allowable in this direction (plane of the eye) but load rating is reduced.

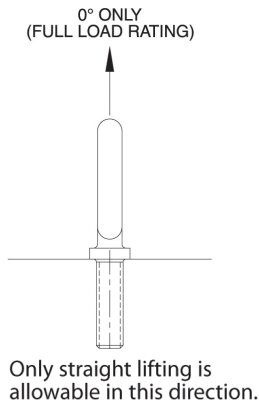
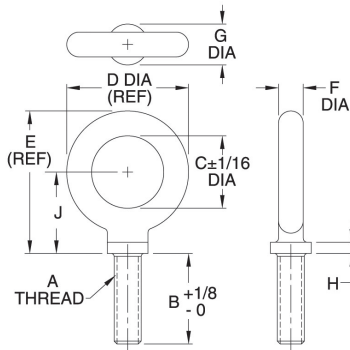

Lifting Eyes are forged steel eyebolts with an integral shoulder for greater strength. These simple, economical lifting devices are suitable for vertical lifting in-line with the threaded bolt, such as when lifting from a single point or from two points with a spreader bar. For lifting at an angle, Swivel Hoist Rings should be used instead. Manufactured and tested according to ASTM A489 and ANSI B18.15 specifications. Safety factor = 5:1. Made in USA.

Lifting Eyes should be inspected before each use for possible defects and installed by a person trained in the installation of lifting devices. The tapped receiving hole should be countersunk, free of any debris, and deep enough to ensure proper shoulder seating. Firm hand tightening is recommended for installation; do not use wrenches or bars. Angular lifting should be avoided, because angular lifts significantly reduce rated capacity. Any angular loads must be radial in the plane of the eye, never at an angle to that plane. A steel washer or shim may be used under the shoulder to achieve proper eye orientation, but its thickness should not exceed one thread pitch. A washer may also be required to ensure flush seating on rough mounting surfaces.

Do not exceed rated load capacity. Maximum load rating applies to straight vertical lifting only. Lifting at an angle reduces load rating significantly – see table below for reduced load rating at 45° (this reduced rating should be used for any lift other than at 0° vertical). Do not work, stand, or crawl near the load of a Lifting Eye. Do not use a Lifting Eye to lift a load that can rotate; Swivel Hoist Rings should be used for such loads. Do not shock load Lifting Eyes; instead gradually increase lifting of the load to minimize load shock. Do not force hooks or any other fittings into the eye; they must fit freely. Do not weld or machine Lifting Eyes, or perform any repair. Do not expose Lifting Eyes to extreme temperatures or environmental conditions, as this may permanently reduce load capacity. Periodic inspection of installed Lifting Eyes is highly recommended. **INFO+** Also see general Hoist Ring Safety Precautions on page 74.

STEEL (INCH)

PART NO.	A THREAD	B	C DIA	D DIA	E	F DIA	G DIA	H	J	LOAD RATING (lbs)	
										0°	45°
CL-4-LE	1/4-20	1	3/4	1-3/16	1-11/32	7/32	17/32	5/32	3/4	500	125
CL-5-LE	5/16-18	1-1/8	7/8	1-7/16	1-21/32	9/32	19/32	5/32	15/16	900	225
CL-6-LE	3/8-16	1-1/4	1	1-11/16	1-31/32	11/32	21/32	5/32	1-1/8	1300	325
CL-8-LE	1/2-13	1-1/2	1-3/16	2-1/8	2-7/16	15/32	29/32	7/32	1-3/8	2400	600
CL-10-LE	5/8-11	1-3/4	1-3/8	2-9/16	2-15/16	19/32	1-1/32	9/32	1-21/32	4000	1000
CL-12-LE	3/4-10	2	1-1/2	2-13/16	3-7/32	21/32	1-3/16	9/32	1-13/16	5000	1250
CL-16-LE	1"-8	2-1/2	1-3/4	3-19/16	4-3/32	29/32	1-9/16	13/32	2-5/16	9000	2250

STAINLESS STEEL (INCH)

CL-4-LE-316S	1/4-20	1	3/4	1-3/16	1-11/32	7/32	17/32	5/32	3/4	500	125
CL-5-LE-316S	5/16-18	1-1/8	7/8	1-7/16	1-21/32	9/32	19/32	5/32	15/16	900	225
CL-6-LE-316S	3/8-16	1-1/4	1	1-11/16	1-31/32	11/32	21/32	5/32	1-1/8	1300	325
CL-8-LE-316S	1/2-13	1-1/2	1-3/16	2-1/8	2-7/16	15/32	29/32	7/32	1-3/8	2400	600
CL-10-LE-316S	5/8-11	1-3/4	1-3/8	2-9/16	2-15/16	19/32	1-1/32	9/32	1-21/32	4000	1000

STEEL (METRIC)

PART NO.	A THREAD	THREAD PITCH (mm)	B (mm)	C DIA (mm)	D DIA (mm)	E (mm)	F DIA (mm)	G DIA (mm)	H (mm)	J (mm)	LOAD RATING (kg)	
											0°	45°
CLM-6-LE	M6	1	25.4	19	30	34	5.5	14	4	19	210	50
CLM-8-LE	M8	1.25	31.5	25	43	48	9	17	4	26	500	125
CLM-10-LE	M10	1.5	35	27	46	55	9.5	20	4	32	740	185
CLM-12-LE	M12	1.75	38	30	54	62	12	23	5.5	35	1030	255
CLM-16-LE	M16	2	44.5	35	65	76	15	26	7	44	1600	400

HOIST EYE 360°

BODY: HIGH-STRENGTH FORGED ALLOY STEEL, HIGH-VISIBILITY POWDER-COAT FINISH
 BOLT: HIGH-STRENGTH ALLOY STEEL, CORROSION-RESISTANT PLATING
 RETAINING RING: SPRING STEEL

2

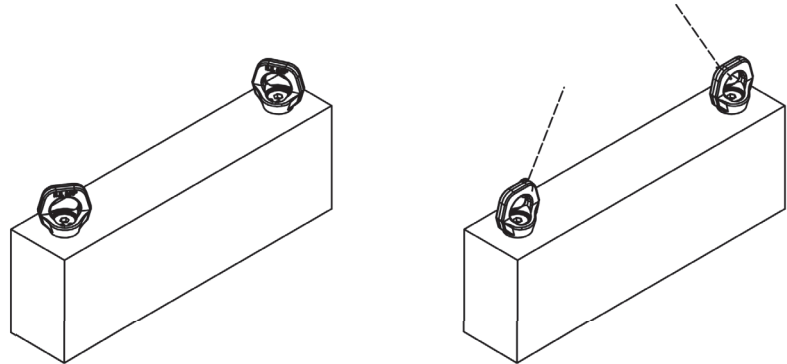

These unique lifting-eye assemblies can be rotated freely after installation, to align with the pulling direction.

New item!

Hoist Eye 360° is a forged lifting eye that can be rotated 360° after installation, to align with the pulling direction. This compact assembly features a specially designed shoulder bolt, which rotates freely in the precisely machined lifting-eye body and is held captive by a retaining ring. Unlike conventional lifting eyes, Hoist Eye 360° can be used at full rated load capacity when pulling at any angle 0 to 90° from the bolt axis. Available with thread sizes from 3/8-16 to 1"-8. Complies with ASME B30.26 specifications. 200% proof load tested and individually serialized. Safety factor = 5:1. Made in USA.

Please note, Hoist Eye 360° is suitable only for applications where all lifting-eye rotation takes place before lifting begins, with no swivel action occurring while under load. For applications that require swiveling under load, use a Swivel Hoist Ring instead. An installation key is provided to allow firm tightening by hand, which is allowable for one-time temporary lifting. For permanent installation, tighten by hex wrench to the installation torque listed in the tables below.

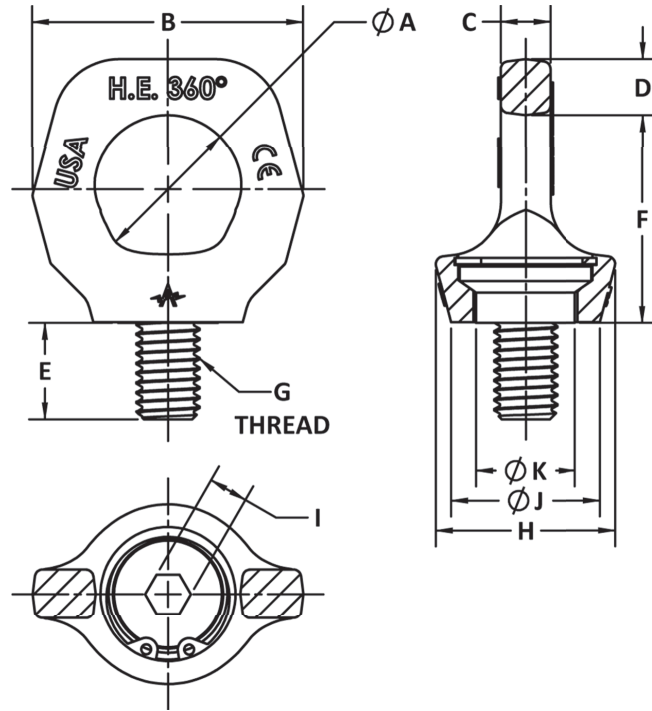

INCH

PART NO.	LOAD RATING (lbs)	G THREAD	A DIA	B	C	D	E	F	H	I HEX	J DIA	K DIA	INSTALLATION TORQUE (ft-lbs)
CL-71120-HE	880	3/8-16	.96	1.81	.36	.37	.61	1.40	1.19	7/32	1.00	.59	12
CL-71146-HE	1650	1/2-13	1.16	2.14	.39	.44	.76	1.64	1.42	5/16	1.18	.79	28
CL-71160-HE	3000	5/8-11	1.30	2.55	.55	.50	.94	1.94	1.69	3/8	1.38	.94	47
CL-71174-HE	4500	3/4-10	1.50	2.95	.63	.59	1.18	2.30	2.00	1/2	1.65	1.14	84
CL-71198-HE	7050	1"-8	1.84	3.53	.75	.72	1.5	2.82	2.35	5/8	1.97	1.34	230

METRIC

PART NO.	LOAD RATING (kg)	G THREAD	THREAD PITCH	A DIA (mm)	B (mm)	C (mm)	D (mm)	E (mm)	F (mm)	H (mm)	I HEX (mm)	J DIA (mm)	K DIA (mm)	INSTALLATION TORQUE (Nm)
CLM-71420-HE	400	M10	1.5	24	46	9	9	15	36	30	6	25.4	15	16
CLM-71446-HE	750	M12	1.75	29	54	10	11	19	42	36	8	30	20	38
CLM-71460-HE	1400	M16	2.0	33	65	14	13	24	49	43	10	36	23.7	64
CLM-71474-HE	2000	M20	2.5	38	75	16	15	30	58	51	12	42	28	114

HOIST RING ACCESSORIES



Forged Anchor Shackles

High-strength forged alloy-steel anchor shackle. Supplied with thin-head bolt and nut with cotter pin. Meets Federal Specification RR-C 271D, Type IVA, Grade A, Class 3. Safety factor = 6:1. Heat treated with black oxide finish. INFO+: See general Hoist Ring Safety Precautions on page 74.

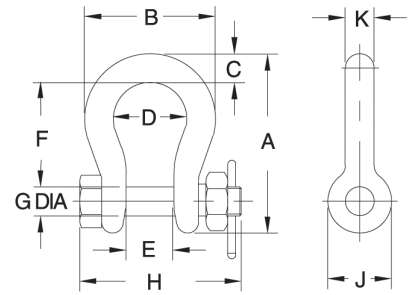

FORGED ANCHOR SHACKLES (INCH)

PART NO.	LOAD RATING (LBS)	NOMINAL SHACKLE SIZE	A	B	C	D	E	F	G DIA.	H	J	K
CL-36511-FAS	2000	3/8	2.49	1.78	.38	1.03	.66	1.44	.44	2.17	.91	3/8
CL-36521-FAS	3000	7/16	2.91	2.03	.44	1.16	.75	1.69	.50	2.51	1.06	7/16
CL-36531-FAS	4000	1/2	3.28	2.31	.50	1.31	.81	1.88	.63	2.80	1.19	1/2
CL-36541-FAS	6500	5/8	4.19	2.94	.69	1.69	1.06	2.38	.75	3.53	1.50	5/8
CL-36551-FAS	13000	7/8	5.83	4.03	.97	2.28	1.44	3.31	1.00	4.71	2.09	7/8
CL-36561-FAS	19000	1-1/8	7.47	5.16	1.25	2.91	1.81	4.25	1.25	5.09	2.69	1-1/8
CL-36571-FAS	24000	1-1/4	8.25	5.75	1.38	3.25	2.03	4.69	1.38	6.51	3.00	1-1/4



Forged Rings

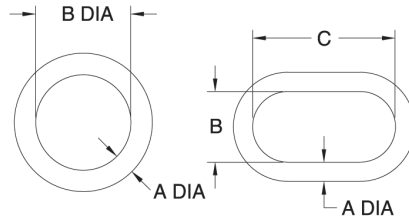

High-strength weldless forged alloy-steel ring. Safety factor = 6:1. Heat treated with black oxide finish. INFO+: See general Hoist Ring Safety Precautions on page 74.

FORGED RINGS

PART NO.	LOAD RATING (LBS)	A DIA.	B DIA.	C
CL-36111-FR	3800	3/8	2	—
CL-36121-FR	6100	5/8	3	—



Hoist-Ring Clips

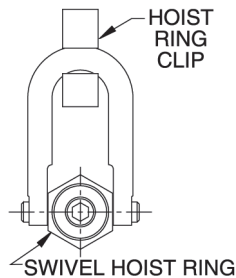

Handy holddown clip to keep Swivel Hoist Rings and Side-Pull Hoist Rings from rotating when not in use. Spring steel, zinc plated. Available in two sizes, one fitting ring diameters from 3/8" to 5/8", the other fitting ring diameters from 3/4" to 1-1/16".

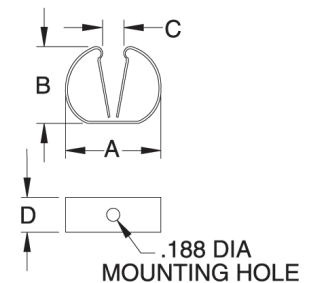

HOIST-RING CLIPS

PART NO.	FITS RING DIAMETER	A	B	C	D
CL-1-HRC	3/8, 7/16, 5/8	1-3/8	15/16	5/16	1/2
CL-2-HRC	3/4, 1-1/16	1-5/8	1-1/4	3/4	5/8

HOIST RINGS

2

AVAILABLE EXCLUSIVELY ONLINE AT WWW.CARRLANE.COM

The following hoist ring selections may be found online in the product catalog at carrlane.com



FORGED ROAD-PLATE SWIVEL HOIST RINGS*

These hoist rings have a shorter, larger-diameter bolt, ideal for lifting heavy plates. **Patent no. 4,570,987, no. 4,641,986, no. 5,405,210** and others pending.



FORGED BAR-TITE™ SWIVEL HOIST RINGS*

These hoist rings have a steel bar knob for tightening with a level bar instead of a wrench. **Patent no. 4,570,987, no. 4,641,986, no. 5,405,210** and others pending.



FORGED SPIN-N-LOK™ SWIVEL HOIST RINGS*

These hoist rings have a spoked lug nut for tightening without a wrench. **Patent no. 4,570,987, 4,641,986, 5,405,210** and other patents pending.



FORGED WELD-MOUNT SWIVEL HOIST RINGS*

These hoist rings mounted by welding. **Patent no. 4,570,987, no. 4,641,986, no. 5,405,210** and others pending.



HEAVY-DUTY SUPER-COIL™ SWIVEL HOIST RINGS*

These hoist rings are furnished with a coil bolt, and are ideal for temporary attachment to steel structures and construction material. **Patent no. 4,570,987, 4,641,986, 5,405,210, 5,732,991**, and others pending.



FORGED SWIVEL LIFT PLATES

These swivel hoist rings have a center through-hole instead of a bolt, for mounting with a custom anchoring system. **Patent no. 4,570,987, no. 4,641,986, no. 5,405,210** and others pending.



SHACKLE HOIST RINGS*

These swivel hoist rings are designed for permanent mounting on tooling and equipment. Forged alloy-steel shackle pivots 180 degrees and swivels 360 degrees simultaneously to allow lifting from any direction. **Patent no. 5,823,588.**



FAST-LOK™ PLATE LIFTING SYSTEM

Plate-lifting system with a weld-on base and totally removable shackle assembly, allowing the plate surface to remain totally free of obstructions. Patent pending. FEATURES: Fast-Lok™ Clevis, Fast-Lok™ Base, Forged Anchor Shackle, Fast-Lok™ Detent Pin.



SCISSOR-LOK™ PLATE LIFTING SYSTEM

Plate-lifting system with a weld-on base and totally removable shackle assembly, allowing the plate surface to remain total free of obstructions. Patent pending, FEATURES: Scissor-Lok™ Tool, Fast-Lok™ Base, Forged Anchor Shackle, and Fast-Lok™ Detent Pin.



UNIVERSAL LIFTING RINGS

Removable hoist rings with a forged alloy-steel shackle. Each Universal Lifting Ring fits three different thread sizes. Designed for straight vertical lifting only. **Patent no. 4,557,513.**

HOIST RING ACCESSORIES — AVAILABLE EXCLUSIVELY ONLINE:



RENEWAL ROAD PLATES ROUND



RENEWAL ROAD PLATES SQUARE

*Forged alloy-steel shackle pivots 180 degrees and swivels 360 degrees simultaneously to allow lifting from any direction.

HANDLES, KNOBS & SCREW CLAMPS



Fluted Knobs



Four-Prong Knobs & Screw Clamps



Three-Prong Knobs



T-Handle Knobs



Bar-Handle Knobs & Screw Clamps



Knurled Knobs & Screw Clamps



Socket-Head Screw Clamps



Feet for Swivel Screws



Latch Screws



Hand Wheels



Solid Handles



Revolving Handles



Lever Handles & Crank Handles



Adjustable Lever Handles



Knob Handles







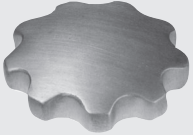

Pull Handles

HAND KNOBS



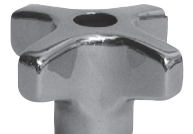



TYPES

3

		MADE IN THE USA	ALUMINUM	STEEL	CAST IRON	STAINLESS STEEL	PLASTIC
	PALM-GRIP HAND KNOBS Polished full-grip hand knob. Choose from two sizes, each available blank, tapped, or reamed.	X	X				
	FLUTED KNOBS Large easy-grip knob that is excellent for either fine adjustment or high-torque applications.	X					X
	STAR KNOBS Five lobes provide a firm, sure grip for applications requiring quick tightening and high torque.	X					X
	HAND KNOBS – CAST IRON Classic easy-to-grip clamping knob. Choose from five sizes, each available blank, tapped, tapped through, or reamed.	X			X		
	HAND KNOBS – ALUMINUM Classic easy-to-grip clamping knob. Choose from five sizes, each available blank, tapped, tapped through, or reamed.	X	X				
	HAND KNOBS – STAINLESS STEEL High-quality beautiful polished finish. Four-prong design provides a firm grip for applications requiring quick tightening and high torque.					X	
	HAND KNOB ASSEMBLIES Classic, easy-to-grip aluminum knob with an integral steel clamping screw.	X	X				

HAND KNOBS

TYPES

		MADE IN THE USA	ALUMINUM	STEEL	CAST IRON	STAINLESS STEEL	PLASTIC
	SWIVEL-WASHER HAND KNOB ASSEMBLIES Hand-knob assembly with a captive, freely rotating washer to prevent marring in clamping applications. Now available with a choice of steel or nylon washer.	X	X				
	KNOB SHOE ASSEMBLIES Features an integral steel clamping screw with a removable swivel foot. Uses our patented left-hand-thread swivel foot system.	X	X				
	FOUR PRONG KNOBS Design provides a strong grip for clamping and other applications requiring quick tightening and high torque.	X					X
	QUICK-ACTING KNOBS Slides in and out of clamping position quickly; ideal when the knob must be completely removed for loading.	X			X		
	BAR KNOBS Heavy-duty knob that can be turned easily by hand, then tightened by inserting a bar between the prongs.	X				X	
	THREE-PRONG KNOBS Modern design provides quick tightening and high torque. Textured non-slip, non-glare finish.	X					X
	T-HANDLE KNOBS Provides maximum leverage for heavy-duty clamping.	X					

PALM-GRIP HAND KNOBS

319 ALUMINUM ALLOY

3



1/2-13
5/8-11
M12
M16



3/8-16
1/2-13
M10
M12

Polished full-grip hand knob. Choose from two knob sizes, each available blank, tapped or reamed.

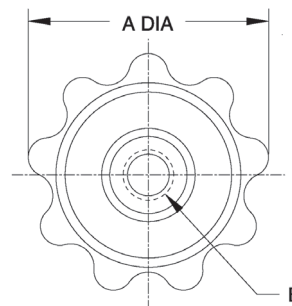
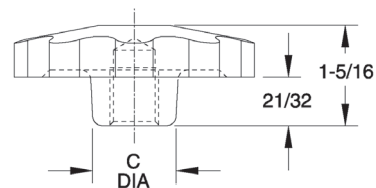

Blank



Tapped



Reamed

INCH & METRIC

PART NO.	A DIA	C DIA	HOLE TYPE	B		
CL-11-PHK	2-3/4	1	BLANK	—		
CL-13-PHK			TAPPED	3/8-16 X 3/4 DEEP		
CL-14-PHK				1/2-13 X 3/4 DEEP		
CLM-13-PHK				M10 X 3/4 DEEP		
CLM-14-PHK				M12 X 3/4 DEEP		
CL-12-PHK				3/8 X 7/8 DEEP		
CL-15-PHK				1/2 X 7/8 DEEP		
CLM-12-PHK			REAMED	10mm X 7/8 DEEP		
CLM-15-PHK				12mm X 7/8 DEEP		
CL-21-PHK				—		
CL-23-PHK			3-1/8	1	BLANK	—
CL-24-PHK					TAPPED	1/2-13 X 3/4 DEEP
CLM-23-PHK	5/8-11 X 3/4 DEEP					
CLM-24-PHK	M12 X 3/4 DEEP					
CL-22-PHK	M16 X 3/4 DEEP					
CL-25-PHK	1/2 X 7/8 DEEP					
CLM-22-PHK	5/8 X 1 DEEP					
CLM-25-PHK	REAMED	12mm X 7/8 DEEP				
		16mm X 1 DEEP				

FLUTED KNOBS

BLACK PHENOLIC PLASTIC OR THERMOPLASTIC WITH BRASS INSERT



Large easy-grip knob that is excellent for either fine-adjustment or high-torque applications. Molded-in brass insert provides superior thread strength. Choice of four knob sizes. Non-standard thread sizes, reamed holes, or molded-in studs are available in quantities of 500 and above.

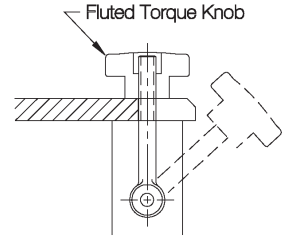

3

Phenolic — Tapped Through Hole

Phenolic — Tapped Short Hub

1/2-13 CL-88-PFK
5/8-11 CL-810-PFK



3/8-16 CL-66-PFK
1/2-13 CL-68-PFK
M12 CLM-612-PFK



3/8-16 CL-660-PFK



3/8-16 CL-666-PFK



3/8-16 CL-466-PFK



1/4-20 CL-44-PFK
5/16-18 CL-45-PFK
3/8-16 CL-46-PFK
M8 CLM-48-PFK
M10 CLM-410-PFK



5/16-18 CL-450-PFK

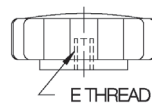
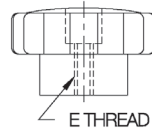
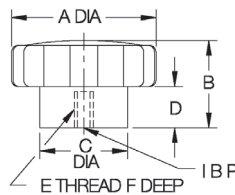

#10-32 CL-23-PFK
1/4-20 CL-24-PFK
5/16-18 CL-25-PFK
M6 CLM-26-PFK

PHENOLIC — TAPPED (INCH & METRIC)

PART NO.	A DIA	B	C DIA	D	E	F
CL-23-PFK	1-3/8	27/32	27/32	25/64	#10-32	5/16
CL-24-PFK					1/4-20	7/16
CL-25-PFK					5/16-18	
CLM-26-PFK					M6	
CL-44-PFK	1-3/4	1-1/16	1-1/16	1/2	1/4-20	1/2
CL-45-PFK					5/16-18	
CL-46-PFK					3/8-16	
CLM-48-PFK					M8	7/16
CLM-410-PFK					M10	
CL-66-PFK	2-3/8	1-5/16	1-1/4	5/8	3/8-16	1/2
CL-68-PFK					1/2-13	5/8
CLM-612-PFK					M12	
CL-88-PFK					1/2-13	
CL-810-PFK	3-1/4	1-25/32	2	7/8	5/8-11	3/4

PHENOLIC — TAPPED THROUGH HOLE (INCH)

CL-450-PFK	1-3/4	61/64	1-1/16	1/2	5/16-18	5/8
CL-660-PFK	2-3/8	1-9/32	1-1/4	5/8	3/8-16	5/8

PHENOLIC — TAPPED, SHORT HUB (INCH)

CL-466-PFK	1-3/4	11/16	3/4	1/8	3/8-16	3/8
CL-666-PFK	2-3/8	13/16	3/4	1/8	3/8-16	1/2

FLUTED KNOBS

BLACK THERMOPLASTIC OR PHENOLIC PLASTIC WITH BRASS INSERT

Thermoplastic — Tapped



5/16-18 CL-750-PFK
3/8-16 CL-760-PFK



5/16-18 CL-550-PFK
3/8-16 CL-560-PFK

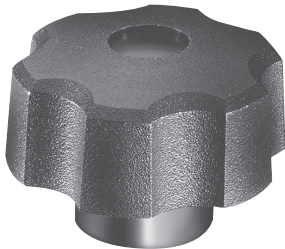

1/4-20 CL-340-PFK
5/16-18 CL-350-PFK

Thermoplastic version of the Fluted Knobs with a textured non-slip, non-glare finish. Choice of three knob sizes. Molded-in brass insert provides superior thread strength. Non-standard thread sizes, reamed holes, molded-in studs, or special colors are available in quantities of 500 and above.

Thermoplastic — Tapped Through Hole

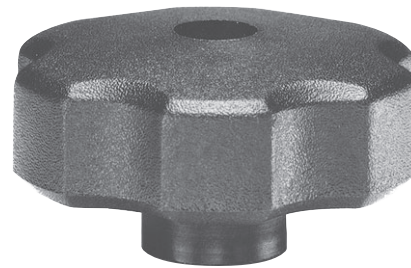

5/16-18 CL-551-PFK
3/8-16 CL-561-PFK



1/4-20 CL-341-PFK
5/16-18 CL-351-PFK

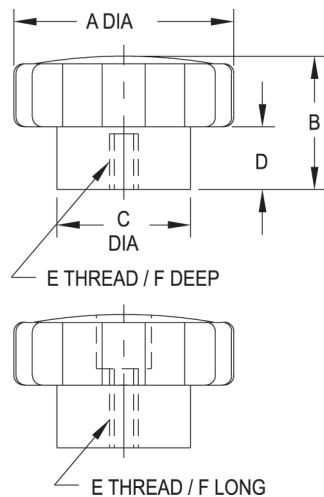

THERMOPLASTIC — TAPPED

PART NO.	A DIA	B	C DIA	D	E	F
CL-340-PFK	1-1/2	1	3/4	3/8	1/4-20	5/8
CL-350-PFK					5/16-18	
CL-550-PFK	2-5/32	1-1/8	3/4	3/8	5/16-18	3/4
CL-560-PFK					3/8-16	
CL-750-PFK	3-1/4	1-5/8	2	3/4	5/16-18	3/4
CL-760-PFK					3/8-16	

THERMOPLASTIC — TAPPED THROUGH HOLE

CL-341-PFK	1-1/2	1	3/4	3/8	1/4-20	5/8
CL-351-PFK					5/16-18	
CL-551-PFK	2-5/32	1-1/8	3/4	3/8	5/16-18	7/8
CL-561-PFK					3/8-16	

STAR KNOBS

BLACK THERMOPLASTIC OR CUSHION-GRIP PLASTIC WITH BRASS INSERT

Thermoplastic — Tapped



1/4-20 CL-632-SK
5/16-18 CL-642-SK
3/8-16 CL-652-SK

Thermoplastic — Tapped Through Hole



1/4-20 CL-636-SK
5/16-18 CL-646-SK
3/8-16 CL-656-SK

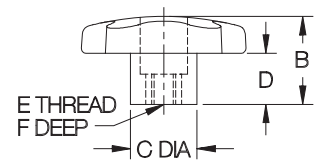
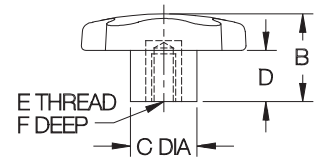
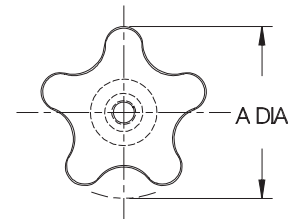

Cushion Grip — Tapped



5/16-18 CL-755-SK
3/8-16 CL-765-SK



1/4-20 CL-545-SK
5/16-18 CL-555-SK
3/8-16 CL-565-SK



1/4-20 CL-345-SK
5/16-18 CL-355-SK

Star Knobs have five lobes to provide a firm, sure grip for applications requiring quick tightening and high torque. Smooth, rounded lobes prevent snagging. Thermoplastic version has a textured, non-slip, non-glare finish. Cushion-Grip version is made from a unique material that feels soft to the touch, comfortable yet rugged. Molded-in brass insert provides superior thread strength. Non-standard thread sizes, reamed holes, molded-in studs, or special colors are available in quantities of 500 and above.

THERMOPLASTIC — TAPPED

PART NO.	A DIA	B	C DIA	D	E	F
CL-632-SK	2-1/4	1	7/8	1/2	1/4-20	1/2
CL-642-SK					5/16-18	5/8
CL-652-SK					3/8-16	1/2

THERMOPLASTIC — TAPPED THROUGH HOLE

PART NO.	A DIA	B	C DIA	D	E	F
CL-636-SK	2-1/4	1	7/8	1/2	1/4-20	5/8
CL-646-SK					5/16-18	
CL-656-SK					3/8-16	

CUSHION GRIP — TAPPED

PART NO.	A DIA	B	C DIA	D	E	F
CL-345-SK	1-1/2	1-3/32	11/16	15/64	1/4-20	5/8
CL-355-SK					5/16-18	
CL-545-SK	2	1-3/8	3/4	33/64	1/4-20	5/8
CL-555-SK					5/16-18	
CL-565-SK					3/8-16	
CL-755-SK	2-3/8	1-5/8	3/4	11/16	5/16-18	5/8
CL-765-SK					3/8-16	

HAND KNOBS

CAST IRON, ZINC PLATED CLEAR CHROMATE

Cast Iron

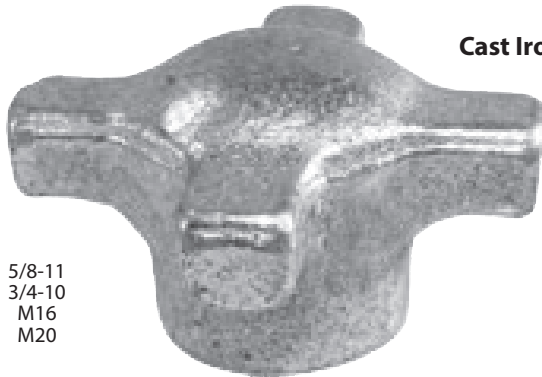

5/8-11
3/4-10
M16
M20

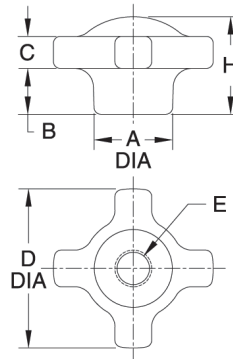

Classic easy-to-grip clamping knob, available in cast iron (shown here) or aluminum. Choose from five cast iron knob sizes, available blank, tapped, or tapped through.



1/2-13
5/8-11
M12
M16

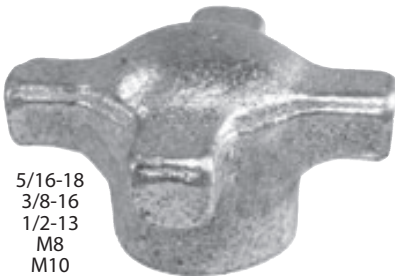

5/16-18
3/8-16
1/2-13
M8
M10
M12



1/4-20
5/16-18
M6
M8

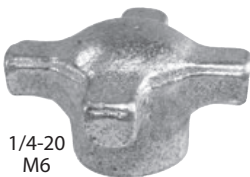

1/4-20
M6

CAST IRON (INCH & METRIC)

PART NO. CAST IRON	D DIA	A DIA	B	C	H	HOLE TYPE	E
CL-85-HK-8	1-1/8	9/16	5/16	5/16	7/8	BLANK	—
CL-80-HK-8						TAPPED	1/4-20 x 1/2 DEEP
CLM-80-HK-8						TAPPED	M6 x 1/2 DEEP
CL-8-HK-8						TAPPED THROUGH	1/4-20
CLM-8-HK-8	1-3/4	3/4	1/2	3/8	1-1/8	TAPPED	M6
CL-25-HK-2						BLANK	—
CL-10-HK-2						TAPPED	1/4-20 x 7/8 DEEP
CL-20-HK-2						TAPPED	5/16-18 x 7/8 DEEP
CLM-10-HK-2	2-1/8	1	5/8	7/16	1-3/8	TAPPED	M6 x 7/8 DEEP
CLM-20-HK-2						TAPPED	M8 x 7/8 DEEP
CL-1-HK-2						TAPPED THROUGH	1/4-20
CL-2-HK-2						TAPPED THROUGH	5/16-18
CLM-1-HK-2	2-1/2	1-1/8	1	1/2	1-5/8	TAPPED	M6
CLM-2-HK-2						TAPPED	M8
CL-45-HK-4						BLANK	—
CL-20-HK-4						TAPPED	5/16-18 x 1 DEEP
CL-30-HK-4	2-3/4	1-3/8	3/4	1/2	1-1/2	TAPPED	3/8-16 x 1 DEEP
CL-40-HK-4						TAPPED	1/2-13 x 1 DEEP
CLM-20-HK-4						TAPPED	M8 x 1 DEEP
CLM-30-HK-4						TAPPED	M10 x 1 DEEP
CLM-40-HK-4	2-3/4	1-3/8	3/4	1/2	1-1/2	TAPPED	M12 x 1 DEEP
CL-2-HK-4						TAPPED	5/16-18
CL-3-HK-4						TAPPED	3/8-16
CL-4-HK-4						TAPPED	1/2-13
CLM-2-HK-4	2-1/2	1-1/8	1	1/2	1-5/8	TAPPED	M8
CLM-3-HK-4						TAPPED	M10
CLM-4-HK-4						TAPPED	M12
CL-105-HK-10						BLANK	—
CL-90-HK-9	2-1/2	1-1/8	1	1/2	1-5/8	TAPPED	1/2-13 x 1-1/4 DEEP
CL-100-HK-10						TAPPED	5/8-11 x 1-1/4 DEEP
CLM-90-HK-9						TAPPED	M12 x 1-1/4 DEEP
CL-9-HK-9						TAPPED	1/2-13
CL-10-HK-10	2-3/4	1-3/8	3/4	1/2	1-1/2	TAPPED	5/8-11
CLM-9-HK-9						TAPPED	M12
CLM-10-HK-10						TAPPED	M16
CL-65-HK-6						BLANK	—
CL-50-HK-6	2-3/4	1-3/8	3/4	1/2	1-1/2	TAPPED	5/8-11 x 1-1/8 DEEP
CL-60-HK-6						TAPPED	3/4-10 x 1-1/8 DEEP
CLM-50-HK-6						TAPPED	M16 x 1-1/8 DEEP
CLM-60-HK-6						TAPPED	M20 x 1-1/8 DEEP
CL-5-HK-6	2-3/4	1-3/8	3/4	1/2	1-1/2	TAPPED	5/8-11
CL-6-HK-6						TAPPED	3/4-10
CLM-5-HK-6						TAPPED	M16
CLM-6-HK-6						TAPPED	M20

HAND KNOBS

319 ALUMINUM ALLOY

Aluminum

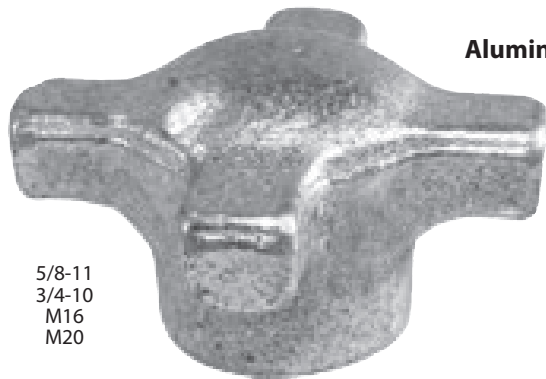

5/8-11
3/4-10
M16
M20



1/2-13
5/8-11
M12
M16

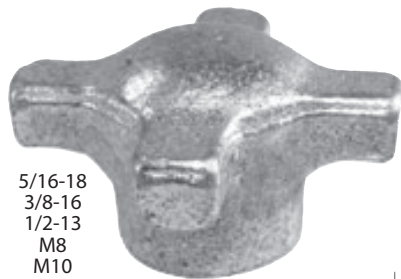

5/16-18
3/8-16
1/2-13
M8
M10
M12



1/4-20
5/16-18
M6
M8

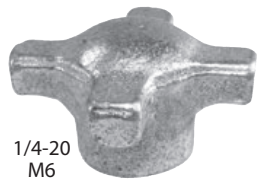

1/4-20
M6

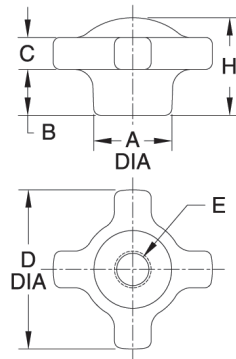

Classic easy-to-grip clamping knob, available in aluminum (shown here) or cast iron. Choose from five knob sizes, each available blank, tapped, tapped through, or reamed.

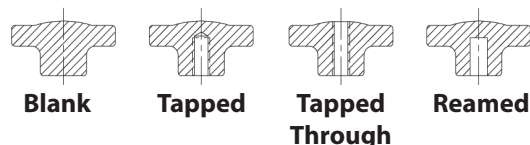

Blank

Tapped

Tapped Through

Reamed

ALUMINUM (INCH & METRIC)

PART NO. ALUMINUM	D DIA	A DIA	B	C	H	HOLE TYPE	E
CL-85-HK-8A						BLANK	—
CL-80-HK-8A						TAPPED	1/4-20 x 1/2 DEEP
CLM-80-HK-8A						TAPPED	M6 x 1/2 DEEP
CL-8-HK-8A	1-1/8	9/16	5/16	5/16	7/8	TAPPED THROUGH	1/4-20
CLM-8-HK-8A						TAPPED THROUGH	M6
CL-28-HK-8A						REAMED	1/4 x 1/2 DEEP
CLM-28-HK-8A						REAMED	6mm x 1/2 DEEP
CL-25-HK-2A						BLANK	—
CL-10-HK-2A						TAPPED	1/4-20 x 7/8 DEEP
CL-20-HK-2A						TAPPED	5/16-18 x 7/8 DEEP
CLM-10-HK-2A						TAPPED	M6 x 7/8 DEEP
CLM-20-HK-2A						TAPPED	M8 x 7/8 DEEP
CL-1-HK-2A	1-3/4	3/4	1/2	3/8	1-1/8	TAPPED THROUGH	1/4-20
CL-2-HK-2A						TAPPED THROUGH	5/16-18
CLM-1-HK-2A						TAPPED THROUGH	M6
CLM-2-HK-2A						TAPPED THROUGH	M8
CL-21-HK-2A						REAMED	1/4 x 7/8 DEEP
CL-22-HK-2A						REAMED	5/16 x 7/8 DEEP
CLM-21-HK-2A						REAMED	6mm x 7/8 DEEP
CLM-22-HK-2A						REAMED	8mm x 7/8 DEEP
CL-45-HK-4A						BLANK	—
CL-20-HK-4A						TAPPED	5/16-18 x 1 DEEP
CL-30-HK-4A						TAPPED	3/8-16 x 1 DEEP
CL-40-HK-4A						TAPPED	1/2-13 x 1 DEEP
CLM-20-HK-4A						TAPPED	M8 x 1 DEEP
CLM-30-HK-4A						TAPPED	M10 x 1 DEEP
CLM-40-HK-4A						TAPPED	M12 x 1 DEEP
CL-2-HK-4A	2-1/8	1	5/8	7/16	1-3/8	TAPPED THROUGH	5/16-18
CL-3-HK-4A						TAPPED THROUGH	3/8-16
CL-4-HK-4A						TAPPED THROUGH	1/2-13
CLM-2-HK-4A						TAPPED THROUGH	M8
CLM-3-HK-4A						TAPPED THROUGH	M10
CLM-4-HK-4A						TAPPED THROUGH	M12
CL-23-HK-4A						REAMED	3/8 x 1 DEEP
CL-24-HK-4A						REAMED	1/2 x 1 DEEP
CLM-23-HK-4A						REAMED	10mm x 1 DEEP
CLM-24-HK-4A						REAMED	12mm x 1 DEEP
CL-105-HK-10A						BLANK	—
CL-90-HK-9A						TAPPED	1/2-13 x 1-1/4 DEEP
CL-100-HK-10A						TAPPED	5/8-11 x 1-1/4 DEEP
CLM-90-HK-9A						TAPPED	M12 x 1-1/4 DEEP
CLM-100-HK-10A						TAPPED	M16 x 1-1/4 DEEP
CL-9-HK-9A	2-1/2	1-1/8	1	1/2	1-5/8	TAPPED THROUGH	1/2-13
CL-10-HK-10A						TAPPED THROUGH	5/8-11
CLM-9-HK-9A						TAPPED THROUGH	M12
CLM-10-HK-10A						TAPPED THROUGH	M16
CL-29-HK-9A						REAMED	1/2 x 1-1/4 DEEP
CL-31-HK-10A						REAMED	5/8 x 1-1/4 DEEP
CLM-29-HK-9A						REAMED	12mm x 1-1/4 DEEP
CLM-31-HK-10A						REAMED	16mm x 1-1/4 DEEP
CL-65-HK-6A						BLANK	—
CL-50-HK-6A						TAPPED	5/8-11 x 1-1/8 DEEP
CL-60-HK-6A						TAPPED	3/4-10 x 1-1/8 DEEP
CLM-50-HK-6A						TAPPED	M16 x 1-1/8 DEEP
CLM-60-HK-6A						TAPPED	M20 x 1-1/8 DEEP
CL-5-HK-6A	2-3/4	1-3/8	3/4	1/2	1-1/2	TAPPED THROUGH	5/8-11
CL-6-HK-6A						TAPPED THROUGH	3/4-10
CLM-5-HK-6A						TAPPED THROUGH	M16
CLM-6-HK-6A						TAPPED THROUGH	M20
CL-25-HK-6A						REAMED	5/8 x 1-1/8 DEEP
CL-26-HK-6A						REAMED	3/4 x 1-1/8 DEEP
CLM-25-HK-6A						REAMED	16mm x 1-1/8 DEEP
CLM-26-HK-6A						REAMED	20mm x 1-1/8 DEEP

3

HAND KNOBS

EXTRUDED HAND KNOB, EXTRUDED ALUMINUM, GREEN ANODIZE

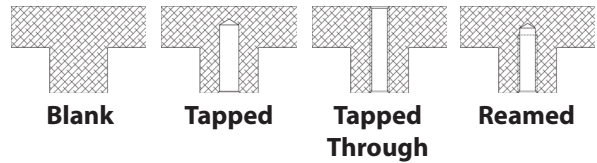
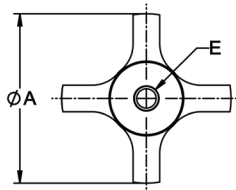
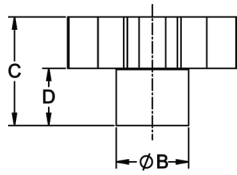

Extruded hand knob use, easy-to-grip aluminum clamping knob. Four-prong design provides a firm grip for applications requiring quick tightening and high torque. Extruded hand knobs available blank, tapped, tapped through, or reamed. Available with tapped-hole sizes from 1/4-20 to 3/4-10 (M6 to M20 in metric) and reamed hole sizes from 1/4 to 3/4 (6mm to 20mm in metric).

GREEN ANODIZE (INCH)

PART NO.	A DIA	B DIA	C	D	E DIA	E DEPTH
CL-0-HKE-00	1	1/2	7/8	1/2	-	-
CL-0-HKE-10	1-1/2	5/8	7/8	3/8	-	-
CL-0-HKE-20	1-3/4	3/4	1-1/8	19/32	-	-
CL-0-HKE-30	2	13/16	1-3/8	3/4	-	-
CL-0-HKE-40	2-1/2	1	1-1/2	25/32	-	-
CL-0-HKE-50	3	1-1/4	1-1/4	5/8	-	-
CL-4R-HKE-00	1	1/2	7/8	1/2	1/4	1/2
CL-3R-HKE-20	1-3/4	3/4	1-1/8	19/32	3/16	3/4
CL-4R-HKE-20	1-3/4	3/4	1-1/8	19/32	1/4	3/4
CL-5R-HKE-20	1-3/4	3/4	1-1/8	19/32	5/16	3/4
CL-5R-HKE-30	2	13/16	1-3/8	3/4	5/16	1
CL-6R-HKE-30	2	13/16	1-3/8	3/4	3/8	1
CL-8R-HKE-30	2	13/16	1-3/8	3/4	1/2	1
CL-8R-HKE-40	2-1/2	1	1-1/2	25/32	1/2	1-1/4
CL-10R-HKE-40	2-1/2	1	1-1/2	25/32	5/8	1-1/4
CL-12R-HKE-40	2-1/2	1	1-1/2	25/32	3/4	1-1/4
CL-4T-HKE-00	1	1/2	7/8	1/2	1/4-20	1/2
CL-4T-HKE-20	1-3/4	3/4	1-1/8	19/32	1/4-20	3/4
CL-5T-HKE-20	1-3/4	3/4	1-1/8	19/32	5/16-18	3/4
CL-5T-HKE-30	2	13/16	1-3/8	3/4	5/16-18	1
CL-6T-HKE-30	2	13/16	1-3/8	3/4	3/8-16	1
CL-8T-HKE-30	2	13/16	1-3/8	3/4	1/2-13	1
CL-8T-HKE-40	2-1/2	1	1-1/2	25/32	1/2-13	1
CL-10T-HKE-40	2-1/2	1	1-1/2	25/32	5/8-11	1
CL-12T-HKE-40	2-1/2	1	1-1/2	25/32	3/4-10	1
CL-4T-HKE-00	1	1/2	7/8	1/2	1/4-20	1/2
CL-4T-HKE-20	1-3/4	3/4	1-1/8	19/32	1/4-20	3/4
CL-5T-HKE-20	1-3/4	3/4	1-1/8	19/32	5/16-18	3/4
CL-5T-HKE-30	2	13/16	1-3/8	3/4	5/16-18	1
CL-6T-HKE-30	2	13/16	1-3/8	3/4	3/8-16	1
CL-8T-HKE-30	2	13/16	1-3/8	3/4	1/2-13	1
CL-8T-HKE-40	2-1/2	1	1-1/2	25/32	1/2-13	1
CL-10T-HKE-40	2-1/2	1	1-1/2	25/32	5/8-11	1
CL-12T-HKE-40	2-1/2	1	1-1/2	25/32	3/4-10	1

GREEN ANODIZE (METRIC)

PART NO.	A DIA (mm)	B DIA (mm)	C (mm)	D (mm)	E DIA (mm)	E DEPTH (mm)
CLM-6R-HKE-00	25.5	13	22	12.5	6	12.5
CLM-6R-HKE-20	44.5	19	28.5	15	6	19
CLM-8R-HKE-20	44.5	19	28.5	15	8	19
CLM-10R-HKE-30	51	20.5	35	19	10	25.5
CLM-12R-HKE-30	51	20.5	35	19	12	25.5
CLM-12R-HKE-40	63.5	25.5	38	20	12	32
CLM-16R-HKE-40	63.5	25.5	38	20	16	32
CLM-20R-HKE-40	63.5	25.5	38	20	20	32

PART NO.	A DIA (mm)	B DIA (mm)	C (mm)	D (mm)	E THREAD	THREAD PITCH (mm)	E DEPTH (mm)
CLM-6T-HKE-00	25.5	13	22	12.5	M6	1	12.5
CLM-6T-HKE-20	44.5	19	28.5	15	M6	1	19
CLM-8T-HKE-20	44.5	19	28.5	15	M8	1.25	19
CLM-8T-HKE-30	51	20.5	35	19	M8	1.25	25.5
CLM-10T-HKE-30	51	20.5	35	19	M10	1.5	25.5
CLM-12T-HKE-30	51	20.5	35	19	M12	1.75	25.5
CLM-12T-HKE-40	63.5	25.5	38	20	M12	1.75	25.5
CLM-16T-HKE-40	63.5	25.5	38	20	M16	2	25.5
CLM-20T-HKE-40	63.5	25.5	38	20	M20	2.5	25.5

PART NO.	A DIA (mm)	B DIA (mm)	C (mm)	D (mm)	E THREAD	THREAD PITCH (mm)
CLM-6TT-HKE-00	25.5	13	22	12.5	M6	1
CLM-6TT-HKE-20	44.5	19	28.5	15	M6	1
CLM-8TT-HKE-20	44.5	19	28.5	15	M8	1.25
CLM-8TT-HKE-30	51	20.5	35	19	M8	1.25
CLM-10TT-HKE-30	51	20.5	35	19	M10	1.5
CLM-12TT-HKE-30	51	20.5	35	19	M12	1.75
CLM-12TT-HKE-40	63.5	25.5	38	20	M12	1.75
CLM-16TT-HKE-40	63.5	25.5	38	20	M16	2
CLM-20TT-HKE-40	63.5	25.5	38	20	M20	2.5

EXTRUDED HAND KNOB

HAND KNOB: EXTRUDED ALUMINUM, GREEN ANODIZE,
SCREW: 1215 STEEL, ZINC PLATED CLEAR CHROMATE

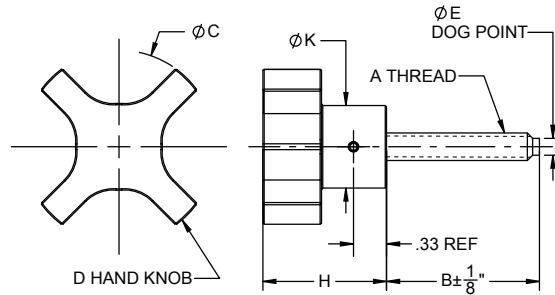
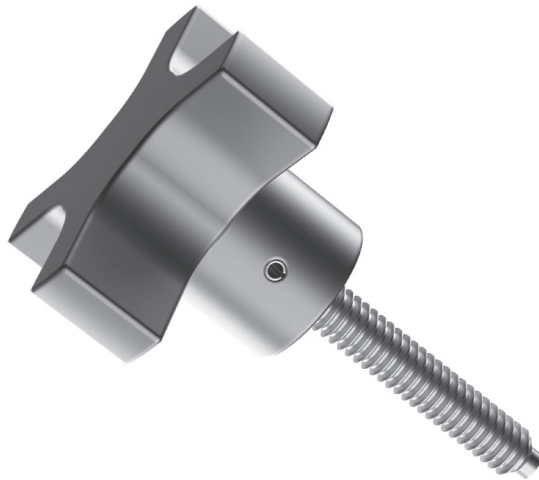

Extruded, easy-to-grip hand knob with an integral steel clamping screw. Four-prong design provides a firm grip for applications requiring quick tightening and high torque. Made in U.S.A.

GREEN ANODIZE (INCH)

PART NO.	A THREAD	B	C DIA	D	E DIA	H	K DIA
CL-1-HKE2T	1/4-20	1	1-3/4	CL-4T-HKE-20	.15	1-1/8	3/4
CL-2-HKE2T		1-1/2					
CL-2A-HKE2T		2					
CL-2B-HKE2T		3					
CL-3A-HKE2T	5/16-18	1		CL-5T-HKE-20	.20		
CL-3-HKE2T		1-3/4					
CL-4-HKE2T		2-1/2					
CL-4A-HKE4T		3					
CL-5A-HKE4T	3/8-16	1	2	CL-6T-HKE-30	.25	1-3/8	13/16
CL-5B-HKE4T		1-1/2					
CL-5-HKE4T		2					
CL-6-HKE4T		2-1/2					
CL-6A-HKE4T	1/2-13	3		CL-8T-HKE-30	.34		
CL-7A-HKE4T		1					
CL-7B-HKE4T		1-1/2					
CL-7C-HKE4T		2					
CL-7-HKE4T	5/8-11	2-1/2	2-1/2	CL-10T-HKE-40	.46	1-1/2	1
CL-8-HKE4T		3					
CL-9-HKE6T		1-3/4					
CL-10-HKE6T		3					
CL-12-HKE6T	3/4-10	3		CL-12T-HKE-40	.56		

GREEN ANODIZE (METRIC)

PART NO.	A THREAD	THREAD PITCH (mm)	B (mm)	C DIA (mm)	D	E DIA (mm)	H (mm)	K DIA (mm)
CLM-1-HKE2T	M6x1.0	1	25	44	CLM-6T-HKE-20	4.4	28	19
CLM-2-HKE2T			40					
CLM-3A-HKE2T	M8x1.25	1.25	25		CLM-8T-HKE-20	5.9		
CLM-3-HKE2T			45					
CLM-4-HKE2T	M10x1.5	1.5	65	51	CLM-10T-HKE-30	6.9		
CLM-5A-HKE4T			25					
CLM-5B-HKE4T			40					
CLM-5-HKE4T			50					
CLM-6-HKE4T	M12x1.75	1.75	65		CLM-12T-HKE-30	8.9		
CLM-7A-HKE4T			25					
CLM-7B-HKE4T			40					
CLM-7C-HKE4T			50					
CLM-7-HKE4T	M16x2.0	2	65	64	CLM-16T-HKE-40	11.9	38	25
CLM-8-HKE4T			75					
CLM-9-HKE6T			45					
CLM-10-HKE6T			75					
CLM-12-HKE6T	M20x2.5	2.5	75		CLM-20T-HKE-40			

HAND KNOB ASSEMBLIES

KNOB: 319 ALUMINUM ALLOY
SCREW: 1215 STEEL, ZINC PLATED CLEAR CHROMATE

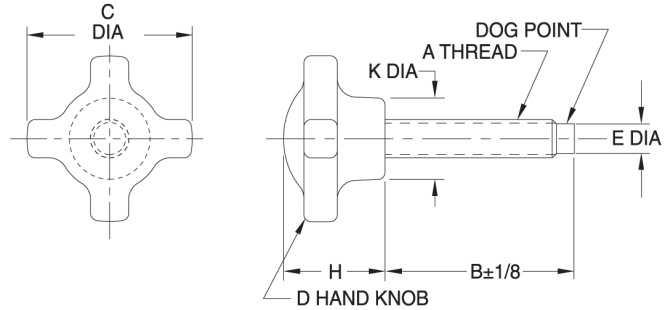

INCH

PART NO.	A	B	C DIA	D	E DIA	H	K DIA
CL-1-HK2T	1/4-20	1	1-3/4	CL-25-HK-2A	.15	1-1/8	3/4
CL-2-HK2T		1-1/2					
CL-2A-HK2T		2					
CL-2B-HK2T		3					
CL-3A-HK2T	5/16-18	1	1-3/4	CL-25-HK-2A	.20	1-1/8	3/4
CL-3-HK2T		1-3/4					
CL-4-HK2T		2-1/2					
CL-4A-HK2T		3					
CL-5A-HK4T	3/8-16	1	2-1/8	CL-45-HK-4A	.25	1-3/8	1
CL-5B-HK4T		1-1/2					
CL-5-HK4T		2					
CL-6-HK4T		2-1/2					
CL-6A-HK4T	1/2-13	3	2-1/8	CL-45-HK-4A	.34	1-3/8	1
CL-7A-HK4T		1					
CL-7B-HK4T		1-1/2					
CL-7C-HK4T		2					
CL-7-HK4T	1/2-13	2-1/2	2-1/8	CL-45-HK-4A	.34	1-3/8	1
CL-8-HK4T		3					
CL-9-HK6T	5/8-11	1-3/4	2-3/4	CL-65-HK-6A	.46	1-1/2	1-3/8
CL-10-HK6T		3					
CL-12-HK6T	3/4-10	3	2-3/4	CL-65-HK-6A	.56	1-1/2	1-3/8

Classic, easy-to-grip aluminum knob with an integral steel clamping screw. Four-prong design provides a firm grip for applications requiring quick tightening and high torque. Choice of three knob sizes. Available in thread sizes from 1/4-20 to 3/4-10 (M6 to M20 in metric), most in a choice of several thread lengths.

METRIC

PART NO.	A THREAD	THREAD PITCH (mm)	B (mm)	C DIA (mm)	D	E DIA (mm)	H (mm)	K DIA (mm)
CLM-1-HK2T	M6	1	25	44	CL-25-HK-2A	4.4	29	19
CLM-2-HK2T			40					
CLM-3A-HK2T	M8	1.25	25	44	CL-25-HK-2A	5.9	29	19
CLM-3-HK2T			45					
CLM-4-HK2T	M10	1.5	65	54	CL-45-HK-4A	6.9	35	25
CLM-5A-HK4T			25					
CLM-5B-HK4T	M10	1.5	40	54	CL-45-HK-4A	6.9	35	25
CLM-5-HK4T			50					
CLM-6-HK4T	M12	1.75	65	54	CL-45-HK-4A	8.9	35	25
CLM-7A-HK4T			25					
CLM-7B-HK4T	M12	1.75	40	54	CL-45-HK-4A	8.9	35	25
CLM-7C-HK4T			50					
CLM-7-HK4T	M12	1.75	65	54	CL-45-HK-4A	8.9	35	25
CLM-8-HK4T			75					
CLM-9-HK6T	M16	2	45	70	CL-65-HK-6A	11.9	38	35
CLM-10-HK6T			75					
CLM-12-HK6T	M20	2.5	75	70	CL-65-HK-6A	14.9	38	35

EXTRUDED HAND KNOB ASSEMBLIES

HAND KNOB: EXTRUDED ALUMINUM, GREEN ANODIZE,
SCREW: 1215 STEEL, ZINC PLATED CLEAR CHROMATE

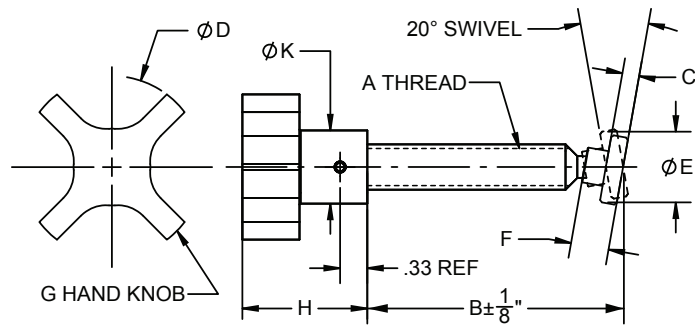

Extruded Hand knob assembly with a removable swivel foot. Clamping screw is securely pinned in the knob. Four-prong design provides a firm grip for applications requiring quick tightening and high torque. Made in U.S.A.

INCH

PART NO.	A THREAD	B	C	D DIA	E DIA	F	G	H	K DIA
CL-1-KESA	1/4-20	1-1/4	1/8	1	3/8	5/16	CL-4T-HKE-00	7/8	.51
CL-2-KESA	1/4-20	2	1/8	1	3/8	5/16	CL-4T-HKE-00	7/8	.51
CL-2A-KESA	1/4-20	2	1/8	1-1/2	3/8	5/16	CL-4T-HKE-20	1-1/8	.75
CL-3-KESA	5/16-18	1-1/2	5/32	1-1/2	1/2	11/32	CL-5T-HKE-20	1-1/8	.75
CL-4-KESA	5/16-18	2-1/4	5/32	1-1/2	1/2	11/32	CL-5T-HKE-20	1-1/8	.75
CL-4A-KESA	5/16-18	2-3/4	5/32	1-1/2	1/2	11/32	CL-5T-HKE-20	1-1/8	.75
CL-5-KESA	3/8-16	2-1/16	3/16	2	9/16	7/16	CL-6T-HKE-30	1-3/8	.81
CL-6-KESA	3/8-16	2-13/16	3/16	2	9/16	7/16	CL-6T-HKE-30	1-3/8	.81
CL-7-KESA	3/8-16	3-9/16	3/16	2	9/16	7/16	CL-6T-HKE-30	1-3/8	.81
CL-8-KESA	1/2-13	2-13/16	3/16	2	3/4	27/64	CL-8T-HKE-30	1-3/8	.81
CL-9-KESA	1/2-13	3-9/16	3/16	2	3/4	27/64	CL-8T-HKE-30	1-3/8	.81
CL-10-KESA	1/2-13	4-5/16	3/16	2	3/4	27/64	CL-8T-HKE-30	1-3/8	.81
CL-11-KESA	5/8-11	3-5/16	7/32	2-1/2	15/16	33/64	CL-10T-HKE-40	1-1/2	1.00
CL-13-KESA	5/8-11	4-13/16	7/32	2-1/2	15/16	33/64	CL-10T-HKE-40	1-1/2	1.00
CL-14-KESA	3/4-10	3-5/16	7/32	2-1/2	15/16	33/64	CL-12T-HKE-40	1-1/2	1.00
CL-16-KESA	3/4-10	4-13/16	7/32	2-1/2	15/16	33/64	CL-12T-HKE-40	1-1/2	1.00

INCH

PART NO.	A THREAD	THREAD PITCH (mm)	B (mm)	C (mm)	D DIA (mm)	E DIA (mm)	F (mm)	G	H (mm)	K DIA (mm)
CLM-1-KESA	M6	1	25	3.2	25	9.5	7.5	CLM-6T-HKE-00	22	13
CLM-2-KESA	M6	1	50	3.2	25	9.5	7.5	CLM-6T-HKE-00	22	13
CLM-3-KESA	M8	1.25	40	4	44	12.5	9	CLM-8T-HKE-20	28	19
CLM-4-KESA	M8	1.25	60	4	44	12.5	9	CLM-8T-HKE-20	28	19
CLM-5-KESA	M10	1.5	50	4.8	51	14.5	11	CLM-10T-HKE-30	35	21
CLM-6-KESA	M10	1.5	90	4.8	51	14.5	11	CLM-10T-HKE-30	35	21
CLM-7-KESA	M12	1.75	70	4.8	64	19	10.5	CLM-12T-HKE-40	38	25
CLM-8-KESA	M12	1.75	110	4.8	64	19	10.5	CLM-12T-HKE-40	38	25
CLM-9-KESA	M16	2	80	5.5	64	23.5	13	CLM-16T-HKE-40	38	25
CLM-10-KESA	M16	2	120	5.5	64	23.5	13	CLM-16T-HKE-40	38	25

SWIVEL-WASHER HAND KNOB ASSEMBLIES

KNOB: 319 ALUMINUM ALLOY
 SCREW: 1215 STEEL, BLACK OXIDE FINISH.
 WASHER: MILD STEEL

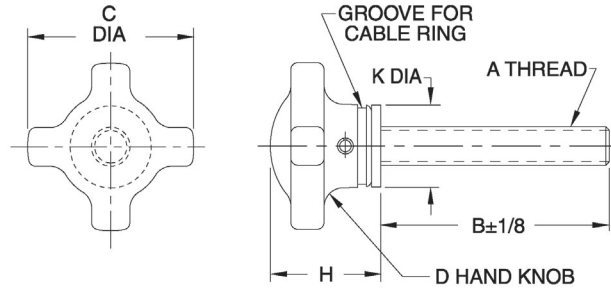

ASSEMBLY WITH STEEL WASHER (INCH)

PART NO.	A	B	C DIA	D	H	K DIA	CABLE RING SIZE
CL-1-SHK2T	1/4-20	1	1-3/4	CL-25-HK-2A	1.33	3/4	CL-11-KR
CL-2-SHK2T		1-1/2					
CL-2A-SHK2T		2					
CL-2B-SHK2T		3					
CL-3A-SHK2T	5/16-18	1	1-3/4	CL-25-HK-2A	1.34	3/4	CL-11-KR
CL-3-SHK2T		1-3/4					
CL-4-SHK2T		2-1/2					
CL-4A-SHK2T		3					
CL-5A-SHK4T	3/8-16	1	2-1/8	CL-45-HK-4A	1.47	1	CL-14-KR
CL-5B-SHK4T		1-1/2					
CL-5-SHK4T		2					
CL-6-SHK4T		2-1/2					
CL-6A-SHK4T	1/2-13	3	2-1/8	CL-45-HK-4A	1.53	1	CL-14-KR
CL-7A-SHK4T		1					
CL-7B-SHK4T		1-1/2					
CL-7C-SHK4T		2					
CL-7-SHK4T	1/2-13	2-1/2	2-1/8	CL-45-HK-4A	1.53	1	CL-14-KR
CL-8-SHK4T		3					
CL-9-SHK6T		1-3/4					
CL-10-SHK6T	5/8-11	3	2-3/4	CL-65-HK-6A	1.66	1-3/8	CL-19-KR
CL-12-SHK6T	3/4-10	3	2-3/4	CL-65-HK-6A	1.77	1-3/8	CL-19-KR

ASSEMBLY WITH NYLON WASHER (INCH)

PART NO.	A	B	C DIA	D	H	K DIA	CABLE RING SIZE
CL-1-SHK2TN	1/4-20	1	1-3/4	CL-25-HK-2A	1.33	3/4	CL-11-KR
CL-2-SHK2TN		1-1/2			1.34		
CL-3-SHK2TN	5/16-18	1-3/4	1-3/4	CL-25-HK-2A	1.34	3/4	CL-11-KR
CL-5A-SHK4TN	3/8-16	1	2-1/8	CL-45-HK-4A	1.47	1	CL-14-KR
CL-7A-SHK4TN	1/2-13	1			1.53		
CL-7B-SHK4TN	1/2-13	1-1/2	2-1/8	CL-45-HK-4A	1.53	1	CL-14-KR

Hand-knob assembly with a captive, freely rotating washer to prevent marring in clamping applications. Four-prong design provides a firm grip for applications requiring quick tightening and high torque. Plain-end screw with no dogpoint. Choice of three knob sizes. Available in thread sizes from 1/4-20 to 3/4-10, most in a choice of several thread lengths.

KNOB SHOE ASSEMBLIES

HAND KNOB: EXTRUDED ALUMINUM, GREEN ANODIZE
 SCREW: 1215 STEEL, BLACK OXIDE FINISH OR ZINC PLATED CLEAR CHROMATE
 FOOT: 1215 STEEL, BLACK OXIDE FINISH OR ZINC PLATED YELLOW CHROMATE (OR DELRIN®)

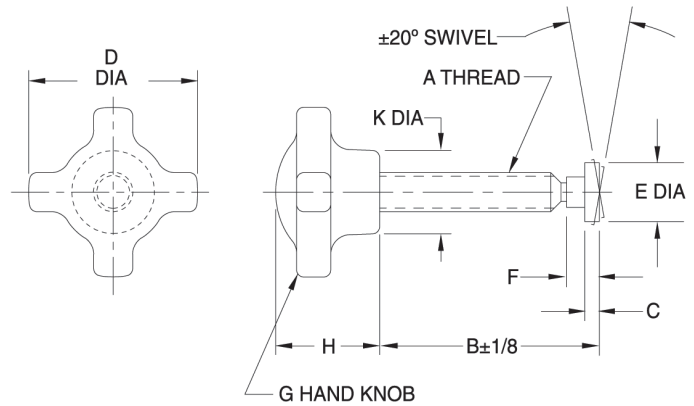

This hand-knob assembly features an integral steel clamping screw with a removable swivel foot. Four-prong design provides a firm grip for applications requiring quick tightening and high torque. Choice of four knob sizes. Available in thread sizes from 1/4-20 to 3/4-10 (M6 to M20 in metric), most in a choice of several thread lengths.

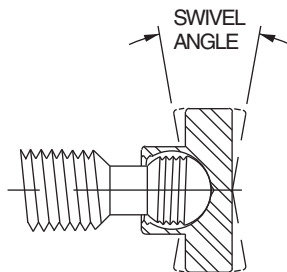

Knob Shoe Assemblies use our patented left-hand-thread swivel-foot system. The ball end of the body screws into the foot for easy installation and removal. Once the ball threads pass beyond the foot threads, the foot can rotate and pivot freely (20° total angle). Foot threads are left-hand to positively prevent accidental backout during use. Delrin® feet are optional. To order with a Delrin® foot, add "N" to the part number, e.g. CL-1-KSAN. Note: Delrin® feet are not threaded – they snap on and off. INFO+: For other foot types, see Feet for Swivel Screws on page 122 (order separately).

INCH

PART NO.	A	B	C	D DIA	E DIA	F	G	H	K DIA
CL-1-KSA	1/4-20	1-1/4	1/8	1-1/8	3/8	5/16	CL-85-HK-8A	7/8	9/16
CL-2-KSA		2							
CL-2A-KSA	1/4-20	2	1/8	1-3/4	3/8	5/16	CL-25-HK-2A	1-1/8	3/4
CL-3-KSA		1-1/2	5/32	1-3/4	1/2	11/32	CL-25-HK-2A	1-1/8	3/4
CL-4-KSA	5/16-18	2-1/4							
CL-4A-KSA		2							
CL-5-KSA		2-1/16							
CL-6-KSA	3/8-16	2-13/16	3/16	2-1/8	9/16	7/16	CL-45-HK-4A	1-3/8	1
CL-7-KSA		3-9/16							
CL-8-KSA		2-13/16							
CL-9-KSA	1/2-13	3-9/16							
CL-10-KSA		4-5/16	7/32	2-3/4	15/16	33/64	CL-65-HK-6A	1-1/2	1-3/8
CL-11-KSA	5/8-11	3-5/16							
CL-13-KSA		4-13/16							
CL-14-KSA	3/4-10	3-5/16							
CL-16-KSA		4-13/16							

METRIC

PART NO.	A THREAD	THREAD PITCH (mm)	B (mm)	C (mm)	D DIA (mm)	E DIA (mm)	F (mm)	G	H (mm)	K DIA (mm)
CLM-1-KSA	M6	1	25	3.2	29	9.5	7.5	CL-85-HK-8A	22	14
CLM-2-KSA			50					CL-85-HK-8A		
CLM-3-KSA	M8	1.25	40	4	44	12.5	9	CL-25-HK-2A	29	19
CLM-4-KSA			60					CL-25-HK-2A		
CLM-5-KSA	M10	1.5	50	4.8	54	14.5	11	CL-45-HK-4A	35	25
CLM-6-KSA			90					CL-45-HK-4A		
CLM-7-KSA	M12	1.75	70			19	10.5	CL-45-HK-4A		
CLM-8-KSA			110					CL-45-HK-4A		
CLM-9-KSA	M16	2	80	5.5	70	23.5	13	CL-65-HK-6A	38	35
CLM-10-KSA			120					CL-65-HK-6A		

HAND KNOBS – STAINLESS STEEL

300-SERIES STAINLESS STEEL

3

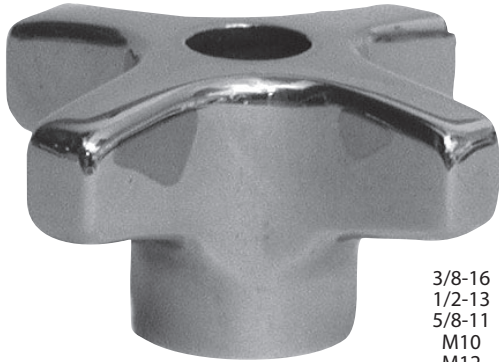

3/8-16
1/2-13
5/8-11
M10
M12
M16

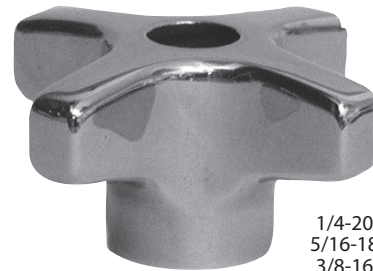

1/4-20
5/16-18
3/8-16
M6
M8
M10

High-quality, stainless steel knob with a beautiful polished finish. Four-prong design provides a firm grip for applications requiring quick tightening and high torque. Choose from two knob sizes, each available blank, tapped, tapped through, or reamed.

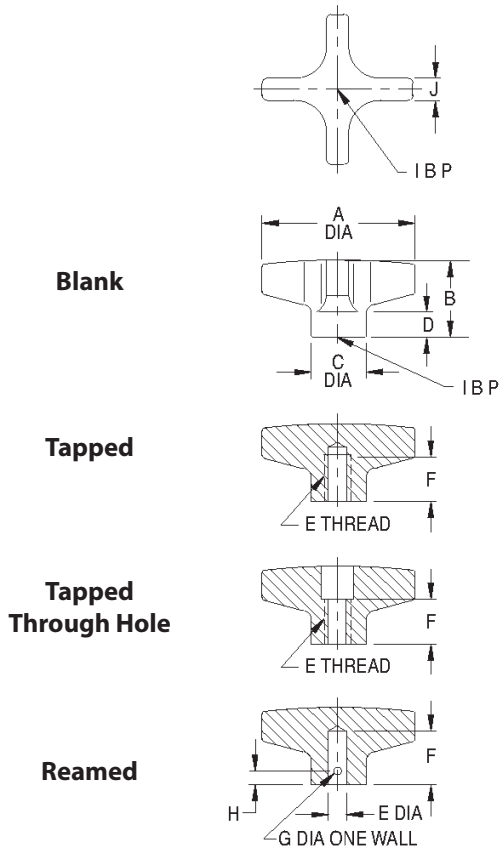

INCH & METRIC

PART NO.	A DIA	B	C DIA	D	HOLE TYPE	E	F	G	H	J
CL-200-HK-S	2	1.02	.78	.34	BLANK	—	—	—	—	.33
CL-240-HK-S					TAPPED	1/4-20	11/16	—	—	
CL-250-HK-S						5/16-18				
CL-260-HK-S						3/8-16				
CLM-260-HK-S						M6				
CLM-280-HK-S						M8				
CLM-2100-HK-S					M10					
CL-241-HK-S					TAPPED THROUGH	1/4-20	1/2	—	—	
CL-251-HK-S						5/16-18	5/8			
CL-261-HK-S						3/8-16	3/4			
CLM-261-HK-S						M6	1/2			
CLM-281-HK-S						M8	5/8			
CLM-2101-HK-S	M10	3/4								
CL-255-HK-S	REAMED	5/16	11/16	1/8	3/16					
CL-265-HK-S		3/8		5/32						
CL-600-HK-S	3	1.50	1.14	.50	BLANK	—	—	—	—	.47
CL-660-HK-S					TAPPED	3/8-16	1	—	—	
CL-680-HK-S						1/2-13				
CL-6100-HK-S						5/8-11				
CLM-6100-HK-S						M10				
CLM-6120-HK-S						M12				
CLM-6160-HK-S					M16					
CL-661-HK-S					TAPPED THROUGH	3/8-16	3/4	—	—	
CL-681-HK-S						1/2-13	1			
CL-6101-HK-S						5/8-11	1-1/4			
CLM-6101-HK-S						M10	1			
CLM-6121-HK-S						M12				
CLM-6161-HK-S						M16				
CL-665-HK-S					REAMED	3/8	1	5/32	1/4	
CL-685-HK-S						1/2		3/16		

FOUR-PRONG KNOBS

KNOB: BLACK PHENOLIC PLASTIC WITH BRASS INSERT
STUD: MILD STEEL, ZINC PLATED CLEAR CHROMATE

Phenolic — Tapped

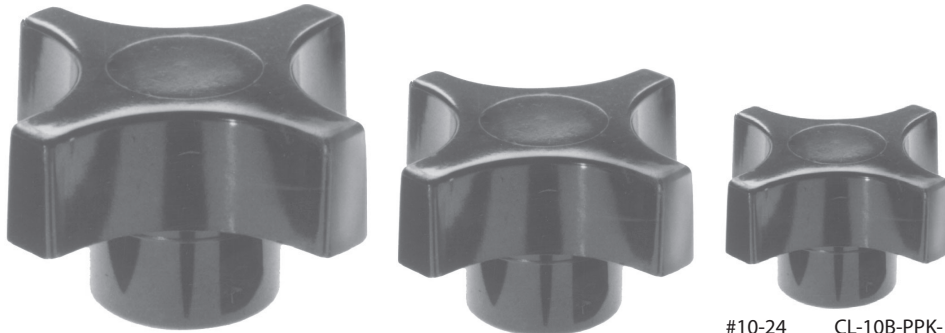

5/16-18 CL-20-PPK-4
3/8-16 CL-30-PPK-4
1/2-13 CL-40-PPK-4
M10 CLM-10-PPK-4

1/4-20 CL-10-PPK-2
5/16-18 CL-20-PPK-2
3/8-16 CL-30-PPK-2
M8 CLM-8-PPK-2

#10-24 CL-10B-PPK-1
#10-32 CL-10A-PPK-1
1/4-20 CL-10-PPK-1
5/16-18 CL-20-PPK-1
M6 CLM-6-PPK-1

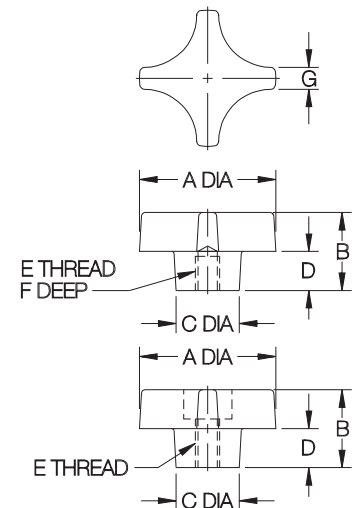

Phenolic — Tapped Through Hole

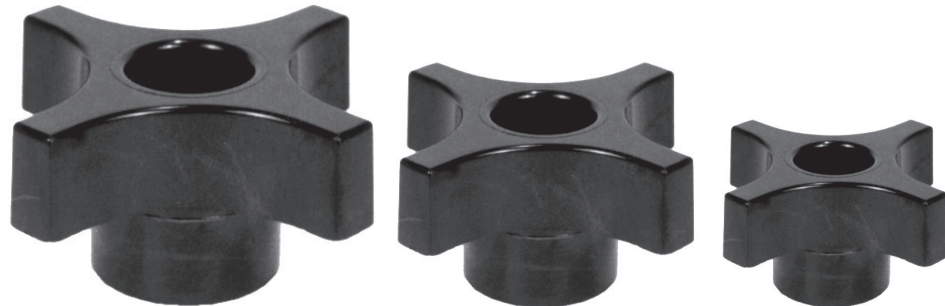

5/16-18 CL-2-PPK-4
3/8-16 CL-3-PPK-4
1/2-13 CL-4-PPK-4

1/4-20 CL-1-PPK-2
5/16-18 CL-2-PPK-2
3/8-16 CL-3-PPK-2

#10-24 CL-1B-PPK-1
#10-32 CL-1A-PPK-1
1/4-20 CL-1-PPK-1

Four-prong design provides a strong grip for clamping and other applications requiring quick tightening and high torque. Choice of three knob sizes. Molded-in brass insert provides superior thread strength. INFO+: Also available with a molded-in clamping stud (page 110). Non-standard thread sizes, reamed holes, or other lengths of molded-in studs are available in quantities of 500 and above.

PHENOLIC — TAPPED (INCH & METRIC)

PART NO.	A	B	C DIA	D	E	F	G
CL-10B-PPK-1	1-1/4	7/8	5/8	3/8	#10-24	7/16	1/4
CL-10A-PPK-1					#10-32		
CL-10-PPK-1					1/4-20		
CL-20-PPK-1					5/16-18		
CLM-6-PPK-1					M6		
CL-10-PPK-2	1-3/4	1	13/16	1/2	1/4-20	1/2	9/32
CL-20-PPK-2					5/16-18		
CL-30-PPK-2					3/8-16		
CLM-8-PPK-2					M8		
CL-20-PPK-4	2-1/4	1-1/8	1	9/16	5/16-18	7/16	5/16
CL-30-PPK-4					3/8-16	1/2	
CL-40-PPK-4					1/2-13	5/8	
CLM-10-PPK-4					M10		

PHENOLIC — TAPPED THROUGH HOLE (INCH)

CL-1B-PPK-1	1-1/4	7/8	5/8	3/8	#10-24	5/16	1/4
CL-1A-PPK-1					#10-32		
CL-1-PPK-1					1/4-20		
CL-1-PPK-2	1-3/4	1	13/16	1/2	1/4-20	5/8	9/32
CL-2-PPK-2					5/16-18		
CL-3-PPK-2					3/8-16		
CL-2-PPK-4	2-1/4	1-1/8	1	9/16	5/16-18	5/8	5/16
CL-3-PPK-4					3/8-16		
CL-4-PPK-4					1/2-13		

FOUR-PRONG KNOBS



3/8-16 x 1
3/8-16 x 1-1/2
3/8-16 x 2
3/8-16 x 2-1/2
1/2-13 x 1-1/2
1/2-13 x 2
1/2-13 x 2-1/2
M10 x 40mm

CL-5A-PPK4T
CL-5B-PPK4T
CL-5-PPK4T
CL-6-PPK4T
CL-7B-PPK4T
CL-7C-PPK4T
CL-7-PPK4T
CLM-1040-PPK4T

1/4-20 x 1
5/16-18 x 1
5/16-18 x 1-1/2
5/16-18 x 2
M8 x 30mm

CL-1-PPK2T
CL-3A-PPK2T
CL-4A-PPK2T
CL-4B-PPK2T
CLM-830-PPK-2T

#10-24 x 3/4
#10-32 x 3/4
1/4-20 x 1
M6 x 20mm

CL-1B-PPK1T
CL-1A-PPK1T
CL-1-PPK1T
CLM-620-PPK1T

PHENOLIC — STUD TYPE (INCH & METRIC)

PART NO.	A	B	C DIA	D	E	F	G
CL-1B-PPK1T	1-1/4	7/8	5/8	3/8	#10-24	3/4	1/4
CL-1A-PPK1T					#10-32	3/4	
CL-1-PPK1T					1/4-20	1	
CLM-620-PPK1T	1-3/4	1	13/16	1/2	M6	.79	9/32
CL-1-PPK2T					1/4-20	1	
CL-3A-PPK2T					5/16-18	1-1/2	
CL-4A-PPK2T	2-1/4	1-1/8	1	9/16	M8	1.18	5/16
CL-4B-PPK2T					2		
CLM-830-PPK2T					1		
CL-5A-PPK4T	2-1/4	1-1/8	1	9/16	3/8-16	1	5/16
CL-5B-PPK4T						1-1/2	
CL-5-PPK4T						2	
CL-6-PPK4T					2-1/2		
CL-7B-PPK4T					1-1/2		
CL-7C-PPK4T					2		
CL-7-PPK4T	2-1/2						
CLM-1040-PPK4T	M10	1.57					

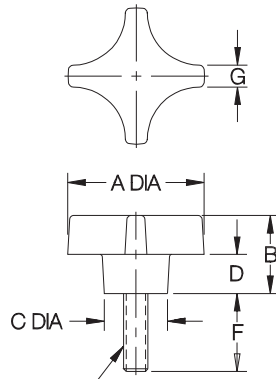

FOUR-PRONG KNOBS

BLACK THERMOPLASTIC WITH BRASS INSERT

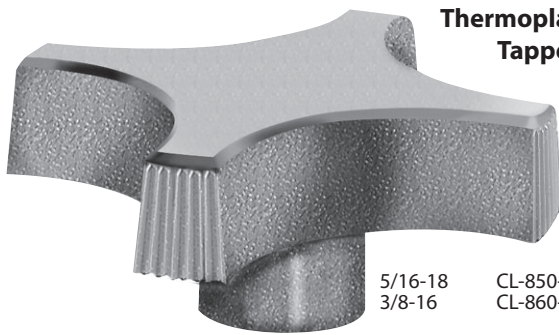

Thermoplastic —
Tapped

5/16-18 CL-850-PPK
3/8-16 CL-860-PPK

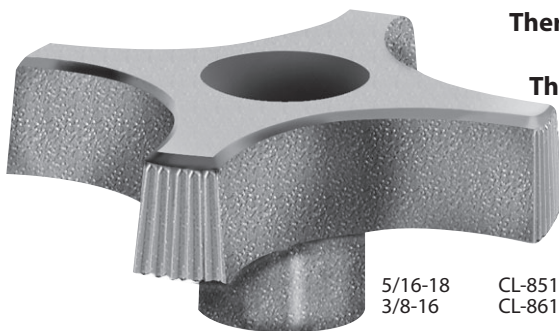

Thermoplastic —
Tapped
Through Hole

5/16-18 CL-851-PPK
3/8-16 CL-861-PPK

Four-prong design in thermoplastic, with a textured non-slip, non-glare finish. Molded-in brass insert provides superior thread strength. Non-standard thread sizes, reamed holes, molded-in studs, or special colors are available in quantities of 500 and above.

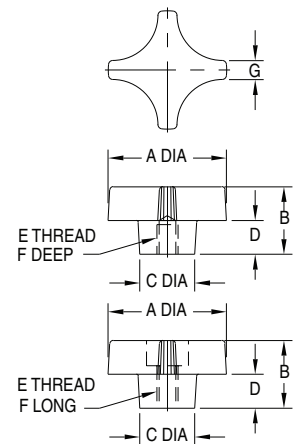

THERMOPLASTIC — TAPPED (INCH)

PART NO.	A	B	C DIA	D	E	F	G
CL-850-PPK	3	1-1/4	7/8	9/16	5/16-18	5/8	1/2
CL-860-PPK					3/8-16		

THERMOPLASTIC — TAPPED THROUGH HOLE (INCH)

PART NO.	A	B	C DIA	D	E	F	G
CL-851-PPK	3	1-1/4	7/8	9/16	5/16-18	5/8	1/2
CL-861-PPK					3/8-16		

QUICK-ACTING KNOBS

SINTERED IRON

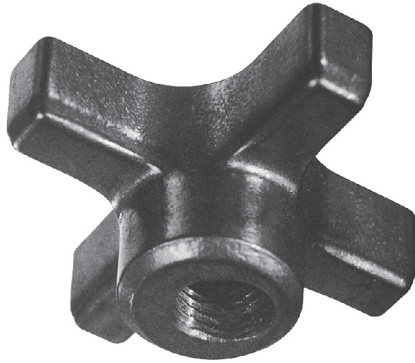

Quick-acting four-prong knob that slides in and out of clamping position, ideal when the knob must be completely removed for loading. Tilt knob to slide in, then straighten to engage threads and tighten. To remove, loosen knob, then tilt to slide out. Four-prong design provides a firm grip for applications requiring quick tightening and high torque. For full strength, use a stud that extends slightly beyond the knob, to engage all threads.

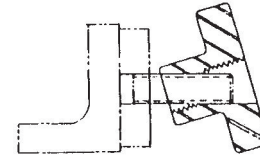
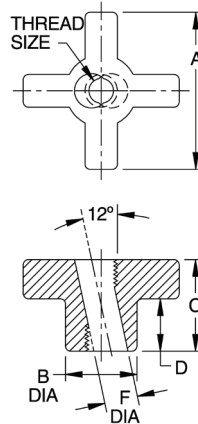

Tilt knob to slide in and out.

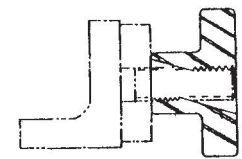

Straighten knob to engage threads for clamping.

INCH

PART NO.	THREAD SIZE	A	B DIA	C	D	F DIA
CL-1-QAK	1/4-20	1-1/8	9/16	5/8	5/16	17/64
CL-2-QAK	5/16-18	1-1/2	11/16	7/8	1/2	21/64
CL-3-QAK	3/8-16	2	13/16	1		25/64
CL-4-QAK	1/2-13	2-1/2	1	1-1/8	9/16	33/64
CL-5-QAK	5/8-11	3	1-1/4	1-1/4	5/8	41/64

METRIC

PART NO.	THREAD SIZE	THREAD PITCH (mm)	A (mm)	B DIA (mm)	C (mm)	D (mm)	F DIA (mm)
CLM-6-QAK	M6	1	29	14	16	8	6.5
CLM-8-QAK	M8	1.25	38	17	22	12.5	8.5
CLM-10-QAK	M10	1.5	51	21	25	12.5	10.5
CLM-12-QAK	M12	1.75	64	25	29	14	12.5
CLM-16-QAK	M16	2	76	32	32	16	16.5

3

BAR KNOBS

CAST IRON, ZINC PLATED CLEAR CHROMATE



Heavy-duty knob that can be turned easily by hand, then tightened by inserting a bar between the prongs. Choose from three knob sizes, each available blank or with a choice of tapped holes.

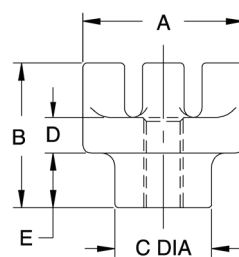
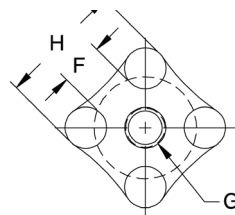
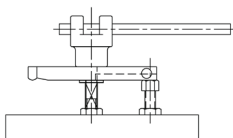

INCH & METRIC

PART NO.	A	B	C DIA	D	E	F	G	H
CL-1-BK	2	2-1/8	1-1/4	1/2	7/8	7/16	BLANK	1-5/8
CL-2-BK							3/8-16	
CL-4-BK							1/2-13	
CL-6-BK							5/8-11	
CLM-2-BK	2-1/2	2-3/8	1-1/2	9/16	15/16	11/16	M10	2
CLM-4-BK							M12	
CLM-6-BK							M16	
CL-8-BK							BLANK	
CL-9-BK	3-1/2	2-3/8	2-1/8	9/16	15/16	1-5/16	1/2-13	2-7/8
CL-11-BK							5/8-11	
CL-13-BK							3/4-10	
CLM-9-BK							M12	
CLM-11-BK	3-1/2	2-3/8	2-1/8	9/16	15/16	1-5/16	M16	2-7/8
CLM-13-BK							M20	
CL-15-BK							BLANK	
CL-16-BK							3/4-10	
CL-18-BK	3-1/2	2-3/8	2-1/8	9/16	15/16	1-5/16	7/8-9	2-7/8
CL-20-BK							1"-8	
CLM-16-BK							M20	
CLM-20-BK							M24	

THREE-PRONG KNOBS

BLACK THERMOPLASTIC WITH BRASS INSERT

3



5/16-18 CL-850-TPK
3/8-16 CL-860-TPK

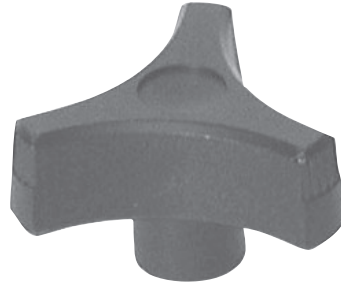

1/4-20 CL-640-TPK
5/16-18 CL-650-TPK
3/8-16 CL-660-TPK



1/4-20 CL-440-TPK
5/16-18 CL-450-TPK



5/16-18 CL-851-TPK
3/8-16 CL-861-TPK

**Thermoplastic —
Tapped Through Hole**

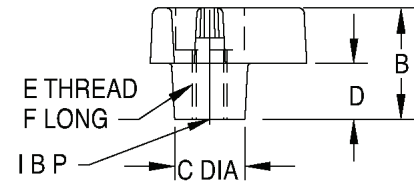
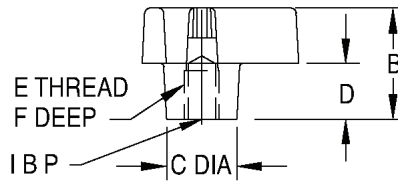
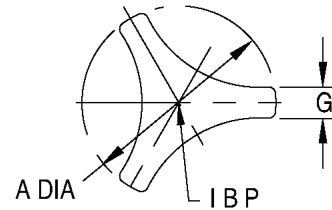

TERMOPLASTIC — TAPPED (INCH)

PART NO.	A DIA	B	C DIA	D	E	F	G
CL-440-TPK	1-1/2	7/8	1/2	3/8	1/4-20	7/16	9/32
CL-450-TPK					5/16-18		
CL-640-TPK	2	1-1/16	5/8	1/2	1/4-20	7/16	3/8
CL-650-TPK					5/16-18		
CL-660-TPK	2-1/2	1-1/8	3/4	1/2	3/8-16	7/16	1/2
CL-850-TPK					5/16-18		
CL-860-TPK					3/8-16		

TERMOPLASTIC — TAPPED THROUGH HOLE (INCH)

PART NO.	A DIA	B	C DIA	D	E	F	G
CL-851-TPK	2-1/2	1-1/8	3/4	1/2	5/16-18	5/8	1/2
CL-861-TPK					3/8-16		

Modern three-prong design provides quick tightening and high torque. Textured non-slip, non-glare finish. Choice of three knob sizes. Molded-in brass insert provides superior thread strength. Non-standard thread sizes, reamed holes, molded-in studs, or special colors are available in quantities of 500 and above.

T-HANDLE KNOBS

BLACK PHENOLIC PLASTIC OR THERMOPLASTIC
WITH BRASS INSERT

Phenolic — Tapped



- 1/4-20 CL-632-TK
- 5/16-18 CL-642-TK
- 3/8-16 CL-652-TK
- 3/8-24 CL-654-TK
- M8 CLM-642-TK
- M10 CLM-652-TK

Thermoplastic — Tapped

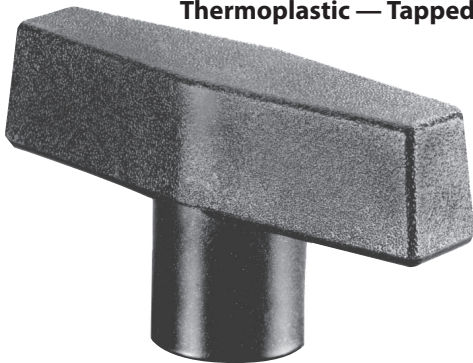

- 1/4-20 CL-6320-TK
- 5/16-18 CL-6420-TK
- 3/8-16 CL-6520-TK
- M8 CLM-6420-TK
- M10 CLM-6520-TK



- 1/4-20 CL-432-TK
- 5/16-18 CL-442-TK
- 3/8-16 CL-452-TK
- M6 CLM-432-TK
- M8 CLM-442-TK



- 1/4-20 CL-232-TK
- M6 CLM-232-TK

T-Handle Knobs provide maximum leverage for heavy-duty clamping. Ideal for fastening fold-down handles and stands. Available in phenolic plastic (one knob size) for a shiny polished finish, or in thermoplastic (three knob sizes) for a textured non-slip, non-glare finish. Molded-in brass insert provides superior thread strength. Non-standard thread sizes, reamed holes, molded-in studs, or special colors (thermoplastic only) are available in quantities of 500 and above.

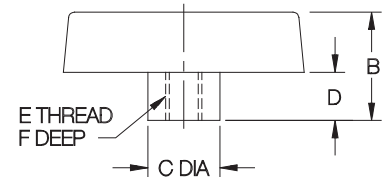
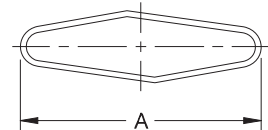
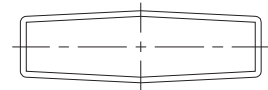

PHENOLIC — TAPPED (INCH & METRIC)

PART NO.	A	B	C DIA	D	E	F
CL-632-TK	2-1/2	2-1/2	2-1/2	2-1/2	1/4-20	5/8
CL-642-TK					5/16-18	
CL-652-TK					3/8-16	1/2
CL-654-TK					3/8-24	
CLM-642-TK					M8	5/8
CLM-652-TK					M10	1/2

THERMOPLASTIC — TAPPED (INCH & METRIC)

PART NO.	A	B	C DIA	D	E	F
CL-232-TK	1	7/8	1/2	3/8	1/4-20	7/16
CLM-232-TK					M6	
CL-432-TK	2	1-1/8	3/4	1/2	1/4-20	5/8
CL-442-TK					5/16-18	
CL-452-TK					3/8-16	1/2
CLM-432-TK					M6	
CLM-442-TK					M8	5/8
CL-6320-TK	2-1/2	1-1/4	3/4	5/8	1/4-20	5/8
CL-6420-TK					5/16-18	
CL-6520-TK					3/8-16	1/2
CLM-6420-TK					M8	
CLM-6520-TK					M10	1/2

QUARTER-TURN SCREWS

1215 STEEL, CARBURIZED-HARDENED, BLACK OXIDE FINISH

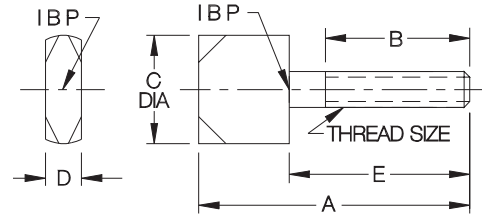
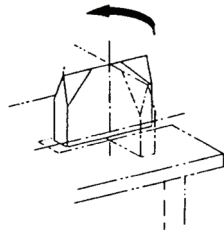

INCH

PART NO. HARDENED	PART NO. SOFT	THREAD PITCH	A	B	C DIA	D	E
CL-1-QTS	CL-10-QTS	#10-24	1-1/2	7/8	5/8	3/16	1
CL-2-QTS	CL-20-QTS	#10-32			1/2		
CL-3-QTS	CL-30-QTS	1/4-20	1-7/8	1	3/4	1/4	1-1/4
CL-4-QTS	CL-40-QTS	5/16-18	2-1/4	1-1/4	1	5/16	1-1/2
CL-5-QTS	CL-50-QTS	3/8-16	2-1/2			3/8	
CL-6-QTS	CL-60-QTS	1/2-13	2-3/4	1-1/2	1-1/4	1/2	1-3/4

Rotate screw 90 degrees (1/4 turn) to latch. Ideal for swing-away lids and jig plates. Beveled edges allow easy insertion into a slot. Also available soft (not carburized-hardened) for customizing as desired.

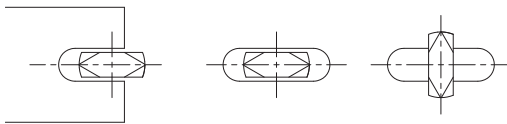

Use quarter-turn screws in either open or closed slots.

METRIC

PART NO.	THREAD SIZE	THREAD PITCH (mm)	A (mm)	B (mm)	C DIA (mm)	D (mm)	E (mm)
CLM-5-QTS	M5	.8	40	20	16	5	25
CLM-6-QTS	M6	1	50	25	19	6	30
CLM-8-QTS	M8	1.25	60	35	25.5	8	40
CLM-10-QTS	M10	1.5	65			10	
CLM-12-QTS	M12	1.75	70	40	32	12	45

HALF-TURN SCREWS

1215 STEEL, CARBURIZED-HARDENED, BLACK OXIDE FINISH

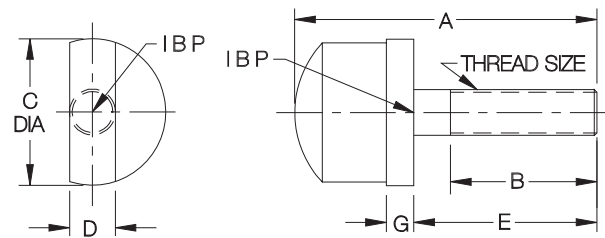
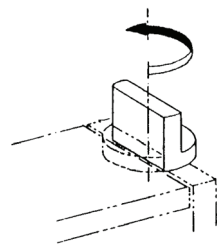

INCH

PART NO.	THREAD SIZE	A	B	C DIA	D	E	G
CL-1-HTS	#10-32	1-11/16	7/8	3/4	3/16	1	3/16
CL-2-HTS	1/4-20	2	1	3/4	1/4	1-1/4	
CL-3-HTS	5/16-18	2-1/16		1	5/16		
CL-4-HTS	3/8-16	2-11/16	11/2	1-1/16	3/8	1-3/4	1/4
CL-5-HT	1/2-13	2-3/4		1-1/4	1/2		

METRIC

PART NO.	THREAD SIZE	THREAD PITCH (mm)	A (mm)	B (mm)	C DIA (mm)	D (mm)	E (mm)	G (mm)
CLM-5-HTS	M5	.8	43	22	19	5	25	5
CLM-6-HTS	M6	1	49	24	19	6	30	5
CLM-8-HTS	M8	1.25	50	24	25.5	8	30	5
CLM-10-HTS	M10	1.5	69	39	27	10	45	6

Rotate screw 180 degrees (1/2 turn) to latch. Allows latching swing-away lids and jig plates without machining a slot.

BAR-HANDLE SCREW CLAMPS

STEEL: 1215 STEEL BODY, CARBURIZED HARDENED, BLACK OXIDE FINISH. 1215 STEEL HANDLE, BLACK OXIDE FINISH.
300-SERIES STAINLESS STEEL SPRING. STAINLESS: 300-SERIES STAINLESS STEEL.



Screw clamp with a sliding bar handle for excellent leverage. The bar can be moved to any position, for convenient tightening, and is held in place by light spring force. These screw clamps accept all standard feet for swivel screws (INFO+: see page 119 for foot dimensions and specifications). Type A and B feet are also available in Delrin®, by adding "N" to the part number (examples: CL-620-BHSAN, CL-620-BHSA-SN). Available in screw sizes from 5/16-18 to 5/8-11 (M8 to M16 in metric), each in several lengths.

3

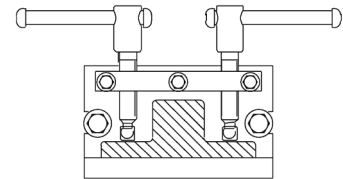
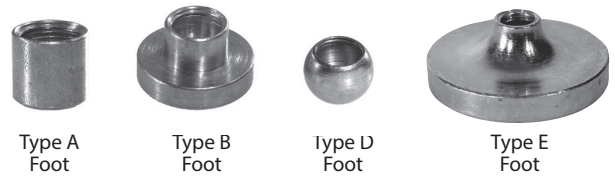
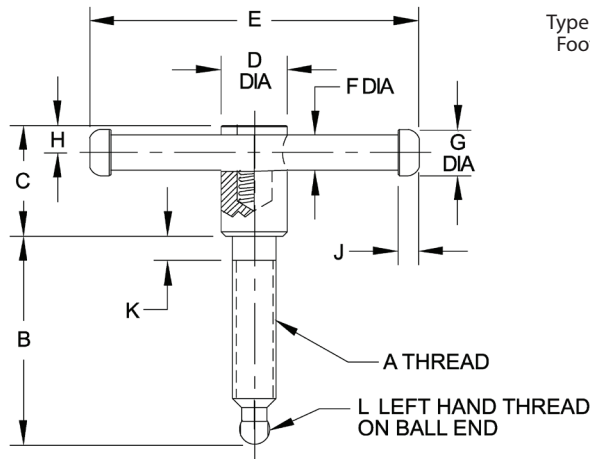

Sliding bar can be moved to any position for convenient tightening, such as when two clamps are close to each other.

GENERAL DIMENSIONS

A THREAD SIZE	C	D DIA	E	F DIA	G DIA	H	J	K	L
5/16-18 or M8	1-1/8	5/8	2-3/8	1/4	3/8	1/4	1/4	5/16	#12-28 LH
3/8-16 or M10	1-1/4	3/4	3-1/8	5/16	7/16	9/32	9/32	3/8	1/4-28 LH
1/2-13 or M12	1-3/8	13/16	3-15/16	3/8	1/2	11/32	11/32	3/8	5/16-24 LH
5/8-11 or M16	1-5/8	1	4-3/4	1/2	5/8	13/32	13/32	3/8	7/16-20 LH

STEEL (INCH)

A THREAD SIZE	B LENGTH	PART NO. WITHOUT FOOT	PART NO. WITH TYPE A SMALL FOOT	PART NO. WITH TYPE B LARGE FOOT	PART NO. WITH TYPE C VEE FOOT	PART NO. WITH TYPE D BALL FOOT	PART NO. WITH TYPE E EXTRA-LARGE FOOT
5/16-18	2	CL-520-BHS	CL-520-BHSA	CL-520-BHSB	CL-520-BHSC	CL-520-BHSD	—
	3	CL-530-BHS	CL-530-BHSA	CL-530-BHSB	CL-530-BHSC	CL-530-BHSD	—
3/8-16	2	CL-620-BHS	CL-620-BHSA	CL-620-BHSB	CL-620-BHSC	CL-620-BHSD	—
	3	CL-630-BHS	CL-630-BHSA	CL-630-BHSB	CL-630-BHSC	CL-630-BHSD	—
1/2-13	4	CL-640-BHS	CL-640-BHSA	CL-640-BHSB	CL-640-BHSC	CL-640-BHSD	—
	2	CL-820-BHS	CL-820-BHSA	CL-820-BHSB	CL-820-BHSC	CL-820-BHSD	CL-820-BHSE
5/8-11	3	CL-830-BHS	CL-830-BHSA	CL-830-BHSB	CL-830-BHSC	CL-830-BHSD	CL-830-BHSE
	4	CL-840-BHS	CL-840-BHSA	CL-840-BHSB	CL-840-BHSC	CL-840-BHSD	CL-840-BHSE
5/8-11	3	CL-1030-BHS	CL-1030-BHSA	CL-1030-BHSB	CL-1030-BHSC	CL-1030-BHSD	CL-1030-BHSE
	4	CL-1040-BHS	CL-1040-BHSA	CL-1040-BHSB	CL-1040-BHSC	CL-1040-BHSD	CL-1040-BHSE

CONTINUED ON NEXT PAGE

BAR-HANDLE SCREW CLAMPS

CONTINUED FROM PREVIOUS PAGE

STAINLESS STEEL (INCH)

5/16-18	2	CL-520-BHS	CL-520-BHSA	CL-520-BHSB	—	—	—
	3	CL-530-BHS	CL-530-BHSA	CL-530-BHSB	—	—	—
3/8-16	2	CL-620-BHS	CL-620-BHSA	CL-620-BHSB	—	—	—
	3	CL-630-BHS	CL-630-BHSA	CL-630-BHSB	—	—	—
1/2-13	2	CL-820-BHS	CL-820-BHSA	CL-820-BHSB	—	—	—
	3	CL-830-BHS	CL-830-BHSA	CL-830-BHSB	—	—	—
5/8-11	3	CL-1030-BHS	CL-1030-BHSA	CL-1030-BHSB	—	—	—
	4	CL-1040-BHS	CL-1040-BHSA	CL-1040-BHSB	—	—	—

STEEL (METRIC)

M8	1.97 (50mm)	CLM-850-BHS	CLM-850-BHSA	CLM-850-BHSB	CLM-850-BHSC	CLM-850-BHSD	—
	2.95 (75mm)	CLM-875-BHS	CLM-875-BHSA	CLM-875-BHSB	CLM-875-BHSC	CLM-875-BHSD	—
M10	1.97 (50mm)	CLM-1050-BHS	CLM-1050-BHSA	CLM-1050-BHSB	CLM-1050-BHSC	CLM-1050-BHSD	—
	3.94 (100mm)	CLM-10100-BHS	CLM-10100-BHSA	CLM-10100-BHSB	CLM-10100-BHSC	CLM-10100-BHSD	—
M12	1.97 (50mm)	CLM-1250-BHS	CLM-1250-BHSA	CLM-1250-BHSB	CLM-1250-BHSC	CLM-1250-BHSD	CLM-1250-BHSE
	3.94 (100mm)	CLM-12100-BHS	CLM-12100-BHSA	CLM-12100-BHSB	CLM-12100-BHSC	CLM-12100-BHSD	CLM-12100-BHSE
M16	2.76 (70mm)	CLM-1670-BHS	CLM-1670-BHSA	CLM-1670-BHSB	CLM-1670-BHSC	CLM-1670-BHSD	CLM-1670-BHSE
	4.33 (110mm)	CLM-16110-BHS	CLM-16110-BHSA	CLM-16110-BHSB	CLM-16110-BHSC	CLM-16110-BHSD	CLM-16110-BHSE

BAR-HANDLE NUTS

STEEL: 1215 STEEL BODY, CARBURIZED HARDENED, BLACK OXIDE FINISH. 1215 STEEL HANDLE, BLACK OXIDE FINISH. 300-SERIES STAINLESS STEEL SPRING. STAINLESS: 300-SERIES STAINLESS STEEL.



Extension nut with a sliding bar handle for excellent leverage. The bar can be moved to any position, for convenient tightening, and is held in place by light spring force. Available in thread sizes from 3/8-16 to 5/8-11 (M10 to M16 in metric).

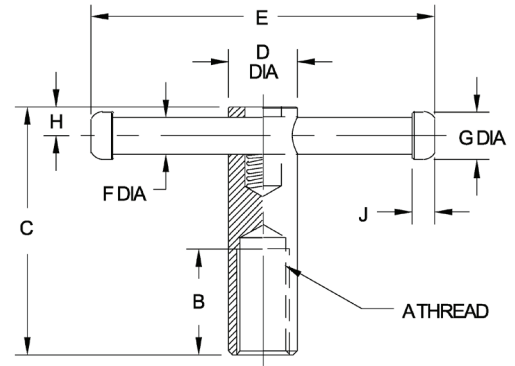

STEEL (INCH)

PART NO.	A	B	C	D DIA	E	F DIA	G DIA	H	J
CL-6-BHN	3/8-16	7/8	2-3/8	3/4	3-1/8	5/16	7/16	9/32	9/32
CL-8-BHN	1/2-13	1-1/8	2-3/4	13/16	3-15/16	3/8	1/2	11/32	5/16
CL-10-BHN	5/8-11	1-3/8	3-3/8	1	4-3/4	1/2	5/8	13/32	3/8

STAINLESS STEEL (INCH)

CL-6-BHN-S	3/8-16	7/8	2-3/8	3/4	3-1/8	5/16	7/16	9/32	9/32
CL-8-BHN-S	1/2-13	1-1/8	2-3/4	13/16	3-15/16	3/8	1/2	11/32	5/16
CL-10-BHN-S	5/8-11	1-3/8	3-3/8	1	4-3/4	1/2	5/8	13/32	3/8

STEEL (METRIC)

PART NO.	A THREAD	THREAD PITCH (mm)	B (mm)	C (mm)	D DIA (mm)	E (mm)	F DIA (mm)	G DIA (mm)	H (mm)	J (mm)
CLM-10-BHN	M10	1.5	20	60	19	80	8	11	7	7
CLM-12-BHN	M12	1.75	25	70	20	100	10	12.5	9	8
CLM-16-BHN	M16	2	35	85	25	120	12.5	16	10	10

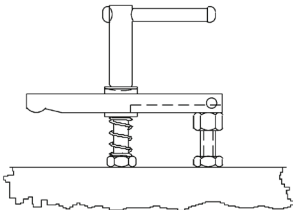

BAR-LOK QUICK-ACTING SCREW CLAMPS

1215 STEEL, CARBURIZED-HARDENED, ZINC PLATED YELLOW CHROMATE
 KNOB HANDLE: 319 ALUMINUM ALLOY

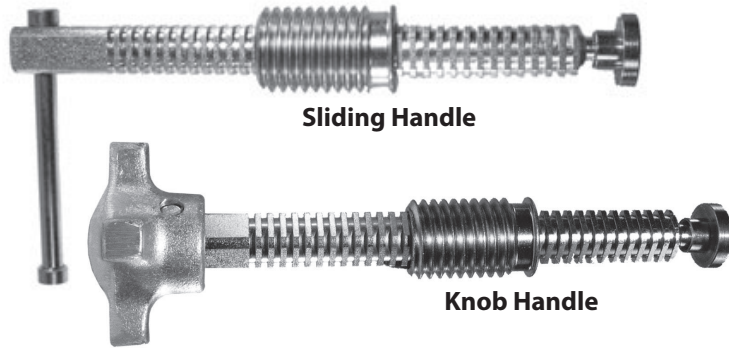

Sliding Handle

Knob Handle

Definitely the best quick-acting screw clamp available anywhere! This patented sliding-bar design works smoothly and positively – just slide the bar forward, then twist to apply force. As strong as a standard screw clamp, but much faster. Choose either a comfortable knob handle or a sliding handle for extra leverage. Available in 3/8", 1/2", and 5/8" bar sizes, each in a choice of several lengths and foot styles. Ball and foot are threaded to allow easy installation and removal, a lefthand thread to positively prevent backout when turning the screw counterclockwise. Once the threads clear during installation, the foot rotates and pivots freely (20° included angle).

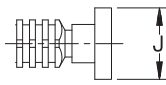
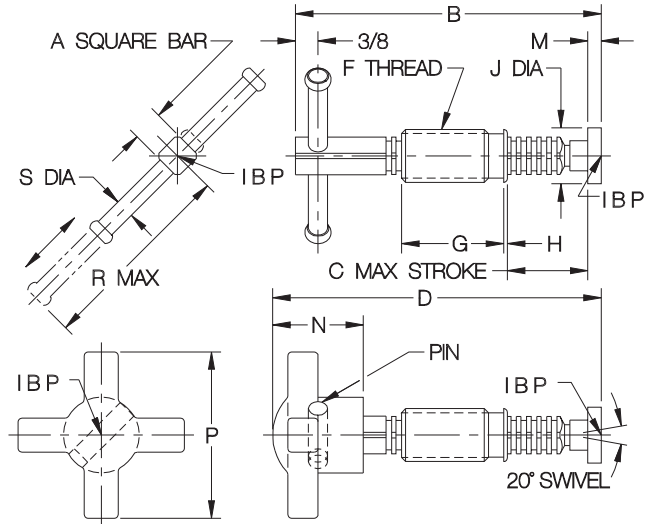

With standard foot:
 CL-14-BLK
 CL-14-BLKN (Delrin®)

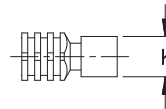

With small foot, add A:
 CL-14-BLKA
 CL-14-BLKAN (Delrin®)

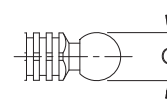

With ball foot, add -D:
 CL-14-BLKD

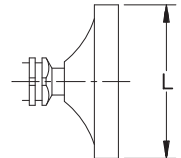

With large foot, add E:
 CL-14-BLKE

SLIDING HANDLE (INCH)

PART NO.	A	B	C	D	F THREAD	G	H	J DIA	K DIA	L DIA	M	N	P	Q	R	S DIA	OLD BAR-LOK NUMBER
CL-14-BLT	3/8	4	1-9/16	---	3/4-10	1-3/8	1/8	.750	.390	1.50	.187	---	---	.500	2-15/16	1/4	S-204-T
CL-15-BLT		5	2-9/16														S-205-T
CL-16-BLT		6	3-9/16														S-206-T
CL-25-BLT	1/2	5	2-3/16	---	7/8-9	1-11/16	1/16	.930	.500	2.00	.218	---	---	.625	3-5/16	5/16	M-205-T
CL-26-BLT		6	3-3/16														M-206-T
CL-28-BLT		8	5-3/16														M-208-T
CL-210-BLT		10	7-3/16														M-210-T
CL-212-BLT		12	9-3/16														M-212-T
CL-35-BLT	5/8	5	2-3/16	---	1-1/8-7	1-11/16	1/16	.930	.500	2.00	.218	---	---	.625	3-1/4	5/16	H-205-T
CL-36-BLT		6	3-3/16														H-206-T
CL-38-BLT		8	5-3/16														H-208-T
CL-310-BLT		10	7-3/16														H-210-T
CL-312-BLT		12	9-3/16														H-212-T

KNOB HANDLE (INCH)

CL-14-BLK	3/8	---	1-5/16	4-11/16	3/4-10	1-3/8	1/8	3/4	.390	1.50	.187	1-7/16	2-1/8	.500	---	---	---
CL-15-BLK			2-5/16	5-11/16													
CL-16-BLK			3-5/16	6-11/16													
CL-25-BLK	1/2	---	1-5/8	5-3/8	7/8-9	1-11/16	1/16	15/16	.500	2.00	.218	1-1/2	2-3/4	.625	---	---	---
CL-26-BLK			2-5/8	6-3/8													
CL-28-BLK			4-5/8	8-3/8													
CL-210-BLK			6-5/8	10-3/8													
CL-212-BLK			8-5/8	12-3/8													
CL-35-BLK	5/8	---	1-5/8	5-3/8	1-1/8-7	1-11/16	1/16	15/16	.500	2.00	.218	1-1/2	2-3/4	.625	---	---	---
CL-36-BLK			2-5/8	6-3/8													
CL-38-BLK			4-5/8	8-3/8													
CL-310-BLK			6-5/8	10-3/8													
CL-312-BLK			8-5/8	12-3/8													

BAR-LOK QUICK-ACTING SCREW CLAMPS

1215 STEEL, CARBURIZED-HARDENED, ZINC PLATED YELLOW CHROMATE
 KNOB HANDLE: 319 ALUMINUM ALLOY

3

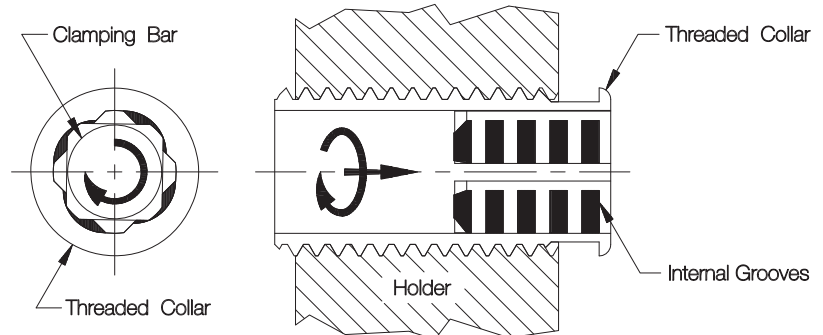
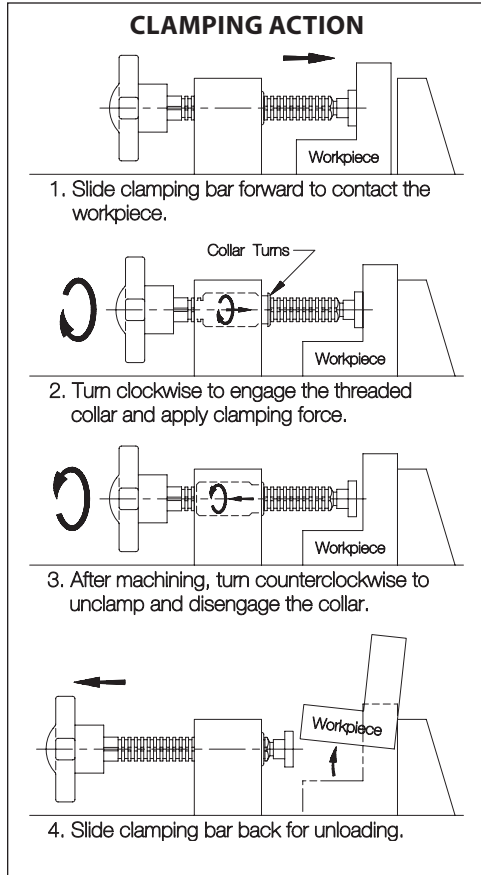

Clockwise

Turning the clamping bar clockwise engages internal grooves in the threaded collar. Both components then turn together as a single unit to apply screw force.

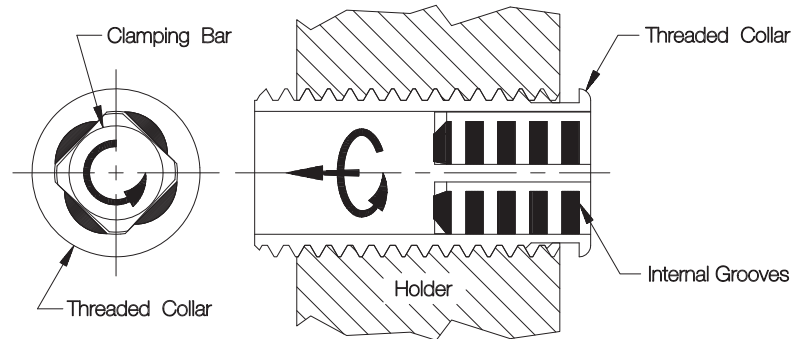

Counterclockwise

Turning the clamping bar clockwise engages internal grooves in the threaded collar. Both components then turn together as a single unit to apply screw force.



Mounting Block

Versatile mounting base made especially for Bar-Lok screw clamps. Attach with two Socket-Head Cap Screws. Two sets of mounting holes allow either base mounting or through-hole wall mounting.

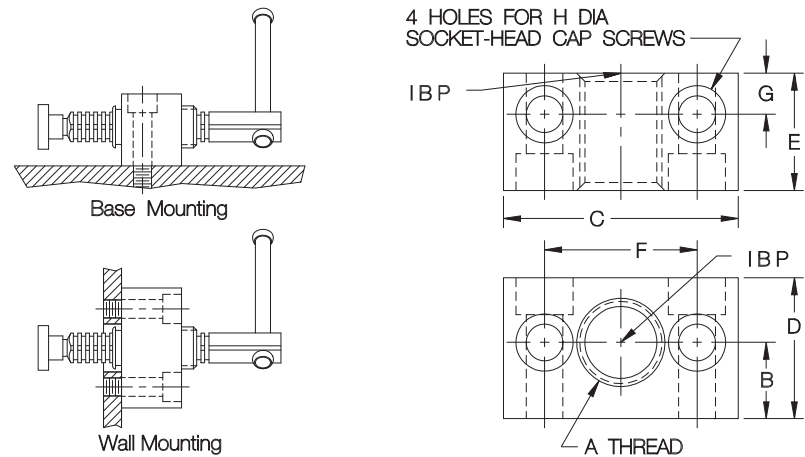

MOUNTING BLOCKS

PART NO.	A THREAD	B	C	D	E	F	G	H DIA
CL-1-BLM	3/4-10	13/16	2-1/8	1-3/8	1-1/4	1-3/8	7/16	5/16 OR M8
CL-2-BLM	7/8-9	1	2-1/2	1-1/2	1-1/2	1-5/8	1/2	3/8 OR M10
CL-3-BLM	1-1/8-7	1	3-1/8	1-7/8	1-1/2	2-1/8	1/2	1/2 OR M12

THIS IS NO ORDINARY CLAMP

Floating Clamp from
Carr Lane Mfg.



See Page 305 for more information

KNURLED HEAD SCREWS

STEEL: 1215, CARBURIZED-HARDENED, BLACK OXIDE FINISH.
 STAINLESS STEEL: 300-SERIES, PASSIVATED



Handy thumb screw. Knurled head provides a positive grip for finger tightening in light clamping applications.

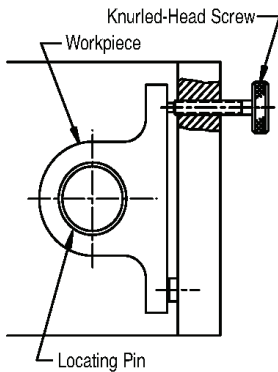

STEEL (INCH)

PART NO.	A THREAD	B	C DIA	D	E	F DIA	G	
CL-1-KHS	#10-24	1	3/4	1/4	1/4	.12	.09	
CL-2-KHS		1-1/2						
CL-3-KHS		2						
CL-1A-KHS	#10-32	1	1	5/16		.15	.12	
CL-1A-KHS-1		1-3/8						
CL-2A-KHS		1-1/2						
CL-2A-KHS-1		1-5/8						
CL-3A-KHS	2	1-1/8	3/8	7/16		.20	.16	
CL-4-KHS	1-1/2							
CL-4-KHS-1	1-3/8							
CL-4-KHS-2	1-3/4	1-1/4	1/2	7/16		.25	.19	
CL-5-KHS	2							
CL-6-KHS	2-1/2	3/8-16	2-1/2	3		3-1/2	.34	.25
CL-7-KHS	1-1/2							
CL-7-KHS-1	1-3/4	3/8-16	2	7/16	3/16	.25	.19	
CL-8-KHS	2							
CL-9-KHS	2-1/2	3/8-16	3	7/16	3/16	.25	.19	
CL-10-KHS	2							
CL-11-KH	2-1/2	3/8-16	3	7/16	3/16	.25	.19	
CL-12-KHS	3							
CL-13-KHS	3	1/2-13	3-1/2	1/2	.34	.25		
CL-14-KHS	3-1/2							

STAINLESS STEEL (INCH)

PART NO.	A THREAD	B	C DIA	D	E	F DIA	G
CL-23207	#10-32	3/4	1/2	3/16	1/8	.12	.09
CL-23210		1					
CL-23212		1-1/4					
CL-23215	1-1/2	1/4-20	1	5/16	1/8	.15	.12
CL-23507	3/4						
CL-23510	1						
CL-23512	1-1/4						
CL-23515	1-1/2	5/16-18	1-1/8	3/8	3/16	.20	.16
CL-23520	2						
CL-23615	1-1/2						
CL-23620	2	3/8-16	1-1/4	7/16	3/16	.25	.19
CL-23625	2-1/2						
CL-23820	2	3/8-16	1-1/4	7/16	3/16	.25	.19
CL-23825	2-1/2						
CL-23830	3						

STAINLESS STEEL (METRIC)

PART NO.	A THREAD	THREAD PITCH (mm)	B (mm)	C DIA (mm)	D (mm)	E (mm)	F DIA (mm)	G (mm)
CLM-1-KHS	M5	.8	25	19	6.5	6.5	3.4	2.7
CLM-2-KHS-1		.85	35					
CLM-2-KHS		.8	40					
CLM-3-KHS	50	25.5	8	4.4	3.3			
CLM-4-KHS	40							
CLM-4-KHS-1	45							
CLM-5-KHS	50							
CLM-6-KHS	65	M8	28.5	9.5	5.9		4.6	
CLM-7-KHS	40							
CLM-8-KHS-1	45							
CLM-8-KHS	50	M10	32	11	6.9		4.8	
CLM-9-KHS	65							
CLM-10-KHS	40	M12	90	12.5	8.9		6.3	
CLM-11-KHS	65							
CLM-12-KHS	75							
CLM-13-KHS	75	M12	90	12.5	8.9	6.3		
CLM-14-KHS	90							

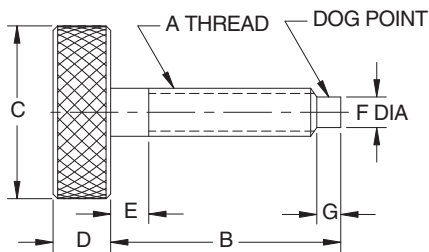

BODIES FOR SWIVEL SCREWS

STEEL: 1215 OR 1144, HEAT TREATED, ZINC PLATED YELLOW CHROMATE OR BLACK OXIDE FINISH
 STAINLESS STEEL: 300-SERIES



Socket Head

Swivel-screw bodies that accept any of the feet shown on the opposite page. Socket-head version allows applying strong clamping force using a hex wrench. **Patent no. 2,531,892.**

D LEFT HAND THD.

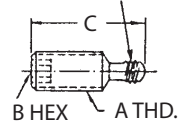

SOCKET HEAD (INCH)

PART NO. STEEL	PART NO. STEEL	PART NO. STEEL	A	B	C	D
ZINC PLATED	BLACK OXIDE	STAINLESS				
CL-1-BSS	CL-1-BSS-BO	—	1/4-20	1/8	15/32	#8-36 L.H.
CL-2-BSS	CL-2-BSS-BO	CL-2-BSS-S			23/32	
CL-3-BSS	CL-3-BSS-BO	CL-3-BSS-S			31/32	
CL-4-BSS	CL-4-BSS-BO	CL-4-BSS-S			1-15/32	
CL-5-BSS	CL-5-BSS-BO	—	5/16-18	5/32	23/32	#12-28 L.H.
CL-6-BSS	CL-6-BSS-BO	CL-6-BSS-S			31/32	
CL-7-BSS	CL-7-BSS-BO	CL-7-BSS-S			1-15/32	
CL-8-BSS	CL-8-BSS-BO	CL-8-BSS-S			1-31/32	
CL-9-BSS	CL-9-BSS-BO	—	3/8-16	3/16	11/16	1/4-28 L.H.
CL-10-BSS	CL-10-BSS-BO	—			15/16	
CL-11-BSS	CL-11-BSS-BO	CL-11-BSS-S			1-7/16	
CL-12-BSS	CL-12-BSS-BO	CL-12-BSS-S			1-15/16	
CL-13-BSS	CL-13-BSS-BO	CL-13-BSS-S	2-15/16	1/2-13	1/4	5/16-24 L.H.
CL-15-BSS	CL-15-BSS-BO	—	1-7/16			
CL-16-BSS	CL-16-BSS-BO	CL-16-BSS-S	1-15/16			
CL-17-BSS	CL-17-BSS-BO	CL-17-BSS-S	2-15/16			
CL-18-BSS	CL-18-BSS-BO	CL-18-BSS-S	3-15/16	5/8-11	5/16	7/16-20 L.H.
CL-20-BSS	CL-20-BSS-BO	—	1-15/16			
CL-21-BSS	CL-21-BSS-BO	—	2-15/16			
CL-22-BSS	CL-22-BSS-BO	—	3-15/16			
CL-23-BSS	CL-23-BSS-BO	—	4-15/16			

SOCKET HEAD (METRIC)

PART NO. STEEL	A	B	C	D
BLACK OXIDE				
CLM-1-BSS-BO	M6	3mm	.56	#8-36 L.H.
CLM-2-BSS-BO			.76	
CLM-3-BSS-BO			.95	
CLM-4-BSS-BO			1.54	
CLM-5-BSS-BO	M8	4mm	.74	#12-28 L.H.
CLM-6-BSS-BO			.94	
CLM-7-BSS-BO			1.53	
CLM-8-BSS-BO			1.92	
CLM-9-BSS-BO	M10	5mm	.73	1/4-28 L.H.
CLM-10-BSS-BO			.93	
CLM-11-BSS-BO			1.52	
CLM-12-BSS-BO			1.92	
CLM-13-BSS-BO	2.90	M12	6mm	5/16-24 L.H.
CLM-15-BSS-BO	1.52			
CLM-16-BSS-BO	1.91			
CLM-17-BSS-BO	2.89			
CLM-18-BSS-BO	3.88	M16	8mm	7/16-20 L.H.
CLM-20-BSS-BO	1.89			
CLM-21-BSS-BO	2.87			
CLM-22-BSS-BO	3.86			
CLM-23-BSS-BO	4.85			

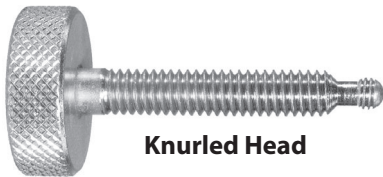

Knurled Head

Similar to the above screws, except with a knurled head for finger tightening.

H LEFT HAND THD.

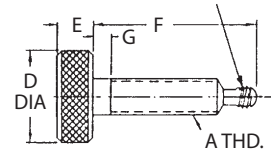

KNURLED HEAD (INCH)

PART NO. STEEL	PART NO. STEEL	PART NO. STEEL	A	D DIA	E	F	G	H
ZINC PLATED	BLACK OXIDE	STAINLESS						
CL-24-BSS	CL-24-BSS-BO	CL-24-BSS-S	1/4-20	1	5/16	31/32	1/8	#8-36 L.H.
CL-25-BSS	CL-25-BSS-BO	CL-25-BSS-S				1-15/32		
CL-26-BSS	CL-26-BSS-BO	CL-26-BSS-S				1-31/32		
CL-27-BSS	CL-27-BSS-BO	CL-27-BSS-S				2-31/32		
CL-28-BSS	CL-28-BSS-BO	—	5/16-18	1-1/8	3/8	31/32	3/16	#12-28 L.H.
CL-29-BSS	CL-29-BSS-BO	CL-29-BSS-S				1-15/32		
CL-30-BSS	CL-30-BSS-BO	CL-30-BSS-S				1-31/32		
CL-31-BSS	CL-31-BSS-BO	CL-31-BSS-S				2-31/32		
CL-33-BSS	CL-33-BSS-BO	—	3/8-16	1-1/4	7/16	1-7/16	3/16	1/4-28 L.H.
CL-34-BSS	CL-34-BSS-BO	CL-34-BSS-S				1-15/16		
CL-35-BSS	CL-35-BSS-BO	CL-35-BSS-S				2-15/16		
CL-36-BSS	CL-36-BSS-BO	CL-36-BSS-S				3-15/16		
CL-38-BSS	CL-38-BSS-BO	—	1/2-13	1-1/4	1/2	1-7/16	3/16	5/16-24 L.H.
CL-39-BSS	CL-39-BSS-BO	—				1-15/16		
CL-40-BSS	CL-40-BSS-BO	CL-40-BSS-S				2-15/16		
CL-41-BSS	CL-41-BSS-BO	CL-41-BSS-S				3-15/16		
CL-43-BSS	CL-43-BSS-BO	—	5/8-11	1-1/4	1/2	1-15/16	3/16	7/16-20 L.H.
CL-44-BSS	CL-44-BSS-BO	—				2-15/16		
CL-45-BSS	CL-45-BSS-BO	—				3-15/16		
CL-46-BSS	CL-46-BSS-BO	—				4-15/16		

KNURLED HEAD (METRIC)

PART NO. STEEL	A	D DIA	E	F	G	H
BLACK OXIDE						
CLM-24-BSS-BO	M6	1	5/16	.95	1/8	#8-36 L.H.
CLM-25-BSS-BO				1.54		
CLM-26-BSS-BO				1.94		
CLM-27-BSS-BO				2.92		
CLM-28-BSS-BO	M8	1-1/8	3/8	.94	3/16	#12-28 L.H.
CLM-29-BSS-BO				1.53		
CLM-30-BSS-BO				1.92		
CLM-31-BSS-BO				2.91		
CLM-33-BSS-BO	M10	1-1/4	7/16	1.52	3/16	1/4-28 L.H.
CLM-34-BSS-BO				1.92		
CLM-35-BSS-BO				2.90		
CLM-36-BSS-BO				3.88		
CLM-38-BSS-BO	M12	1-1/4	1/2	1.52	3/16	5/16-24 L.H.
CLM-39-BSS-BO				1.91		
CLM-40-BSS-BO				2.89		
CLM-41-BSS-BO				3.88		
CLM-43-BSS-BO	M16	1-1/4	1/2	1.89	3/16	7/16-20 L.H.
CLM-44-BSS-BO				2.88		
CLM-45-BSS-BO				3.86		
CLM-46-BSS-BO				4.85		

FEET FOR SWIVEL SCREWS

STEEL: (TYPES A, B, D, E), 1215 STEEL, ZINC PLATED YELLOW CHROMATE (BLACK OXIDE OPTIONAL)

STEEL (TYPE C): 1018 STEEL, CARBURIZED HARDENED, ZINC PLATED YELLOW CHROMATE (BLACK OXIDE OPTIONAL)

STAINLESS: 300-SERIES STAINLESS STEEL

DELRIN®: WHITE DELRIN® 500

Matching feet for the swivel-screw bodies on the opposite page. Types A, B, and D can be used with any body-thread size. Type E can be used with the largest two sizes.

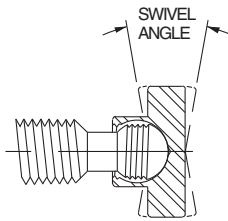

Ball and foot are threaded to allow easy installation and removal, a lefthand thread to positively prevent backout when turning the screw counterclockwise. Once the threads clear during installation, the foot rotates and pivots freely (20° included angle). Note: Delrin® feet are not threaded — they snap on and off.

3



**Type A
Small Foot**

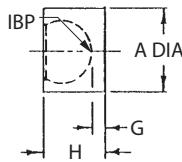

TYPE A — SMALL FOOT

PART NO. STEEL ZINC PLATED	PART NO. STEEL BLACK OXIDE	PART NO. STAINLESS STEEL	PART NO. DELRIN®	FITS BODY THREAD SIZE	A DIA	G	H
CL-1A-FSS	CL-1A-FSS-BO	CL-1A-FSS-S	CL-1A-FSSN	1/4-20 and M6	.187	.031	.200
CL-2A-FSS	CL-2A-FSS-BO	CL-2A-FSS-S	CL-2A-FSSN	5/16-18 and M8	.250	.046	.255
CL-3A-FSS	CL-3A-FSS-BO	CL-3A-FSS-S	CL-3A-FSSN	3/8-16 and M10	.298	.053	.315
CL-4A-FSS	CL-4A-FSS-BO	CL-4A-FSS-S	CL-4A-FSSN	1/2-13 and M12	.390	.058	.359
CL-5A-FSS	CL-5A-FSS-BO	CL-5A-FSS-S	CL-5A-FSSN	5/8-11 and M16	.500	.076	.470



**Type B
Large Foot**

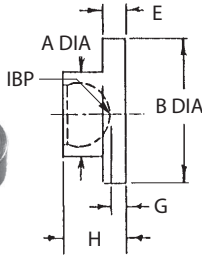

TYPE B — LARGE FOOT

PART NO. STEEL ZINC PLATED	PART NO. STEEL BLACK OXIDE	PART NO. STAINLESS STEEL	PART NO. DELRIN®	FITS BODY THREAD SIZE	A DIA	B DIA	E	G	H
CL-1B-FSS	CL-1B-FSS-BO	CL-1B-FSS-S	CL-1B-FSSN	1/4-20 and M6	.187	.375	.125	.131	.300
CL-2B-FSS	CL-2B-FSS-BO	CL-2B-FSS-S	CL-2B-FSSN	5/16-18 and M8	.250	.500	.156	.141	.350
CL-3B-FSS	CL-3B-FSS-BO	CL-3B-FSS-S	CL-3B-FSSN	3/8-16 and M10	.298	.562	.187	.177	.437
CL-4B-FSS	CL-4B-FSS-BO	CL-4B-FSS-S	CL-4B-FSSN	1/2-13 and M12	.390	.750	.187	.119	.420
CL-5B-FSS	CL-5B-FSS-BO	CL-5B-FSS-S	CL-5B-FSSN	5/8-11 and M16	.500	.930	.218	.121	.515



**Type D
Ball Foot**

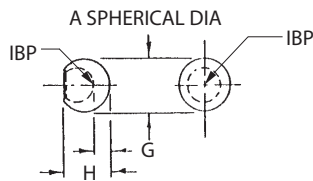

TYPE D — BALL FOOT

PART NO. STEEL ZINC PLATED	PART NO. STEEL BLACK OXIDE	FITS BODY THREAD SIZE	A DIA	G	H
CL-1D-FSS	CL-1D-FSS-BO	1/4-20 and M6	.250	.051	.220
CL-2D-FSS	CL-2D-FSS-BO	5/16-18 and M8	.312	.071	.280
CL-3D-FSS	CL-3D-FSS-BO	3/8-16 and M10	.375	.064	.325
CL-4D-FSS	CL-4D-FSS-BO	1/2-13 and M12	.500	.144	.443
CL-5D-FSS	CL-5D-FSS-BO	5/8-11 and M16	.620	.137	.531



**Type E
Extra-Large Foot**

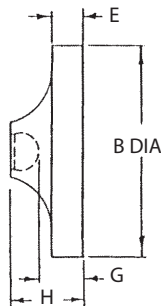

TYPE E — EXTRA-LARGE FOOT

PART NO. STEEL ZINC PLATED	PART NO. STEEL BLACK OXIDE	FITS BODY THREAD SIZE	B DIA	E	G	H
CL-4E-FSS	CL-4E-FSS-BO	1/2-13 and M12	1.50	1/4	.26	.56
CL-5E-FSS	CL-5E-FSS-BO	5/8-11 and M16	2.00	5/16	.31	.70

SWIVEL HEAD SCREWS

BODY: 1215 STEEL, CARBURIZED-HARDENED, ZINC PLATED YELLOW CHROMATE (OR 300-SERIES STAINLESS STEEL)
FOOT: 1215 STEEL, ZINC PLATED YELLOW CHROMATE (OR 300-SERIES STAINLESS STEEL, OR DELRIN®)

The steel version is optionally available with a black oxide finish by adding "-BO" to the part number (example: CL-1-SHS-BO). Type A and B feet are optionally available in Delrin® by adding "N" to the part number (examples: CL-1-SHSN, CL-1-SHS-BON, CL-1-SHS-SN).

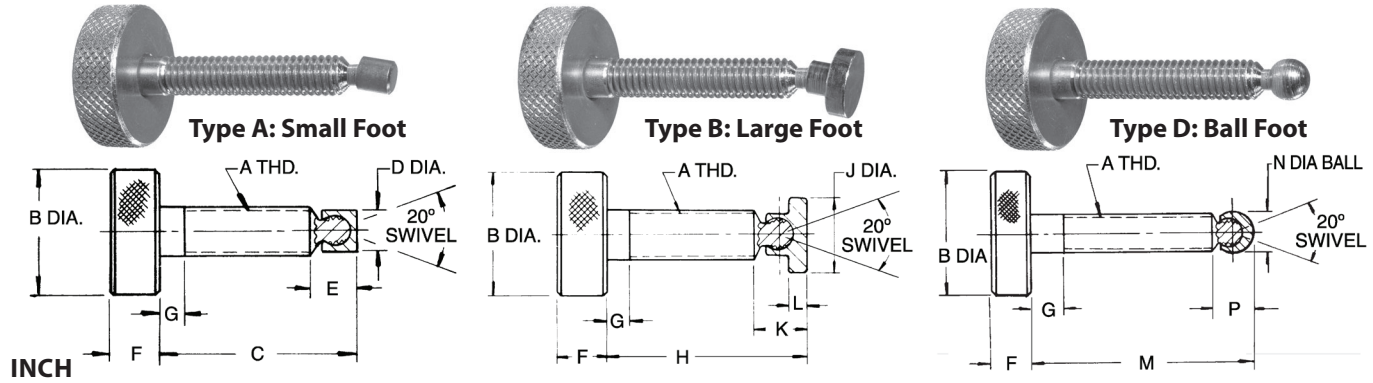

TYPE A STEEL PART NO.*	TYPE A STAINLESS PART NO.	TYPE B STEEL PART NO.*	TYPE B STAINLESS PART NO.	TYPE D STEEL PART NO.*	A	B DIA	C	D DIA	E	F	G	H	J DIA	K	L	M	N	P
CL-1-SHS	CL-1-SHS-S	CL-17-SHS	CL-17-SHS-S	CL-47-SHS	1/4-20	1	1	3/16	9/32	5/16	1/8	1-3/32	3/8	23/64	1/8	1-1/32	1/4	5/16
CL-2-SHS	CL-2-SHS-S	CL-18-SHS	CL-18-SHS-S	CL-48-SHS			1-1/2					1-19/32				1-17/32		
CL-3-SHS	CL-3-SHS-S	CL-19-SHS	CL-19-SHS-S	CL-49-SHS			2					2-3/32				2-1/32		
CL-33-SHS	CL-33-SHS-S	CL-40-SHS	CL-40-SHS-S	CL-50-SHS			3					3-3/32				3-1/32		
CL-4-SHS	—	CL-20-SHS	—	CL-51-SHS	5/16-18	1-1/8	1	1/4	11/32	3/8	3/16	1-3/32	1/2	27/64	5/32	1-1/64	5/16	23/64
CL-5-SHS	CL-5-SHS-S	CL-21-SHS	CL-21-SHS-S	CL-52-SHS			1-1/2					1-19/32				1-33/64		
CL-6-SHS	CL-6-SHS-S	CL-22-SHS	CL-22-SHS-S	CL-53-SHS			2					2-3/32				2-1/64		
CL-34-SHS	CL-34-SHS-S	CL-41-SHS	CL-41-SHS-S	CL-54-SHS			3					3-3/32				3-1/64		
CL-8-SHS	—	CL-24-SHS	—	CL-56-SHS	3/8-16	1-1/4	1-1/2	19/64	3/8	7/16	3/16	1-5/8	9/16	5/8	3/16	1-9/16	3/8	7/16
CL-9-SHS	CL-9-SHS-S	CL-25-SHS	CL-25-SHS-S	CL-57-SHS			2					2-1/8				2-1/16		
CL-35-SHS	CL-35-SHS-S	CL-42-SHS	CL-42-SHS-S	CL-58-SHS			3					3-1/8				3-1/16		
CL-36-SHS	CL-36-SHS-S	CL-43-SHS	CL-43-SHS-S	CL-59-SHS			4					4-1/8				4-1/16		
CL-11-SHS	—	CL-27-SHS	—	CL-61-SHS	1/2-13	1-1/4	1-1/2	13/32	15/32	1/2	3/16	1-9/16	3/4	17/32	3/16	1-19/32	1/2	9/16
CL-12-SHS	—	CL-28-SHS	—	CL-62-SHS			2					2-1/16				2-3/32		
CL-13-SHS	CL-13-SHS-S	CL-29-SHS	CL-29-SHS-S	CL-63-SHS			3					3-1/16				3-3/32		
CL-37-SHS	CL-37-SHS-S	CL-44-SHS	CL-44-SHS-S	CL-64-SHS			4					4-1/16				4-3/32		
CL-15-SHS	—	CL-31-SHS	—	CL-66-SHS	5/8-11	1-1/4	2	1/2	5/8	1/2	3/16	2-3/64	15/16	21/32	7/32	2-1/8	5/8	11/16
CL-16-SHS	—	CL-32-SHS	—	CL-67-SHS			3					3-3/64				3-1/8		
CL-38-SHS	—	CL-45-SHS	—	CL-68-SHS			4					4-3/64				4-1/8		
CL-39-SHS	—	CL-46-SHS	—	CL-69-SHS			5					5-3/64				5-1/8		

METRIC

CLM-1-SHS-BO	—	CLM-17A-SHS-BO	—	CLM-47-SHS-BO	M6	1	.98	3/16	9/32	5/16	1/8	1.08	3/8	23/64	1/8	1.03	1/4	5/16
CLM-2-SHS-BO	—	CLM-18A-SHS-BO	—	CLM-48-SHS-BO			1.57					1.67				1.62		
CLM-3-SHS-BO	—	CLM-19-SHS-BO	—	CLM-49-SHS-BO			1.97					2.07				2.02		
CLM-4-SHS-BO	—	CLM-40-SHS-BO	—	CLM-50-SHS-BO			2.95					3.05				3.00		
CLM-5-SHS-BO	—	CLM-20-SHS-BO	—	CLM-51-SHS-BO	M8	1-1/8	.98	1/4	11/32	3/8	3/16	1.08	1/2	27/64	5/32	1.05	5/16	23/64
CLM-6-SHS-BO	—	CLM-21-SHS-BO	—	CLM-52-SHS-BO			1.57					1.67				1.64		
CLM-7-SHS-BO	—	CLM-22-SHS-BO	—	CLM-53-SHS-BO			1.97					2.06				2.03		
CLM-8-SHS-BO	—	CLM-41-SHS-BO	—	CLM-54-SHS-BO			2.95					3.05				3.02		
CLM-9-SHS-BO	—	CLM-24-SHS-BO	—	CLM-56-SHS-BO	M10	1-1/4	1.57	19/64	3/8	7/16	3/16	1.70	9/16	5/8	3/16	1.61	3/8	7/16
CLM-10-SHS-BO	—	CLM-25-SHS-BO	—	CLM-57-SHS-BO			1.97					2.10				2.01		
CLM-11-SHS-BO	—	CLM-42-SHS-BO	—	CLM-58-SHS-BO			2.95					3.08				2.99		
CLM-12-SHS-BO	—	CLM-43-SHS-BO	—	CLM-59-SHS-BO			3.94					4.06				3.97		
CLM-11A-SHS-BO	—	CLM-27-SHS-BO	—	CLM-61-SHS-BO	M12	1-1/4	1.57	13/32	15/32	1/2	3/16	1.64	3/4	17/32	3/16	1.69	1/2	9/16
CLM-12A-SHS-BO	—	CLM-28-SHS-BO	—	CLM-62-SHS-BO			1.97					2.03				2.08		
CLM-13-SHS-BO	—	CLM-29-SHS-BO	—	CLM-63-SHS-BO			2.95					3.01				3.06		
CLM-14-SHS-BO	—	CLM-44-SHS-BO	—	CLM-64-SHS-BO			3.94					4.00				4.05		
CLM-15-SHS-BO	—	CLM-31-SHS-BO	—	CLM-66-SHS-BO	M16	1-1/4	1.97	1/2	5/8	1/2	3/16	2.01	15/16	21/32	7/32	2.06	5/8	11/16
CLM-16-SHS-BO	—	CLM-32-SHS-BO	—	CLM-67-SHS-BO			2.95					3.00				3.05		
CLM-17-SHS-BO	—	CLM-45-SHS-BO	—	CLM-68-SHS-BO			3.94					3.98				4.03		
CLM-18-SHS-BO	—	CLM-46-SHS-BO	—	CLM-69-SHS-BO			4.92					4.97				5.02		

* Inch sizes are available zinc plated or with black oxide finish. Metric sizes are available only with black oxide finish (-BO only).

SWIVEL SCREW CLAMPS

BODY: 1215 OR 1144 STEEL, HEAT TREATED, ZINC PLATED YELLOW CHROMATE (OR 300-SERIES STAINLESS STEEL)

FOOT: 1215 STEEL, ZINC PLATED YELLOW CHROMATE (OR 300-SERIES STAINLESS STEEL, OR DELRIN®)

The steel version is optionally available with black oxide finish by adding "-BO" to the part number (example: CL-2-SSC-BO). Type A and B feet are optionally available in Delrin® by adding "N" to the part number (examples: CL-2-SSCN, CL-2-SSC-BON, CL-2-SSC-SN).



Type A: Small Foot



Type B: Large Foot



Type D: Ball Foot

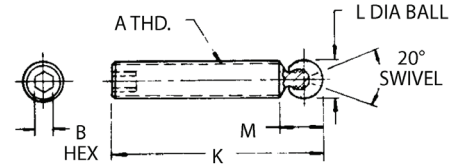
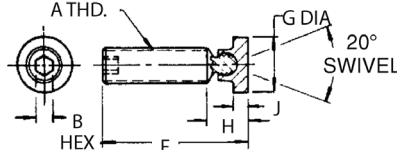
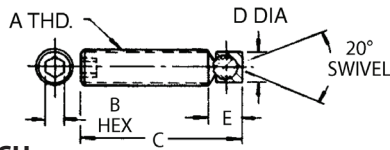

INCH

TYPE A STEEL PART NO.*	TYPE A STAINLESS PART NO.	TYPE B STEEL PART NO.*	TYPE B STAINLESS PART NO.	TYPE D STEEL PART NO.*	A	B	C	D DIA	E	F	G DIA	H	J	K	L DIA	M
CL-1-SSC	—	CL-20-SSC	—	CL-47-SSC	1/4-20	1/8	1/2	3/16	9/32	19/32	3/8	23/64	1/8	.69	1/4	5/16
CL-2-SSC	CL-2-SSC-S	CL-21-SSC	CL-21-SSC-S	CL-48-SSC			3/4			27/32				.89		
CL-3-SSC	CL-3-SSC-S	CL-22-SSC	CL-22-SSC-S	CL-49-SSC			1			1-3/32				1.08		
CL-4-SSC	CL-4-SSC-S	CL-23-SSC	CL-23-SSC-S	CL-50-SSC			1-1/2			1-19/32				1.67		
CL-5-SSC	—	CL-24-SSC	—	CL-51-SSC	5/16-18	5/32	3/4	1/4	11/32	27/32	1/2	27/64	5/32	.88	5/16	23/64
CL-6-SSC	CL-6-SSC-S	CL-25-SSC	CL-25-SSC-S	CL-52-SSC			1			1-3/32				1.08		
CL-7-SSC	CL-7-SSC-S	CL-26-SSC	CL-26-SSC-S	CL-53-SSC			1-1/2			1-19/32				1.67		
CL-8-SSC	CL-8-SSC-S	CL-27-SSC	CL-27-SSC-S	CL-54-SSC			2			2-3/32				2.06		
CL-9-SSC	—	CL-28-SSC	—	CL-55-SSC	3/8-16	3/16	3/4	19/64	3/8	7/8	9/16	5/8	3/16	.91	3/8	7/16
CL-10-SSC	—	CL-29-SSC	—	CL-56-SSC			1			1-1/8				1.11		
CL-11-SSC	CL-11-SSC-S	CL-30-SSC	CL-30-SSC-S	CL-57-SSC			1-1/2			1-5/8				1.70		
CL-12-SSC	CL-12-SSC-S	CL-31-SSC	CL-31-SSC-S	CL-58-SSC			2			2-1/8				2.10		
CL-39-SSC	CL-39-SSC-S	CL-43-SSC	CL-43-SSC-S	CL-59-SSC	1/2-13	1/4	3	13/32	15/32	3-1/8	3/4	17/32	3/16	3.08	1/2	9/16
CL-14-SSC	—	CL-33-SSC	—	CL-61-SSC			1-1/2			1-9/16				1.64		
CL-15-SSC	CL-15-SSC-S	CL-34-SSC	CL-34-SSC-S	CL-62-SSC			2			2-1/16				2.03		
CL-16-SSC	CL-16-SSC-S	CL-35-SSC	CL-35-SSC-S	CL-63-SSC			3			3-1/16				3.01		
CL-40-SSC	CL-40-SSC-S	CL-44-SSC	CL-44-SSC-S	CL-64-SSC	5/8-11	5/16	4	1/2	5/8	4-1/16	15/16	21/32	7/32	4.00	5/8	11/16
CL-18-SSC	—	CL-37-SSC	—	CL-66-SSC			2			2-3/64				2.01		
CL-19-SSC	—	CL-38-SSC	—	CL-67-SSC			3			3-3/64				2.99		
CL-41-SSC	—	CL-45-SSC	—	CL-68-SSC			4			4-3/64				3.98		
CL-42-SSC	—	CL-46-SSC	—	CL-69-SSC	5	5-3/64	4.97									

METRIC

CLM-1-SSC-BO	—	CLM-20A-SSC-BO	—	CLM-47-SSC-BO	M6	3mm	.59	3/16	9/32	.69	3/8	23/64	1/8	.69	1/4	5/16
CLM-2-SSC-BO	—	CLM-21A-SSC-BO	—	CLM-48-SSC-BO			.79			.89				.89		
CLM-3-SSC-BO	—	CLM-22-SSC-BO	—	CLM-49-SSC-BO			.98			1.08				1.08		
CLM-4-SSC-BO	—	CLM-23-SSC-BO	—	CLM-50-SSC-BO			1.57			1.67				1.67		
CLM-5-SSC-BO	—	CLM-24-SSC-BO	—	CLM-51-SSC-BO	M8	4mm	.79	1/4	11/32	.88	1/2	27/64	5/32	.88	5/16	23/64
CLM-6-SSC-BO	—	CLM-25-SSC-BO	—	CLM-52-SSC-BO			.98			1.08				1.08		
CLM-7-SSC-BO	—	CLM-26-SSC-BO	—	CLM-53-SSC-BO			1.57			1.67				1.67		
CLM-8-SSC-BO	—	CLM-27-SSC-BO	—	CLM-54-SSC-BO			1.97			2.06				2.06		
CLM-9-SSC-BO	—	CLM-28-SSC-BO	—	CLM-55-SSC-BO	M10	5mm	.79	19/64	3/8	.91	9/16	5/8	3/16	.91	3/8	7/16
CLM-10-SSC-BO	—	CLM-29-SSC-BO	—	CLM-56-SSC-BO			.98			1.11				1.11		
CLM-11-SSC-BO	—	CLM-30-SSC-BO	—	CLM-57-SSC-BO			1.57			1.70				1.70		
CLM-12-SSC-BO	—	CLM-31-SSC-BO	—	CLM-58-SSC-BO			1.97			2.10				2.10		
CLM-13-SSC-BO	—	CLM-32-SSC-BO	—	CLM-59-SSC-BO	M12	6mm	2.95	13/32	15/32	3.08	3/4	17/32	3/16	3.08	1/2	9/16
CLM-14-SSC-BO	—	CLM-33-SSC-BO	—	CLM-61-SSC-BO			1.57			1.64				1.64		
CLM-15-SSC-BO	—	CLM-34-SSC-BO	—	CLM-62-SSC-BO			1.97			2.03				2.03		
CLM-16-SSC-BO	—	CLM-35-SSC-BO	—	CLM-63-SSC-BO			2.95			3.01				3.01		
CLM-17-SSC-BO	—	CLM-36-SSC-BO	—	CLM-64-SSC-BO	M16	8mm	3.94	1/2	5/8	4.00	15/16	21/32	7/32	4.00	5/8	11/16
CLM-18-SSC-BO	—	CLM-37-SSC-BO	—	CLM-66-SSC-BO			1.97			2.01				2.01		
CLM-19-SSC-BO	—	CLM-38-SSC-BO	—	CLM-67-SSC-BO			2.95			2.99				2.99		
CLM-20-SSC-BO	—	CLM-39-SSC-BO	—	CLM-68-SSC-BO			3.94			3.98				3.98		
CLM-21-SSC-BO	—	CLM-40-SSC-BO	—	CLM-69-SSC-BO	4.92	4.97	4.97									

* Inch sizes are available zinc plated or with black oxide finish. Metric sizes are available only with black oxide finish (-BO only).

BALL-END THRUST SCREWS

BODY: ALLOY STEEL, BLACK OXIDE FINISH
BALL: 440C STAINLESS STEEL OR WHITE DELRIN® 500



**Rolling Ball
(Stainless Steel)**

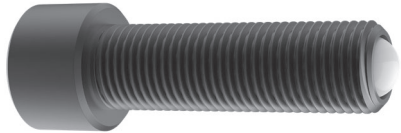

**Rolling Ball
(Delrin)**

New item!

Ball-End Thrust Screws are heavy-duty screw clamps with a hardened stainless-steel ball contained in the end. Available with either a spherical rolling ball or a swivel ball with a flat contact surface. Both ball options are optionally available in Delrin material. These thrust screws have a large head and large hex-socket for excellent strength.

The rolling-ball version shown above is available in thread sizes from 1/4-20 to 5/8-11 (M6 to M16 in metric), each in a choice of two lengths.



**Swivel Ball with Flat
(Stainless Steel)**



**Swivel Ball with Flat
(Delrin)**

The swivel-ball version shown here is available in thread sizes from 3/8-16 to 5/8-11 (M10 to M16 in metric), each in a choice of two lengths.

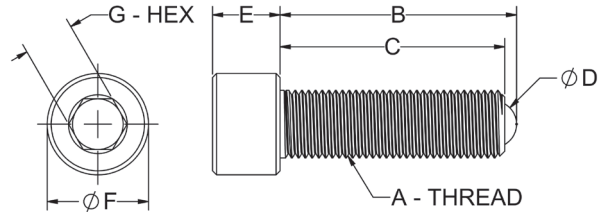

ROLLING BALL (INCH)

PART NO.		A THREAD	B	C	D DIA	E	F DIA	G
STAINLESS STEEL BALL	DELRIN BALL							
CL-4-BTS-1.00	CL-4-BTSN-1.00	1/4-20	1.03	1	5/32	.25	.38	3/16
CL-4-BTS-2.00	CL-4-BTSN-2.00	1/4-20	2.03	2	5/32	.25	.38	3/16
CL-6-BTS-2.00	CL-6-BTSN-2.00	3/8-16	2.06	2	1/4	.38	.56	5/16
CL-6-BTS-3.00	CL-6-BTSN-3.00	3/8-16	3.06	3	1/4	.38	.56	5/16
CL-8-BTS-3.00	CL-8-BTSN-3.00	1/2-13	3.12	3	11/32	.50	.75	3/8
CL-8-BTS-4.00	CL-8-BTSN-4.00	1/2-13	4.12	4	11/32	.50	.75	3/8
CL-80-BTS-1.75	CL-80-BTSN-1.75	1/2-20 Fine	1.87	1-3/4	11/32	.50	.75	3/8
CL-10-BTS-4.00	CL-10-BTSN-4.00	5/8-11	4.15	4	7/16	.63	.94	1/2
CL-10-BTS-5.00	CL-10-BTSN-5.00	5/8-11	5.15	5	7/16	.63	.94	1/2

ROLLING BALL (METRIC)

PART NO.		A THREAD	THREAD PITCH (mm)	B (mm)	C (mm)	D DIA (mm)	E (mm)	F DIA (mm)	G (mm)
STAINLESS STEEL BALL	DELRIN BALL								
CLM-6-BTS-25	CLM-6-BTSN-25	M6	1	26	25	3.97	6	10	5
CLM-6-BTS-50	CLM-6-BTSN-50	M6	1	51	50	3.97	6	10	5
CLM-10-BTS-50	CLM-10-BTSN-50	M10	1.5	52.4	50	7.14	10	16	8
CLM-10-BTS-75	CLM-10-BTSN-75	M10	1.5	77.4	75	7.14	10	16	8
CLM-12-BTS-75	CLM-12-BTSN-75	M12	1.75	77.7	75	8.73	12	18	10
CLM-12-BTS-100	CLM-12-BTSN-100	M12	1.75	102.7	100	8.73	12	18	10
CLM-16-BTS-100	CLM-16-BTSN-100	M16	2	103.9	100	11.11	16	24	14
CLM-16-BTS-125	CLM-16-BTSN-125	M16	2	128.9	125	11.11	16	24	14

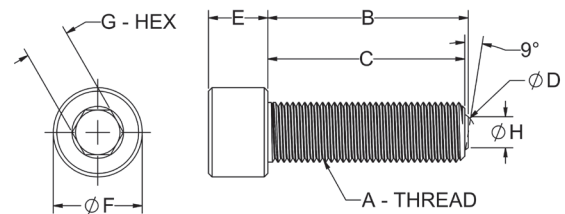

SWIVEL BALL WITH FLAT (INCH)

PART NO.		A THREAD	B	C	D DIA	E	F DIA	G	H DIA
STAINLESS STEEL BALL	DELRIN BALL								
CL-6-BTSF-2.00	CL-6-BTSFN-2.00	3/8-16	2.03	2	1/4	.38	.56	5/16	.16
CL-6-BTSF-3.00	CL-6-BTSFN-3.00	3/8-16	2.03	3	1/4	.38	.56	5/16	.16
CL-8-BTSF-3.00	CL-8-BTSFN-3.00	1/2-13	3.06	3	11/32	.50	.75	3/8	.24
CL-8-BTSF-4.00	CL-8-BTSFN-4.00	1/2-13	4.06	4	11/32	.50	.75	3/8	.24
CL-80-BTSF-1.75	CL-80-BTSFN-1.75	1/2-20 Fine	1.81	1-3/4	11/32	.50	.75	3/8	.24
CL-10-BTSF-4.00	CL-10-BTSFN-4.00	5/8-11	4.06	4	7/16	.63	.94	1/2	.35
CL-10-BTSF-5.00	CL-10-BTSFN-5.00	5/8-11	5.06	5	7/16	.63	.94	1/2	.35

SWIVEL BALL WITH FLAT (METRIC)

PART NO.		A THREAD	THREAD PITCH (mm)	B (mm)	C (mm)	D DIA (mm)	E (mm)	F DIA (mm)	G (mm)
STAINLESS STEEL BALL	DELRIN BALL								
—	CLM-6-BTSN-25	M6	1	26	25	3.97	6	10	5
—	CLM-6-BTSN-50	M6	1	51	50	3.97	6	10	5
CLM-10-BTSF-50	CLM-10-BTSN-50	M10	1.5	51.1	50	7.14	10	16	8
CLM-10-BTSF-75	CLM-10-BTSN-75	M10	1.5	76.1	75	7.14	10	16	8
CLM-12-BTSF-75	CLM-12-BTSN-75	M12	1.75	76.5	75	8.73	12	18	10
CLM-12-BTSF-100	CLM-12-BTSN-100	M12	1.75	101.5	100	8.73	12	18	10
CLM-16-BTSF-100	CLM-16-BTSN-100	M16	2	101.6	100	11.11	16	24	14
CLM-16-BTSF-125	CLM-16-BTSN-125	M16	2	126.6	125	11.11	16	24	14

KNURLED KNOBS

STEEL: 1215, CARBURIZED-HARDENED, BLACK OXIDE FINISH.
 STAINLESS STEEL: 300-SERIES, PASSIVATED

3



High-quality knurled-head knob provides a positive grip for quick finger tightening in light clamping applications. Available in steel with a black oxide finish or stainless steel.

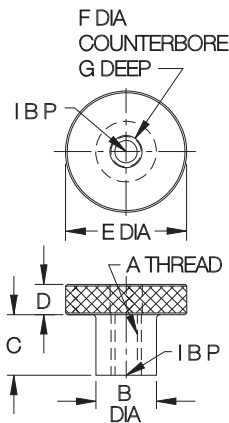

STEEL (INCH)

PART NO.	A	B DIA	C	D	E DIA	F DIA	G
CL-4-KK	1/4-20	5/8	1/2	1/4	1	NONE	NONE
CL-5-KK	5/16-18	5/8	1/2	5/16	1-1/4		
CL-6-KK	3/8-16	3/4	5/8	1/2	1-1/4		
CL-8-KK	1/2-13	1	3/4	1/2	1-1/2		

STAINLESS STEEL (INCH)

PART NO.	A	B DIA	C	D	E DIA	F DIA	G
CL-16312	#10-24	3/8	1/4	3/16	1/2	NONE	NONE
CL-16322			1/2			13/64	1/4
CL-16314			1/4	3/16	1	NONE	NONE
CL-16324			1/2			13/64	1/4
CL-16412	#10-32	3/8	1/4	3/16	1/2	NONE	NONE
CL-16422			1/2			13/64	1/4
CL-16414			1/4	3/16	1	NONE	NONE
CL-16424			1/2			13/64	1/4
CL-16513	1/4-20	1/2	1/4	1/4	3/4	NONE	NONE
CL-16514			1/4	1/4		1	NONE
CL-16524			1/2		17/64		1/4
CL-16534			3/4	1/2			
CL-16625	5/16-18	5/8	1/2	5/16	1-1/4	21/64	1/4
CL-16635			3/4			1/2	
CL-16725	3/8-16	3/4	1/2	3/8	1-1/4	25/64	1/4
CL-16735			3/4			1/2	
CL-8-KK-S	1/2-13	1	3/4	1/2	1-1/2	NONE	NONE

STEEL (METRIC)

PART NO.	A THREAD	THREAD PITCH (mm)	B DIA (mm)	C (mm)	D (mm)	E DIA (mm)	F DIA	G
CLM-5-KK	M5	.8	10	7.5	4	20	None	None
CLM-6-KK	M6	1	12	10	5	24		
CLM-8-KK	M8	1.25	16	12	6	30		
CLM-10-KK	M10	1.5						
CLM-12-KK	M12	1.75	20	15	8	40		

STAINLESS STEEL (METRIC)

PART NO.	A THREAD	THREAD PITCH (mm)	B DIA (mm)	C (mm)	D (mm)	E DIA (mm)	F DIA	G
CLM-6-KK-S	M6	1	12	10	5	24	None	None
CLM-10-KK-S	M10	1.5	20	15	8	36		

ADJUSTABLE-TORQUE THUMB SCREWS

SCREW: 1215 STEEL, CARBURIZED-HARDENED, BLACK OXIDE FINISH

KNOB: 1215 STEEL, BLACK OXIDE FINISH

SPRING: MUSIC WIRE OR STAINLESS STEEL 302

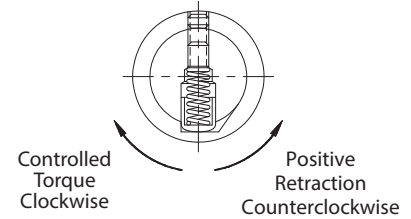

Knurled-head thumb screw that exerts positive, repeatable force. Clockwise, the knob declutches and turns freely when you reach the desired torque. Counterclockwise, the knob locks for positive retraction. Adjustable-Torque Thumb Screws are furnished with your choice of swivel foot, and a Knurled Check Nut.

To set desired force, first remove the outer cover screw at the side of the knob, to expose the adjustment screw. Next, insert a hex wrench to turn the adjustment screw until desired torque is achieved. Reinstall the outer cover screw when finished. Torque can be adjusted from 3 to 6 inch-lbs, resulting in a contact force of 10 to 125 lbs, but these values are approximate. Force can vary +/- 30% depending on lubrication and other operating conditions.

Choice of four foot types. Adjustable-Torque Thumb Screws use our patented left-hand-thread swivel-foot system. The ball end of the body screws into the foot for easy installation and removal. Once the ball threads pass beyond the foot threads, the foot can rotate and pivot freely (20° total angle). Foot threads are left-hand to positively prevent accidental backout during use. Delrin® feet are optional for types A and B. To order with a Delrin® foot, add "N" to the part number, e.g. CL-415-TSAN. Note: Delrin® feet are not threaded – they snap on and off.

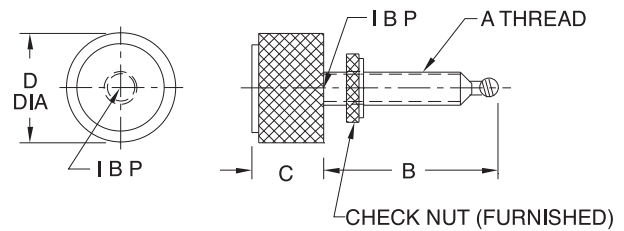

INCH

PART NO.				A	B	C	D DIA	ADJUSTMENT RANGE	
DOG POINT	A FOOT	B FOOT	D FOOT					TORQUE (IN.-LBS.)	END FORCE (LBS)*
CL-312-TS	—	—	—	#10-24	1-1/4	21/32	15/16	3-6	10-125
CL-312A-TS	—	—	—	#10-32					
—	CL-415-TSA	CL-415-TSB	CL-415-TSD	1/4-20	1-1/2				
—	CL-425-TSA	CL-425-TSB	CL-425-TSD		2-1/2				
—	CL-517-TSA	CL-517-TSB	CL-517-TSD	5/16-18	1-3/4				
—	CL-527-TSA	CL-527-TSB	CL-527-TSD		2-3/4				
—	CL-620-TSA	CL-620-TSB	CL-620-TSD	3/8-16	2				
—	CL-630-TSA	CL-630-TSB	CL-630-TSD		3				
—	CL-820-TSA	CL-820-TSB	CL-820-TSD	1/2-13	2				
—	CL-830-TSA	CL-830-TSB	CL-830-TSD		3				
—	CL-1020-TSA	CL-1020-TSB	CL-1020-TSD	5/8-11	2				
—	CL-1030-TSA	CL-1030-TSB	CL-1030-TSD		3				

METRIC

PART NO.				A THREAD	THREAD PITCH (mm)	B (mm)	C (mm)	D DIA (mm)	ADJUSTMENT RANGE	
DOG POINT	A FOOT	B FOOT	D FOOT						TORQUE (Nm)	END FORCE (N)
CLM-5-TS	—	—	—	M5	.8	30	16.5	24	.3 - .7	50 - 550
—	CLM-6-TSA	CLM-6-TSB	CLM-6-TSD	M6	1	64				
—	CLM-8-TSA	CLM-8-TSB	CLM-8-TSD	M8	1.25	69				
—	CLM-10-TSA	CLM-10-TSB	CLM-10-TSD	M10	1.5	74				
—	CLM-12-TSA	CLM-12-TSB	CLM-12-TSD	M12	1.75	73				
—	CLM-16-TSA	CLM-16-TSB	CLM-16-TSD	M16	2					

* End force can vary +/- 30% depending on lubrication and other operating conditions.

ADJUSTABLE-TORQUE KNOBS

KNOB: 1215 STEEL, BLACK OXIDE FINISH
 SPRING: 17-7 PH STAINLESS STEEL

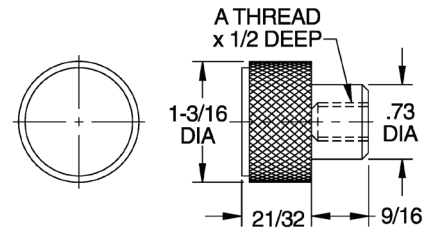
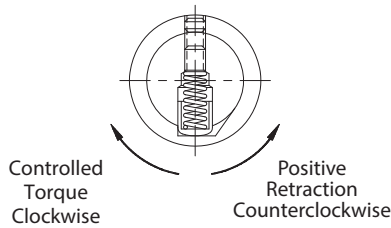
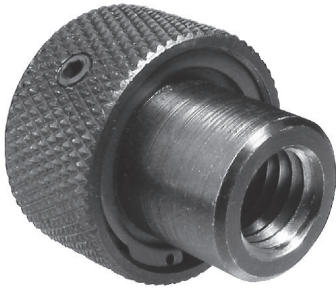

INCH

PART NO.	A	ADJUSTMENT RANGE	
		TORQUE (IN.-LBS)	END FORCE (LBS)*
CL-4-ATK	1/4-20	3-6	10-125
CL-5-ATK	5/16-18		10-125
CL-6-ATK	3/8-16		10-125
CL-8-ATK	1/2-13		10-125

Knurled knob that exerts positive, repeatable force. Clockwise, the knob declutches and turns freely when you reach the desired torque. Counterclockwise, the knob locks for positive retraction. Can be used as a controlled-torque nut, or as a thumb screw by installing a custom-made screw in the tapped hole.

To set desired force, first remove the outer cover screw at the side of the knob, to expose the adjustment screw. Next, insert a hex wrench to turn the adjustment screw until desired torque is achieved. Reinstall the outer cover screw when finished. Torque can be adjusted from 3 to 6 inch-lbs, resulting in a contact force of 10 to 125 lbs, but these values are approximate. Force can vary +/- 30% depending on lubrication and other operating conditions.

METRIC

PART NO.	A THREAD	THREAD PITCH (mm)	ADJUSTMENT RANGE	
			TORQUE (Nm)	END-FORCE (N)
CLM-6-ATK	M6	1	.3 - .7	50 - 550
CLM-8-ATK	M8	1.25	.3 - .7	50 - 550
CLM-10-ATK	M10	1.5	.3 - .7	50 - 550
CLM-12-ATK	M12	1.75	.3 - .7	50 - 550

QUICK-ACTING KNURLED KNOBS

1215 STEEL, BLACK OXIDE FINISH

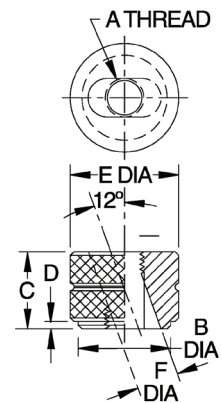
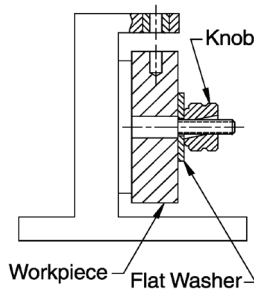

INCH

PART NO.	A	B DIA	C	D	E DIA	F DIA
CL-1-QKK	#10-24	1/2	7/16	1/16	5/8	7/32
CL-2-QKK	1/4-20	5/8	9/16		3/4	9/32
CL-3-QKK	5/16-18	3/4	5/8	3/4	7/8	11/32
CL-4-QKK	3/8-16	7/8	1/8		1	13/32
CL-5-QKK	1/2-13	1			1-1/8	17/32

Quick-acting knob that slides in and out of clamping position, ideal when the knob must be completely removed for loading. Tilt knob to slide in, then straighten to engage threads and tighten. To remove, loosen knob, then tilt to slide out. For full strength, use a stud that extends slightly beyond the knob, to engage all threads.

METRIC

PART NO.	A THREAD	THREAD PITCH (mm)	B DIA (mm)	C (mm)	D (mm)	E DIA (mm)	F DIA (mm)
CLM-5-QKK	M5	.8	13	11	2	16	6
CLM-6-QKK	M6	1	16	14		19	7
CLM-8-QKK	M8	1.25	19	16		22	9
CLM-10-QKK	M10	1.5	22		3	25.5	10.5
CLM-12-QKK	M12	1.75	25	19	3	28.5	12.5

KNURLED KNOBS

KNOB: BLACK PHENOLIC PLASTIC OR THERMOPLASTIC, WITH BRASS INSERT
 STUD: MILD STEEL, ZINC PLATED CLEAR CHROMATE

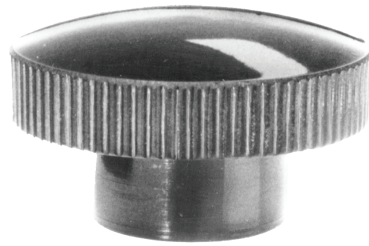

5/16-18 CL-642-KTK
 3/8-16 CL-652-KTK
 M8 CLM-642-KTK
 M10 CLM-652-KTK



1/4-20 CL-532-KTK
 5/16-18 CL-542-KTK
 M6 CLM-532-KTK
 M8 CLM-542-KTK

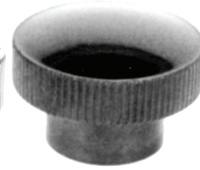

#10-32 CL-424-KTK
 1/4-20 CL-432-KTK
 M5 CLM-422-KTK
 M6 CLM-432-KTK



#10-32 CL-324-KTK
 1/4-20 CL-332-KTK
 M5 CLM-322-KTK



#10-32 CL-124-KTK



#6-32 CL-202-KTK
 #8-32 CL-212-KTK

Thermoplastic — Tapped

Phenolic — Tapped

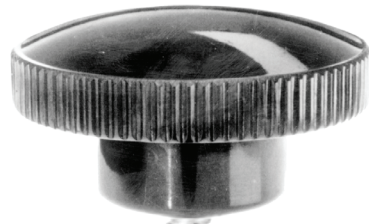

Phenolic — Stud Type

3/8-16 X 1 CL-652-KTK-16
 M10 X 25mm CLM-652-KTK-25



1/4-20 X 1/2 CL-532-KTK-8
 5/16-18 X 1 CL-542-KTK-16
 M8 X 25mm CLM-542-KTK-25



1/4-20 X 1 CL-432-KTK-16
 M6 X 25mm CLM-432-KTK-25

#8-32 X 1/2 CL-312-KTK-8
 #10-32 X 1/2 CL-324-KTK-8
 #10-32 X 1 CL-324-KTK-16
 1/4-20 X 1/2 CL-332-KTK-8
 M5 X 20mm CLM-322-KTK-20

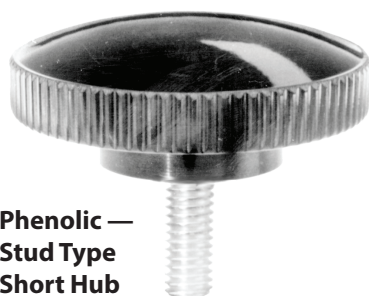

Phenolic — Stud Type Short Hub

3/8-16 X 1 CL-656-KTK-16



#6-32 X 3/4 CL-406-KTK-12
 1/4-20 X 3/4 CL-436-KTK-12

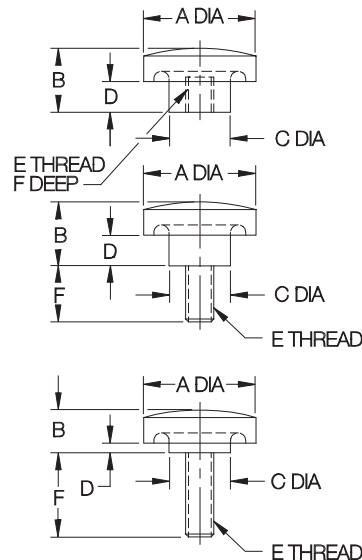

Knurled head provides a positive grip for finger tightening in light clamping applications. Choice of six knob sizes. Molded-in brass insert provides superior thread strength. Also available with a molded-in clamping stud. Non-standard thread sizes, or other lengths of molded-in studs are available in quantities of 500 and above.

THERMOPLASTIC — TAPPED (INCH)

PART NO.	A DIA	B	C DIA	D	E	F
CL-202-KTK	3/4	15/32	5/8	1/4	#6-32	5/16
CL-212-KTK					#9-32	

PHENOLIC — TAPPED (INCH & METRIC)

CL-124-KTK	5/8	9/16	1/2	—	#10-32	5/16
CL-324-KTK	3/4	7/32	7/16	1/16	#10-32	5/16
CL-332-KTK					1/4-20	
CLM-322-KTK					M5	
CL-424-KTK	1	21/32	5/8	5/16	#10-32	5/16
CL-432-KTK					1/4-20	
CLM-432-KTK					M6	3/8
CL-542-KTK	1-3/8	25/32	3/4	3/8	5/16-18	7/16
CLM-532-KTK					M6	
CL-642-KTK	1-7/8	1	1	1/2	5/16-18	7/16
CL-652-KTK					3/8-16	

PHENOLIC — STUD TYPE (INCH & METRIC)

CL-312-KTK-8	3/4	17/32	7/16	1/16	#8-32	1/2
CL-324-KTK-8					#10-32	
CL-324-KTK-16					1/4-20	1/2
CL-332-KTK-8	1	21/32	5/8	5/16	1/4-20	1
CL-432-KTK-16					1/4-20	
CLM-432-KTK-25					M6	.98
CL-532-KTK-8	1-3/8	25/32	3/4	3/8	1/4-20	1/2
CL-652-KTK-16	1-7/8	1	1	1/2	3/8-16	1

PHENOLIC — STUD TYPE, SHORT HUB (INCH)

CL-436-KTK-12	1	13/32	1/2	1/16	1/4-20	3/4
CL-656-KTK-16	1-7/8	3/4	1	1/4	3/8-16	1

HAND-WHEEL MODIFICATIONS

3

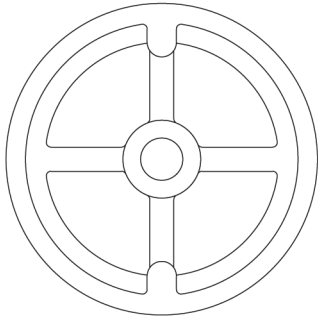

Bored Hole

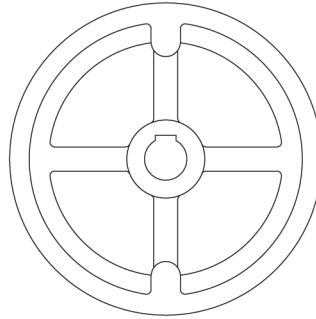

Bored Hole with Keyway

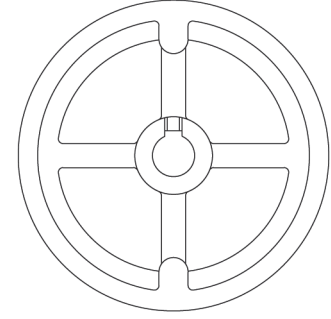

Bored Hole with Setscrew Hole over Keyway

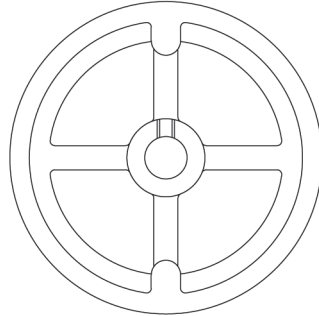

Bored Hole with Setscrew Hole

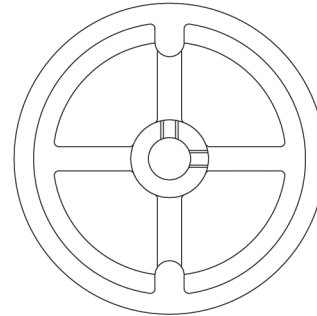

Bored Hole with 2 Setscrew Holes at 90°

BORE SIZE

HAND WHEEL DIA	STANDARD BORE SIZE (+0/+.002)	MAXIMUM BORE SIZE
4	.375	.750
5	.375	1.000
6	.500	1.125
8	.625	1.375
10	.625	1.500
12	.750	2.000

KEYWAYS & SETSCREWS

BORE SIZE	STANDARD SQUARE KEYWAY	STANDARD SETSCREW HOLE
.375-.438	3/32	#10-32
.439-.562	1/8	#10-32
.563-.875	3/16	1/4-20
.876-1.250	1/4	5/16-18
1.251-1.375	5/16	3/8-16
1.376-1.750	3/8	3/8-16
1.751-2.000	1/2	1/2-13

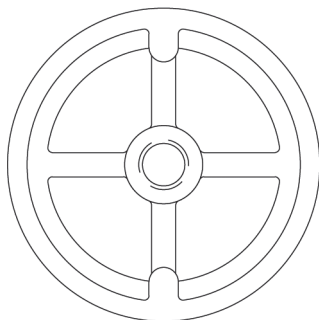

TAPPED HOLE

HAND WHEEL DIA	AVAILABLE THREAD SIZES
4	3/8 to 3/4, M10 to M20
5	3/8 TO 1, M10 to M24
6	1/2 to 1-1/4, M12 to M30
8	1/2 to 1-3/8, M12 to M36
10	5/8 to 1-1/2, M16 to M36
12	3/4 to 2, M20 to M48

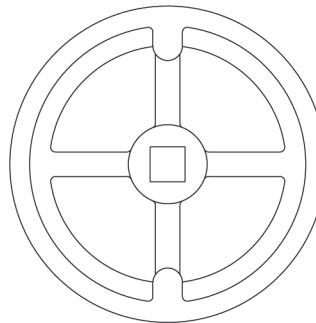

SQUARE HOLE

HAND WHEEL DIA	AVAILABLE SQUARE HOLE SIZES
4	1/2
5	1/2, 5/8
6	1/2, 5/8
8	1/2, 5/8
10	1/2, 5/8
12	1/2, 5/8

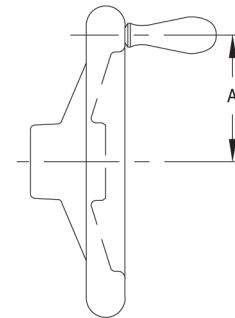

HANDLE INSTALLATION

HAND WHEEL DIA	A
4	1-9/16
5	2
6	2-1/2
8	3-1/4
10	4-3/16
12	5-1/8

HAND WHEELS

CAST IRON PER ASTM-A48 CLASS 30 OR 319 ALUMINUM ALLOY



**Angled-Spoke
Rounded Design
Cast Iron or Aluminum**

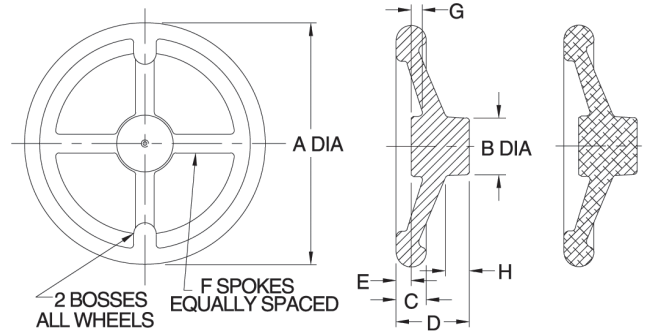

**Cast Iron
HWAF** **Aluminum
HWAFA**

Utility-grade Hand Wheels that can be easily customized for any application. Wide range of sizes from 4 to 12" in diameter. Choose either cast iron for maximum strength, or aluminum for light weight.

ANGLED SPOKES

PART NO. CAST IRON	PART NO. ALUMINUM	A DIA	B DIA	C	D	E	F	G	H	J DIA	HANDLE		
											SIZE	SOLID	REVOLVING
CL-4-HWAF	CL-4-HWAFA	4	1-1/4	5/8	1-11/16	1/8	4	9/32	3/4	11/16	SIZE 2	INFO+: SEE PAGE 138	INFO+: SEE PAGES 139-141
CL-5-HWAF	CL-5-HWAFA	5	1-1/2	3/4	1-7/8	3/8		5/16		1			
CL-6-HWAF	CL-6-HWAFA	6	1-5/8		1	2	13/32	8	3/8	13/16	1	SIZE 4	INFO+: SEE PAGE 138
CL-8-HWAF	CL-8-HWAFA	8	1-7/8	2-7/16		1/2	1-3/8						
CL-10-HWAF	CL-10-HWAFA	10	2-1/4	1	3-1/32	11/16	8	7/16	1-1/16	1-3/4	SIZE 5	INFO+: SEE PAGE 138	INFO+: SEE PAGES 139-141
CL-12-HWAF	CL-12-HWAFA	12	3		4-3/32	1-1/16		1-3/4	2-1/2				



**Straight-Spoke
Rounded Design
Cast Iron or Aluminum**

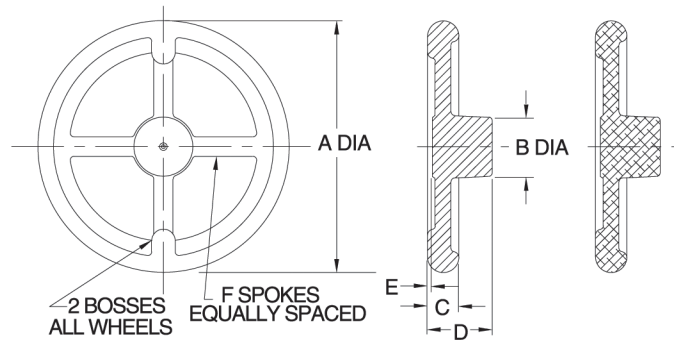

**Cast Iron
HWSF** **Aluminum
HWSFA**

Same as the Hand Wheels shown above, except with straight spokes for a flatter profile.

STRAIGHT SPOKES

PART NO. CAST IRON	PART NO. ALUMINUM	A DIA	B DIA	C	D	E	F	J DIA	HANDLE		
									SIZE	SOLID	REVOLVING
CL-4-HWSF	CL-4-HWSFA	4	1-1/4	5/8	1-11/16	1/8	4	11/16	SIZE 2	INFO+: SEE PAGE 138	INFO+: SEE PAGES 139-141
CL-5-HWSF	CL-5-HWSFA	5	1-1/2	3/4				1			
CL-6-HWSF	CL-6-HWSFA	6	1-5/8		1	1-13/16	5/32	8	1	SIZE 4	INFO+: SEE PAGE 138
CL-8-HWSF	CL-8-HWSFA	8	1-7/8	2-1/16		1-3/8					
CL-10-HWSF	CL-10-HWSFA	10	2-1/4	1	2-1/2	1/8	8	1-3/4	SIZE 5	INFO+: SEE PAGE 138	INFO+: SEE PAGES 139-141
CL-12-HWSF	CL-12-HWSFA	12	3		3-1/4			2-1/2			

HAND WHEELS

CAST IRON, CHROME PLATED



**Angled-Spoke Rounded Design
Cast Iron
Chrome Plated with Polished Rim**

High-quality Hand Wheel with contemporary design. Beautiful chrome-plated finish with a polished rim. Hand Wheel is bored to the standard shaft diameter for its size, and is also tapped for a standard Solid or Revolving Handle. Order handle separately. See table below for matching rounded-design handle (stainless steel). To use without a handle, see table below to order a matching Handle Plug, for the tapped hole (chrome-plated steel).

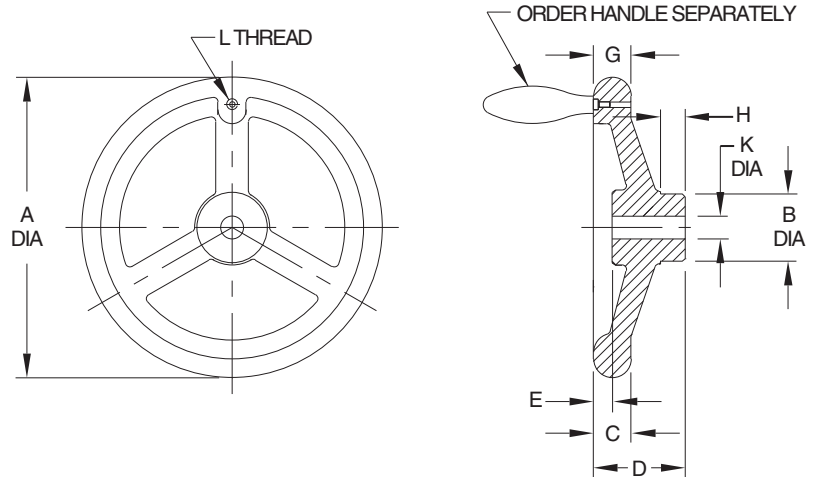

Hand wheels up through 8" diameter have three spokes; sizes 10" and larger have five spokes. Sizes 8" and larger have a wavy inside rim for better gripping.

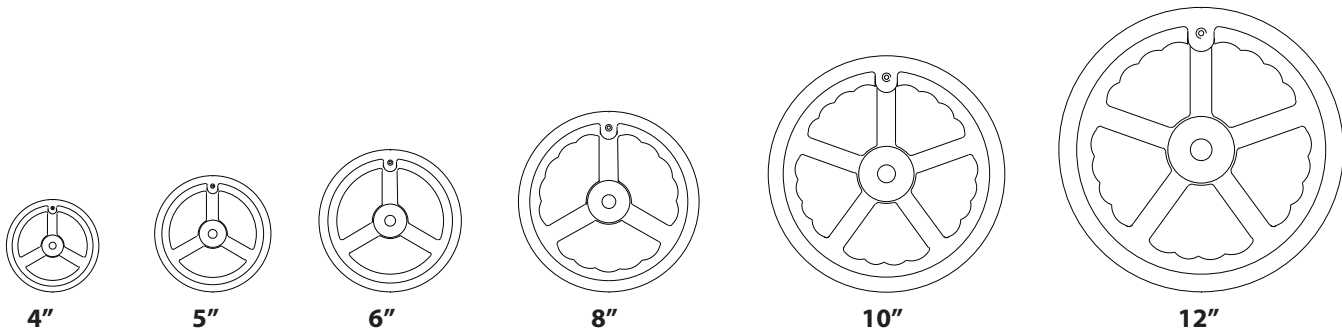

ORDER HAND WHEEL AND SOLID/REVOLVING HANDLE SEPARATELY

PART NO. WITH TAPPED HOLE FOR HANDLE	A DIA	B DIA	C	D	E	H	K DIA	L	MATCHING HANDLE			HANDLE PLUG
									SIZE	SOLID	REVOLVING	
CL-40-HWAR	4	1-1/8	9/16	1-1/2	7/16	1/2	3/8	1/4-20	SIZE 2	CL-250-SH-S	CL-250-RH-S	CL-2-HW-PLUG
CL-50-HWAR	5	1-1/4	19/32	1-5/8								
CL-60-HWAR	6	1-3/8	21/32	1-13/16	9/16	9/16	1/2	5/16-18	SIZE 3	CL-350-SH-S	CL-350-RH-S	CL-3-HW-PLUG
CL-80-HWAR	8	1-21/32	7/8	2-3/16	11/16	5/8	5/8	3/8-16	SIZE 4	CL-450-SH-S	CL-450-RH-S	CL-4-HW-PLUG
CL-100-HWAR	10	1-7/8	15/16	2-3/8	23/32	3/4						
CL-120-HWAR	12	2-5/32	1	2-1/2	23/32	7/8	3/4	1/2-13	SIZE 5	CL-550-SH-S	CL-550-RH-S	CL-5-HW-PLUG

HAND WHEELS

ALUMINUM, GRAVITY DIE CAST



High-quality Hand Wheel with two spokes, with contemporary design. Rim is machined and highly polished on all sides. Spokes are shot blasted to a satin finish. These Hand Wheels are bored to the standard shaft diameter for their size, and are tapped for a Solid or Revolving Handle (also available without tapped hole for handle). Rim is concentric and square to the bore. Order Solid or Revolving Handle separately. Matching square-design stainless steel handles are recommended.

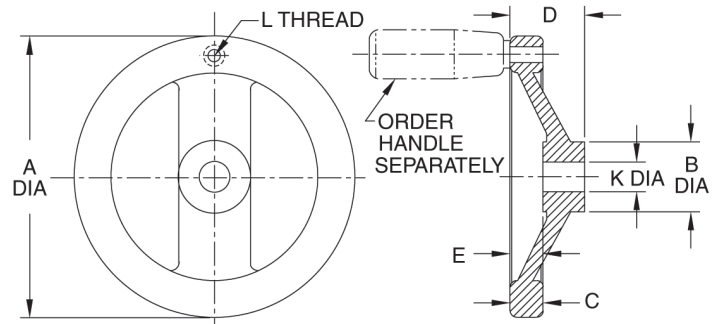

TWO-SPOKE SQUARE DESIGN — ALUMINUM

PART NO. WITH TAPPED HOLE FOR HANDLE	A DIA	B DIA	C	D	E	K DIA	L	HANDLE		
								SIZE	SOLID	REVOLVING
CL-50-HWTS-A	4.92	1.22	.59	1.30	.59	.375	1/4-20	SIZE 2	SEE PAGE 138	SEE PAGES 139-141
CL-60-HWTS-A	6.30	1.42	.71	1.54	.75	.500	5/16-18	SIZE 3		
CL-80-HWTS-A	7.87	1.65	.81	1.77	.83	.625	3/8-16	SIZE 4		
CL-100-HWTS-A	9.84	1.89	.91	2.01	.91					

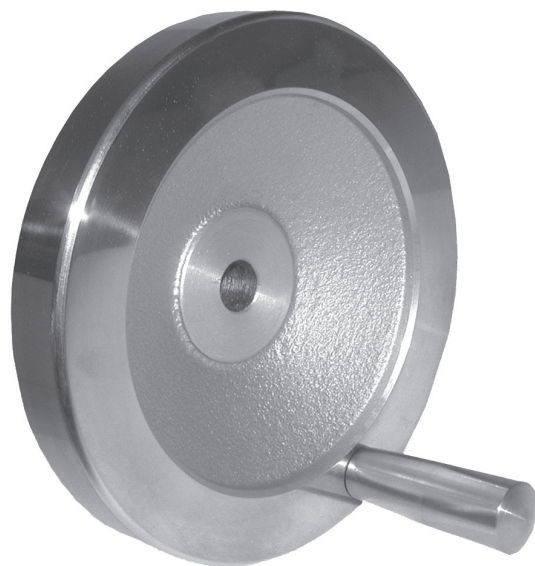

High-quality aluminum Hand Wheel, with contemporary design. Rim is machined and highly polished on all sides. Solid inner dish is shot-blasted to a satin finish. These Hand Wheels are bored to the standard shaft diameter for their size, and are tapped for a Solid or Revolving Handle (also available without tapped hole for handle). Rim is concentric and square to the bore. Order Solid or Revolving Handle separately. Matching square-design stainless steel handles are recommended.

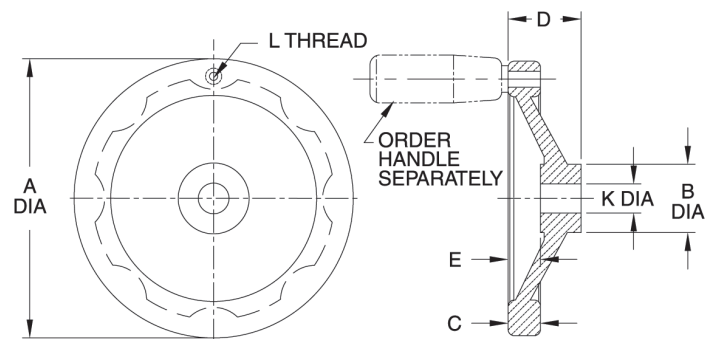

SOLID SQUARE DESIGN — ALUMINUM

PART NO. WITH TAPPED HOLE FOR HANDLE	A DIA	B DIA	C	D	E	K DIA	L	HANDLE		
								SIZE	SOLID	REVOLVING
CL-40-HWSS-A	3.94	1.10	.55	1.18	.51	.375	1/4-20	SIZE 2	SEE PAGE 138	SEE PAGES 139-141
CL-50-HWSS-A	4.92	1.22	.59	1.30	.59			SIZE 3		
CL-60-HWSS-A	6.30	1.42	.71	1.54	.75	.500	5/16-18	SIZE 4		
CL-80-HWSS-A	7.87	1.65	.81	1.77	.83					

HAND WHEELS

300-SERIES STAINLESS STEEL

3

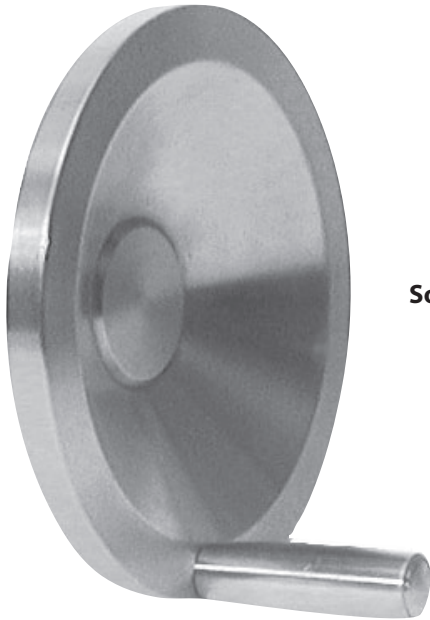

**Solid Square Design
Stainless Steel**

High-quality, stainless steel Hand Wheel. Contemporary square design, completely machined to a fine finish from solid 300-series stainless steel. This precision Hand Wheel is extremely strong, yet light weight. Stainless steel Hand Wheels are center drilled, and also tapped for a standard Solid or Revolving Handle. Order handle separately.

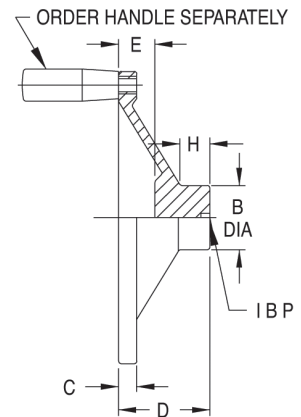
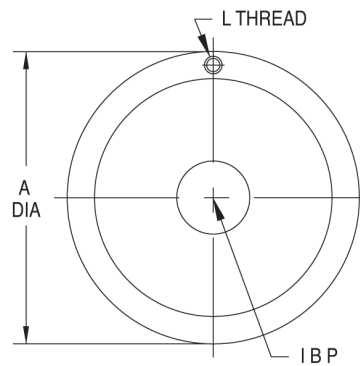
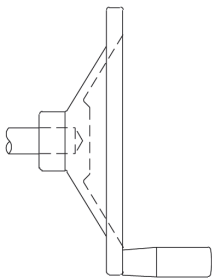

These Hand Wheels can be bored with a blind hole to hide the shaft, for an extremely attractive finished appearance.

ORDER HAND WHEEL AND SOLID/REVOLVING HANDLE SEPARATELY

PART NO. WITH TAPPED HOLE FOR HANDLE	A DIA	B DIA	C	D	E	H	L	MATCHING HANDLE		
								SIZE	SOLID	REVOLVING
CL-30-HWSS-S	3	.87	1/4	1.10	.43	3/8	1/4-20	SIZE 1	CL-100-SH-S	CL-100-RH-S
CL-40-HWSS-S	4	1.02	5/16	1.25	.54	7/16		SIZE 2	CL-200-SH-S	CL-200-RH-S
CL-60-HWSS-S	6	1.50	1/2	1.50	.63	1/2		SIZE 3	CL-300-SH-S	CL-300-RH-S
CL-80-HWSS-S	8	1.80	9/16	1.80	.85	5/8	5/16-18			

HAND WHEELS

BODY: BLACK FIBER-REINFORCED NYLON THERMOPLASTIC
HUB: MILD STEEL, ZINC PLATED CLEAR CHROMATE

3



**Angled-Spoke Square Design
Thermoplastic
with Revolving Handle**



**Angled-Spoke Square Design
Thermoplastic
with Foldable Revolving Handle**

High-quality, thermoplastic Hand Wheel with three spokes, with contemporary design. Molded-in steel hub, blank with a pilot hole. Available with either a Revolving Handle, a Foldable Revolving Handle, or a plain rim without a handle. Matte black fiber-reinforced nylon thermoplastic (textured surface for secure gripping, excellent impact resistance, operating temperatures to 230°F).

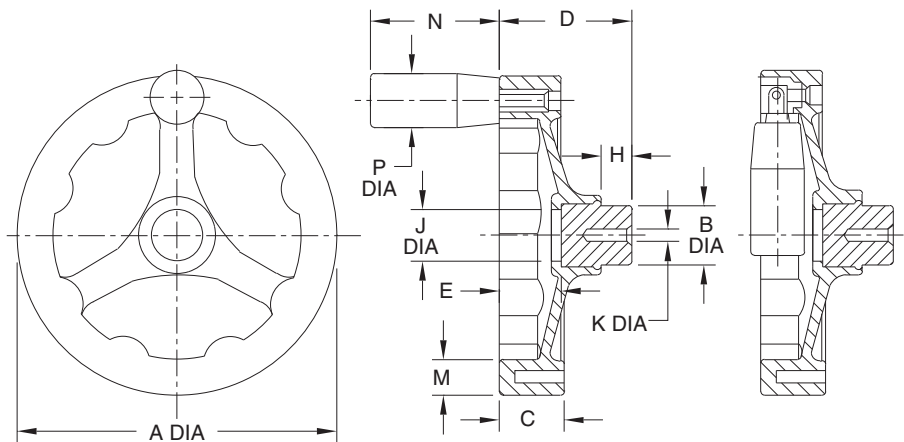

PART NO. WITH FOLDABLE REVOLVING HANDLE	A DIA	B DIA	C	D	E	H	J DIA	K DIA	M	N	P DIA
CL-52-HWAS-P	4.92	.94	.94	2.01	.91	.47	.79	.157	.67	1.97	.83
CL-62-HWAS-P	6.30	1.26	1.10	2.40	1.18	.59	1.18	.236	.79	2.76	.91

HAND WHEELS

BODY: MATTE BLACK FIBER-REINFORCED NYLON THERMOPLASTIC
 HUB: MILD STEEL, ZINC PLATED CLEAR CHROMATE

3



**Solid Square Design
 Thermoplastic
 with Revolving Handle**



**Solid Square Design
 Thermoplastic
 with Foldable Revolving Handle**

High-quality, thermoplastic Hand Wheel with two spokes, with contemporary design. Molded-in steel hub. These Hand Wheels are bored to the standard shaft diameter for their size. Available with either a Revolving Handle, a Foldable Revolving Handle, or a plain rim without a handle. Matte black high-impact thermoplastic (textured surface for secure gripping, excellent impact resistance, operating temperatures to 230°F).

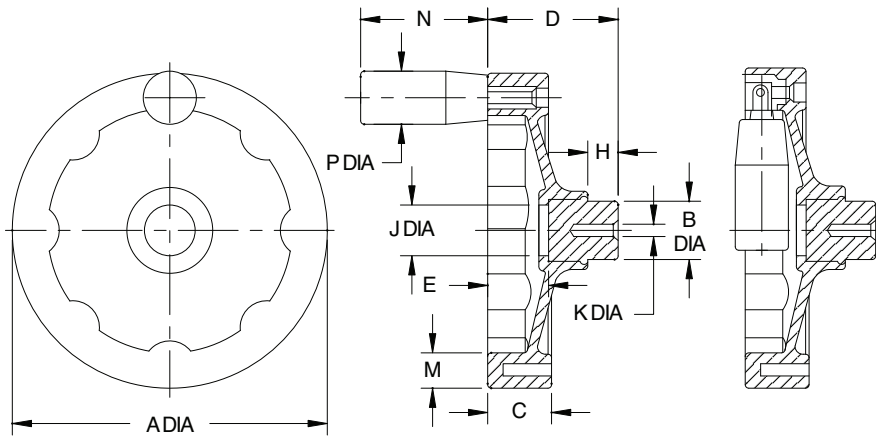

PART NO. WITH REVOLVING HANDLE	PART NO. WITH FOLDABLE REVOLVING HANDLE	A DIA	B DIA	C	D	E	H	J DIA	K DIA	M	N	P DIA
CL-41-HWSS-P	CL-42-HWSS-P	3.94	.94	79	1.81	.87	.47	.71	.157	.59	1.97	.83
CL-51-HWSS-P	CL-52-HWSS-P	4.92		.94	2.01	.91		.79	.236	.67		
CL-61-HWSS-P	CL-62-HWSS-P	6.30	1.26	1.10	2.40	1.18	.59	1.18	.236	.79	2.76	.91
CL-81-HWSS-P	CL-82-HWSS-P	7.87	1.57	1.26	2.91	1.34		1.38		.94		3.57

FLUTED HAND WHEELS

BODY: BLACK PHENOLIC PLASTIC
HUB: MILD STEEL, ZINC PLATED CLEAR CHROMATE

3



CL-4-FHW



CL-3-FHW

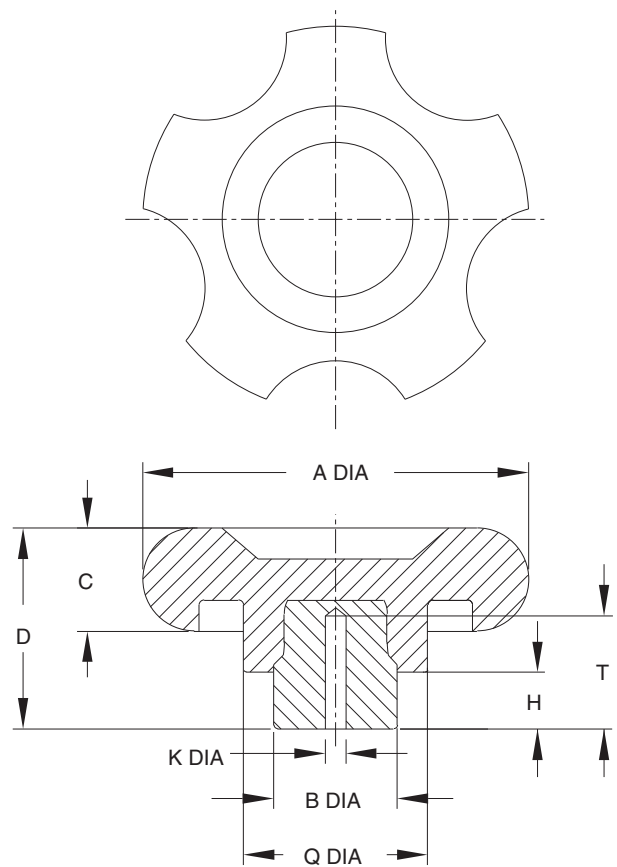

Small five-lobed phenolic hand wheels that are useful as control knobs or clamping knobs. Available in two diameters. Molded-in steel hub, blank with a pilot hole. Black phenolic plastic (glossy smooth finish, extremely hard, electrical insulator, operating temperatures to 300°F, resistant to oils and most common chemicals).

PART NO.	A DIA	B DIA	C	D	H	K DIA	Q DIA	T
CL-3-FHW	2.95	.94	.79	1.54	.43	.157	1.34	.87
CL-4-FHW	3.54	1.26		1.65	.47	.236	1.73	.98

SOLID HANDLES

STEEL: 1215, BLACK OXIDE FINISH. STAINLESS STEEL: 300 SERIES.

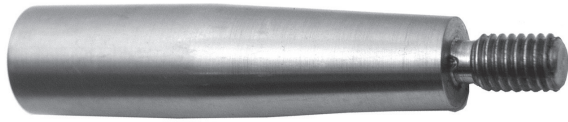

**Square Design
Threaded
Stainless Steel**

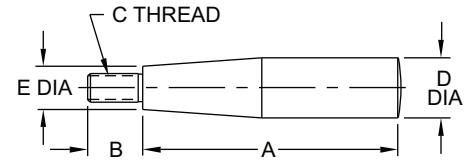

**Rounded Design
Threaded
Stainless Steel**

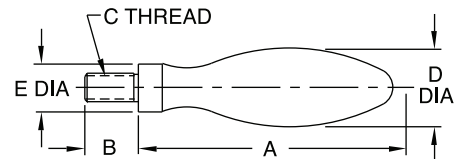

**Rounded Design
Press Fit
Steel, Black Oxide Finish**

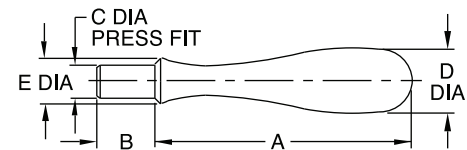

SQUARE DESIGN, THREADED — STAINLESS (INCH)

PART NO.	SIZE	A	B	C	D DIA	E DIA
CL-100-SH-S	1	1-1/2	9/32	1/4-20	1/2	13/32
CL-200-SH-S	2	2	7/16			
CL-300-SH-S	3	2-1/2	9/16	5/16-18	5/8	15/32
CL-400-SH-S	4	3-1/4	11/16	3/8-16	3/4	19/32

ROUNDED DESIGN, THREADED — STAINLESS (INCH)

CL-250-SH-S	2	2	1/2	1/4-20	5/8	.44
CL-350-SH-S	3	2-5/8	9/16	5/16-18	13/16	.53
CL-450-SH-S	4	3-3/16	11/16	3/8-16	1	.63
CL-550-SH-S	5	3-3/4	13/16	1/2-13	1-1/4	.75

ROUNDED DESIGN, PRESS FIT — STEEL (INCH)

CL-1-SH	2	2	9/16	3/8	11/16	5/8
CL-2-SH	4	3-1/4	3/4	7/16	1	11/16
CL-3-SH	5	3-7/8	1	1/2	1-3/16	7/8

Attractive fixed handles available in steel with a black oxide finish, or stainless steel with a polished finish. Available in square or rounded designs, each in several sizes. Choice of threaded type or press-fit type (do not use press-fit handles on aluminum hand wheels).

SQUARE DESIGN, THREADED — STAINLESS (METRIC)

PART NO.	HANDLE SIZE	A (mm)	B (mm)	C THREAD	THREAD PITCH (mm)	D DIA (mm)	E DIA (mm)
CLM-100-SH-S	SIZE 1	38	7	M6	1	13	10
CLM-200-SH-S	SIZE 2	51	11	M6	1	13	10
CLM-300-SH-S	SIZE 3	64	14	M8	1.25	16	12
CLM-400-SH-S	SIZE 4	83	17	M10	1.5	19	15

ROUNDED DESIGN, THREADED — STAINLESS (METRIC)

CLM-250-SH-S	SIZE 2	51	13	M6	1	16	10
CLM-350-SH-S	SIZE 3	67	14	M8	1.25	21	13
CLM-450-SH-S	SIZE 4	81	17	M10	1.5	25	16
CLM-550-SH-S	SIZE 5	95	21	M12	1.75	32	19

FINGER PINS

1215 STEEL, BLACK OXIDE FINISH

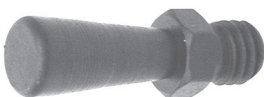

Miniature, fixed finger handle in steel, with a black oxide finish.

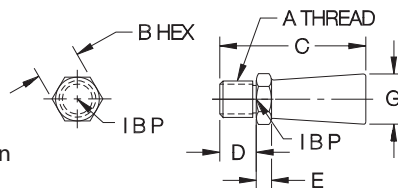

INCH

PART NO.	A	B	C	D	E	G DIA
CL-0-FP	#10-32	1/4	3/4	1/4	7/64	1/4
CL-1-FP	#10-24					
CL-2-FP	5/16-18	3/8	1-1/4	5/16	5/32	3/8

METRIC

CLM-5-FP	M5	6mm	.75	M6	.12	.24
CLM-8-FP	M8	10mm	1.26	M8	.16	.39

REVOLVING HANDLES

STEEL: 1215, BLACK OXIDE FINISH. STAINLESS STEEL: 300 SERIES

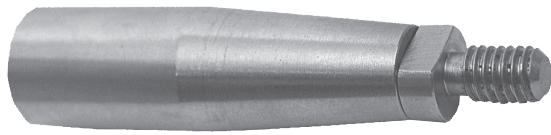

**Square Design
Threaded
Stainless Steel**

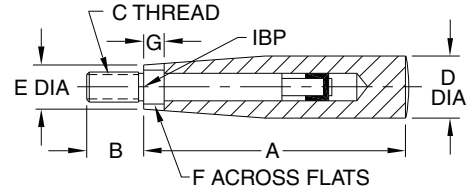

**Rounded Design
Threaded
Stainless Steel**

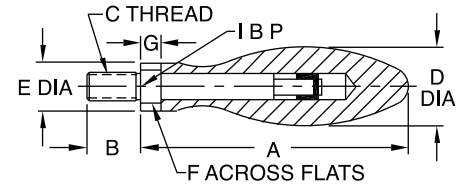

**Rounded Design
Shoulder Screw
Steel, Black Oxide Finish**

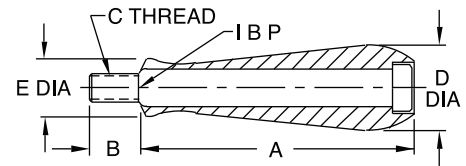

**Rounded Design
Press Fit
Steel, Black Oxide Finish**

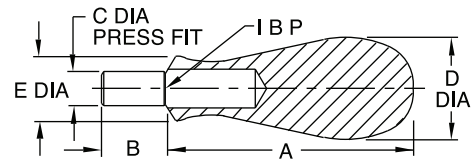

Revolving Handles have an internal bearing that allows the handle to remain fixed in your hand, for firm gripping, while turning a hand wheel or crank. These attractive handles are available in steel with a black oxide finish, or stainless steel with a polished finish. Available in square or rounded designs, each in several sizes. Choice of threaded type or press-fit type (do not use press-fit handles on aluminum hand wheels).

SQUARE DESIGN, THREADED — STAINLESS (INCH)

PART NO.	SIZE	A	B	C	D DIA	E DIA	F	G
CL-100-RH-S	1	1-1/2	9/32	1/4-20	1/2	13/32	5/16	.25
CL-200-RH-S	2	2	1/2					.28
CL-300-RH-S	3	2-1/2	9/16	5/16-18	5/8	15/32	3/8	.32
CL-400-RH-S	4	3-1/4	5/8	3/8-16	3/4	19/32	7/16	.39

ROUNDED DESIGN, THREADED — STAINLESS (INCH)

CL-250-RH-S	2	2-1/4	1/2	1/4-20	5/8	.44	5/16	.25
CL-350-RH-S	3	2-13/16	9/16	5/16-18	13/16	.53	3/8	.28
CL-450-RH-S	4	3-3/8	5/8	3/8-16	1	.63	7/16	.32
CL-550-RH-S	5	4	3/4	1/2-13	1-1/4	.75	5/8	.39

ROUNDED DESIGN, SHOULDER SCREW — STEEL (INCH)

CL-1-RH	2	2	7/16	1/4-20	11/16	5/8	—	—
CL-2-RH	4	3-3/8	11/16	3/8-16	1	11/16	—	—
CL-3-RH	5	3-7/8	3/4	1/2-13	1-3/16	7/8	—	—

ROUNDED DESIGN, PRESS FIT — STEEL (INCH)

CL-4-RH	2	2-3/8	19/32	5/16	11/16	5/8	—	—
---------	---	-------	-------	------	-------	-----	---	---

SQUARE DESIGN, THREADED — STAINLESS (METRIC)

PART NO.	HANDLE SIZE	A (mm)	B (mm)	C THREAD	THREAD PITCH (mm)	D DIA (mm)	E DIA (mm)	F (mm)	G (mm)
CLM-100-RH-S	SIZE 1	38	7	M6	1	16	12	8	5
CLM-200-RH-S	SIZE 2	51	13	M6	1	16	12	8	6.5
CLM-300-RH-S	SIZE 3	64	14	M8	1.25	19	14	9.5	7
CLM-400-RH-S	SIZE 4	83	16	M10	1.5	22	16	11	8

ROUNDED DESIGN, THREADED — STAINLESS (INCH)

PART NO.	SIZE	A	B	C	D DIA	E DIA	F	G
CLM-250-RH-S	2	2-1/4	1/2	M6	5/8	.44	5/16	.25
CLM-350-RH-S	3	2-13/16	9/16	M8	13/16	.53	3/8	.28
CLM-450-RH-S	4	3-3/8	5/8	M10	1	.63	7/16	.32
CLM-550-RH-S	5	4	3/4	M12	1-1/4	.75	5/8	.39

ROUNDED DESIGN, SHOULDER SCREW — STEEL (INCH)

CLM-1-RH	2	2	7/16	M6	13/16	3/4	—	—
CLM-2-RH	4	3-1/4	9/16	M10	1-1/4	15/16	—	—
CLM-3-RH	5	3-7/8	3/4	M12	1-1/2	1-1/8	—	—

REVOLVING HANDLES

BODY: BLACK PHENOLIC PLASTIC OR NYLON THERMOPLASTIC
 THREADED SPINDLE: MILD STEEL, ZINC PLATED CLEAR CHROMATE

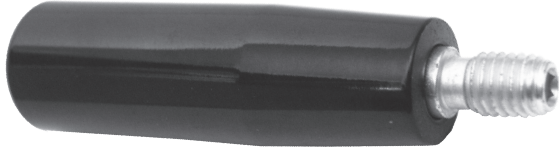

**Phenolic
with Steel Body**



**Thermoplastic
with Steel Body**

Modern square-design handle with a threaded steel spindle. Revolving Handles have an internal bearing that allows the handle to remain fixed in your hand, for firm gripping while turning a Hand Wheel or crank. Threaded spindle has a hex socket for easy installation. Available in two handle materials: Black phenolic plastic (glossy smooth finish, extremely hard, electrical insulator, operating temperatures to 300°F, resistant to oils and most common chemicals) or matte black nylon thermoplastic (textured surface for secure gripping, excellent impact resistance, operating temperatures to 230°F).

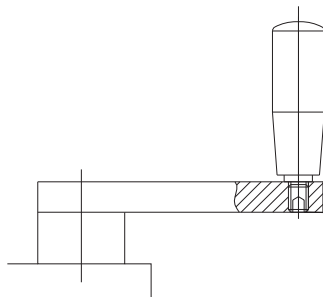

Revolving Handles can be used to make custom crank handles.

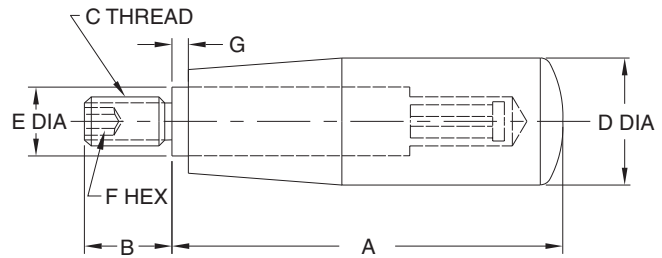

INCH

PART NO. PHENOLIC	PART NO. THERMOPLASTIC	SIZE	A	B	C	D DIA	E DIA	F	G
CL-100-RH-F	CL-100-RH-P	1	1.67	.47	1/4-20	.71	.39	3mm	.10
CL-200-RH-F	CL-200-RH-P	2	2.07	.51		.83			
CL-300-RH-F	CL-300-RH-P	3	2.66	.55	5/16-18	.91	4mm		
CL-400-RH-F	CL-400-RH-P	4	3.25	.63	3/8-16	1.02	5mm		
CL-500-RH-F	—	5	4.12	.79	1/2-13	1.22	6mm		

METRIC

PART NO. PHENOLIC	PART NO. THERMOPLASTIC	HANDLE SIZE	A (mm)	B (mm)	C THREAD	THREAD PITCH (mm)	D DIA (mm)	E DIA (mm)	F (mm)	G (mm)
CLM-100-RH-F	CLM-100-RH-P	SIZE 1	42.5	12	M6	1	18	10	3	2.5
CLM-200-RH-F	CLM-200-RH-P	SIZE 2	52.5	13	M6	1	21	10	3	2.5
CLM-201-RH-F	—	—	52.5	13	M8	1.25	21	10	4	2.5
CLM-300-RH-F	CLM-300-RH-P	SIZE 3	67.5	14	M8	1.25	23	13	4	2.5
CLM-400-RH-F	CLM-400-RH-P	SIZE 4	82.5	15	M10	1.5	26	13	5	2.5
CLM-500-RH-F	—	SIZE 5	104.5	20	M12	1.75	31	14	6	2.5

FOLDABLE REVOLVING HANDLES

BODY: 300-SERIES STAINLESS STEEL. HANDLE: BLACK THERMOPLASTIC



**Thermoplastic with
Stainless Steel Body**

Unique revolving handle that can fold away when not in use. Handle is positively locked in extended position. Like other revolving handles, this foldable handle has an internal bearing that allows it to remain fixed in your hand, for firm gripping, while turning a hand wheel or crank. To allow folding, the handle must first be pulled outward, against a spring force, then moved 90°. Once folded, the handle is held in that position also by spring force.

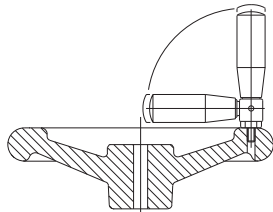

To install handle in tapped hole, screw in as far as possible, then back off until the handle is at the desired orientation. Tighten Jam Nut to secure at that orientation.

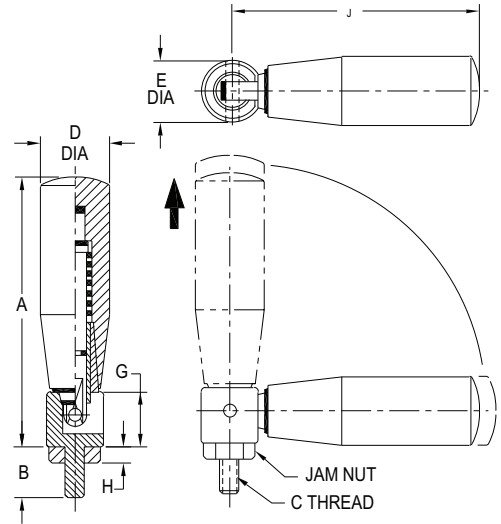

INCH

PART NO.	SIZE	A	B	C	D DIA	E DIA	G	H	J
CL-200-FRH-S	2	2-1/2	5/8	1/4-20	7/8	.63	1/2	11/64	2-3/8
CL-300-FRH-S	3	3-1/4	3/4	5/16-18	15/16	.78	5/8	13/64	3-1/8
CL-400-FRH-S	4	3-3/4	7/8	3/8-16	1	.78	5/8	15/64	3-5/8

REVOLVING BALL HANDLES

BALL KNOB: BLACK PHENOLIC PLASTIC
THREADED SPINDLE: MILD STEEL, BLACK OXIDE FINISH OR ZINC PLATED CLEAR CHROMATE



**Phenolic
with Steel Body**

Revolving handle with a ball knob made of phenolic plastic and a threaded steel spindle. This version is especially useful for hand wheels or cranks mounted horizontally with the handle used as a hand rest. Revolving Ball Handles have an internal bearing that allows the handle to remain fixed in your hand, for firm gripping. Threaded spindle has a hex socket for easy installation.

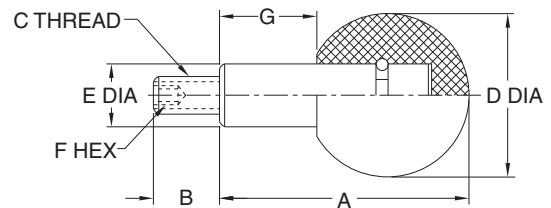

INCH

PART NO.	SIZE	A	B	C	D DIA	E DIA	F	G
CL-200-RBH	2	1.48	.43	1/4-20	.98	.39	3mm	.59
CL-300-RBH	3	1.89	.51	5/16-18	1.26	.51	4mm	.75
CL-400-RBH	4	2.40	.55	3/8-16	1.57	.63	5mm	.94
CL-500-RBH	5	3.07	.83	1/2-13	1.97	.79	6mm	1.22

METRIC

PART NO.	HANDLE SIZE	A (mm)	B (mm)	C THREAD	THREAD PITCH (mm)	D DIA (mm)	E DIA (mm)	F (mm)	G (mm)
CLM-200-RBH	SIZE 2	37.5	11	M6	1	25	10	3	15
CLM-300-RBH	SIZE 3	48	13	M8	1.25	32	13	4	19
CLM-500-RBH	SIZE 5	78	21	M12	1.75	50	20	6	31

LEVER HANDLES

300-SERIES STAINLESS STEEL

3



**Single
Lever Handle**



**Triple
Lever Handle**

Fast, efficient levers that provide high torque. These attractive Lever Handles are made of 300-series stainless steel, polished to a beautiful finish. Hubs are available in single-handle or triple-handle versions, each in two sizes. Lever Handles can be totally customized by choosing Lever Bar length and Knob type.



Single Hub

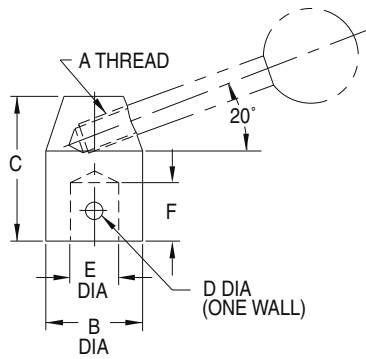

Triple Hub

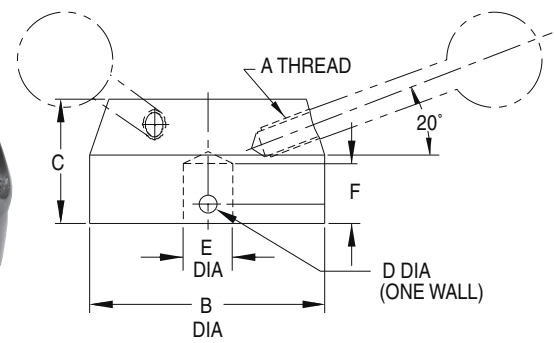

SINGLE LEVER HANDLE — ORDER HUB, LEVER BAR, AND KNOB SEPARATELY (INCH)

PART NO. HUB ONLY	A	B DIA	C	D DIA	E	F	PART NO. LEVER BAR	PART NO. KNOB
CL-116-LHH-S	5/16-18	1	1-1/2	1/8	3/8 DIA REAMED	5/8	INFO+: SEE PAGE 143	INFO+: SEE PAGES 152-159
CL-1160-LHH-S				—	3/8-16 TAPPED	9/16		
CL-128-LHH-S	3/8-16	1-1/4	1-7/8	5/32	1/2 DIA REAMED	3/4		
CL-1280-LHH-S				—	1/2-13 TAPPED	11/16		

TRIPLE LEVER HANDLE — ORDER HUB, LEVER BARS, AND KNOBS SEPARATELY (INCH)

CL-316-LHH-S	5/16-18	2	1	3/16	3/8 DIA REAMED	3/4	INFO+: SEE PAGE 143	INFO+: SEE PAGES 152-159
CL-328-LHH-S	3/8-16	2-3/8	1-3/16	3/16	1/2 DIA REAMED	7/8		

LEVER BARS

300-SERIES STAINLESS STEEL



Versatile Lever Bars available in three diameters, each in several lengths. 300-series stainless steel polished to a beautiful finish. **INFO+**: Can be used with the hubs on page 142 to make lever handles. Wrench flat allows firm tightening.

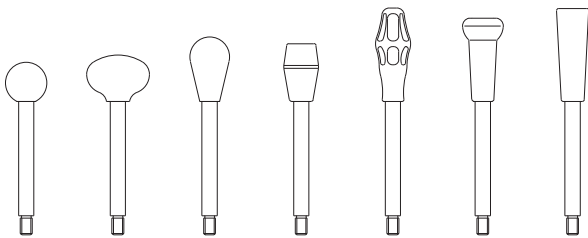
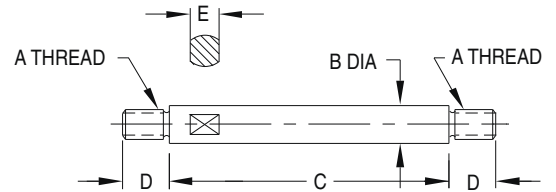

INCH

PART NO.	A	B DIA	C	D	E
CL-515-LVB-S	5/16-18	.39	1.5	7/16	5/16
CL-522-LVB-S			2.2		
CL-530-LVB-S			3.0		
CL-540-LVB-S			4.0		
CL-555-LVB-S			5.5		
CL-620-LVB-S	3/8-16	.47	2.0	1/2	3/8
CL-627-LVB-S			2.7		
CL-637-LVB-S			3.7		
CL-647-LVB-S			4.7		
CL-660-LVB-S			6.0		
CL-837-LVB-S	1/2-13	.55	3.7	5/8	7/16
CL-847-LVB-S			4.7		
CL-857-LVB-S			5.7		
CL-867-LVB-S			6.7		

Discover Solutions at CarrLane.com

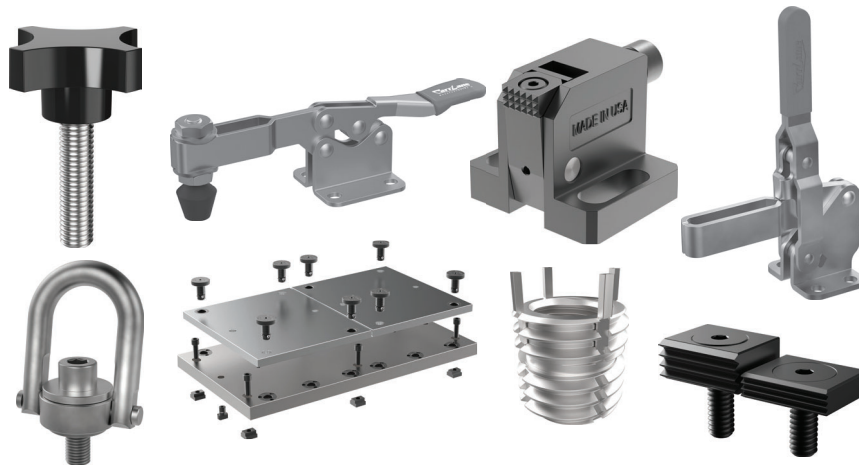

CRANK HANDLES

NODULAR IRON PER ASTM A536 CLASS 65-45-12, ZINC PLATED CLEAR CHROMATE



Rugged crank handle with a comfortable grip. Choice of three sizes that fit all common square drives.

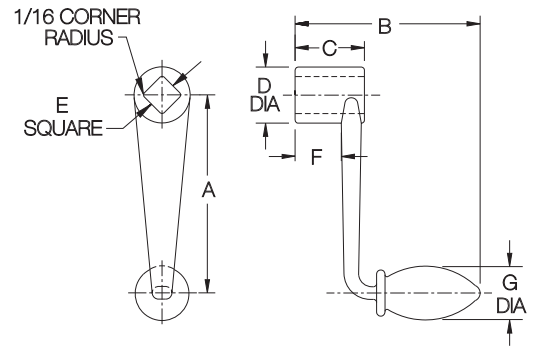

PART NO.	SQUARE DRIVE SIZE	A	B	C	D DIA	E	F	G DIA
CL-0-H	3/8 or 10mm	2-1/4	3	1	7/8	13/32	5/8	5/8
CL-1-H	1/2 or 12mm	3-3/4	4-3/16	1-5/16	1-1/16	17/32	7/8	7/8
CL-2-H	5/8 or 16mm	5-1/4	5-1/2	2-1/2	1-3/8	21/32	1-3/4	1

SPEED BALL HANDLES

NODULAR IRON PER ASTM-A536 CLASS 65-45-12, ZINC PLATED CLEAR CHROMATE



Double Arm

Speed handles that are weighted for quick turning. Long arm extensions provide excellent leverage for hand tightening.

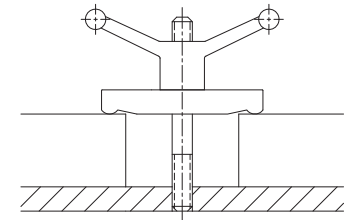

DOUBLE ARM (INCH & METRIC)

PART NO.	A	B	C DIA	D	E
CL-4-SBH	4-7/8	1-5/8	1-1/8	2-1/4	BLANK
CL-44-SBH					1/2-13
CLM-44-SBH					M12
CL-6-SBH	6	1-5/8	1-3/8	2-3/8	BLANK
CL-64-SBH					5/8-11
CLM-64-SBH					M16
CL-8-SBH	8	1-13/16	1-3/4	2-7/8	BLANK
CL-84-SBH					3/4-10
CLM-84-SBH					M20

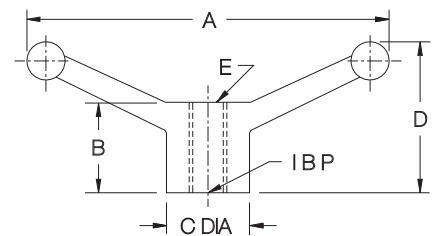

Single Arm

SINGLE ARM (INCH & METRIC)

PART NO.	A	B	C DIA	D	E
CL-5-SBH	3	1-5/8	1-3/8	2-3/8	BLANK
CL-55-SBH					1/2-13
CL-59-SBH					5/8-11
CLM-55-SBH					M12
CLM-59-SBH					M16
CL-7-SBH	4-3/8	2	1-5/8	3-1/2	BLANK
CL-75-SBH					3/4-10
CLM-75-SBH					M20

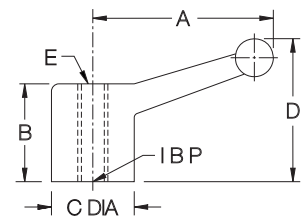

BALANCED CRANK HANDLES

300-SERIES STAINLESS STEEL

3



**Rounded Handle
(Solid or Revolving)
Stainless Steel**



**Square Handle
(Solid or Revolving)
Stainless Steel**

High-quality, stainless steel crank handle with a beautiful polished finish. Handle is balanced for smooth operation, and so that no rotation occurs due to handle weight. The reamed center hole is cross-drilled in one wall for easy installation by pinning. Order body and handle separately, with a choice of four handle types:

INFO+:

- Rounded-design Solid Handle (page 138)
- Rounded-design Revolving Handle (page 139)
- Square-design Solid Handle (page 138)
- Square-design Revolving Handle (page 139)

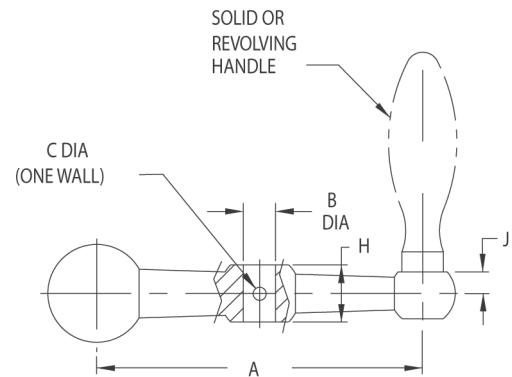
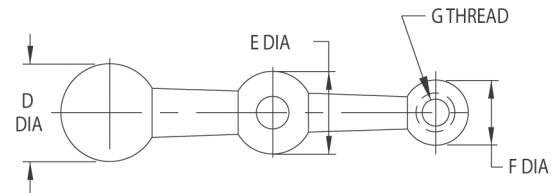

ORDER BODY AND SOLID/REVOLVING HANDLE SEPARATELY

PART NO. BODY ONLY	A	B DIA	C DIA	D DIA	E DIA	F DIA	G	H	J	PART NO. — SOLID OR REVOLVING HANDLE			
										ROUNDED SOLID	ROUNDED REVOLVING	SQUARE SOLID	SQUARE REVOLVING
CL-30-CHB-S	3-1/8	3/8	5/32	1-1/4	1	3/4	5-16/18	11/16	5/16	CL-350-SH-S	CL-350-RH-S	CL-300-SH-S	CL-300-RH-S
CL-40-CHB-S	4									CL-450-SH-S	CL-450-RH-S	CL-400-SH-S	CL-400-RH-S
CL-50-CHB-S	5	1/2	3/16	1-1/2	1-14	1	3/8-16	7/8	3/8	CL-450-SH-S	CL-450-RH-S	CL-400-SH-S	CL-400-RH-S
CL-51-CHB-S		5/8*								CL-450-SH-S	CL-450-RH-S	CL-400-SH-S	CL-400-RH-S

*1/8" Square keyway on this size only.

ADJUSTABLE HANDLES

HANDLE: ZINC DIE CASTING; ENAMEL PAINT
 BODY: 1215 STEEL, BLACK OXIDE FINISH. SPRING: MUSIC WIRE

Steel Body
Zinc Die Cast Handle (Moss Green)

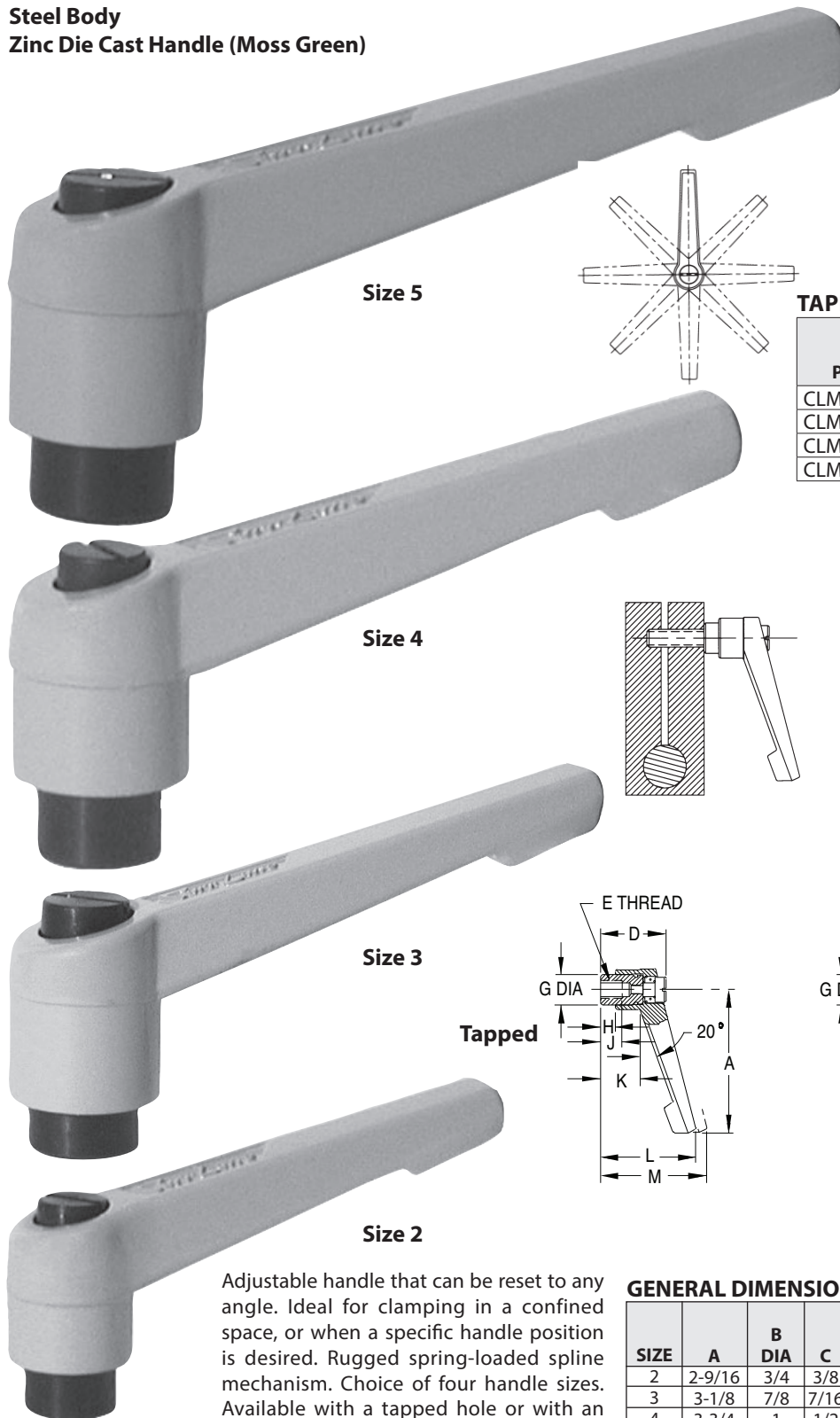

Size 5

Size 4

Size 3

Size 2

Adjustable handle that can be reset to any angle. Ideal for clamping in a confined space, or when a specific handle position is desired. Rugged spring-loaded spline mechanism. Choice of four handle sizes. Available with a tapped hole or with an integral stud.

TAPPED (INCH)

PART NO.	SIZE	E	J
CL-4-AH-2	2	1/4-20	1/2
CL-5-AH-2		5/16-18	
CL-5-AH-3	3	5/16-18	9/16
CL-6-AH-3		3/8-16	
CL-6-AH-4	4	3/8-16	5/8
CL-8-AH-4		1/2-13	
CL-8-AH-5	5	1/2-13	7/8
CL-10-AH-5		5/8-11	

TAPPED (METRIC)

PART NO.	SIZE	E THREAD	THREAD PITCH (mm)	J (mm)
CLM-8-AH-2	2	M8	1.25	12
CLM-10-AH-3	3	M10	1.5	14
CLM-12-AH-4	4	M12	1.75	16
CLM-16-AH-5	5	M16	2	22

STUD TYPE (INCH)

PART NO.	SIZE	E	F
CL-510-AH-2	2	5/16-18	1
CL-515-AH-2			1-1/2
CL-520-AH-2			2
CL-610-AH-3	3	3/8-16	1
CL-615-AH-3			1-1/2
CL-620-AH-3			2
CL-810-AH-4	4	1/2-13	1
CL-815-AH-4			1-1/2
CL-820-AH-4			2
CL-830-AH-4			3
CL-1015-AH-5	5	5/8-11	1-1/2
CL-1020-AH-5			2
CL-1030-AH-5			3

GENERAL DIMENSIONS

SIZE	A	B DIA	C	D	G DIA	H	K	L	M
2	2-9/16	3/4	3/8	1-1/8	17/32	1/4	11/16	1-11/16	1-7/8
3	3-1/8	7/8	7/16	1-1/2	5/8	13/32	15/16	2-3/16	2-5/16
4	3-3/4	1	1/2	1-11/16	3/4	13/32	1-1/16	2-1/2	2-11/16
5	4-5/16	1-1/4	5/8	2	15/16	15/32	1-5/16	2-15/16	3-1/8

ADJUSTABLE HANDLES

HANDLE: FIBER-REINFORCED THERMOPLASTIC WITH STAINLESS STEEL INSERT
BODY, SCREW, AND SPRING: STEEL, BLACK OXIDE FINISH

Steel Body
Plastic Handle (Black)

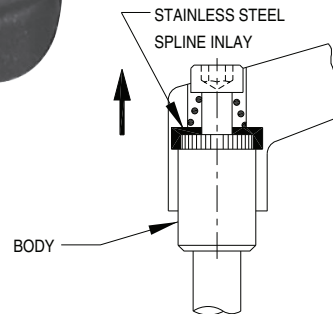
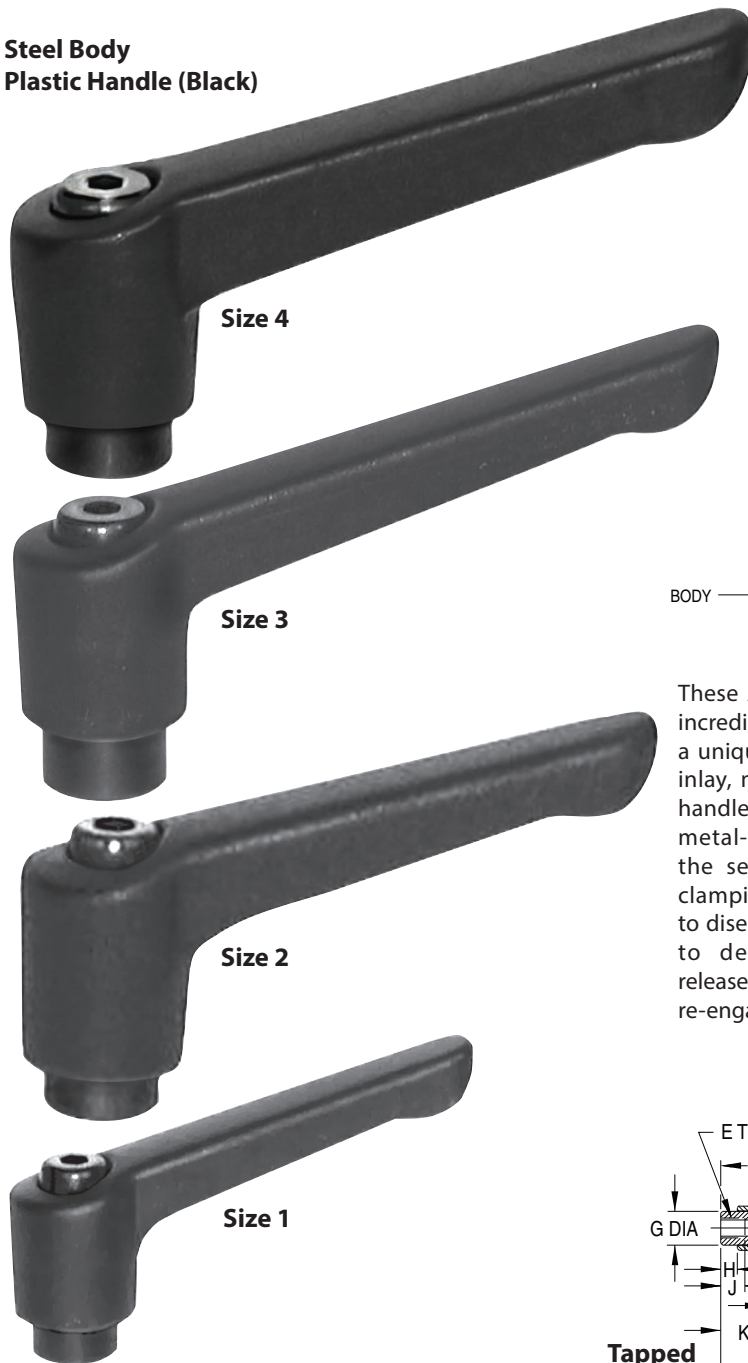

These Adjustable Handles are incredibly strong! They feature a unique stainless steel spline inlay, molded into the plastic handle. This provides positive metal-to-metal mating with the serrated body, for high clamping torque. Lift handle to disengage serrations, rotate to desired position, then release handle to automatically re-engage spline.

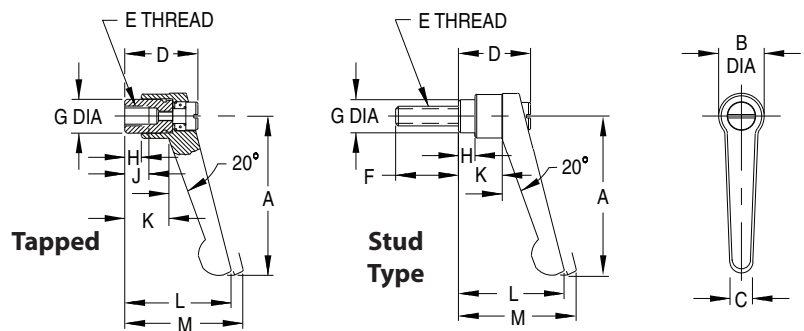

TAPPED (INCH)

PART NO. STEEL BLACK	SIZE	E	J
CL-3-AHP-1	1	#10-32	.31
CL-4-AHP-1		1/4-20	
CL-4-AHP-2	2	1/4-20	.39
CL-5-AHP-2		5/16-18	
CL-5-AHP-3	3	5/16-18	.55
CL-6-AHP-3		3/8-16	
CL-6-AHP-4	4	3/8-16	.67
CL-8-AHP-4		1/2-13	

TAPPED (METRIC)

CLM-6-AHP-1	1	M6	.31
CLM-8-AHP-2	2	M8	.39
CLM-10-AHP-3	3	M10	.55
CLM-12-AHP-4	4	M12	.67

STUD TYPE (INCH)

PART NO. STEEL BLACK	SIZE	E	F
CL-408-AHP-1	1	1/4-20	.78
CL-416-AHP-1		1.57	
CL-508-AHP-2	2	5/16-18	.78
CL-516-AHP-2		1.57	
CL-525-AHP-2	3	3/8-16	2.48
CL-610-AHP-3		.98	
CL-616-AHP-3	4	1/2-13	1.57
CL-625-AHP-3		2.48	
CL-816-AHP-4	4	1/2-13	1.57
CL-825-AHP-4		2.48	

STUD TYPE (METRIC)

CLM-620-AHP-1	1	M6	.20
CLM-640-AHP-1		.40	
CLM-820-AHP-2	2	M8	.20
CLM-840-AHP-2		.40	
CLM-1030-AHP-3	3	M10	.32
CLM-1050-AHP-3		.50	

Adjustable handle that can be reset to any angle. Ideal for clamping in a confined space, or when a specific handle position is desired. Available in steel (with a black plastic handle) or stainless steel (with a metallic-gray plastic handle, **INFO+** see page 148). Rugged spring-loaded spline mechanism. Choice of four handle sizes. Available with a tapped hole or with an integral stud.



GENERAL DIMENSIONS

SIZE	A	B DIA	C	D	G DIA	H	K	L	M
1	1-3/4	19/32	5/16	31/32	3/8	5/32	7/16	1-3/8	1-1/2
2	2-1/2	3/4	13/32	1-7/32	17/32	1/4	13/16	1-25/32	1-15/16
3	3-1/16	7/8	17/32	1-7/16	5/8	5/16	7/8	2-5/32	2-5/16
4	3-5/8	1	9/16	1-11/16	3/4	7/16	1-3/16	2-9/16	2-23/32

ADJUSTABLE HANDLES

HANDLE: FIBER-REINFORCED THERMOPLASTIC WITH STAINLESS STEEL INSERT
 BODY, SCREW, AND SPRING: 300-SERIES STAINLESS STEEL

Stainless Steel Body
Plastic Handle (Metallic Gray)

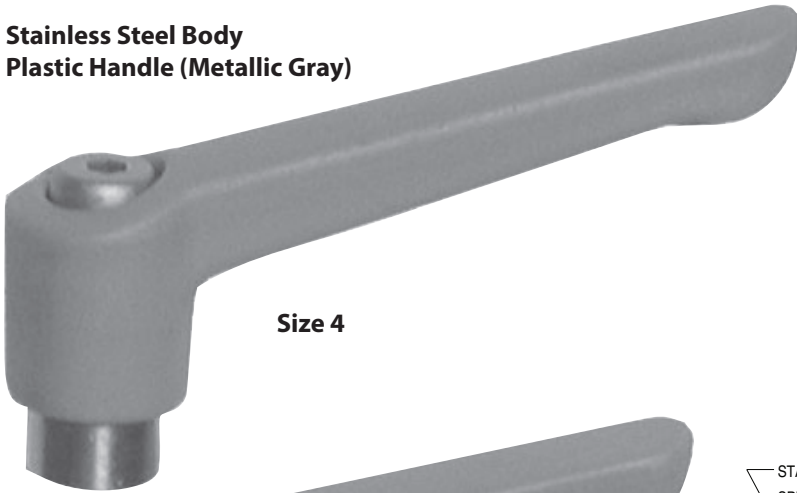

Size 4

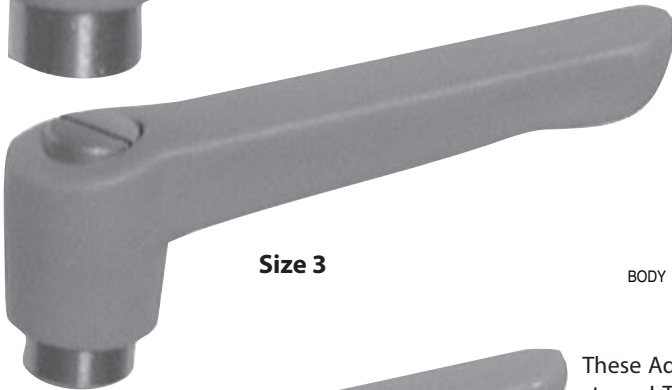

Size 3

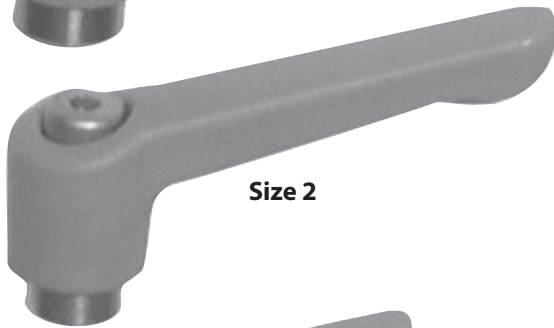

Size 2

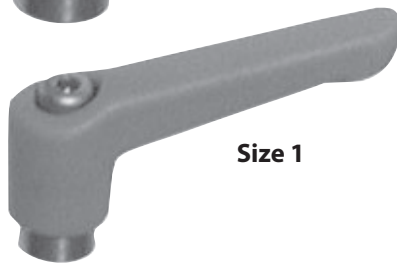

Size 1

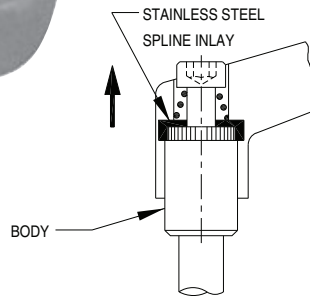

These Adjustable Handles are incredibly strong! They feature a unique stainless steel spline inlay, molded into the plastic handle. This provides positive metal-to-metal mating with the serrated body, for high clamping torque. Lift handle to disengage serrations, rotate to desired position, then release handle to automatically re-engage spline.

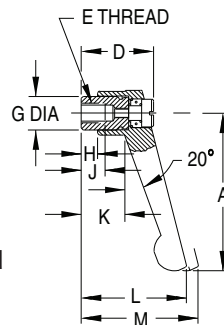

Tapped

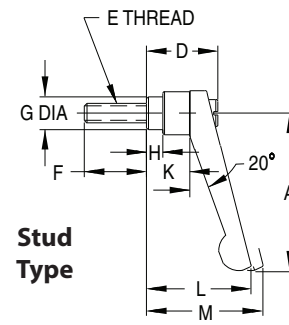

Stud Type

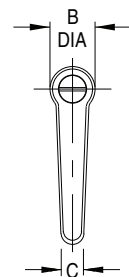

Adjustable handle that can be reset to any angle. Ideal for clamping in a confined space, or when a specific handle position is desired. Available in stainless steel (with a metallic-gray plastic handle), or steel (with a black plastic handle, **INFO+**: see page 147). Rugged spring-loaded spline mechanism. Choice of four handle sizes. Available with a tapped hole or with an integral stud.

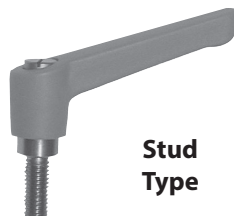

Stud Type

TAPPED (INCH)

PART NO. STAINLESS METALLIC GRAY	SIZE	E	J
CL-4-AHP-1-S	1	1/4-20	.31
CL-4-AHP-2-S	2	1/4-20	.39
CL-5-AHP-2-S		5/16-18	
CL-6-AHP-3-S	3	3/8-16	.55
CL-6-AHP-4-S	4	3/8-16	.67

STUD TYPE (INCH)

PART NO. STAINLESS METALLIC GRAY	SIZE	E	F
CL-408-AHP-1-S	1	1/4-20	.78
CL-416-AHP-1-S			1.57
CL-625-AHP-3-S	3	3/8-16	2.48
CL-813-AHP-4-S	4	1/2-13	1.26
CL-825-AHP-4-S			2.48

GENERAL DIMENSIONS

SIZE	A	B DIA	C	D	G DIA	H	K	L	M
1	1-3/4	19/32	5/16	31/32	3/8	5/32	7/16	1-3/8	1-1/2
2	2-1/2	3/4	13/32	1-7/32	17/32	1/4	13/16	1-25/32	1-15/16
3	3-1/16	7/8	17/32	1-7/16	5/8	5/16	7/8	2-5/32	2-5/16
4	3-5/8	1	9/16	1-11/16	3/4	7/16	1-3/16	2-9/16	2-23/32

ADJUSTABLE LEVER HANDLES

LEVER ARM, HUB, INSERT, AND SPRING: MILD STEEL, BLACK OXIDE FINISH
BALL KNOB: BLACK PHENOLIC PLASTIC

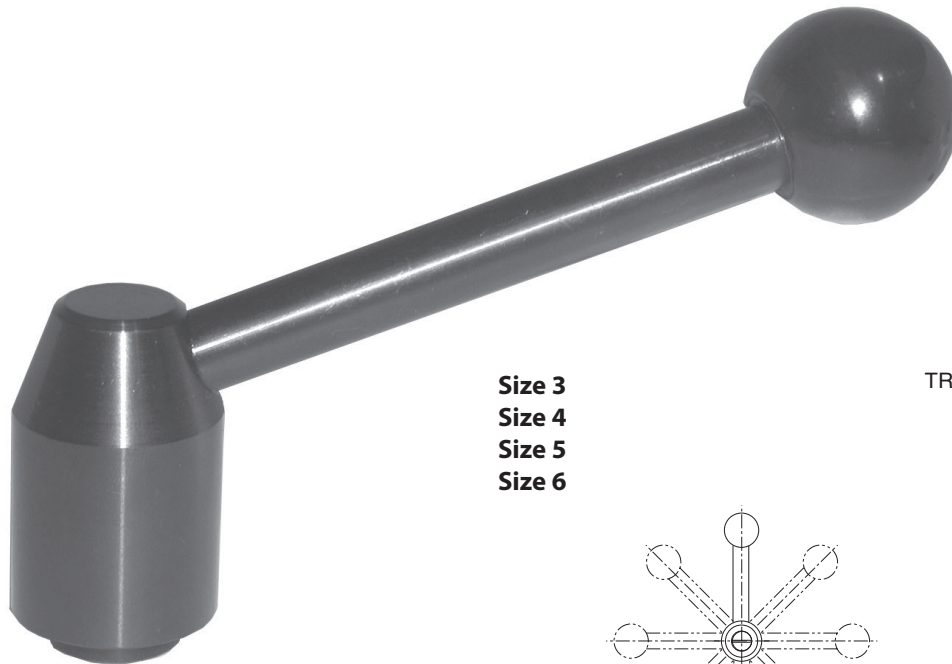

Size 3
Size 4
Size 5
Size 6

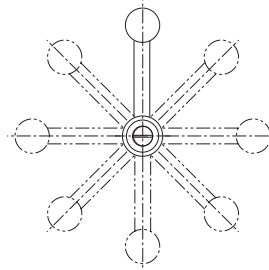

Steel

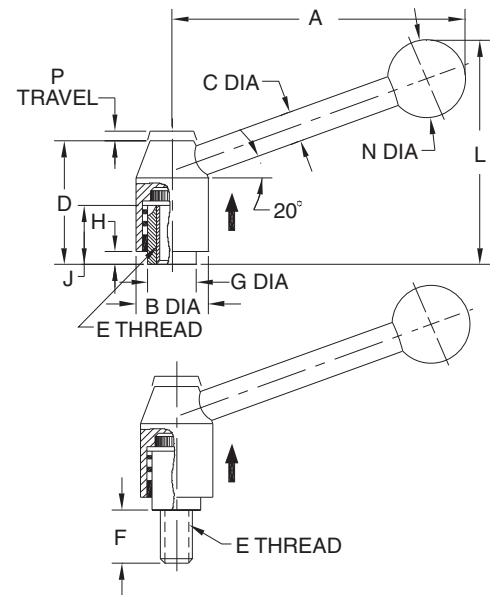

Heavy-duty adjustable handle that can be reset to any angle. Ideal for clamping in a confined space, or when a specific handle position is desired. Rugged spring-loaded spline mechanism. Lift handle to disengage serrations, rotate to desired position, then release handle to automatically re-engage spline. Available with a tapped hole or an integral stud.

STEEL — TAPPED (INCH)

PART NO.	SIZE	A	B DIA	C DIA	D	E	F	G	H	J	L	N DIA	P
CL-6-AHL-3	3	3.94	.94	.94	.94	.94	.94	.94	.10	.55	2.95	.98	.18
CL-8-AHL-4	4	4.53	1.10	1.10	1.10	1.10	1.10	1.10	.18	.67	3.54	1.18	
CL-12-AHL-6	6	5.71	1.57	1.57	1.57	1.57	1.57	1.57	.24	1.42	4.33	1.38	

STEEL — STUD TYPE (INCH)

CL-613-AHL-3	3	3.94	.94	.39	1.57	3/8-16	1.26	.63	.10	—	2.95	.98	.18
CL-625-AHL-3							2.48						
CL-813-AHL-4	4	4.53	1.10	.47	1.91	1/2-13	1.26	.75	.18	—	3.54	1.18	
CL-825-AHL-4							2.48						
CL-1025-AHL-5	5	5.12	1.30	.47	2.17	5/8-11	.91	.24	—	3.94	1.26	.22	

ADJUSTABLE LEVER HANDLES

LEVER ARM, HUB, INSERT, AND SPRING: STAINLESS STEEL
BALL KNOB: PHENOLIC PLASTIC

3

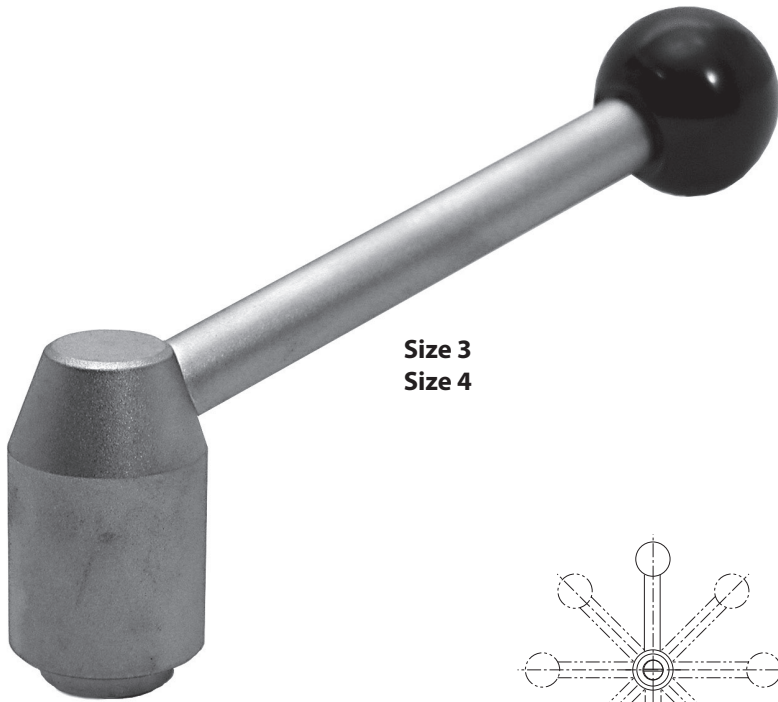

Stainless Steel

Size 3
Size 4

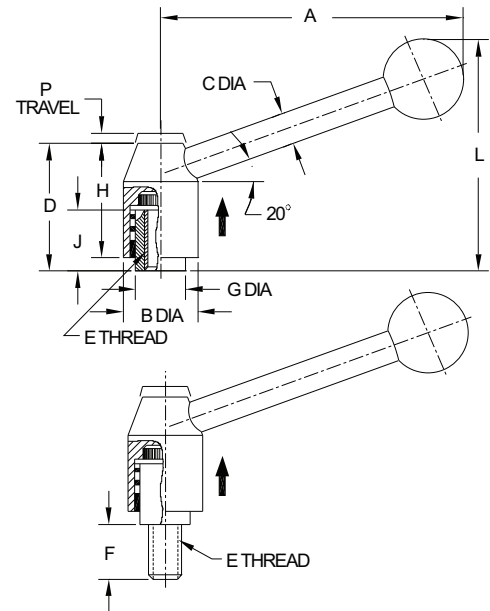
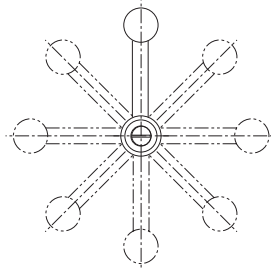

Heavy-duty stainless steel adjustable handle that can be reset to any angle. Ideal for clamping in a confined space, or when a specific handle position is desired. Rugged spring-loaded spline mechanism. Lift handle to disengage serrations, rotate to desired position, then release handle to automatically re-engage spline. Available with a tapped hole or an integral stud.

STAINLESS STEEL — TAPPED (INCH)

PART NO.	SIZE	A	B DIA	C DIA	D	E	F	G	H	J	L	N DIA	P
CL-6-AHL-3-S	3	3.94	.94	.39	1.57	3/8-16	—	.63	.10	.55	2.95	.98	.18
CL-8-AHL-4-S	4	4.53	1.10	.47	1.91	1/2-13	—	.75	.18	.67	3.54	1.18	

BALL KNOBS

BLACK PHENOLIC, THERMOPLASTIC, OR CUSHION GRIP PLASTIC WITH BRASS INSERT

Phenolic — Tapped



3/8-16 CL-852-PB
3/8-24 CL-854-PB
1/2-13 CL-872-PB
5/8-18 CL-882-PB
M10 CLM-852-PB
M12 CLM-872-PB
M16 CLM-882-PB



3/8-16 CL-752-PB
1/2-13 CL-772-PB
M10 CLM-752-PB
M12 CLM-772-PB



1/4-20 CL-632-PB
5/16-18 CL-642-PB
3/8-16 CL-652-PB
3/8-24 CL-654-PB
1/2-13 CL-672-PB
1/2-20 CL-674-PB
M10 CLM-652-PB
M12 CLM-672-PB



1/4-20 CL-532-PB
5/16-18 CL-542-PB
3/8-16 CL-552-PB
3/8-24 CL-554-PB
M8 CLM-542-PB
M10 CLM-552-PB



#10-32 CL-424-PB
1/4-20 CL-432-PB
1/4-28 CL-234-PB
5/16-18 CL-442-PB
5/16-24 CL-444-PB
3/8-16 CL-452-PB
M6 CLM-432-PB
M8 CLM-442-PB



#8-32 CL-212-PB
#10-32 CL-224-PB
1/4-20 CL-232-PB
M5 CLM-222-PB
M6 CLM-232-PB

Phenolic — Tapped Recessed Top



3/8-16 CL-856-PB
3/8-24 CL-858-PB
1/2-13 CL-876-PB

Durable multi-purpose knob, suitable for many applications. Molded-in brass insert provides superior thread strength. Choice of seven ball sizes. The largest size is available with a recessed top (1-1/4" dia) for adding custom decals or inlays. Non-standard thread sizes, molded-in studs, or special colors (thermoplastic and cushion grip only) are available in quantities of 500 and above.

Choose From Three Materials

1. Phenolic plastic — glossy smooth finish, extremely hard, electrical insulator, operating temperatures to 300°F, resistant to oils and most common chemicals.
2. Thermoplastic — textured surface for improved gripping, excellent impact resistance, operating temperatures to 150°F.
3. Cushion Grip — unique plastic that feels soft to the touch, matte finish, comfortable yet rugged, excellent impact resistance, operating temperatures to 150°F, excellent gripability even when wet or oily, absorbs vibration.

PHENOLIC — TAPPED (INCH & METRIC)

PART NO.	A DIA	B	C DIA	D	E			
CL-212-PB	3/4	#8-32	3/8	5/16	45/64			
CL-224-PB		#10-32						
CL-232-PB		1/4-20						
CLM-222-PB		M5						
CLM-232-PB		M6						
CL-424-PB	1	#10-32	1/2	7/16	31/32			
CL-432-PB		1/4-20						
CL-234-PB		1/4-28						
CL-442-PB		5/16-18						
CL-444-PB		5/16-24						
CL-452-PB		3/8-16						
CLM-432-PB		M6						
CLM-442-PB		M8						
CL-532-PB		1/4-20				9/16	1/2	1-1/8
CL-542-PB		5/16-18						
CLM-542-PB	M8							
CL-632-PB	1-3/8	1/4-20	5/8	7/16	1-19/64			
CL-642-PB		5/16-18						
CL-652-PB		3/8-16						
CL-654-PB		3/8-24						
CL-672-PB		1/2-13						
CL-674-PB		1/2-20						
CLM-652-PB		M10						
CLM-672-PB		M12						
CL-752-PB	1-5/8	3/8-16	11/16	5/8	1-37/64			
CL-772-PB		1/2-13						
CLM-772-PB		M12						
CL-852-PB	1-7/8	3/8-16	3/4	5/8	1-51/64			
CL-854-PB		3/8-24						
CL-872-PB		1/2-13						
CL-882-PB*		5/8-18						
CLM-852-PB		M10						

* This size is solid plastic, without a brass insert.

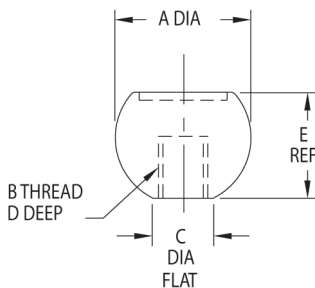
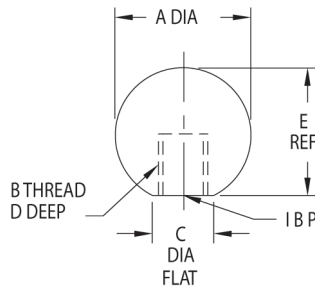

PHENOLIC — TAPPED RECESSED TOP (INCH)

PART NO.	A DIA	B	C DIA	D	E
CL-856-PB	1-7/8	3/8-16	3/4	1/2	1-15/32
CL-858-PB		3/8-24			
CL-876-PB		1/2-13			

BALL KNOBS

BLACK PHENOLIC, THERMOPLASTIC, OR CUSHION-GRIP PLASTIC WITH BRASS INSERT

Thermoplastic — Tapped



1/4-20 CL-6320-PB
 5/16-18 CL-6420-PB
 3/8-16 CL-6520-PB
 1/2-13 CL-6720-PB

Ball Knobs are now available in three materials: phenolic plastic, thermoplastic, and cushion-grip plastic.

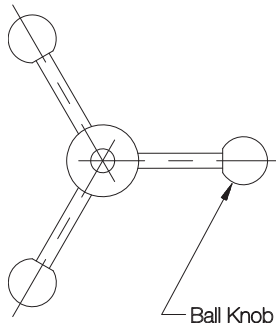
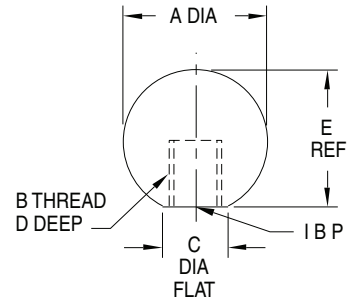

Cushion Grip — Tapped

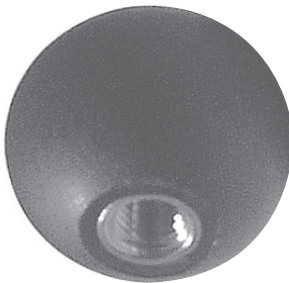

1/4-20 CL-6325-PB
 5/16-18 CL-6425-PB
 3/8-16 CL-6525-PB
 1/2-13 CL-6725-PB

THERMOPLASTIC — TAPPED (INCH)

PART NO.	A DIA	B	C DIA	D	E
CL-6420-PB	1-1/2	5/16-18	5/8	5/8	1-15/64
CL-6520-PB		3/8-16			

CUSHION GRIP — TAPPED (INCH)

PART NO.	A DIA	B	C DIA	D	E
CL-6325-PB	1-1/2	1/4-20	5/8	5/8	1-15/64
CL-6425-PB		5/16-18			
CL-6525-PB		3/8-16			
CL-6725-PB		1/2-13			

OVAL BALL KNOBS

BLACK PHENOLIC PLASTIC WITH BRASS INSERT

Phenolic — Tapped



3/8-16 CL-852-OBK
 3/8-24 CL-854-OBK
 1/2-13 CL-872-OBK



1/4-20 CL-532-OBK
 5/16-18 CL-542-OBK
 3/8-16 CL-552-OBK

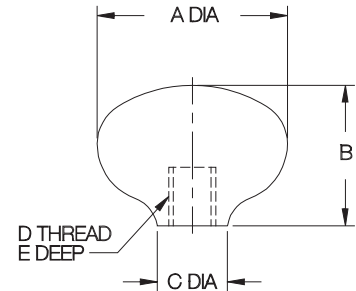
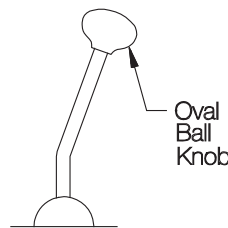

PHENOLIC — TAPPED (INCH)

PART NO.	A DIA	B	C DIA	D	E
CL-532-OBK	1-1/8	1-7/16	1/2	1/4-20	7/16
CL-542-OBK				5/16-18	
CL-552-OBK				3/8-16	1/2
CL-852-OBK	2-1/32	1-1/2	3/4	3/8-16	1/2
CL-854-OBK				3/8-24	
CL-872-OBK				1/2-13	5/8

Comfortable-grip ball knobs that are ideal for shift levers, control levers and push/pull rods. Molded-in brass insert provides superior thread strength. Choice of two shapes. Non-standard thread sizes or molded-in studs are available in quantities of 500 and above.

BALL KNOBS

1018 STEEL, BLACK OXIDE FINISH, OR 316 STAINLESS STEEL



Steel — Tapped

1/4-20	CL-632-SBK
5/16-18	CL-642-SBK
3/8-16	CL-652-SBK
1/2-13	CL-672-SBK
M6	CLM-632-SBK
M8	CLM-642-SBK
M10	CLM-652-SBK
M12	CLM-672-SBK

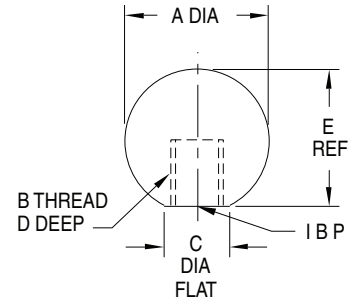

Heavy-duty knob handle made of steel with a black oxide finish. This durable, multi-purpose knob is suitable for many applications. Ideal when added weight is desirable for easier lever actuation.

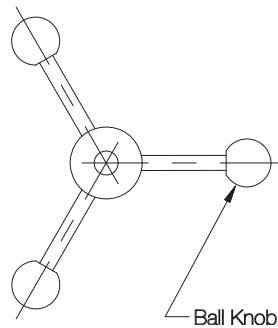

STEEL — TAPPED (INCH)

PART NO.	A DIA	B	C DIA	D	E
CL-632-SBK	1-1/2	1/4-20	5/8	9/16	1-7/16
CL-642-SBK		5/16-18			
CL-652-SBK		3/8-16			
CL-672-SBK		1/2-13			

STEEL — TAPPED (METRIC)

PART NO.	A DIA	B	C DIA	D	E
CLM-672-SBK	1-1/2	M12	5/8	5/8	1-7/16



Stainless Steel — Tapped

1/4-20	CL-632-SBK-S
5/16-18	CL-642-SBK-S
3/8-16	CL-652-SBK-S
1/2-13	CL-672-SBK-S
M6	CLM-632-SBK-S
M8	CLM-642-SBK-S
M10	CLM-652-SBK-S
M12	CLM-672-SBK-S

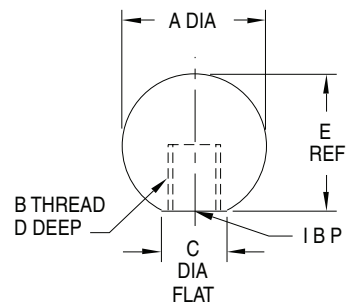

Heavy-duty knob handle made of type 316 stainless steel for excellent corrosion resistance. This durable, multi-purpose knob is suitable for many applications, including marine and chemical environments. Ideal when added weight is desirable for easier lever actuation. Attractive polished finish.

STAINLESS STEEL — TAPPED (INCH)

PART NO.	A DIA	B	C DIA	D	E
CL-632-SBK-S	1-1/2	1/4-20	5/8	9/16	1-7/16
CL-642-SBK-S		5/16-18			
CL-652-SBK-S		3/8-16			
CL-672-SBK-S		1/2-13			

OVAL TAPERED KNOBS

BLACK PHENOLIC OR CUSHION-GRIP PLASTIC WITH BRASS INSERT

Phenolic — Tapped

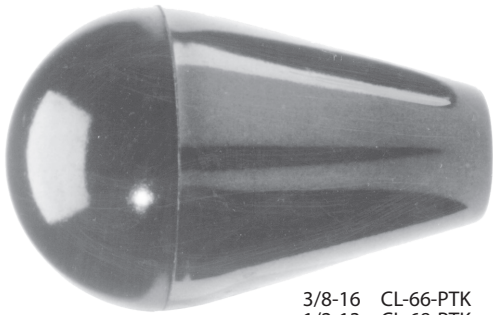

3/8-16 CL-66-PTK
1/2-13 CL-68-PTK
M10 CLM-610-PTK
M12 CLM-612-PTK

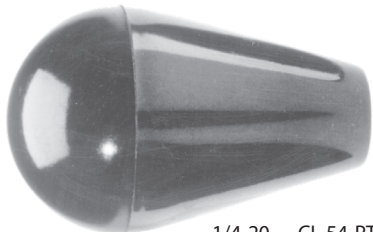

1/4-20 CL-54-PTK
5/16-18 CL-55-PTK
M8 CLM-58-PTK

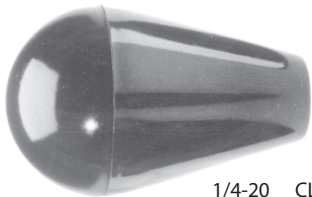

1/4-20 CL-44-PTK
5/16-18 CL-45-PTK
3/8-16 CL-46-PTK
M6 CLM-46-PTK

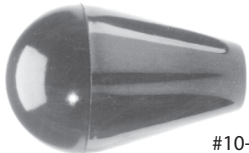

#10-32 CL-23-PTK
1/4-20 CL-24-PTK
M6 CLM-26-PTK

Cushion Grip — Tapped

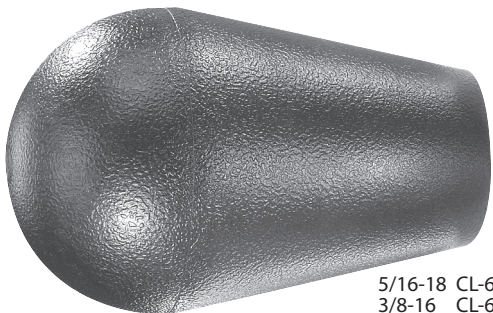

5/16-18 CL-650-PTK
3/8-16 CL-660-PTK

Attractive design suitable for control levers and push/pull rods. Molded-in brass insert provides superior thread strength. The solid-plastic through-hole version can be used with a Shoulder Screw as a revolving crank handle. Choice of four knob sizes. Non-standard thread sizes, molded-in studs, or special colors (cushion grip only) are available in quantities of 500 and above.

Phenolic — Through Hole

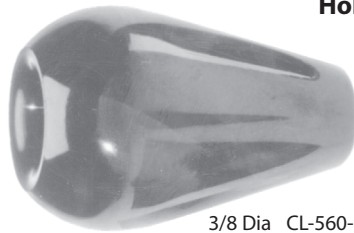

3/8 Dia CL-560-PTK

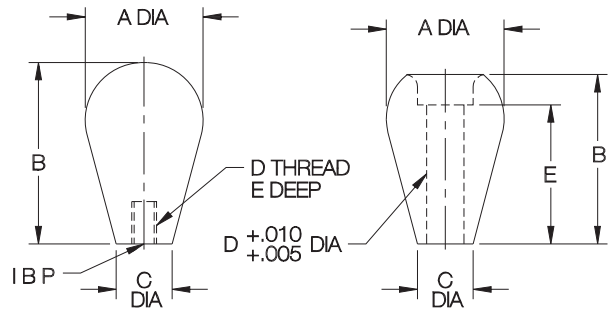
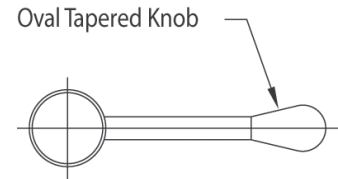

PHENOLIC — TAPPED (INCH & METRIC)

PART NO.	A DIA	B	C DIA	D	E
CL-23-PTK	3/4	1-1/4	3/8	#10-32	5/16
CL-24-PTK*				1/4-20	7/16
CLM-26-PTK*				M6	
CL-44-PTK	1	1-5/8	1/2	1/4-20	7/16
CL-45-PTK				5/16-18	
CL-46-PTK				3/8-16	
CLM-46-PTK				M6	
CL-54-PTK	1-3/16	1-7/8	9/16	1/4-20	7/16
CL-55-PTK				5/16-18	
CLM-58-PTK				M8	
CL-66-PTK	1-5/8	2-1/2	7/8	3/8-16	1/2
CL-68-PTK				1/2-13	5/8
CLM-610-PTK				M10	1/2
CLM-612-PTK				M12	5/8

PHENOLIC — THROUGH HOLE

CL-560-PTK*	1-3/16	1-3/4	9/16	.375	1-7/16
-------------	--------	-------	------	------	--------

CUSHION GRIP — TAPPED (INCH)

CL-650-PTK	1-5/8	2-1/2	7/8	5/16-18	5/8
CL-660-PTK				3/8-16	

* These sizes are solid plastic, without a brass insert.

TAPERED KNOBS

BLACK CUSHION-GRIP PLASTIC WITH BRASS INSERT

Cushion Grip — Tapped

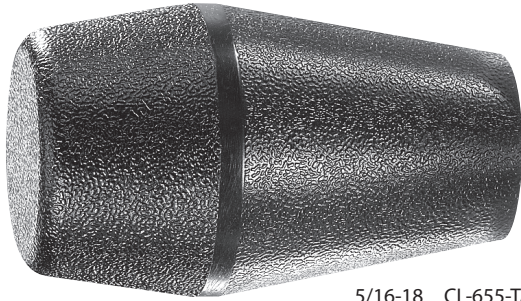

5/16-18 CL-655-TAPK
 3/8-16 CL-665-TAPK
 1/2-13 CL-685-TAPK

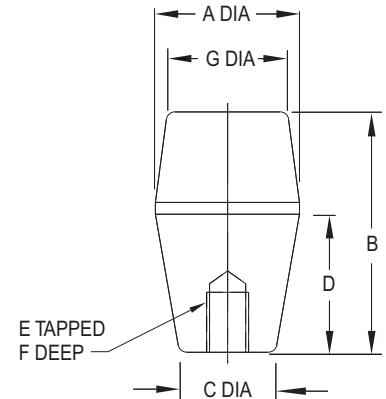

Attractive square design, ideal for lever handles. Made from Cushion Grip plastic, a unique material that feels soft to the touch, comfortable yet rugged. Textured non-slip, non-glare finish. Molded-in brass insert provides superior thread strength. Non-standard thread sizes, molded-in studs, or special colors are available in quantities of 500 and above.

CUSHION GRIP — TAPPED (INCH)

PART NO.	A DIA	B	C DIA	D DIA	E	F	G DIA
CL-655-TAPK					5/16-18	3/4	
CL-665-TAPK	1-1/2	2-1/2	15/16	1-1/2	3/8-16	5/8	1-1/8
CL-685-TAPK					1/2-13		

PALM-GRIP HANDLES

BLACK THERMOPLASTIC WITH BRASS INSERT

Thermoplastic — Tapped



1/4-20 CL-632-PGH
 5/16-18 CL-642-PGH
 3/8-16 CL-652-PGH

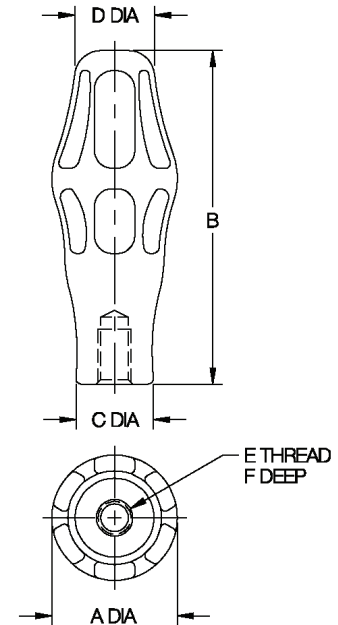

This unique, ergonomically designed handle provides an extremely comfortable grip. Greatly reduces stress on hands, wrists, and arms to help eliminate the risk of repetitive-motion disorders. Textured non-slip, non-glare finish. Molded-in brass insert provides superior thread strength. Non-standard thread sizes, molded-in studs, or special colors are available in quantities of 500 and above.

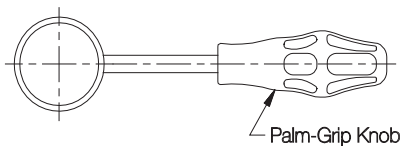

THERMOPLASTIC — TAPPED (INCH)

PART NO.	A DIA	B	C DIA	D DIA	E	F
CL-632-PGH					1/4-20	7/8
CL-642-PGH	1-3/8	3-3/4	7/8	7/8	5/16-18	5/8
CL-652-PGH					3/8-16	

KNOB HANDLES

BLACK CUSHION-GRIP PLASTIC. TAPPED VERSION WITH BRASS INSERT

3



5/16-18 CL-855-KH
3/8-16 CL-865-KH
3/8 DIA CL-866-KH



5/16-18 CL-655-KH
3/8-16 CL-665-KH
3/8 DIA CL-666-KH



5/16-18 CL-455-KH
3/8-16 CL-465-KH
3/8 DIA CL-466-KH

**Cushion Grip —
Tapped or Cored**

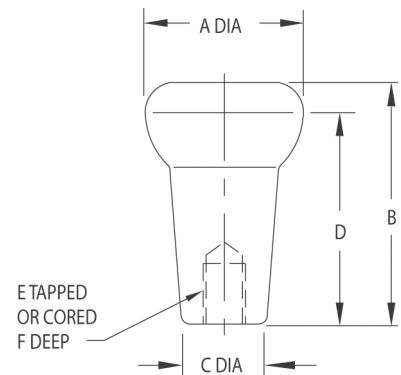

Tapered handle with a knob end for secure gripping. Made from Cushion-Grip plastic, a unique material that feels soft to the touch, comfortable yet rugged. Non-slip, non-glare finish. Molded-in brass insert on the tapped version provides superior thread strength. Optionally available with a plain cored hole to press fit on a shaft. The cored hole is somewhat undersize to grip tightly on a nominal-size shaft without requiring pinning. Non-standard thread sizes, molded-in studs, or special colors are available in quantities of 500 and above.

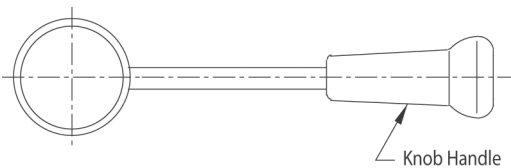

Combination knob and tapered handle. The knob end helps prevent operator's hand from sliding off the handle.

CUSHION GRIP — TAPPED (INCH)

PART NO.	A DIA	B	C DIA	D	E	F
CL-455-KH	1-3/8	2-1/8	13/16	11-1/4	5/16-18	5/8
CL-465-KH					3/8-16	
CL-665-KH	1-5/8	2-1/2	7/8	1-1/2	3/8-16	7/16
CL-855-KH	1-1/2	4-3/8		3-1/2	5/16-18	
CL-865-KH			3/8-16	1/2		

CUSHION GRIP — CORED

PART NO.	A DIA	B	C DIA	D	E		F
					FOR SHAFT DIA	ACTUAL DIA	
CL-466-KH	1-3/8	2-1/8	13/16	1-1/4	3/8	.312-.327	1
CL-666-KH	1-5/8	2-1/2	7/8	1-1/2			

TAPERED HANDLES

BLACK PHENOLIC PLASTIC WITH BRASS INSERT



1/2-13 CL-3-PH
M10 CLM-10-PH



3/8-16 CL-2-PH
M8 CLM-8-PH



1/4-20 CL-1-PH
5/16-18 CL-15-PH
3/8-16 CL-16-PH
M6 CLM-6-PH
M8 CLM-18-PH



1/4-20 CL-0-PH
5/16-18 CL-05-PH
M6 CLM-06-PH
M8 CLM-08-PH



#10-32 CL-00-PH
M5 CLM-005-PH

Phenolic —
Tapped

Heavy-duty design that makes an excellent grasp handle or machine shift lever. Molded-in brass insert provides superior thread strength. The solid-plastic through-hole version can be used with a Shoulder Screw as a revolving crank handle. Choice of five handle sizes. Non-standard thread sizes or molded-in studs are available in quantities of 500 and above.

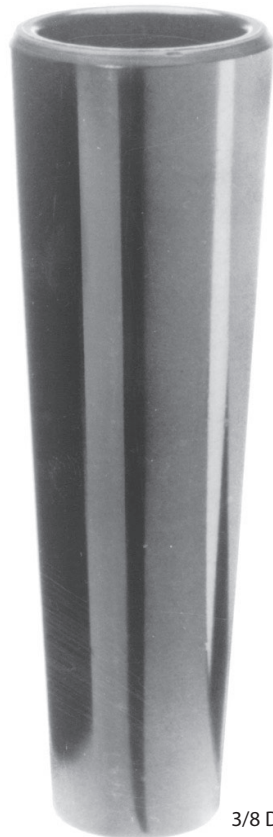
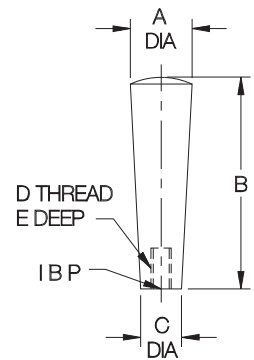

3/8 Dia CL-30-PH



3/8 Dia CL-20-PH

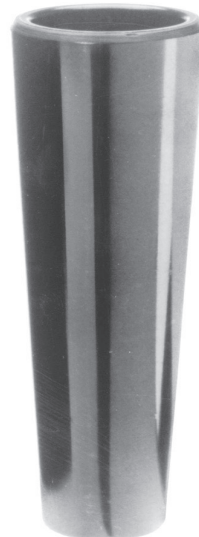

1/4 Dia CL-10-PH

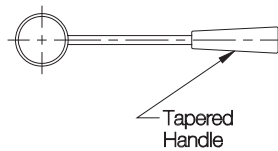

Phenolic —
Through Hole

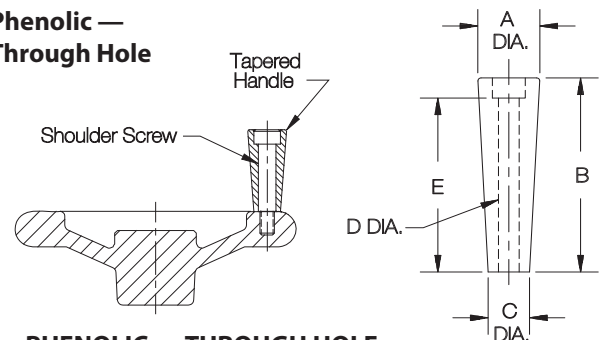

PHENOLIC — TAPPED (INCH & METRIC)

PART NO.	A DIA	B	C DIA	D	E
CL-00-PH	3/4	7/8	3/8	#10-32	5/16
CLM-005-PH				M5	
CL-0-PH	1	1-1/4	1/2	1/4-20	7/16
CL-05-PH				5/16-18	
CLM-06-PH				M6	3/8
CLM-08-PH				M8	
CL-1-PH	1	2-5/8	5/8	1/4-20	7/16
CL-15-PH				5/16-18	
CL-16-PH				3/8-16	1/2
CLM-6-PH				M6	7/16
CLM-18-PH				M8	
CL-2-PH	1-1/8	3-7/8	3/4	3/8-16	5/8
CLM-8-PH				M8	7/16
CL-3-PH	1-3/8	4-1/2	1	1/2-13	2
CLM-10-PH				M10	

PHENOLIC — THROUGH HOLE

PART NO.	A DIA	B	C DIA	D		E
				NOMINAL	ACTUAL	
CL-10-PH*	1	2-9/16	5/8	1/4	.251/.256	5/8
CL-20-PH*	1-1/8	3-11/16	3/4	3/8	.380/.385	2-5/8
CL-30-PH*	1-3/8	4-3/32	1	3/8	.380/.390	2-5/8

* This size is solid plastic, without a brass insert.

3

PULL KNOBS

BLACK PHENOLIC PLASTIC WITH BRASS INSERT



**Phenolic—Tapped
Flat Top**

1/4-20 CL-632-PK
5/16-18 CL-642-PK
3/8-16 CL-652-PK
M8 CLM-642-PK

#10-32 CL-424-PK
1/4-20 CL-432-PK
M5 CLM-422-PK
M6 CLM-432-PK

Versatile knob with an enlarged head for pulling, pushing, or lifting. Molded-in brass insert provides superior thread strength. Choice of three types, in two sizes each. Non-standard thread sizes or molded-in studs are available in quantities of 500 and above.

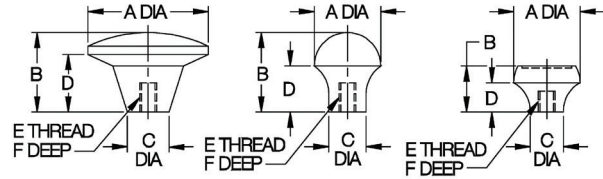

3



**Phenolic—Tapped
Oval Top**

3/8-24 CL-654-PKO

#10-32 CL-424-PKO
1/4-20 CL-432-PKO
M5 CLM-422-PKO
M6 CLM-432-PKO

PHENOLIC — TAPPED, FLAT TOP (INCH & METRIC)

PART NO.	A DIA	B	C DIA	D	E	F
CL-424-PK	1-3/8	7/8	5/8	5/8	#10-32	5/16
CL-432-PK					1/4-20	7/16
CLM-422-PK					M5	5/16
CLM-432-PK					M6	7/16
CL-632-PK	1-13/16	1-3/16	5/8	7/8	1/4-20	7/16
CL-642-PK					5/16-18	
CL-652-PK					3/8-16	1/2
CLM-642-PK					M8	

PHENOLIC — TAPPED, OVAL TOP (INCH & METRIC)

CL-424-PKO	1	1-3/16	9/16	11/16	#10-32	5/16
CL-432-PKO					1/4-20	7/16
CLM-422-PKO					M5	5/16
CLM-432-PKO					M6	7/16
CL-654-PKO	1-5/8	1	5/8	3/8	3/8-24	1/2



**Phenolic—Tapped
Recessed Top**

#10-32 CL-424-PKR
1/4-20 CL-432-PKR

#6-32 CL-202-PKR
#8-32 CL-212-PKR
#10-32 CL-224-PKR
1/4-20 CL-232-PKR

PHENOLIC — TAPPED, RECESSED TOP (INCH)

CL-202-PKR	3/4	3/4	1/2	21/32	#6-32	5/16
CL-212-PKR					#8-32	
CL-224-PKR					#10-32	
CL-232-PKR					1/4-20	
CL-424-PKR	1	11/16	1/2	7/16	#10-32	5/16
CL-432-PKR					1/4-20	

T HANDLES

BLACK PHENOLIC PLASTIC WITH BRASS INSERT



Phenolic—Tapped

Easy-gripping handle for push/pull applications, such as release latches and cabinet doors. Molded-in brass insert provides superior thread strength. Non-standard thread sizes or molded-in studs are available in quantities of 500 and above.

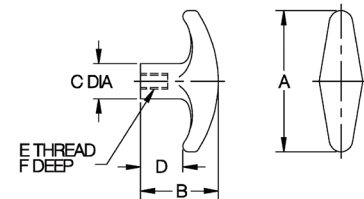

#10-32 CL-424-TH
1/4-20 CL-432-TH
1/4-28 CL-434-TH
5/16-18 CL-442-TH
M5 CLM-422-TH
M6 CLM-432-TH
M8 CLM-442-TH

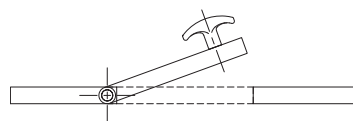

PHENOLIC — TAPPED (INCH & METRIC)

PART NO.	A	B	C DIA	D	E	F
CL-424-TH	2-1/4	1-1/4	9/16	11/16	#10-32	5/16
CL-432-TH					1/4-20	
CL-434-TH					1/4-28	7/16
CL-442-TH					5/16-18	5/16
CLM-422-TH					M5	
CLM-432-TH					M6	
CLM-442-TH					M8	

PULL HANDLES

BLACK THERMOPLASTIC WITH BRASS INSERT



**Square Design
Thermoplastic
Tapped**

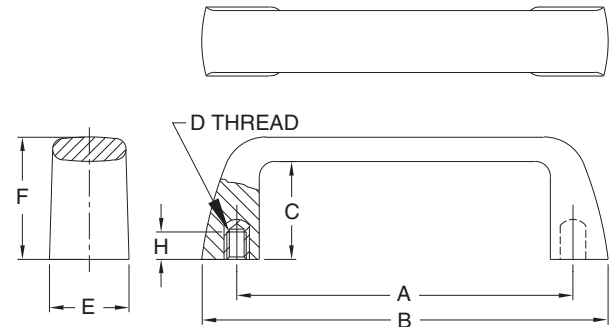

TAPPED (INCH)

PART NO.	A	B	C	D	E	F	H
CL-105-PHS-4	4.13	4.76	1.14	1/4-20	1.02	1.46	.35
CL-117-PHS-5	4.61	5.24	1.26	5/16-18		1.57	

Attractive, modern-design handle that provides a comfortable grip with good ergonomic features. Excellent durability. Textured non-slip, non-glare finish. Molded-in brass insert provides superior thread strength. Black fiber-reinforced nylon thermoplastic (textured surface for secure gripping, excellent impact resistance, operating temperatures to 230°F). Choice of two handle sizes, available with either inch or metric threads.

TAPPED (METRIC)

PART NO.	A (mm)	B (mm)	C (mm)	D THREAD	THREAD PITCH (mm)	E (mm)	F (mm)	H (mm)
CLM-105-PHS-6	105	121	29	M6	1	26	37	9
CLM-117-PHS-8	117	133	32	M8	1.25	26	40	9

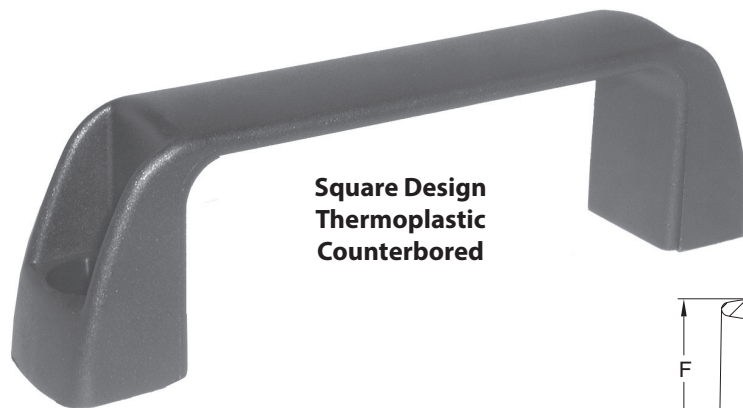

**Square Design
Thermoplastic
Counterbored**

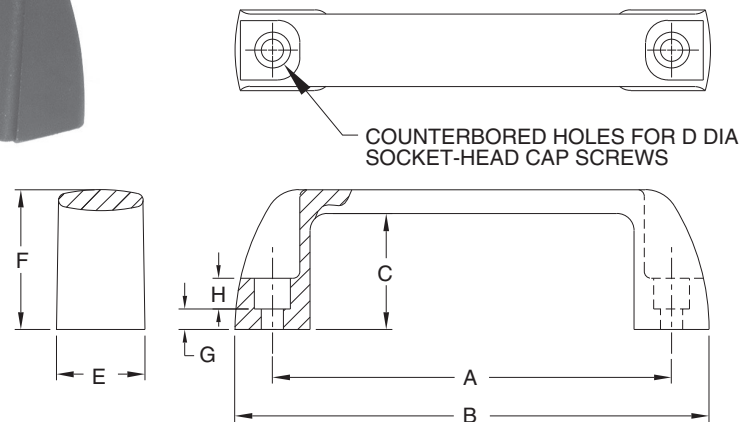

COUNTERBORED

PART NO.	A	B	C	D DIA	E	F	G	H
CL-94-PHSC-4	3.68	4.41	1.18	1/4 or M6	.83	1.42	.24	.28
CL-117-PHSC-5	4.61	5.47	1.34		1.02	1.61	.24	
CL-132-PHSC-5	5.20	6.14	1.46	5/16 or M8	1.06	1.77	.28	
CL-179-PHSC-5	7.05	8.03	1.65		1.10	1.97	.31	

Attractive, modern-design handle that provides a comfortable grip with good ergonomic features. Excellent durability. Textured non-slip, non-glare finish. Counterbored for Socket-Head Cap Screws. Choice of four handle sizes. Black fiber-reinforced nylon thermoplastic (textured surface for secure gripping, excellent impact resistance, operating temperatures to 230°F).

PULL HANDLES

ALUMINUM, BLACK POWDER-COATED FINISH, OR 304 STAINLESS STEEL

3



**Rounded Design
Aluminum
Tapped**



**Rounded Design
Stainless Steel
Tapped**

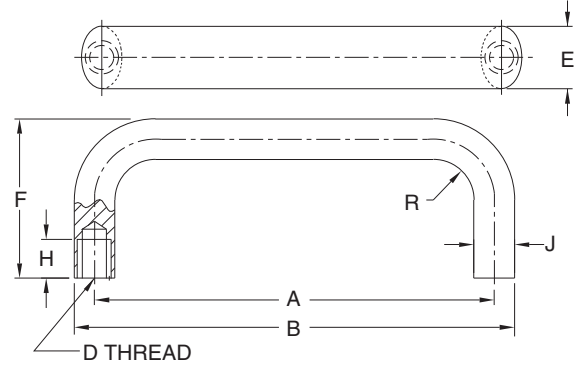

ALUMINUM — TAPPED (INCH)

PART NO.	A	B	D	E	F	H	J	R
CL-112-PHR-4	4.41	4.92	1/4-20	.79	1.93	.39	.51	.51
CL-128-PHR-4	5.04	5.55			2.01			
CL-160-PHR-5	6.30	6.97	5/16-18	1.02	2.24	.47	.67	.67
CL-192-PHR-5	7.56	8.23						

ALUMINUM — TAPPED (METRIC)

PART NO.	A (mm)	B (mm)	D THREAD	THREAD PITCH (mm)	E (mm)	F (mm)	H (mm)	J (mm)	R (mm)
CLM-112-PHR-6	112	125	M6	1	20	49	10	13	13
CLM-128-PHR-6	128	141	M6	1	20	51	10	13	13
CLM-160-PHR-8	160	177	M8	1.25	26	57	12	17	17
CLM-192-PHR-8	192	209	M8	1.25	26	57	12	17	17

STAINLESS STEEL — TAPPED (METRIC)

PART NO.	A (mm)	B (mm)	D THREAD	THREAD PITCH (mm)	E (mm)	F (mm)	H (mm)	J (mm)	R (mm)
CLM-112-PHR-6-S	112	125	M6	1	20	49	10	13	13
CLM-128-PHR-6-S	128	141	M6	1	20	51	10	13	13

Attractive, modern-design aluminum handle provides a comfortable grip with good ergonomic features. Durable black powder-coated pebble finish. Tapped holes for mounting. Choice of four handle sizes, available with either inch or metric threads. Also available in stainless steel, shot blasted with a satin finish (two sizes).



**Rounded Design
Aluminum
Counterbored**

COUNTERBORED HOLES FOR D DIA SOCKET HEAD CAP SCREWS

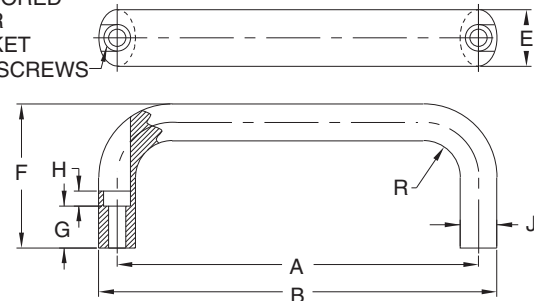

ALUMINUM — COUNTERBORED

PART NO.	A	B	D	E	F	G	H	J	R
CL-116-PHRC-4	4.57	5.12	1/4 or M6	1.02	2.17	.43	.24	.67	.67
CL-132-PHRC-4	5.20	5.75			2.24				
CL-164-PHRC-4	6.46	7.01							
CL-196-PHRC-4	7.72	8.27							

Similar to the handles above, except counterbored for Socket-Head Cap Screws. Attractive, modern-design aluminum handle provides a comfortable grip with good ergonomic features. Durable black powder-coated pebble finish. Choice of four handle sizes.

SPRING-LOADED DEVICES



Spring Plungers



Ball Plungers



**Hand-Retractable
Plungers**



Index Plungers



Spring Stop Buttons



Spring Locating Pins

Also see:



**Adjustable-Torque
Thumb Screws
p. 127**



**Adjustable-Torque
Knobs
p. 128**

SPRING PLUNGERS

TYPES



STANDARD

Long bearing length on plunger for smooth operation. Locking element holds the unit securely in place after installation. Install and/or adjust from either end (when using the slot at the plunger end).



SHORT

Compact, short-stroke version of our standard Spring Plungers. Self-contained plunger-and-spring device available in many sizes and forces. Locking element holds the unit securely in place after installation.

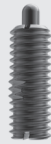

SHORT WITH EXTENDED TRAVEL

This self-contained plunger-and-spring device is available in a wide range of sizes. Locking element holds the unit securely in place after installation.



PRESS FIT

Sturdy shoulder provides a fixed seating position and positively resists detent force (installation hole can be counterbored to recess the shoulder).

SELECTION CHART

STYLE	OD																
	#6-32	#8-32	#8-36	#10-32	M5	1/4-20	M6	1/4-28	5/16-18	M8	3/8-16	M10	1/2-13	M12	5/8-11	3/4-10	1"-8
Spring Plunger																	
Steel Nose	X	X		X		X	X	X	X	X	X	X	X	X	X	X	X
Stainless Steel	X	X		X		X	X	X	X	X	X	X	X				
Delrin® Nose		X		X		X	X		X	X	X	X	X	X	X		
Stainless Steel, Delrin® Nose		X		X		X	X		X	X	X	X	X	X			
Short Spring Plunger																	
Steel Nose		X	X	X	X	X	X		X	X	X	X	X				
Stainless Steel		X	X	X	X	X			X		X		X				
Delrin® Nose		X	X	X	X	X	X		X	X	X	X	X		X		
Stainless Steel, Delrin® Nose		X	X	X	X	X			X		X		X				
Extended Travel, Steel Nose		X	X	X	X	X	X		X	X	X	X	X		X		
Extended Travel, Stainless Steel		X	X	X	X	X			X		X		X				
Extended Travel, Delrin® Nose		X	X	X	X	X	X		X	X	X	X	X		X		
Extended Travel, Stainless Steel, Delrin® Nose		X	X	X	X	X			X		X		X				
Press Fit Spring Plunger																	
Steel Nose		1/8"		3/16"		1/4"			5/16"		3/8"		1/2"				
Stainless Steel		1/8"		3/16"		1/4"			5/16"		3/8"		1/2"				
Delrin® Nose		1/8"		3/16"		1/4"			5/16"		3/8"		1/2"				
Stainless Steel, Delrin® Nose		1/8"		3/16"		1/4"			5/16"		3/8"		1/2"				

SPRING PLUNGERS

TECHNICAL INFORMATION

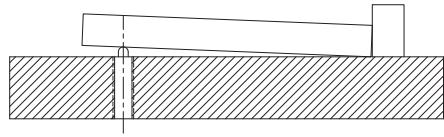

Spring plungers are often used to lift parts after machining to make unloading easier.

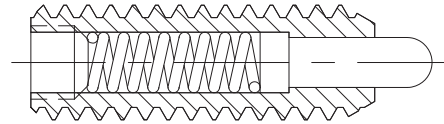

Nose Extended

Spring Plungers are self-contained plunger-and-spring devices that apply force over a relatively wide range of travel. The plunger nose has a long bearing length to provide smooth, linear operation. Spring Plungers are available in a wide range of sizes and forces, most in a choice of light or heavy end force. A Spring Plunger's end force is very consistent -- beginning at the stated "initial" value, and increasing linearly (due to spring compression) through the range of travel, until it reaches the stated "final" value at maximum travel.

Most Spring Plungers have a locking element to hold it securely in place after installation. This element is a locking patch on small diameters and a nylon locking pellet on larger sizes. To obtain full holding torque on sizes with a locking pellet, countersink the installation hole to avoid cutting the pellet. Countersink at a 90° angle to a diameter 1/32" larger than the major thread diameter. Then, as you screw the plunger into its hole, the locking pellet will be compressed, no cut. The locking pellet does not apply excessive force, so it also works well in softer metals such as aluminum.

Spring Plungers are recommended only for applying straight-line force, not for sideways breakaway from a detent position. For breakaway applications, the rolling ball and short stroke of a Ball Plunger are crucial features for smooth, repeatable operation.

4

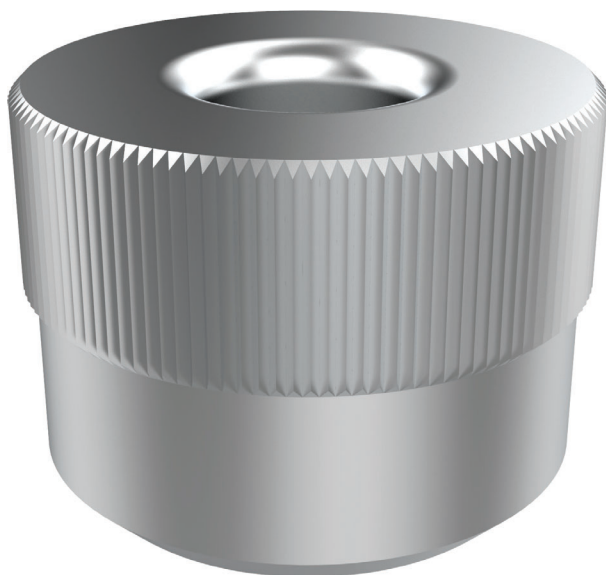

Quick-Ship Bushings

In-Stock and Ready for Same-Day Shipping

CarrLane
MANUFACTURING CO.

SPRING PLUNGERS

STEEL – BODY: 1215 STEEL, BLACK OXIDE FINISH (METRIC SIZES ZINC PLATED CLEAR CHROMATE).
 PLUNGER NOSE: 1215 STEEL, CARBURIZED-HARDENED, BLACK OXIDE FINISH OR ZINC PLATED CLEAR CHROMATE (OR DELRIN®). SPRING: MUSIC WIRE.
 STAINLESS STEEL – BODY: 300-SERIES STAINLESS.
 PLUNGER NOSE: 300-SERIES STAINLESS (OR DELRIN®). SPRING: 302 STAINLESS.



4

Self-contained plunger-and-spring device available in many sizes and forces. Long bearing length on plunger for smooth operation. Locking element holds the unit securely in place after installation. Install and/or adjust from either end (when using the slot at the plunger end, install with a Plunger Wrench to avoid over-compressing the spring).

Available in thread sizes from #6-32 to 1"-8 (M6 to M12 in metric). Choice of light or heavy force in each thread size. Available in steel, with hardened plunger nose, or stainless steel. Optionally available with a Delrin® nose to prevent marring.

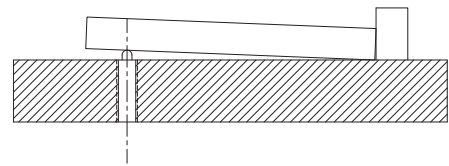

Spring plungers are often used to lift parts after machining to make unloading easier.

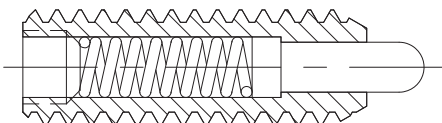

Nose Extended

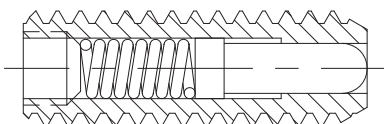

Nose Retracted

PLUNGER NOSE

BODY	NOSE	FORCE
STEEL	STEEL	LIGHT
		HEAVY
STEEL	DELRIN®	LIGHT
		HEAVY
STAINLESS	STAINLESS	LIGHT
		HEAVY
STAINLESS	DELRIN®	LIGHT
		HEAVY

SPRING PLUNGERS

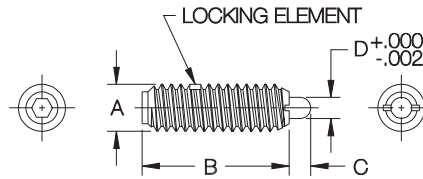

STANDARD PLUNGER NOSE, LIGHT FORCE (INCH)

PART NO.		A	END FORCE (LBS)		B	C	D DIA
STEEL	STAINLESS		INITIAL	FINAL			
CL-10-SPS-2	CL-10-SSPS-2	#6-32	0.5	1.5	17/32	1/16	.046
CL-20-SPS-2	CL-20-SSPS-2	#8-32	0.7	2.3	5/8	3/32	.070
CL-30-SPS-2	CL-30-SSPS-2	#10-32	1.3	2.7	3/4	1/8	.093
CL-40-SPS-2	CL-40-SSPS-2	1/4-20	1	4	1	3/16	.119
CL-41-SPS-2	CL-41-SSPS-2	1/4-28					
CL-50-SPS-2	CL-50-SSPS-2	5/16-18	1.5	4.5	1	3/16	.135
CL-60-SPS-2	CL-60-SSPS-2	3/8-16	2.8	7.2	1-1/8	3/16	.186
CL-70-SPS-2	CL-70-SSPS-2	1/2-13	2.7	9.3	1-1/4	1/4	.248
CL-80-SPS-2	—	5/8-11	3.5	10.5	1-1/2	5/16	.310
CL-90-SPS-2	—	3/4-10	4	16	1-3/4	5/16	.374
CL-95-SPS-2	—	1"-8	4	31	2-13/32	1/2	.499

DELRIN® PLUNGER NOSE, LIGHT FORCE (INCH)

PART NO.		A	END FORCE (LBS)		B	C	D DIA
STEEL	STAINLESS		INITIAL	FINAL			
—	—	#6-32	—	—	—	—	—
CL-20-SPN-2	—	#8-32	0.7	2.3	5/8	3/32	.070
CL-30-SPN-2	—	#10-32	1.3	2.7	3/4	1/8	.093
CL-40-SPN-2	—	1/4-20	1	4	1	3/16	.119
—	—	1/4-28	—	—	—	—	—
CL-50-SPN-2	—	5/16-18	1.5	4.5	1	3/16	.135
CL-60-SPN-2	—	3/8-16	2.8	7.2	1-1/8	3/16	.186
CL-70-SPN-2	—	1/2-13	2.7	9.3	1-1/4	1/4	.248
CL-80-SPN-2	—	5/8-11	3.5	10.5	1-1/2	5/16	.310
—	—	3/4-10	—	—	—	—	—
—	—	1"-8	—	—	—	—	—

STANDARD PLUNGER NOSE, HEAVY FORCE (INCH)

PART NO.		A	END FORCE (LBS)		B	C	D DIA
STEEL	STAINLESS		INITIAL	FINAL			
CL-11-SPS-1	CL-11-SSPS-1	#6-32	1.0	1.6	3/8	1/16	.046
CL-10-SPS-1	CL-10-SSPS-1		1.5	4.5			
CL-20-SPS-1	CL-20-SSPS-1	#8-32	2.7	7.3	5/8	3/32	.070
CL-30-SPS-1	CL-30-SSPS-1	#10-32	2.9	11.1	3/4	1/8	.093
CL-42-SPS-1	CL-42-SSPS-1	1/4-20	2	9	3/4	1/8	.119
CL-40-SPS-1	CL-40-SSPS-1		3	13	1	3/16	
CL-41-SPS-1	CL-41-SSPS-1		1/4-28				
CL-50-SPS-1	CL-50-SSPS-1	5/16-18	3	15	1	3/16	.135
CL-60-SPS-1	CL-60-SSPS-1	3/8-16	5.5	14.5	1-1/8	3/16	.186
CL-70-SPS-1	CL-70-SSPS-1	1/2-13	6.6	17.4	1-1/4	1/4	.248
CL-80-SPS-1	—	5/8-11	10.5	25.5	1-1/2	5/16	.310
CL-90-SPS-1	—	3/4-10	6.7	37.3	1-3/4	5/16	.374
CL-95-SPS-1	—	1"-8	16	68	2-13/32	1/2	.499

DELRIN® PLUNGER NOSE, HEAVY FORCE (INCH)

PART NO.		A	END FORCE (LBS)		B	C	D DIA
STEEL	STAINLESS		INITIAL	FINAL			
—	—	#6-32	—	—	—	—	—
—	—	#8-32	—	—	—	—	—
CL-20-SPN-1	—	#8-32	2.7	7.3	5/8	3/32	.070
CL-30-SPN-1	—	#10-32	2.9	11.1	3/4	1/8	.093
—	—	1/4-20	—	—	—	—	—
CL-40-SPN-1	—		3	13	1	3/16	.119
—	—	1/4-28	—	—	—	—	—
CL-50-SPN-1	—	5/16-18	3	15	1	3/16	.135
CL-60-SPN-1	—	3/8-16	5.5	14.5	1-1/8	3/16	.186
CL-70-SPN-1	—	1/2-13	6.6	17.4	1-1/4	1/4	.248
CL-80-SPN-1	—	5/8-11	10.5	25.5	1-1/2	5/16	.310
—	—	3/4-10	—	—	—	—	—
—	—	1"-8	—	—	—	—	—

STANDARD PLUNGER NOSE, LIGHT FORCE (METRIC)

PART NO.		A	END FORCE (LBS)		B	C	D DIA
STEEL	STAINLESS		INITIAL	FINAL			
CLM-6-SPS-1	CLM-6-SSPS-1	M6	1.0	4.0	1	3/16	.119
CLM-8-SPS-1	CLM-8-SSPS-1	M8	1.5	4.5	1	3/16	.135
CLM-10-SPS-1	CLM-10-SSPS-1	M10	2.8	7.2	1-1/8	3/16	.186
CLM-12-SPS-1	CLM-12-SSPS-1	M12	2.7	9.3	1-1/4	1/4	.248

DELRIN® PLUNGER NOSE, LIGHT FORCE (METRIC)

PART NO.		A	END FORCE (LBS)		B	C	D DIA
STEEL	STAINLESS		INITIAL	FINAL			
CLM-6-SPN-1	—	M6	1.0	4.0	1	3/16	.119
CLM-8-SPN-1	—	M8	1.5	4.5	1	3/16	.135
CLM-10-SPN-1	—	M10	2.8	7.2	1-1/8	3/16	.186
CLM-12-SPN-1	—	M12	2.7	9.3	1-1/4	1/4	.248

STANDARD PLUNGER NOSE, HEAVY FORCE (METRIC)

PART NO.		A	END FORCE (LBS)		B	C	D DIA
STEEL	STAINLESS		INITIAL	FINAL			
CLM-6-SPS-2	CLM-6-SSPS-2	M6	3.0	13.0	1	3/16	.119
CLM-8-SPS-2	CLM-8-SSPS-2	M8	3.0	15.0	1	3/16	.135
CLM-10-SPS-2	CLM-10-SSPS-2	M10	5.5	14.5	1-1/8	3/16	.186
CLM-12-SPS-2	CLM-12-SSPS-2	M12	6.6	17.4	1-1/4	1/4	.248

DELRIN® PLUNGER NOSE, HEAVY FORCE (METRIC)

PART NO.		A	END FORCE (LBS)		B	C	D DIA
STEEL	STAINLESS		INITIAL	FINAL			
CLM-6-SPN-2	—	M6	3.0	13.0	1	3/16	.119
CLM-8-SPN-2	—	M8	3.0	15.0	1	3/16	.135
CLM-10-SPN-2	—	M10	5.5	14.5	1-1/8	3/16	.186
CLM-12-SPN-2	—	M12	6.6	17.4	1-1/4	1/4	.248

SHORT SPRING PLUNGERS

STEEL – BODY: 1215 STEEL, BLACK OXIDE FINISH. PLUNGER NOSE: 1215 STEEL, CARBURIZED-HARDENED, BLACK OXIDE FINISH OR ZINC PLATED CLEAR CHROMATE (OR DELRIN®). SPRING: MUSIC WIRE.

STAINLESS STEEL – BODY: 300-SERIES STAINLESS.

PLUNGER NOSE: 300-SERIES STAINLESS (OR DELRIN®). SPRING: 302 STAINLESS.



Compact, short-stroke version of our standard Spring Plungers. Self-contained plunger-and-spring device available in many sizes and forces. Locking element holds the unit securely in place after installation. Install and/or adjust from either end (when using the slot at the plunger end, install with a Plunger Wrench to avoid over-compressing the spring).

Available in thread sizes from #8-32 to 5/8-11 (M5 to M12 in metric). Choice of light or heavy force in each thread size. Available in steel, with a hardened plunger nose, or stainless steel. Optionally available with a Delrin® nose to prevent marring.

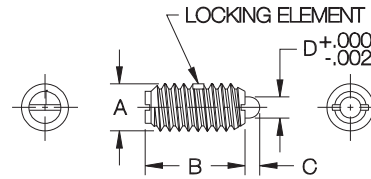
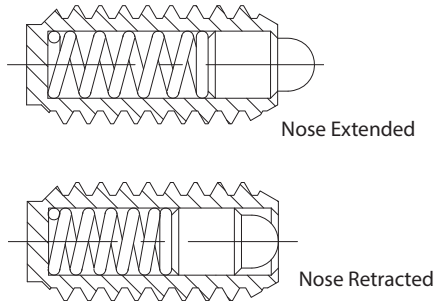

STANDARD PLUNGER NOSE, LIGHT FORCE (INCH)

PART NO.		A	END FORCE (LBS)		B	C	D DIA
STEEL	STAINLESS		INITIAL	FINAL			
CL-21-SPS-2	CL-21-SSPS-2	#8-32	0.5	1.5	7/16	.052	.070
CL-22-SPS-2	CL-22-SSPS-2	#8-36					
CL-31-SPS-2	CL-31-SSPS-2	#10-32	0.75	2.5	15/32	.065	.093
CL-43-SPS-2	CL-43-SSPS-2	1/4-20	1	3.5	17/32	.078	.119
CL-51-SPS-2	CL-51-SSPS-2	5/16-18	1.5	4	9/16	.084	.135
CL-61-SPS-2	CL-61-SSPS-2	3/8-16	1.5	5	5/8	.110	.186
CL-71-SPS-2	CL-71-SSPS-2	1/2-13	1.75	5.5	3/4	.151	.248
CL-81-SPS-2	—	5/8-11	2	8.5	1-1/16	.215	.310

DELRIN® PLUNGER NOSE, LIGHT FORCE (INCH)

PART NO.		A	END FORCE (LBS)		B	C	D DIA
STEEL	STAINLESS		INITIAL	FINAL			
CL-21-SPN-2	—	#8-32	0.5	1.5	7/16	.052	.070
CL-22-SPN-2	—	#8-36					
CL-31-SPN-2	—	#10-32	0.75	2.5	15/32	.065	.093
CL-43-SPN-2	—	1/4-20	1	3.5	17/32	.078	.119
CL-51-SPN-2	—	5/16-18	1.5	4	9/16	.084	.135
CL-61-SPN-2	—	3/8-16	1.5	5	5/8	.110	.186
CL-71-SPN-2	—	1/2-13	1.75	5.5	3/4	.151	.248
CL-81-SPN-2	—	5/8-11	2	8.5	1-1/16	.215	.310

STANDARD PLUNGER NOSE, HEAVY FORCE (INCH)

PART NO.		A	INITIAL	FINAL	B	C	D DIA
STEEL	STAINLESS						
CL-21-SPS-1	CL-21-SSPS-1	#8-32	1.5	4.75	7/16	.052	.070
CL-22-SPS-1	CL-22-SSPS-1	#8-36					
CL-31-SPS-1	CL-31-SSPS-1	#10-32	1.75	6.25	15/32	.065	.093
CL-43-SPS-1	CL-43-SSPS-1	1/4-20	3	10.5	17/32	.078	.119
CL-51-SPS-1	CL-51-SSPS-1	5/16-18	3.75	15.5	9/16	.084	.135
CL-61-SPS-1	CL-61-SSPS-1	3/8-16	4.5	18.5	5/8	.110	.186
CL-71-SPS-1	CL-71-SSPS-1	1/2-13	5	28	3/4	.151	.248
CL-81-SPS-1	—	5/8-11	7	50	1-1/16	.215	.310

DELRIN® PLUNGER NOSE, HEAVY FORCE (INCH)

PART NO.		A	INITIAL	FINAL	B	C	D DIA
STEEL	STAINLESS						
CL-21-SPN-1	—	#8-32	1.5	4.75	7/16	.052	.070
CL-22-SPN-1	—	#8-36					
CL-31-SPN-1	—	#10-32	1.75	6.25	15/32	.065	.093
CL-43-SPN-1	—	1/4-20	3	10.5	17/32	.078	.119
CL-51-SPN-1	—	5/16-18	3.75	15.5	9/16	.084	.135
CL-61-SPN-1	—	3/8-16	4.5	18.5	5/8	.110	.186
CL-71-SPN-1	—	1/2-13	5	28	3/4	.151	.248
CL-81-SPN-1	—	5/8-11	7	50	1-1/16	.215	.310

STANDARD PLUNGER NOSE, LIGHT FORCE (METRIC)

PART NO.		A	INITIAL	FINAL	B	C	D DIA
STEEL	STAINLESS						
CLM-51-SPS-1	—	M5	.7	2.5	.47	.065	.093
CLM-61-SPS-1	—	M6	1	3.5	.53	.078	.119
CLM-81-SPS-1	—	M8	1.5	4	.56	.084	.135
CLM-101-SPS-1	—	M10	1.5	5	.62	.110	.186
CLM-121-SPS-1	—	M12	1.8	5.5	.75	.151	.248

DELRIN® PLUNGER NOSE, LIGHT FORCE (METRIC)

PART NO.		A	INITIAL	FINAL	B	C	D DIA
STEEL	STAINLESS						
CLM-51-SPN-1	—	M5	.7	2.5	.47	.065	.093
CLM-61-SPN-1	—	M6	1	3.5	.53	.078	.119
CLM-81-SPN-1	—	M8	1.5	4	.56	.084	.135
CLM-101-SPN-1	—	M10	1.5	5	.62	.110	.186
CLM-121-SPN-1	—	M12	1.8	5.5	.75	.151	.248

STANDARD PLUNGER NOSE, HEAVY FORCE (METRIC)

PART NO.		A	INITIAL	FINAL	B	C	D DIA
STEEL	STAINLESS						
CLM-51-SPS-2	—	M5	1.8	6.3	.47	.065	.093
CLM-61-SPS-2	—	M6	3	10.5	.53	.078	.119
CLM-81-SPS-2	—	M8	3.8	15.5	.56	.084	.135
CLM-101-SPS-2	—	M10	4.5	18.5	.62	.110	.186
CLM-121-SPS-2	—	M12	5	28	.75	.151	.248

DELRIN® PLUNGER NOSE, HEAVY FORCE (METRIC)

PART NO.		A	INITIAL	FINAL	B	C	D DIA
STEEL	STAINLESS						
—	—	M5	1.8	6.3	.47	.065	.093
—	—	M6	3	10.5	.53	.078	.119
—	—	M8	3.8	15.5	.56	.084	.135
—	—	M10	4.5	18.5	.62	.110	.186
—	—	M12	5	28	.75	.151	.248

SHORT SPRING PLUNGERS WITH EXTENDED TRAVEL

STEEL – BODY: 1215 STEEL, BLACK OXIDE FINISH. PLUNGER NOSE: 1215 STEEL, CARBURIZED-HARDENED, BLACK OXIDE FINISH OR ZINC PLATED CLEAR CHROMATE (OR DELRIN®). SPRING: MUSIC WIRE
 STAINLESS STEEL – BODY: 300-SERIES STAINLESS.
 PLUNGER NOSE: 300-SERIES STAINLESS (OR DELRIN®). SPRING: 302 STAINLESS.



These Spring Plungers have the body length of a Short Spring Plunger while providing the longer stroke of a standard Spring Plunger (spring force is somewhat reduced). This self-contained plunger-and-spring device is available in a wide range of sizes. Locking element holds the unit securely in place after installation. Install and/or adjust from either end (when using the slot at the plunger end, install with a Plunger Wrench to avoid over-compressing the spring).

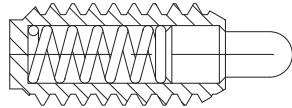

Nose Extended

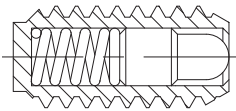

Nose Retracted

Available in thread sizes from #8-32 to 5/8-11 (M5 to M12 in metric). Available in steel, with a hardened plunger nose, or stainless steel. Optionally available with a Delrin® nose to prevent marring.

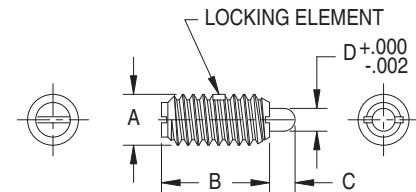

STANDARD PLUNGER NOSE (INCH)

PART NO.		A	END FORCE (LBS)		B	C	D DIA
STEEL	STAINLESS		INITIAL	FINAL			
CL-25-SPS-1	CL-25-SSPS-1	#8-32	1.0	3.2	7/16	.093	.070
CL-26-SPS-1	CL-26-SSPS-1	#8-36					
CL-35-SPS-1	CL-35-SSPS-1	#10-32	1.2	4.2	15/32	.125	.093
CL-45-SPS-1	CL-45-SSPS-1	1/4-20	2.0	7.0	17/32	.187	.119
CL-55-SPS-1	CL-55-SSPS-1	5/16-18	2.5	10.5	9/16	.187	.135
CL-65-SPS-1	CL-65-SSPS-1	3/8-16	3.0	12.5	5/8	.187	.186
CL-75-SPS-1	CL-75-SSPS-1	1/2-13	3.5	19	3/4	.250	.248
CL-85-SPS-1	—	5/8-11	4.5	34	1-1/16	.312	.310

DELRIN® PLUNGER NOSE (INCH)

PART NO.		A	END FORCE (LBS)		B	C	D DIA
STEEL	STAINLESS		INITIAL	FINAL			
—	—	#8-32	1.0	3.2	7/16	.093	.070
—	—	#8-36					
CL-35-SPN-1	—	#10-32	1.2	4.2	15/32	.125	.093
CL-45-SPN-1	—	1/4-20	2.0	7.0	17/32	.187	.119
—	—	5/16-18	2.5	10.5	9/16	.187	.135
CL-65-SPN-1	—	3/8-16	3.0	12.5	5/8	.187	.186
—	—	1/2-13	3.5	19	3/4	.250	.248
—	—	5/8-11	4.5	34	1-1/16	.312	.310

STANDARD PLUNGER NOSE (METRIC)

PART NO.		A	END FORCE (LBS)		B	C	D DIA
STEEL	STAINLESS		INITIAL	FINAL			
CLM-55-SPS-1	—	M5	1.2	4.2	.47	.125	.093
CLM-65-SPS-1	—	M6	2.0	7.0	.53	.187	.119
CLM-85-SPS-1	—	M8	2.5	10.5	.56	.187	.135
CLM-105-SPS-1	—	M10	3.0	12.5	.62	.187	.186
CLM-125-SPS-1	—	M12	3.5	19	.75	.250	.248

DELRIN® PLUNGER NOSE (METRIC)

PART NO.		A	END FORCE (LBS)		B	C	D DIA
STEEL	STAINLESS		INITIAL	FINAL			
—	—	M5	1.2	4.2	.47	.125	.093
CLM-65-SPN-1	—	M6	2.0	7.0	.53	.187	.119
CLM-85-SPN-1	—	M8	2.5	10.5	.56	.187	.135
—	—	M10	3.0	12.5	.62	.187	.186
—	—	M12	3.5	19	.75	.250	.248

PRESS-FIT SPRING PLUNGERS

STEEL – BODY: 1215 STEEL, BLACK OXIDE FINISH. PLUNGER NOSE: 1215 STEEL, CARBURIZED-HARDENED, BLACK OXIDE FINISH OR ZINC PLATED CLEAR CHROMATE (OR DELRIN®). SPRING: MUSIC WIRE.

STAINLESS STEEL – BODY: 300-SERIES STAINLESS. PLUNGER NOSE: 300-SERIES STAINLESS (OR DELRIN®). SPRING: 302 STAINLESS

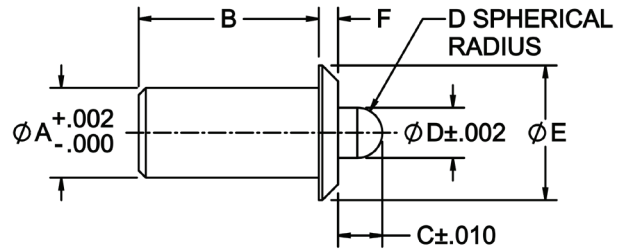

Simple, economical spring-loaded plunger ideal for installation in softer materials, such as aluminum, wood or plastic. Sturdy shoulder provides a fixed seating position and positively resists detent force (installation hole can be counterbored to recess the shoulder). Use when a threaded hole would be impractical and/or adjustment is not required. Choice of six sizes, each in light or heavy force. Available in steel, with a hardened plunger nose, or stainless steel. Optionally available with a Delrin® nose to prevent marring.

STANDARD PLUNGER NOSE, LIGHT FORCE

PART NO.	A DIA	INITIAL END FORCE (lbs)	FINAL END FORCE (lbs)	B	C	D	E DIA	F
CL-2-PSP-1	0.125	0.5	1	0.252	0.062	0.070	0.187	0.032
CL-3-PSP-1	0.188	0.8	2.5	0.441	0.094	0.121	0.250	0.044
CL-4-PSP-1	0.250	1.5	3	0.481	0.125	0.168	0.312	0.044
CL-5-PSP-1	0.312	2	5	0.643	0.151	0.186	0.375	0.045
CL-6-PSP-1	0.375	2.5	7	0.785	0.187	0.234	0.500	0.078
CL-8-PSP-1	0.500	4	9	1.13	0.250	0.332	0.688	0.088

STANDARD PLUNGER NOSE, HEAVY FORCE

CL-2-PSP-2	0.125	1	2	0.252	0.062	0.070	0.187	0.032
CL-3-PSP-2	0.188	1.5	4.5	0.441	0.094	0.121	0.250	0.044
CL-4-PSP-2	0.250	2.5	6	0.481	0.125	0.168	0.312	0.044
CL-5-PSP-2	0.312	4	10	0.643	0.151	0.186	0.375	0.045
CL-6-PSP-2	0.375	5	14	0.785	0.187	0.234	0.500	0.078
CL-8-PSP-2	0.500	8	18	1.130	0.250	0.332	0.688	0.088

DELRIN® PLUNGER NOSE, LIGHT FORCE

CL-2-PSPN-1	0.125	0.5	1	0.252	0.062	0.070	0.187	0.032
CL-3-PSPN-1	0.188	0.8	2.5	0.441	0.094	0.121	0.250	0.044
CL-4-PSPN-1	0.250	1.5	3	0.481	0.125	0.168	0.312	0.044
CL-5-PSPN-1	0.312	2	5	0.643	0.151	0.186	0.375	0.045
CL-6-PSPN-1	0.375	2.5	7	0.785	0.187	0.234	0.500	0.078
CL-8-PSPN-1	0.500	4	9	1.130	0.250	0.332	0.688	0.088

DELRIN® PLUNGER NOSE, HEAVY FORCE

CL-2-PSPN-2	0.125	1	2	0.252	0.062	0.070	0.187	0.032
CL-3-PSPN-2	0.188	1.5	4.5	0.441	0.094	0.121	0.250	0.044
CL-4-PSPN-2	0.250	2.5	6	0.481	0.125	0.168	0.312	0.044
CL-5-PSPN-2	0.312	4	10	0.643	0.151	0.186	0.375	0.045
CL-6-PSPN-2	0.375	5	14	0.785	0.187	0.234	0.500	0.078
CL-8-PSPN-2	0.500	8	18	1.130	0.250	0.332	0.688	0.088

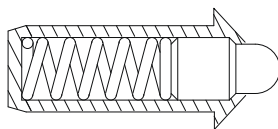

Nose Extended

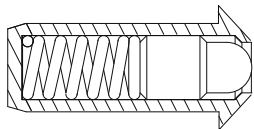

Nose Retracted

BALL PLUNGERS

TYPES



STANDARD, STEEL BALL

Self-contained ball-and-spring device available in many sizes and forces. Locking element holds the unit securely in place after installation. Install and/or adjust from either end.



STANDARD, DELRIN® BALL

Self-contained ball-and-spring device available in many sizes and forces. Locking element holds the unit securely in place after installation. Install and/or adjust from either end.



PRESS FIT

Simple, economical spring-loaded plunger ideal for installation in softer materials, such as aluminum, wood, or plastic. Sturdy shoulder provides a fixed seating position.



SELF-RETAINING

Due to their self-retaining design, these press-fit ball plungers can be securely installed in an ordinary drilled hole. The slotted end of the thermoplastic body expands to compensate for hole tolerances up to .008" oversize.

4

TECHNICAL INFORMATION

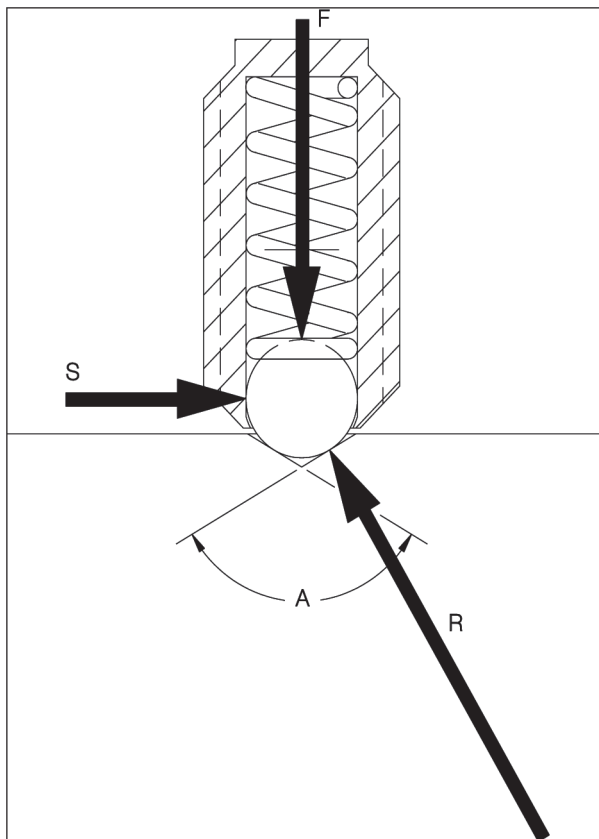

INSTALLATION:

To obtain full locking torque, countersink the installation hole to avoid cutting the locking element. Countersink at a 90-100° angle to a diameter 1/32" larger than the major thread diameter. Then, as you screw the plunger into its hole, the locking element will be compressed, not cut. **INFO+:** See page 171 for plunger wrenches.

BREAKAWAY FORCE:

To calculate the side force needed to slide a ball plunger out of its detent hole, refer to the free-body force diagram to the left. In the diagram, S= Side force, F= End force (spring force), R= Reaction force, and A= Countersink angle. The reaction force (R) is perpendicular to the contact surface. Solving for side force (S):

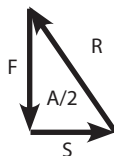

$$S = \frac{F}{\tan(A/2)}$$

End force (F) depends on how far the spring will be compressed, which depends on how far away from the sliding surface the ball plunger is installed. Maximum spring compression and end force occur as the ball breaks out of its hole.

BREAKAWAY-FORCE EXAMPLE:

A CL-40-BP-3 ball plunger (1/4-20) exerts an initial force of 4 lbs, a half-way force of 8 lbs, and a final force of 12 lbs. With a 90° countersink angle and half-way compression:

$$S = \frac{8 \text{ lbs}}{\tan(90^\circ/2)} = 8 \text{ lbs}$$

$$S = \frac{8 \text{ lbs}}{\tan(120^\circ/2)} = 4.6 \text{ lbs}$$

BALL PLUNGERS

SELECTION CHART:

STYLE	4-48	5-40	M3	6-40	8-32	M4	8-36	10-32	M6	1/4-20	M8	5/16-18	M10	3/8-16	M12	1/2-13	M16	5/8-11
Ball Plunger	X	X	X	X	X	X	X	X	X	X	X	X	X	X	X	X	X	X
Ball Plunger, Stainless Steel	X	X	X	X	X	X	X	X	X	X	X	X	X	X	X	X	X	X
Ball Plunger, Delrin® Body										X		X		X				
Ball Plunger, Delrin® Ball	X	X	X	X	X	X	X	X	X	X	X	X	X	X	X	X	X	X
Ball Plunger, Stainless Steel, Delrin® Ball	X	X	X	X	X	X	X	X	X	X	X	X	X	X	X	X	X	X
Ball Plunger, Delrin® Body, Delrin® Ball										X		X		X				
Press Fit Ball Plunger					1/8"			3/16"		1/4"		5/16"		3/8"		1/2"		
Press Fit Ball Plunger, Stainless Steel Ball					1/8"			3/16"		1/4"		5/16"		3/8"		1/2"		
Press Fit Ball Plunger, Delrin® Ball					1/8"			3/16"		1/4"		5/16"		3/8"		1/2"		
Press Fit Ball Plunger, Stainless Steel, Delrin® Ball					1/8"			3/16"		1/4"		5/16"		3/8"		1/2"		
Self-Retaining Stainless Steel Ball								3/16"		1/4"				3/8"		1/2"		

New Self-Retaining Ball Plungers

The slotted end of the thermoplastic body expands to compensate for hole tolerances up to .008".

Due to their self-retaining design, these press-fit ball plungers can be securely installed in an ordinary drilled hole.

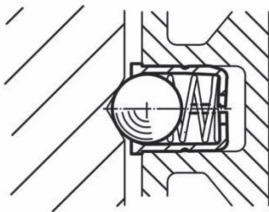

These plungers can be installed in a plain hole, with the shoulder exposed, or slightly counterbored for flush installation.

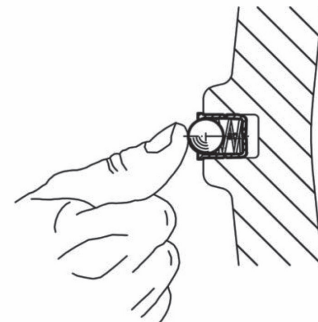

Self-Retaining Ball Plungers can often be installed by hand, due to the body's flexible design.

See Page 175

BALL DETENTS

440C STAINLESS STEEL, HEAT TREATED

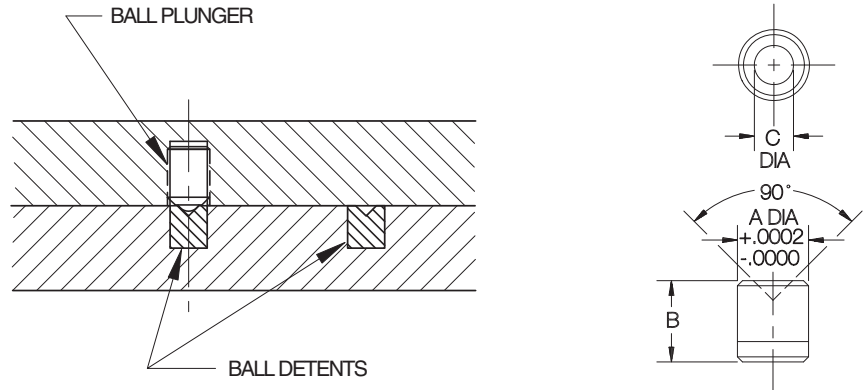

Press-in receptacle that provides a perfect mating hole for a Ball Plunger. Hole has a 90° point for smooth detent action and reliable retention. These hardened Ball Detents resist side loads to prevent wear to the parent material. Available in sizes to fit all Ball Plungers, from #4-48 to 5/8-11 (M4 to M12 in metric).

PART NO.	FOR BALL PLUNGER	A DIA	B	C DIA
CL-1-BD	#4-48, #5-40, M3	.1075	1/8	.056
CL-2-BD	#6-40	.1175	1/8	.061
CL-3-BD	#8-32, #8-36, #10-32, M4, M5	.1614	3/16	.082
CL-4-BD	1/4-20, M6	.2034	1/4	.111
CL-5-BD	5/16-18, M8	.2659	5/16	.139
CL-6-BD	3/8-16, M10	.3284	3/8	.164
CL-8-BD	1/2-13, M12	.4378	1/2	.241
CL-10-BD	5/8-11, M16	.5472	5/8	.330

4

PLUNGER WRENCHES

STEEL

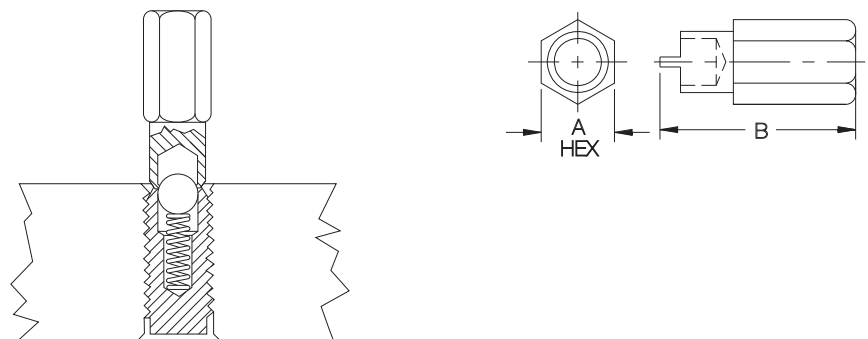

Handy tool to speed up installation of Ball Plungers or Spring Plungers. Much better than using a screwdriver on the ball/nose end, because the clearance hole in the center prevents over-compressing the plunger's internal spring. Available in sizes to fit all Ball Plungers and Spring Plungers, from #4-48 to 1"-8 (M4 to M12 in metric).

PART NO.	FITS THESE PLUNGER SIZES	A	B
CL-2-SPW	#4-48, #5-40, #6-32, #6-40	1/4	7/8
CL-4-SPW	#8-32, #8-36, M4	1/4	7/8
CL-6-SPW	#10-32, M5	1/4	7/8
CL-8-SPW	1/4-20, 1/4-28, M6	1/4	1
CL-10-SPW	5/16-18, M8	3/8	1
CL-12-SPW	3/8-16, M10	3/8	1
CL-14-SPW	1/2-13, M12	1/2	1
CL-16-SPW	5/8-11	5/8	1-1/8
CL-18-SPW	3/4-10	3/4	1-1/8
CL-20-SPW	1"-8	7/8	1-3/8

BALL PLUNGERS

STEEL – BODY: 1215 STEEL, ZINC PLATED OR BLACK OXIDE FINISH.

BALL: 440C STAINLESS. SPRING: MUSIC WIRE

STAINLESS STEEL – BODY: 300-SERIES STAINLESS. BALL: 440C STAINLESS. SPRING: 302 STAINLESS.

DELRIN® – BODY: DELRIN® 500, WHITE, BLACK, OR YELLOW. BALL: 440C STAINLESS. SPRING: 302 STAINLESS

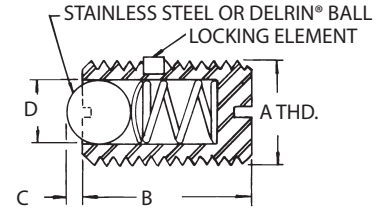
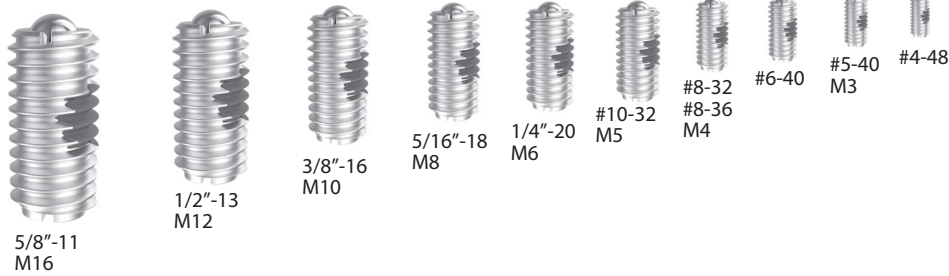

4

STANDARD BALL (INCH)

PART NO.			A	END FORCE (LBS)		B	C	D DIA
STEEL BODY	STAINLESS BODY	DELRIN® BODY		INITIAL	FINAL			
CL-5-BP-1	CL-5-SBP-1	—	#4-48	1/8	1/2	3/16	.020	.062
CL-10-BP-1	CL-10-SBP-1	—	#5-40	1/4	3/4	1/4	.023	.078
CL-15-BP-1	CL-15-SBP-1	—	#6-40	1/2	1	5/16	.025	.093
CL-22-BP-1	CL-22-SBP-1	—	#8-32	1/2	1-1/4	11/32	.025	.093
CL-20-BP-1	CL-20-SBP-1	—	#8-36	1/2	1-1/2	11/32	.025	.093
CL-30-BP-1	CL-30-SBP-1	—	#10-32	1/2	1-1/2	33/64	.025	.093
CL-30-BP-2	CL-30-SBP-2	—		1-1/2	3			
CL-30-BP-3	CL-30-SBP-3	—		2	5			
CL-40-BP-1	CL-40-SBP-1	CL-40-DBP-1-LL	1/4-20	2	4	17/32	.035	.125
CL-40-BP-2	CL-40-SBP-2	CL-40-DBP-2-LL		3	7			
CL-40-BP-3	CL-40-SBP-3	CL-40-DBP-3-LL		4	12			
CL-50-BP-1	CL-50-SBP-1	CL-50-DBP-1-LL	5/16-18	2	4-1/2	37/64	.040	.156
CL-50-BP-2	CL-50-SBP-2	CL-50-DBP-2-LL		4	9			
CL-50-BP-3	CL-50-SBP-3	CL-50-DBP-3-LL		6	17			
CL-60-BP-1	CL-60-SBP-1	CL-60-DBP-1-LL	3/8-16	2-1/2	5	5/8	.048	.187
CL-60-BP-2	CL-60-SBP-2	CL-60-DBP-2-LL		5	10			
CL-60-BP-3	CL-60-SBP-3	CL-60-DBP-3-LL		6	21			
CL-70-BP-1	CL-70-SBP-1	—	1/2-13	3	6	3/4	.072	.281
CL-70-BP-2	CL-70-SBP-2	—		6	12			
CL-70-BP-3	CL-70-SBP-3	—		6	30			
CL-80-BP-1	CL-80-SBP-1	—	5/8-11	4-1/2	9	63/64	.096	.375
CL-80-BP-2	CL-80-SBP-2	—		9	18			
CL-80-BP-3	CL-80-SBP-3	—		7	50			

STANDARD BALL (METRIC)

PART NO. STAINLESS STEEL BODY	PART NO. STEEL BODY	A THREAD	THREAD PITCH (mm)	END FORCE	INITIAL END FORCE (N)	FINAL END FORCE (N)	B (mm)	C (mm)	D DIA (mm)
CLM-3-SBP-1	—	M3	.5	Light	.5	2.2	4.7	.5	1.6
CLM-4-SBP-1	CLM-4-BP-1	M4	.7	Light	2.5	5	8.5	.6	2.4
CLM-5-SBP-2	CLM-5-BP-2	M5	.8	Light	2.2	65	13	.6	2.4
CLM-5-SBP-1	CLM-5-BP-1	M5	.8	Medium	6.5	13	13	.6	2.4
CLM-5-SBP-3	CLM-5-BP-3	M5	.8	Heavy	9	22	13	.6	2.4
CLM-6-SBP-2	CLM-6-BP-2	M6	1	Light	9	18	13.5	.9	3.2
CLM-6-SBP-1	CLM-6-BP-1	M6	1	Medium	13	31	13.5	.9	3.2
CLM-6-SBP-3	CLM-6-BP-3	M6	1	Heavy	18	53	13.5	.9	3.2
CLM-8-SBP-2	CLM-8-BP-2	M8	1.25	Light	10	19.5	14.5	1	4
CLM-8-SBP-1	CLM-8-BP-1	M8	1.25	Medium	17.5	39	14.5	1	4
CLM-8-SBP-3	CLM-8-BP-3	M8	1.25	Heavy	27	76	14.5	1	4
CLM-10-SBP-2	CLM-10-BP-2	M10	1.5	Light	11	22	16	1.2	4.8
CLM-10-SBP-1	CLM-10-BP-1	M10	1.5	Medium	22	44	16	1.2	4.8
CLM-10-SBP-3	CLM-10-BP-3	M10	1.5	Heavy	27	93	16	1.2	4.8
CLM-12-SBP-2	CLM-12-BP-2	M12	1.75	Light	13.5	27	19	2	7.1
CLM-12-SBP-1	CLM-12-BP-1	M12	1.75	Medium	27	54	19	2	7.1
CLM-12-SBP-3	CLM-12-BP-3	M12	1.75	Heavy	27	132	19	2	7.1
CLM-16-SBP-2	CLM-16-BP-2	M16	2	Light	20	40	25	2.5	9.5
CLM-16-SBP-1	CLM-16-BP-1	M16	2	Medium	40	80	25	2.5	9.5
CLM-16-SBP-3	CLM-16-BP-3	M16	2	Heavy	31	220	25	2.5	9.5

BALL PLUNGERS

STAINLESS STEEL – BODY: 300-SERIES STAINLESS. BALL: WHITE DELRIN® 500. SPRING: 302 STAINLESS.
 DELRIN® – BODY: DELRIN® 500, BLACK, OR YELLOW. BALL: WHITE DELRIN® 500. SPRING: 302 STAINLESS.

Self-contained ball-and-spring device available in many sizes and forces. Available in thread sizes from #4-48 to 5/8-11 (M3 to M16 in metric). Choice of light, medium, or heavy force in most thread sizes. Available in steel, stainless steel or Delrin®, all with a 440C stainless steel ball (optionally available with a Delrin® ball). Locking element (steel and stainless only) holds the unit securely in place after installation. Install and/or adjust from either end (when using the slot at the ball end, install with a Plunger Wrench to avoid over-compressing the spring). The three smallest sizes, and all Delrin® sizes, have no slot at the ball end.

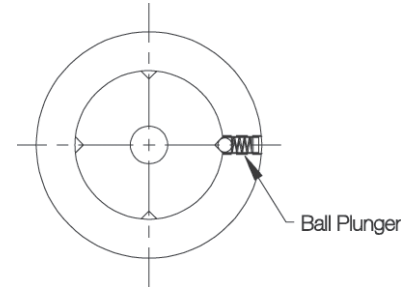

DELRIN® BALL (INCH)

PART NO.		A	END FORCE (LBS)		B	C	D DIA
STAINLESS BODY	DELRIN® BODY		INITIAL	FINAL			
CL-5-SBPN-1	—	#4-48	1/8	1/2	3/16	.020	.062
CL-10-SBPN-1	—	#5-40	1/4	3/4	1/4		
CL-15-SBPN-1	—	#6-40	1/2	1	5/16	.023	.078
CL-22-SBPN-1	—	#8-32	1/2	1-1/4	11/32	.025	.093
CL-20-SBPN-1	—	#8-36					
CL-30-SBPN-1	—	#10-32	1/2	1-1/2	33/64	.025	.093
CL-30-SBPN-2	—		1-1/2	3			
CL-30-SBPN-3	—		2	5			
CL-40-SBPN-1	CL-40-DBPN-1-LL	1/4-20	2	4	17/32	.035	.125
CL-40-SBPN-2	CL-40-DBPN-2-LL		3	7			
CL-40-SBPN-3	—		4	12			
CL-50-SBPN-1	CL-50-DBPN-1-LL	5/16-18	2	4-1/2	37/64	.040	.156
CL-50-SBPN-2	CL-50-DBPN-2-LL		4	9			
CL-50-SBPN-3	—		6	17			
CL-60-SBPN-1	CL-60-DBPN-1-LL	3/8-16	2-1/2	5	5/8	.048	.187
CL-60-SBPN-2	CL-60-DBPN-2-LL		5	10			
CL-60-SBPN-3	—		6	21			
CL-70-SBPN-1	—	1/2-13	3	6	3/4	.072	.281
CL-70-SBPN-2	—		6	12			
CL-70-SBPN-3	—		6	30			
CL-80-SBPN-1	—	5/8-11	4-1/2	9	63/64	.096	.375
CL-80-SBPN-2	—		9	18			
CL-80-SBPN-3	—		7	50			

DELRIN® BALL (METRIC)

PART NO.	A THREAD	THREAD PITCH (mm)	END FORCE	INITIAL END FORCE (N)	FINAL END FORCE (N)	B (mm)	C (mm)	D DIA (mm)
CLM-3-SBPN-1	M3	.5	Light	.5	2.2	4.7	.5	1.6
CLM-4-SBPN-1	M4	.7	Light	2.5	5	8.5	.6	2.4
CLM-5-SBPN-2	M5	.8	Light	2.2	6.5	13	.6	2.4
CLM-5-SBPN-1	M5	.8	Medium	6.5	13	13	.6	2.4
CLM-6-SBPN-2	M6	1	Light	9	18	13.5	.9	3.2
CLM-6-SBPN-1	M6	1	Medium	13	31	13.5	.9	3.2
CLM-8-SBPN-2	M8	1.25	Light	10	19.5	14.5	1	4
CLM-8-SBPN-1	M8	1.25	Medium	17.5	39	14.5	1	4
CLM-10-SBPN-2	M10	1.5	Light	11	22	16	1.2	4.8
CLM-10-SBPN-1	M10	1.5	Medium	22	44	16	1.2	4.8
CLM-12-SBPN-2	M12	1.75	Light	13.5	27	19	2	7.1
CLM-12-SBPN-1	M12	1.75	Medium	27	54	19	2	7.1
CLM-16-SBPN-2	M16	2	Light	20	40	25	2.5	9.5
CLM-16-SBPN-1	M16	2	Medium	40	80	25	2.5	9.5

PRESS-FIT BALL PLUNGERS

STEEL – BODY: 1215 STEEL, BLACK OXIDE FINISH. BALL: 440C STAINLESS (OR DELRIN®). SPRING: MUSIC WIRE
 STAINLESS STEEL – BODY: 300-SERIES STAINLESS. BALL: 440C STAINLESS (OR DELRIN®). SPRING: 302 STAINLESS

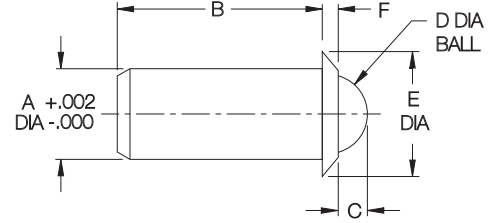

4

Simple, economical ball plunger ideal for installation in softer materials, such as aluminum, wood or plastic. Sturdy shoulder provides a fixed seating position and positively resists detent force (installation hole can be counterbored to recess the shoulder). Use when a threaded hole would be impractical and/or adjustment is not required. Available in steel or stainless steel. Choice of six sizes, each in light or heavy force, with a stainless steel or Delrin® ball.

STANDARD BALL, LIGHT FORCE

PART NO.		A DIA	END FORCE (LBS)		B	C	D DIA	E DIA	F
STEEL	STAINLESS		INITIAL	FINAL					
CL-2-PBP-1	CL-2-PBPS-1	.125	.5	1	.252	.035	.093	.187	.032
CL-3-PBP-1	CL-3-PBPS-1	.188	1	2.5	.405	.058	.156	.250	.035
CL-4-PBP-1	CL-4-PBPS-1	.250	1.5	3.5	.481	.070	.188	.312	.044
CL-5-PBP-1	CL-5-PBPS-1	.312	2	5	.643	.090	.250	.375	.045
CL-6-PBP-1	CL-6-PBPS-1	.375	2.5	7	.785	.110	.312	.500	.078
CL-8-PBP-1	CL-8-PBPS-1	.500	4	9	1.130	.161	.438	.688	.088

STANDARD BALL, HEAVY FORCE

PART NO.		A DIA	END FORCE (LBS)		B	C	D DIA	E DIA	F
STEEL	STAINLESS		INITIAL	FINAL					
CL-2-PBP-2	CL-2-PBPS-2	.125	.75	2.5	.252	.035	.093	.187	.032
CL-3-PBP-2	CL-3-PBPS-2	.188	2	5	.405	.058	.156	.250	.035
CL-4-PBP-2	CL-4-PBPS-2	.250	3	7	.481	.070	.188	.312	.044
CL-5-PBP-2	CL-5-PBPS-2	.312	4	10	.643	.090	.250	.375	.045
CL-6-PBP-2	CL-6-PBPS-2	.375	5	14	.785	.110	.312	.500	.078
CL-8-PBP-2	CL-8-PBPS-2	.500	8	18	1.130	.161	.438	.688	.088

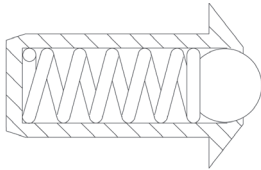

DELRIN® BALL, LIGHT FORCE

PART NO.		A DIA	END FORCE (LBS)		B	C	D DIA	E DIA	F
STEEL	STAINLESS		INITIAL	FINAL					
CL-2-PBPN-1	CL-2-PBPSN-1	.125	.5	1	.252	.035	.093	.187	.032
CL-3-PBPN-1	CL-3-PBPSN-1	.188	1	2.5	.405	.058	.156	.250	.035
CL-4-PBPN-1	CL-4-PBPSN-1	.250	1.5	3.5	.481	.070	.188	.312	.044
CL-5-PBPN-1	CL-5-PBPSN-1	.312	2	5	.643	.090	.250	.375	.045
CL-6-PBPN-1	CL-6-PBPSN-1	.375	2.5	7	.785	.110	.312	.500	.078
CL-8-PBPN-1	CL-8-PBPSN-1	.500	4	9	1.130	.161	.438	.688	.088

DELRIN® BALL, HEAVY FORCE

PART NO.		A DIA	END FORCE (LBS)		B	C	D DIA	E DIA	F
STEEL	STAINLESS		INITIAL	FINAL					
CL-2-PBPN-2	CL-2-PBPSN-2	.125	.75	2.5	.252	.035	.093	.187	.032
CL-3-PBPN-2	CL-3-PBPSN-2	.188	2	5	.405	.058	.156	.250	.035
CL-4-PBPN-2	CL-4-PBPSN-2	.250	3	7	.481	.070	.188	.312	.044
CL-5-PBPN-2	CL-5-PBPSN-2	.312	4	10	.643	.090	.250	.375	.045
CL-6-PBPN-2	CL-6-PBPSN-2	.375	5	14	.785	.110	.312	.500	.078
CL-8-PBPN-2	CL-8-PBPSN-2	.500	8	18	1.130	.161	.438	.688	.088

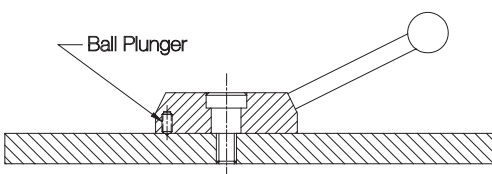

SELF-RETAINING BALL PLUNGERS

BODY: BLACK THERMOPLASTIC (POM)
 BALL: STAINLESS STEEL, HARDENED
 SPRING: STAINLESS STEEL



Due to their self-retaining design, these press-fit ball plungers can be securely installed in an ordinary drilled hole. The slotted end of the thermoplastic body expands to compensate for hole tolerances up to .008" oversize. Sturdy shoulder provides a fixed seating position and positively resists detent force. Installation hole can be counterbored to recess the shoulder.

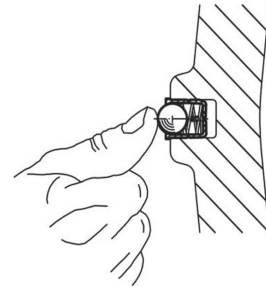

4

Self-Retaining Ball Plungers can often be installed by hand, due to the body's flexible design.

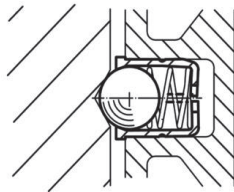

These plungers can be installed in a plain hole, with the shoulder exposed, or slightly counterbored for flush installation.

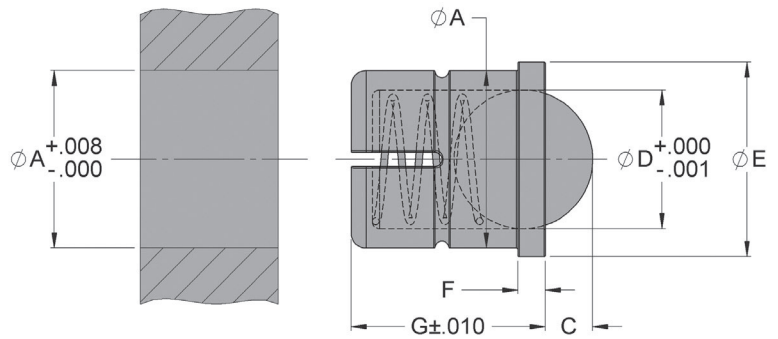

INCH

PART NO.	A DIA	END FORCE (LBS)		C	D DIA	E DIA	F	G
		INITIAL	FINAL					
CL-3-SRBP-1	.188	1.3	2.1	.039	.157	.220	.039	.236
CL-4-SRBP-1	.250	1.4	2.8	.059	.197	.276	.039	.276
CL-6-SRBP-1	.375	2.7	5.0	.091	.315	.433	.059	.531
CL-8-SRBP-1	.500	3.1	5.6	.126	.394	.551	.059	.630

HAND-RETRACTABLE PLUNGERS

STEEL: 1215 BODY, 1215 PLUNGER CARBURIZED-HARDENED (OR DELRIN®, 17-7PH SPRING).
 ALL STEEL COMPONENTS ZINC PLATED CLEAR CHROMATE.
 STAINLESS STEEL: 300 SERIES

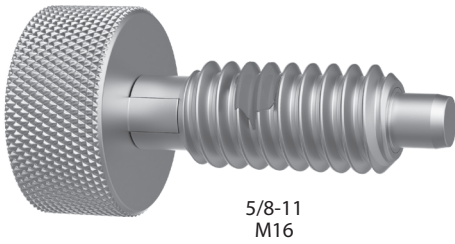

5/8-11
M16

Spring-loaded plunger that locks in retracted position. To lock, pull knurled knob back and turn 90°. Standard plunger has a slight taper on plunger tip for easy alignment. Also available with a radiused Delrin® plunger (slightly larger diameter and lighter spring force). Available in steel or stainless steel.

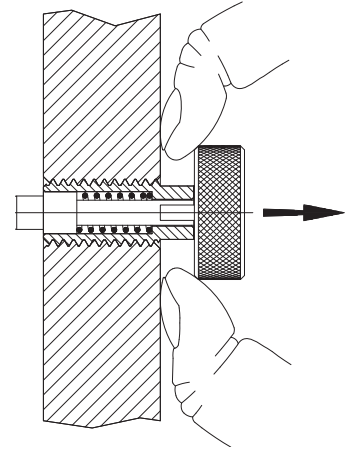

Pull knob to retract...

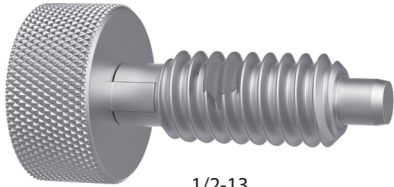

1/2-13
M12

Knurled Head (Locking Type)

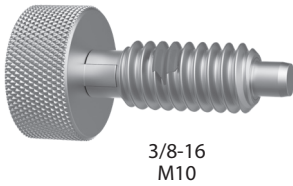

3/8-16
M10

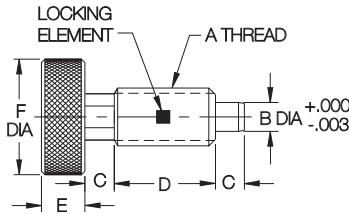

Standard Plunger

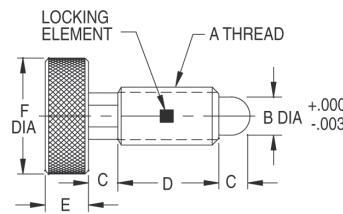

Radiused Delrin® Plunger

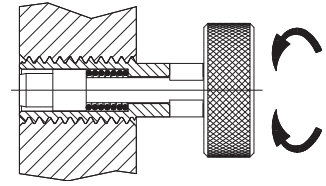

...then turn 90° in either direction to lock.

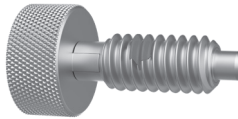

5/16-18
M8

KNURLED HEAD — STEEL (INCH)

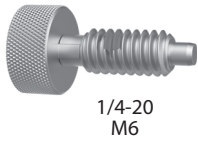

1/4-20
M6

PART NO. STANDARD PLUNGER	PART NO. RADIUSED DELRIN PLUNGER	A	STANDARD PLUNGER				RADIUSED DELRIN® PLUNGER				C	D	E	F DIA
			END FORCE (LBS)		B DIA		END FORCE (LBS)		B DIA					
			INITIAL	FINAL	NOMINAL	ACTUAL	INITIAL	FINAL	NOMINAL	ACTUAL				
CL-3-HRP	—	#10-32	1	3.5	7/64	.105	—	—	—	—	3/32	13/32	3/16	3/8
CL-4-HRP	CL-4-HRPN	1/4-20	1	5	1/8	.125	.5	2.5	5/32	.145	1/8	1/2	1/4	1/2
CL-5-HRP	CL-5-HRPN	5/16-18	1.5	6	5/32	.156	.7	3	3/16	.180	3/16	5/8	9/32	5/8
CL-6-HRP	CL-6-HRPN	3/8-16	1.5	8	3/16	.187	.7	4	7/32	.217	7/32	3/4	5/16	3/4
CL-8-HRP	CL-8-HRPN	1/2-13	2.5	10	1/4	.250	1.2	5	5/16	.311	1/4	7/8	3/8	1
CL-10-HRP	CL-10-HRPN	5/8-11	5	10	5/16	.312	3	6	3/8	.374	5/16	1	3/8	1-1/8

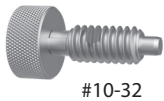

#10-32

KNURLED HEAD — STAINLESS (INCH)

PART NO. STANDARD PLUNGER	PART NO. RADIUSED DELRIN PLUNGER	A	STANDARD PLUNGER				RADIUSED DELRIN® PLUNGER				C	D	E	F DIA
			END FORCE (LBS)		B DIA		END FORCE (LBS)		B DIA					
			INITIAL	FINAL	NOMINAL	ACTUAL	INITIAL	FINAL	NOMINAL	ACTUAL				
CL-3-HRP-S	—	#10-32	1	3.5	7/64	.105	—	—	—	—	3/32	13/32	3/16	3/8
CL-4-HRP-S	CL-4-HRPN-S	1/4-20	1	5	1/8	.125	.5	2.5	5/32	.145	1/8	1/2	1/4	1/2
CL-5-HRP-S	CL-5-HRPN-S	5/16-18	1.5	6	5/32	.156	.7	3	3/16	.180	3/16	5/8	9/32	5/8
CL-6-HRP-S	CL-6-HRPN-S	3/8-16	1.5	8	3/16	.187	.7	4	7/32	.217	7/32	3/4	5/16	3/4
CL-8-HRP-S	CL-8-HRPN-S	1/2-13	2.5	10	1/4	.250	1.2	5	5/16	.311	1/4	7/8	3/8	1
CL-10-HRP-S	CL-10-HRPN-S	5/8-11	5	10	5/16	.312	3	6	3/8	.374	5/16	1	3/8	1-1/8

KNURLED HEAD — STEEL (METRIC)

PART NO. STANDARD PLUNGER	PART NO. RADIUSED DELRIN PLUNGER	A THREAD	THREAD PITCH (mm)	INITIAL END FORCE (N)	FINAL END FORCE (N)	B DIA (mm)	C (mm)	D (mm)	E (mm)	F DIA (mm)
CLM-6-HRP	—	M6	1	4	22	3	3.2	12.5	6.5	12.5
CLM-8-HRP	—	M8	1.25	7	27	4	4.8	16	7	16
CLM-10-HRP	—	M10	1.5	7	36	5	5.5	19	8	19
CLM-12-HRP	—	M12	1.75	11	44	6	6.5	22	9.5	25.5
CLM-16-HRP	—	M16	2	22	44	8	8	25.5	9.5	28.5

KNURLED HEAD — STAINLESS (METRIC)

PART NO. STANDARD PLUNGER	PART NO. RADIUSED DELRIN PLUNGER	A THREAD	THREAD PITCH (mm)	INITIAL END FORCE (N)	FINAL END FORCE (N)	B DIA (mm)	C (mm)	D (mm)	E (mm)	F DIA (mm)
CLM-6-HRP-S	—	M6	1	4	22	3	3.2	12.5	6.5	12.5
CLM-8-HRP-S	—	M8	1.25	7	27	4	4.8	16	7	16
CLM-10-HRP-S	—	M10	1.5	7	36	5	5.5	19	8	19
CLM-12-HRP-S	—	M12	1.75	11	44	6	6.5	22	9.5	25.5
CLM-16-HRP-S	—	M16	2	22	44	8	8	25.5	9.5	28.5

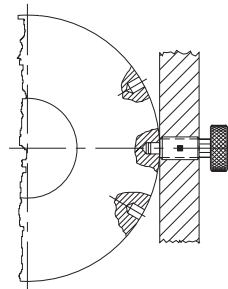

HAND-RETRACTABLE PLUNGERS

STEEL: 1215 BODY, 1215 PLUNGER CARBURIZED-HARDENED, 17-7PH SPRING.
 ALL STEEL COMPONENTS ZINC PLATED CLEAR CHROMATE.
 STAINLESS STEEL: 300 SERIES

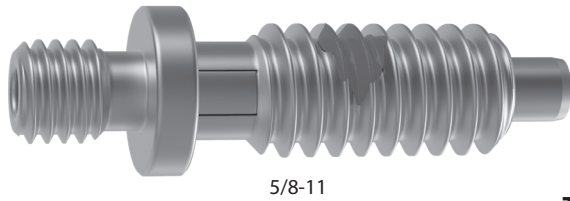

5/8-11

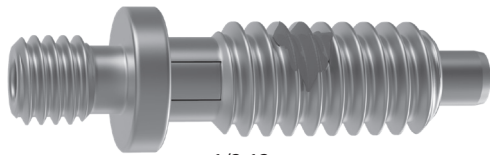

1/2-13
M12

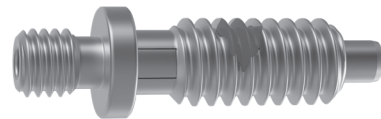

3/8-16
M10

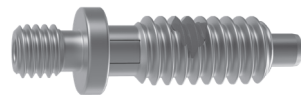

5/16-18
M8



1/4-20
M6



#10-32

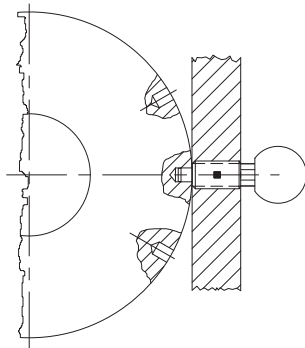

Threaded Stud for Knob Handle (Locking Type)

Spring-loaded plunger that locks in retracted position. To lock, pull knob back and turn 90°. Slight taper on plunger tip for easy alignment. Available in steel or stainless steel. The threaded-stud version shown here accepts virtually any type of knob handle. Knob handles can be permanently secured with thread-locking adhesive if desired.

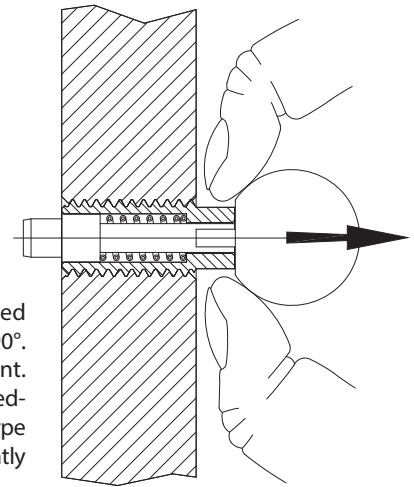

Pull knob to retract...

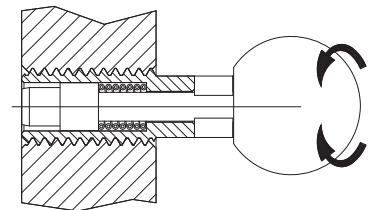

... then turn 90° in either direction to lock.

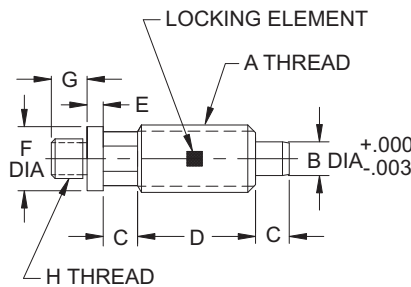

THREADED STUD FOR KNOB HANDLE — STEEL (INCH)

PART NO.	A	END FORCE (LBS)		B DIA		C	D	E	F DIA	G	H
		INITIAL	FINAL	NOMINAL	ACTUAL						
CL-3-HRPT	#10-32	1	3	—	.105	3/32	13/32	5/64	5/16	15/64	#10-32
CL-4-HRPT	1/4-20	1	5	1/8	.125	1/8	1/2	3/32	5/16	15/64	#10-32
CL-5-HRPT	5/16-18	1.5	6	5/32	.156	3/16	5/8	3/32	5/16	11/32	1/4-20
CL-6-HRPT	3/8-16	1.5	8	3/16	.187	7/32	3/4	1/8	3/8	13/32	5/16-18
CL-8-HRPT	1/2-13	2.5	10	1/4	.250	1/4	7/8	1/8	1/2	7/16	3/8-16
CL-10-HRPT	5/8-11	5	10	5/16	.312	5/16	1	5/32	5/8	1/2	1/2-13

THREADED STUD FOR KNOB HANDLE — STAINLESS STEEL (INCH)

CL-3-HRPT-S	#10-32	1	3.5	7/64	.105	3/32	13/32	5/64	5/16	15/64	#10-32
CL-4-HRPT-S	1/4-20	1	5	1/8	.125	1/8	1/2	3/32	5/16	15/64	#10-32
CL-5-HRPT-S	5/16-18	1.5	6	5/32	.156	3/16	5/8	3/32	5/16	11/32	1/4-20
CL-6-HRPT-S	3/8-16	1.5	8	3/16	.187	7/32	3/4	1/8	3/8	13/32	5/16-18
CL-8-HRPT-S	1/2-13	2.5	10	1/4	.250	1/4	7/8	1/8	1/2	7/16	3/8-16
CL-10-HRPT-S	5/8-11	5	10	5/16	.312	5/16	1	5/32	5/8	1/2	1/2-13

THREADED STUD FOR KNOB HANDLE — STEEL (METRIC)

A THREAD	THREAD PITCH (mm)	INITIAL END FORCE (N)	FINAL END FORCE (N)	B DIA (mm)	C (mm)	D (mm)	E (mm)	F DIA (mm)	G (mm)	H THREAD
CLM-6-HRPT	M6	1	4	22	3	3.2	12.5	2.4	8	6
CLM-8-HRPT	M8	1.25	7	27	4	4.8	16	2.4	8	8.5
CLM-10-HRPT	M10	1.5	7	36	5	5.5	19	3.2	9.5	10.5
CLM-12-HRPT	M12	1.75	11	44	6	6.5	22	3.2	12.5	11

HAND-RETRACTABLE PLUNGERS

STEEL: 1215 BODY, 1215 PLUNGER CARBURIZED-HARDENED, 17-7PH SPRING
 ALL STEEL COMPONENTS ZINC PLATED CLEAR CHROMATE
 STAINLESS STEEL: 300 SERIES

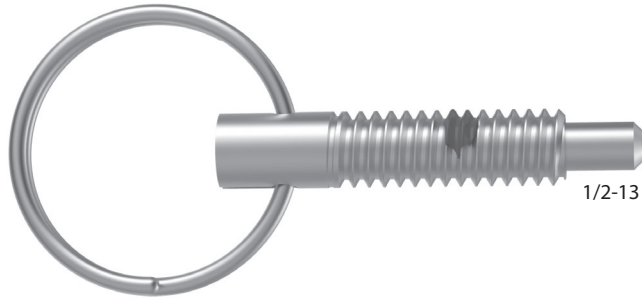

1/2-13

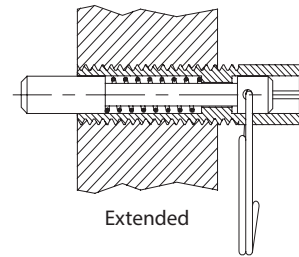

Extended

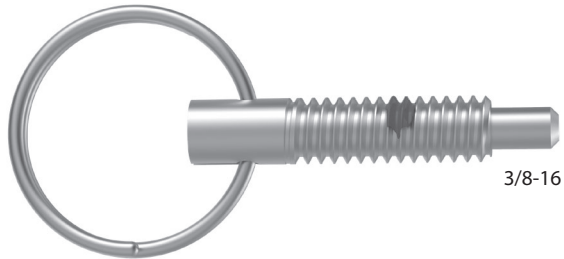

3/8-16

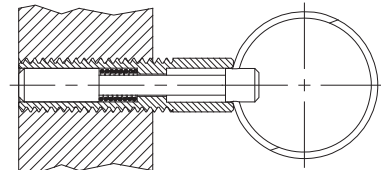

Retracted

**Pull Ring
(Locking Type)**

Spring-loaded plunger that can be withdrawn completely into the body and locked in retracted position. Comfortable pull ring allows quick actuation, yet stays out of the way when not in use.

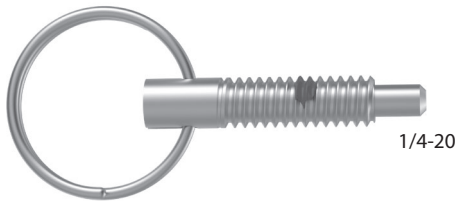

1/4-20

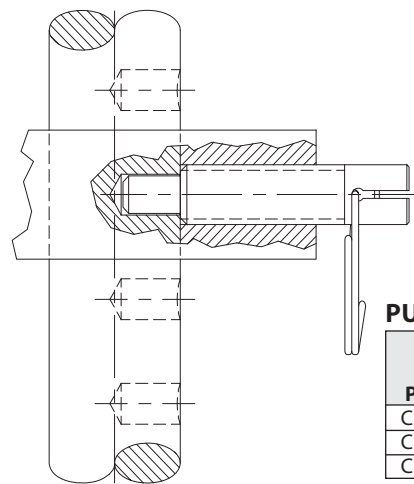
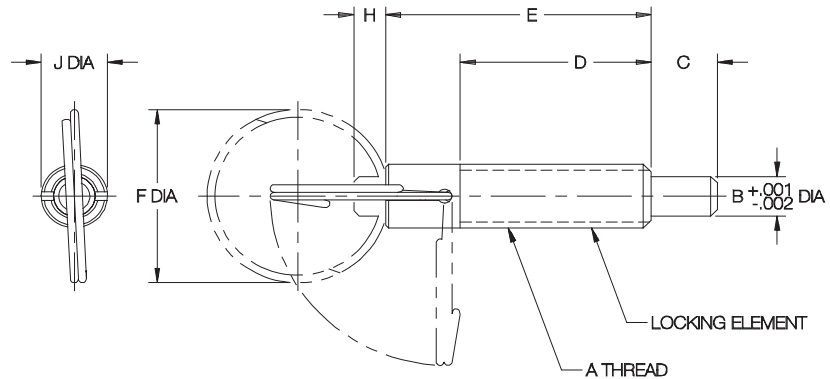

PULL RING, LOCKING TYPE — STEEL (INCH)

PART NO.	A	END FORCE (LBS)		B DIA	C	D	E	F DIA	H	J DIA
		INITIAL	FINAL							
CL-4-PHRP	1/4-20	1	2.5	.156	1/4	13/16	1-1/8	1	7/64	1/4
CL-6-PHRP	3/8-16	2	4	.250	3/8	1-1/4	1-11/16	1-1/4	3/16	3/8
CL-8-PHRP	1/2-13	2.5	5	.312	1/2	1-7/16	2	1-3/8	1/4	1/2

PULL RING, LOCKING TYPE — STAINLESS STEEL (INCH)

PART NO.	A	END FORCE (LBS)		B DIA	C	D	E	F DIA	H	J DIA
		INITIAL	FINAL							
CL-4-PHRP-S	1/4-20	1	2.5	.156	1/4	13/16	1-1/8	1	7/64	1/4
CL-6-PHRP-S	3/8-16	2	4	.250	3/8	1-1/4	1-11/16	1-1/4	3/16	3/8
CL-8-PHRP-S	1/2-13	2.5	5	.312	1/2	1-7/16	2	1-3/8	1/4	1/2

HAND-RETRACTABLE PLUNGERS

STEEL: 1215 BODY, 1215 PLUNGER CARBURIZED-HARDENED, 17-7PH SPRING
 ALL STEEL COMPONENTS ZINC PLATED CLEAR CHROMATE
 STAINLESS STEEL: 300 SERIES

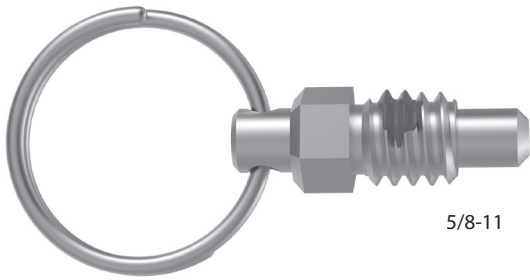

5/8-11

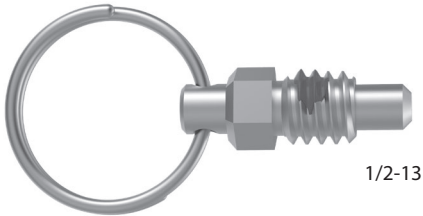

1/2-13

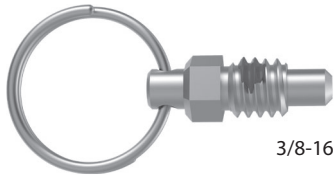

3/8-16

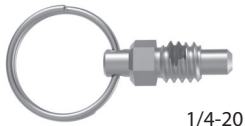

1/4-20

Extremely compact spring-loaded plunger that extends unless manually held in retracted position. Comfortable pull ring allows quick actuation, yet stays out of the way when not in use.

Pull Ring (Non-Locking Type)

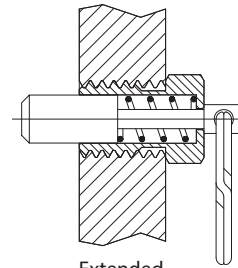

Extended

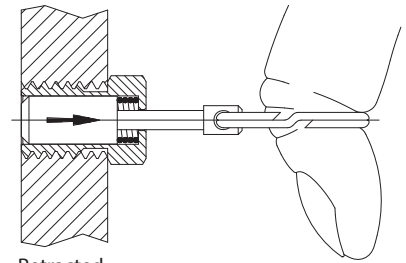

Retracted

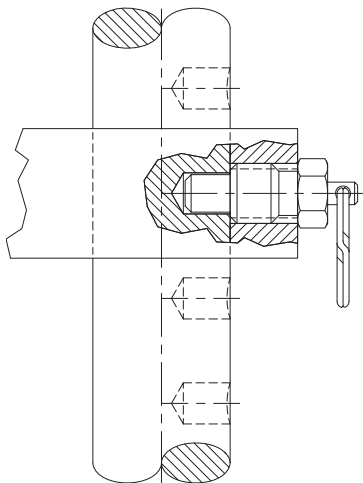
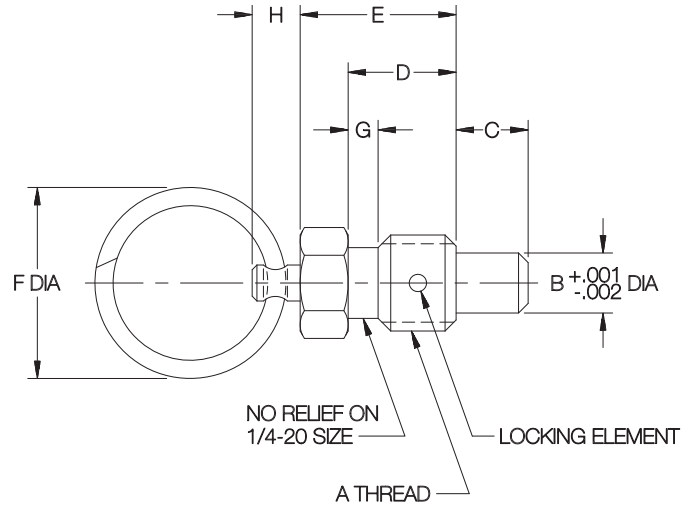
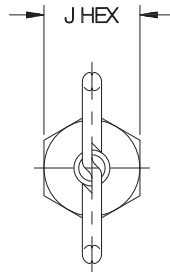

PULL RING, NON-LOCKING TYPE — STEEL (INCH)

PART NO.	A	END FORCE (LBS)		B DIA	C	D	E	F DIA	G	H	J
		INITIAL	FINAL								
CL-4-RHRP	1/4-20	.5	2	.156	3/16	9/32	7/16	3/4	1/32	5/32	1/4
CL-6-RHRP	3/8-16	.75	3	.250	9/32	7/16	5/8		1/8	3/16	3/8
CL-8-RHRP	1/2-13	1	4	.312	3/8	9/16	13/16	1	5/32	1/4	1/2
CL-10-RHRP	5/8-11	1.25	5	.375	7/16	11/16	1			5/16	5/8

PULL RING, NON-LOCKING TYPE — STAINLESS STEEL (INCH)

PART NO.	A	END FORCE (LBS)		B DIA	C	D	E	F DIA	G	H	J
		INITIAL	FINAL								
CL-4-RHRP-S	1/4-20	.5	2	.156	3/16	9/32	7/16	3/4	1/32	5/32	1/4
CL-6-RHRP-S	3/8-16	.75	3	.250	9/32	7/16	5/8		1/8	3/16	3/8
CL-8-RHRP-S	1/2-13	1	4	.312	3/8	9/16	13/16	1	5/32	1/4	1/2
CL-10-RHRP-S	5/8-11	1.25	5	.375	7/16	11/16	1			5/16	5/8

HAND-RETRACTABLE PLUNGERS

STEEL: 1215 BODY, 1215 PLUNGER CARBURIZED-HARDENED, 17-7PH SPRING
 ALL STEEL COMPONENTS ZINC PLATED CLEAR CHROMATE
 STAINLESS STEEL: 300 SERIES

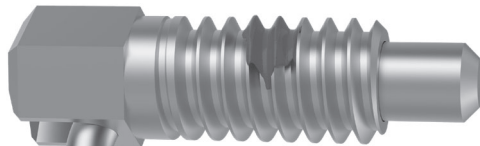

5/8-11

Spring-loaded plunger that locks in retracted position. Convenient L handle for quick retraction and locking.

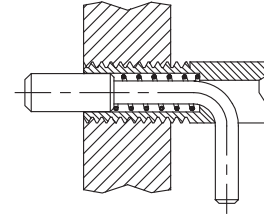

Extended Position

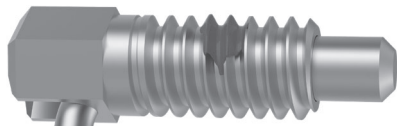

1/2-13

**L Handle
Short Stroke
(Locking Type)**

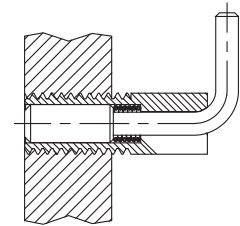

Retracted Position

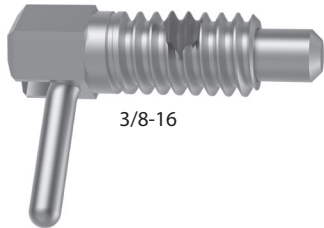

3/8-16

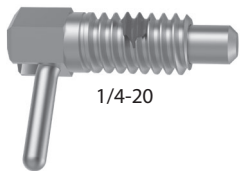

1/4-20

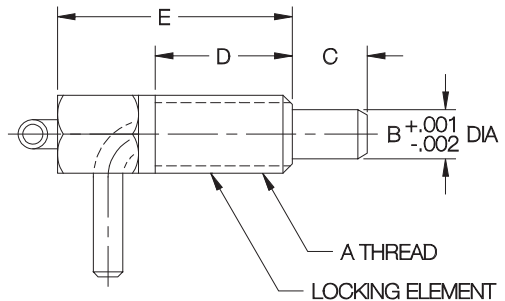
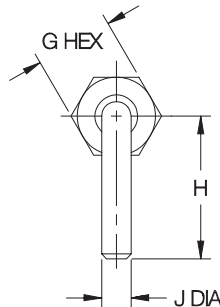

L HANDLE, SHORT STROKE — STEEL (INCH)

PART NO.	A	END FORCE (LBS)		B DIA	C	D	E	G	H	J DIA
		INITIAL	FINAL							
CL-40-LHRP	1/4-20	.12	.5	.156	3/16	7/16	3/4	1/4	9/16	3/32
CL-60-LHRP	3/8-16	.25	1.25	.250	5/16	5/8	1-1/8	3/8	3/4	9/64
CL-80-LHRP	1/2-13	.5	2	.312	13/32	7/8	1-1/2	1/2	1	3/16
CL-100-LHRP	5/8-11	.75	2.5	.375	1/2	1-1/8	1-7/8	5/8	1-3/16	

L HANDLE, SHORT STROKE — STAINLESS STEEL (INCH)

PART NO.	A	END FORCE (LBS)		B DIA	C	D	E	G	H	J DIA
		INITIAL	FINAL							
CL-40-LHRP-S	1/4-20	.12	.5	.156	3/16	7/16	3/4	1/4	9/16	3/32
CL-60-LHRP-S	3/8-16	.25	1.25	.250	5/16	5/8	1-1/8	3/8	3/4	9/64
CL-80-LHRP-S	1/2-13	.5	2	.312	13/32	7/8	1-1/2	1/2	1	3/16
CL-100-LHRP-S	5/8-11	.75	2.5	.375	1/2	1-1/8	1-7/8	5/8	1-3/16	

HAND-RETRACTABLE PLUNGERS

STEEL: 1215 BODY, 1215 PLUNGER CARBURIZED-HARDENED, 17-7PH SPRING
 ALL STEEL COMPONENTS ZINC PLATED CLEAR CHROMATE
 STAINLESS STEEL: 300 SERIES

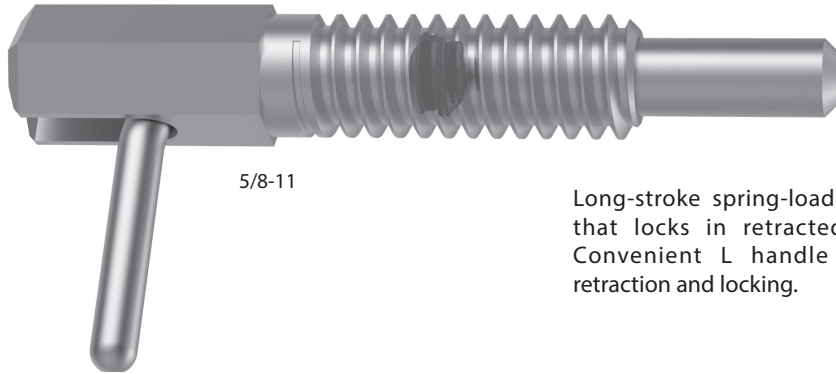

5/8-11

Long-stroke spring-loaded plunger that locks in retracted position. Convenient L handle for quick retraction and locking.

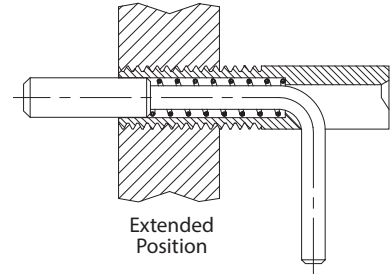

Extended Position

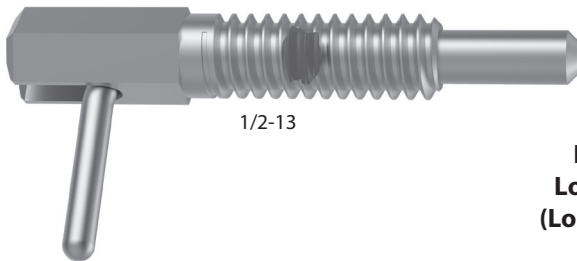

1/2-13

**L Handle
 Long Stroke
 (Locking Type)**

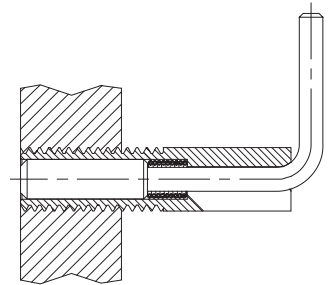

Retracted Position

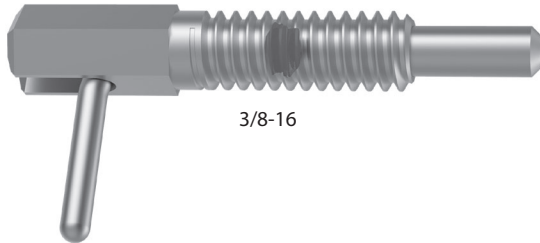

3/8-16

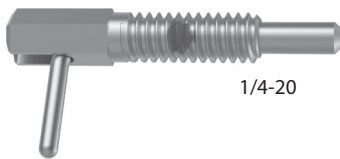
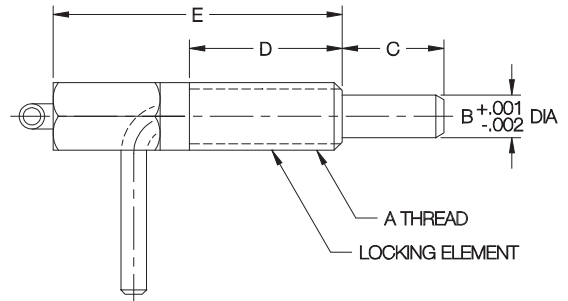
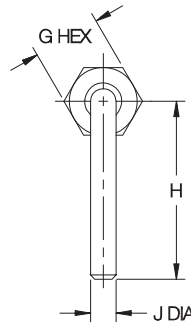

1/4-20

L HANDLE, LONG STROKE — STEEL (INCH)

PART NO.	A	END FORCE (LBS)		B DIA	C	D	E	G	H	J DIA
		INITIAL	FINAL							
CL-4-LHRP	1/4-20	.5	2.5	.156	3/8	5/8	1-1/4	1/4	5/8	3/32
CL-6-LHRP	3/8-16	.75	3.75	.250	9/16	1-1/16	2	3/8	15/16	9/64
CL-8-LHRP	1/2-13	1	5	.312	3/4	1-1/8	2-1/8	1/2	1-1/4	3/16
CL-10-LHRP	5/8-11			.375	1	1-3/4	3	5/8	1-5/16	

L HANDLE, LONG STROKE — STAINLESS (INCH)

CL-4-LHRP-S	1/4-20	.5	2.5	.156	3/8	5/8	1-1/4	1/4	5/8	3/32
CL-6-LHRP-S	3/8-16	.75	3.75	.250	9/16	1-1/16	2	3/8	15/16	9/64
CL-8-LHRP-S	1/2-13	1	5	.312	3/4	1-1/8	2-1/8	1/2	1-1/4	3/16
CL-10-LHRP-S	5/8-11			.375	1	1-3/4	3	5/8	1-5/16	

HAND-RETRACTABLE PLUNGERS

KNOB: MATTE BLACK FIBER-REINFORCED NYLON THERMOPLASTIC
 PLUNGER: STEEL, HEAT TREATED.
 BODY: STEEL, BLACK OXIDE FINISH

4

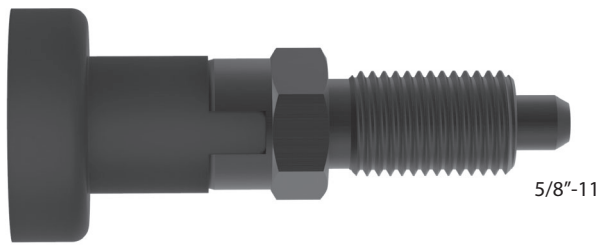

5/8"-11

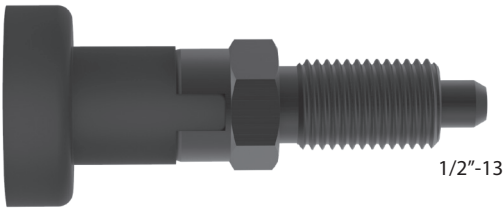

1/2"-13

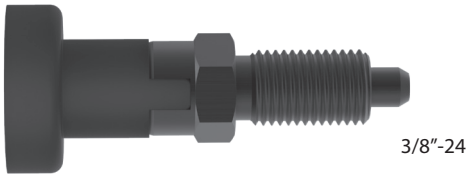

3/8"-24

**Knob Handle
(Locking Type)**

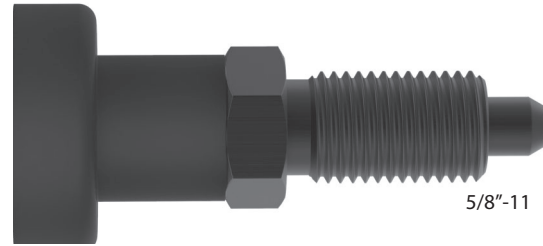

5/8"-11

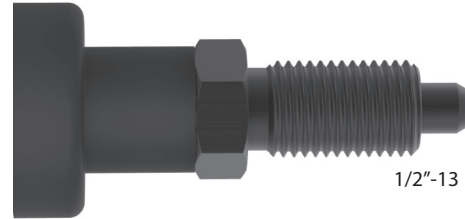

1/2"-13

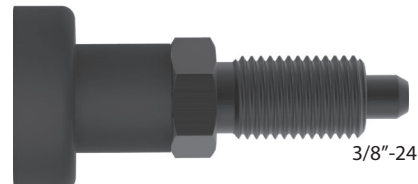

3/8"-24

**Knob Handle
(Non-Locking Type)**

Precision indexing plunger with a attractive knob handle for convenient retraction. Threaded-body version provides adjustment and can be secured with an optional Jam Nut. High strength and durability in an extremely compact assembly. Hardened and ground plunger tip has a slight taper for easy alignment. Available in two types, locking and non-locking.

Locking type has a spring-loaded plunger that locks in retracted position. To lock, pull knurled knob back and turn 90°. Body is notched at 90° to keep the knob in its retracted position.

Non-locking type has a spring-loaded plunger that stays extended by spring force except when manually held in retracted position.

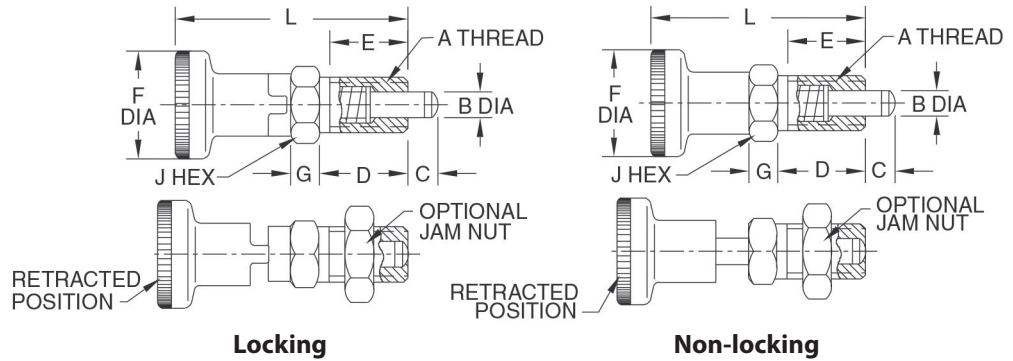

LOCKING TYPE (INCH)

PART NO.	A	B DIA		C	D	E	F DIA	G	J	L	END FORCE (LBS)		JAM NUT (OPTIONAL)
		NOMINAL	ACTUAL								INITIAL	FINAL	
CL-6-HRPK-L	3/8-24	5mm	.1961/.1953	.20	.67	.59	.83	.20	12mm	1.73	1.6	3.6	CL-6-FJN
CL-8-HRPK-L	1/2-13	6mm	.2354/.2346	.24	.79	.67	.98	.24	14mm	2.09	1.5	3.4	CL-8-JN
CL-10-HRPK-L	5/8-11	8mm	.3142/.3134	.28	1.02	.91	1.22	.31	19mm	2.62	2.7	7.0	CL-10-JN

NON-LOCKING TYPE (INCH)

CL-6-HRPK-N	3/8-24	5mm	.1961/.1953	.20	.67	.59	.83	.20	12mm	1.73	1.6	3.6	CL-6-FJN
CL-8-HRPK-N	1/2-13	6mm	.2354/.2346	.24	.79	.67	.98	.24	14mm	2.09	1.5	3.4	CL-8-JN
CL-10-HRPK-N	5/8-11	8mm	.3142/.3134	.28	1.02	.91	1.22	.31	19mm	2.62	2.7	7.0	CL-10-JN

HAND-RETRACTABLE PLUNGERS

KNOB: MATTE BLACK FIBER-REINFORCED NYLON THERMOPLASTIC
 PLUNGER: STEEL, HEAT TREATED
 BODY PLATE: STEEL, ZINC PLATED CLEAR CHROMATE

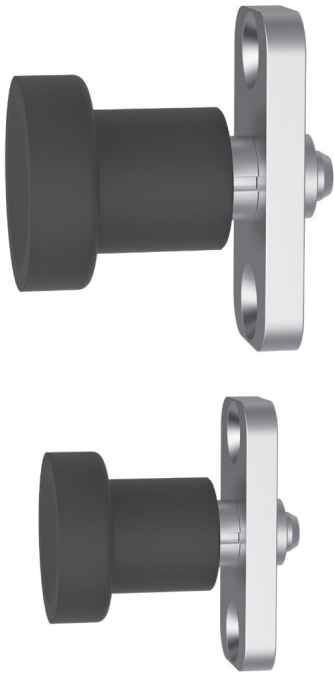

**Knob Handle
with Mounting Plate
(Locking Type)**

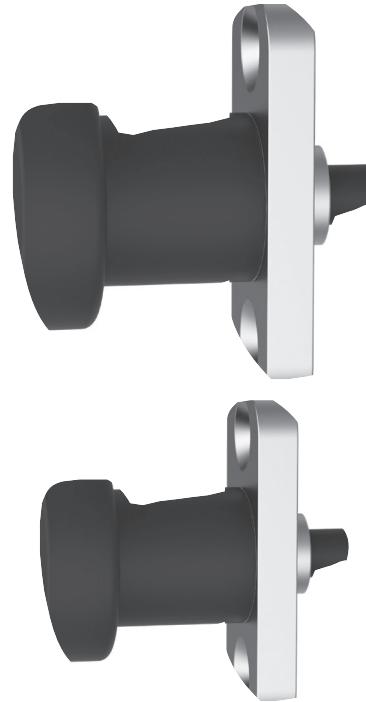

**Knob Handle
with Mounting Plate
(Non-Locking Type)**

Precision indexing plunger with an attractive knob handle for convenient retraction. Mounting-plate version installs in a fixed position with two flat-head screws, and is available with either a short or long plunger extension. High strength and durability in an extremely compact assembly. Hardened and ground plunger tip has a slight taper for easy alignment. Available in two types, locking and non-locking, each with a choice of short or long plunger extension.

Locking type has a spring-loaded plunger that locks in retracted position. To lock, pull knurled knob back and turn 90°. The body is notched at 90° to keep the knob in its retracted position.

Non-locking type has a spring-loaded plunger that stays extended by spring force except when manually held in retracted position.

**Locking
and
Non-Locking**

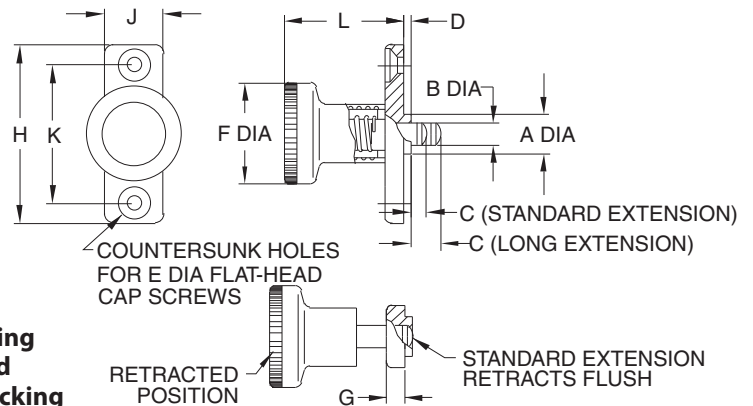

LOCKING TYPE

PART NO. STANDARD EXTENSION	PART NO. LONG EXTENSION	A DIA		B DIA		C		D	E DIA	F DIA	G	H	J	K	L	END FORCE (LBS)	
		NOMINAL	ACTUAL	NOMINAL	ACTUAL	STANDARD EXTENSION	LONG EXTENSION									INITIAL	FINAL
CL-8-HRPM-L	CL-8-HRPM-LE	10mm	.393/.390	6mm	.2354/.2346	.24	.55 (24 stroke)	.10	#8 or M4	.98	.18	1.57	.71	1.181	1.12	1.9	4.9
CL-10-HRPM-L	CL-10-HRPM-LE	12mm	.472/.468	8mm	.3142/.3134	.31	.71 (31 stroke)		#10 or M5	1.22	.22	1.81	.79	1.339	1.32	3.5	6.3

NON-LOCKING TYPE

CL-8-HRPM-N	CL-8-HRPM-NE	10mm	.393/.390	6mm	.2354/.2346	.24	.55 (24 stroke)	.10	#8 or M4	.98	.18	1.57	.71	1.181	1.12	1.9	4.9
CL-10-HRPM-N	CL-10-HRPM-NE	12mm	.472/.468	8mm	.3142/.3134	.31	.71 (31 stroke)		#10 or M5	1.22	.22	1.81	.79	1.339	1.32	3.5	6.3

HAND-RETRACTABLE PLUNGERS

PLUNGER: MILD STEEL, CARBURIZED HARDENED, ZINC PLATED CLEAR CHROMATE
 BODY: MILD STEEL, ZINC PLATED CLEAR CHROMATE
 SPRING: SPRING STEEL



This unique, quick-release pull pin positively locks in extended position. The hand-retractable plunger tip automatically locks in the forward position unless manually disengaged by pulling the ring, rather than being held forward by spring force. Slight taper on plunger tip for easy alignment. **Patent no. 8,821,061.** Made in USA.

4

**Pull Ring
(Extended-Locking Type)**

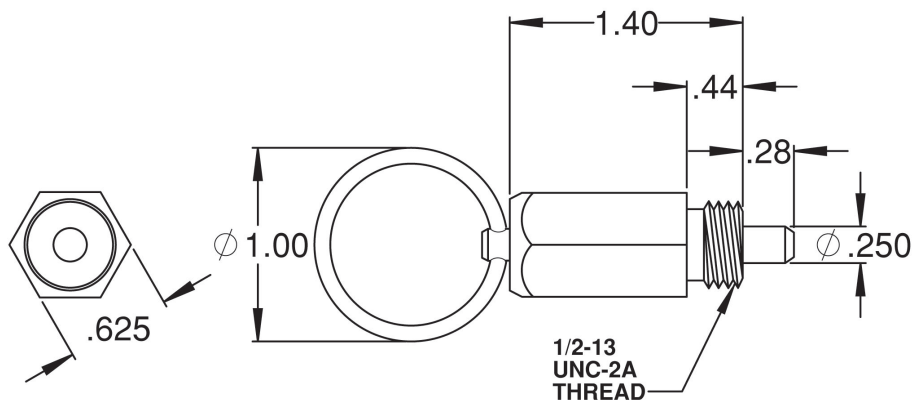

INCH

PART NO.	BODY THREAD	END FORCE	PLUNGER DIA	PLUNGER LENGTH	BODY LENGTH	RING DIA	BODY HEX
CL-8-EHRP	1/2-13	Locked	.250	.28	1.40	1.00	5/8

TAPERED INDEX PLUNGERS

PLUNGER, BODY, CAM, AND BUSHING: 1144 STEEL, HEAT TREATED. CENTER SHAFT: 11L44 STEEL. SPRING: MUSIC WIRE.
BALL KNOB: BLACK PHENOLIC PLASTIC WITH MOLDED-IN BRASS INSERT

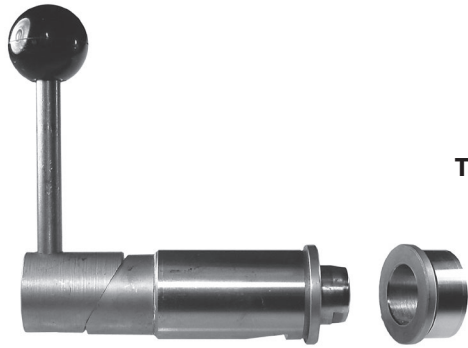

**Tapered Index Plungers
Rotary Cam
Standard Mount**

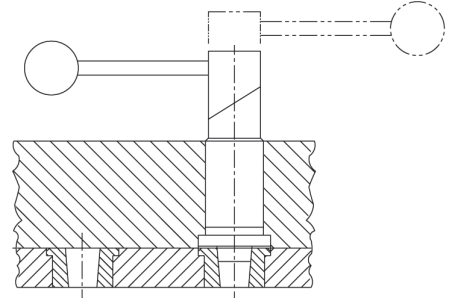

Index Plungers are precision, heavy-duty assemblies with a retractable spring-loaded plunger and a matching locating bushing. Tapered Index Plungers feature a 15° taper on the plunger tip with a mating taper on the bushing. The taper makes alignment easier and also eliminates any binding during retraction. Straight Index Plungers have an entirely cylindrical plunger with a slight radius at the tip, used together with a straight bushing. A straight plunger provides slightly greater positional accuracy. Order plunger and bushing separately.

The rotary-cam version completely retracts when the handle is rotated 180°. Cam surfaces are hardened steel. The standard-mount configuration has a precision ground body with a whistle notch for orientation with a setscrew (also available with a slightly oversize unground body to allow custom grinding to size). Index Plungers are manufactured with precision working tolerances and are designed for very light interference-fit installations to avoid binding of the mechanism. Set screws with nylon tip inserts are recommended. Set screws should firmly contact the whistle notch, but not exert significant force.

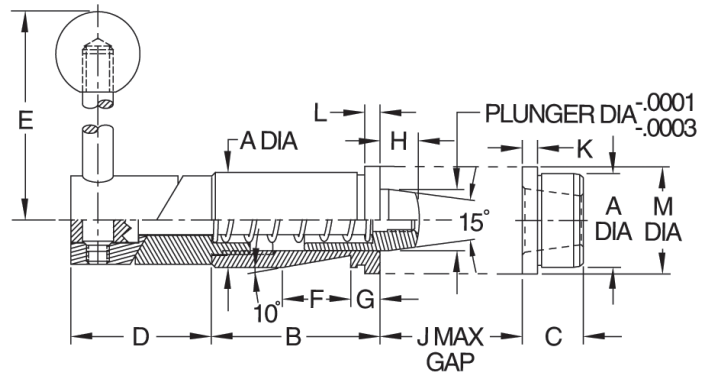

TAPERED INDEX PLUNGERS — ROTARY CAM, STANDARD MOUNT (INCH)

PART NO. INDEX PLUNGER	PART NO. BUSHING	PLUNGER DIA	A DIA			B	C	D	E	F	G	H	J	K	L	M DIA
			NOMINAL	GROUND	UNGROUND											
CL-22018-TIP	CL-22032-TIPB	1/2	3/4	.7518/.7515	—	1-3/8	1/2	1-1/8	3	7/16	5/16	5/16	3/32	1/8	1/8	7/8
CL-22016-TIP	CL-22030-TIPB			—	.766/.765											
CL-22118-TIP	CL-22132-TIPB	3/4	1-1/8	1.1268/1.1265	—	2	5/8	1-5/8	3-1/2	9/16	3/8	13/32	1/8	1/8	1/8	1-1/4
CL-22116-TIP	CL-22130-TIPB			—	1.141/1.140											
CL-22218-TIP	CL-22232-TIPB	1	1-1/2	1.5021/1.5018	—	2-1/4	3/4	2-1/8	4-1/2	11/16	7/16	7/16	1/8	1/8	1/8	1-5/8
CL-22216-TIP	CL-22230-TIPB			—	1.516/1.515											

TAPERED INDEX PLUNGERS — ROTARY CAM, STANDARD MOUNT (METRIC)

PART NO. FOR INDEX PLUNGER	PART NO. BUSHING	PLUNGER DIA (mm)	A DIA NOMINAL (mm)	A DIA ACTUAL (mm)	B (mm)	C (mm)	D (mm)	E (mm)	F (mm)	G (mm)	H (mm)	J (mm)	K (mm)	L (mm)	M DIA (mm)
CLM-22018-TIP	CLM-22032-TIPB	12	20	20.046 / 20.038 (Ground)	35	12	28.5	76	11	8	8	2.4	3	3	22
CLM-22118-TIP	CLM-22132-TIPB	20	30	30.046 / 30.038 (Ground)	51	16	41.5	89	14	9.5	10.5	3.2	3	3	32

TAPERED INDEX PLUNGERS

PLUNGER, BODY, RETAINER, AND CAM: 1144 STEEL, HEAT TREATED. CENTER SHAFT: 11L44 STEEL. SPRING: MUSIC WIRE.
BALL KNOB: BLACK PHENOLIC PLASTIC WITH MOLDED-IN BRASS INSERT

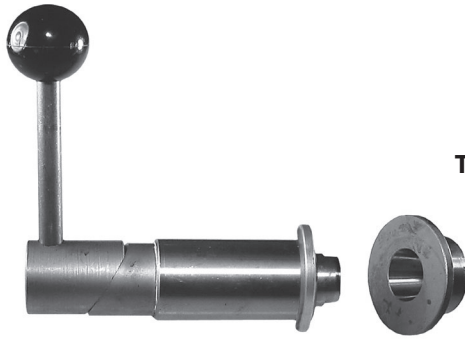

**Tapered Index Plungers
Rotary Cam
Flange Mount**

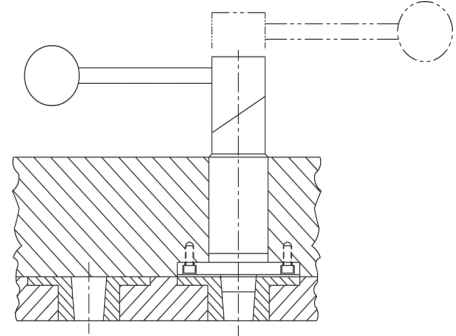

4

Index Plungers are precision, heavy-duty assemblies with a retractable spring-loaded plunger and a matching locating bushing. Tapered Index Plungers feature a 15° taper on the plunger tip with a mating taper on the bushing. The taper makes alignment easier and also eliminates any binding during retraction. Straight Index Plungers have an entirely cylindrical plunger with a slight radius at the tip, used together with a straight bushing. A straight plunger provides slightly greater positional accuracy. Order plunger and bushing separately.

The rotary-cam version completely retracts when the handle is rotated 180°. Cam surfaces are hardened steel. The flange-mount configuration shown here has a precision ground body with a flange used for orientation by fastening with two Socket-Head Cap Screws (also available with a slightly oversize unground body to allow custom grinding to size). Flange mounting is designed for installations where a cross hole for a set screw is not practical. Index plungers are manufactured with precision working tolerances and are designed for a very light interference-fit installations to avoid binding of the mechanism.

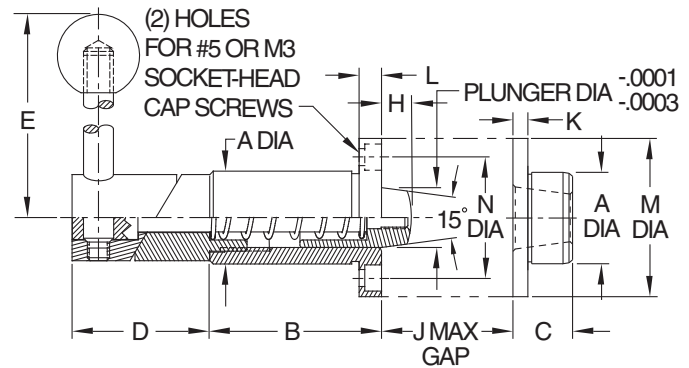

TAPERED INDEX PLUNGERS — ROTARY CAM, FLANGE MOUNT (INCH)

PART NO. INDEX PLUNGER	PART NO. BUSHING	PLUNGER DIA	A DIA			B	D	E	H	J	L	M DIA	N DIA
			NOMINAL	GROUND	UNGROUND								
CL-22019-TIP	CL-22033-TIPB	1/2	3/4	.7518/.7515	—	1-3/8	1-1/8	3	5/16	3/32	3/16	1-5/16	1
CL-22017-TIP	CL-22031-TIPB			—	.766/.765								
CL-22119-TIP	CL-22133-TIPB	3/4	1-1/8	1.1268/1.1265	—	2	1-1/2	3-1/2	13/32	1/8	3/16	1-11/16	1-3/8
CL-22117-TIP	CL-22131-TIPB			—	1.141/1.140								

TAPERED INDEX PLUNGERS — ROTARY CAM, FLANGE MOUNT (METRIC)

PART NO. INDEX PLUNGER	PART NO. BUSHING	PLUNGER DIA	A DIA			B	D	E	H	J	L	M DIA	N DIA
			NOMINAL	GROUND	UNGROUND								
CLM-22019-TIP	CLM-22033-TIPB	12mm	20mm	.7892/.7889	----	35mm	28-1/2	76mm	8	2.4	5mm	34mm	25mm
CLM-22119-TIP	CLM-22133-TIPB	20mm	30mm	1.1829/1.1826	----	51mm	45-1/2	89mm	10.5	3.2	5mm	42mm	35mm

TAPERED INDEX PLUNGERS

PLUNGER, BODY, CAM, AND BUSHING: 1144 STEEL, HEAT TREATED. CENTER SHAFT: 11L44 STEEL. SPRING: MUSIC WIRE.

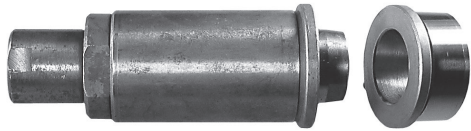

**Tapered Index Plunger
Blank Machinable End**

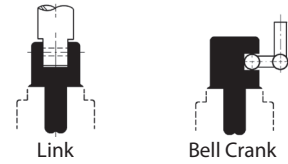
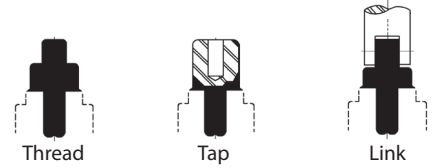

Index Plungers are precision, heavy-duty assemblies with a retractable spring-loaded plunger and a matching locating bushing. Tapered Index Plungers feature a 15° taper on the plunger tip with a mating taper in the bushing. The taper makes alignment easier and also eliminates any binding during retraction. Straight Index Plungers have an entirely cylindrical plunger with a slight radius at the tip, used together with a straight bushing. A straight plunger provides slightly greater positional accuracy. Order plunger and bushing separately.

The version shown on this page has a blank machinable end for easy adaptation to various actuating devices, including automated setups. Precision ground body (also available with a slightly oversize unground body to allow custom grinding to size). Index Plungers are manufactured with precision working tolerances and are designed for a very light interference-fit installations to avoid binding of the mechanism.

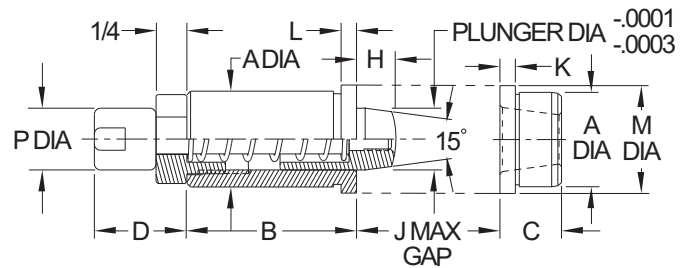

TAPERED INDEX PLUNGERS — BLANK MACHINABLE END (INCH)

PART NO. INDEX PLUNGER	PART NO. BUSHING	PLUNGER DIA	A DIA			B	C	D	H	J	K	L	M DIA	P DIA
			NOMINAL	GROUND	UNGROUND									
CL-22014-TIP	CL-22032-TIPB	1/2	3/4	.7518/.7515	—	1-3/8	1/2	3/4	5/16	3/32	1/8	1/8	7/8	1/2
CL-22012-TIP	CL-22030-TIPB			—	.766/.765									
CL-22114-TIP	CL-22132-TIPB	3/4	1-1/8	1.1268/1.1265	—	2	5/8	1	3/8	1/8	1/8	1/8	1-1/4	3/4
CL-22112-TIP	CL-22130-TIPB			—	1.141/1.140									
CL-22214-TIP	CL-22232-TIPB	1	1-1/2	1.5021/1.5018	—	2-1/4	3/4	1-1/4	3/8	1/8	1/8	1/8	1-5/8	15/16
CL-22212-TIP	CL-22230-TIPB			—	1.5021/1.5018									

STRAIGHT INDEX PLUNGERS

PLUNGER, BODY, CAM, AND BUSHING: 1144 STEEL, HEAT TREATED. CENTER SHAFT: 11L44 STEEL. SPRING: MUSIC WIRE.
BALL KNOB: BLACK PHENOLIC PLASTIC WITH MOLDED-IN BRASS INSERT

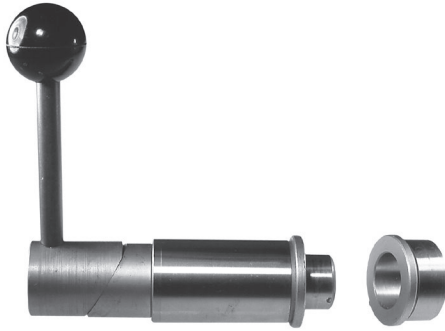

**Straight Index Plungers
Rotary Cam
Standard Mount**

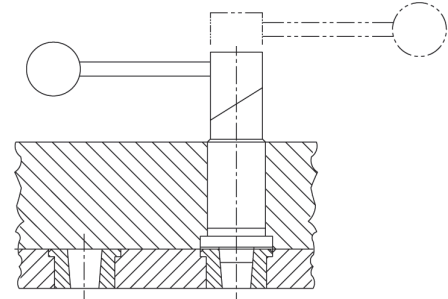

4

Index Plungers are precision, heavy-duty assemblies with a retractable spring-loaded plunger and a matching locating bushing. Tapered Index Plungers feature a 15° taper on the plunger tip with a mating taper on the bushing. The taper makes alignment easier and also eliminates any binding during retraction. Straight Index Plungers have an entirely cylindrical plunger with a slight radius at the tip, used together with a straight bushing. A straight plunger provides slightly greater positional accuracy. Order plunger and bushing separately.

The rotary-cam version completely retracts when the handle is rotated 180°. Cam surfaces are hardened steel. The standard-mount configuration has a precision ground body with a whistle notch for orientation with a setscrew (also available with a slightly oversize unground body to allow custom grinding to size). Index Plungers are manufactured with precision working tolerances and are designed for very light interference-fit installations to avoid binding of the mechanism. Set screws with nylon tip inserts are recommended. Set screws should firmly contact the whistle notch, but not exert significant force.

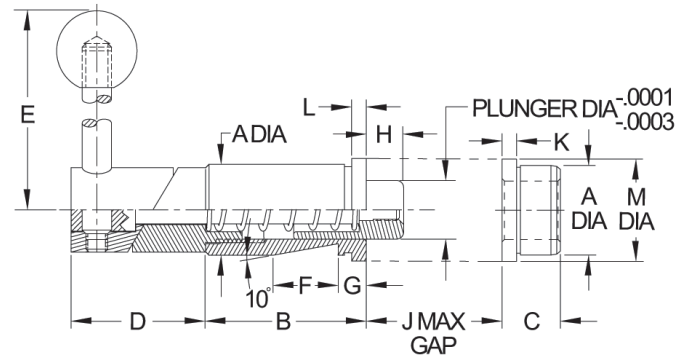

STRAIGHT INDEX PLUNGERS — ROTARY CAM, STANDARD MOUNT (INCH)

PART NO. INDEX PLUNGER	PART NO. BUSHING	PLUNGER DIA	A DIA			B	C	D	E	F	G	H	J	K	M DIA
			NOMINAL	GROUND	UNGROUND										
CL-22006-SIP	CL-22028-SIPB	1/2	3/4	.7518/.7515	—	1-3/8	1/2	1-1/8	3	7/16	5/16	5/16	3/32	1/8	7/8
CL-22004-SIP	CL-22026-SIPB			.766/.765											
CL-22106-SIP	CL-22128-SIPB	3/4	1-1/8	1.1268/1.1265	—	2	5/8	1-1/2	3-1/2	9/16	3/8	13/32	1/8	1/8	1-1/4
CL-22104-SIP	CL-22126-SIPB			1.141/1.140											
CL-22206-SIP	CL-22228-SIPB	1	1-1/2	1.5021/1.5018	—	2-1/4	3/4	1-7/8	4-1/2	11/16	7/16	7/16	1/8	1/8	1-5/8
CL-22204-SIP	CL-22226-SIPB			1.516/1.515											

STRAIGHT INDEX PLUNGERS — ROTARY CAM, STANDARD MOUNT (METRIC)

PART NO.	PLUNGER DIA (mm)	A DIA NOMINAL (mm)	A DIA ACTUAL (mm)	B (mm)	D (mm)	E (mm)	F (mm)	G (mm)	H (mm)	J (mm)	L (mm)	M DIA (mm)
CLM-22006-SIP	12	20	20.046 / 20.038 (Ground)	35	28.5	76	11	8	8	2.4	3	22
CLM-22106-SIP	20	30	30.046 / 30.038 (Ground)	51	38	89	14	9.5	10.5	3.2	3	32

STRAIGHT INDEX PLUNGERS

PLUNGER, BODY, RETAINER, AND CAM: 1144 STEEL, HEAT TREATED. CENTER SHAFT: 11L44 STEEL. SPRING: MUSIC WIRE.
BALL KNOB: BLACK PHENOLIC PLASTIC WITH MOLDED-IN BRASS INSERT

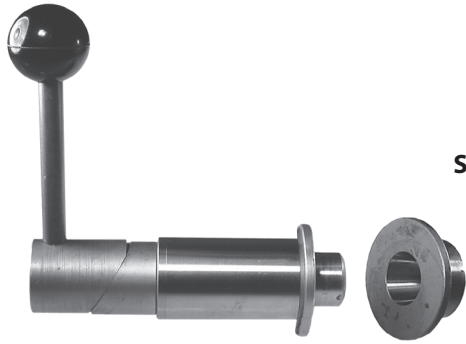

**Straight Index Plungers
Rotary Cam
Flange Mount**

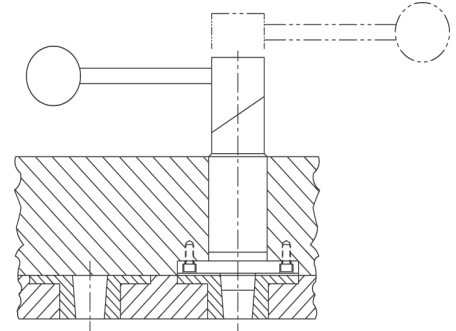

Index Plungers are precision, heavy-duty assemblies with a retractable spring-loaded plunger and a matching locating bushing. Tapered Index Plungers feature a 15° taper on the plunger tip with a mating taper on the bushing. The taper makes alignment easier and also eliminates any binding during retraction. Straight Index Plungers have an entirely cylindrical plunger with a slight radius at the tip, used together with a straight bushing. A straight plunger provides slightly greater positional accuracy. Order plunger and bushing separately.

The rotary-cam version completely retracts when the handle is rotated 180°. Cam surfaces are hardened steel. The flange-mount configuration shown here has a precision ground body with a flange used for orientation by fastening with two Socket-Head Cap Screws (also available with a slightly oversize unground body to allow custom grinding to size). Flange mounting is designed for installations where a cross hole for a set screw is not practical. Index plungers are manufactured with precision working tolerances and are designed for a very light interference-fit installations to avoid binding of the mechanism.

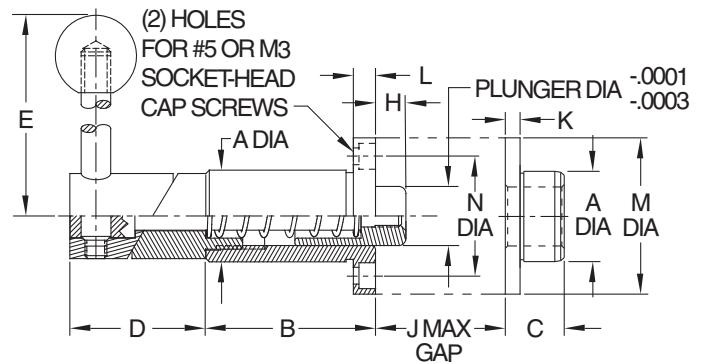

STRAIGHT INDEX PLUNGERS — ROTARY CAM, FLANGE MOUNT (INCH)

PART NO. INDEX PLUNGER	PART NO. BUSHING	PLUNGER DIA	A DIA			B	C	D	E	H	J	K	L	M DIA	N DIA
			NOMINAL	GROUND	UNGROUND										
CL-22007-SIP	CL-22029-SIPB	1/2	3/4	.7518/.7515	—	1-3/8	1/2	1-1/8	3	5/16	3/32	1/8	3/16	1-5/16	1
CL-22005-SIP	CL-22027-SIPB			—	.766/.765										
CL-22107-SIP	CL-22129-SIPB	3/4	1-1/8	1.1268/1.1265	—	2	5/8	1-1/2	3-1/2	13/32	1/8	1/8	3/16	1-11/16	1-3/8
CL-22105-SIP	CL-22127-SIPB			—	1.141/1.140										

STRAIGHT INDEX PLUNGERS — ROTARY CAM, FLANGE MOUNT (METRIC)

PART NO.	PLUNGER DIA (mm)	A DIA NOMINAL (mm)	A DIA ACTUAL (mm)	B (mm)	D (mm)	E (mm)	H (mm)	J (mm)	L (mm)	M DIA (mm)	N DIA (mm)
CLM-22007-SIP	12	20	20.046 / 20.038 (Ground)	35	28.5	76	8	2.4	5	34	25
CLM-22107-SIP	20	30	30.046 / 30.038 (Ground)	51	38	89	10.5	3.2	5	42	35

STRAIGHT INDEX PLUNGERS

PLUNGER, BODY, CAM, AND BUSHING: 1144 STEEL, HEAT TREATED. CENTER SHAFT: 1144 STEEL. SPRING: MUSIC WIRE.



**Straight Index Plunger
Blank Machinable End**

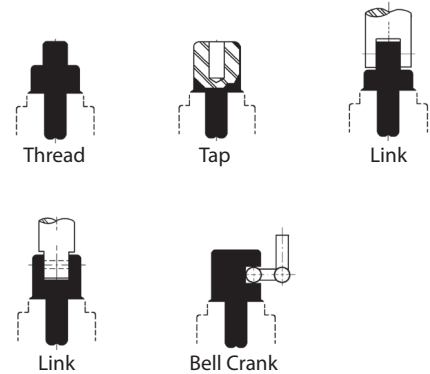

4

Index Plungers are precision, heavy-duty assemblies with a retractable spring-loaded plunger and a matching locating bushing. Tapered Index Plungers feature a 15° taper on the plunger tip with a mating taper in the bushing. The taper makes alignment easier and also eliminates any binding during retraction. Straight Index Plungers have an entirely cylindrical plunger with a slight radius at the tip, used together with a straight bushing. A straight plunger provides slightly greater positional accuracy. Order plunger and bushing separately.

The version shown on this page has a blank machinable end for easy adaptation to various actuating devices, including automated setups. Precision ground body (also available with a slightly oversize unground body to allow custom grinding to size). Index Plungers are manufactured with precision working tolerances and are designed for a very light interference-fit installations to avoid binding of the mechanism.

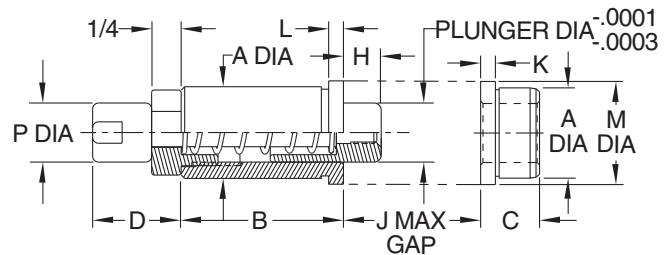

STRAIGHT INDEX PLUNGERS — BLANK MACHINABLE END (INCH)

PART NO. INDEX PLUNGER	PART NO. BUSHING	PLUNGER DIA	A DIA			B	C	D	H	J	K	L	M DIA	P DIA
			NOMINAL	GROUND	UNGROUND									
CL-22002-SIP	CL-22028-SIPB	1/2	3/4	.7518/.7515	—	1-3/8	1/2	3/4	5/16	3/32	1/8	1/8	7/8	1/2
CL-22102-SIP	CL-22128-SIPB	3/4	1-1/8	1.1268/1.1265	—	2	5/8	1	1/2	1/8	1/8	1/8	1-1/4	3/4
CL-22202-SIP	CL-22228-SIPB	1	1-1/2	1.5021/1.5018	—	2-1/4	3/4	1-1/4	5/8	1/8	1/8	1/8	1-5/8	15/16

SPRING STOP BUTTONS

BODY: ALUMINUM ALLOY; SPRING: SPRING STEEL (OR STAINLESS STEEL)
 PLUNGER: MILD STEEL, CARBURIZED-HARDENED, BLACK OXIDE FINISH (OR STAINLESS STEEL, OR DELRIN®)

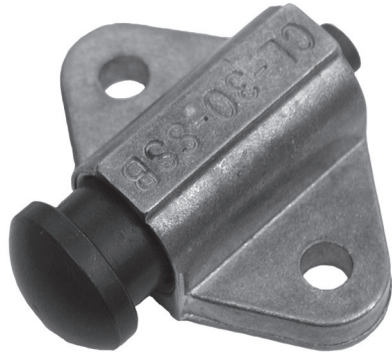

Large
CL-30A-SSB



Medium
CL-20A-SSB



Small
CL-10A-SSB

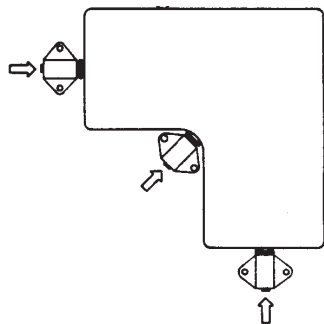

Spring Stop Buttons are ideal for holding a workpiece against its locators until clamps are in place, and for other light clamping jobs. Choice of three sizes in each type. The smallest of the three sizes is optionally available with light spring force.

Type A
Spherical Radius

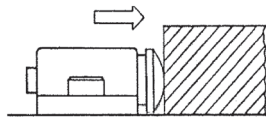

Spring-loaded plunger has a spherical radius to exert contact force at a single point. Choice of steel, stainless steel, or Delrin® plunger.

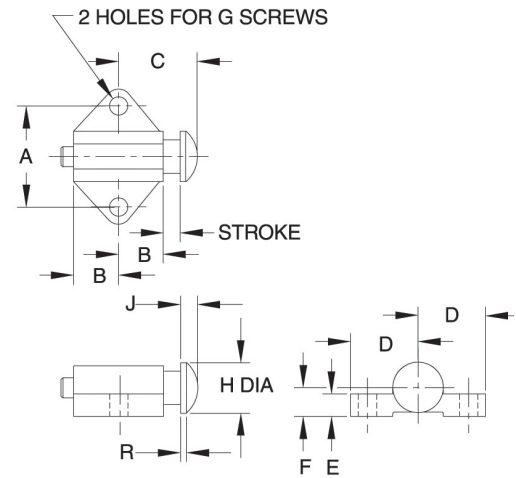

TYPE A – SPHERICAL RADIUS (STEEL)

PART NO. STANDARD FORCE	PART NO. LIGHT FORCE	STROKE	STANDARD CONTACT FORCE (LBS)			LIGHT CONTACT FORCE (LBS)			A	B	C	D	E	F	G DIA	H DIA	J	R
			INITIAL	HALFWAY	FINAL	INITIAL	HALFWAY	FINAL										
CL-10A-SSB	CL-10A-SSB-2	1/8	5	10	15	1.5	2	2.5	.656	11/32	19/32	7/16	3/16	7/32	#5 or M3	3/8	1/8	1/16
CL-20A-SSB	—	3/16	2	14	26	—	—	—	1.125	1/2	7/8	3/4	1/4	5/16	#10-32 or M5	9/16	3/16	1/16
CL-30A-SSB	—	1/4	16	32	48	—	—	—	1.500	11/16	1-7/32	1	1/4	7/16	1/4-20 or M6	13/16	9/32	9/64

TYPE A – SPHERICAL RADIUS (STAINLESS STEEL)

CL-10A-SSB-S	CL-10A-SSB-2-S	1/8	5	10	15	1.5	2	2.5	.656	11/32	19/32	7/16	3/16	7/32	#5 or M3	3/8	1/8	1/16
CL-20A-SSB-S	—	3/16	2	14	26	—	—	—	1.125	1/2	7/8	3/4	1/4	5/16	#10-32 or M5	9/16	3/16	1/16
CL-30A-SSB-S	—	1/4	16	32	48	—	—	—	1.500	11/16	1-7/32	1	1/4	7/16	1/4-20 or M6	13/16	9/32	9/64

TYPE A – SPHERICAL RADIUS (DELRIN®)

CL-10A-SSBN	CL-10A-SSBN-2	1/8	5	10	15	1.5	2	2.5	.656	11/32	19/32	7/16	3/16	7/32	#5 or M3	3/8	1/8	1/16
CL-20A-SSBN	—	3/16	2	14	26	—	—	—	1.125	1/2	7/8	3/4	1/4	5/16	#10-32 or M5	9/16	3/16	1/16
CL-30A-SSBN	—	1/4	16	32	48	—	—	—	1.500	11/16	1-7/32	1	1/4	7/16	1/4-20 or M6	13/16	9/32	9/64

SPRING STOP BUTTONS

BODY: ALUMINUM ALLOY; SPRING: SPRING STEEL
 PLUNGER: MILD STEEL, CARBURIZED-HARDENED, ZINC PLATED CLEAR CHROMATE



4

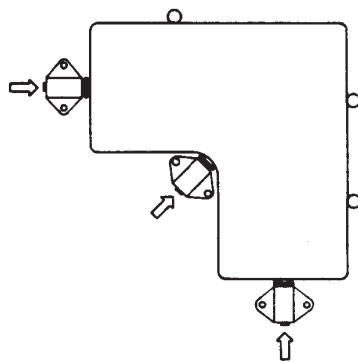

Spring Stop Buttons are ideal for holding a workpiece against its locators until clamps are in place, and for other light clamping jobs. Choice of three sizes in each type. The smallest of the three sizes is optionally available with light spring force.

Type B
Flat Face with Tang

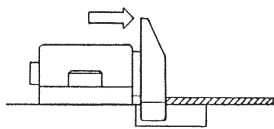

Designed for thin workpieces and sheets. Tang prevents sheet from sliding under plunger. Requires machining a slot in the fixture base for the tang. Large bevel on plunger makes loading easier.

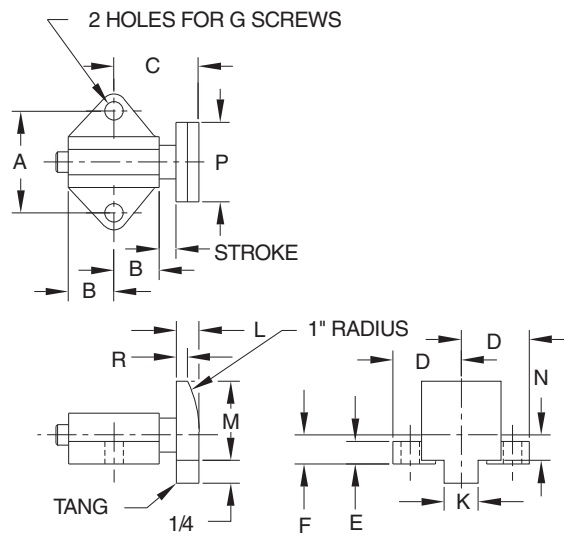

TYPE B – FLAT FACE WITH TANG (STEEL)

PART NO. STANDARD FORCE	PART NO. LIGHT FORCE	STROKE	STANDARD CONTACT FORCE (LBS)			LIGHT CONTACT FORCE (LBS)			A	B	C	D	E	F	G DIA	K	L	M	N	P	R
			INITIAL	HALFWAY	FINAL	INITIAL	HALFWAY	FINAL													
CL-10B-SSB	CL-10B-SSB-2	1/8	5	10	15	1.5	2	2.5	.656	11/32	21/32	7/16	3/16	7/32	#5 or M3	1/4	3/16	5/8	3/16	5/8	1/16
CL-20B-SSB	—	3/16	2	14	26	—	—	—	1.125	1/2	15/16	3/4	1/4	5/16	#10-32 or M5	3/8	1/4	7/8	9/32	7/8	3/32
CL-30B-SSB	—	1/4	16	32	48	—	—	—	1.500	11/16	1-5/16	1	1/4	7/16	1/4-20 or M6	1/2	3/8	1-1/4	13/32	1-1/4	3/32

SPRING STOP BUTTONS

BODY: ALUMINUM ALLOY; SPRING: SPRING STEEL
 PLUNGER: MILD STEEL, CARBURIZED-HARDENED, ZINC PLATED CLEAR CHROMATE



Large
CL-30C-SSB



Medium
CL-20C-SSB

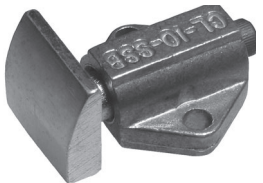

Small
CL-10C-SSB

4

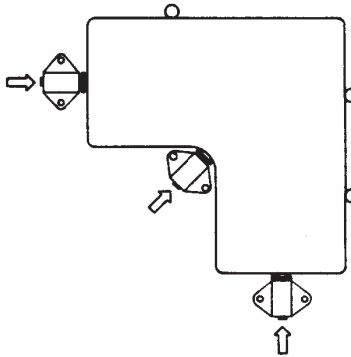

Spring Stop Buttons are ideal for holding a workpiece against its locators until clamps are in place, and for other light clamping jobs. Choice of three sizes in each type. The smallest of the three sizes is optionally available with light spring force.

Type C
Flat Face

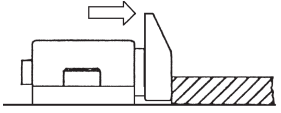

Flat contact surface is ideal for short workpieces. Large bevel on plunger makes loading easier.

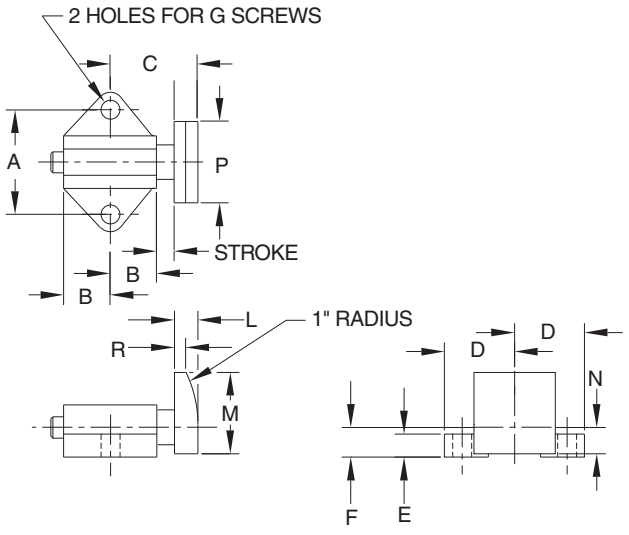

TYPE C – FLAT FACE (STEEL)

PART NO. STANDARD FORCE	PART NO. LIGHT FORCE	STROKE	STANDARD CONTACT FORCE (LBS)			LIGHT CONTACT FORCE (LBS)			A	B	C	D	E	F	G DIA	K	L	M	N	P	R
			INITIAL	HALFWAY	FINAL	INITIAL	HALFWAY	FINAL													
CL-10C-SSB	CL-10C-SSB-2	1/8	5	10	15	1.5	2	2.5	.656	11/32	21/32	7/16	3/16	7/32	#5 or M3	—	3/16	5/8	3/16	5/8	1/16
CL-20C-SSB	—	3/16	2	14	26	—	—	—	1.125	1/2	15/16	3/4	1/4	5/16	#10-32 or M5	—	1/4	7/8	9/32	7/8	3/32
CL-30C-SSB	—	1/4	16	32	48	—	—	—	1.500	11/16	1-5/16	1	1/4	7/16	1/4-20 or M6	—	3/8	1-1/4	13/32	1-1/4	3/32

HEAVY-DUTY SPRING STOPS

BODY: 1018 STEEL, BLACK OXIDE FINISH
 PLUNGER: 1018 STEEL, BLACK OXIDE FINISH
 SPRING: MUSIC WIRE

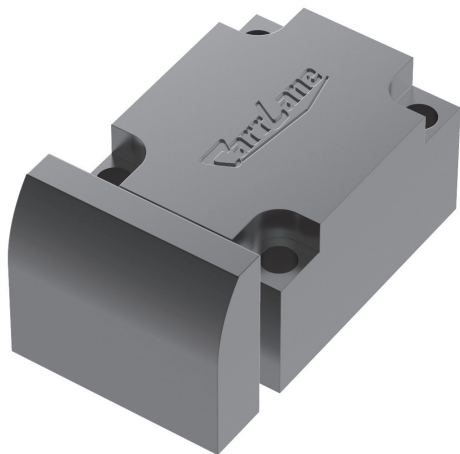

4

New item!

These massive spring-loaded stops are the largest and strongest of all the Spring Stop Buttons that we manufacture. Heavy-Duty Spring Stops have a large contact face and are useful for applying side force to hold a workpiece against its locators until clamps are in place. For some workholding applications, including many welding fixtures, a spring stop this strong can often be used without additional clamps. Mid-stroke spring force is approximately 100 lbs.

The large flat contact face is ideal for pushing flat-sided workpieces, with a radiused top edge to make loading easier. Heavy-Duty Spring Stops have a large-diameter plunger with a long bearing length to effectively resist loads applied to the top of the contact face. The plunger and body are both made of steel for maximum strength.

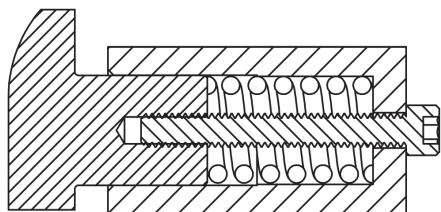

Heavy-Duty Spring Stops have a large-diameter plunger with a long bearing length to effectively resist loads applied to the top of the contact face.

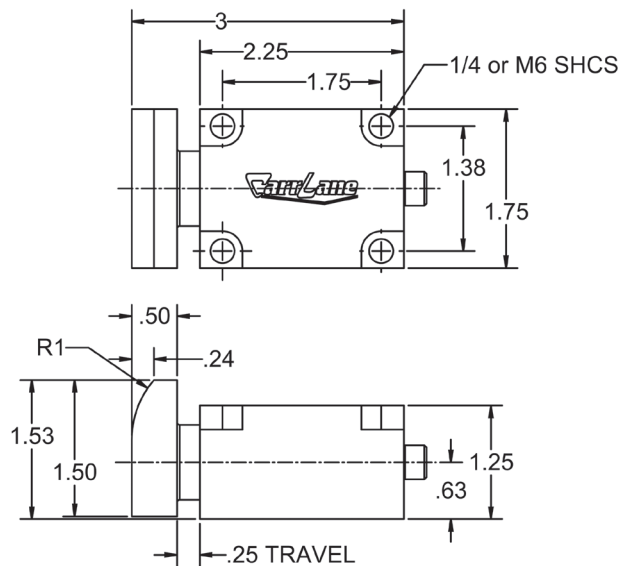

PART NO.	STROKE	CONTACT FORCE (LBS)		
		INITIAL	HALFWAY	FINAL
CL-100-HDSS	1/4	50	105	160

SPRING LOCATING PINS

PIN: MILD STEEL, CARBURIZED-HARDENED, ZINC PLATED CLEAR CHROMATE
 SPRING: MUSIC WIRE. HOUSING: ALUMINUM

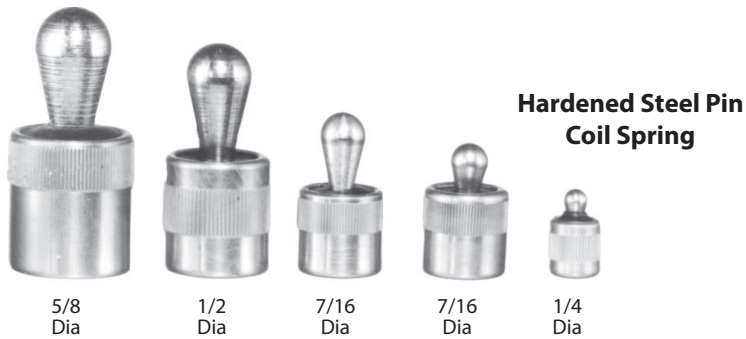

Our patented Spring Locating Pins are an extremely compact way to apply side force to a workpiece. The tapered contact pin is securely anchored in a spring base. Unit installs easily in a drilled hole. Available in five sizes, each in light, medium, or heavy force. Choice of steel, stainless steel, or Delrin® contact pin. **INFO+**: Also available with a tapped receptacle for custom contact pins. Our most popular version is shown on this page, with a durable case-hardened steel contact pin and aluminum body containing a coil spring. Protective rubber seal around contact pin keeps out chips and coolant. This type has the most travel, so it allows the most part-size variation.

4

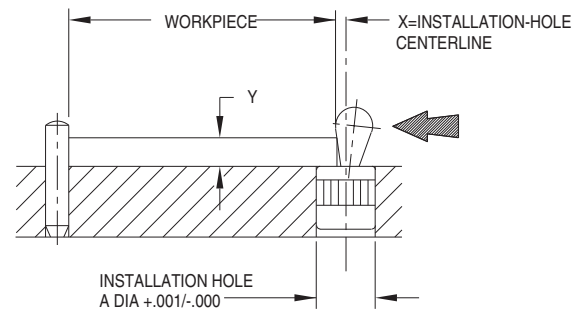
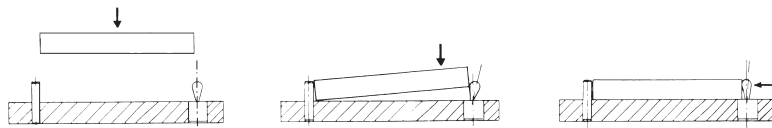

HARDENED STEEL PIN, COIL SPRING

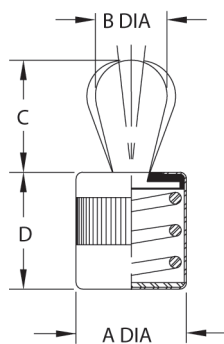

PART NO.	A DIA	APPROX SIDE FORCE (LBS)	ALLOWABLE WORKPIECE TOLERANCE	B DIA	C	D	X DIMENSION WHEN Y EQUALS						
							1/16	1/8	3/16	1/4	5/16	3/8	7/16 OR MORE
CL-4-SLP-1	1/4	2.2	.020	.118	.158	.268	.022	.024	.024	.024	.024	.024	.024
CL-4-SLP-2		4.5											
CL-4-SLP-3		9											
CL-7-SLP-1	7/16	4.5	.031	.197	.236	.434	—	.055	.055	.055	.055	.055	.055
CL-7-SLP-2		11											
CL-7-SLP-3		22											
CL-7A-SLP-1	7/16	9	.039	.236	.394	.434	—	—	.049	.059	.059	.059	.059
CL-7A-SLP-2		17											
CL-7A-SLP-3		34											
CL-8-SLP-1	1/2	11	.051	.315	.530	.520	—	—	.077	.087	.087	.087	.087
CL-8-SLP-2		22											
CL-8-SLP-3		45											
CL-10-SLP-1	5/8	22	.063	.394	.640	.705	—	—	—	.098	.107	.110	.110
CL-10-SLP-2		45											
CL-10-SLP-3		67											

SPRING LOCATING PINS

PIN: 300-SERIES STAINLESS STEEL
 SPRING: SOLID POLYURETHANE. HOUSING: ALUMINUM

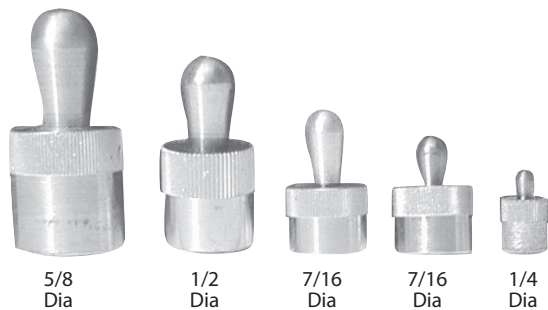

Stainless Steel Pin Solid Polyurethane Spring

Stainless steel contact pin is ideal for corrosive environments and hygienic applications. Solid polyurethane spring body is covered by an aluminum shell.

4

STAINLESS STEEL PIN, SOLID POLYURETHANE SPRING

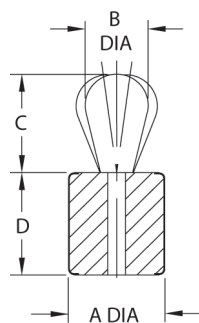

PART NO.	A DIA	APPROX SIDE FORCE (LBS)	ALLOWABLE WORKPIECE TOLERANCE	B DIA	C	D	X DIMENSION WHEN 7 EQUALS						
							1/16	1/8	3/16	1/4	5/16	3/8	7/16 OR MORE
CL-4-SLPS-1	1/4	2.2	.008	.118	.158	.008	.022	.024	.024	.024	.024	.024	.024
CL-4-SLPS-2		4.5											
CL-7-SLPS-1	7/16	6.7	.016	.197	.292	.016	—	.055	.055	.055	.055	.055	.055
CL-7-SLPS-2		13											
CL-7-SLPS-3		20											
CL-7A-SLPS-1	7/16	6.7	.016	.236	.473	.016	—	—	.049	.059	.059	.059	.059
CL-7A-SLPS-2		13											
CL-7A-SLPS-3		20											
CL-8-SLPS-1	1/2	11	.024	.315	.512	.024	—	—	—	.077	.087	.087	.087
CL-8-SLPS-2		22											
CL-8-SLPS-3		33											
CL-10-SLPS-1	5/8	22	.031	.394	.640	.658	—	—	—	—	.098	.107	.110
CL-10-SLPS-2		45											
CL-10-SLPS-3		67											

APPLICATION EXAMPLES

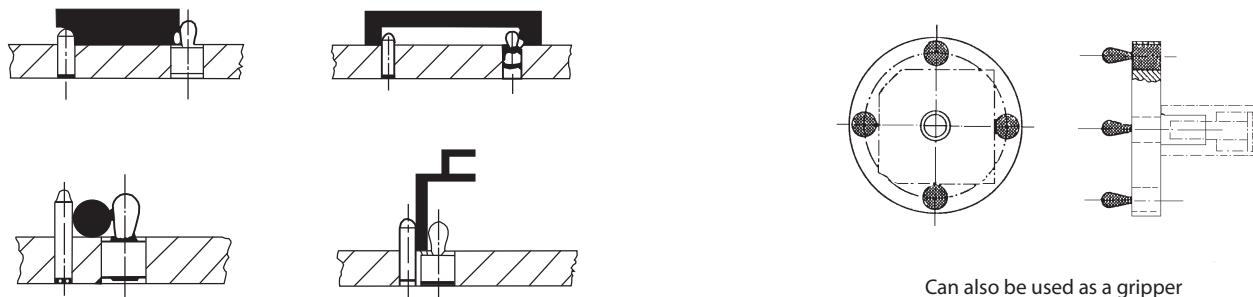

Can also be used as a gripper for light clamping.

SPRING LOCATING PINS

PIN: DELRIN®
 SPRING: SOLID POLYURETHANE. HOUSING: ALUMINIUM

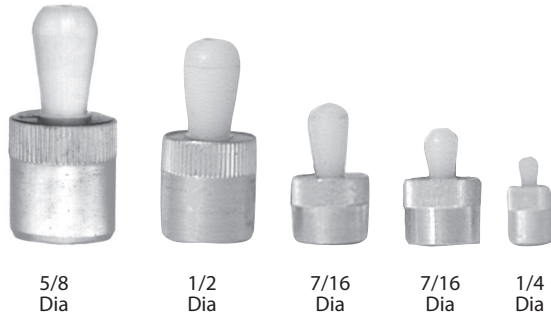

**Delrin® Pin
 Solid Polyurethane Spring**

Delrin® contact pin avoids marring soft or finished surfaces. Solid polyurethane body is covered by an aluminium shell.

4

DELRIN® PIN, SOLID POLYURETHANE SPRING

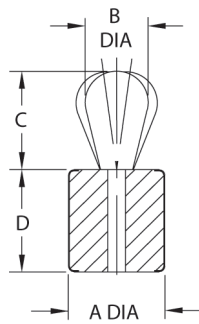

PART NO.	A DIA	APPROX SIDE FORCE (LBS)	ALLOWABLE WORKPIECE TOLERANCE	B DIA	C	D	X DIMENSION WHEN 7 EQUALS						
							1/16	1/8	3/16	1/4	5/16	3/8	7/16 OR MORE
CL-4-SLPP-1	1/4	2.2	.008	.118	.158	.291	.022	.024	.024	.024	.024	.024	.024
CL-4-SLPP-2		4.5											
CL-7-SLPP-1	7/16	6.7	.016	.197	.292	.371	—	.055	.055	.055	.055	.055	.055
CL-7-SLPP-2		13											
CL-7A-SLPP-1	7/16	6.7	.016	.236	.473	.371	—	—	.049	.059	.059	.059	.059
CL-7A-SLPP-2		13											
CL-8-SLPP-1	1/2	11	.024	.315	.512	.551	—	—	—	.077	.087	.087	.087
CL-8-SLPP-2		22											
CL-10-SLPP-1	5/8	22	.031	.394	.640	.658	—	—	—	—	.098	.107	.110
CL-10-SLPP-2		45											



Installation Tools

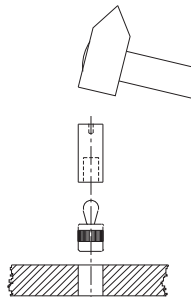

Handy tool to speed up installation of Spring Locating Pins. Use with any of the three types.

INSTALLATION TOOLS

PART NO.	USE TO INSTALL		
CL-4-SLPT	CL-4-SLP-x	CL-4-SLPS-x	CL-4-SLPP-x
CL-7-SLPT	CL-7-SLP-x	CL-7-SLPS-x	CL-7-SLPP-x
CL-7A-SLPT	CL-7A-SLP-x	CL-7A-SLPS-x	CL-7A-SLPP-x
CL-8-SLPT	CL-8-SLP-x	CL-8-SLPS-x	CL-8-SLPP-x
CL-10-SLPT	CL-10-SLP-x	CL-10-SLPS-x	CL-10-SLPP-x

SPRING LOCATING PINS

RECEPTACLE: MILD STEEL, BLACK OXIDE FINISH
 SPRING: MUSIC WIRE. HOUSING: ALUMINUM

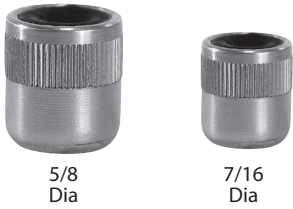

Tapped Receptacle for Custom Pin Coil Spring

This version has a tapped receptacle for installing custom contact pins. Available in two sizes, each in light, medium, or heavy force. Dimension E is a theoretical contact height which allows F maximum travel and provides the side force listed in the table. Taller pins will have more travel and less force, while shorter pins will have less travel and more force. To achieve maximum travel, the bottom diameter of the custom pin should be approximately equal to the C dimension.

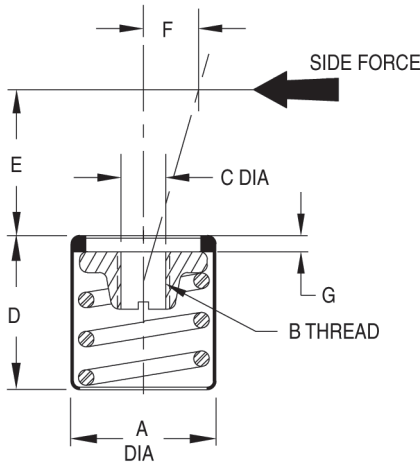
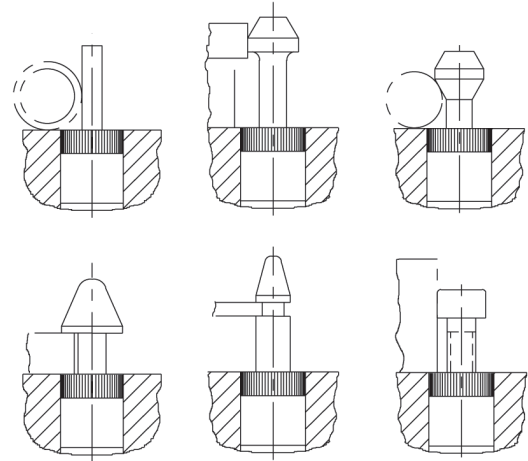

TAPPED RECEPTACLE FOR CUSTOM PIN, COIL SPRING

PART NO.	A DIA	B	APPROX SIDE FORCE (LBS)	C	D	E	F	G
CL-7-SLPR-1	7/16	#8-32	4.5	.164	.434	.16	.063	.04
CL-7-SLPR-2			11					
CL-7-SLPR-3			22					
CL-10-SLPR-1	5/8	1/4-20	22	.250	.705	.45	.126	.06
CL-10-SLPR-2			45					
CL-10-SLPR-3			67					



Eccentric Liners

Eccentric Liners provide additional adjustment for workpieces with looser tolerances. Steel.

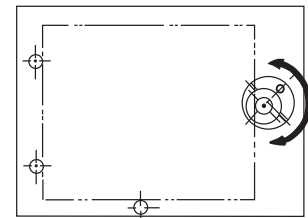

ECCENTRIC LINERS

PART NO.	FITS THESE PINS	A DIA		B DIA		C	D
		NOMINAL	ACTUAL	NOMINAL	ACTUAL		
CL-4-SLPE	CL-4-SLP-x CL-4-SLPS-x CL-4-SLPP-x	1/4	.2500 .2507	1/2	.5000 .4983	.390	.079
CL-7-SLPE	CL-7-SLP-x CL-7-SLPS-x CL-7-SLPP-x CL-7A-SLP-x CL-7A-SLPS-x CL-7A-SLPP-x	7/16	.4375 .4386	11/16	.6875 .6858	.469	.079
CL-8-SLPE	CL-8-SLP-x CL-8-SLPS-x CL-8-SLPP-x	1/2	.5000 .5011	3/4	.7500 .7480	.547	.079
CL-10-SLPE	CL-10-SLP-x CL-10-SLPS-x CL-10-SLPP-x	5/8	.6250 .6261	1	1.000 .9980	.705	.118

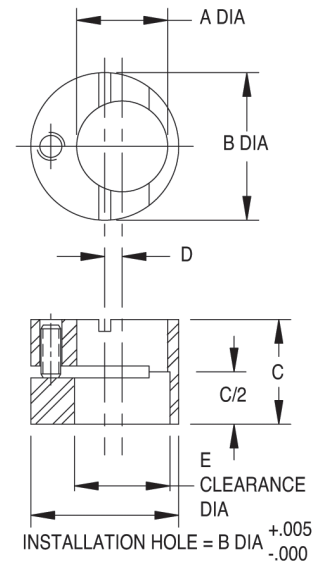
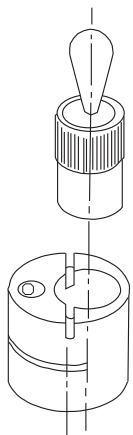

SUPPORTS, RESTS & FEET



Leveling Feet



Swivel Pads

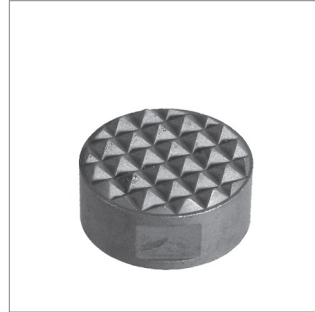

Grippers



Rest Buttons & Pads



Manual Work Supports



Screw Jacks



Eccentric Leveling Lugs

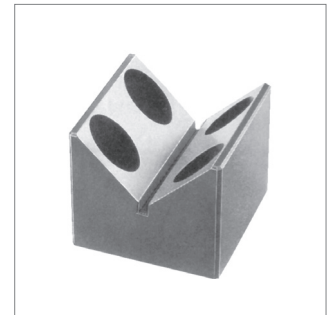

V Blocks

5

Also see:



Modular Supports & Locators
p. 417

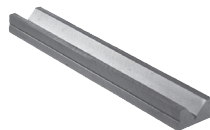

V Cast Sections
p. 392



Adjustable Locking Hubs
p. 400



Hydraulic Work Supports
p. 637

LEVELING FEET

TYPES



LEVELING FEET

High-quality, heavy-duty leveling foot with large-diameter pad. Large ball provides high load capacity with a 20° total swivel angle.



STUD LEVELING FEET

High-quality, heavy-duty leveling foot with large-diameter pad and integral stud. Stud and ball are one solid piece. Large ball provides high load capacity with a 20° total swivel angle.



JIG FEET LEVELING

Medium-duty leveling foot with removable pad. Lefthand thread in pad prevents backout while pad rotates and pivots freely.



JIG FEET LEVELING ASSEMBLIES

Complete leveling assembly includes radius-head screw, plate, and hex nut.

5

MATERIALS

STEEL

1215 steel, carburized-hardened, zinc plated yellow chromate. This material is the most economical and wear resistant choice for maximum load capacities.

STAINLESS STEEL

300-series stainless steel provides excellent resistance to rust, can be sanitized, and works well in corrosive environments. DFARS and RoHS compliant.

DELTRIN®

White Delrin® 500 is non-marking, will not rust and can be sanitized. Has the lowest load capacity of these materials.

LOAD RATINGS

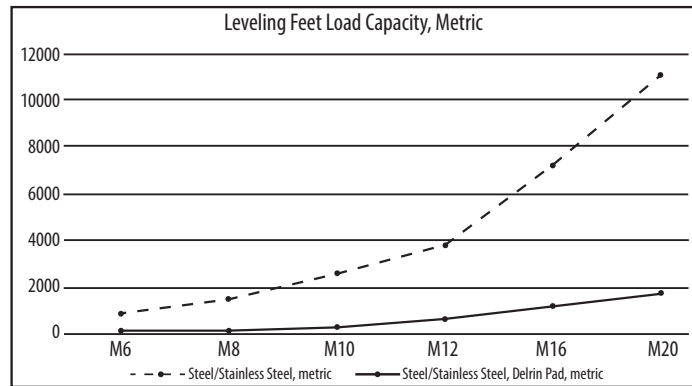
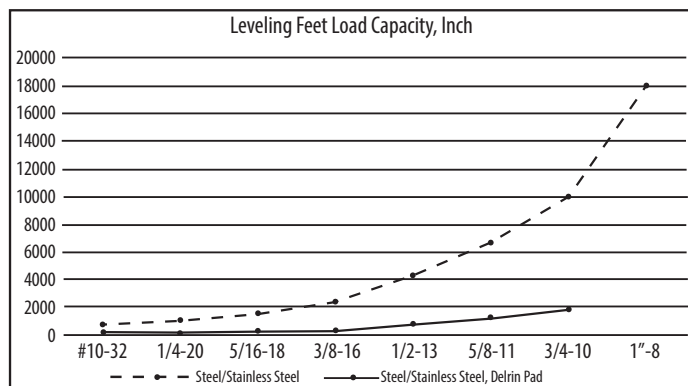

JIG FEET LEVELING

SCREW: 1215 STEEL, CARBURIZED-HARDENED, ZINC PLATED YELLOW CHROMATE
FOOT: 1215 STEEL, ZINC PLATED YELLOW CHROMATE



Medium-duty leveling foot with removable pad. Lefthand thread in pad prevents backout while pad rotates and pivots freely.
Patent no. 2,531,892.

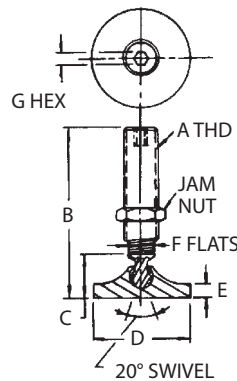
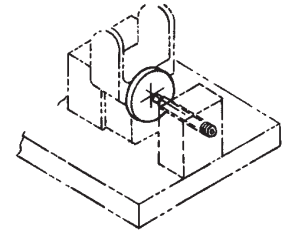

INCH

PART NO.	A	B	C	D DIA	E	F	G	*LOAD RATING (LBS)
CL-1-JFL	1/2-13	2-7/32	7/8	1-1/2	1/4	3/8	1/4	1,400
CL-2-JFL		4-7/32						430
CL-3-JFL	5/8-11	3-1/4	29/32	2	5/16	1/2	5/16	2,900
CL-4-JFL		5-1/4						1,200
CL-5A-JFL	3/4-10	3-1/2	1-1/6	2-1/2	3/8	9/16	3/8	3,700
CL-6-JFL		5-17/32						1,800
CL-8-JFL	1-8	5-19/32	1-19/32	3-1/2	1/2	3/4	1/2	6,400

METRIC

PART NO.	A THREAD	THREAD PITCH (mm)	B (mm)	C (mm)	D DIA (mm)	E (mm)	F (mm)	G (mm)	LOAD RATING (kg)
CLM-1-JFL	M12	1.75	55	22	38	6.5	10	6	630
CLM-2-JFL	M12	1.75	110	22	38	6.5	10	6	190
CLM-3-JFL	M16	2	85	23	51	8	13	8	1300
CLM-4-JFL	M16	2	135	23	51	8	13	8	540
CLM-5A-JFL	M20	2.5	90	27	63.5	9.5	17	10	1600
CLM-6-JFL	M20	2.5	140	27	63.5	9.5	17	10	800
CLM-8-JFL	M24	3	145	41	89	12.5	19	12	2900

5

JIG FEET LEVELING ASSEMBLIES

MILD STEEL, BLACK OXIDE FINISH

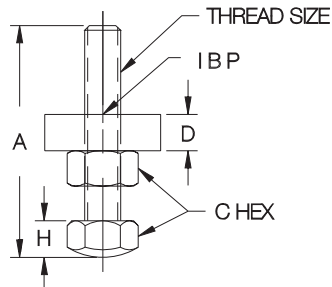
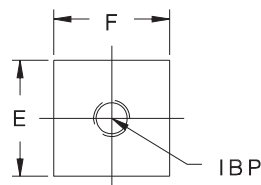
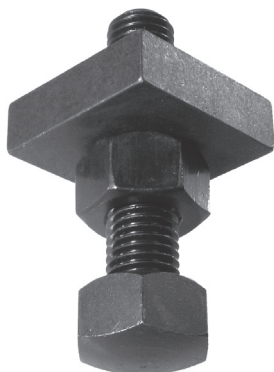

Complete leveling assembly includes radius-head screw, plate, and hex nut.

* Safe static load with stud securely mounted in a plate at least one-stud-diameter thick, at maximum stud extension (2:1 safety factor). Jig Feet Leveling Assemblies are rated with the standard plate provided.

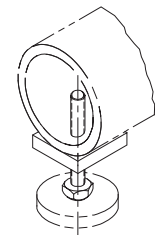

INCH

PART NO.	THREAD SIZE	A	C	D	E	F	H	*LOAD RATING (LBS)
CL-1-JF	3/8-16	3	11/16	1/2	1-1/2	1-3/4	.42	2,300
CL-2-JF	1/2-13	4	7/8	1/2	1-3/4	2	.53	4,200
CL-3-JF	5/8-11	4	1-1/16	5/8	2	2	.63	6,600
CL-4-JF	3/4-10	4	1-1/4	5/8	2	2	.75	10,000
CL-5-JF	1"-8	5	1-5/8	3/4	2	2	1.06	18,000

METRIC

PART NO.	THREAD SIZE	THREAD PITCH (mm)	A (mm)	C (mm)	D (mm)	E (mm)	F (mm)	H (mm)	LOAD RATING (kg)
CLM-10-JF	M10	1.5	75	17	12.5	38	44.5	11	1100
CLM-12-JF	M12	1.75	100	19	12.5	44.5	51	14	1700
CLM-16-JF	M16	2	100	24	16	51	51	16	3200
CLM-20-JF	M20	2.5	100	30	16	51	51	19	4900
CLM-24-JF	M24	3	130	36	19	51	51	27	7200

LEVELING FEET

STEEL: 1215, CARBURIZED-HARDENED (BODY ONLY), ZINC PLATED YELLOW CHROMATE OR BLACK OXIDE FINISH
 STAINLESS STEEL: 300 SERIES. DELRIN® PAD: WHITE DELRIN® 500.

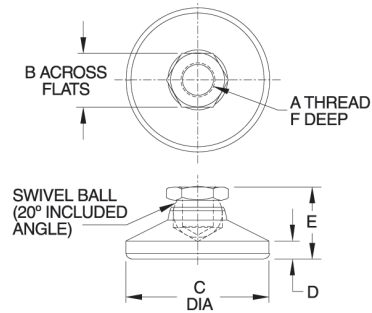

High-quality, heavy-duty leveling foot with large-diameter pad. Large ball provides high load capacity with a 20° total swivel angle.

5

INCH

PART NO. STEEL ZINC PLATED	PART NO. STEEL ZINC PLATED DELRIN® PAD	PART NO. STEEL BLACK OXIDE	PART NO. STAINLESS	PART NO. STAINLESS DELRIN® PAD	A	B	C DIA	D	E	F	LOAD RATING (LBS)*	
											STEEL & STAINLESS	DELRIN®
CL-3-LF	CL-3-LFN	CL-3-LF-BO	CL-3-LF-S	CL-3-LFN-S	#10-32	3/8	3/4	7/64	17/32	1/4	700	150
CL-4-LF	CL-4-LFN	CL-4-LF-BO	CL-4-LF-S	CL-4-LFN-S	1/4-20	1/2	1	5/32	45/64	5/16	1,000	200
CL-5-LF	CL-5-LFN	CL-5-LF-BO	CL-5-LF-S	CL-5-LFN-S	5/16-18	9/16	1-1/8	3/16	3/16	3/8	1,500	250
CL-6-LF	CL-6-LFN	CL-6-LF-BO	CL-6-LF-S	CL-6-LFN-S	3/8-16	5/8	1-1/4	3/16	7/8	13/32	2,300	300
CL-8-LF	CL-8-LFN	CL-8-LF-BO	CL-8-LF-S	CL-8-LFN-S	1/2-13	3/4	1-7/8	1/4	1-1/8	1/2	4,200	700
CL-10-LF	CL-10-LFN	CL-10-LF-BO	CL-10-LF-S	CL-10-LFN-S	5/8-11	15/16	2-1/2	5/16	1-1/4	1/2	6,600	1,200
CL-12-LF	CL-12-LFN	CL-12-LF-BO	CL-12-LF-S	CL-12-LFN-S	3/4-10	1-1/8	3	1/2	1-1/2	5/8	10,000	1,800
CL-16-LF	—	CL-16-LF-BO	CL-16-LF-S	—	1"-8	1-1/2	4	13/32	1-7/8	15/16	18,000	

METRIC

PART NO.	A THREAD	THREAD PITCH (mm)	B (mm)	C DIA (mm)	D (mm)	E (mm)	F (mm)	LOAD RATING Steel & Stainless Steel(kg)	LOAD RATING Delrin Pad(kg)
CLM-6-LF	M6	1	13	25.5	4	18	8	400	90
CLM-8-LF	M8	1.25	13	28.5	4.8	20.5	9.5	700	110
CLM-10-LF	M10	1.5	17	32	5	22	10.5	1200	140
CLM-12-LF	M12	1.75	19	47.5	6.5	28.5	12.5	1700	320
CLM-16-LF	M16	2	24	63.5	8	32	12.5	3300	550
CLM-20-LF	M20	2.5	30	76	12.5	38	16	5000	800

*Safe static load with stud securely mounted in a plate at least one-stud-diameter thick, at maximum stud extension (2:1 safety factor). Leveling Feet are rated with the same-length stud as on Stud Leveling Feet. Load capacity will drop significantly with longer studs.

Rubber Pad Covers fit over the bottom of Leveling Feet. These pad covers provide increased gripping to prevent sliding on sloped or uneven surfaces. They reduce walking and transmitted machine vibrations. Durable PVC material. Note: load capacity will be reduced with Rubber Pad Covers. See table below.

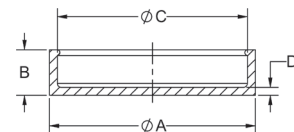

Rubber Pad Covers
for Leveling Feet



RUBBER PAD COVERS

PART NO.	FITS LEVELING FEET	A DIA	B	C DIA	D	LOAD RATING (LBS)
CL-6-RPC	3/8-16 and M10	1-1/2	.40	1.22	1/8	300
CL-8-RPC	1/2-13 and M12	2-1/8	.46	1.85		700
CL-10-RPC	5/8-11 and M16	2-3/4	.52	2.47		1,200
CL-12-RPC	3/4-10 and M20	3-1/4	.72	3.00		1,800

STUD LEVELING FEET

STEEL: 1215, CARBURIZED-HARDENED (BODY ONLY), ZINC PLATED YELLOW CHROMATE OR BLACK OXIDE FINISH
 STAINLESS STEEL: 300 SERIES. DELRIN® PAD: WHITE DELRIN® 500.



**Steel
Zinc Plated**



**Steel
Zinc Plated
with Delrin® Pad**



**Steel
Black Oxide Finish**



Stainless Steel



**Stainless Steel
with Delrin® Pad**

High-quality, heavy-duty leveling foot with large-diameter pad and integral stud. Stud and ball are one solid piece. Large ball provides high load capacity with a 20° total swivel angle.

* Safe static load with stud securely mounted in a plate at least one-stud-diameter thick, at maximum stud extension (2:1 safety factor). Load capacity will drop significantly with longer studs.

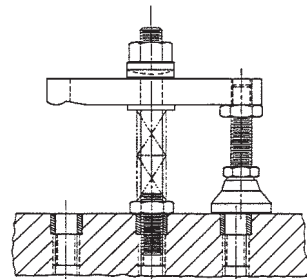

Can also be used as a clamp rest for Tapped-Heel Clamp Straps.

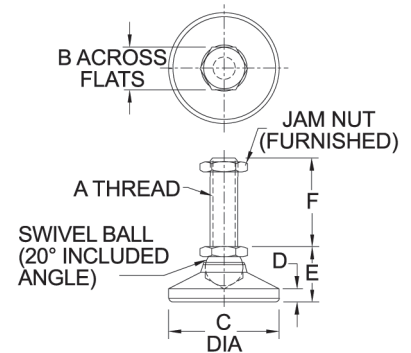

INCH

PART NO. STEEL ZINC PLATED	PART NO. STEEL ZINC PLATED DELRIN® PAD	PART NO. STEEL BLACK OXIDE	PART NO. STAINLESS	PART NO. STAINLESS DELRIN® PAD	A	B	C DIA	D	E	F	LOAD RATING (LBS)*	
											STEEL & STAINLESS	DELRIN®
CL-3-SLF	CL-3-SLFN	CL-3-SLF-BO	CL-3-SLF-S	CL-3-SLFN-S	#10-32	3/8	3/4	7/64	17/32	1	700	150
CL-3-SLF-2	CL-3-SLFN-2	CL-3-SLF-2-BO	CL-3-SLF-2-S	CL-3-SLFN-2-S						2	200	
CL-4-SLF	CL-4-SLFN	CL-4-SLF-BO	CL-4-SLF-S	CL-4-SLFN-S	1/4-20	1/2	1	5/32	45/64	1-1/4	1,000	200
CL-4-SLF-2.5	CL-4-SLFN-2.5	CL-4-SLF-2.5-BO	CL-4-SLF-2.5-S	CL-4-SLFN-2.5-S						2-1/2	250	
CL-5-SLF	CL-5-SLFN	CL-5-SLF-BO	CL-5-SLF-S	CL-5-SLFN-S	5/16-18	9/16	1-1/8	3/16	13/16	2	1,500	250
CL-5-SLF-4	CL-5-SLFN-4	CL-5-SLF-4-BO	CL-5-SLF-4-S	CL-5-SLFN-4-S						4	400	
CL-6-SLF	CL-6-SLFN	CL-6-SLF-BO	CL-6-SLF-S	CL-6-SLFN-S	3/8-16	5/8	1-1/4	3/16	7/8	2	2,300	300
CL-6-SLF-4	CL-6-SLFN-4	CL-6-SLF-4-BO	CL-6-SLF-4-S	CL-6-SLFN-4-S						4	600	
CL-8-SLF	CL-8-SLFN	CL-8-SLF-BO	CL-8-SLF-S	CL-8-SLFN-S	1/2-13	3/4	1-7/8	1/4	1-1/8	2	4,200	700
CL-8-SLF-4	CL-8-SLFN-4	CL-8-SLF-4-BO	CL-8-SLF-4-S	CL-8-SLFN-4-S						4	1100	
CL-10-SLF	CL-10-SLFN	CL-10-SLF-BO	CL-10-SLF-S	CL-10-SLFN-S	5/8-11	15/16	2-1/2	5/16	1-1/4	2	6,600	1,200
CL-10-SLF-4	CL-10-SLFN-4	CL-10-SLF-4-BO	CL-10-SLF-4-S	CL-10-SLFN-4-S						4	1700	
CL-12-SLF	CL-12-SLFN	CL-12-SLF-BO	CL-12-SLF-S	CL-12-SLFN-S	3/4-10	1-1/8	3	1/2	1-1/2	2	10,000	1,800
CL-12-SLF-4	CL-12-SLFN-4	CL-12-SLF-4-BO	CL-12-SLF-4-S	CL-12-SLFN-4-S						4	2500	
CL-16-SLF	—	CL-16-SLF-BO	CL-16-SLF-S	—	1"-8	1-1/2	4	13/32	1-7/8	4-1/4	18,000	—
CL-16-SLF-8	—	CL-16-SLF-8-BO	CL-16-SLF-8-S	—						8	4500	

METRIC

PART NO.	A THREAD	THREAD PITCH (mm)	B (mm)	C DIA (mm)	D (mm)	E (mm)	F (mm)	LOAD RATING Steel & Stainless Steel(kg)	LOAD RATING Derlin(kg)
CLM-6-SLF	M6	1	10	25.5	4	18	40	400	90
CLM-8-SLF	M8	1.25	13	28.5	4.8	20.5	50	700	110
CLM-10-SLF	M10	1.5	17	32	5	22	51	1200	140
CLM-12-SLF	M12	1.75	19	47.5	6.5	28.5	51	1700	320
CLM-16-SLF	M16	2	24	63.5	8	32	51	3300	550
CLM-20-SLF	M20	2.5	30	76	12.5	38	51	5000	800

SWIVEL PAD FEET

STEEL PAD: 1215 STEEL, ZINC PLATED YELLOW CHROMATE OR BLACK OXIDE FINISH

DELRIN® PAD: WHITE DELRIN 500. STAINLESS PAD: 300-SERIES STAINLESS STEEL

STEEL NUT: 1215 STEEL, CARBURIZED-HARDENED ZINC PLATED YELLOW CHROMATE OR BLACK OXIDE FINISH

STAINLESS NUT: 300-SERIES STAINLESS STEEL



**Steel
Zinc Plated**



**Steel
Zinc Plated
with Delrin® Pad**



**Steel
Black Oxide Finish**

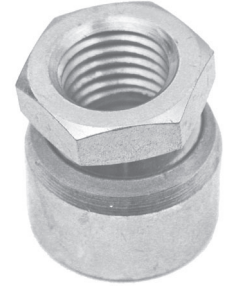

**Stainless
Steel**

5

Heavy-duty swivel foot pivots to contact sloped surfaces evenly. Large ball provides high load capacity with a 20° total swivel angle. Available in steel (zinc plated or black oxide finish), steel with a Delrin® pad, and stainless steel.

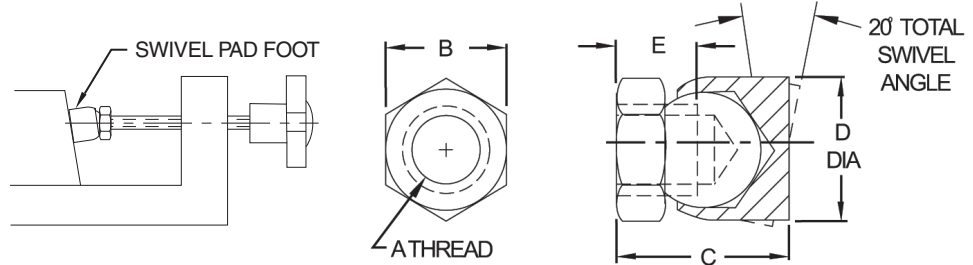

STEEL — ZINC PLATED (INCH)

PART NO.	A	B	C	D DIA	E
CL-4-SPF	1/4-20	1/2	5/8	5/8	5/16
CL-5-SPF	5/16-18	9/16	3/4	11/16	3/8
CL-6-SPF	3/8-16	5/8	13/16	3/4	
CL-8-SPF	1/2-13	3/4	15/16	7/8	7/16
CL-10-SPF	5/8-11	7/8	1	1	
CL-12-SPF	3/4-10	1-1/16	1-11/32	1-1/4	5/8

SSTEEL — ZINC PLATED WITH DELRIN® PAD (INCH)

PART NO.	A	B	C	D DIA	E
CL-4-SPFN	1/4-20	1/2	5/8	5/8	5/16
CL-5-SPFN	5/16-18	9/16	3/4	11/16	3/8
CL-6-SPFN	3/8-16	5/8	13/16	3/4	
CL-8-SPFN	1/2-13	3/4	15/16	7/8	7/16
CL-10-SPFN	5/8-11	7/8	1	1	
CL-12-SPFN	3/4-10	1-1/16	1-11/32	1-1/4	5/8

STEEL — BLACK OXIDE FINISH (INCH)

PART NO.	A	B	C	D DIA	E
CL-4-SPF-BO	1/4-20	1/2	5/8	5/8	5/16
CL-5-SPF-BO	5/16-18	9/16	3/4	11/16	3/8
CL-6-SPF-BO	3/8-16	5/8	13/16	3/4	
CL-8-SPF-BO	1/2-13	3/4	15/16	7/8	7/16
CL-10-SPF-BO	5/8-11	7/8	1	1	
CL-12-SPF-BO	3/4-10	1-1/16	1-11/32	1-1/4	5/8

STAINLESS STEEL (INCH)

PART NO.	A	B	C	D DIA	E
CL-4-SPF-S	1/4-20	1/2	5/8	5/8	5/16
CL-5-SPF-S	5/16-18	9/16	3/4	11/16	3/8
CL-6-SPF-S	3/8-16	5/8	13/16	3/4	
CL-8-SPF-S	1/2-13	3/4	15/16	7/8	7/16
CL-10-SPF-S	5/8-11	7/8	1	1	
CL-12-SPF-S	3/4-10	1-1/16	1-11/32	1-1/4	5/8

STEEL — ZINC PLATED (METRIC)

PART NO.	A THREAD	THREAD PITCH (mm)	B (mm)	C (mm)	D DIA (mm)	E (mm)
CLM-6-SPF	M6	1	13	16	16	8
CLM-8-SPF	M8	1.25	15	19	17.5	9.5
CLM-10-SPF	M10	1.5	17	20.5	19	9.5
CLM-12-SPF	M12	1.75	19	24	22	11
CLM-16-SPF	M16	2	24	25.5	25.5	11
CLM-20-SPF	M20	2.5	30	34	32	16

STEEL — ZINC PLATED WITH DELRIN® PAD (METRIC)

PART NO.	A THREAD	THREAD PITCH (mm)	B (mm)	C (mm)	D DIA (mm)	E (mm)
CLM-6-SPFN	M6	1	13	16	16	8
CLM-8-SPFN	M8	1.25	15	19	17.5	9.5
CLM-10-SPFN	M10	1.5	17	20.5	19	9.5
CLM-12-SPFN	M12	1.75	19	24	22	11
CLM-16-SPFN	M16	2	24	25.5	25.5	11
CLM-20-SPFN	M20	2.5	30	34	32	16

STEEL — BLACK OXIDE FINISH (METRIC)

PART NO.	A THREAD	THREAD PITCH (mm)	B (mm)	C (mm)	D DIA (mm)	E (mm)
CLM-6-SPF-BO	M6	1	13	16	16	8
CLM-8-SPF-BO	M8	1.25	15	19	17.5	9.5
CLM-10-SPF-BO	M10	1.5	17	20.5	19	9.5
CLM-12-SPF-BO	M12	1.75	19	24	22	11
CLM-16-SPF-BO	M16	2	24	25.5	25.5	11
CLM-20-SPF-BO	M20	2.5	30	34	32	16

STEEL — ZINC PLATED WITH DELRIN® PAD (METRIC)

PART NO.	A THREAD	THREAD PITCH (mm)	B (mm)	C (mm)	D DIA (mm)	E (mm)
CLM-6-SPF-S	M6	1	13	16	16	8
CLM-8-SPF-S	M8	1.25	15	19	17.5	9.5
CLM-10-SPF-S	M10	1.5	17	20.5	19	9.5
CLM-12-SPF-S	M12	1.75	19	24	22	11
CLM-16-SPF-S	M16	2	24	25.5	25.5	11
CLM-20-SPF-S	M20	2.5	30	34	32	16

SWIVEL PADS

PAD: 1215 STEEL, CARBURIZED-HARDENED, BLACK OXIDE FINISH OR DELRIN®
 NUT: 1215 STEEL, BLACK OXIDE FINISH



Heavy-duty swivel foot pivots to contact sloped surfaces evenly. Large ball provides high load capacity with a 18° total swivel angle. Choice of steel or Delrin® pad.

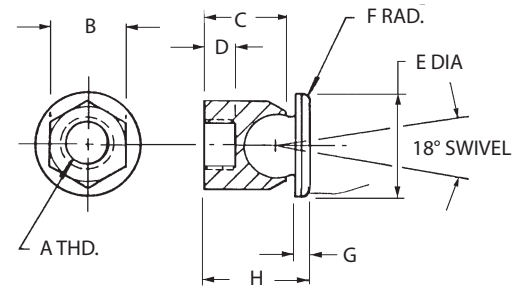

INCH

PART NO. STEEL PAD	PART NO. DELRIN® PAD	A	B	C	D	E DIA	F	G	H
CL-1-SPA	CL-1-SPAN	1/4-20	1/2	.50	.23	5/8	.06	.10	.67
CL-2-SPA	CL-2-SPAN	5/16-18	9/16	.58	.27	3/4			.75
CL-3-SPA	CL-3-SPAN	3/8-16	5/8	.71	.29	7/8	.09	.12	.91
CL-4-SPA	CL-4-SPAN	1/2-13	3/4	.81	.31	1			1.05
CL-5-SPA	CL-5-SPAN	5/8-11	7/8	1.00	.35	1-1/8	.15	.20	1.25
CL-6-SPA	—	3/4-10	1-1/16	1.12		1-1/4			1.38
CL-7-SPA	—	1-8	1-3/8	1.50		1-5/8			1.82

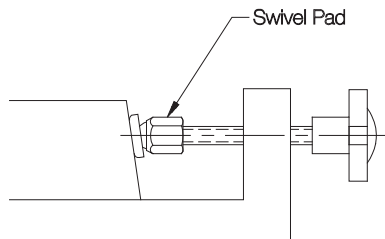

METRIC

PART NO.	A THREAD	THREAD PITCH (mm)	B (mm)	C (mm)	D (mm)	E DIA (mm)	F (mm)	G (mm)	H (mm)
CLM-6-SPA	M6	1	10	14	6	12.5	1	2	17
CLM-8-SPA	M8	1.25	13	14.5	5.5	19	1.5	2.5	19
CLM-10-SPA	M10	1.5	17	18	7.5	22	1.5	3	23
CLM-12-SPA	M12	1.75	19	20.5	8	25.5	2.5	4	26.5
CLM-16-SPA	M16	2	24	25.5	9	28.5	2.5	4	32
CLM-20-SPA	M20	2.5	30	28.5	9	32	2.5	4	35

SWIVEL NUTS

NUT: 1215 STEEL, CARBURIZED-HARDENED, BLACK OXIDE FINISH
 PAD: 1215 STEEL, BLACK OXIDE FINISH



Nut turns freely without pivoting while pad remains stationary, to avoid moving or marring the workpiece.

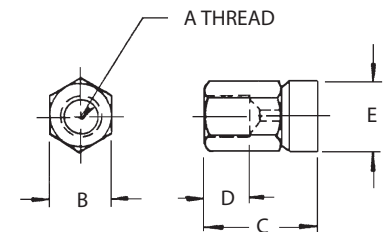

INCH

PART NO.	A	B	C	D	E DIA
CL-4-SN	1/4-20	5/16	7/16	3/16	3/8
CL-5-SN	5/16-18	3/8	17/32	1/4	7/16
CL-6-SN	3/8-16	7/16	17/32	17/64	1/2
CL-8-SN	1/2-13	5/8	21/32	3/8	11/16
CL-10-SN	5/8-11	3/4	17/32	7/16	7/8
CL-12-SN	3/4-10	7/8	1	1/2	1

METRIC

PART NO.	A	B	C	D	E DIA
CLM-6-SN	M6	8mm	.43	3/16	.39
CLM-10-SN	M10	13mm	.55	17/64	.51
CLM-12-SN	M12	17mm	.67	3/8	.71

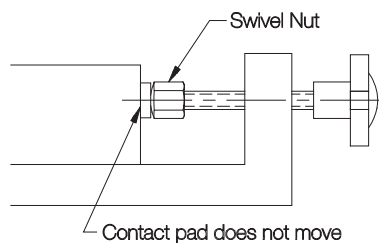

ROUND GRIPPERS

HARDENED TOOL STEEL: M-2 TOOL STEEL, HEAT TREATED RC 60-62, BLACK OXIDE FINISH

CARBIDE TIPPED: ALLOY STEEL, HEAT TREATED, WITH BRAZED CARBIDE INSERT, BLACK OXIDE FINISH

SOLID CARBIDE: CARBIDE WITH STEEL THREAD INSERT

ABRASIVE DIAMOND: 17-4PH STAINLESS STEEL, HEAT TREATED RC 43-46, WITH FUSED ABRASIVE DIAMOND SURFACE

BONDED URETHANE: 300-SERIES STAINLESS STEEL WITH BONDED URETHANE SURFACE

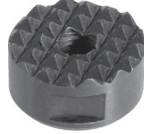

Hardened Tool Steel (Serrated)



Carbide Tipped (Serrated)

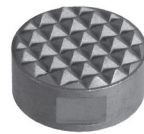

Solid Carbide (Serrated)

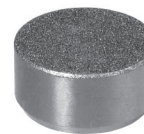

Abrasive Diamond



Bonded Urethane

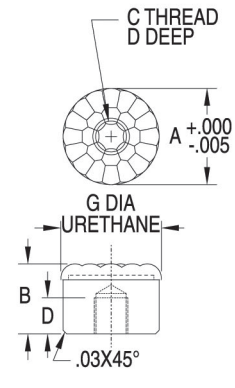
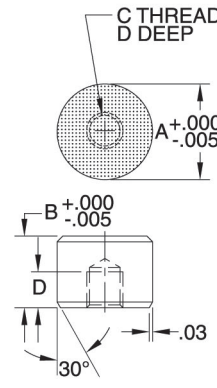
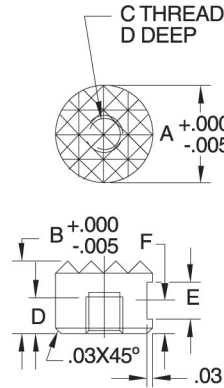
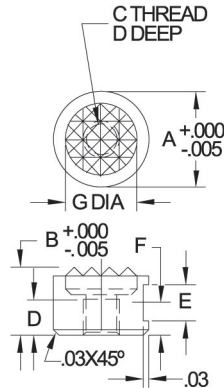
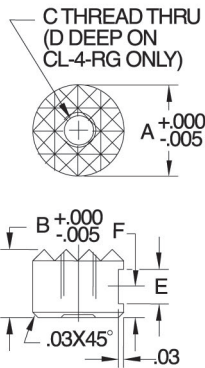

Round Grippers are replaceable inserts that provide additional holding force and/or wear resistance when installed in a fixture. Fasten from behind with a socket-head cap screw, or clamp with a setscrew on the O.D. locking flat (where provided). Grippers can be recess-mounted in a flat-bottom hole, or surface mounted to use as a rest pad. Round Grippers can also be installed in Gripper Swivel Pads and Gripper Swivel Contact Bolts.

Serrated grippers are designed to slightly penetrate the workpiece to significantly increase gripping force, rather than relying on static friction alone. The hardened-tool-steel version is the most economical and impact resistant. The carbide-tipped version is still economical and impact resistant while providing extra durability. The solid-carbide version is the most durable.

Abrasive-diamond grippers have an abrasive-diamond surface permanently fused to a hardened stainless steel pad. This abrasive surface, comparable to a 100-grit abrasive, provides significant holding force with relatively low clamping pressure and minimal surface marring. This diamond-particle surface also offers excellent wear resistance.

Bonded-urethane grippers have a urethane surface permanently bonded to a stainless steel pad. This non-marking, non-staining urethane provides excellent protection against damage to finished workpieces. The bubbled texture of the urethane surface offers firm gripping, yet allows air to escape so that no suction is created under load. Urethane also provides excellent wear resistance, and is available in three firmnesses to suit a wide variety of applications.

INCH

PART NO. HARDENED TOOL STEEL (SERRATED)	PART NO. CARBIDE TIPPED (SERRATED)	PART NO. SOLID CARBIDE (SERRATED)	PART NO. ABRASIVE DIAMOND	A DIA	B	C	D	E	F	G DIA	SERRATIONS	PART NO. BONDED URETHANE	URETHANE			
													B	D	G DIA	
CL-4-RG	—	—	—	1/4	3/8	#8-32	3/16	—	—	—	Extra Fine	—	—	—		
CL-6-RG	CL-6-RGT	—	CL-6-RGD	3/8		#10-32		3/16	11/64	5/16	.094x90°	CL-6-RGU-1*	1/2	1/4	.39	
CL-8-RG	CL-8-RGT	CL-8-RGC	CL-8-RGD	1/2		3/8				CL-8-RGU-1*		.51				
CL-10-RG	CL-10-RGT	CL-10-RGC	CL-10-RGD	5/8		1/2				CL-10-RGU-1*		.63				
CL-12-RG	CL-12-RGT	CL-12-RGC	CL-12-RGD	3/4		1/4-28		3/16	11/64	5/8		.125x90°	CL-12-RGU-1*	3/8	3/8	.83
CL-16-RG	CL-16-RGT	—	CL-16-RGD	1						3/4			CL-16-RGU-1*			1.06

METRIC

PART NO.	A DIA (mm)	B (mm)	C THREAD	THREAD PITCH (mm)	D (mm)	E (mm)	F (mm)	SERRATIONS	SERRATION DIMENSIONS (mm)
CLM-10-RG	10	10	M5	.8	5	4.7	4.5	EXTRA FINE	2.4x90°
CLM-12-RG	12	10	M5	.8	5	4.7	4.5	FINE	3.2x90°
CLM-16-RG	16	10	M6	1	5	4.7	4.5	FINE	3.2x90°
CLM-20-RG	20	10	M6	1	5	4.7	4.5	FINE	3.2x90°
CLM-25-RG	25	10	M6	1	5	4.7	4.5	FINE	3.2x90°

ROUND GRIPPERS

CARBIDE TIPPED: ALLOY STEEL, HEAT TREATED, WITH BRAZED CARBIDE INSERT, BLACK OXIDE FINISH
 HARDENED STEEL: 8620 STEEL, CARBURIZED-HARDENED, BLACK OXIDE FINISH
 HARDENED STAINLESS STEEL: 17-4 STAINLESS STEEL, HEAT TREATED RC 43-46
 DELRIN®: WHITE DELRIN® 500



Carbide Tipped (Flat)



Hardened Steel (Flat)

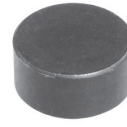

Hardened Stainless Steel (Flat)



Delrin® (Flat)

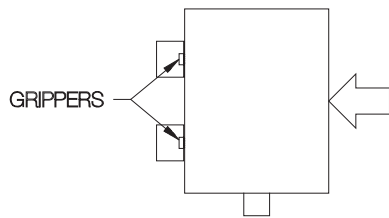
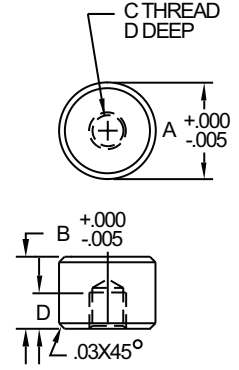
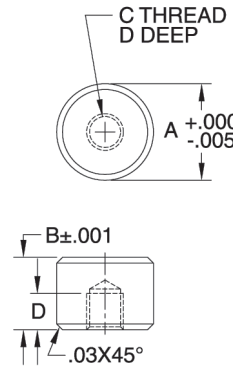
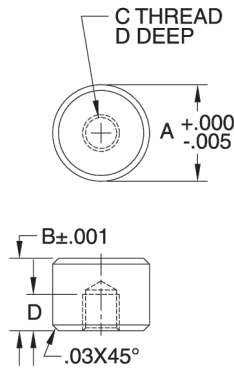
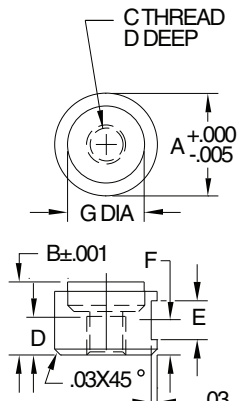

Serrated grippers recessed into a fixture's locating surfaces dramatically increase resistance to movement by embedding themselves in the workpiece.

Flat grippers can be used to provide additional wear resistance, or as precision rest pads. The carbide-tipped version is the most durable. The hardened-steel version is the most economical and impact resistant. The hardened-stainless-steel version provides high strength and excellent corrosion resistance. The Delrin® version helps avoid marring finished workpieces.

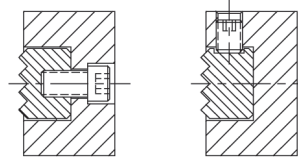

Round Grippers can be fastened from behind with a Socket-Head Cap Screw. Some gripper types also have an O.D. locking flat for fastening with a set screw.

INCH

PART NO. CARBIDE TIPPED (FLAT)	PART NO. HARDENED STEEL (FLAT)	PART NO. HARDENED STAINLESS (FLAT)	PART NO. DELRIN® (FLAT)	A DIA	B	C	D	E	F	G DIA
CL-6-RGFT	CL-6-RGF	CL-6-RGF-S	CL-6-RGFN	3/8	3/8	#10-32	3/8	3/16	11/64	5/16
CL-8-RGFT	CL-8-RGF	CL-8-RGF-S	CL-8-RGFN	1/2						3/8
CL-10-RGFT	CL-10-RGF	CL-10-RGF-S	CL-10-RGFN	5/8		1/4-28				5/8
CL-12-RGFT	CL-12-RGF	CL-12-RGF-S	CL-12-RGFN	3/4						3/4
CL-16-RGFT	CL-16-RGF	CL-16-RGF-S	CL-16-RGFN	1						1

METRIC

PART NO.	A DIA (mm)	B (mm)	C THREAD	THREAD PITCH (mm)	D (mm)	E (mm)	F (mm)	SERRATIONS	SERRATION DIMENSIONS (mm)
CLM-10-RGF	10	10	M5	.8	5	4.7	4.5	EXTRA FINE	2.4x90°
CLM-12-RGF	12	10	M5	.8	5	4.7	4.5	FINE	3.2x90°
CLM-16-RGF	16	10	M6	1	5	4.7	4.5	FINE	3.2x90°
CLM-20-RGF	20	10	M6	1	5	4.7	4.5	FINE	3.2x90°
CLM-25-RGF	25	10	M6	1	5	4.7	4.5	FINE	3.2x90°

ROUND GRIPPERS (COUNTERBORED)

HARDENED TOOL STEEL: M-2 TOOL STEEL, HEAT TREATED RC 60-62, BLACK OXIDE FINISH

ABRASIVE DIAMOND: 17-4 STAINLESS STEEL, HEAT TREATED RC 43-46, WITH ABRASIVE DIAMOND SURFACE



Hardened Tool Steel (Serrated)



Abrasive Diamond

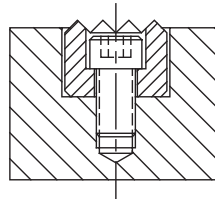
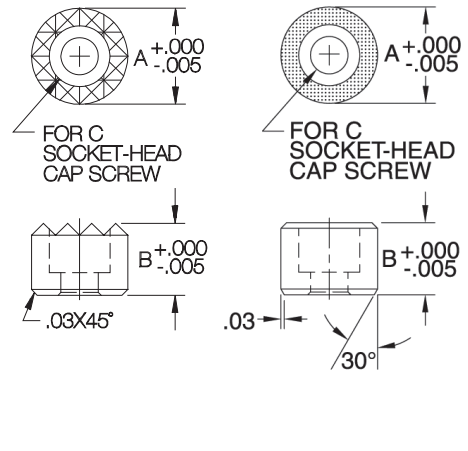

INCH

PART NO. HARDENED TOOL STEEL (SERRATED)	PART NO. DIAMOND ABRASIVE	A DIA	B	C	SERRATIONS (HARDENED TOOL STEEL VERSION)	
CL-8-RGB	CL-8-RGBD	1/2	3/8	#8	Fine	.125x90°
CL-10-RGB	CL-10-RGBD	5/8				
CL-12-RGB	CL-12-RGBD	3/4	1/2	#10		
CL-16-RGB	CL-16-RGBD	1		1/4		

METRIC

CLM-12-RGB	CLM-12-RGBD	12mm	10mm	M4	Fine	3.2x90°
CLM-16-RGB	CLM-16-RGBD	16mm				
CLM-20-RGB	CLM-20-RGBD	20mm	12mm	M5		
CLM-25-RGB	CLM-25-RGBD	25mm		M6		

Counterbored Round Grippers are ideal for blind-hole installation and surface mounting. Fasten with a standard socket-head cap screw. The serrated version, made of hardened tool steel, is designed to slightly penetrate the workpiece to significantly increase gripping force. The abrasive-diamond version has an abrasive-diamond surface permanently fused to a hardened stainless steel pad. This abrasive surface, comparable to a 100-grit abrasive, provides significant holding force with relatively low clamping pressure and minimal surface marring. This diamond-particle surface also offers excellent wear resistance.

SQUARE GRIPPERS (COUNTERBORED)

M-2 TOOL STEEL, HEAT TREATED RC 60-62, BLACK OXIDE FINISH

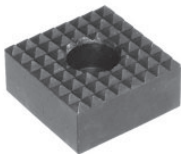

Hardened Tool Steel (Serrated)

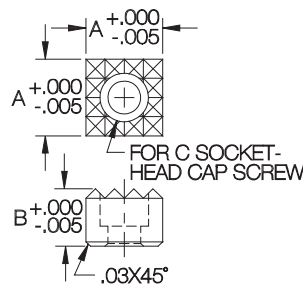

COUNTERBORED (INCH)

PART NO. HARDENED TOOL STEEL (SERRATED)	A	B	C	SERRATIONS	
CL-8-SGB	1/2	1/2	#10	Fine	.125x90°
CL-12-SGB	3/4		1/4		
CL-16-SGB	1				

COUNTERBORED (METRIC)

CLM-12-SGB	12mm	12mm	M4	Fine	3.2x90°
CLM-20-SGB	20mm		M5		
CLM-25-SGB	25mm	M6			

Counterbored Round Grippers are ideal for blind-hole installation and surface mounting. Fasten with a standard socket-head cap screw.

SQUARE GRIPPERS

HARDENED TOOL STEEL: M-2 TOOL STEEL, HEAT TREATED RC 60-62, BLACK OXIDE FINISH
 CARBIDE TIPPED: ALLOY STEEL, HEAT TREATED, WITH BRAZED CARBIDE INSERT, BLACK OXIDE FINISH
 SOLID CARBIDE: CARBIDE WITH STEEL THREAD INSERT

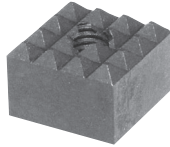

**Hardened
Tool Steel
(Serrated)**

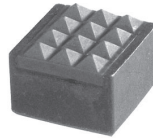

**Carbide
Tipped
(Serrated)**

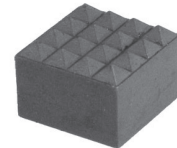

**Solid
Carbide
(Serrated)**

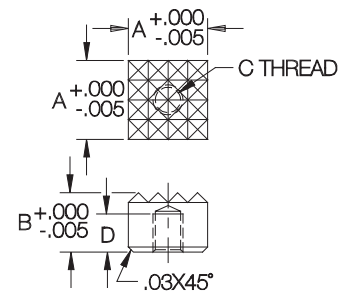
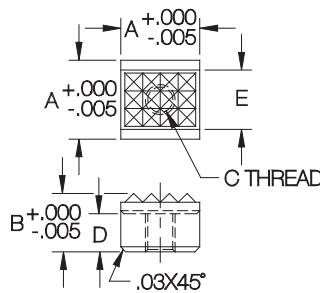
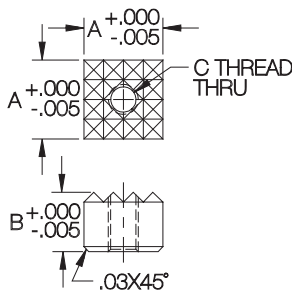

Square Grippers are similar to Round Grippers, but their shape is useful when positive resistance to rotation is required (they can be mounted against a step to prevent rotation). These serrated grippers are hard, replaceable inserts that provide additional holding force and/or wear resistance when installed in a fixture. They are designed to slightly penetrate the workpiece to significantly increase gripping force, rather than relying on static friction alone. The hardened-tool-steel version is the most economical and impact resistant. The carbide-tipped version is still economical and impact resistant while providing extra durability. The solid-carbide version is the most durable.

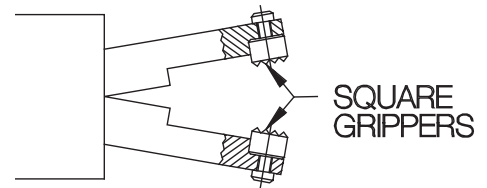

Square Grippers can be mounted against a step for positive resistance to rotation.

INCH

PART NO. HARDENED TOOL STEEL (SERRATED)	PART NO. CARBIDE TIPPED (SERRATED)	PART NO. SOLID CARBIDE (SERRATED)	A	B	C	SERRATIONS	
CL-6-SG	—	—	3/8	3/8	#10-32	XFine	.094x90°
CL-8-SG	CL-8-SGT	CL-8-SGC	1/2			Fine	.125x90°
CL-12-SG	—	—	3/4		1/4-28		
CL-16-SG	—	—	1				

INCH

CLM-10-SG	CLM-12-SG	CLM-12-SGT	CLM-20-SG	CLM-25-SG	A	B	C	SERRATIONS	
—	—	—	—	—	10mm	10mm	M5	XFine	2.4x90°
—	—	—	—	—	12mm			Fine	3.2x90°
—	—	—	—	—	20mm		M6		
—	—	—	—	—	25mm				

EDGE GRIPPERS

M-2 TOOL STEEL, HEAT TREATED RC 60-62, BLACK OXIDE FINISH

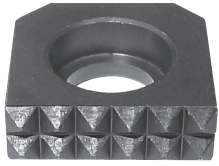

**Serrated
Hardened Tool Steel**

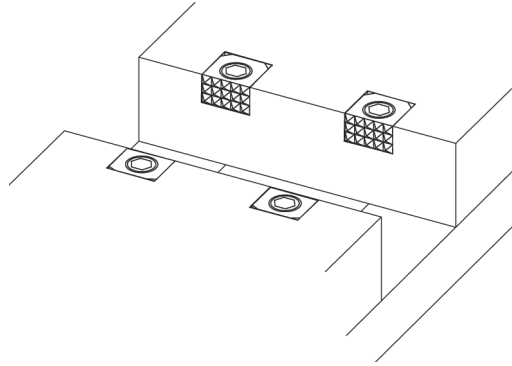

Edge Grippers are ideal for mounting at the top edge of a clamping face such as a vise jaw.

Edge Grippers are helpful for applications where traditional face-mounted grippers are difficult to install. They have a useful flat profile because the mounting screw is parallel to the serrated face. These serrated grippers are hard, replaceable inserts used to provide additional holding force and/or wear resistance when installed in a fixture. They are designed to slightly penetrate the workpiece to significantly increase gripping force, rather than relying on static friction alone. Edge Grippers should be mounted in a flat-bottom recess that provides support behind the gripper. Fasten with a standard socket-head cap screw (on the largest three sizes, a low-head cap screw is required). The serrated face should project 50 to 100% of serration height for maximum effectiveness (serration height is .062" on grippers with fine serrations, .047" on grippers with extra-fine serrations, and .031" on grippers with super-fine serrations).

INCH

PART NO.	A	B	SERRATIONS		C	COUNTERBORE DEPTH	D
CL-6-EG-4	3/8	1/4	Extra Fine	.094x90°	#6	.146	1/16
CL-6-EG-4-SF			Super Fine	.062x90°			
CL-6-EG-6		3/8	Extra Fine	.094x90°			
CL-6-EG-6-SF			Super Fine	.062x90°			
CL-8-EG-4	1/2	1/4	Fine	.125x90°	#8	.170	3/32
CL-8-EG-4-EF			Extra Fine	.094x90°			
CL-8-EG-6		3/8	Fine	.125x90°		.175	
CL-8-EG-6-EF			Extra Fine	.094x90°			
CL-8-EG-8		1/2	Fine	.125x90°			
CL-8-EG-8-EF			Extra Fine	.094x90°			
CL-10-EG-4	5/8	1/4	Fine	.125x90°	1/4 LHCS	.130	1/8
CL-10-EG-4-EF			Extra Fine	.094x90°			
CL-10-EG-6		3/8	Fine	.125x90°			
CL-10-EG-6-EF			Extra Fine	.094x90°			
CL-10-EG-8		1/2	Fine	.125x90°			
CL-10-EG-8-EF			Extra Fine	.094x90°			
CL-12-EG-4	3/4	1/4	Fine	.125x90°	5/16 LHCS	.161	1/8
CL-12-EG-4-EF			Extra Fine	.094x90°			
CL-12-EG-6		3/8	Fine	.125x90°			
CL-12-EG-6-EF			Extra Fine	.094x90°			
CL-12-EG-8		1/2	Fine	.125x90°			
CL-12-EG-8-EF			Extra Fine	.094x90°			
CL-16-EG-6	1	3/8	Fine	.125x90°	3/8 LHCS	.194	1/8
CL-16-EG-6-EF			Extra Fine	.094x90°			
CL-16-EG-8		1/2	Fine	.125x90°			
CL-16-EG-8-EF			Extra Fine	.094x90°			

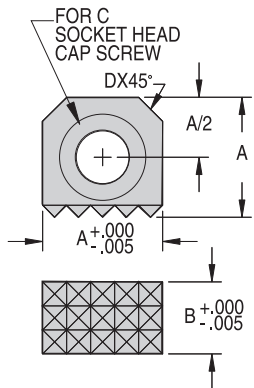

METRIC

CLM-10-EG-6	10mm	6mm	Extra Fine	2.4x90°	M3 or #6	3.8	1.6
CLM-10-EG-10		10mm					
CLM-12-EG-6	12mm	6mm	Fine	3.2x90°	M4 or #8	4.1	2.3
CLM-12-EG-10		10mm					
CLM-12-EG-12		12mm					
CLM-16-EG-6	16mm	6mm	Fine	3.2x90°	M6 or 1/4 LHCS	4.2	3.2
CLM-16-EG-10		10mm					
CLM-16-EG-12		12mm					
CLM-20-EG-6	20mm	6mm	Fine	3.2x90°	M8 or 5/16 LHCS	5.1	3.2
CLM-20-EG-10		10mm					
CLM-20-EG-12		12mm					
CLM-25-EG-10	25mm	10mm	Fine	3.2x90°	M10 or 3/8 LHCS	6.1	3.2
CLM-25-EG-12		12mm					

GRIPPER CONTACT BOLTS

STEEL, CARBURIZED-HARDENED, BLACK OXIDE FINISH, WITH BRAZED CARBIDE GRIPPER



**Carbide Tipped
(Serrated)**

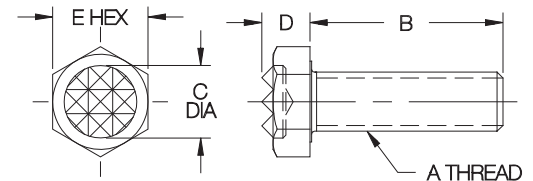

Fully threaded contact bolt with a carbide-tipped gripper head. Can be used as an adjustable support, or as a contact bolt in a clamp. Available in thread sizes from 1/4-20 to 5/8-11 (M6 to M16 in metric) each in a choice of lengths.

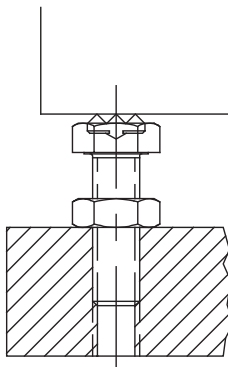

5

INCH

PART NO.	A	B	C DIA	D	E	SERRATIONS	
CL-405-GCB	1/4-20	1/2	5/16	13/64	7/16	Extra Fine	.094x90°
CL-410-GCB		1					
CL-505-GCB	5/16-18	1/2	3/8	1/4	1/2	Fine	.125x90°
CL-510-GCB		1					
CL-515-GCB		1-1/2					
CL-605-GCB	3/8-16	1/2	1/2	9/32	9/16	Fine	.125x90°
CL-610-GCB		1					
CL-615-GCB		1-1/2					
CL-810-GCB	1/2-13	1	5/8	23/64	3/4	Fine	.125x90°
CL-815-GCB		1-1/2					
CL-1010-GCB	5/8-11	1	3/4	7/16	15/16	Fine	.125x90°
CL-1020-GCB		2					

METRIC

PART NO.	A THREAD	THREAD PITCH (mm)	B (mm)	C DIA (mm)	D (mm)	E (mm)	SERRATIONS	SERRATION DIMENSIONS (mm)
CLM-625-GCB	M6	1	25	8	5	10	EXTRA FINE	2.4x90°
CLM-812-GCB	M8	1.25	12	9.5	6.4	13	FINE	3.2x90°
CLM-825-GCB	M8	1.25	25	9.5	6.4	13	FINE	3.2x90°
CLM-835-GCB	M8	1.25	35	9.5	6.4	13	FINE	3.2x90°
CLM-1012-GCB	M10	1.5	12	12.5	7.5	17	FINE	3.2x90°
CLM-1025-GCB	M10	1.5	25	12.5	7.5	17	FINE	3.2x90°
CLM-1040-GCB	M10	1.5	40	12.5	7.5	17	FINE	3.2x90°
CLM-1225-GCB	M12	1.75	25	16	8.7	19	FINE	3.2x90°
CLM-1240-GCB	M12	1.75	40	16	8.7	19	FINE	3.2x90°
CLM-1635-GCB	M16	2	35	19	11	24	FINE	3.2x90°
CLM-1650-GCB	M16	2	50	19	11	24	FINE	3.2x90°

GRIPPER SWIVEL CONTACT BOLTS

BODY AND GRIPPER SCREW: STEEL, CARBURIZED-HARDENED, BLACK OXIDE FINISH
 SWIVEL BALL: 440C STAINLESS STEEL, HEAT TREATED. O-RING: RUBBER



Hardened Tool Steel (Serrated)



Carbide Tipped (Serrated)



Solid Carbide (Serrated)



Abrasive Diamond



Bonded Urethane



Carbide Tipped (Flat)



Hardened Steel or Delrin® (Flat)

Threaded contact bolt with a built-in swivel ball to hold a Round Gripper. This swivel ball, held by a retaining ring, is removable to allow installing any of the eleven different gripper types (order gripper separately). A fastening screw is furnished with the contact bolt. This screw serves as a positive stop to prevent the ball from swiveling too far. Can be used as a contact bolt, or as a support. Available in thread sizes from 3/8-16 to 1"-8 (M10 to M24 in metric), most in a choice of several lengths.

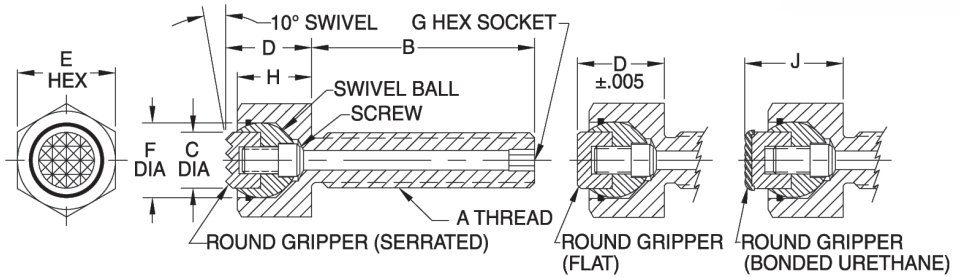

BODY AND GRIPPER — ORDER SEPARATELY (INCH)

PART NO. BODY WITHOUT GRIPPER	PART NO. — ROUND GRIPPER							A	B	C DIA	D	E	F DIA	G	H	J	SERRATIONS
	HARDENED TOOL STEEL (SERRATED)	CARBIDE TIPPED (SERRATED)	SOLID CARBIDE (SERRATED)	ABRASIVE DIAMOND	BONDED URETHANE	CARBIDE TIPPED (FLAT)	STEEL, SS, OR DELRIN® (FLAT)										
CL-605-GSB	CL-6-RG	CL-6-RGT	—	CL-6-RGD	CL-6-RGU-1	CL-6-RGFT	CL-6-RGF	3/8-16	1/2	3/8	5/8	5/8	1/2	1/8	1/2	3/4	Extra Fine .094x90°
CL-610-GSB					CL-6-RGU-2		CL-6-RGF-S										
CL-615-GSB					CL-6-RGU-3		CL-6-RGFN										
CL-810-GSB	CL-8-RG	CL-8-RGT	CL-8-RGC	CL-8-RGD	CL-8-RGU-1	CL-8-RGFT	CL-8-RGF	1/2-13	1	1/2	3/4	13/16	5/8	3/16	5/8	7/8	
CL-815-GSB					CL-8-RGU-2		CL-8-RGF-S										
					CL-8-RGU-3		CL-8-RGFN		1-1/2								
CL-1010-GSB	CL-10-RG	CL-10-RGT	CL-10-RGC	CL-10-RGD	CL-10-RGU-1	CL-10-RGFT	CL-10-RGF	5/8-11	1	5/8	13/16	15/16	3/4	1/4	11/16	15/16	
CL-1020-GSB					CL-10-RGU-2		CL-10-RGF-S										
					CL-10-RGU-3		CL-10-RGFN		2								
CL-1210-GSB	CL-12-RG	CL-12-RGT	CL-12-RGC	CL-12-RGD	CL-12-RGU-1	CL-12-RGFT	CL-12-RGF	3/4-10	1	3/4	7/8	1-1/8	7/8	5/16	3/4	1	
CL-1225-GSB					CL-12-RGU-2		CL-12-RGF-S										
					CL-12-RGU-3		CL-12-RGFN										
CL-1620-GSB	CL-16-RG	CL-16-RGT	—	CL-16-RGD	CL-16-RGU-1	CL-16-RGFT	CL-16-RGF	1"-8	2	1	1-1/8	1-1/2	1-1/8	3/8	1	1-1/4	
					CL-16-RGU-2		CL-16-RGF-S										
					CL-16-RGU-3		CL-16-RGFN										

BODY AND GRIPPER — ORDER SEPARATELY (METRIC)

CLM-10-GSP	CLM-10-RG	CLM-10-RGT	—	CLM-10-RGD	CLM-10-RGU-1	—	CLM-10-RGF	10mm	.67	.866	M6	.29	.512	.71	.95	—	
					CLM-10-RGU-2		CLM-10-RGF-S										
					CLM-10-RGU-3		CLM-10-RGFN										
CLM-12-GSP	CLM-12-RG	CLM-12-RGT	—	CLM-12-RGD	CLM-12-RGU-1	—	CLM-12-RGF	10mm	.75	.945	M8	.33	.591	.79	1.02	—	
					CLM-12-RGU-2		CLM-12-RGF-S										
					CLM-12-RGU-3		CLM-12-RGFN										
CLM-16-GSP	CLM-16-RG	CLM-16-RGT	—	CLM-16-RGD	CLM-16-RGU-1	—	CLM-16-RGF	12mm	.94	1.102	M10	.35	.787	.95	1.18	—	Fine .125x90°
					CLM-16-RGU-2		CLM-16-RGF-S										
					CLM-16-RGU-3		CLM-16-RGFN										
CLM-20-GSP	CLM-20-RG	CLM-20-RGT	—	CLM-20-RGD	CLM-20-RGU-1	—	CLM-20-RGF	16mm	1.18	1.181	M12	.33	.906	1.02	1.26	—	
					CLM-20-RGU-2		CLM-20-RGF-S										
					CLM-20-RGU-3		CLM-20-RGFN										
CLM-25-GSP	CLM-25-RG	CLM-25-RGT	—	CLM-25-RGD	CLM-25-RGU-1	—	CLM-25-RGF	20mm	1.42	1.42	M12	.47	1.102	1.26	1.50	—	
					CLM-25-RGU-2		CLM-25-RGF-S										
					CLM-25-RGU-3		CLM-25-RGFN										

GRIPPER SWIVEL CONTACT BOLTS

BODY: STEEL, CARBURIZED-HARDENED, BLACK OXIDE FINISH

O-RING: RUBBER

SERRATED SWIVEL BALL: HIGH-SPEED TOOL STEEL, BLACK OXIDE FINISH

FLAT SWIVEL BALL: STEEL, HARDENED, BLACK OXIDE FINISH

FLAT DELRIN® SWIVEL BALL: WHITE DELRI® 500

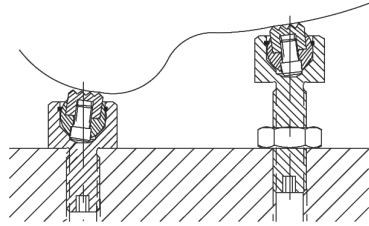

Gripper Swivel Contact Bolts are ideal as either fixed or adjustable supports under workpieces with curved or sloped surfaces.

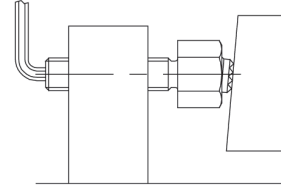

Gripper Swivel Contact Bolts can also be used as screw clamps by turning them with a hex wrench (large sizes only).



**Hardened
Tool Steel
(Serrated)**

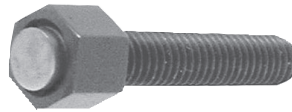

**Hardened
Steel
(Flat)**

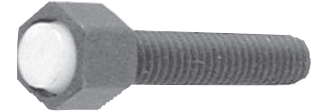

**Delrin®
(Flat)**

Mini Sizes

Mini threaded contact bolt with a built-in swivel ball held by a retaining ring. Choose from the three gripper types shown, serrated or flat. The gripper face is machined directly on the swivel ball. A positive stop prevents the ball from swiveling too far. Can be used as a contact bolt, or as a support. Available in thread sizes from #10-32 to 5/16-18 (M6 to M8 in metric), most in a choice of several lengths.

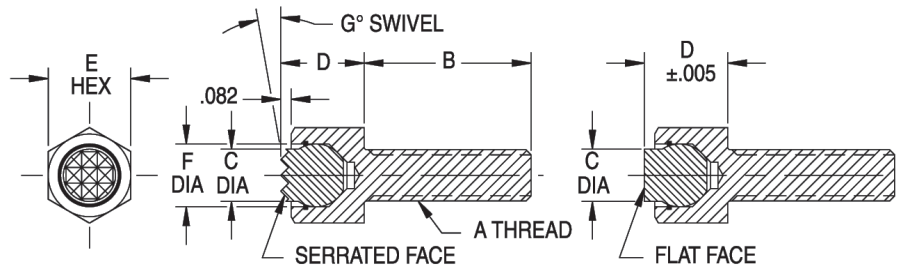

MINI — COMPLETE ASSEMBLY (INCH)

PART NO. — COMPLETE			A	B	C DIA	D	E	F DIA	G	SERRATIONS	
HARDENED TOOL STEEL (SERRATED)	HARDENED STEEL (FLAT)	DELIRIN® (FLAT)									
CL-305-GSB	CL-305-GBF	CL-305-GBFN	#10-32	1/2	5/32	5/16	3/8	3/16	14°	Super Fine	.062x90°
CL-405-GSB	CL-405-GBF	CL-405-GBFN	1/4-20	1/2	1/4	3/8	7/16	7/32			
CL-410-GSB	CL-410-GBF	CL-410-GBFN		1							
CL-415-GSB	CL-415-GBF	CL-415-GBFN		1-1/2							
CL-505-GSB	CL-505-GBF	CL-505-GBFN	5/16-18	1/2	5/16	7/16	1/2	3/8	14°	Extra Fine	.094x90°
CL-510-GSB	CL-510-GBF	CL-510-GBFN		1							
CL-515-GSB	CL-515-GBF	CL-515-GBFN		1-1/2							

MINI — COMPLETE ASSEMBLY (METRIC)

PART NO.	A THREAD	THREAD PITCH (mm)	B (mm)	C DIA (mm)	D (mm)	E (mm)	F DIA (mm)	G	SERRATIONS	SERRATION DIMENSIONS (mm)
CLM-612-GSB	M6	1	12	6	9.5	10	7	14°	SUPER FINE	1.6x90°
CLM-625-GSB	M6	1	25	6	9.5	10	7	14°	SUPER FINE	1.6x90°
CLM-640-GSB	M6	1	40	6	9.5	10	7	14°	SUPER FINE	1.6x90°
CLM-812-GSB	M8	1.25	12	8.5	13	13	10	12°	EXTRA FINE	2.4x90°
CLM-825-GSB	M8	1.25	25	8.5	13	13	10	12°	EXTRA FINE	2.4x90°
CLM-840-GSB	M8	1.25	40	8.5	13	13	10	12°	EXTRA FINE	2.4x90°

GRIPPER SWIVEL PADS

BODY AND GRIPPER SCREW: STEEL, CARBURIZED-HARDENED, BLACK OXIDE FINISH. O-RING: RUBBER
 SWIVEL BALL ON STANDARD SIZES: 440C STAINLESS STEEL, HEAT TREATED



Hardened Tool Steel (Serrated)



Carbide Tipped (Serrated)



Solid Carbide (Serrated)



Abrasive Diamond



Bonded Urethane



Carbide Tipped (Flat)



Hardened Steel or Stainless, or Delrin® (Flat)

Rest pad with a built-in swivel ball held by a retaining ring. A positive stop prevents the ball from swiveling too far. The swivel ball is removable to allow installing any of 11 different Round-Gripper types (order separately). Simply insert a hex wrench or rod to push the ball out from behind. Gripper Swivel Pads are available in a wide range of sizes. They can be surface-mounted or installed in a counterbored hole.

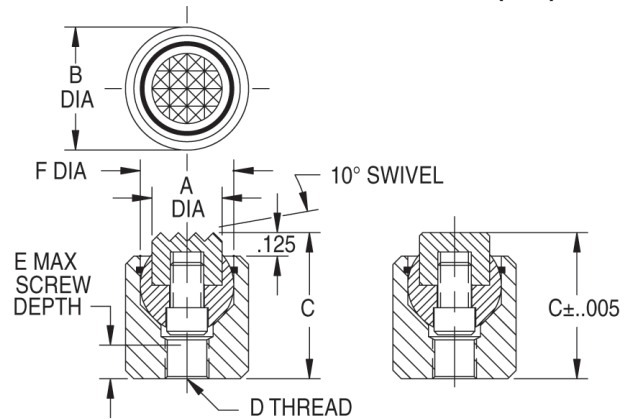

BODY AND GRIPPER — ORDER SEPARATELY (INCH)

PART NO. BODY WITHOUT GRIPPER	PART NO. — ROUND GRIPPER							A DIA	B DIA	C	D	E	F DIA	H	J	SERRATIONS	
	HARDENED TOOL STEEL (SERRATED)	CARBIDE TIPPED (SERRATED)	SOLID CARBIDE (SERRATED)	ABRASIVE DIAMOND	BONDED URETHANE	CARBIDE TIPPED (FLAT)	STEEL, SS, OR DELRIN® (FLAT)										
CL-6-GSP	CL-6-RG	CL-6-RGT	—	CL-6-RGD	CL-6-RGU-1 CL-6-RGU-2 CL-6-RGU-3	CL-6-RGFT	CL-6-RGF CL-6-RGF-S CL-6-RGFN	3/8	5/8	7/8	1/4-28	.24	1/2	3/4	1	XFine	.094x90°
CL-8-GSP	CL-8-RG	CL-8-RGT	CL-8-RGC	CL-8-RGD	CL-8-RGU-1 CL-8-RGU-2 CL-8-RGU-3	CL-8-RGFT	CL-8-RGF CL-8-RGF-S CL-8-RGFN	1/2	13/16	1	5/16-24	.35	5/8	7/8	1-1/8	Fine	.125x90°
CL-10-GSP	CL-10-RG	CL-10-RGT	CL-10-RGC	CL-10-RGD	CL-10-RGU-1 CL-10-RGU-2 CL-10-RGU-3	CL-10-RGFT	CL-10-RGF CL-10-RGF-S CL-10-RGFN	5/8	15/16	1	3/8-24	.28	3/4	7/8	1-1/8		
CL-12-GSP	CL-12-RG	CL-12-RGT	CL-12-RGC	CL-12-RGD	CL-12-RGU-1 CL-12-RGU-2 CL-12-RGU-3	CL-12-RGFT	CL-12-RGF CL-12-RGF-S CL-12-RGFN	3/4	1-1/8	1-1/16	1/2-20	.25	7/8	15/16	1-3/16		
CL-16-GSP	CL-16-RG	CL-16-RGT	—	CL-16-RGD	CL-16-RGU-1 CL-16-RGU-2 CL-16-RGU-3	CL-16-RGFT	CL-16-RGF CL-16-RGF-S CL-16-RGFN	1	1-1/2	1-3/8			.44	1-1/8	1-1/4	1-1/2	

BODY AND GRIPPER — ORDER SEPARATELY (METRIC)

CLM-10-GSP	CLM-10-RG	CLM-10-RGT	—	CLM-10-RGD	CLM-10-RGU-1 CLM-10-RGU-2 CLM-10-RGU-3	—	CLM-10-RGF CLM-10-RGF-S CLM-10-RGFN	10mm	.67	.866	M6	.29	.512	.71	.95	XFine	.094x90°
CLM-12-GSP	CLM-12-RG	CLM-12-RGT	—	CLM-12-RGD	CLM-12-RGU-1 CLM-12-RGU-2 CLM-12-RGU-3	—	CLM-12-RGF CLM-12-RGF-S CLM-12-RGFN	12mm	.75	.945	M8	.33	.591	.79	1.02	Fine	.125x90°
CLM-16-GSP	CLM-16-RG	CLM-16-RGT	—	CLM-16-RGD	CLM-16-RGU-1 CLM-16-RGU-2 CLM-16-RGU-3	—	CLM-16-RGF CLM-16-RGF-S CLM-16-RGFN	16mm	.94	1.102	M10	.35	.787	.95	1.18		
CLM-20-GSP	CLM-20-RG	CLM-20-RGT	—	CLM-20-RGD	CLM-20-RGU-1 CLM-20-RGU-2 CLM-20-RGU-3	—	CLM-20-RGF CLM-20-RGF-S CLM-20-RGFN	20mm	1.18	1.181	M12	.33	.906	1.02	1.26		
CLM-25-GSP	CLM-25-RG	CLM-25-RGT	—	CLM-25-RGD	CLM-25-RGU-1 CLM-25-RGU-2 CLM-25-RGU-3	—	CLM-25-RGF CLM-25-RGF-S CLM-25-RGFN	25mm	1.42	1.417	M12	.47	1.102	1.26	1.50		

GRIPPER SWIVEL PADS

BODY: STEEL, CARBURIZED-HARDENED, BLACK OXIDE FINISH

O-RING: RUBBER

SERRATED SWIVEL BALL: HIGH-SPEED TOOL STEEL, BLACK OXIDE FINISH

FLAT SWIVEL BALL: STEEL, HARDENED, BLACK OXIDE FINISH

FLAT DELRIN® SWIVEL BALL: WHITE DELRIN® 500

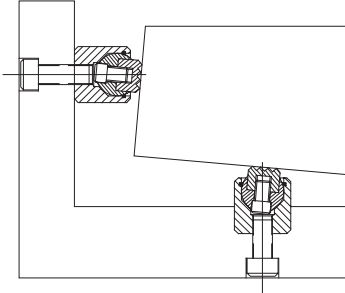

Gripper Swivel Pads can be surface mounted or installed in a counterbored hole.



Hardened Tool Steel (Serrated)



Hardened Steel (Flat)



Delrin® (Flat)

Mini sizes

Mini-size rest pad with a built-in swivel ball held by a retaining ring. Choose from the three gripper types shown, serrated or flat. The gripper face is machined directly on the swivel ball. A positive stop prevents the ball from swiveling too far. Gripper Swivel Pads can be surface mounted or installed in a counterbored hole. Available in the following body diameters from 3/8 to 5/8" (10 to 17mm in metric).

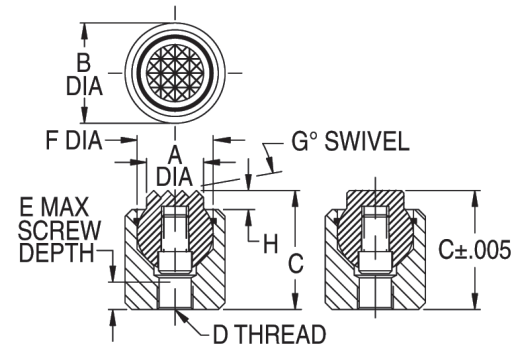

MINI — COMPLETE ASSEMBLY (INCH)

PART NO. — COMPLETE			A DIA	B DIA	C	D	E	F BALL DIA	G	H	SERRATIONS	
HARDENED TOOL STEEL (SERRATED)	HARDENED STEEL (FLAT)	DELRIN® (FLAT)									Super Fine	Extra Fine
CL-3-GSPS	CL-3-GSPF	CL-3-GSPN	5/32	3/8	3/8	#4-40	1/4	3/16	14°	.062	Super Fine	.062x90°
CL-4-GSPS	CL-4-GSPF	CL-4-GSPN	1/4	7/16	7/16	#8-32	5/32	9/32			Extra Fine	.094x90°
CL-5-GSPS	CL-5-GSPF	CL-5-GSPN	5/16	1/2	9/16	#10-32	5/32	3/8	17°	.125	Super Fine	.062x90°
CL-6-GSPS	CL-6-GSPF	CL-6-GSPN	3/8	5/8	15/16	1/4-28	1/4	1/2			Extra Fine	.094x90°

MINI — COMPLETE ASSEMBLY (METRIC)

PART NO.	A DIA (mm)	B DIA (mm)	C (mm)	D THREAD	THREAD PITCH (mm)	E (mm)	F BALL DIA (mm)	G	H (mm)	SERRATIONS	SERRATION DIMENSIONS (mm)	LOAD CAPACITY (kg)
CLM-6-GSPS	6	10	12	M4	.7	3.5	7	14°	1.5	SUPER FINE	1.6x90°	1100
CLM-8-GSPS	8.5	13	16	M5	.8	6.5	10	12°		EXTRA FINE	2.4x90°	2000
CLM-10-GSPS	10	17	19.5	M6	1	7	13	21°		EXTRA FINE	2.4x90°	2800

GRIPPER SWIVEL SCREWS

BODY: STEEL, CARBURIZED-HARDENED, BLACK OXIDE FINISH
 SWIVEL BALL: HIGH-SPEED TOOL STEEL



Hardened Tool Steel (Serrated)



Hardened Tool Steel (Flat)

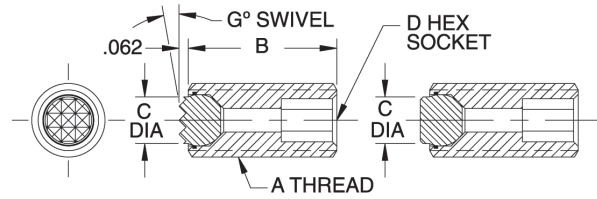

Screw clamp with a hardened tool steel swivel ball, either serrated or flat. A positive stop prevents the ball from swiveling too far. Serrated grippers are designed to slightly penetrate the workpiece to significantly increase gripping force, rather than relying on static friction alone. Available in thread sizes from 3/8-16 to 5/8-11 (M10 to M16 in metric) each in a choice of several lengths.

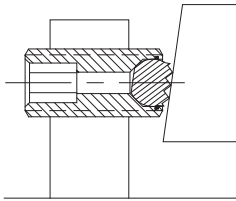

COMPLETE ASSEMBLY (INCH)

PART NO. — COMPLETE		A	B	C DIA	D	G	SERRATIONS		
HARDENED TOOL STEEL (SERRATED)	HARDENED TOOL STEEL (FLAT)								
CL-605-GSS	CL-605-GSF	3/8-16	1/2	5/32	3/16	14°	Super Fine	.062x90°	
CL-610-GSS	CL-610-GSF		1						
CL-620-GSS	CL-620-GSF		2						
CL-810-GSS	CL-810-GSF	1/2-13	1	1/4	1/4		Extra Fine	.094x90°	
CL-820-GSS	CL-820-GSF		2						
CL-830-GSS	CL-830-GSF		3						
CL-1010-GSS	CL-1010-GSF	5/8-11	1	5/16	5/16				
CL-1020-GSS	CL-1020-GSF		2						
CL-1030-GSS	CL-1030-GSF		3						

COMPLETE ASSEMBLY (METRIC)

CLM-1025-GSS	CLM-1025-GSF	M10	.98	.16	5mm	15°	Super Fine	.062x90°
CLM-1050-GSS	CLM-1050-GSF		1.97					
CLM-1225-GSS	CLM-1225-GSF	M12	.98	.24	6mm	14°	Super Fine	.062x90°
CLM-1250-GSS	CLM-1250-GSF		1.97					
CLM-1625-GSS	CLM-1625-GSF	M16	.98	.33	8mm	12°	Extra Fine	.094x90°
CLM-1650-GSS	CLM-1650-GSF		1.97					

ROUND CARBIDE PADS

SOLID CARBIDE

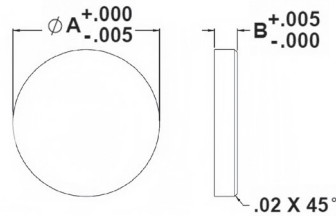

These handy round pads are made from solid carbide for high wear resistance. Pads can be brazed or bonded to install. The bottom is slightly chamfered for clearance in a mounting bracket. Available in diameters from 1/4 to 1". Made in USA.

PART NO.	A	B
CL-4-RCP	1/4	1/8
CL-5-RCP	5/16	1/8
CL-6-RCP	3/8	1/8
CL-8-RCP	1/2	1/8
CL-10-RCP	5/8	1/8
CL-12-RCP	3/4	1/8
CL-16-RCP	1	5/32

REST BUTTONS

TYPES



REST BUTTONS

Precision height locator with a close-tolerance shank for installation in a reamed hole. Rest Buttons are extremely useful as supports, side locator pads, and jig feet. Available in steel, stainless steel, or steel with a carbide pad.



CARBIDE-TIPPED REST BUTTONS

Precision height locator similar to the rest buttons above, but with a carbide tip for extra wear resistance.



AIR REST BUTTONS

Air Rest Buttons are used to incorporate pneumatic position control to detect proper workpiece loading in a machining fixture. These modular units consist of a threaded body installed in the fixture, which holds a precision floating plunger.



SPHERICAL RADIUS LOCATOR BUTTONS

Precision height locator with a spherical-radius head to minimize workpiece contact area. Close-tolerance shank allows press-fit installation in a reamed hole.



JIG REST BUTTONS

Precision height locator with a counterbored hole for mounting with a Socket-Head Cap Screw (not furnished). Jig Rest Buttons are extremely useful as supports, side locator pads, and jig feet.



SCREW REST PADS

Precision height locator with a threaded shank for installation in a tapped hole. Cone shape provides a small contact area in combination with a large stable base. Screw Rest Pads are extremely useful as supports, side locator pads, and jig feet.



SCREW REST BUTTONS

Threaded rest button with a hex head machined .005 to .010" over nominal height for finish grinding after installation.



SWIVEL CONTACT BOLTS

Swivel contact bolts are precision swivel balls that can be used either as a contact bolt or a rest pad. Ideal for evenly distributing clamping pressure on sloped surfaces.



DRILL JIG FEET

Precision jig foot available in four heights. Dowel in place to prevent rotation.



DOUBLE-END JIG FEET

Tapped jig foot commonly used in pairs with a stud.

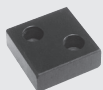

JIG LEG PLATES

Precision ground pad with a large contact area. Can be used either as a jig foot, or as a rest pad for heavy workpieces. Choice of three sizes.

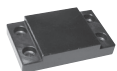

HEAVY-DUTY REST PADS

Large, precision rest pad for heavy-duty applications. These hardened pads have a large, durable contact surface to support heavy workpieces, or to serve as wear plates. Choice of four sizes.



HEIGHT SHIMS

Precision shims that allow raising a height locator by a small, exact amount. Ideal when supporting at different levels underneath a workpiece.

DELTRIN® REST BUTTONS

MATERIAL: WHITE DELTRIN®

Delrin® Rest Buttons are similar to our standard Rest Buttons, and Delrin® prevents marring. Rest Buttons are extremely useful as supports, side locator pads, and jig feet. Made in USA.

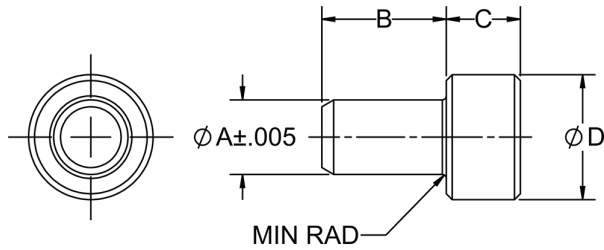

PART NO.	A DIA	B	C	D DIA
CL-1-RB-N	.2510	.50	.500	.50
CL-2-RB-N	.2510	.50	.250	.50
CL-3-RB-N	.2510	.50	.375	.50
CL-4-RB-N	.3760	.63	.500	.63
CL-5-RB-N	.3760	.63	.250	.63
CL-6-RB-N	.3760	.63	.375	.63
CL-7-RB-N	.3760	.63	.625	.63
CL-8-RB-N	.3760	.63	.750	.63
CL-9-RB-N	.5010	.63	.500	.88
CL-10-RB-N	.6260	.75	.500	1.00
CL-11-RB-N	.7515	.88	.625	1.25
CL-12-RB-N	.1885	.38	.250	.38
CL-13-RB-N	.1885	.38	.375	.38
CL-14-RB-N	.1885	.38	.500	.38
CL-15-RB-N	.5010	.63	.375	.88
CL-16-RB-N	.5010	.63	.625	.88
CL-17-RB-N	.6260	.75	.375	1.00
CL-18-RB-N	.6260	.75	.750	1.00
CL-19-RB-N	.7515	.88	.500	1.25

5

SPHERICAL DELTRIN® REST BUTTONS

MATERIAL: WHITE DELTRIN®

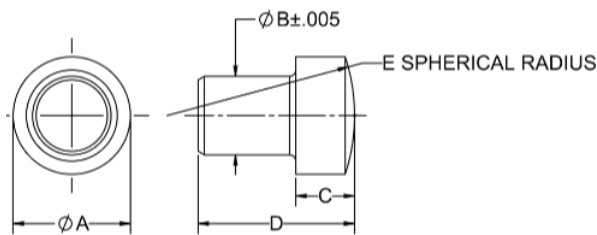

PART NO.	A DIA	B DIA	C	D	E
CL-1-SLB-N	5/16	.1885	.125	.375	1/2
CL-2-SLB-N	3/8	.2510	.188	.500	5/8
CL-3-SLB-N	1/2	.3760	.188	.563	3/4
CL-4-SLB-N	1/2	.3760	.250	.625	3/4
CL-5-SLB-N	1/2	.3760	.375	.750	3/4
CL-6-SLB-N	1/2	.3760	.500	.875	3/4

REST BUTTONS

STEEL: 1144, HEAT TREATED RC 40-45, BLACK OXIDE FINISH
 STAINLESS STEEL: 300-SERIES

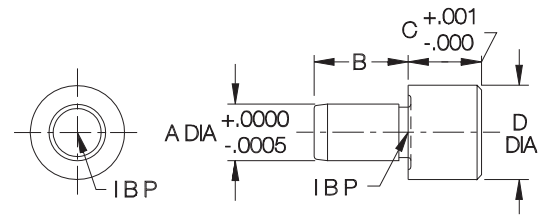

Precision height locator with a close-tolerance shank for installation in a reamed hole. Rest Buttons are extremely useful as supports, side locator pads, and jig feet. Available in steel, stainless steel, or steel with a carbide pad on page 220.

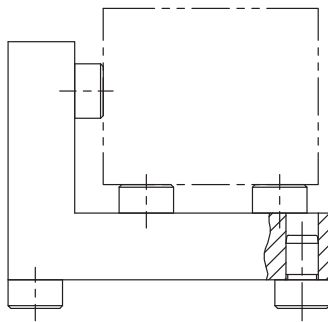

STEEL (INCH)

PART NO.	A DIA	B	C	D DIA
CL-1-RB-N	.2510	.50	.500	.50
CL-2-RB-N			.250	
CL-3-RB-N			.375	
CL-4-RB-N			.500	
CL-5-RB-N	.3760	.63	.250	.63
CL-6-RB-N			.375	
CL-7-RB-N			.625	
CL-8-RB-N			.750	
CL-9-RB-N	.5010	.75	.500	.88
CL-10-RB-N	.6260		1.00	
CL-11-RB-N	.7515	.88	.625	1.25
CL-12-RB-N	.1885	.38	.250	.38
CL-13-RB-N			.375	
CL-14-RB-N			.500	
CL-15-RB-N	.5010	.63	.375	.88
CL-16-RB-N			.625	
CL-17-RB-N			.375	
CL-18-RB-N	.6260	.75	.750	1.00
CL-19-RB-N	.7515	.88	.500	1.25

STAINLESS STEEL (INCH)

PART NO.	A DIA		B	C		D DIA
	NOMINAL	ACTUAL		NOMINAL	ACTUAL	
CL-26432	3/16	.1885	1/4	1/4	.2500	3/8
CL-26433				3/8	.3750	
CL-26434				1/2	.5000	
CL-26542	1/4	.2510	5/16	1/4	.2500	1/2
CL-26646	5/16	.3135	5/16	3/4	.7500	1/2

STEEL (METRIC)

PART NO.	A DIA NOMINAL (mm)	A DIA ACTUAL (mm)	B (mm)	C (mm)	D DIA (mm)
CLM-605-RB	6	6.025	8	5	10
CLM-610-RB				10	
CLM-805-RB	8	8.025	10	5	16
CLM-810-RB				10	
CLM-815-RB				15	
CLM-820-RB				20	
CLM-1010-RB	10	10.025	12	10	20
CLM-1015-RB				15	
CLM-1020-RB				20	

5

CARBIDE-TIPPED REST BUTTONS

BODY: 1144 STEEL, HEAT TREATED RC 40-45, BLACK OXIDE FINISH
PAD: CARBIDE

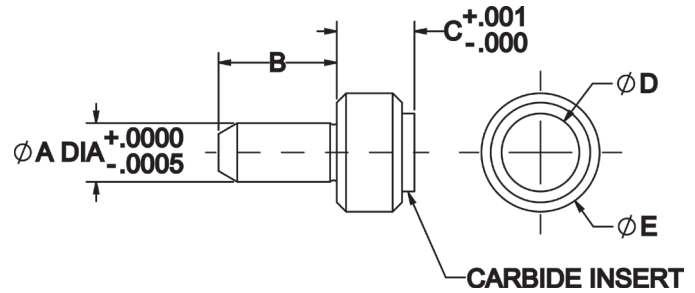

Carbide-Tipped Rest Buttons are available in many of the same diameters and heights as our standard Rest Buttons on the opposite page, so they can be used as direct replacements where additional wear resistance is desired. These rest buttons feature a thick embedded carbide pad, finish machined to a precision height. Like a standard Rest Button, these locators have a close-tolerance shank for installation in a reamed hole.

STEEL (INCH)

PART NO.	A DIA		B	C		D DIA	E DIA
	NOMINAL	ACTUAL		NOMINAL	ACTUAL		
CL-12-CTRB	3/16	.1885	3/8	1/4	.2500	1/4	3/8
CL-14-CTRB				1/2	.5000		
CL-3-CTRB	1/4	.2510	1/2	3/8	.3750	3/8	1/2
CL-5-CTRB				1/4	.2500		
CL-6-CTRB	3/8	.3760	5/8	3/8	.3750	1/2	5/8
CL-7-CTRB				5/8	.6250		
CL-15-CTRB				3/8	.3750	3/4	7/8
CL-9-CTRB	1/2	.5010	5/8	1/2	.5000		
CL-19-CTRB	3/4	.7515	7/8	1/2	.5000	1	1-1/4

SPHERICAL RADIUS LOCATOR BUTTONS

1144 STEEL, HEAT TREATED RC 40-45, BLACK OXIDE FINISH

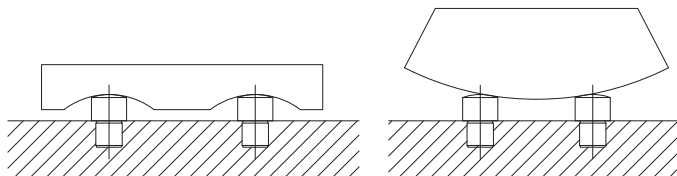

Precision height locator with a spherical-radius head to minimize workpiece contact area. Close-tolerance shank allows press-fit installation in a reamed hole. Spherical-Radius Locator Buttons are extremely useful as supports, side locator pads, and jig feet.

PART NO.	B DIA	A DIA	C	D	E
CL-1-SLB	3/16	5/16	.1250	3/8	1/2
CL-2-SLB	1/4	3/8	.1875	1/2	5/8
CL-3-SLB			.1875	9/16	
CL-4-SLB	3/8	1/2	.2500	5/8	3/4
CL-5-SLB			.3750	3/4	
CL-6-SLB			.5000	7/8	

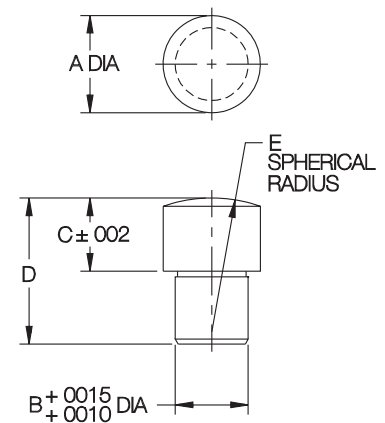

AIR REST BUTTONS

PLUNGER & BODY: 1144 STEEL, HEAT TREATED RC 40-45, BLACK OXIDE FINISH



Air Rest Buttons allow using pneumatic position control to detect proper workpiece loading in a machining fixture. These modular units consist of a threaded body installed in a fixture, which holds a precision floating plunger. This plunger has a reamed hole, available in a choice of three diameters, that accepts any height of our standard press-fit-type Rest Buttons.

Proper placement of a workpiece on the Air Rest Button assembly causes the plunger to fully retract into the body. This seals off air flow, which increases the overall pressure of the system (30 psi maximum air pressure). This pressure value can be read using an analog or digital pressure sensor which can then be tied into a PLC or control system. **Patent pending.**

After installation, the retracted plunger's top surface will be .145" above the fixture surface before a Rest Button is installed (the body's top flange is .125" thick, and the plunger protrudes .020" above the flange). If desired to achieve ultimate precision, the top surfaces of all Rest Buttons can be reground after installation of all Rest Button assemblies.

When using pneumatic position control, please consider that keeping the support surfaces reasonably clean is always important. Operations that produce fine chips or grit, such as when machining cast iron, should be avoided. The use of flood coolant, or aggressive coolant, should also be avoided.

For more information and videos, see our online catalog at carrlane.com.

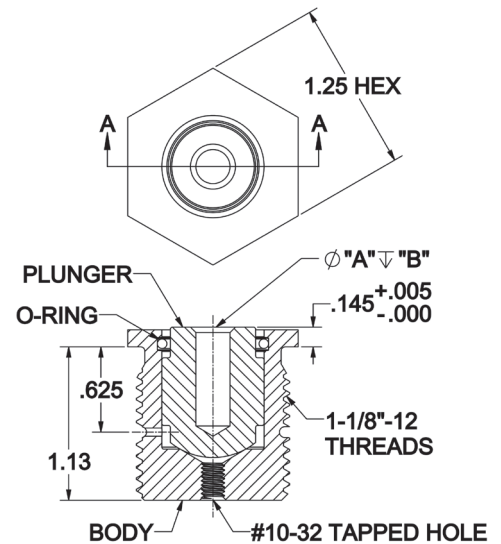

5

PART NO.	A DIA		B DIA	MAXIMUM AIR PRESSURE (psi)
	NOMINAL	ACTUAL		
CL-213-ARB	3/16	.1870/.1875	11/16	30
CL-214-ARB	1/4	.2495/.2500		
CL-216-ARB	3/8	.3745/.3750		

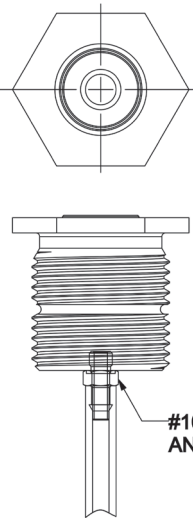
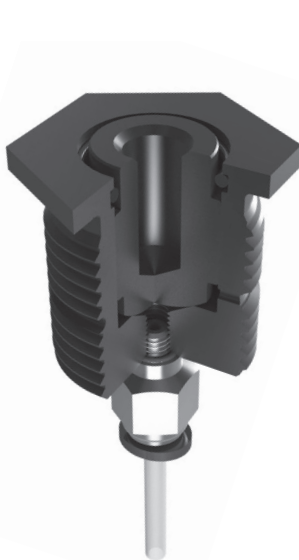

Air connection with external fitting

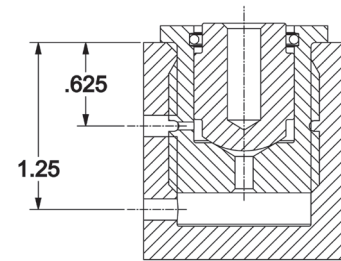
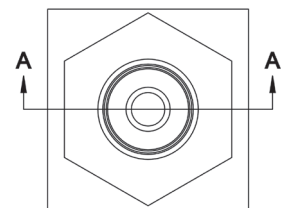

Air connection with drilled manifold passage

AIR REST BUTTONS

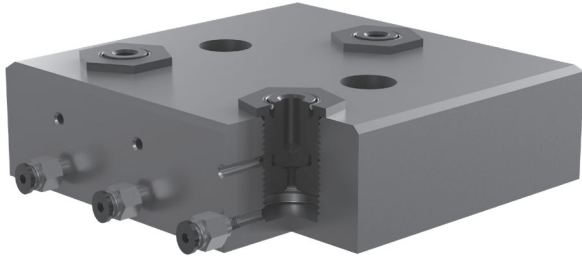

This example uses three Air Rest Buttons to provide full 3-point support under a workpiece.

5

For more information and videos, see our online catalog at carrlane.com.

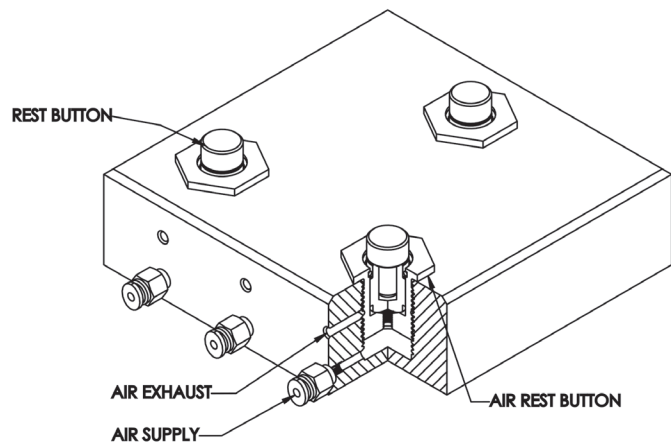

SYSTEM EXAMPLE 1

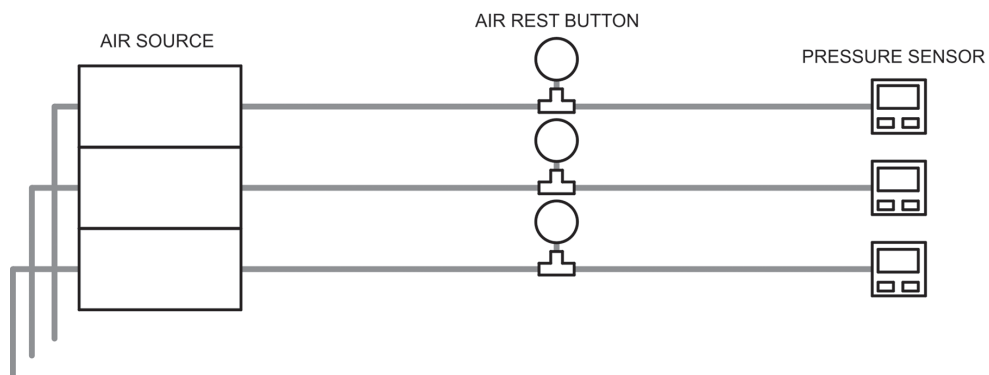

SYSTEM EXAMPLE 2

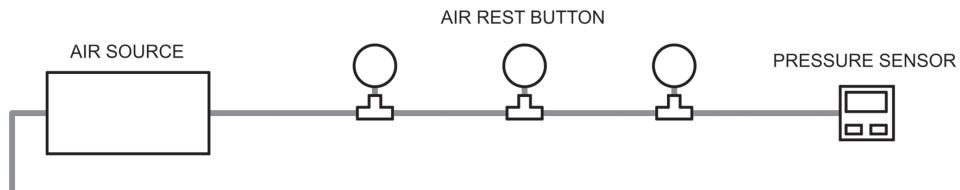

JIG REST BUTTONS

1215 STEEL, CARBURIZED-HARDENED, BLACK OXIDE FINISH



Precision height locator with a counterbored hole for mounting with a Socket-Head Cap Screw (not furnished). Jig Rest Buttons are extremely useful as supports, side locator pads, and jig feet.

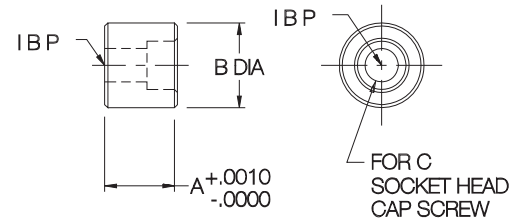
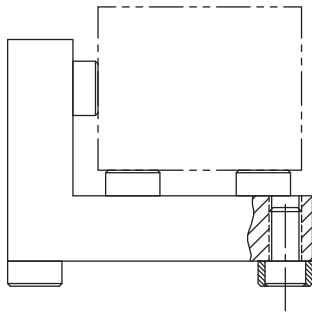

INCH

PART NO.	B DIA	A		C
		NOMINAL	ACTUAL	
CL-24-JRB	1/2	1/8	.1250	#8 Flat Head*
CL-00-JRB		3/8	.3750	#10
CL-0-JRB		1/2	.5000	
CL-12-JRB	5/8	1/4	.2500	#10 Flat Head*
CL-13-JRB		3/8	.3750	1/4
CL-1-JRB		1/2	.5000	
CL-14-JRB		5/8	.6250	
CL-2-JRB		3/4	.7500	
CL-16-JRB	1	1.0000	1/4	
CL-17-JRB	3/8	.3750		
CL-18-JRB	1/2	.5000		5/16
CL-3-JRB	5/8	.6250		
CL-19-JRB	3/4	.7500		
CL-20-JRB	1	1.0000	3/8	
CL-25-JRB	1/2	.5000		
CL-21-JRB	3/4	.7500		
CL-6-JRB	1-1/4	1		1.0000
CL-7-JRB		1-1/2	1.5000	
CL-8-JRB		2	2.0000	

* Countersunk for flat-head screw these sizes only.

METRIC

PART NO.	B DIA	A		C
		NOMINAL	ACTUAL	
CLM-1-JRB	.63	10mm	.3937	M5
CLM-2A-JRB		15mm	.5906	
CLM-4-JRB	.79	10mm	.3937	M6
CLM-6A-JRB		15mm	.5906	
CLM-7A-JRB		20mm	.7874	
CLM-8-JRB		25mm	.9843	
CLM-11A-JRB	.98	15mm	.5906	M8
CLM-12A-JRB		20mm	.7874	
CLM-13-JRB		25mm	.9843	
CLM-14A-JRB	1.26	20mm	.7874	M10
CLM-15-JRB		25mm	.9843	
CLM-16A-JRB		30mm	1.1811	
CLM-17A-JRB		50mm	1.9685	

5

SCREW REST PADS

1215 STEEL, CARBURIZED-HARDENED, BLACK OXIDE FINISH

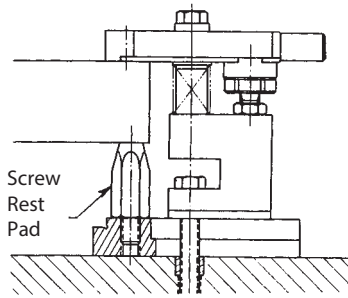

Precision height locator with a threaded shank for installation in a tapped hole. Cone shape provides a small contact area in combination with a large stable base. Screw Rest Pads are extremely useful as supports, side locator pads, and jig feet.

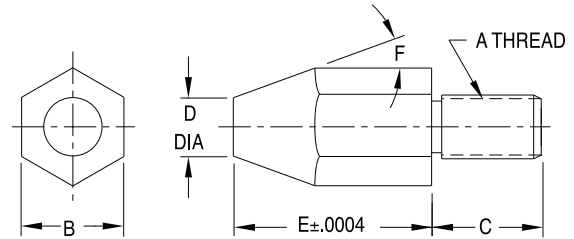

INCH

PART NO.	A	B	C	D DIA	E	F
CL-MF25-4801	5/16-18	3/4	5/8	5/16	.2500	75°
CL-MF25-4802					.3750	60°
CL-MF25-4803					.5000	35°
CL-MF25-4804					.7500	25°
CL-MF25-4805					1.0000	20°
CL-MF25-4806					1.2500	15°
CL-MF25-4807					1.5000	15°
CL-MF40-4801	1/2-13	7/8	15/16	1/2	.2500	75°
CL-MF40-4802					.3750	60°
CL-MF40-4803					.5000	35°
CL-MF40-4804					.7500	25°
CL-MF40-4805					1.0000	20°
CL-MF40-4806					1.2500	15°
CL-MF40-4807					1.5000	15°
CL-MF40-4808	2.0000	15°				
CL-MF50-4801	5/8-11	1	1-1/4	5/8	.2500	75°
CL-MF50-4802					.3750	60°
CL-MF50-4803					.5000	35°
CL-MF50-4804					.7500	25°
CL-MF50-4805					1.0000	20°
CL-MF50-4806					1.2500	15°
CL-MF50-4807					1.5000	15°
CL-MF50-4808	2.0000	15°				

METRIC

PART NO.	A	B	C	D DIA	E	F
CL-MF08-4801	M8	17mm	.63	.31	.1969 (5mm)	75°
CL-MF08-4802					.3937 (10mm)	60°
CL-MF08-4803					.5906 (15mm)	35°
CL-MF08-4804					.7874 (20mm)	25°
CL-MF08-4805					.9843 (25mm)	20°
CL-MF08-4806					1.1811 (30mm)	15°
CL-MF08-4808					1.5748 (40mm)	15°
CL-MF12-4801	M12	19mm	.94	.47	.1969 (5mm)	75°
CL-MF12-4802					.3937 (10mm)	60°
CL-MF12-4803					.5906 (15mm)	35°
CL-MF12-4804					.7874 (20mm)	25°
CL-MF12-4805					.9843 (25mm)	20°
CL-MF12-4806					1.1811 (30mm)	15°
CL-MF12-4808					1.5748 (40mm)	15°
CL-MF12-4810	1.9685 (50mm)	15°				
CL-MF16-4802	M16	24mm	1.26	.63	.3937 (10mm)	60°
CL-MF16-4803					.5906 (15mm)	35°
CL-MF16-4804					.7874 (20mm)	25°
CL-MF16-4805					.9843 (25mm)	20°
CL-MF16-4806					1.1811 (30mm)	15°
CL-MF16-4808					1.5748 (40mm)	15°
CL-MF16-4810					1.9685 (50mm)	15°

SCREW REST BUTTONS

1215 STEEL, CARBURIZED-HARDENED, BLACK OXIDE FINISH



Threaded rest button with a hex head machined .005 to .010" over nominal height for finish grinding after installation.

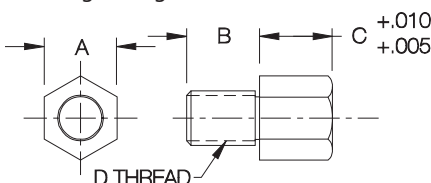

INCH

PART NO.	A	B	C		D
			NOMINAL	ACTUAL	
CL-1-SRB	3/8	3/8	1/4	.2500	1/4-20
CL-2-SRB			3/8	.3750	
CL-3-SRB			1/2	.5000	
CL-4-SRB			3/4	.7500	
CL-5-SRB	1/2	1/2	1	1.0000	3/8-16
CL-6-SRB			1/4	.2500	
CL-7-SRB			3/8	.3750	
CL-8-SRB			1/2	.5000	
CL-9-SRB	5/8	5/8	3/4	.7500	1/2-13
CL-10-SRB			1	1.0000	
CL-11-SRB			1/4	.2500	
CL-12-SRB			3/8	.3750	
CL-13-SRB	5/8	5/8	1/2	.5000	1/2-13
CL-14-SRB			5/8	.6250	
CL-15-SRB			3/4	.7500	
CL-16-SRB			1	1.0000	

METRIC

PART NO.	A	B	C		D
			NOMINAL	ACTUAL	
CLM-605-SRB	10mm	.39	5mm	.1969	M6
CLM-610-SRB			10mm	.3937	
CLM-615-SRB			15mm	.5906	
CLM-620-SRB			20mm	.7874	
CLM-625-SRB			25mm	.9843	
CLM-1005-SRB	13mm	.51	5mm	.1969	M10
CLM-1010-SRB			10mm	.3937	
CLM-1015-SRB			15mm	.5906	
CLM-1020-SRB			20mm	.7874	
CLM-1025-SRB			25mm	.9843	
CLM-1205-SRB	17mm	.63	5mm	.1969	M12
CLM-1210-SRB			10mm	.3937	
CLM-1215-SRB			15mm	.5906	
CLM-1220-SRB			20mm	.7874	
CLM-1225-SRB			25mm	.9843	

SWIVEL CONTACT BOLTS

BALL: CHROME STEEL, HEAT TREATED RC 60-67
 BODY: 1144 STEEL, HEAT TREATED RC 35-40, BLACK OXIDE FINISH



Precision swivel ball that can be used as either a contact bolt or rest pad.

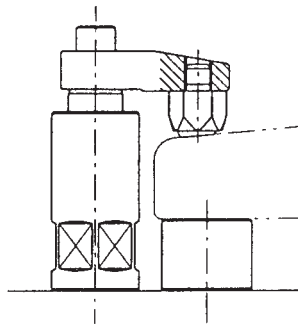

Swivel Contact Bolts are ideal for evenly distributing clamping pressure on sloped surfaces.

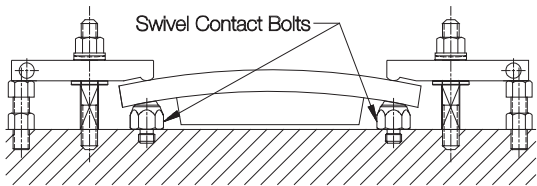
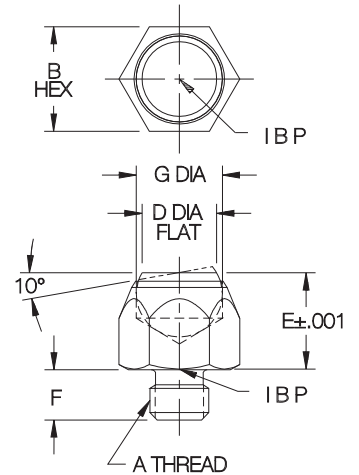

Swivel Contact Bolts are precision ground for accurate height location, even on sloped surfaces. **INFO+**: See Riser Blocks (page 432), Extension Supports (page 433), and Height Shims (page 228).

INCH

PART NO.	A	B	D DIA	E		F	G
				NOMINAL	ACTUAL		
CL-MF25-2502	5/16-18	9/16	13/32	1/2	.5000	.32	15/32
CL-MF30-2503	3/8-16	13/16	19/32	13/16	.8125	.47	23/32
CL-MF40-2501	1/2-13	7/8	5/8	13/16	.8125	.41	23/32
CL-MF50-2501	5/8-11	1-1/16	13/16	1	1.0000	.61	29/32

THROUGH HOLE SCREW REST BUTTON

1215 STEEL, CARBURIZED-HARDENED, BLACK OXIDE FINISH

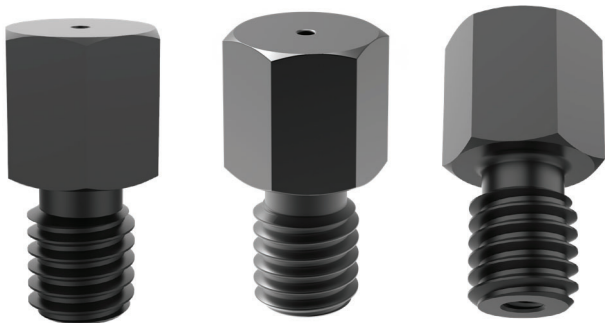

New item!

Position sensing threaded rest button with a hex machined .005 to .01" over nominal height for finish grinding after installation. Sensor contains .06 through hole allowing air to travel through and detect whether a part is loaded utilizing a sensor. The position sensing rest button also contains a #10-32 tapped hole on the shank for installation of a threaded fitting for easy air line installation. Available in inch and metric. Made in the USA.

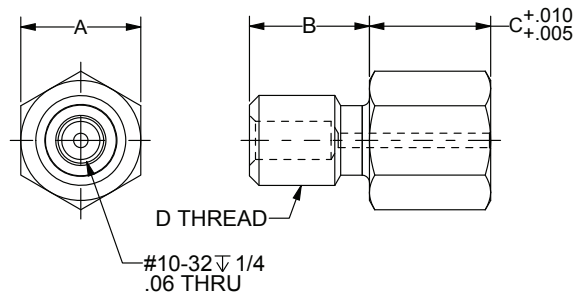

INCH

PART NO.	A	B	C NOMINAL	C ACTUAL	D THREAD
CL-8-SRB-PR	1/2	1/2	1/2	.5000	3/8-16

METRIC

CLM-1205-SRB-PR	17	16	5	5.13mm / 5.26mm	M12
-----------------	----	----	---	-----------------	-----

JIG LEG PLATES

1020 STEEL, CARBURIZED-HARDENED, BLACK OXIDE FINISH

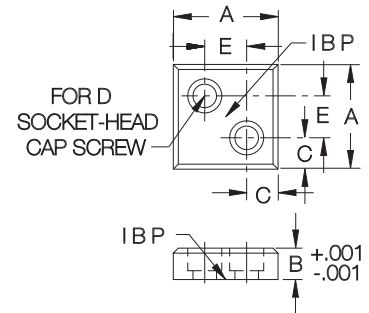
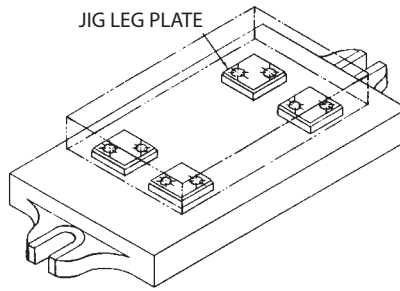
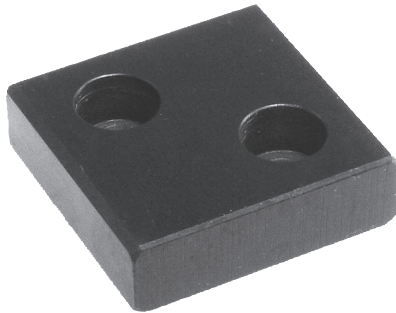

Precision ground pad with a large contact area. Can be used either as a jig foot, or as a rest pad for heavy workpieces. Choice of three sizes.

INCH

PART NO.	A	B	C	D	E
CL-1-JLP	1	.3125	5/16	#10-32 OR M5	3/8
CL-2-JLP	1-1/4	.3750	3/8	1/4-20 OR M6	1/2
CL-3-JLP	1-1/2	.4375	7/16		5/8

5

HEAVY-DUTY REST PADS

1018 STEEL, CARBURIZED-HARDENED, BLACK OXIDE FINISH

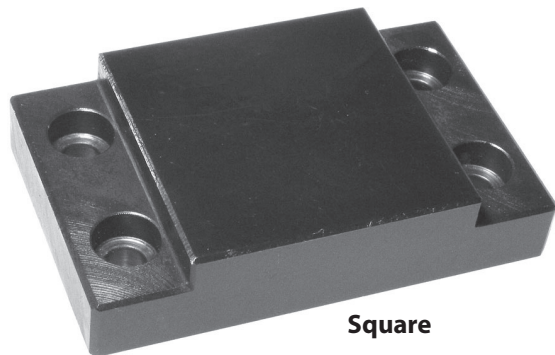

Square

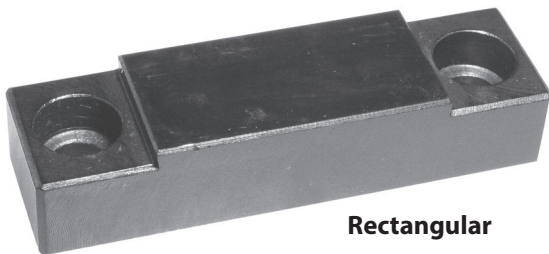

Rectangular

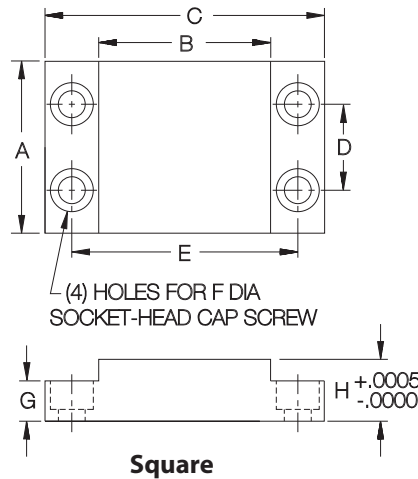

Square

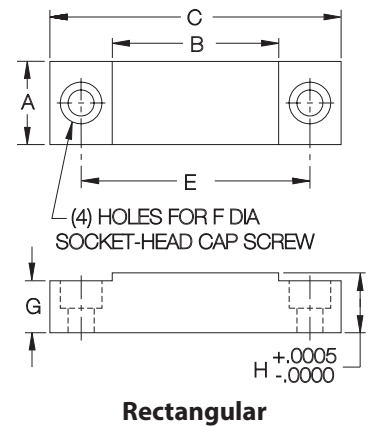

Rectangular

Large, precision rest pad for heavy-duty applications. These hardened pads have a large, durable contact surface to support heavy workpieces, or to serve as wear plates. Choice of four sizes.

SQUARE (INCH)

PART NO.	A	B	C	D	E	F	G	H
CL-1-HDRP	2	2	3-1/4	1	2-1/2	1/4-20 OR M6	1/2	.7500

RECTANGULAR (INCH)

CL-2-HDRP	1	2	3-1/2	—	2-3/4	5/16-18 OR M8	5/8	.7500
CL-3-HDRP		3	4-1/2		3-3/4			
CL-4-HDRP		4	5-1/2		4-3/4			

HEIGHT SHIMS

1010 STEEL

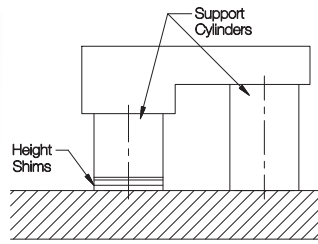
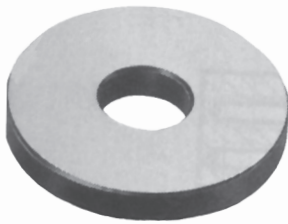

Precision shims that allow raising a height locator by a small, exact amount. Ideal when supporting at different levels underneath a workpiece, as in the example shown using Support Cylinders. Thickness tolerance is $\pm .0003$ on .125 size, $\pm 10\%$ on smaller sizes.

PART NO.	COLUMN HEAD??	A	B DIA	C DIA
CL-MF25-7125	MINI	.125		
CL-MF40-7002	STANDARD	.002	9/16	1-5/8
CL-MF40-7003		.003		
CL-MF40-7004		.004		
CL-MF40-7005		.005		
CL-MF40-7010		.010		
CL-MF40-7020		.020		
CL-MF40-7062		.062		
CL-MF40-7125		.125		
CL-MF50-7002	HEAVY	.002	11/16	1-7/8
CL-MF50-7003		.003		
CL-MF50-7004		.004		
CL-MF50-7005		.005		
CL-MF50-7010		.010		
CL-MF50-7020		.020		
CL-MF50-7062		.062		
CL-MF50-7125		.125		

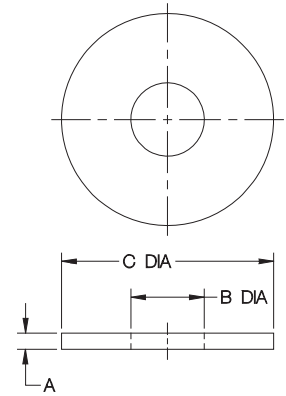

ECCENTRIC LEVELING LUGS

1215 STEEL, CARBURIZED-HARDENED, BLACK OXIDE FINISH



Precision side locator that can be doweled in place after adjustment. Use for vertical leveling or horizontal locating. Available hardened, or soft to allow drilling and reaming after installation.

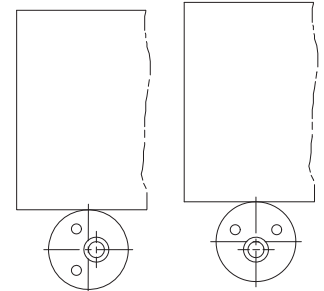
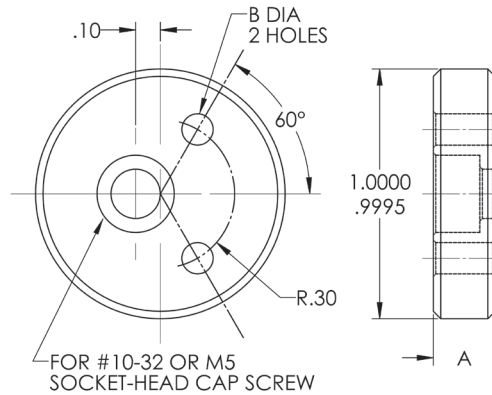

HARDENED		
PART NO.	A	B DIA
CL-3-ELL	1/4	1/8 REAMED
CL-4-ELL	3/8	1/8 REAMED
SOFT		
CL-2-ELL	3/8	#31

ECCENTRIC-LEVELING-LUG COVERS

MILD STEEL, BLACK OXIDE FINISH

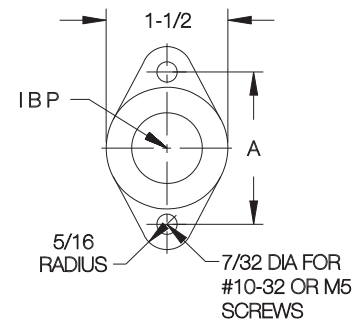
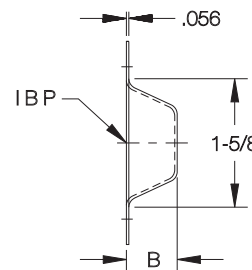
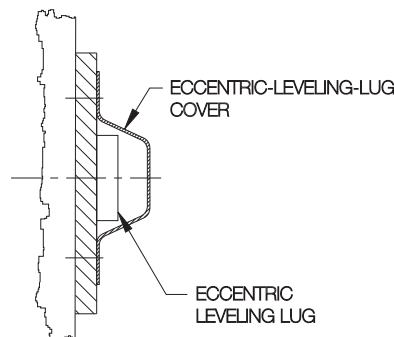

Sturdy cover that protects an Eccentric Leveling Lug from damage or misadjustment after setting.

PART NO.	A	B
CL-1-COVER	1-7/8	5/8

MANUAL WORK SUPPORTS

BODY & PLUNGER: CARBON STEEL, CASE HARDENED, BLACK OXIDE FINISH
HANDLE: ZINC DIE CASTING, ENAMEL PAINT

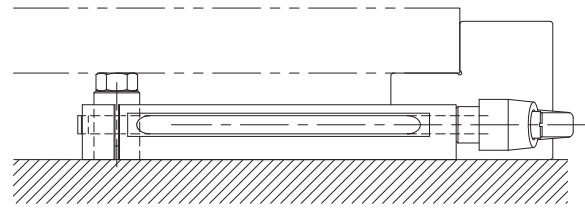

Low profile allows reaching far underneath low workpieces.

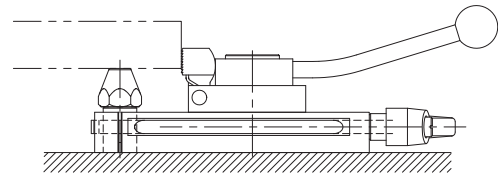

Mounting slot allows stacking other components, such as this Cam Edge Clamp, on top of the support.

Spring-extended work support with an extremely low profile. Ideal for supporting in hard-to-reach places, because the handle can be positioned for convenient access. Turning the handle counterclockwise unlocks the plunger, allowing the plunger to float. Turning the handle clockwise locks the plunger. If desired, the plunger can be locked in retracted position before loading, for easier loading of light parts. The zinc die-cast Adjustable Handle can be reset to any angle for best leverage.

5



Screw Rest Pads available from 1/4" to 2" tall, are ideal fixed contact bolts to use in the support plunger.



INFO+: For adjustable contact screws, see Knurled Screw Jacks.

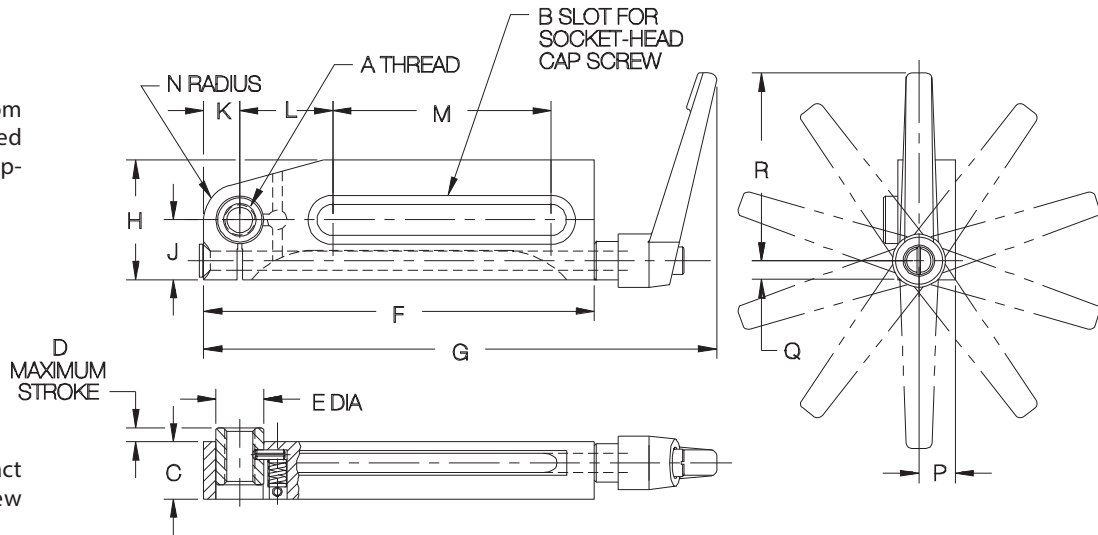

INCH

PART NO.	A	B	C	D	E DIA	F	G	H	J	K	L	M	N	P	Q	R	LOAD CAPACITY (LBS)
CL-MF25-5701	5/16-18	5/16-18 or M8	.708	.118	.591	3-3/8	5-1/16	1-3/16	25/32	13/32	1-1/16	1-13/32	13/32	.433	9/32	2-9/16	110
CL-MF40-5701	1/2-13	1/2-13 or M12	.945	.236	.787	6-1/2	8-9/16	2	1	19/32	1-17/32	3-9/16	19/32	.551	5/16	3-1/8	550
CL-MF50-5702	5/8-11	5/8-11 or M16	1.339	.433	1.102	7-1/2	10-7/16	2-3/8	1-7/16	13/16	1-3/4	4-1/16	13/16	.846	1/2	4-5/16	1100

METRIC

PART NO.	A THREAD	THREAD PITCH (mm)	B MOUNTING SCREW	C (mm)	D (mm)	E DIA (mm)	F (mm)	G (mm)	H (mm)	J (mm)	K (mm)	L (mm)	M (mm)	N (mm)	P (mm)	Q (mm)	R (mm)	LOAD CAPACITY (kg)
CL-MF08-5701	M8	1.25	5/16" or M8	18	3	15	85.5	129	30	20	10.5	27	35.5	10.5	11	7	65	50
CL-MF12-5701	M12	1.75	1/2" or M12	24	6	20	165	217	51	25.5	15	39	90.5	15	14	8	79.5	250
CL-MF16-5702	M16	2	5/8" or M16	34	11	28	190.5	265	60.5	36.5	20.5	44.5	103	20.5	21.5	12.5	109.5	500

KNURLED SCREW JACKS

1215 STEEL, CARBURIZED-HARDENED, BLACK OXIDE FINISH

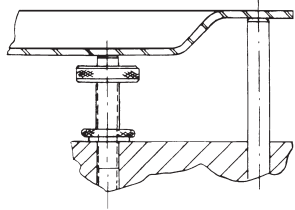

Knurled head allows quick, easy, finger adjustment. Order Knurled Check Nut separately.

INCH

PART NO.	A	B	C DIA	KNURLED CHECK NUT (NOT FURNISHED)
CL-0-KSJ	5/16-18	1-5/8	7/8	CL-51618-TSJN
CL-1-KSJ		1-1/4		
CL-2-KSJ	3/8-16	1-5/8	1-1/8	CL-3816-TSJN
CL-3-KSJ		2		
CL-4-KSJ		1-1/4		
CL-5-KSJ	1/2-13	1-5/8	1-1/8	CL-1213-TSJN
CL-6-KSJ		2		
CL-7-KSJ		2-1/2		
CL-8-KSJ		1-5/8		
CL-9-KSJ	5/8-11	2	1-3/8	CL-5811-TSJN
CL-10-KSJ		2-1/2		

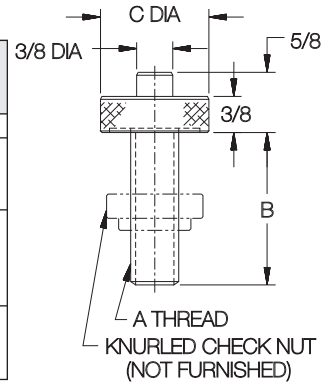

TORQUE SCREW JACKS

1215 STEEL, BLACK OXIDE FINISH



When indicated end force is reached, the knurled head disengages, eliminating the possibility of exerting excessive pressure on thinwall pieces. Furnished with Knurled Check Nut.

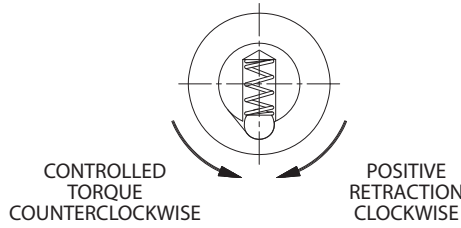

INCH

PART NO.	A	END FORCE (LBS)	B	C DIA	KNURLED CHECK NUT (FURNISHED)
CL-4-TSJ	1/4-20	12-14	7/16	7/8	CL-1420-TSJN
CL-4A-TSJ	5/16-18	14-16			CL-51618-TSJN
CL-5-TSJ	3/8-16	16-18	1/2	1-1/8	CL-3816-TSJN
CL-6-TSJ	1/2-13	18-20			CL-1213-TSJN
CL-8-TSJ	5/8-11	20-22			CL-5811-TSJN

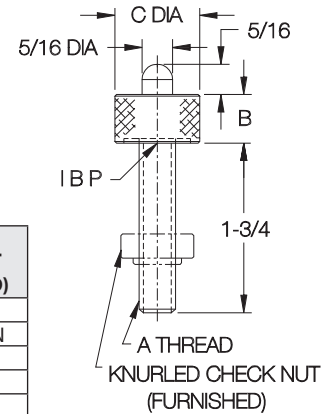

ADJUSTABLE LOCATING BUTTONS

1215 STEEL, CARBURIZED-HARDENED, BLACK OXIDE FINISH

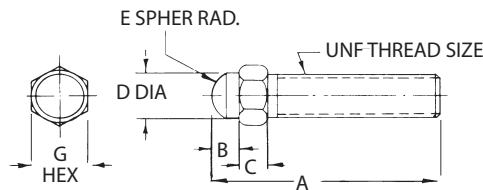

A support screw with fine threads for precise adjustment. (Metric threads and CL-LB-2A are coarse).

INCH

PART NO.	THREAD SIZE	A	B	C	D DIA	E	G
CL-LB-1	#10-32	1	1/8	1/8	3/16	1/8	1/4
CL-LB-2	1/4-28	1-1/2	3/16	3/16	1/4	3/16	3/8
CL-LB-2A	1/4-20						
CL-LB-7	5/16-24	1-3/4	1/4	1/4	5/16	3/16	7/16
CL-LB-3	3/8-24	2					
CL-LB-4	1/2-20	2-1/2	5/16	5/16	1/2	5/16	5/8
CL-LB-5	5/8-18	3	3/8	3/8	5/8	3/8	3/4
CL-LB-6	3/4-16	3-1/2	7/16	7/16	3/4	7/16	7/8

METRIC

CLM-5-LB	M5	.98	.12	.12	.20	.20	8mm
CLM-6-LB	M6	1.57	.20	.20	.24	.20	10mm
CLM-8-LB	M8	1.77	.24	.24	.31	.20	13mm
CLM-10-LB	M10	1.97			.39	.24	17mm
CLM-12-LB	M12	2.56	.31	.31	.47	.31	19mm
CLM-16-LB	M16	2.95	.39	.39	.63	.39	24mm

HEAVY-DUTY SCREW JACKS

JACK SCREW: 4135 STEEL, HEAT TREATED, BLACK OXIDE FINISH
 TIP: 1144 OR 1045 STEEL, HEAT TREATED, BLACK OXIDE FINISH
 BODY: 1045 STEEL, BLACK OXIDE FINISH

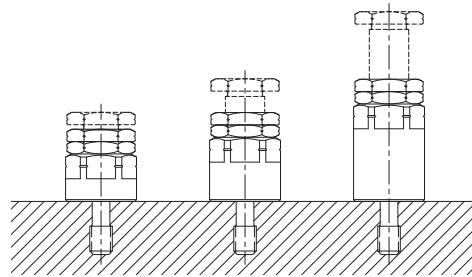
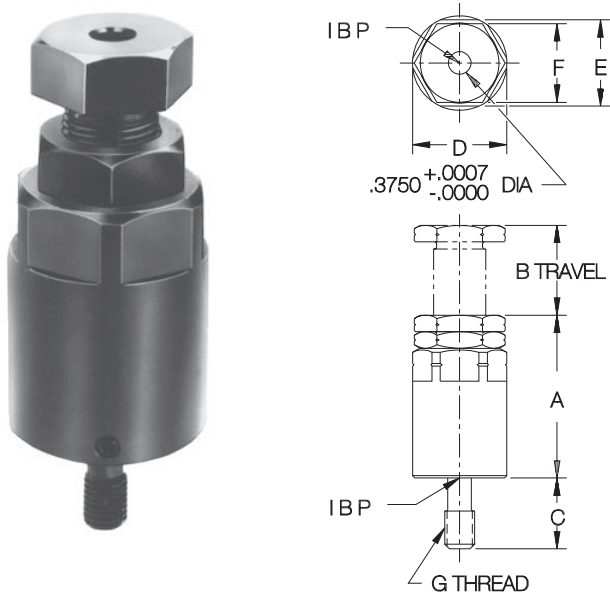

Heavy-duty adjustable support that accepts any of the three tips shown below. Choice of three heights in each size cover the full range of height possibilities.

SCREW JACKS (INCH)

PART NO.	MOUNTING SCREW SIZE	A	B	C	D DIA	E	F	G
CL-MF40-3401	1/2-13	1-5/8	3/8	1-1/4	1-9/16	1-7/16	1-5/16	1/2-13
CL-MF40-3402		2	3/4					
CL-MF40-3403		2-3/4	1-1/2					
CL-MF50-3401	5/8-11	1-5/8	3/8	1-3/8	1-9/16	1-7/16	1-5/16	5/8-11
CL-MF50-3402		2	3/4					
CL-MF50-3403		2-3/4	1-1/2					

SCREW JACKS (METRIC)

PART NO.	MOUNTING SCREW SIZE	A	B	C	D DIA	E	F	G
CL-MF12-3401	M12	1-5/8	3/8	1-1/4	1-9/16	1-7/16	1-5/16	M12
CL-MF12-3402		2	3/4					
CL-MF12-3403		2-3/4	1-1/2					
CL-MF16-3401	M16	1-5/8	3/8	1-3/8	1-9/16	1-7/16	1-5/16	M16
CL-MF16-3402		2	3/4					
CL-MF16-3403		2-3/4	1-1/2					

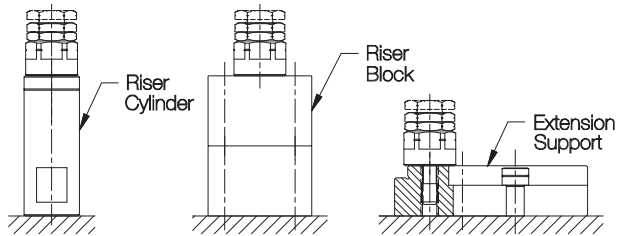

INFO+: For additional height and/or mounting flexibility, use Riser Cylinders (page 300), Support Riser Blocks (page 432), or Extension Supports (page 433).

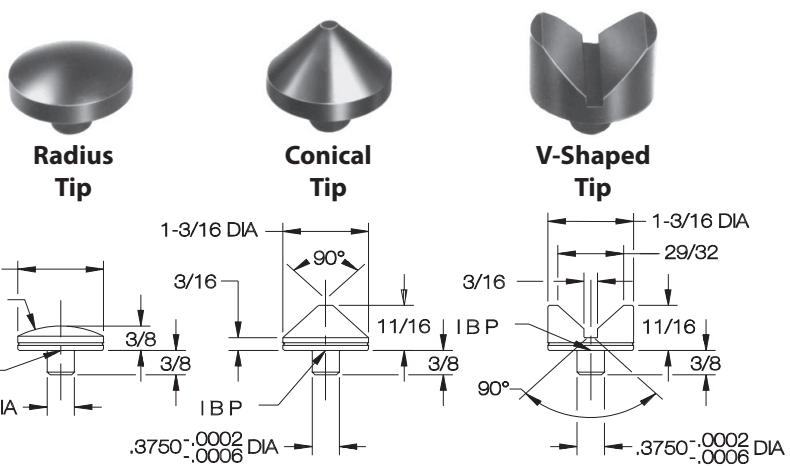
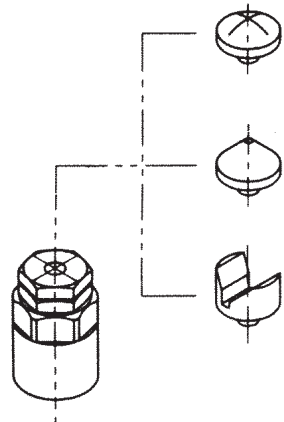

INFO+: Also see pages 637-640 for Roemheld hydraulically operated work supports.

SCREW-JACK TIPS

PART NO.	TYPE	FITS SCREW JACKS
CL-MF10-3501	RADIUS	ALL SIZES
CL-MF10-3502	CONICAL	
CL-MF10-3503	V-SHAPED	

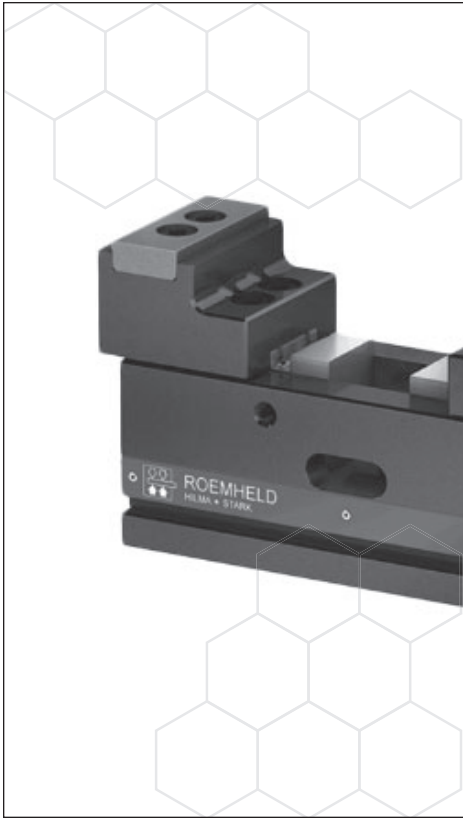

5-Axis Vises

Allows unrestricted tool access for multiple-side machining.

carrlane.com/cl5



5

Our Customer Service team is here to help



Ordering Information

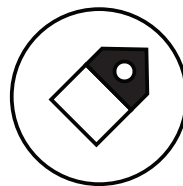

Price & Availability



Request A Quote



cs@carrlane.com
314.647.6200

THROUGH-HOLE LEVELING JACKS

4140 ALLOY STEEL, ZINC PLATED BLUE PASSIVATED

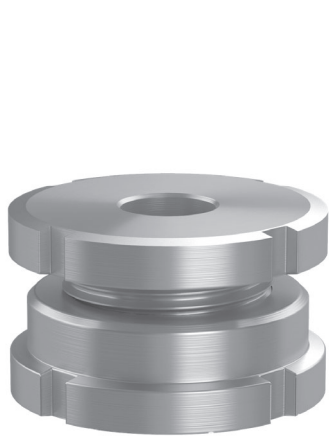

Short Version



Tall Version

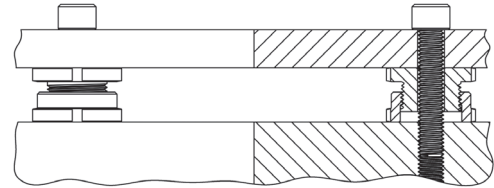

Clamping is achieved by tightening a bolt inserted through the workpiece and through the inside diameter of the leveling jack, after the desired level is set.

5

New item!

Through-Hole Leveling Jacks are designed for precise leveling at a desired clamping point. Clamping is achieved by tightening a bolt inserted through the workpiece and through the inside diameter of the leveling jack, after the desired level is set. The static load due to tightening the mounting bolt also securely locks the jack's rotation. These leveling jacks consist of a threaded upper sleeve and a tapered lower sleeve, with a fine thread that allows precise setting. An anti-rotation disk serves as a positive limiter for maximum height. A spanner wrench can be used for additional leverage.

The short version features an extremely low profile, higher load capacity, and a smaller height-adjustment range. The tall version provides a much greater adjustment range, while requiring additional support height and providing somewhat less load capacity. Both versions are available for 3/8", 1/2", and 5/8" bolt sizes (10, 12, and 16mm in metric).

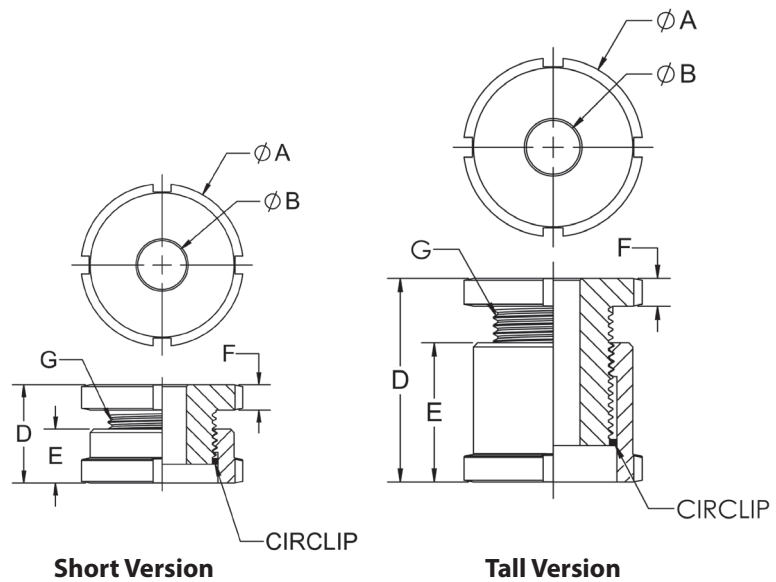

SHORT VERSION

PART NO.	FOR BOLT SIZE	HEIGHT ADJUSTMENT RANGE	A DIA	B DIA	D MIN	D MAX	E	F	G THREAD	MAXIMUM STATIC LOAD AFTER STANDARD BOLT PRELOAD (lbs)
CL-310-TLJS	3/8" or M10	.20	1.26	.43	.71	.91	.47	.24	M20x1	8500
CL-412-TLJS	1/2" or M12	.27	1.77	.53	.87	1.14	.59	.28	M30x1.5	18000
CL-516-TLJS	5/8" or M16	.35	2.28	.69	1.10	1.45	.75	.35	M40x1.5	30000

TALL VERSION

CL-310-TLJT	3/8" or M10	.79	1.26	.43	1.38	2.17	.47	.24	M20x1	5200
CL-412-TLJT	1/2" or M12	.98	1.77	.53	1.65	2.63	.59	.28	M30x1.5	12000
CL-516-TLJT	5/8" or M16	1.26	2.28	.69	2.13	3.39	.75	.35	M40x1.5	20000

HORIZONTAL V BLOCKS

1045 STEEL, HEAT TREATED, BLACK OXIDE FINISH

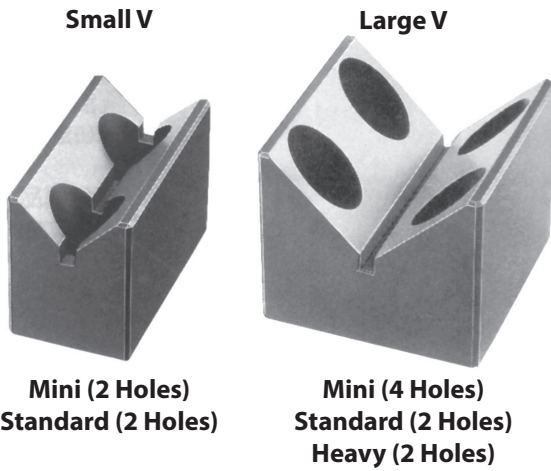

Extremely versatile locator for cylindrical workpieces. Locating surface is precision ground and accurately qualified with respect to the mounting holes. Two tapped holes in the side (standard and heavy sizes only) can be used to mount end stops or clamps. Available in two types: one for small diameters, and one for larger diameters. **INFO+**: Also see page 436 for Vertical V Blocks.

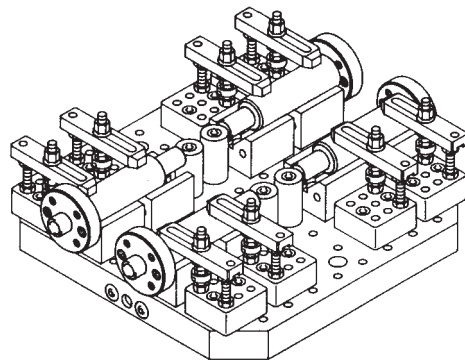

In the above example, Support Cylinders are used as end stops for shafts located in Horizontal V Blocks.

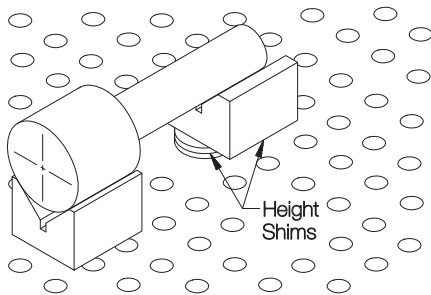

To locate a workpiece from two different diameters simultaneously, use Height Shims (**INFO+** page 423) to raise one V block to the proper level.

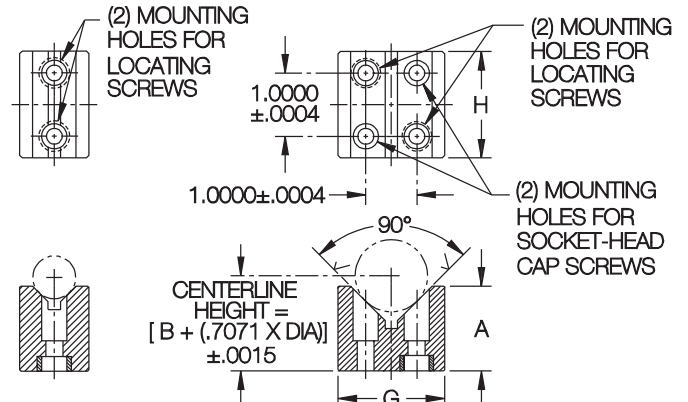

Mini—Small V

Mini—Large V

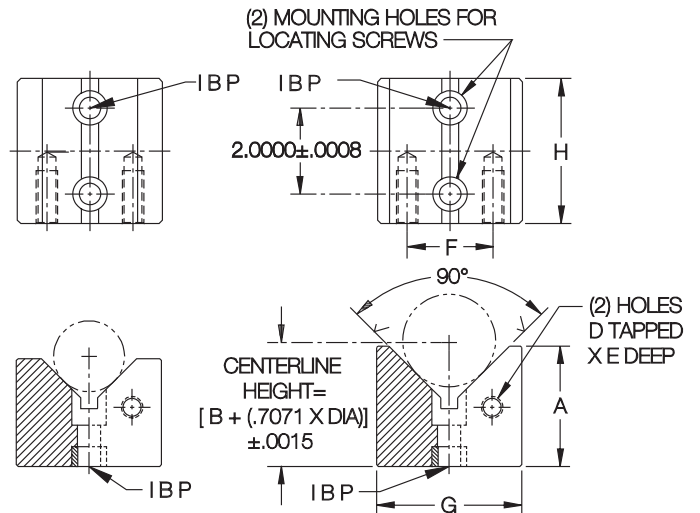

Standard—Small V

Standard—Large V
Heavy—Large V

SMALL V

SIZE	PART NO.	WORKPIECE DIAMETER RANGE	A	B	D	E	F	G	H	LOCATING SCREWS (2 REQD)	SOCKET-HEAD CAP SCREWS (0 OR 2 REQD)
MINI	CL-MF25-6001	3/8 to 1	1-1/4	.8750	—	—	—	1	1-3/4	CL-MF25-4300 + CL-5/16-18x1.38-SHCS	—
STANDARD	CL-MF40-6001	9/16 to 3-1/8	2-1/2	1.3951	1/2-13	1-1/8	2	3-3/8	3-3/8	CL-MF40-4302	—

LARGE V

MINI	CL-MF25-6002	9/16 to 2	1-1/2	.7500	—	—	—	1-3/4	1-3/4	CL-MF25-4300 + CL-5/16-18x1.38-SHCS	CL-5/16-18x1.38-SHCS
STANDARD	CL-MF40-6002	9/16 to 4	3	1.5858	1/2-13	1-1/8	2	3-3/8	3-3/8	CL-MF40-4302	—
HEAVY	CL-MF50-6002	9/16 to 4	3	1.5858	5/8-11	1-3/8	2	3-3/8	3-3/8	CL-MF50-4302	—

LOCATORS



Locating Pins



Construction Balls



Fixture Keys

6

Also see:



**Center Locating Keys
for Rotary Tables**
p. 382



Fixture Locating Pins
p. 416

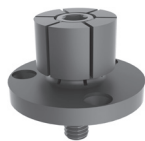

Internal Clamps
p. 308-309



Carr Lock® System
p. 358-372



**CL5® Quick-Change
5-Axis Workholding**
p. 373-394



Rest Buttons & Pads
p. 218-222

LOCATING PINS

TYPES



ROUND & DIAMOND PINS

Precision locating pins with a chamfered tip for easy part loading, and a shoulder to resist downward forces. Round Pins and Diamond Pins are frequently used together to locate from two holes in a workpiece, or align two pieces of a fixture, without binding.



ROUND & DIAMOND LOCATING PINS

Functionally similar to Round and Diamond Pins, except with a wider selection of head diameters (including any custom diameter from .1150" to 1.0400") and a large shoulder to resist downward forces. Frequently used together to locate from two holes in a workpiece without binding.



FLOATING LOCATING PINS

These locating pins slide in a slotted bushing to provide precise location in one axis while allowing considerable float in the perpendicular axis. Functionally similar to Diamond Pins, except that they allow greater variation in hole spacing.



BULLET-NOSE DOWELS

Precision locating pin often used with a mating bushing to align two pieces of a fixture.



BULLET-NOSE PINS

Bullet-nose round pins and diamond pins are often used together, each with a mating bushing, to align two pieces of a fixture. The pin's shank diameter and the bushing's OD are the same size, to allow boring the installation hole in both fixture pieces at the same time, for greater accuracy.



CONE-LOCATOR PINS

Medium-accuracy tapered locating pin used with a mating tapered bushing. Can be used for quick assembly of two fixture pieces.

6

TECHNICAL INFORMATION

Round Pins and Diamond Pins are frequently used together. Diamond Pins are relieved to locate only radially around the Round Pin, avoiding redundant location. This prevents binding while loading and unloading the part, yet still maintains high accuracy. The Round Pin serves as the primary, 2-axis locator, while the Diamond Pin is the secondary, 1-axis locator.

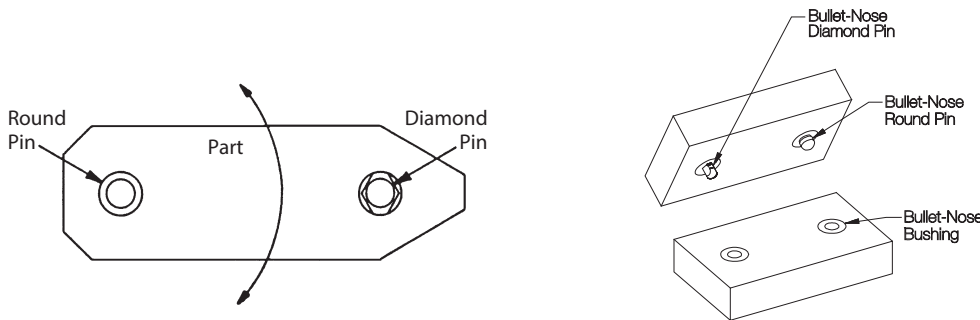

ROUND & DIAMOND PINS

1144 STEEL, HEAT TREATED RC 50-55 BLACK OXIDE FINISH



Round Pin



Diamond Pin

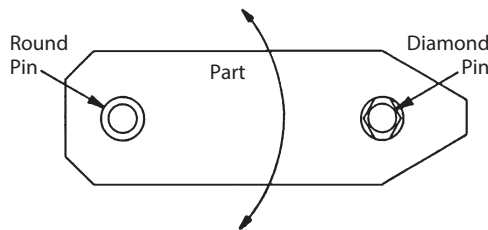
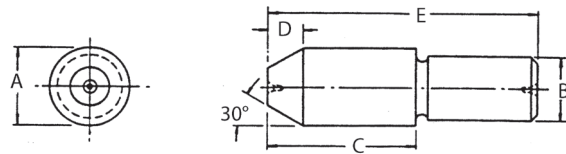

ROUND PINS (INCH)

PART NO.	A HEAD DIA		B SHANK DIA		C	D	E
	NOMINAL	ACTUAL	NOMINAL	ACTUAL			
CL-1-RP	1/4	.2495/.2492	3/16	.1878/.1876	11/32	3/32	3/4
CL-2-RP	5/16	.3120/.3117	1/4	.2503/.2501	13/32		7/8
CL-3-RP	3/8	.3745/.3742	5/16	.3128/.3126	1/2	1/8	1
CL-4-RP	7/16	.4370/.4367	3/8	.3753/.3751	19/32	5/32	1-1/4
CL-5-RP	1/2	.4995/.4992	7/16	.4378/.4376	21/32		1-3/8
CL-6-RP	9/16	.5620/.5617	1/2	.5003/.5001	3/4	3/16	1-1/2
CL-7-RP	5/8	.6240/.6237	9/16	.5628/.5626	27/32	7/32	1-3/4
CL-8-RP	11/16	.6865/.6862	5/8	.6253/.6251	29/32		2
CL-9-RP	3/4	.7490/.7487	11/16	.6885/.6880	1	1/4	2-1/8
CL-10-RP	13/16	.8115/.8112	3/4	.7510/.7505	1-3/32	9/32	2-1/4
CL-11-RP	7/8	.8740/.8737	13/16	.8135/.8130	1-5/32		2-1/2
CL-12-RP	15/16	.9365/.9362	7/8	.8760/.8755	1-1/4	5/16	2-3/4
CL-13-RP	1	.9985/.9980	15/16	.9385/.9380	1-5/16		2-7/8

ROUND PINS (METRIC)

PART NO.	A HEAD DIA	A HEAD DIA	B SHANK DIA	B SHANK DIA	C	D	E
	NOMINAL (mm)	ACTUAL (mm)	NOMINAL (mm)	ACTUAL (mm)			
CLM-60-RP	6	5.987 / 5.979	5	5.008 / 5.002	8.5	2.4	19
CLM-80-RP	8	7.987 / 7.979	6	6.008 / 6.002	10.5	2.4	22
CLM-100-RP	10	9.987 / 9.979	8	8.008 / 8.002	12.5	3.2	25.5
CLM-120-RP	12	11.987 / 11.979	10	10.008 / 10.002	16.5	4	35
CLM-140-RP	14	13.987 / 13.979	12	12.008 / 12.002	19	4.8	38
CLM-160-RP	16	15.975 / 15.967	14	14.008 / 14.002	21.5	5.5	44.5
CLM-180-RP	18	17.975 / 17.967	16	16.008 / 16.002	23	5.5	51
CLM-200-RP	20	19.975 / 19.967	18	18.026 / 18.012	28	7	57

These precision locating pins have a chamfered tip for easy part loading, and a shoulder to resist downward forces – important advantages over standard dowel pins. One Round Pin and one Diamond Pin are often used together to locate from two machined holes in a workpiece, or to align two pieces of a fixture, without binding. Diamond Pins are relieved, to locate in only 1 axis. Round Pins are also extremely useful as side locators. Head and shank diameters are concentric to within .0005" TIR. Available with head diameters from 1/4 to 1" (6 to 20mm in metric).

Also available with LIFE-EX® coating!

Many sizes of Round & Diamond Pins are available with our proprietary LIFE-EX® coating. This PVD coating is very hard, abrasion resistant, and slippery, resulting in a component that has a longer lifecycle for high-production applications. This extended lifecycle allows these items to remain in production longer with less need for replacement than standard uncoated items.

LIFE-EX® ROUND PINS (INCH)

PART NO.	A HEAD DIA		B SHANK DIA		C	D	E
	NOMINAL	ACTUAL	NOMINAL	ACTUAL			
CL-2-RP-LX	5/16	.3120/.3117	1/4	.2503/.2501	13/32	3/32	7/8
CL-3-RP-LX	3/8	.3745/.3742	5/16	.3128/.3126	1/2	1/8	1
CL-5-RP-LX	1/2	.4995/.4992	7/16	.4378/.4376	21/32	5/32	1-3/8

LIFE-EX® ROUND PINS (METRIC)

PART NO.	A HEAD DIA	A HEAD DIA	B SHANK DIA	B SHANK DIA	C	D	E
	NOMINAL (mm)	ACTUAL (mm)	NOMINAL (mm)	ACTUAL (mm)			
CLM-80-RP-LX	8	7.987 / 7.979	6	6.008 / 6.002	10.5	2.4	22
CLM-100-RP-LX	10	9.987 / 9.979	8	8.008 / 8.002	12.5	3.2	25.5
CLM-120-RP-LX	12	11.987 / 11.979	10	10.008 / 10.002	16.5	4	35

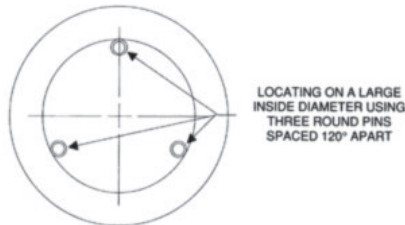

A series of locating pins can be used to locate a large diameter, instead of making a custom locating plug. In this example, three Round Pins are positioned 120° apart around the internal diameter of a large bored hole.

ROUND & DIAMOND PINS

1144 STEEL, HEAT TREATED RC 50-55 BLACK OXIDE FINISH

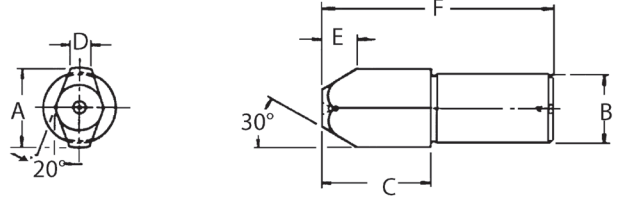

DIAMOND PINS (INCH)

PART NO.			A HEAD DIA				B SHANK DIA		C	D	E	F
X (Tight)	Y (Medium)	Z (Loose)	NOMINAL	X	Y	Z	NOMINAL	ACTUAL				
CL-1-DPX	CL-1-DPY	CL-1-DPZ	1/4	.2493/.2490	.2485/.2482	.2470/.2467	3/16	.1878/.1876	11/32	.062	3/32	3/4
CL-2-DPX	CL-2-DPY	CL-2-DPZ	5/16	.3118/.3115	.3110/.3107	.3095/.3092	1/4	.2503/.2501	13/32	.078		7/8
CL-3-DPX	CL-3-DPY	CL-3-DPZ	3/8	.3743/.3740	.3735/.3732	.3720/.3717	5/16	.3128/.3126	1/2	.093	1/8	1
CL-4-DPX	CL-4-DPY	CL-4-DPZ	7/16	.4368/.4365	.4360/.4357	.4345/.4342	3/8	.3753/.3751	19/32	.109	5/32	1-1/4
CL-5-DPX	CL-5-DPY	CL-5-DPZ	1/2	.4993/.4990	.4985/.4982	.4970/.4967	7/16	.4378/.4376	21/32	.125		1-3/8
CL-6-DPX	CL-6-DPY	CL-6-DPZ	9/16	.5615/.5610	.5595/.5590	.5575/.5570	1/2	.5003/.5001	3/4	.140	3/16	1-1/2
CL-7-DPX	CL-7-DPY	CL-7-DPZ	5/8	.6240/.6235	.6220/.6215	.6200/.6195	9/16	.5628/.5626	27/32	.156	7/32	1-3/4
CL-8-DPX	CL-8-DPY	CL-8-DPZ	11/16	.6865/.6860	.6845/.6840	.6825/.6820	5/8	.6253/.6251	29/32	.172		2
CL-9-DPX	CL-9-DPY	CL-9-DPZ	3/4	.7490/.7485	.7470/.7465	.7450/.7445	11/16	.6885/.6880	1	.187	1/4	2-1/8
CL-11-DPX	CL-11-DPY	CL-11-DPZ	7/8	.8740/.8735	.8720/.8715	.8700/.8695	13/16	.8135/.8130	1-5/32	.219	9/32	2-1/2
CL-13-DPX	CL-13-DPY	CL-13-DPZ	1	.9980/.9972	.9960/.9952	.9920/.9912	15/16	.9385/.9380	1-5/16	.250	5/16	2-7/8

DIAMOND PINS (METRIC)

PART NO.	A HEAD DIA NOMINAL (mm)	A HEAD DIA ACTUAL (mm)	B SHANK DIA NOMINAL (mm)	B SHANK DIA ACTUAL (mm)	C (mm)	D (mm)	E (mm)	F (mm)
CLM-60-DPX	6	5.982 / 5.974	5	5.008 / 5.002	8.5	1.57	2.4	19
CLM-60-DPY	6	5.961 / 5.954	5	5.008 / 5.002	8.5	1.57	2.4	19
CLM-60-DPZ	6	5.923 / 5.916	5	5.008 / 5.002	8.5	1.57	2.4	19
CLM-80-DPX	8	7.983 / 7.976	6	6.008 / 6.002	10.5	1.98	2.4	22
CLM-80-DPY	8	7.963 / 7.955	6	6.008 / 6.002	10.5	1.98	2.4	22
CLM-80-DPZ	8	7.925 / 7.917	6	6.008 / 6.002	10.5	1.98	2.4	22
CLM-100-DPX	10	9.982 / 9.975	8	8.008 / 8.002	12.5	2.36	3.2	25.5
CLM-100-DPY	10	9.962 / 9.954	8	8.008 / 8.002	12.5	2.36	3.2	25.5
CLM-100-DPZ	10	9.924 / 9.916	8	8.008 / 8.002	12.5	2.36	3.2	25.5
CLM-120-DPX	12	11.981 / 11.974	10	10.008 / 10.002	16.5	3.18	4	35
CLM-120-DPY	12	11.961 / 11.953	10	10.008 / 10.002	16.5	3.18	4	35
CLM-120-DPZ	12	11.923 / 11.915	10	10.008 / 10.002	16.5	3.18	4	35
CLM-140-DPX	14	13.975 / 13.962	12	12.008 / 12.002	19	3.56	4.8	38
CLM-140-DPY	14	13.924 / 13.912	12	12.008 / 12.002	19	3.56	4.8	38
CLM-140-DPZ	14	13.873 / 13.861	12	12.008 / 12.002	19	3.56	4.8	38
CLM-160-DPX	16	15.974 / 15.961	14	14.008 / 14.002	21.5	3.96	5.5	44.5
CLM-160-DPY	16	15.923 / 15.910	14	14.008 / 14.002	21.5	3.96	5.5	44.5
CLM-160-DPZ	16	15.872 / 15.860	14	14.008 / 14.002	21.5	3.96	5.5	44.5
CLM-180-DPX	18	17.976 / 17.963	16	16.008 / 16.002	23	4.37	5.5	51
CLM-180-DPY	18	17.925 / 17.912	16	16.008 / 16.002	23	4.37	5.5	51
CLM-180-DPZ	18	17.874 / 17.861	16	16.008 / 16.002	23	4.37	5.5	51
CLM-200-DPX	20	19.974 / 19.962	18	18.026 / 18.012	28	5.16	7	57
CLM-200-DPY	20	19.924 / 19.911	18	18.026 / 18.012	28	5.16	7	57
CLM-200-DPZ	20	19.873 / 19.860	18	18.026 / 18.012	28	5.16	7	57

Also available with LIFE-EX® coating!

Many sizes of Round & Diamond Pins are available with our proprietary LIFE-EX® coating. This PVD coating is very hard, abrasion resistant, and slippery, resulting in a component that has a longer lifecycle for high-production applications. This extended lifecycle allows these items to remain in production longer with less need for replacement than standard uncoated items.

LIFE-EX® DIAMOND PINS (INCH)

PART NO.			A HEAD DIA				B SHANK DIA		C	D	E	F
X (Tight)	Y (Medium)	Z (Loose)	NOMINAL	X	Y	Z	NOMINAL	ACTUAL				
CL-2-DPX-LX	—	—	5/16	.3118/.3115	.3110/.3107	.3095/.3092	1/4	.2503/.2501	13/32	.078	3/32	7/8
CL-3-DPX-LX	—	—	3/8	.3743/.3740	.3735/.3732	.3720/.3717	5/16	.3128/.3126	1/2	.093	1/8	1
CL-5-DPX-LX	—	—	1/2	.4993/.4990	.4985/.4982	.4970/.4967	7/16	.4378/.4376	21/32	.125	5/32	1-3/8

LIFE-EX® DIAMOND PINS (METRIC)

CLM-60-DPX-LX	—	—	6mm	.2357/.2354	.2347/.2344	.2332/.2329	5mm	.1972/.1970	11/32	.062	3/32	3/4
CLM-80-DPX-LX	—	—	8mm	.3145/.3142	.3135/.3132	.3120/.3117	6mm	.2365/.2363	13/32	.078		7/8
CLM-100-DPX-LX	—	—	10mm	.3932/.3929	.3922/.3919	.3907/.3904	8mm	.3153/.3151	1/2	.093	1/8	1

ROUND & DIAMOND LOCATING PINS

1144 STEEL, HEAT TREATED RC 50-55, BLACK OXIDE FINISH



**Press-Fit Type
Round Pin**

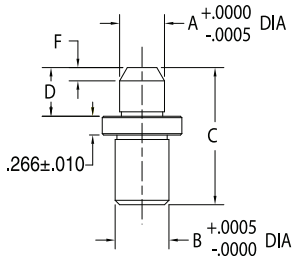
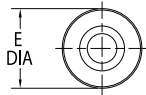

**Press-Fit Type
Diamond Pin**

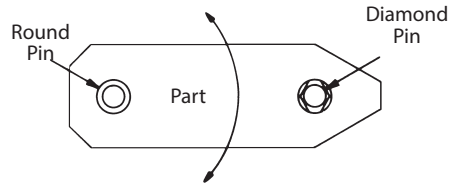
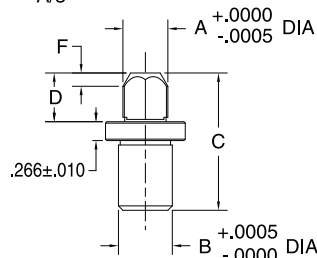
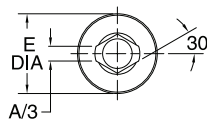

These precision locating pins are especially useful for workpiece location because of the wide selection of head diameters available to fit machined holes in the part. In addition to standard diameters, these pins are also quickly made to order in any special head diameter from .1150" to 1.0400" in .0001" increments. One Round Locating Pin and one Diamond Locating Pin is relieved to locate in only 1 axis. The type shown here, with a press-fit shank, is designed for permanent installation.

Round & Diamond Locating Pins are available in four standard shank diameters, each with a range of standard head diameters in 1/32" increments (2mm increments in metric), each available in either standard or undersize fit. Head and shank diameters are concentric to within .0005" TIR. Made in USA.

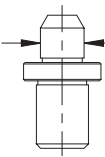

Special head diameters (A dimensions) are readily available in any of the four standard shank diameters:

- 5 = 5/16" shank (.1150-.3180 head dia)
- 8 = 1/2" shank (.2780-.5040 head dia)
- 12 = 3/4" shank (.4640-.7540 head dia)
- 16 = 1" shank (.7140-1.0040 head dia)

Example: For a press-fit round pin with a 1/2-inch shank and A=.4000 inches, order CL-8-RPT-.4000.

PRESS-FIT TYPE (INCH)

ROUND PIN PART NO.	DIAMOND PIN PART NO.	B SHANK DIA	A HEAD DIA		C	D	E DIA	F
			NOMINAL	ACTUAL				
CL-123-RPT	CL-123-DPT	5/16	1/8	.1235	1-3/16	7/16	5/8	3/32
CL-124-RPT	CL-124-DPT			.1245				
CL-154-RPT	CL-154-DPT		5/32	.1548				
CL-155-RPT	CL-155-DPT			.1558				
CL-186-RPT	CL-186-DPT		3/16	.1860				
CL-187-RPT	CL-187-DPT			.1870				
CL-217-RPT	CL-217-DPT		7/32	.2173				
CL-218-RPT	CL-218-DPT			.2183				
CL-248-RPT	CL-248-DPT		1/4	.2485				
CL-249-RPT	CL-249-DPT			.2495				
CL-279-RPT	CL-279-DPT		9/32	.2798				
CL-280-RPT	CL-280-DPT			.2808				
CL-311-RPT	CL-311-DPT	5/16	.3110					
CL-312-RPT	CL-312-DPT		.3120					
CL-310-RPT	CL-310-DPT	1/2	5/16	.3105	1-1/2	1/2	7/8	1/8
CL-3115-RPT	CL-3115-DPT			.3115				
CL-341-RPT	CL-341-DPT		11/32	.3418				
CL-342-RPT	CL-342-DPT			.3428				
CL-373-RPT	CL-373-DPT		3/8	.3730				
CL-374-RPT	CL-374-DPT			.3740				
CL-404-RPT	CL-404-DPT		13/32	.4043				
CL-405-RPT	CL-405-DPT			.4053				
CL-435-RPT	CL-435-DPT		7/16	.4355				
CL-436-RPT	CL-436-DPT			.4365				
CL-466-RPT	CL-466-DPT		15/32	.4668				
CL-467-RPT	CL-467-DPT			.4678				
CL-498-RPT	CL-498-DPT	1/2	.4980					
CL-499-RPT	CL-499-DPT		.4990					

CONTINUED ON NEXT PAGE

ROUND & DIAMOND LOCATING PINS

ROUND PIN PART NO.	DIAMOND PIN PART NO.	B SHANK DIA	A HEAD DIA		C	D	E DIA	F					
			NOMINAL	ACTUAL									
CONTINUED FROM PREVIOUS PAGE													
CL-4980-RPT	CL-4980-DPT	3/4	1/2	.4980	1-15/16	11/16	1-1/8	3/16					
CL-4990-RPT	CL-4990-DPT			.4990									
CL-529-RPT	CL-529-DPT		17/32	.5293									
CL-530-RPT	CL-530-DPT			.5303									
CL-560-RPT	CL-560-DPT		9/16	.5605									
CL-561-RPT	CL-561-DPT			.5615									
CL-591-RPT	CL-591-DPT		19/32	.5918									
CL-592-RPT	CL-592-DPT			.5928									
CL-623-RPT	CL-623-DPT		5/8	.6230									
CL-624-RPT	CL-624-DPT			.6240									
CL-654-RPT	CL-654-DPT		21/32	.6543									
CL-655-RPT	CL-655-DPT			.6553									
CL-685-RPT	CL-685-DPT		11/16	.6855									
CL-686-RPT	CL-686-DPT			.6865									
CL-716-RPT	CL-716-DPT		23/32	.7168									
CL-717-RPT	CL-717-DPT			.7178									
CL-748-RPT	CL-748-DPT		3/4	.7480									
CL-749-RPT	CL-749-DPT			.7490									
CL-7480-RPT	CL-7480-DPT		1	3/4					.7480	2-5/8	1	1-1/2	9/32
CL-7490-RPT	CL-7490-DPT								.7490				
CL-779-RPT	CL-779-DPT	25/32		.7793									
CL-780-RPT	CL-780-DPT			.7803									
CL-810-RPT	CL-810-DPT	13/16		.8105									
CL-811-RPT	CL-811-DPT			.8115									
CL-841-RPT	CL-841-DPT	27/32		.8418									
CL-842-RPT	CL-842-DPT			.8428									
CL-873-RPT	CL-873-DPT	7/8		.8730									
CL-874-RPT	CL-874-DPT			.8740									
CL-904-RPT	CL-904-DPT	29/32		.9043									
CL-905-RPT	CL-905-DPT			.9053									
CL-935-RPT	CL-935-DPT	15/16		.9355									
CL-936-RPT	CL-936-DPT			.9365									
CL-966-RPT	CL-966-DPT	31/32		.9668									
CL-967-RPT	CL-967-DPT			.9678									
CL-998-RPT	CL-998-DPT	1		.9980									
CL-999-RPT	CL-999-DPT			.9990									

6

PRESS-FIT TYPE (METRIC)

PART NO.	B SHANK DIA	A DIA NOMINAL (mm)	A DIA ACTUAL (mm)	C (mm)	D (mm)	E DIA (mm)	F (mm)
CL-5-RPT-.2347	5/16"	6	5.961	30	11	16	2.4
CL-5-RPT-.2357			5.987				
CL-8-RPT-.3130	1/2"	8	7.950	38	12.5	22	3.2
CL-8-RPT-.3140			7.976				
CL-8-RPT-.3917		10	9.949				
CL-8-RPT-.3927			9.974				
CL-8-RPT-.4704		12	11.948				
CL-8-RPT-.4714			11.974				
CL-12-RPT-.5492	3/4"	14	13.950	49	17.5	28.5	4.8
CL-12-RPT-.5502			13.975				
CL-12-RPT-.6279		16	15.949				
CL-12-RPT-.6289			15.974				
CL-12-RPT-.7067		18	17.950				
CL-12-RPT-.7077			17.976				
CL-16-RPT-.7854	1"	20	19.949	66.5	25.5	38	7
CL-16-RPT-.7864			19.974				

ROUND & DIAMOND LOCATING PINS

1144 STEEL, HEAT TREATED RC 50-55, BLACK OXIDE FINISH



**Lockscrew-Type
Round Pin**

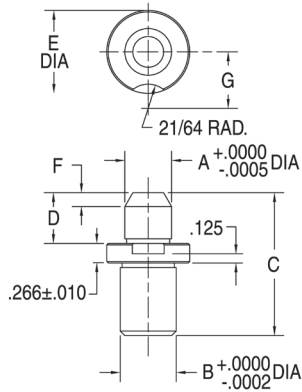

**Lockscrew-Type
Diamond Pin**

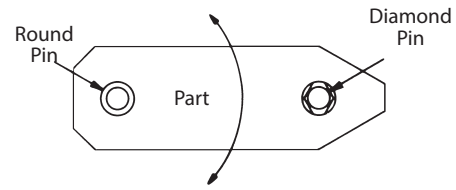
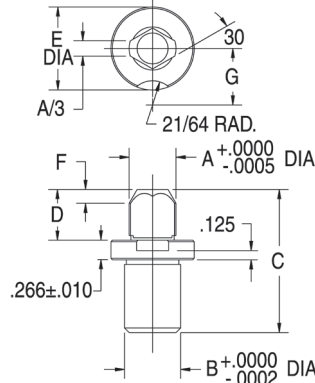

These precision locating pins are especially useful for workpiece location because of the wide selection of head diameters available to fit machined holes in the part. In addition to standard diameters, these pins are also quickly made to order in any special head diameter from .1150" to 1.0400" in .0001" increments. One Round Locating Pin and one Diamond Locating Pin is relieved to locate in only 1 axis. The type shown here, with a slip-fit shank and lockscrew slot, is designed for renewable installation.

Round & Diamond Locating Pins are available in four standard shank diameters, each with a range of standard head diameters in 1/32" increments (2mm increments in metric), each available in either standard or undersize fit. Head and shank diameters are concentric to within .0005" TIR. Made in USA.

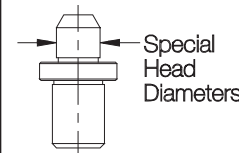

Special head diameters (A dimensions) are readily available in any of the four standard shank diameters:

- 5 = 5/16" shank (.1150-.3180 head dia)
- 8 = 1/2" shank (.2780-.5040 head dia)
- 12 = 3/4" shank (.4640-.7540 head dia)
- 16 = 1" shank (.7140-1.0040 head dia)

Example: For a press-fit round pin with a 1/2-inch shank and A=.4000 inches, order CL-8-RLT-4000.

LOCKSCREW TYPE (INCH)

ROUND PIN PART NO.	DIAMOND PIN PART NO.	B SHANK DIA	A HEAD DIA		C	D	E DIA	F	G	LINER PART NO.	HEAD LINER PART NO.	LOCK- SCREW PART NO.												
			NOMINAL	ACTUAL																				
CL-123-RLT	CL-123-DLT	5/16	1/8	.1235	1-3/16	7/16	5/8	3/32	33/64	L-32-8	HL-32-8	LS-1												
CL-124-RLT	CL-124-DLT			.1245																				
CL-154-RLT	CL-154-DLT			.1548																				
CL-155-RLT	CL-155-DLT		3/16	5/32									.1558											
CL-186-RLT	CL-186-DLT												.1860											
CL-187-RLT	CL-187-DLT												.1870											
CL-217-RLT	CL-217-DLT		1/2	13/32									.2173	1-1/2	1/2	7/8	1/8	41/64	L-48-12	HL-48-12	LS-1			
CL-218-RLT	CL-218-DLT												.2183											
CL-248-RLT	CL-248-DLT												.2485											
CL-249-RLT	CL-249-DLT												7/16									3/8	.2495	
CL-279-RLT	CL-279-DLT																						.2798	
CL-280-RLT	CL-280-DLT																						.2808	
CL-311-RLT	CL-311-DLT	1			15/32	.3110	1	1	1	1	1	1	1									1		
CL-312-RLT	CL-312-DLT					.3120																		
CL-310-RLT	CL-310-DLT					.3105																		
CL-3115-RLT	CL-3115-DLT					.3115																		
CL-341-RLT	CL-341-DLT					3/8																	11/32	.3418
CL-342-RLT	CL-342-DLT																							.3428
CL-373-RLT	CL-373-DLT		.3730																					
CL-374-RLT	CL-374-DLT		1/2	7/16		.3740																		
CL-404-RLT	CL-404-DLT					.4043																		
CL-405-RLT	CL-405-DLT					.4053																		
CL-435-RLT	CL-435-DLT		15/32	1/2		.4355																		
CL-436-RLT	CL-436-DLT					.4365																		
CL-466-RLT	CL-466-DLT	.4668																						
CL-467-RLT	CL-467-DLT	1/2	1/2	.4678																				
CL-498-RLT	CL-498-DLT			.4980																				
CL-499-RLT	CL-499-DLT			.4990																				

CONTINUED ON NEXT PAGE

ROUND & DIAMOND LOCATING PINS

ROUND PIN PART NO.	DIAMOND PIN PART NO.	B SHANK DIA	A HEAD DIA		C	D	E DIA	F	G	LINER PART NO.	HEAD LINER PART NO.	LOCK- SCREW PART NO.
			NOMINAL	ACTUAL								

CONTINUED FROM PREVIOUS PAGE

CL-4980-RLT	CL-4980-DLT	3/4	1/2	.4980	1-15/16	11/16	1-1/8	3/16	49/64	L-64-16	HL-64-16	LS-1
CL-4990-RLT	CL-4990-DLT			.4990								
CL-529-RLT	CL-529-DLT		17/32	.5293								
CL-530-RLT	CL-530-DLT			.5303								
CL-560-RLT	CL-560-DLT		9/16	.5605								
CL-561-RLT	CL-561-DLT			.5615								
CL-591-RLT	CL-591-DLT		19/32	.5918								
CL-592-RLT	CL-592-DLT			.5928								
CL-623-RLT	CL-623-DLT		5/8	.6230								
CL-624-RLT	CL-624-DLT			.6240								
CL-654-RLT	CL-654-DLT		21/32	.6543								
CL-655-RLT	CL-655-DLT			.6553								
CL-685-RLT	CL-685-DLT		11/16	.6855								
CL-686-RLT	CL-686-DLT			.6865								
CL-716-RLT	CL-716-DLT		23/32	.7168								
CL-717-RLT	CL-717-DLT			.7178								
CL-748-RLT	CL-748-DLT		3/4	.7480								
CL-749-RLT	CL-749-DLT			.7490								
CL-7480-RLT	CL-7480-DLT	1	3/4	.7480	2-5/8	1	1-1/2	9/32	61/64	L-88-22	HL-88-22	LS-1
CL-7490-RLT	CL-7490-DLT			.7490								
CL-779-RLT	CL-779-DLT		25/32	.7793								
CL-780-RLT	CL-780-DLT			.7803								
CL-810-RLT	CL-810-DLT		13/16	.8105								
CL-811-RLT	CL-811-DLT			.8115								
CL-841-RLT	CL-841-DLT		27/32	.8418								
CL-842-RLT	CL-842-DLT			.8428								
CL-873-RLT	CL-873-DLT		7/8	.8730								
CL-874-RLT	CL-874-DLT			.8740								
CL-904-RLT	CL-904-DLT		29/32	.9043								
CL-905-RLT	CL-905-DLT			.9053								
CL-935-RLT	CL-935-DLT		15/16	.9355								
CL-936-RLT	CL-936-DLT			.9365								
CL-966-RLT	CL-966-DLT		31/32	.9668								
CL-967-RLT	CL-967-DLT			.9678								
CL-998-RLT	CL-998-DLT		1	.9980								
CL-999-RLT	CL-999-DLT			.9990								

6

LOCKSCREW TYPE (METRIC)

PART NO.	B SHANK DIA	A DIA NOMINAL (mm)	A DIA ACTUAL (mm)	C (mm)	D (mm)	E DIA (mm)	F (mm)	G (mm)
CL-5-RLT-2347	5/16"	6	5.961	30	11	16	2.4	13
CL-5-RLT-2357	5/16"	6	5.987	30	11	16	2.4	13
CL-8-RLT-3130	1/2"	8	7.950	38	12.5	22	3.2	16.5
CL-8-RLT-3140	1/2"	8	7.976	38	12.5	22	3.2	16.5
CL-8-RLT-3917	1/2"	10	9.949	38	12.5	22	3.2	16.5
CL-8-RLT-3927	1/2"	10	9.974	38	12.5	22	3.2	16.5
CL-8-RLT-4704	1/2"	12	11.948	38	12.5	22	3.2	16.5
CL-8-RLT-4714	1/2"	12	11.974	38	12.5	22	3.2	16.5
CL-12-RLT-5492	3/4"	14	13.950	49	17.5	28.5	4.8	19.5
CL-12-RLT-5502	3/4"	14	13.975	49	17.5	28.5	4.8	19.5
CL-12-RLT-6279	3/4"	16	15.949	49	17.5	28.5	4.8	19.5
CL-12-RLT-6289	3/4"	16	15.974	49	17.5	28.5	4.8	19.5
CL-12-RLT-7067	3/4"	18	17.950	49	17.5	28.5	4.8	19.5
CL-12-RLT-7077	3/4"	18	17.976	49	17.5	28.5	4.8	19.5
CL-16-RLT-7854	1"	20	19.949	66.5	25.5	38	7	24
CL-16-RLT-7864	1"	20	19.974	66.5	25.5	38	7	24

Order liner bushing and lock screws separately. See table above for proper sizes. (See drill-bushing catalog section for additional dimensions).



ROUND & DIAMOND LOCATING PINS DIN 6321

A2 TOOL STEEL, HEAT TREATED, BLACK OXIDE FINISH

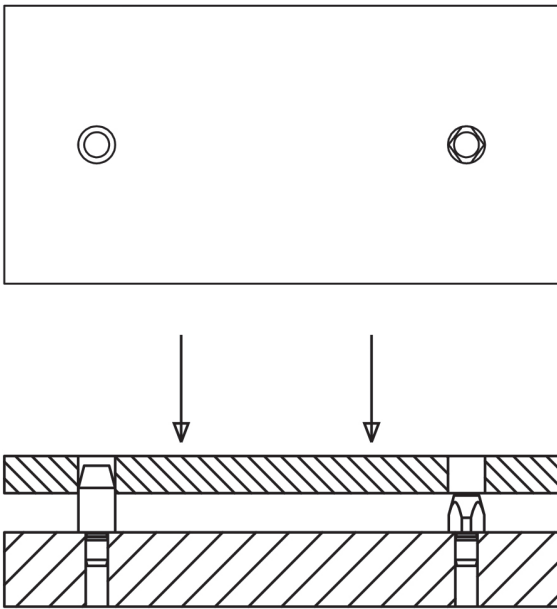

In this application, a Round Locating Pin (Type B, tall version) is used together with a Diamond Locating Pin (Type C, short version) to locate from two holes in a workpiece. Using a taller round pin allows smoother loading because that pin's hole can be fully engaged first, making it easier to engage the second hole.

New item!

DIN 6321 is a system of locating pins designed for hole location, side location, and supporting. These locating pins are available in three distinct types:

- Type A Round Locating Pads are dual-purpose precision locators, with a ground top surface for use as a rest pad, and a ground head diameter for use as a locating pin.
- Type B Round Locating Pins have a ground head diameter for use as a hole locator or for side location
- Type C Diamond Locating Pins also have a ground head diameter for use as a hole locator, but are relieved to locate in only 1 axis

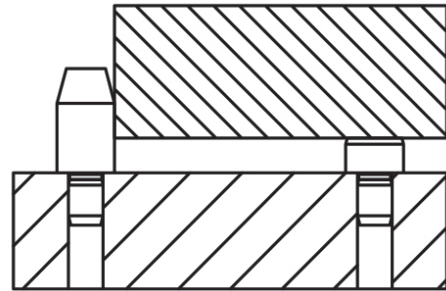

In this application, a Round Locating Pin (Type B) is used as a side locator, together with a Round Locating Pad (Type A) used as a rest pad.



**Round Locating Pads
DIN 6321
Type A**

Round Locating Pads per DIN 6321 Type A are dual-purpose precision locators, with a ground top surface for use as a rest pad, and a ground head diameter for use as a locating pin. These pads are especially useful as locating pins for side location of thin workpieces. Available with head diameters from 6 to 25mm.

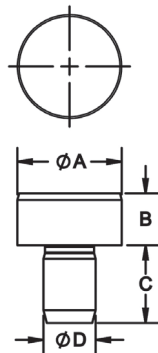

ROUND LOCATING PADS, TYPE A (METRIC)

PART NO.	A DIA (mm) g6	B (mm) h9	C (mm)	D (mm) n6
CL-6321-6-5-A	6	5	6	4
CL-6321-10-6-A	10	6	9	6
CL-6321-16-8-A	16	8	12	8
CL-6321-25-10-A	25	10	18	12

ROUND & DIAMOND LOCATING PINS DIN 6321

A2 TOOL STEEL, HEAT TREATED, BLACK OXIDE FINISH



**Round Locating Pins
DIN 6321
Type B
(Tall and Short)**

Round Locating Pins per DIN 6321 Type B have a ground head diameter for use as a hole locator or for side location. One Round Locating Pin and one Diamond Locating Pin are often used together to locate from two machined holes in a workpiece, or to align two pieces of a fixture, without binding. Round Locating Pins are also extremely useful as side locators. Head and shank diameters are concentric to within .0005" TIR. Available with head diameters from 6 to 25mm, each in a tall and a short version.

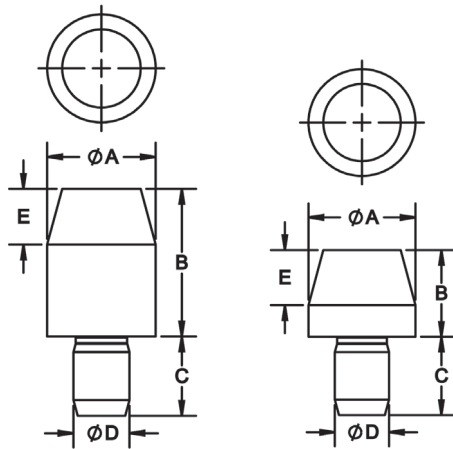

ROUND LOCATING PINS, TYPE B (METRIC)

PART NO.	A DIA (mm) g6	VERSION	B (mm)	C (mm)	D DIA (mm) n6	E (mm)
CL-6321-6-7-B	6	Short	7	6	4	4
CL-6321-6-12-B		Tall	12			
CL-6321-8-10-B	8	Short	10	9	6	6
CL-6321-8-16-B		Tall	16			
CL-6321-10-10-B	10	Short	10	9	6	6
CL-6321-10-18-B		Tall	18			
CL-6321-12-10-B	12	Short	10	9	6	6
CL-6321-12-18-B		Tall	18			
CL-6321-16-13-B	16	Short	13	12	8	8
CL-6321-16-22-B		Tall	22			
CL-6321-20-15-B	20	Short	15	18	12	9
CL-6321-20-25-B		Tall	25			
CL-6321-25-15-B	25	Short	15	18	12	9
CL-6321-25-25-B		Tall	25			



**Diamond Locating Pins
DIN 6321
Type C
(Tall and Short)**

Diamond Locating Pins per DIN 6321 Type C also have a ground head diameter for use as a hole locator, but are relieved to locate in only 1 axis. One Round Locating Pin and one Diamond Locating Pin are often used together to locate from two machined holes in a workpiece, or to align two pieces of a fixture, without binding. Head and shank diameters are concentric to within .0005" TIR. Available with head diameters from 6 to 25mm, each in a tall and a short version.

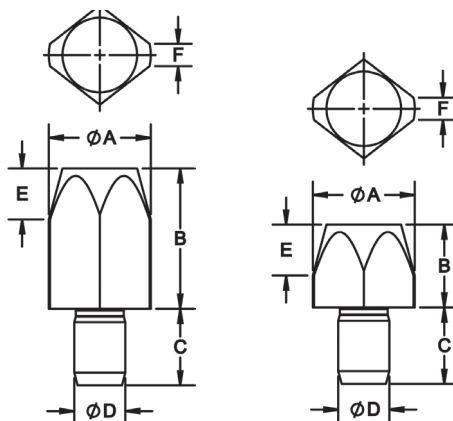

DIAMOND LOCATING PINS, TYPE C (METRIC)

PART NO.	A DIA (mm) g6	VERSION	B (mm)	C (mm)	D DIA (mm) n6	E (mm)	F (mm)
CL-6321-6-7-C	6	Short	7	6	4	4	1
CL-6321-6-12-C		Tall	12				
CL-6321-8-10-C	8	Short	10	9	6	6	1.6
CL-6321-8-16-C		Tall	16				
CL-6321-10-10-C	10	Short	10	9	6	6	2.5
CL-6321-10-18-C		Tall	18				
CL-6321-12-10-C	12	Short	10	9	6	6	2.5
CL-6321-12-18-C		Tall	18				
CL-6321-16-13-C	16	Short	13	12	8	8	3.5
CL-6321-16-22-C		Tall	22				
CL-6321-20-15-C	20	Short	15	18	12	9	5
CL-6321-20-25-C		Tall	25				
CL-6321-25-15-C	25	Short	15	18	12	9	5
CL-6321-25-25-C		Tall	25				

FLOATING LOCATING PINS

BODY: TOOL STEEL, HEAT TREATED, BLACK OXIDE FINISH
 PIN: 1144 STEEL, HEAT TREATED, BLACK OXIDE FINISH



Provides precise location in one axis while allowing considerable float in the perpendicular axis. Use in conjunction with a Round Pin when loose workpiece-hole tolerances require more float than a Diamond Pin would allow. Special pin diameters (A dimensions) are available. Please contact factory.

Patent no. 3,381,554.

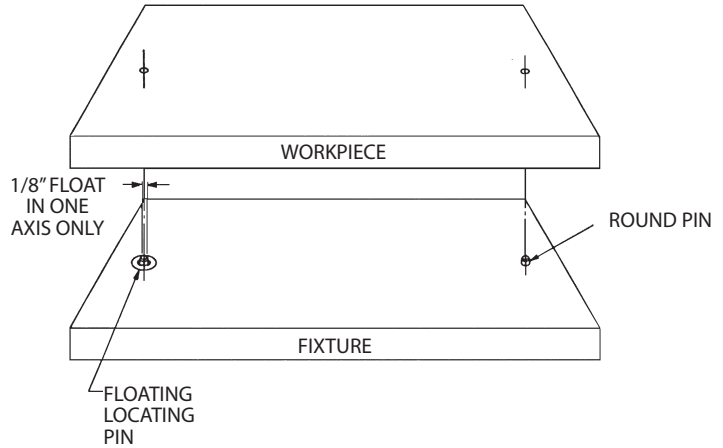

6

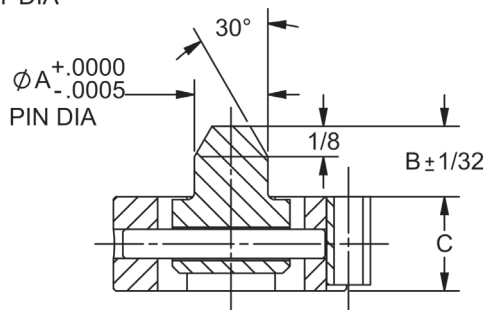
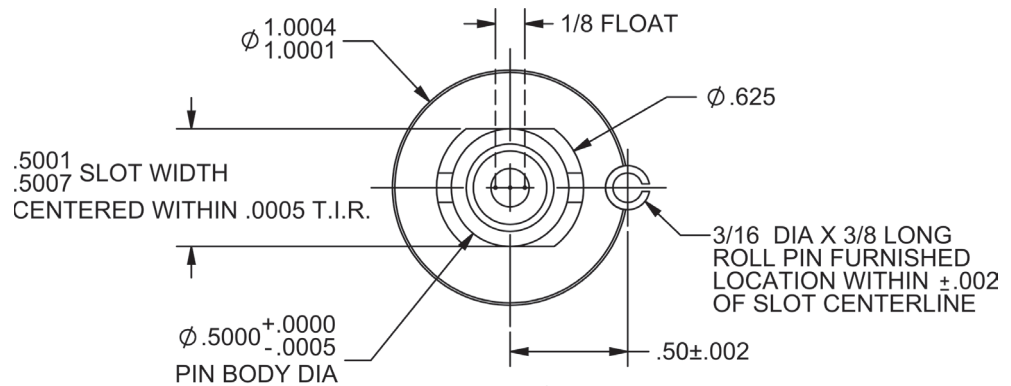
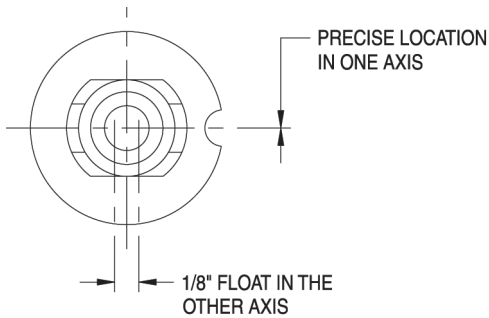

INCH

PART NO.	A DIA	B	C
CL-4-FLP	.2500	.300	.400
CL-5-FLP	.3125	.300	.400
CL-6-FLP	.3750	.300	.400
CL-8-FLP	.5000	.300	.400
CL-10-FLP	.6250	.310	.400

BULLET-NOSE PINS

1144 STEEL, HEAT TREATED RC 50-62, BLACK OXIDE FINISH

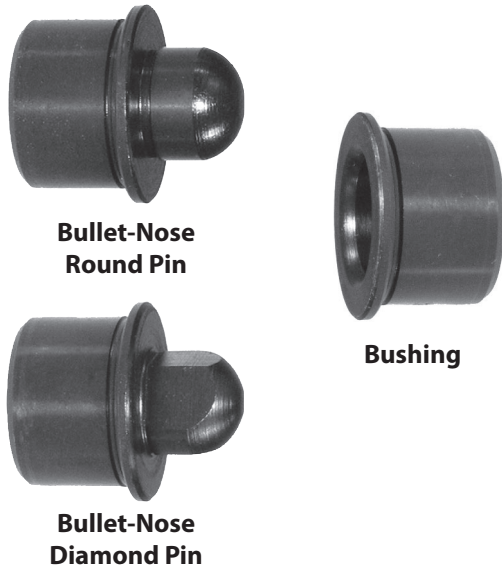

Bullet-Nose Round Pins and Diamond Pins are often used together (with matching bushings) to align two pieces of a fixture. The Diamond Pin is relieved, to locate only radially around the round pin, avoiding redundant location. This prevents binding, yet still maintains high accuracy.

The pin's shank diameter and the bushing's OD are the same size to allow boring the installation hole in both fixture pieces at the same time, for greater accuracy. The pin's head and shank diameters are concentric to within .0005 TIR. The bushing's ID and OD are concentric to within .0003 TIR.

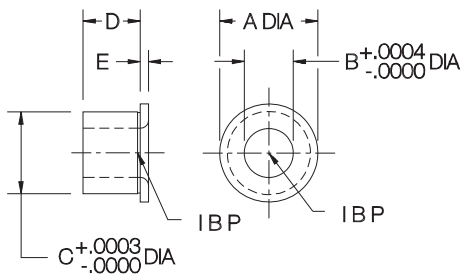
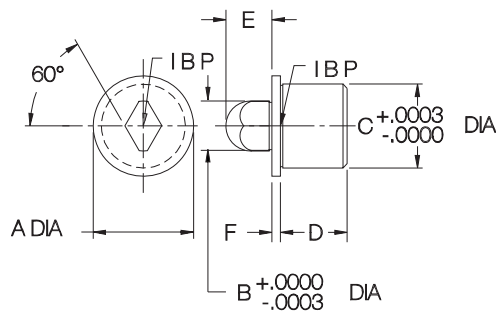
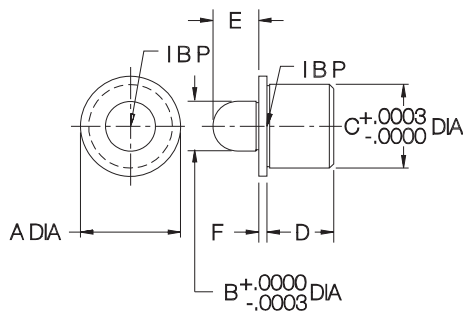
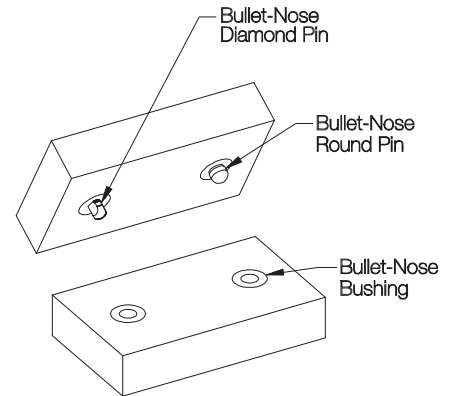

ROUND PINS (INCH)

PART NO.	A DIA	B HEAD DIA NOMINAL	B HEAD DIA ACTUAL	C SHANK DIA NOMINAL	C SHANK DIA ACTUAL	D	E	F
CL-8-BND	9/16	1/4	.2499	13/32	.4075	3/8	6	1/16
CL-9-BND	5/8	5/16	.3124	1/2	.5014		7	
CL-10-BND	3/4	3/8	.3748	5/8	.6265	1/2	9	10
CL-11-BND	7/8	1/2	.4998	3/4	.7515		10	
CL-12-BND	1-1/8	3/4	.7498	1	1.0015	3/4	9	10
CL-13-BND	1-1/2	1	.9998	1-3/8	1.3768		10	

ROUND PINS (METRIC)

PART NO.	A DIA	B DIA NOMINAL	B DIA ACTUAL	C DIA NOMINAL	C DIA ACTUAL	D	E	F
CLM-6-BRP	13mm	6mm	5.997	10mm	10.033	9mm	6mm	2mm
CLM-8-BRP	15mm	8mm	7.997	12mm	12.035		7mm	
CLM-10-BRP	18mm	10mm	9.995	15mm	15.038	11mm	9mm	10mm
CLM-12-BRP	22mm	12mm	11.995	18mm	18.038		10mm	

DIAMOND PINS (INCH)

PART NO.	A DIA	B DIA NOMINAL	B DIA ACTUAL	C DIA NOMINAL	C DIA ACTUAL	D	E	F
CL-8-BDP	9/16	1/4	.2499	13/32	.4075	3/8	7/32	1/16
CL-9-BDP	5/8	5/16	.3124	1/2	.5014		9/32	
CL-10-BDP	3/4	3/8	.3748	5/8	.6265	1/2	11/32	13/32
CL-11-BDP	7/8	1/2	.4998	3/4	.7515		13/32	
CL-12-BDP	1-1/8	3/4	.7498	1	1.0015	3/4	9/16	1/8
CL-13-BDP	1-1/2	1	.9998	1-3/8	1.3768		3/4	

DIAMOND PINS (METRIC)

PART NO.	A DIA	B DIA NOMINAL	B DIA ACTUAL	C DIA NOMINAL	C DIA ACTUAL	D	E	F
CLM-6-BDP	13mm	6mm	5.997	10mm	10.033	9mm	6mm	2mm
CLM-8-BDP	15mm	8mm	7.997	12mm	12.035		7mm	
CLM-10-BDP	18mm	10mm	9.995	15mm	15.038	11mm	9mm	10mm
CLM-12-BDP	22mm	12mm	11.995	18mm	18.038		10mm	

BUSHINGS (INCH)

PART NO.	A DIA	B DIA NOMINAL	B DIA ACTUAL	C DIA NOMINAL	C DIA ACTUAL	D	E
CLB-8000	9/16	6	.2501	13/32	.4075	7/16	1/16
CLB-9000	5/8	8	.3126	1/2	.5014		
CLB-10000	3/4	10	.3751	5/8	.6265	1/2	1/8
CLB-11000	7/8	12	.5001	3/4	.7515		
CLB-12000	1-1/8	10	.7502	1	1.0015	11/16	1/8
CLB-13000	1-1/2	12	1.0002	1-3/8	1.3768		

BUSHINGS (METRIC)

PART NO.	A DIA	B DIA NOMINAL	B DIA ACTUAL	C DIA NOMINAL	C DIA ACTUAL	D	E
CLM-6-B	13mm	6mm	6.002	10mm	10.033	8mm	2mm
CLM-8-B	15mm	8mm	8.002	12mm	12.035		
CLM-10-B	18mm	10mm	10.002	15mm	15.038	10mm	2mm
CLM-12-B	22mm	12mm	12.002	18mm	18.038		

BULLET-NOSE DOWELS

1144 STEEL, HEAT TREATED RC 50-62, BLACK OXIDE FINISH

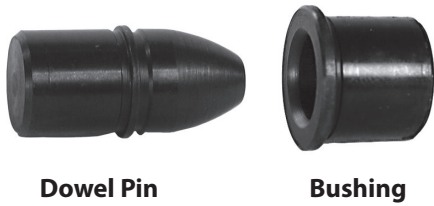

Dowel Pin

Bushing

Precision locating pin often used with a matching bushing to align two pieces of a fixture. The pin's head and shank diameters are concentric to within .0005 TIR. The bushing's ID and OD are concentric to within .0003 TIR.

DOWEL PINS (INCH)

PART NO.	A HEAD DIA NOMINAL	A HEAD DIA ACTUAL	B SHANK DIA NOMINAL	B SHANK DIA ACTUAL	C DIA	D	E	F	G DIA
CL-1-BND	1/4	.2499	1/4	.2510	.280	1/2	.12	.90	3mm
CL-2-BND	5/16	.3124	5/16	.3135	.344		.15	.94	4mm
CL-3-BND	3/8	.3749	3/8	.3760	.407		.18	1.03	5mm
CL-4-BND	1/2	.4999	1/2	.5010	.532		.18	1.09	6mm

DOWEL PINS (METRIC)

PART NO.	A HEAD DIA	A HEAD DIA ACTUAL	B SHANK DIA	B SHANK DIA ACTUAL	C DIA	D	E	F	G DIA
CLM-60-BND	6mm	5.997	6mm	6.025	7mm	12mm	3mm	22mm	3mm
CLM-80-BND	8mm	7.997	8mm	8.025	9mm		4mm	23mm	4mm
CLM-100-BND	10mm	9.997	10mm	10.025	11mm		5mm	25mm	5mm
CLM-120-BND	12mm	11.997	12mm	12.025	13mm		7mm	27mm	6mm

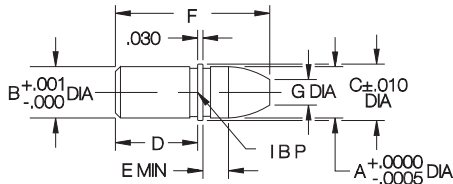

BUSHINGS (INCH)

PART NO.	A DIA NOMINAL	A DIA ACTUAL	B DIA	C SHANK DIA NOMINAL	C SHANK DIA ACTUAL	D	E
CLB-1000	1/4	.2501	.625	1/2	.5002	3/8	.100
CLB-2000	5/16	.3126	.750	5/8	.6253	1/2	
CLB-3000	3/8	.3751	.875	3/4	.7504	5/8	
CLB-4000	1/2	.5001					

BUSHINGS (METRIC)

PART NO.	A DIA	A DIA ACTUAL	B DIA	C SHANK DIA	C SHANK DIA ACTUAL	D	E
CLM-60-B	6mm	6.002	13mm	10mm	10.005	7	3
CLM-80-B	8mm	8.002	15mm	12mm	12.005	7	3
CLM-100-B	10mm	10.002	18mm	15mm	15.008	9	3
CLM-120-B	12mm	12.002	22mm	18mm	18.011	12	4

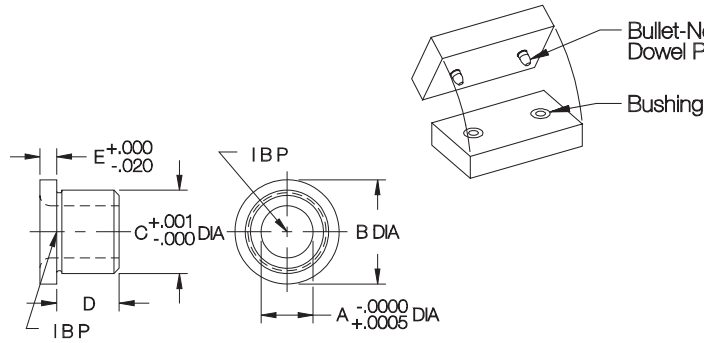

6

CONE LOCATOR PINS

1215 STEEL, CARBURIZED-HARDENED, BLACK OXIDE FINISH

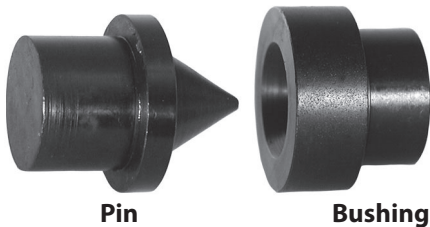

Pin

Bushing

Medium-accuracy tapered locating pin used with the mating bushing. These pins can be used for quick assembly of two fixture pieces, because they compensate for considerable misalignment. The pin's shank diameter and the bushing's OD are exactly the same size, to allow boring the installation hole in both fixture pieces at the same time for greater accuracy.

PIN (INCH)

PART NO.	A DIA	B DIA		C	D	E	F DIA
		NOMINAL	ACTUAL				
CL-5-CLP	3/4	1/2	.5014	3/16	3/8	5/16	.438
CL-7-CLP	1	3/4	.7515	3/16	9/16	1/2	.676

PIN (METRIC)

CLM-5-CLP	3/4	12mm	12.039	4.76	9.5	7.9	11.1
CLM-7-CLP	1	20mm	20.038	4.76	14.5	12.7	17.2

BUSHING (INCH)

PART NO.	A DIA	B DIA		C	D	E	GAP BETWEEN PIN & BUSHING HEAD WHEN ASSEMBLED
		NOMINAL	ACTUAL				
CL-5-CLB	3/4	1/2	.5014	1/4	1/4	.370	.050-.068
CL-7-CLB	1	3/4	.7515	3/8	3/8	.616	.043-.061

BUSHING (METRIC)

CLM-5-CLB	3/4	12mm	12.039	4.76	9.5	7.9	11.1
CLM-7-CLB	1	20mm	20.038	4.76	14.5	12.7	17.2

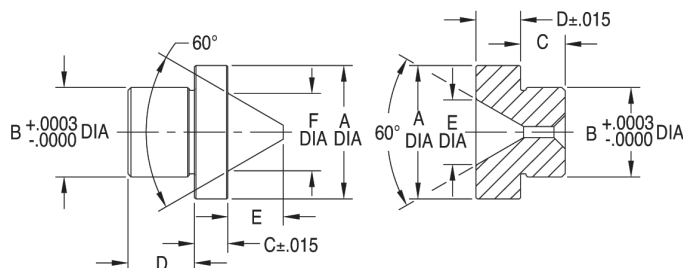

ON-SIZE® BUSHINGS

INVAR 36® NICKEL-IRON ALLOY

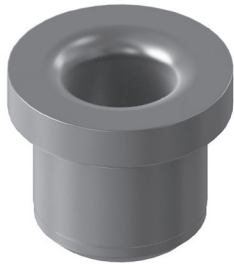

**ON-SIZE® Bushings
for Bullet-Nose Dowels
(Head Type)**

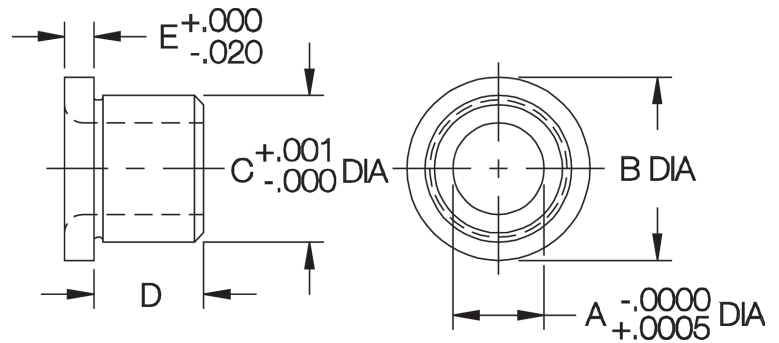

ON-SIZE® Bushings are made from Invar 36, a 36% nickel-iron alloy that has an extremely low coefficient of thermal expansion. Invar material is particularly useful in applications where minimum thermal expansion and high dimensional stability is required. Useful in high temperature applications up to 750°F (400°C), these products will maintain their size and accuracy even under heat-cool multiple cycles.

The precision bushings shown here are used with Bullet-Nose Dowels to align two pieces of a fixture. The bushing's ID and OD are concentric to within .0003" TIR. Available for pin diameters 1/4, 5/16, 3/8, and 1/2" (6, 8, 10, and 12mm in metric).

HEAD TYPE (INCH)

PART NO.	A DIA		B DIA	C DIA		D	E
	NOMINAL	ACTUAL		NOMINAL	ACTUAL		
CL-1000-BNV	1/4	.2501	.625	1/2	.5002	3/8	.100
CL-2000-BNV	5/16	.3126	.625	1/2	.5002	3/8	.100
CL-3000-BNV	3/8	.3751	.750	5/8	.6253	1/2	.100
CL-4000-BNV	1/2	.5001	.875	3/4	.7504	5/8	.100

HEAD TYPE (METRIC)

CLM-60-BNV	6mm	.2363	.512	10mm	.3939	.276	.118
CLM-80-BNV	8mm	.3151	.591	12mm	.4726	.276	.118
CLM-100-BNV	10mm	.3938	.709	15mm	.5909	.354	.118
CLM-120-BNV	12mm	.4725	.866	18mm	.7091	.472	.157

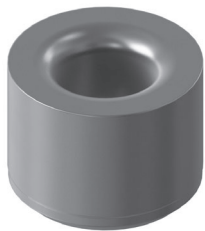

**ON-SIZE® Bushings
for Bullet-Nose Dowels
(Headless Type)**

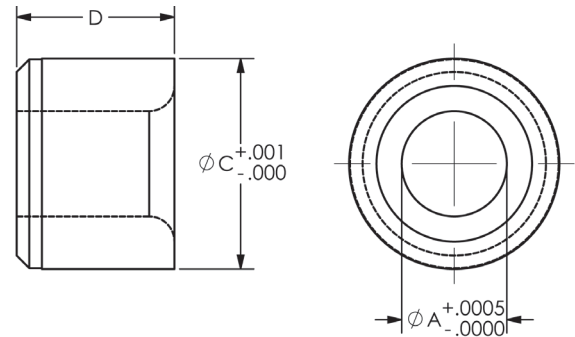

HEADLESS TYPE (INCH)

PART NO.	A DIA		C DIA		D
	NOMINAL	ACTUAL	NOMINAL	ACTUAL	
CL-1000-BPNV	1/4	.2501	1/2	.5002	3/8
CL-2000-BPNV	5/16	.3126	1/2	.5002	3/8
CL-3000-BPNV	3/8	.3751	5/8	.6253	1/2
CL-4000-BPNV	1/2	.5001	3/4	.7504	5/8

HEADLESS TYPE (METRIC)

CLM-60-BPNV	6mm	.2363	10mm	.3939	.276
CLM-80-BPNV	8mm	.3151	12mm	.4726	.276
CLM-100-BPNV	10mm	.3938	15mm	.5909	.354
CLM-120-BPNV	12mm	.4725	18mm	.7091	.472

CONSTRUCTION BALLS (SHOULDER TYPE)

STEEL: 1144 STEEL, HEAT TREATED RC 54-56

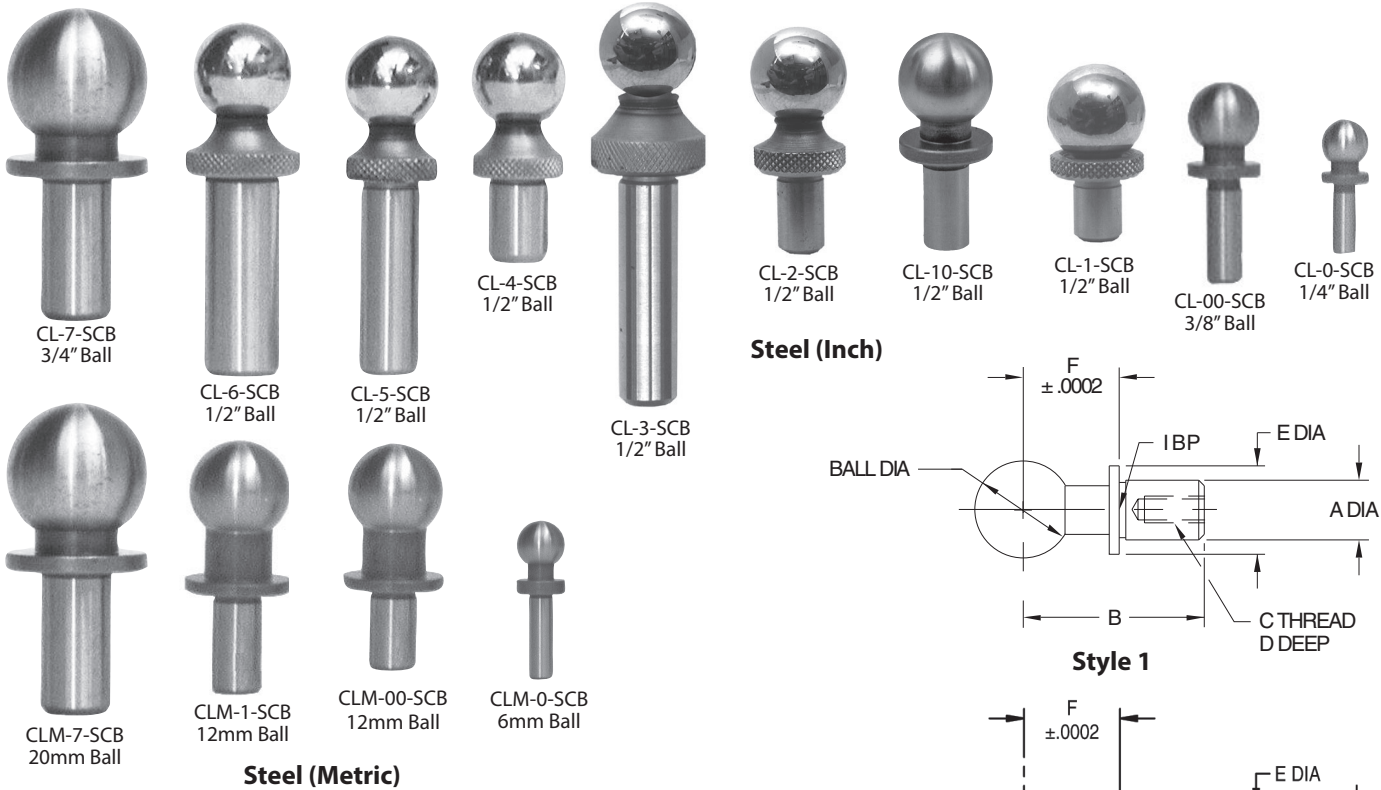

New 20mm ball diameter!

Precision tooling ball used as a reference point for critical inspection, layout, and machining operations. Shoulder type has a precision height-reference shoulder to locate the ball in three dimensions. Concentricity between ball and shank is .0002" TIR. Available with ball diameters from 1/4 to 3/4" (6 to 20mm in metric), in various shank diameters and lengths.

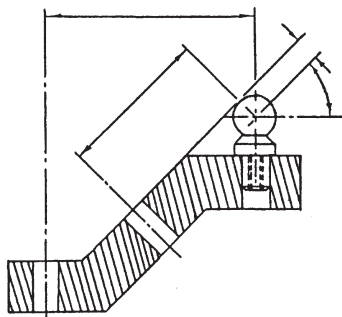

Shoulder-Type Construction Balls provide a reference point in three dimensions.

STEEL (INCH)

PART NO.	BALL DIA		A DIA		B	C	D	E DIA	F	STYLE
	NOMINAL	ACTUAL	NOMINAL	ACTUAL						
CL-0-SCB	1/4	.2502/.2498	1/8	.1250/.1246	.56	—	—	.25	.2000	1
CL-00-SCB	3/8	.3752/.3748	3/16	.1875/.1871	.75	—	—	.37	.3000	
CL-1-SCB	1/2	.5000/.4997	1/4	.2500/.2497	.63	#6-32	1/4	.46	.3125	2
CL-10-SCB				.2500/.2496	.94	—	—		.4000	
CL-2-SCB				.2500/.2497	.94	#6-32	5/16			
CL-3-SCB			5/16	.3125/.3122	1.50	—	—	.46	.5000	2
CL-4-SCB				.94	#6-32	5/16				
CL-5-SCB				1.50	—	—	.46	.5000		
CL-6-SCB	3/8	.3750/.3747	1.50	—	—	.56	.5000	1		
CL-7-SCB	3/4	.7502/.7498	3/8	.3750/.3746	1.25	—	—		.75	.5000

STEEL (METRIC)

PART NO.	BALL DIA		A DIA		B	C	D	E DIA	F	STYLE
	NOMINAL	ACTUAL	NOMINAL	ACTUAL						
CLM-0-SCB	6mm	.2364/.2360	3mm	.1181/.1177	.47	—	—	.24	.2362 (6mm)	1
CLM-00-SCB	12mm	.4726/.4722	6mm	.2362/.2358	.87	—	—	.47	.4724 (12mm)	
CLM-1-SCB					.98	M3.5	.24			
CLM-7-SCB	20mm	.7876/.7872	10mm	.3937/.3983	1.50	M6	.38	.79	.7874 (20mm)	

CONSTRUCTION BALLS (SHOULDER TYPE)

STAINLESS STEEL: 440C STAINLESS STEEL, HEAT TREATED RC 57-59



CL-2-SCB
1/2" Ball



CL-1-SCB
1/2" Ball



CL-0-SCB
1/4" Ball

Stainless Steel (Inch)



CLM-1-SCB
12mm Ball



CLM-00-SCB
12mm Ball

Stainless Steel (Metric)

Also available in stainless steel!

Precision tooling ball used as a reference point for critical inspection, layout, and machining operations. Shoulder type has a precision height-reference shoulder to locate the ball in three dimensions. Concentricity between ball and shank is .0002" TIR. Stainless steel version is available with ball diameters from 1/4 to 1/2" (12mm in metric).

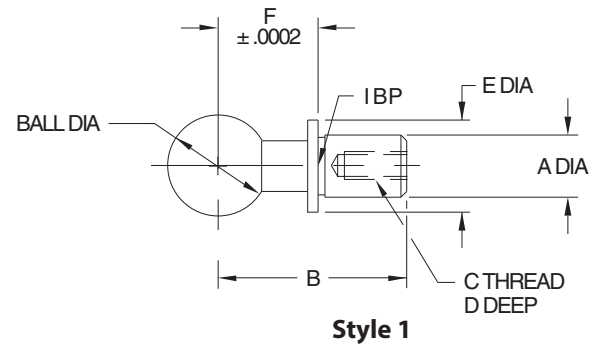

Style 1

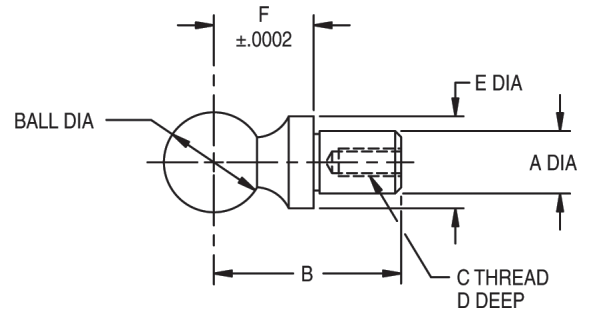

Style 2

STAINLESS STEEL (INCH)

PART NO.	BALL DIA		A DIA		B	C	D	E DIA	F	STYLE
	NOMINAL	ACTUAL	NOMINAL	ACTUAL						
CL-0-SCB-S	1/4	.2502/.2498	1/8	.1250/.1246	.56	—	—	.25	.2000	1
CL-1-SCB-S	1/2	.5000/.4997	1/4	.2500/.2497	.63	#6-32	1/4	.46	.3125	2
CL-2-SCB-S		.5000/.4997			.94	#6-32	5/16		.5000	

STAINLESS STEEL (METRIC)

PART NO.	BALL DIA		A DIA		B	C	D	E DIA	F	STYLE
	NOMINAL	ACTUAL	NOMINAL	ACTUAL						
CLM-00-SCB-S	12mm	.4726/.4722	6mm	.2362/.2358	.87	—	—	.47	.4724 (12mm)	1
CLM-1-SCB-S					.98	M3.5	.24			

CONSTRUCTION BALLS (ADJUSTABLE TYPE)

1144 STEEL, HEAT TREATED RC 54-56



CL-5-CB
1/2" Ball



CL-3-CB
1/2" Ball



CL-1-CB
1/2" Ball



CL-00-CB
3/8" Ball



CL-0-CB
1/4" Ball

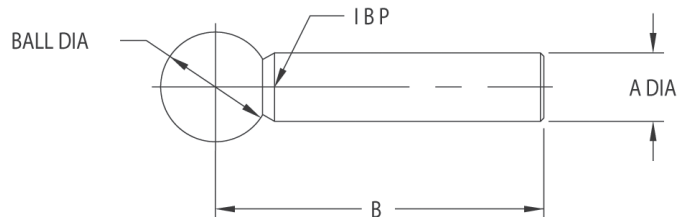

Precision tooling ball used as a reference point for critical inspection, layout, and machining operations. Adjustable type has no shoulder, so it can be set at any desired height then locked with a set screw. Concentricity between ball and shank is .0002" TIR. Available with ball diameters from 1/4 to 1/2", in various shank diameters and lengths.

STEEL (INCH)

PART NO.	BALL DIA		A DIA		B
	NOMINAL	ACTUAL	NOMINAL	ACTUAL	
CL-0-CB	1/4	.2502/.2498	1/8	.1250/.1246	.56
CL-00-CB	3/8	.3752/.3748	3/16	.1875/.1871	
CL-1-CB	1/2	.5000/.4997	1/4	.2500/.2497	1.50
CL-3-CB			5/16	.3125/.3122	
CL-5-CB			3/8	.3750/.3747	

CONSTRUCTION-BALL COVERS

ZINC DIE CASTING



Sturdy cover that protects a Construction Ball from damage after installation.

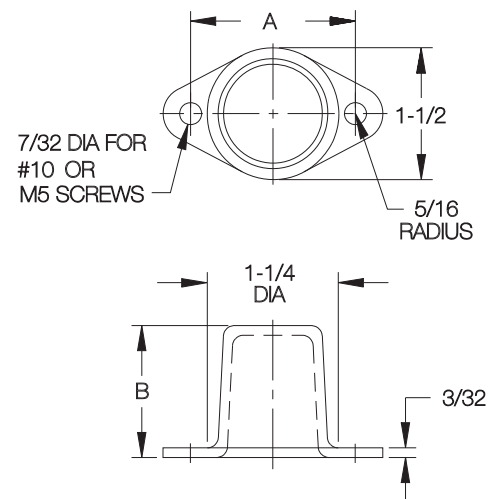
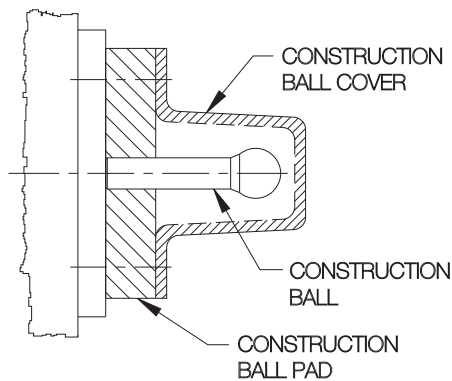

PART NO.	A	B
CL-2-COVER	1-7/8	1-1/2

CONSTRUCTION-BALL PADS

ROUND (STEEL): 1144 STEEL, BLACK OXIDE FINISH. ROUND (STAINLESS STEEL): 17-4PH STAINLESS STEEL, PASSIVATED.
 SHANK TYPE: 8620 STEEL. CARBURIZED-HARDENED, BLACK OXIDE FINISH

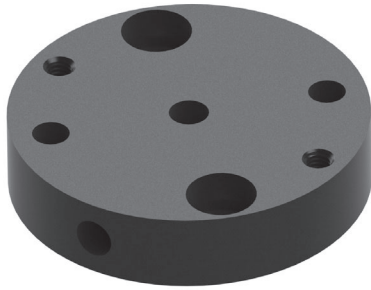

Round

Now also available in stainless steel!

Round Construction-Ball Pads should be fastened with two socket-head cap screws, then can be doweled in place to maintain accurate location. The Construction Ball can be secured by installing a #10-32 set screw (not furnished) in the crosshole.

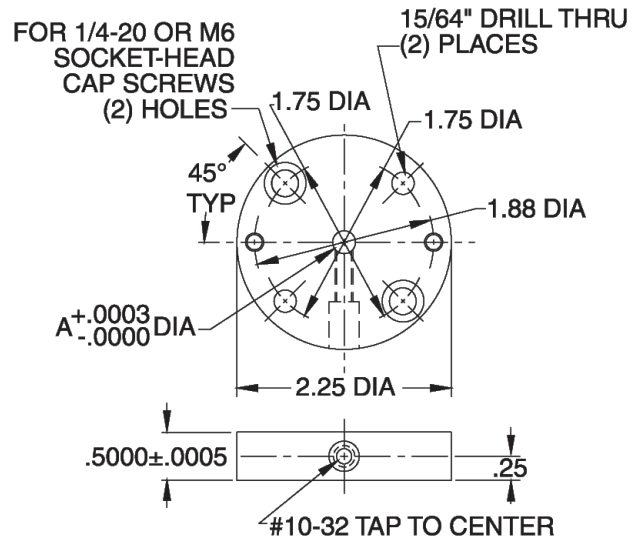

ROUND – STEEL (INCH)

PART NO.	A DIA	
	NOMINAL	ACTUAL
CL-1-CBPR	1/4	.2500

ROUND – STAINLESS STEEL (INCH)

CL-1-CBPR-S	1/4	.2500
-------------	-----	-------

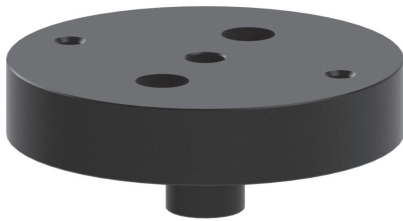

Shank Type

Shank-type Construction-Ball Pads should be installed in a reamed hole for accurate location, then fastened with two socket-head cap screws.

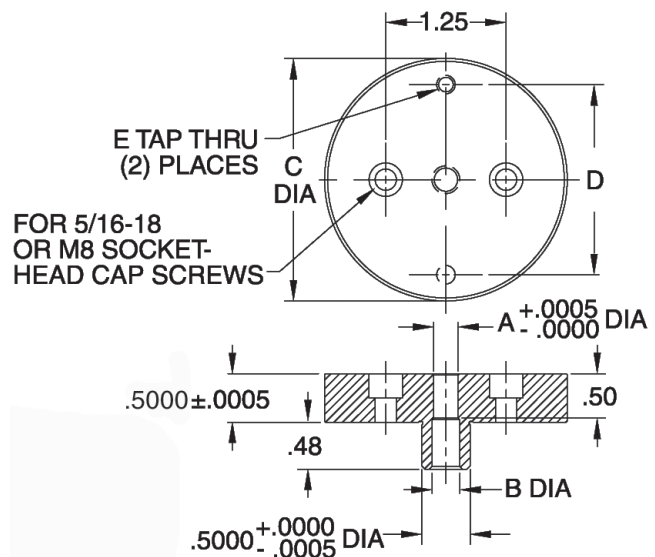

SHANK TYPE – STEEL (INCH)

PART NO.	A DIA		B DIA	C DIA	D	E
	NOMINAL	ACTUAL				
CL-1-CBPK	1/4	.2500	.257	2.50	1.88	#10-24

REVERSIBLE CONSTRUCTION BALL PAD

STEEL: 1144 STEEL, BLACK OXIDE
 STAINLESS STEEL: 17-4PH STAINLESS STEEL, PASSIVATED

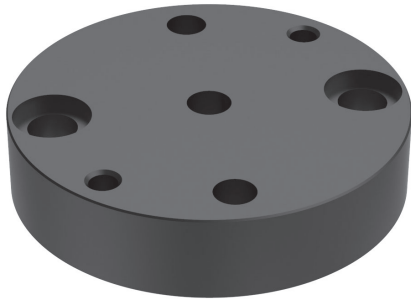

INCH

Reversible round pad for mounting a Construction Ball. This precision reversible round pad can be flipped over in order to mirror a fixture (see application). These round pads should be fastened with two ultra-low-profile socket-head cap screws, then doweled in place to maintain accurate location. The Construction Ball can be secured by installing a #10-32 setscrew (not furnished) in the crosshole. Available in steel and stainless steel. Made in USA.

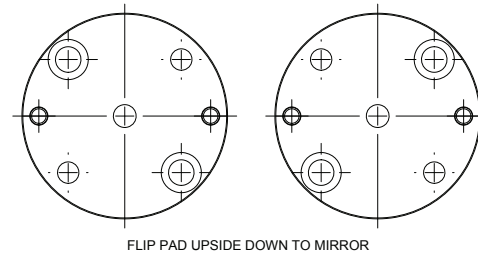
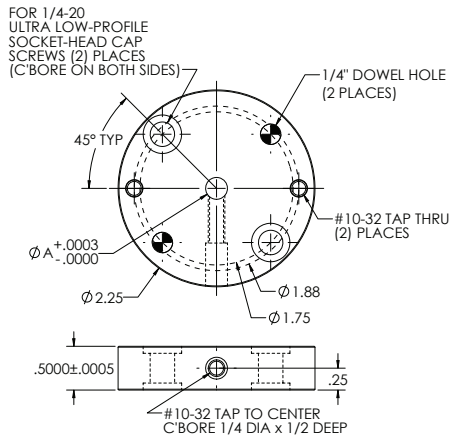

METRIC

Reversible round pad for mounting a Construction Ball. This precision reversible round pad can be flipped over in order to mirror a fixture (see application). These round pads should be fastened with two ultra-low-profile socket-head cap screws, then doweled in place to maintain accurate location. The Construction Ball can be secured by installing a m5 setscrew (not furnished) in the crosshole. Available in steel and stainless steel. Made in USA.

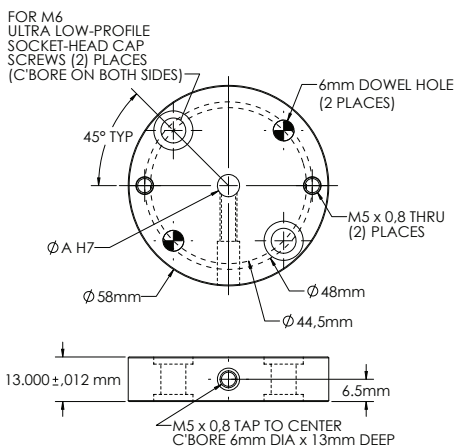

STEEL

PART NO.	A DIA NOMINAL	A DIA ACTUAL
CL-1-R-CBPR	1/4	.2500
CL-2-R-CBPR	5/16	.3125
CL-3-R-CBPR	3/8	.3750

STAINLESS STEEL

CL-1-R-CBPR-S	1/4	.2500
CL-2-R-CBPR-S	5/16	.3125
CL-3-R-CBPR-S	3/8	.3750

STEEL

PART NO.	A DIA NOMINAL	A DIA ACTUAL
CLM-3-R-CBPR	3mm	3,010 / 3,000
CLM-6-R-CBPR	6mm	6,012 / 6,000
CLM-10-R-CBPR	10mm	10,015 / 10,000

STAINLESS STEEL

CLM-3-R-CBPR-S	3mm	3,010 / 3,000
CLM-6-R-CBPR-S	6mm	6,012 / 6,000
CLM-10-R-CBPR-S	10mm	10,015 / 10,000

FIXTURE KEYS

1018 STEEL, CARBURIZED-HARDENED, BLACK OXIDE FINISH

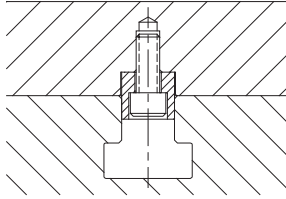
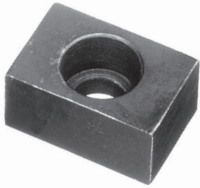

Standard key for fixtures slotted to mount on one specific machine table. Depth of slot in fixture should be 1/2 of B dimension.

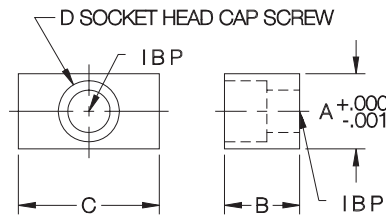

INCH

PART NO.	TABLE SLOT SIZE	A	B	C	D
CL-1-FK	1/2	.5000	1/2	3/4	1/4-20
CL-3-FK	5/8	.6250		3/4	5/16-18
CL-4-FK	11/16	.6875		1	
CL-5-FK	3/4	.7500		1-1/4	
CL-6-FK	13/16	.8125			

METRIC

CLM-12-FK	12mm	12	10	8	20	M5
CLM-14-FK	14mm	14		22	M6	
CLM-16-FK	16mm	16				
CLM-18-FK	18mm	18				
CLM-20-FK	20mm	20				

6

STEP FIXTURE KEYS

MILD STEEL, CARBURIZED-HARDENED, BLACK OXIDE FINISH

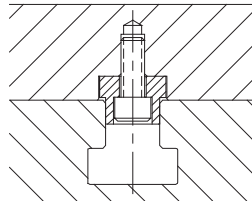
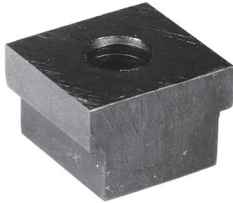

Adapts a key-slotted fixture or vise to machine tables with a different slot size. Available for inch or metric slots. Top and bottom of key are centered within .0005 of each other.

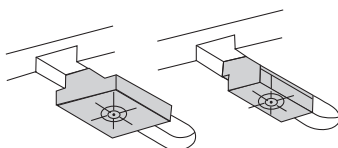

Step Fixture Keys are available for machine-table slots either larger or smaller than a given fixture slot. (Viewed from underside of fixture.)

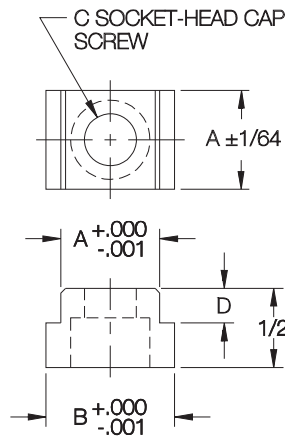

INCH FIXTURE SLOTS

PART NO.	FIXTURE SLOT SIZE	A	TABLE SLOT SIZE	B	C SOCKET-HEAD CAP SCREW (ORDER SEPARATELY)	D
CL-10-SFK-18	5/8	.6250	18mm	.7087	CL-5/16-18X.75-SHCS	7/32
CL-11-SFK-625	11/16	.6875	5/8	.6250	CL-5/16-18X.75-SHCS	9/32
CL-11-SFK-16			16mm	.6299		9/32
CL-11-SFK-18			18mm	.7087		7/32
CL-11-SFK-20			20mm	.7874		
CL-12-SFK-625	3/4	.7500	5/8	.6250	CL-5/16-18X.75-SHCS	9/32
CL-12-SFK-18			18mm	.7087	9/32	
CL-13-SFK-18	13/16	.8125	18mm	.7087	CL-5/16-18X.75-SHCS	9/32

METRIC FIXTURE SLOTS

PART NO.	FIXTURE SLOT SIZE	A	TABLE SLOT SIZE	B	C SOCKET-HEAD CAP SCREW (ORDER SEPARATELY)	D
CL-20-SFK-18	20mm	20	18mm	181	CLM-6X15-SHCS	7

SURE-LOCK™ FIXTURE KEYS

1215 STEEL, CARBURIZED-HARDENED, BLACK OXIDE FINISH

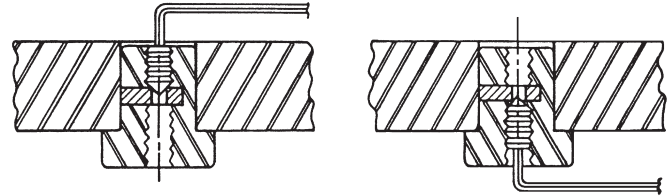

Lock in place from above or below using a hex wrench.

Perfect fixture key for most applications. Keys are interchangeable because they all fit in a 5/8 reamed hole. Allows mounting any fixture on any machine simply by switching keys. Eliminates the need to slot fixtures. Concentricity .0005 TIR or better. Available for inch or metric machine-table slots.

INCH

PART NO.	TABLE SLOT SIZE	A	B	C	D
CL-375-SLFK	3/8	.3750	1/2	3/8	.23
CL-437-SLFK	7/16	.4375			
CL-500-SLFK	1/2	.5000	3/4	7/16	.41
CL-5000-SLFK			1/2	3/8	.23
CL-562-SLFK	9/16	.5625	3/4	7/16	.41
CL-5625-SLFK			1/2	3/8	.23
CL-625-SLFK	5/8	.6250	3/4	7/16	.41
CL-6250-SLFK			1/2	3/8	.23
CL-687-SLFK	11/16	.6875	3/4	7/16	.41
CL-6875-SLFK			1/2	3/8	.23
CL-7500-SLFK	3/4	.7500	3/4	7/16	.41
CL-8125-SLFK	13/16	.8125			

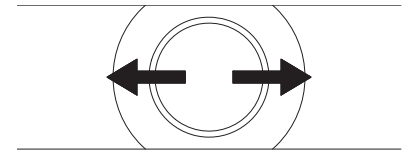

Patented locking action aligns fixture key perfectly with slot axis.

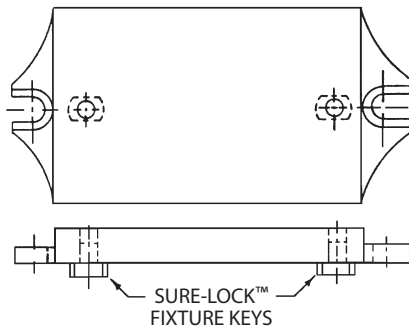

METRIC

PART NO.	TABLE SLOT SIZE	A (mm)	SHANK DIA	B (mm)	C (mm)	D (mm)
CL-12-SLFK	12mm	12	5/8"	12.5	9.5	9
CL-14-SLFK	14mm	14	5/8"	19	11	10.5
CL-16-SLFK	16mm	16	5/8"	19	11	10.5
CL-18-SLFK	18mm	18	5/8"	19	11	10.5
CL-20-SLFK	20mm	20	5/8"	19	11	10.5
CL-22-SLFK	22mm	22	5/8"	19	11	10.5

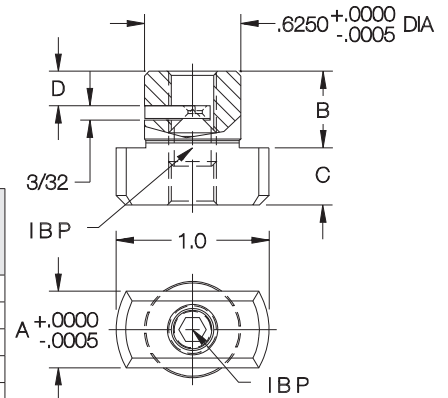

REAMED-HOLE FIXTURE KEYS

1215 STEEL, CARBURIZED-HARDENED, BLACK OXIDE FINISH

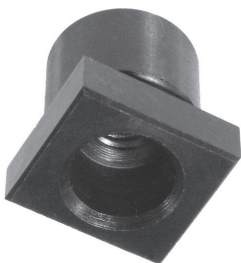

Each key fits two different table slots by turning 90°. Install in a 5/8 reamed hole. Fasten from above with a 5/16-18 Socket-Head Cap Screw, or from below with a 1/4-20 Socket-Head Cap Screw. Concentricity .0005 or better.

INCH

PART NO.	TABLE SLOT SIZES	A	B
CL-1-RFK	5/8 and 11/16	.6875	
CL-2-RFK	5/8 and 3/4	.6250	.7500
CL-3-RFK	5/8 and 13/16		.8125
CL-4-RFK	11/16 and 3/4	.6875	.7500
CL-6-RFK	3/4 and 13/16	.7500	.8125

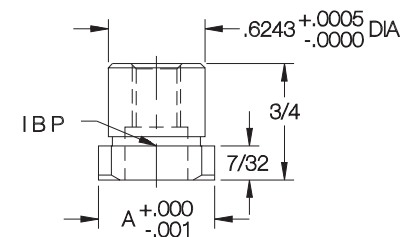
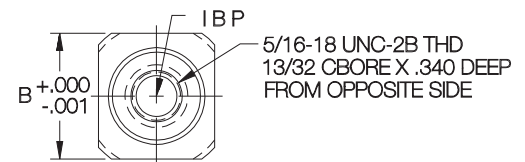

LOCATING KEYS

1144 OR 1045 STEEL, HEAT TREATED, BLACK OXIDE FINISH

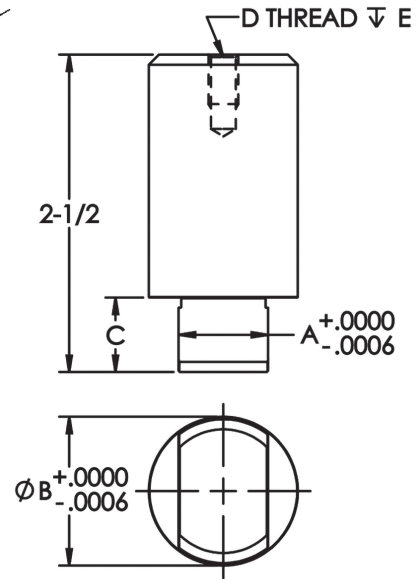
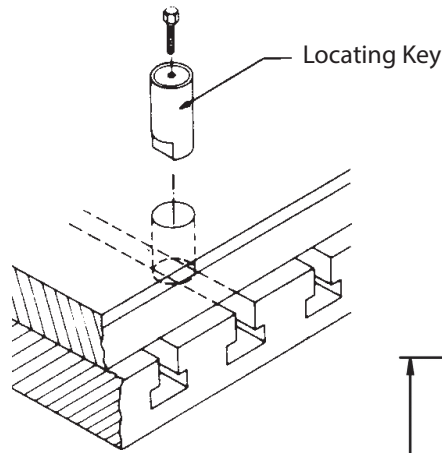

These heavy-duty removable-type keys are our standard fixture keys for large fixture plates. Locating keys are available in two body diameters — metric (30mm) and inch (1-1/8"). These keys can be used for mounting all of our Rectangular Tooling Plates, blank and modular. Locating Keys can be inserted from above after placing the fixture plate on the machine table, to keep the top free of obstructions. If desired, Locating Keys can be removed before machining, after the fixture is fastened to the machine table. The tapped hole in the key's top surface makes insertion and removal easier. Locating flats are accurate to within .0005" true position of the body diameter.

METRIC DIAMETER (30mm)

PART NO.	TABLE SLOT SIZE	A (mm)	B DIA (mm)	C (mm)	D THREAD	THREAD PITCH (mm)	E (mm)
CLM-14-LK	14mm	14	30	15	M6	1	10
CLM-6250-LK	5/8"	15.88					
CLM-18-LK	18mm	18					
CLM-8125-LK	13/16"	20.64					
CLM-22-LK	22mm	22					
CLM-8750-LK	7/8"	22.23					

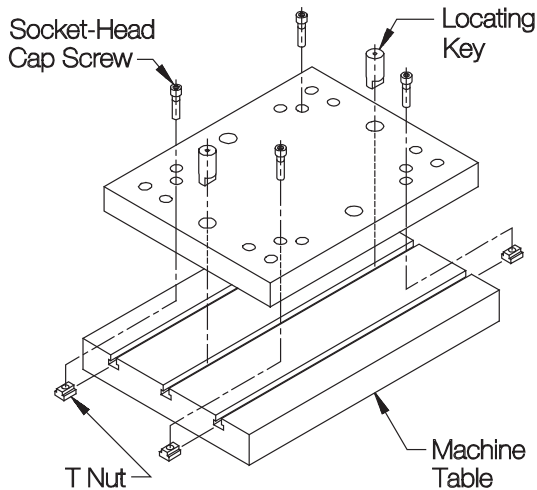

INCH DIAMETER (1-3/16")

PART NO.	TABLE SLOT SIZE	A	B DIA	C	D THREAD	E
CL-MF10-4401	14mm	.5512	1.1875	5/8	1/4-20	3/8
CL-MF10-4406	9/16	.5625				
CL-MF10-4407	5/8	.6250				
CL-MF10-4402	16mm	.6299				
CL-MF10-4408	11/16	.6875				
CL-MF10-4403	18mm	.7087				
CL-MF10-4409	3/4	.7500				
CL-MF10-4404	20mm	.7874				
CL-MF10-4411	13/16	.8125				
CL-MF10-4405	22mm	.8661				
CL-MF10-4410	7/8	.8750				

PALLET FIXTURE KEYS

1215 STEEL, CARBURIZED-HARDENED, BLACK OXIDE FINISH



Center Pin



Radial Pin

Fixture keys for mounting tooling plates and blocks on standard DIN pallets. Each pallet requires one Center Pin and one Radial Pin (for orientation). The Radial Pin is usually removed after fastening the pallet to the machine table.

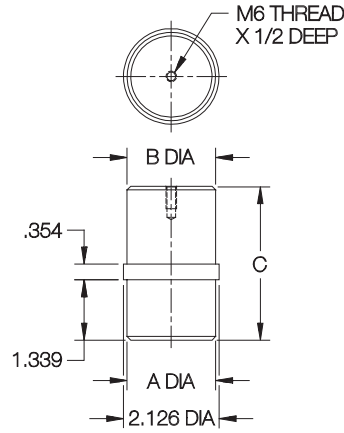

Center Pin

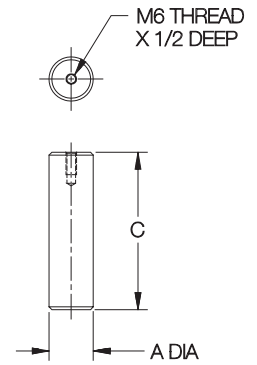

Radial Pin

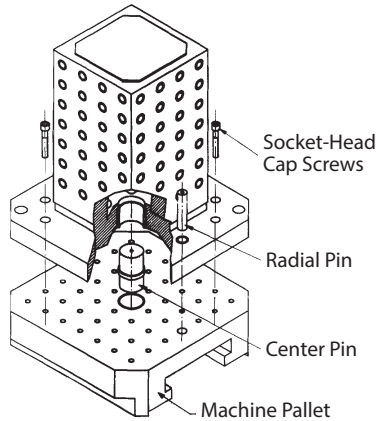

CENTER PINS

PART NO.	A DIA		B DIA		C
	NOMINAL	ACTUAL	NOMINAL	ACTUAL	
CLM-25-PFKC			25mm	.9839/.9835	2.87
CLM-30-PFKC	50mm	1.9681/1.9676	30mm	1.1808/1.1804	3.42
CLM-50-PFKC			50mm	1.9681/1.9676	

RADIAL PINS

PART NO.	A DIA		C
	NOMINAL	ACTUAL	
CLM-20-PFKR	20mm	.7871/.7867	3.50
CLM-25-PFKR	25mm	.9839/.9835	4.92

6

MILL FIXTURE KEYS

1215 STEEL, CARBURIZED-HARDENED, BLACK OXIDE FINISH



Can be removed from above after mounting fixture on machine. Fits either 11/16 or 13/16 table slots by turning 90°. Install in a 7/8 reamed hole. Concentricity .0005 or better.

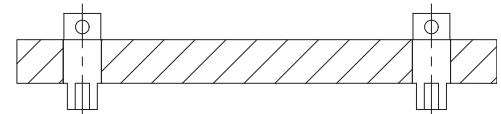
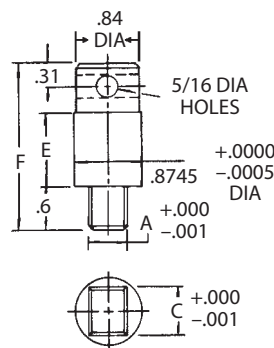

INCH

PART NO.	TABLE SLOT SIZES	A			
		A	C	E	F
CL-1-MFK-1	11/16 or 13/16	.6873	.8123	1.00	2.20
CL-1-MFK-2				3.20	4.40

CLAMPS AND ACCESSORIES



Clamp Straps



Edge Clamps



Swing Clamps



Internal Clamps



Nuts



Washers



Studs, Bolts, & T Nuts



Cams



Clamp Rests & Accessories

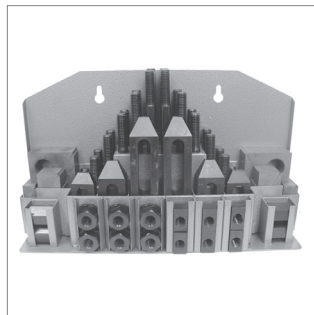

Clamping Kits



Portable Clamps



Hammers & Hand Tools

Also see:



Toggle Clamps
p. 438-505



Hydraulic Power Workholding
p. 613-623

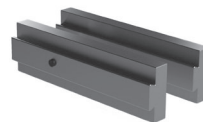

CARVESMART™ Dovetailed Quick-Change Vise Jaw System
SEE WEBSITE



Precision Vises
p. 644-652

CLAMP STRAPS

TYPES



SLOTTED-HEEL CLAMP STRAPS

Popular Clamp Strap with a slot underneath to allow sliding it straight back for clear unloading. Two drill spots on the sides provide a secure grip for retracting the clamp. Available in steel or stainless steel with several strap lengths available for each size.



SLOTTED-HEEL GOOSENECK CLAMP STRAPS

Gooseneck version of our Slotted-Heel Clamp Straps. This design recesses the clamping nut to provide a low overall profile. An indentation at the rear of each side provides a secure finger grip for retracting the clamp. Also available as a complete assembly.

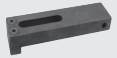

SLOTTED-HEEL PADDED CLAMP STRAPS

Slotted-Heel Clamp Strap that features a replaceable clamping pad attached with two screws (furnished). Clamp Strap also easily accepts custom pads or other attachments. Read end is tapped on either side for a Finger Pin.



TAPPED-HEEL CLAMP STRAPS

Popular Clamp Strap with a tapped heel that accepts a clamping screw or rear support. Often used with a Guide Block to allow sliding the strap straight back for clear loading. Two drill spots on the sides provide a secure grip for retracting the clamp. Can also be used with a Stud Leveling Foot as a rear support.

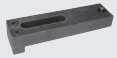

TAPPED-HEEL PADDED CLAMP STRAPS

Tapped-Heel Clamp Strap that features a replaceable clamping pad attached with two screws (furnished). Clamp Strap also easily accepts custom pads or other attachments. Replacement pads and assemblies also available.



FORGED CLAMP STRAPS (TAPPED HEEL)

High-strength Tapped-Heel Clamp Strap available in straight or gooseneck design, with a locator nose or plain nose. Locator-nose version is ideal for workpieces with machined ends. The accurately machined notch ensures precise, repeatable clamp location for increased machining clearance.



TAPERED-NOSE CLAMP STRAPS (TAPPED HEEL)

Mini-size Tapped-Heel Clamp Strap with a tapered nose for clamping in tight spaces. Available in stainless steel. Also available as a complete assembly, where a Fixture Stud has a thread-locking interference thread at the bottom end to install permanently in a fixture plate.



WIDE-NOSE CLAMP STRAPS (TAPPED HEEL)

Mini-size Tapped-Heel Clamp Strap with an extra-wide nose. Available in stainless steel. Also available as a complete assembly, where a Fixture Stud has a thread-locking interference thread at the bottom end to install permanently in a fixture plate.



FORGED ADJUSTABLE CLAMPS

Rugged forged steel pivot clamp. Instant height adjustment without blocks or shims. One-piece assembly allows quick setups and eliminates lost clamp pieces. Clamp can swing 90° in either direction for loading clearance.

CONTINUED ON NEXT PAGE

CLAMP STRAPS

TYPES



DOUBLE-END CLAMP STRAPS

Clamp Strap with two clamping ends, for holding two workpieces simultaneously. A complete Clamp-Strap Assembly is available as well. Order pieces individually. See product page for details. Also available in metric.



DOUBLE-END GOOSENECK CLAMP STRAPS

Gooseneck version of our Double-End Clamp Straps. This design recesses the clamping nut to provide a low overall profile. Double-End Clamps have two clamping ends, for holding two workpieces simultaneously. Turn strap 90° for clear loading.



PLAIN CLAMPS

Plain Clamps are double-end, tapered-nose clamp straps that can be used for holding two workpieces simultaneously, or used with Step Blocks as a rear support for holding a single workpiece.



FORGED U CLAMPS

Open U end allows totally removing clamp strap when unclamped. Clamp tips are stepped to provide repeatable location. Cylindrical pin end minimizes contact area and is useful for clamping in horizontal holes.

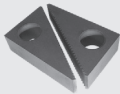

STEP BLOCKS & CLAMPS

Serrated Blocks can be used individually or in pairs, as a clamp rest. Use a single block with Step Clamps, or a pair of blocks with Plain Clamps. All blocks and clamps are made from top-grade steel.

7

CLAMPING FORCE OF STANDARD CLAMP STRAPS

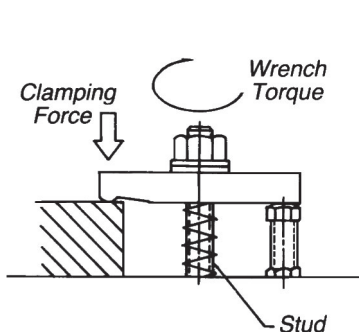

INCH

Stud Size	Recommended Torque* (ft-lbs)	Clamping Force (lbs)	Tensile Force in Stud (lbs)
#10-32	2	300	600
1/4-20	4	500	1000
5/16-18	9	900	1800
3/8-16	16	1300	2600
1/2-13	38	2300	4600
5/8-11	77	3700	7400
3/4-10	138	5500	11000
7/8-9	222	7600	15200
1"-8	333	10000	20000

METRIC

Stud Size	Recommended Torque* (ft-lbs)	Clamping Force (lbs)	Tensile Force in Stud (lbs)
M6	4	500	1000
M8	9	900	1800
M10	20	1500	3000
M12	35	2200	4400
M16	84	4000	8000
M20	165	6300	12600
M24	283	9000	18000

*Clean, dry clamping stud torqued to approximately 33% of its 100,000 psi yield strength (2:1 lever ratio).

FORGED ADJUSTABLE CLAMPS

FORGED 1045 STEEL, BLACK OXIDE FINISH



Rugged forged steel pivot clamp. Instant height adjustment without blocks or shims. One-piece assembly allows quick setups and eliminates lost clamp pieces. Removable brass heel protects machine table. Clamp can swing 90° in either direction for loading clearance.

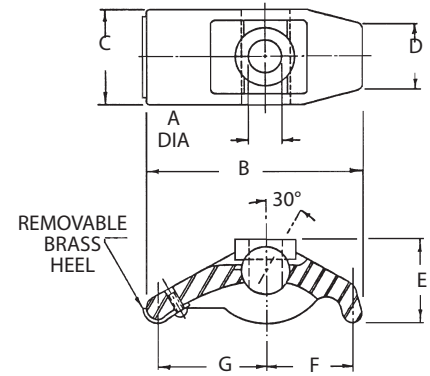
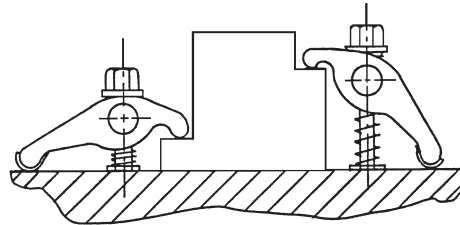

CLAMP STRAPS

PART NO.	STUD SIZE	CLAMPING RANGE	A DIA	B	C	D	E	F	G
CL-6-FAC	5/16, 3/8, M8, or M10	0 to 1-3/4	7/16	3-1/4	1-1/4	7/8	1	1-1/8	1-7/8
CL-8-FAC	1/2 or M12	0 to 2-1/16	9/16	4	1-5/8	1-1/8	1-7/16	1-7/16	2-5/16
CL-10-FAC	5/8 or M16	0 to 3	11/16	5-1/2	1-7/8	1-3/8	1-7/8	2	3-1/4
CL-12-FAC	3/4 or M20	0 to 4-1/4	13/16	6-1/4	2-5/8	2	2-1/4	2-1/8	3-1/2
CL-16-FAC	7/8, 1, or M24	0 to 5-1/2	1-1/16	7	3-1/8	2-3/8	2-7/16	2-1/4	4



Assembly with Flange Nut
CL-x-FACA-FN

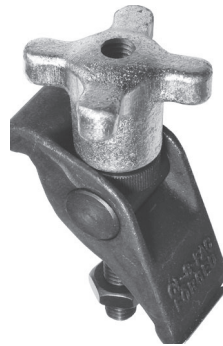

Assembly with Hand Knob
CL-x-FACA-HK

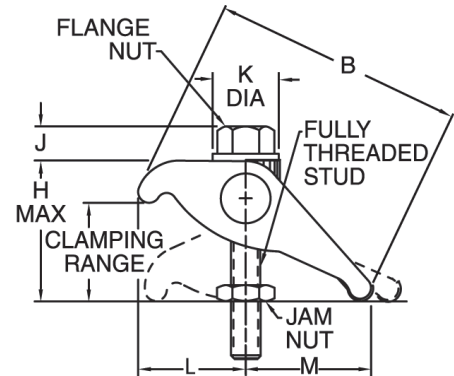
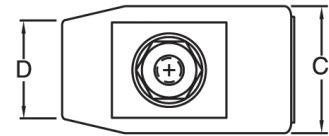

ASSEMBLIES (INCH)

PART NO.	STUD SIZE	CLAMPING RANGE	H	J	K DIA	L		M		FORGED ADJUSTABLE CLAMP	FULLY THREADED STUD	JAM NUT	FLANGE NUT
						MIN	MAX	MIN	MAX				
CL-5-FACA-FN	5/16-18	0 to 1-3/4	2-1/8	3/8	3/4	1-1/16	1-1/4	1-3/4	2	CL-6-FAC	CL-5/16-18x3.00-FTS	CL-5-JN	CL-9-FN
CL-6-FACA-FN	3/8-16			1/2	7/8								
CL-8-FACA-FN	1/2-13	0 to 2-1/16	2-5/8	11/16	1-1/8	1-3/8	1-9/16	2-1/8	2-7/16	CL-8-FAC	CL-1/2-13x4.00-FTS	CL-8-JN	CL-3-FN
CL-10-FACA-FN	5/8-11	0 to 3	3-3/4	13/16	1-3/8	1-13/16	2-1/8	2-15/16	3-3/8	CL-10-FAC	CL-5/8-11x5.00-FTS	CL-10-JN	CL-4-FN
CL-12-FACA-FN	3/4-10	0 to 4-1/4	5-3/8	1	1-5/8	2-1/8	2-7/16	3-5/16	3-13/16	CL-12-FAC	CL-3/4-10x7.00-FTS	CL-12-JN	CL-5-FN
CL-14-FACA-FN	7/8-9	0 to 5-1/2	7	1-1/8	1-3/4	2-1/4	2-5/8	3-13/16	4-3/8	CL-16-FAC	CL-7/8-9x8.00-FTS	CL-14-JN	CL-6-FN
CL-16-FACA-FN	1"-8			1-1/4	2								

ASSEMBLIES (METRIC)

CLM-5-FACA-FN	M8	0 to 1-3/4	2-1/8	.39	.75	1-1/16	1-1/4	1-3/4	2	CL-6-FAC	CLM-8x80-FTS	CLM-8-JN	CLM-8-FN
CLM-6-FACA-FN	M10			.51	.87								
CLM-8-FACA-FN	M12	0 to 2-1/16	2-5/8	.67	1.10	1-3/8	1-9/16	2-1/8	2-7/16	CL-8-FAC	CLM-12x110-FTS	CLM-12-JN	CLM-12-FN
CLM-10-FACA-FN	M16	0 to 3	3-3/4	.83	1.34	1-13/16	2-1/8	2-15/16	3-3/8	CL-10-FAC	CLM-16x125-FTS	CLM-16-JN	CLM-16-FN
CLM-12-FACA-FN	M20	0 to 4-1/4	5-3/8	.98	1.61	2-1/8	2-7/16	3-5/16	3-13/16	CL-12-FAC	CLM-20x175-FTS	CLM-20-JN	CLM-20-FN
CLM-16-FACA-FN	M24	0 to 5-1/2	7	1.26	2.01	2-1/4	2-5/8	3-13/16	4-3/8	CL-16-FAC	CLM-24x200-FTS	CLM-24-JN	CLM-24-FN

SLOTTED-HEEL CLAMP STRAPS

STEEL: 1018, CARBURIZED-HARDENED, BLACK OXIDE FINISH
 STAINLESS STEEL: 300 SERIES



**Steel and
Stainless Steel**

Popular Clamp Strap with a slot underneath to allow sliding it straight back for clear loading. Two drill spots on the sides provide a secure grip for retracting the clamp. Available in steel for 1/4-20 (M6) to 3/4-10 (M20) stud sizes, or stainless steel for #10-32 to 3/8-16 stud sizes. Each size is available in several strap lengths.

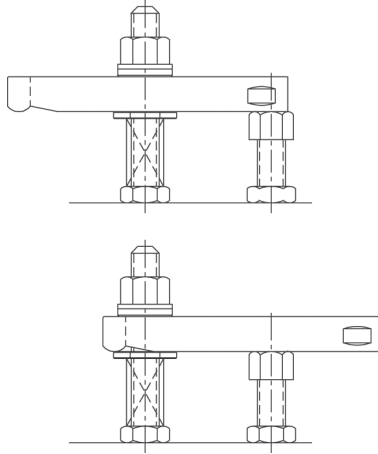

INFO+: See page 263 for complete assemblies using these Clamp Straps.

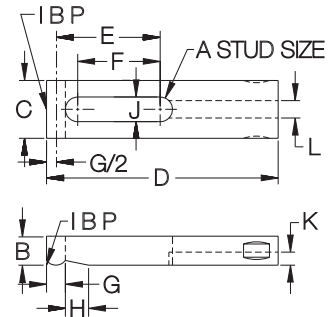

STRAPS — STEEL

PART NO.	A	B	C	D	E	F	G	H	J	K	L
CL-0-CS	1/4-20 or M6	3/8	5/8	2	27/32	19/32	1/4	11/32	9/32	5/32	3/16
CL-1-CS				2-1/2	1-3/32	13/16					
CL-1A-CS	5/16-18 or M8	1/2	3/4	2-1/2	27/32	1/2	5/16	7/16	11/32	7/32	1/4
CL-1B-CS				3	1-11/32	1					
CL-2-CS	3/8-16 or M10	1/2	1-1/8	3	1-9/32	7/8	13/32	1/2	27/64	9/32	3/8
CL-3A-CS				3-1/2	1-17/32	1-1/8					
CL-3-CS				4	1-25/32	1-3/8					
CL-4-CS				5	2-9/32	1-7/8					
CL-5-CS				6	2-25/32	2-3/8					
CL-6A-CS	1/2-13 or M12	5/8	1-1/4	3-1/2	1-1/2	1-1/32	13/32	1/2	17/32	9/32	3/8
CL-6-CS				4	1-3/4	1-9/32					
CL-8-CS				5	2-1/4	1-25/32					
CL-10-CS				6	2-3/4	2-9/32					
CL-15A-CS				4	1-11/16	1-3/32					
CL-16-CS	5/8-11 or M16	7/8	1-1/2	5	2-3/16	1-19/32	1/2	19/32	21/32	9/32	1/2
CL-18-CS				6	2-11/16	2-3/32					
CL-18A-CS				6-1/2	2-15/16	2-11/32					
CL-19-CS	3/4-10 or M20	1	1-3/4	6	2-5/8	2	1/2	19/32	13/16	5/16	1/2
CL-21-CS				7	3-1/8	2-9/16					
CL-22A-CS				8	3-5/8	3-1/8					

STRAPS — STAINLESS, MINIATURE

CL-17215	#10-32	1/4	1/2	1-1/2	21/32	15/32	3/16	5/16	7/32	3/32	7/32
CL-17325	1/4-20	3/8	5/8	2-1/2	1-1/8	15/16	1/4	3/8	9/32	1/8	9/32
CL-17540	3/8-16	1/2	1	4	1-13/16	1-1/2	3/8	1/2	13/32	3/16	13/32

SLOTTED-HEEL CLAMP STRAPS

INFO+: SEE PAGES 100, 109, 263, 311-316, 318-319, 326, 327-330 FOR MATERIAL SPECIFICATIONS

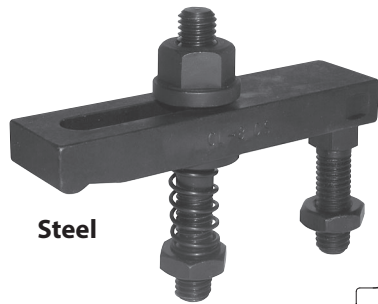

Steel

A complete clamp-strap assembly using a slotted-heel strap from (INFO+ page 262). Select any of the six nut/knob combinations shown below by adding the appropriate suffix to the part number. Other Stud and Clamp Rest lengths are available (order pieces individually).

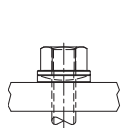

Spherical Nut & Washer
CL-xx-SHA-1

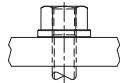

Flange Nut
CL-xx-SHA-2

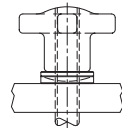

Hand Knob with Spherical Washer
CL-xx-SHA-4

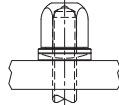

Acorn Nut with Spherical Washer
CL-xx-SHA-5

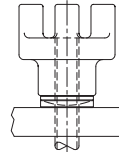

Bar Knob with Spherical Washer*
CL-xx-SHA-6

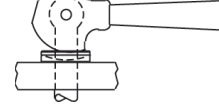

Cam Handle with Spherical Washer

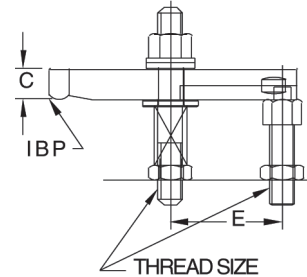
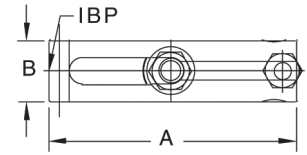

ASSEMBLIES — STEEL (INCH)

PART NO.	THREAD SIZE	A	B	C	E	CLAMP STRAP	CLAMP REST	SPRING	FLAT WASHER	STUD
CL-0-SHA-x	1/4-20	2	5/8	3/8	27/32	CL-0-CS	CL-1-CR	CL-5-SPG	CL-7-FW	CL-1/4-20x2.50-STUD
CL-1-SHA-x		2-1/2			1-3/32	CL-1-CS				
CL-1A-SHA-x	5/16-18	2-1/2	3/4		1-1/4	CL-1A-CS	CL-1A-CR	CL-6-SPG	CL-14-FW	CL-5/16-18x3.00-STUD
CL-1B-SHA-x		3			1-11/32	CL-1B-CS				
CL-2-SHA-x		3		1/2	1-9/32	CL-2-CS				
CL-3-SHA-x		3-1/2			1-17/32	CL-3A-CS	CL-2-CR	CL-7-SPG	CL-1-FW	CL-3/8-16x3.00-STUD
CL-4-SHA-x	3/8-16	4	1-1/8		1-25/32	CL-3-CS				
CL-6-SHA-x		5			2-9/32	CL-4-CS				
CL-8-SHA-x		6			2-25/32	CL-5-CS				
CL-9-SHA-x		3-1/2			1-1/2	CL-6A-CS	CL-4-CR	CL-9-SPG	CL-2-FW	CL-1/2-13x4.00-STUD
CL-10-SHA-x		4		5/8	1-3/4	CL-6-CS				
CL-12-SHA-x	1/2-13	5	1-1/4		2-1/4	CL-8-CS				
CL-14-SHA-x		6			2-3/4	CL-10-CS				
CL-20-SHA-x		4			1-11/16	CL-15A-CS	CL-5-CR	CL-11-SPG	CL-3-FW	CL-5/8-11x4.50-STUD
CL-22-SHA-x		5		7/8	2-3/16	CL-16-CS				
CL-24-SHA-x	5/8-11	6	1-1/2		2-11/16	CL-18-CS				
CL-25-SHA-x		6-1/2			2-15/16	CL-18A-CS				
CL-27-SHA-x		6			2-5/8	CL-19-CS	CL-8-CR	CL-13-SPG	CLM-10-FW	CL-3/4-10x5.00-STUD
CL-29-SHA-x	3/4-10	7	1-3/4	1	3-1/8	CL-21-CS				
CL-31-SHA-x		8			3-5/8	CL-22A-CS				

ASSEMBLIES — STEEL (METRIC)

PART NO.	THREAD SIZE	THREAD PITCH (mm)	A (mm)	B (mm)	C (mm)	E (mm)	CLAMP STRAP	CLAMP REST	CLAMP SPRING	FLAT WASHER	CLAMPING STUD	JAM NUT	SPHERICAL NUT & WASHER
CLM-0-SHA-1	M6	1	51	16	9.5	21.5	CL-0-CS	CLM-1-CR	CL-5-SPG	CL-7-FW	CLM-6 x 65-STUD	CLM-6-JN	CLM-6-SNW
CLM-1-SHA-1			63.5			28	CL-1-CS						
CLM-1A-SHA-1	M8	1.25		19		32	CL-1A-CS	CLM-1A-CR	CL-6-SPG	CL-14-FW	CLM-8 x 80-STUD	CLM-8-JN	CLM-8-SNW
CLM-1B-SHA-1			76			34	CL-1B-CS						
CLM-2-SHA-1			89		12.5	32.5	CL-2-CS						
CLM-3-SHA-1			89			39	CL-3A-CS	CLM-2-CR	CL-7-SPG	CL-1-FW	CLM-10 x 80-STUD	CLM-10-JN	CLM-10-SNW
CLM-4-SHA-1	M10	1.5	101.5	28.5		45	CL-3-CS						
CLM-6-SHA-1			127			58	CL-4-CS						
CLM-8-SHA-1			152			70.5	CL-5-CS						
CLM-9-SHA-1			89			38	CL-6A-CS	CLM-4-CR	CL-9-SPG	CL-2-FW	CLM-12 x 95-STUD	CLM-12-JN	CLM-12-SNW
CLM-10-SHA-1	M12	1.75	101.5	32	16	44.5	CL-6-CS						
CLM-12-SHA-1			127			57	CL-8-CS						
CLM-14-SHA-1			152			70	CL-10-CS						
CLM-20-SHA-1			101.5			43	CL-15A-CS	CLM-5-CR	CL-11-SPG	CL-3-FW	CLM-16 x 110-STUD	CLM-16-JN	CLM-16-SNW
CLM-22-SHA-1	M16	2	127	38	22	55.5	CL-16-CS						
CLM-24-SHA-1			152			68.5	CL-18-CS						
CLM-25-SHA-1			165			75	CL-18A-CS						
CLM-27-SHA-1			152			66.5	CL-19-CS	CLM-8-CR	CL-13-SPG	CLM-10-FW	CLM-20 x 125-STUD	CLM-20-JN	CLM-20-SNW
CLM-29-SHA-1	M20	2.5	178	44.5	25.5	79.5	CL-21-CS						
CLM-31-SHA-1			203			92	CL-22A-CS						

SLOTTED-HEEL CLAMP STRAPS

INFO+: SEE PAGES 100, 109, 263, 311-316, 318-319, 326, 327-330 FOR MATERIAL SPECIFICATIONS



**Straddle Cam
Steel**

A complete clamp-strap assembly using (INFO+) a slotted-heel strap from page 262 along with a Double Cam and Eyebolt. Other Eyebolt and Clamp Rest lengths are available (order pieces individually).

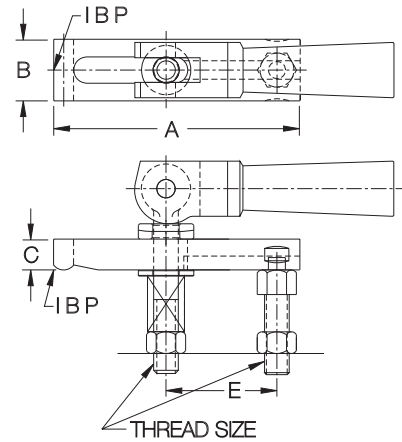

ASSEMBLIES — STRADDLE CAM, STEEL (INCH)

PART NO.	THREAD SIZE	A	B	C	E	CLAMP STRAP	CLAMP REST	SPRING	EYE BOLT	CAM HANDLE AND CLEVIS PIN	FLAT WASHER	SPHERICAL WASHER
CL-0-SCA	1/4-20	2	5/8	3/8	27/32	CL-0-CS	CL-1-CR	CL-5-SPG	CL-25-EB	CL-11-CH	CL-7-FW	CL-1-SW
CL-1-SCA		2-1/2			1-3/32	CL-1-CS				CL-610-CLVP		
CL-1A-SCA	5/16-18	2-1/2	3/4	1/2	1-1/4	CL-1A-CS	CL-1A-CR	CL-6-SPG	CL-31-EB	CL-11A-CH	CL-14-FW	CL-11-SW
CL-1B-SCA		3			1-11/32	CL-1B-CS				CL-810-CLVP		
CL-2-SCA	3/8-16	3	1-1/8	1/2	1-9/32	CL-2-CS	CL-2-CR	CL-7-SPG	CL-38-EB	CL-12-CH	CL-1-FW	CL-2-SW
CL-2A-SCA		3-1/2			1-17/32	CL-3A-CS						
CL-3-SCA		4			1-25/32	CL-3-CS						
CL-4-SCA		5			2-9/32	CL-4-CS						
CL-5-SCA		6			2-25/32	CL-5-CS						
CL-6A-SCA		3-1/2			1-1/2	CL-6A-CS						
CL-6-SCA	1/2-13	4	1-1/4	5/8	1-3/4	CL-6-CS	CL-4-CR	CL-9-SPG	CL-50-EB	CL-13-CH	CL-2-FW	CL-3-SW
CL-8-SCA		5			2-1/4	CL-8-CS						
CL-9A-SCA		6			2-3/4	CL-10-CS						
CL-17-SCA		4			1-11/16	CL-15A-CS						
CL-19-SCA	5/8-11	5	1-1/2	7/8	2-3/16	CL-16-CS	CL-6-CR	CL-11-SPG	CL-62-EB	CL-14-CH	CL-3-FW	CL-4-SW
CL-21-SCA		6			2-11/16	CL-18-CS						
CL-22-SCA		6-1/2			2-15/16	CL-18A-CS						
CL-24-SCA		6			2-5/8	CL-19-CS						
CL-26-SCA	3/4-10	7	1-3/4	1	3-1/8	CL-21-CS	CL-8-CR	CL-13-SPG	CL-75-EB	CL-15-CH	CL-4-FW	CL-5-SW
CL-28-SCA		8			3-5/8	CL-22A-CS						

ASSEMBLIES — STRADDLE CAM, STEEL (METRIC)

CLM-0-SCA	M6	2	5/8	3/8	27/32	CL-0-CS	CLM-1-CR	CL-5-SPG	CLM-25A-EB	CLM-11-CH	CL-7-FW	CL-1-SW
CLM-1-SCA	M6	2-1/2	5/8	3/8	1-3/32	CL-1-CS	CLM-1-CR	CL-5-SPG	CLM-25A-EB	CLM-616-CLVP	CL-7-FW	CL-1-SW
CLM-2-SCA		3			1-9/32	CL-2-CS						
CLM-2A-SCA	M10	3-1/2	1-1/8	1/2	1-17/32	CL-3A-CS	CLM-2-CR	CL-7-SPG	CLM-40-EB	CLM-12-CH	CL-1-FW	CL-2-SW
CLM-3-SCA		4			1-25/32	CL-3-CS						
CLM-4-SCA		5			2-9/32	CL-4-CS						
CLM-5-SCA		6			2-25/32	CL-5-CS						
CLM-6A-SCA		3-1/2			1-1/2	CL-6A-CS						
CLM-6-SCA		M12			4	1-1/4						
CLM-8-SCA	5		2-1/4	CL-8-CS								
CLM-9A-SCA	6		2-3/4	CL-10-CS								
CLM-17-SCA	4		1-11/16	CL-15A-CS								
CLM-19-SCA	M16	5	1-1/2	7/8	2-3/16	CL-16-CS	CLM-5-CR	CL-11-SPG	CLM-62-EB	CLM-14-CH	CL-3-FW	CL-4-SW
CLM-21-SCA		6			2-11/16	CL-18-CS						
CLM-22-SCA		6-1/2			2-15/16	CL-18A-CS						
CLM-24-SCA		6			2-5/8	CL-19-CS						
CLM-26-SCA	M20	7	1-3/4	1	3-1/8	CL-21-CS	CLM-8-CR	CL-13-SPG	CLM-76A-EB	CLM-15-CH	CLM-10-FW	CLM-20-SW
CLM-28-SCA		8			3-5/8	CL-22A-CS						

SLOTTED-HEEL CLAMP STRAPS

INFO+: SEE PAGES 123, 263, 311-316, 318-319, 329-330 FOR MATERIAL SPECIFICATIONS

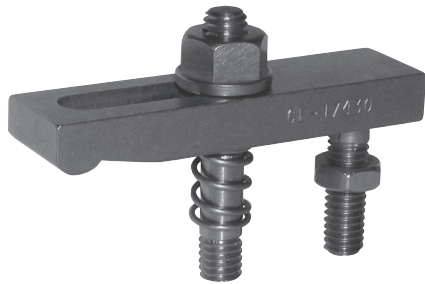

**Stainless Steel
(Miniature)**

A complete clamp-strap assembly using (**INFO+**) a stainless steel slotted-heel strap from page 262. Select any of the four nut/knob combinations shown below by adding the appropriate suffix to the part number. Fixture Stud has a thread-locking interference thread at the bottom end to install permanently in a fixture plate.

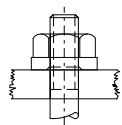

Flange Nut

CL-xxxx-1

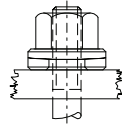

Spherical Nut
and Washer

CL-xxxx-2

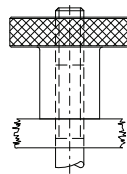

Knurled
Knob

CL-xxxx-3

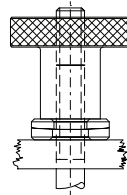

Knurled Knob
and Spherical
Washer

CL-xxxx-4

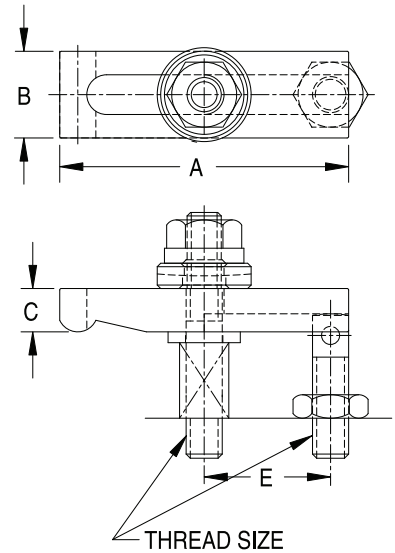

7

ASSEMBLIES — STAINLESS, MINIATURE (INCH)

PART NO.	THREAD SIZE	A	B	C	E	CLAMP STRAP	CLAMP REST	SPRING	FLAT WASHER	STUD	JAM NUT
CL-2715-x	#10-32	1-1/2	1/2	1/4	21/32	CL-17215	CL-13410	CL-2430.7	CL-254	CL-11415	CL-3-FJN-S
CL-2825-x	1/4-20	2-1/2	5/8	3/8	1-1/8	CL-17325	CL-13515	CL-2440.7	CL-255	CL-11520	CL-4-JN-S
CL-2925-x	5/16-18	2-1/2	3/4	3/8	1-3/32	CL-17425	CL-13615	CL-2450.7	CL-256	CL-11620	CL-5-JN-S
CL-3040-x	3/8-16	3	1	1/2	1-5/16	CL-17530	CL-13717	CL-2461.0	CL-257	CL-11725	CL-6-JN-S

SLOTTED-HEEL GOOSENECK CLAMP STRAPS

STRAP: ALLOY STEEL, BLACK OXIDE FINISH

INFO+: SEE PAGES 101, 311-316, 318-319, 327, 329-330 FOR OTHER MATERIAL SPECIFICATIONS

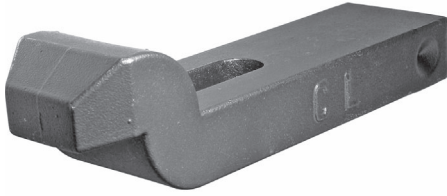

Gooseneck version of our Slotted-Heel Clamp Straps. This design recesses the clamping nut to provide a low overall profile. Slotted-Heel Clamp Straps have a slot underneath to slide straight back for clear loading. An indentation at the rear of each side provides a secure finger grip for retracting the clamp. Available to fit 1/2-13 studs (M12 in metric).

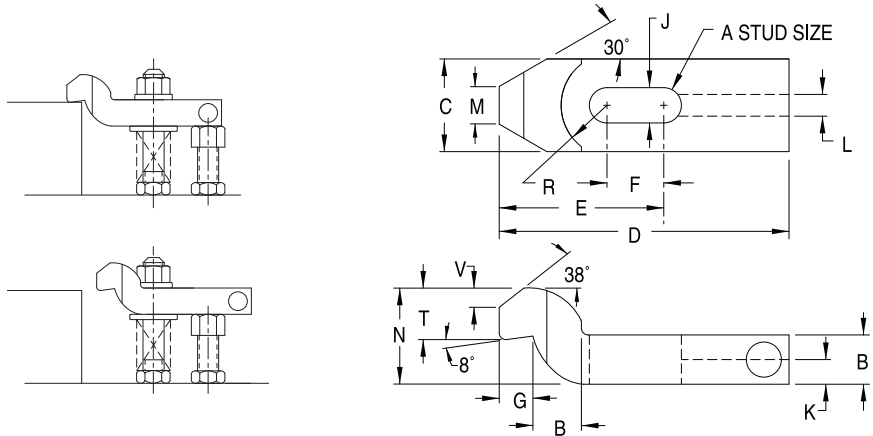

STRAPS – STEEL

PART NO.	A	B	C	D	E	F	G	J	K	L	M	N	R	T	V
CL-85-GCS	1/2 OR M12	.79	1.57	4.92	2.87	1.02	.63	.55	.34	.38	.79	1.57	.79	.90	.34

7

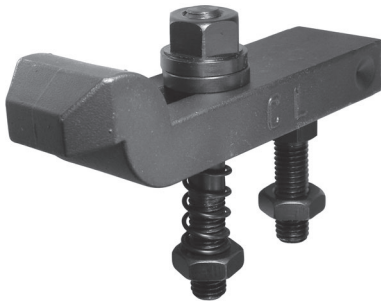

Slotted-Heel Gooseneck Clamp Straps are also available as a complete assembly. Select any of the five nut/knob combinations shown below by adding the appropriate suffix to the part number. Other lengths of Clamping Studs and Clamp Rests are available (order pieces individually).

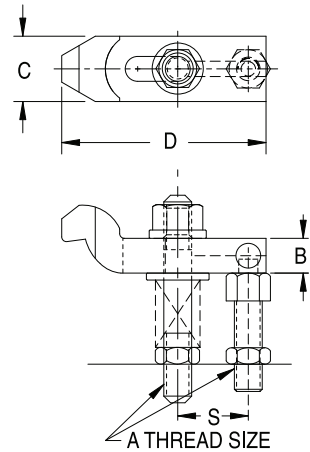

Spherical Nut & Washer
CL-xx-GCSA-1

Flange Nut
CL-xx-GCSA-2

Hand Knob with Spherical Washer
CL-xx-GCSA-4

Acorn Nut with Spherical Washer
CL-xx-GCSA-5

Cam Handle with Spherical Washer
CL-xx-GCSA-7

ASSEMBLIES – STEEL (INCH)

PART NO.	A	B	C	D	S	CLAMP STRAP	CLAMP REST	SPRING	FLAT WASHER	STUD	JAM NUT
CL-85-GCSA-x	1/2 OR M12	.79	1.57	5.91	2.75	CL-85-GCS	CL-4-CR	CL-9-SPG	CL-2-FW	CL-1/2-13X4.00-STUD	CL-8-JN

ASSEMBLIES – STEEL (METRIC)

PART NO.	A	B	C	D	S	CLAMP STRAP	CLAMP REST	SPRING	FLAT WASHER	STUD	JAM NUT
CLM-85-GCSA-x	1/2 OR M12	20mm	40mm	150mm	70mm	CL-85-GCS	CLM-4-CR	CL-9-SPG	CL-2-FW	CLM-12X95-STUD	CLM-12-JN

SLOTTED-HEEL PADDED CLAMP STRAPS

STRAP & PAD: 1018 STEEL, CARBURIZED-HARDENED, BLACK OXIDE FINISH
INFO+: SEE PAGES 101, 311-316, 318, 329-330 FOR OTHER MATERIAL SPECIFICATIONS



Steel

Slotted-Heel Clamp Strap that features a replaceable clamping pad attached with two screws (furnished). Clamp Strap also easily accepts custom pads or other attachments. Rear end is tapped on either side for a Finger Pin. Available for 1/4-20 (M6) to 1/2-13 (M12) stud sizes, most in a choice of several strap lengths.

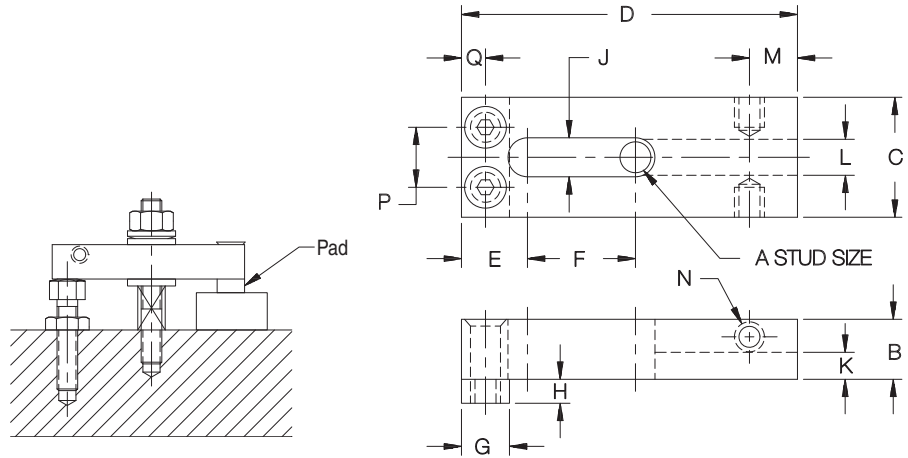

STRAPS — STEEL WITH STEEL PAD

PART NO.	A	B	C	D	E	F	G	H	J	K	L	M	N	P	Q
CL-165-CS	1/4-20 or M6	3/8	5/8	2	3/8	5/8	1/4	1/8	9/32	5/32	1/4			11/32	9/64
CL-166-CS	3/8-16 or M10	5/8	1-1/4	3-1/2	11/16	1-1/8	1/2	1/4	27/64	9/32	3/8	1/2	5/16-18	5/8	1/4
CL-168-CS				4-1/2		1-5/8									
CL-169-CS	1/2-13 or M12	3/4	1-1/2	4-1/2	7/8	1-1/4	5/8	3/8	17/32	9/32	3/8	1/2	5/16-18	3/4	5/16
CL-170A-CS				6		2									

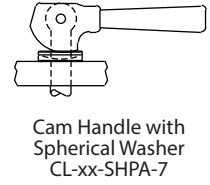
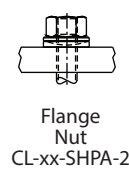
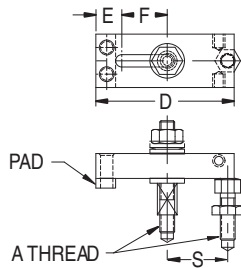

ASSEMBLIES — STEEL WITH STEEL PAD (INCH)

PART NO.	A	D	E	F	S	CLAMP STRAP	CLAMP REST	SPRING	FLAT WASHER	CLAMPING STUD
CL-165-SHPA-x	1/4-20	2	3/8	5/8	7/8	CL-165-CS	CL-1-CR	CL-5-SPG	CL-7-FW	CL-1/4-20x2.50-STUD
CL-166-SHPA-x	3/8-16	3-1/2	11/16	1-1/8	1-7/16	CL-166-CS	CL-2-CR	CL-7-SPG	CL-1-FW	CL-3/8-16x3.00-STUD
CL-168-SHPA-x				4-1/2	1-5/8	1-15/16				
CL-169-SHPA-x	1/2-13	4-1/2	7/8	1-1/4	2-1/8	CL-169-CS	CL-4-CR	CL-9-SPG	CL-2-FW	CL-1/2-13x4.00-STUD
CL-170A-SHPA-x				6	2-7/8	CL-170A-CS				

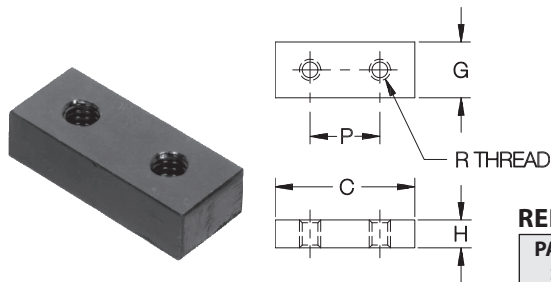

Replacement or optional pads for the Clamp Straps shown above. Available in steel, reinforced plastic, or brass.

REPLACEMENT PADS

PART NO. STEEL PAD	PART NO. PLASTIC PAD	PART NO. BRASS PAD	STUD SIZE	C	G	H	P	R
CL-40-CP	CL-20-CP	CL-30-CP	1/4-20 or M6	5/8	1/4	1/8	11/32	#5-40
CL-42-CP	CL-22-CP	CL-32-CP	3/8-16 or M10	1-1/4	1/2	1/4	5/8	#10-24
CL-43-CP	CL-23-CP	CL-33-CP	1/2-13 or M12	1-1/2	5/8	3/8	3/4	1/4-20

TAPPED-HEEL CLAMP STRAPS

STEEL: 1018, CARBURIZED-HARDENED, BLACK OXIDE FINISH
 STAINLESS STEEL: 300 SERIES



**Steel and
Stainless Steel**

Popular Clamp Strap with a tapped heel that accepts a clamping screw or rear support. Often used with a Guide Block to allow sliding the strap straight back for clear loading. Two drill spots on the sides provide a secure grip for retracting the clamp. **INFO+**: Can also be used with a Stud Leveling Foot as a rear support.

Available in steel for 1/4-20 to 3/4-10 stud sizes (M6 to M20 in metric), or stainless steel for #10-32 to 3/8-16 stud sizes. Each size is available in several strap lengths.

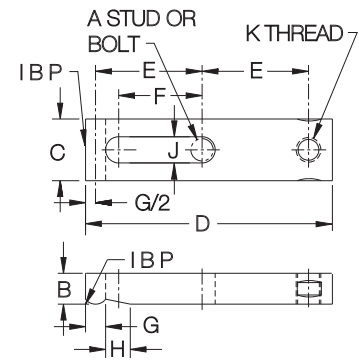

STRAPS — STEEL (INCH)

PART NO.	A	B	C	D	E	F	G	H	J	K
CL-61-CS	1/4-20	3/8	5/8	2	13/16	9/16	1/4	11/32	9/32	1/4-20
CL-62-CS				2-1/2	1-1/16	13/16				
CL-63-CS	3/8-16	1/2	1-1/8	3	1-7/32	13/16	13/32	1/2	27/64	3/8-16
CL-65-CS				4	1-23/32	1-5/16				
CL-67-CS				5	2-7/32	1-13/16				
CL-69-CS				6	2-23/32	2-5/16				
CL-70-CS	1/2-13	5/8	1-1/4	3-1/2	1-13/32	15/16	13/32	1/2	17/32	1/2-13
CL-71-CS				4	1-21/32	1-3/16				
CL-72-CS				4-1/2	1-29/32	1-7/16				
CL-73-CS				5	2-5/32	1-11/16				
CL-74-CS				5-1/2	2-13/32	1-15/16				
CL-75-CS	6	2-21/32	2-3/16							
CL-81-CS	5/8-11	7/8	1-1/2	4	1-9/16	1	1/2	19/32	21/32	5/8-11
CL-77-CS				4-1/2	1-13/16	1-1/4				
CL-83-CS				5	2-1/16	1-1/2				
CL-85-CS				6	2-9/16	2				
CL-86-CS				6-1/2	2-13/16	2-1/4				
CL-88-CS	3/4-10	1	1-3/4	6	2-1/2	1-29/32	1/2	19/32	13/16	3/4-10
CL-90-CS				7	3	2-13/32				
CL-92-CS				8	3-1/2	2-29/32				

STRAPS — STEEL (METRIC)

PART NO.	A STUD SIZE	B (mm)	C (mm)	D (mm)	E (mm)	F (mm)	G (mm)	H (mm)	J (mm)	K THREAD	THREAD PITCH (mm)
CLM-61-CS	M6	9.5	16	51	20.5	14.5	6.5	8.5	7	M6	1
CLM-62-CS	M6	9.5	16	63	27	20.5	6.5	8.5	7	M6	1
CLM-63-CS	M10	12.5	28.5	76	31	20.5	10.5	12.5	10.5	M10	1.5
CLM-65-CS	M10	12.5	28.5	101.5	43.5	33.5	10.5	12.5	10.5	M10	1.5
CLM-67-CS	M10	12.5	28.5	127	56.5	46	10.5	12.5	10.5	M10	1.5
CLM-70-CS	M12	16	32	89	35.5	24	10.5	12.5	13.5	M12	1.75
CLM-71-CS	M12	16	32	101.5	42	30	10.5	12.5	13.5	M12	1.75
CLM-72-CS	M12	16	32	114	48.5	36.5	10.5	12.5	13.5	M12	1.75
CLM-73-CS	M12	16	32	127	55	43	10.5	12.5	13.5	M12	1.75
CLM-75-CS	M12	16	32	162	67.5	55.5	10.5	12.5	13.5	M12	1.75
CLM-81-CS	M16	22	38	101.5	39.5	25.5	12.5	15	16.5	M16	2
CLM-83-CS	M16	22	38	127	52.5	38	12.5	15	16.5	M16	2
CLM-85-CS	M16	22	38	152	65	51	12.5	15	16.5	M16	2
CLM-88-CS	M20	25.5	44.5	152	63.5	48.5	12.5	15	20.5	M20	2.5
CLM-92-CS	M20	25.5	44.5	203	89	74	12.5	15	20.5	M20	2.5

STRAPS — STEEL (INCH)

PART NO.	A	B	C	D	E	F	G	H	J	K
CL-18215	#10-32	1/4	1/2	1-1/2	19/32	13/32	3/16	5/16	7/32	#10-32
CL-18220				2	27/32	21/32				
CL-18320	1/4-20	3/8	5/8	2	13/16	19/32	1/4	3/8	9/32	1/4-20
CL-18325				2-1/2	1-1/16	27/32				
CL-18540				3/8-16	1/2	1				

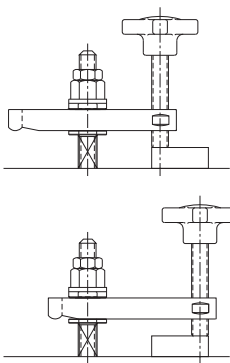

INFO+: See pages 270-272 for complete assemblies using these Clamp Straps.

TAPPED-HEEL CLAMP STRAPS

INFO+: SEE PAGES 100-101, 269, 311-316, 318-319, 330 FOR MATERIAL SPECIFICATION



Steel

A complete clamp-strap assembly using a tapped-heel strap from (**INFO+** page 269). Select one of two clamping screws or a rear Clamp Rest, as shown below, by adding the appropriate suffix to the part number.

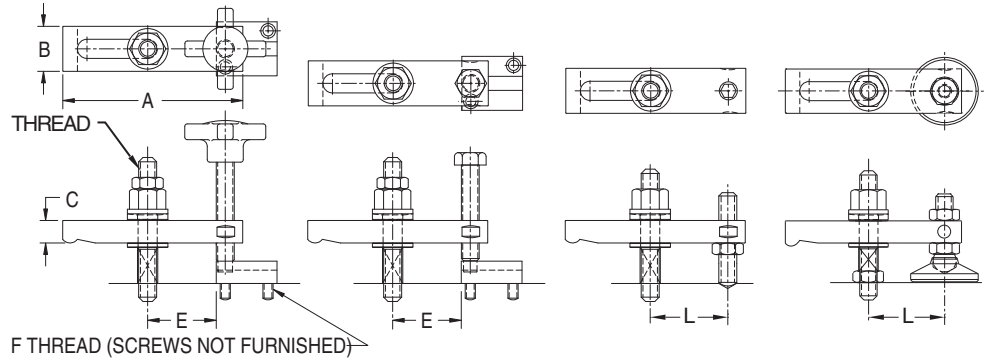

Hand-Knob Clamping Screw
CL-xx-THA-HK

Hex-Head Clamping Screw
CL-xx-THA-HH

Oval-Point Clamp Rest
CL-xx-THA-OP

Leveling Foot
CL-xx-THA-LF

ASSEMBLIES — STEEL (INCH)

PART NO.	THREAD SIZE	A	B	C	E	F	L	CLAMP STRAP	GUIDE BLOCK*	STUD & SPRING	NUTS	FLAT WASHER	
CL-1-THA-xx	1/4-20	2	5/8	3/8	11/16	#6-32	13/16	CL-61-CS	CL-2-GB	CL-1/4-20x2.00-STUD CL-5-SPG	CL-4-JN CL-1-SNW	CL-7-FW	
CL-2-THA-xx		2-1/2			15/16		1-1/16						CL-62-CS
CL-3-THA-xx	3/8-16	3	1-1/8	1/2	1-1/32	#10-32	1-7/32	CL-63-CS	CL-2-GB	CL-3/8-16x3.00-STUD CL-7-SPG	CL-6-JN CL-2-SNW	CL-1-FW	
CL-5-THA-xx		4			1-17/32		1-23/32						CL-65-CS
CL-7-THA-xx		5			2-1/32		2-7/32						CL-67-CS
CL-9-THA-xx		6			2-17/32		2-23/32						CL-69-CS
CL-10-THA-xx	1/2-13	3-1/2	1-1/4	5/8	1-5/32	1/4-20	1-13/32	CL-70-CS	CL-6-GB	CL-1/2-13x4.00-STUD CL-9-SPG	CL-8-JN CL-3-SNW	CL-2-FW	
CL-11-THA-xx		4			1-13/32		1-21/32						CL-71-CS
CL-12-THA-xx		4-1/2			1-21/32		1-29/32						CL-72-CS
CL-13-THA-xx		5			1-29/32		2-5/32						CL-73-CS
CL-14-THA-xx		5-1/2			2-5/32		2-13/32						CL-74-CS
CL-15-THA-xx		6			2-13/32		2-21/32						CL-75-CS
CL-17-THA-xx	5/8-11	4	1-1/2	7/8	1-1/4	1/4-20	1-9/16	CL-81-CS	CL-8-GB	CL-5/8-11x4.00-STUD CL-11-SPG	CL-10-JN CL-4-SNW	CL-3-FW	
CL-17-THA-xx		4-1/2			1-1/2		1-13/16						CL-77-CS
CL-23-THA-xx		5			1-3/4		2-1/16						CL-83-CS
CL-25-THA-xx		6			2-1/4		2-9/16						CL-85-CS
CL-26-THA-xx	6-1/2	2-1/2	2-13/16	CL-86-CS									
CL-28-THA-xx	3/4-10	6	1-3/4	1	2-1/8	1/4-20	2-1/2	CL-88-CS	CL-11-GB	CL-3/4-10x5.00-STUD CL-13-SPG	CL-12-JN CL-5-SNW	CL-4-FW	
CL-30-THA-xx		7			2-5/8		3						CL-90-CS
CL-32-THA-xx		8			3-1/8		3-1/2						CL-92-CS

ASSEMBLIES — STEEL (METRIC)

PART NO.	STUD THREAD	A (mm)	B (mm)	C (mm)	E (mm)	F THREAD	CLAMP STRAP	CLAMP SPRING	CLAMPING STUD	JAM NUTS	SPHERICAL NUT & WASHER	FLAT WASHER	HEX-HEAD CLAMPING SCREW	GUIDE BLOCK
CLM-1-THA-HH	M6	51	16	9.5	17.5	M4	CLM-61-CS	CL-5-SPG	CLM-6x65-STUD	(2) CLM-6-JN	CLM-6-SNW	CL-7-FW	CLM-1-THA-BOLT	CL-2-GB
CLM-2-THA-HH		65			24		CLM-62-CS							
CLM-3-THA-HH	M10	76	28.5	12.5	26	M5	CLM-63-CS	CL-7-SPG	CLM-10x80-STUD	(2) CLM-10-JN	CLM-10-SNW	CL-1-FW	CLM-2-THA-BOLT	CL-4-GB
CLM-5-THA-HH		101.5			39		CLM-65-CS							
CLM-7-THA-HH		127			51.5		CLM-67-CS							
CLM-10-THA-HH		89			29.5		CLM-70-CS							
CLM-11-THA-HH	M12	101.5	32	16	35.5	M6	CLM-71-CS	CL-9-SPG	CLM-12x95-STUD	(2) CLM-12-JN	CLM-12-SNW	CL-2-FW	CLM-3-THA-BOLT	CL-6-GB
CLM-12-THA-HH		114			42		CLM-72-CS							
CLM-13-THA-HH		127			48.5		CLM-73-CS							
CLM-15-THA-HH		152			61		CLM-75-CS							
CLM-21-THA-HH		101.5			32		CLM-81-CS							
CLM-23-THA-HH		M16			127		38							
CLM-25-THA-HH	152		57	CLM-85-CS										
CLM-28-THA-HH	M20	152	44.5	25.5	54	M6	CLM-88-CS	CL-13-SPG	CLM-20x125-STUD	(2) CLM-20-JN	CLM-20-SNW	CLM-10-FW	CLM-5-THA-BOLT	CL-11-GB
CLM-32-THA-HH		203			79.5		CLM-92-CS							

* Guide Block not included on oval-point version. For HK (hand-knob version), add "0" to Guide Block part number, e.g. CL-20-GB, CL-40-GB, etc.

TAPPED-HEEL CLAMP STRAPS

INFO+: 119, 203, 271, 313, 316, 318-319, 329-330 SEE PAGES FOR MATERIAL SPECIFICATIONS

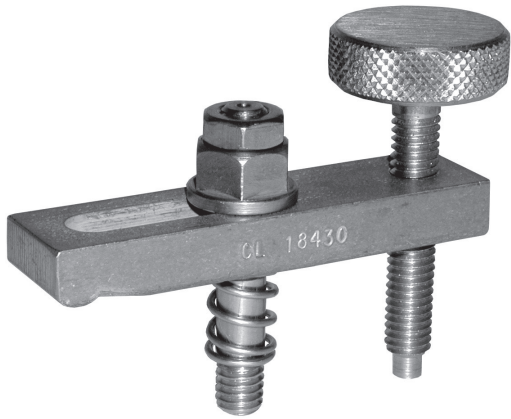

**Stainless Steel
(Miniature)**

A complete clamp-strap assembly using (INFO+) a stainless steel Tapped-Heel Strap from page 269. Fixture Stud has a thread-locking interference thread at the bottom end to install permanently in a fixture plate. Standard assembly includes a Knurled-Head Screw. To order with a rear Clamp Rest instead, add "-1" to the part number (example: CL-3115-1). To order with a Leveling Foot instead, add "-2" to the part number (example: CL-3115-2).

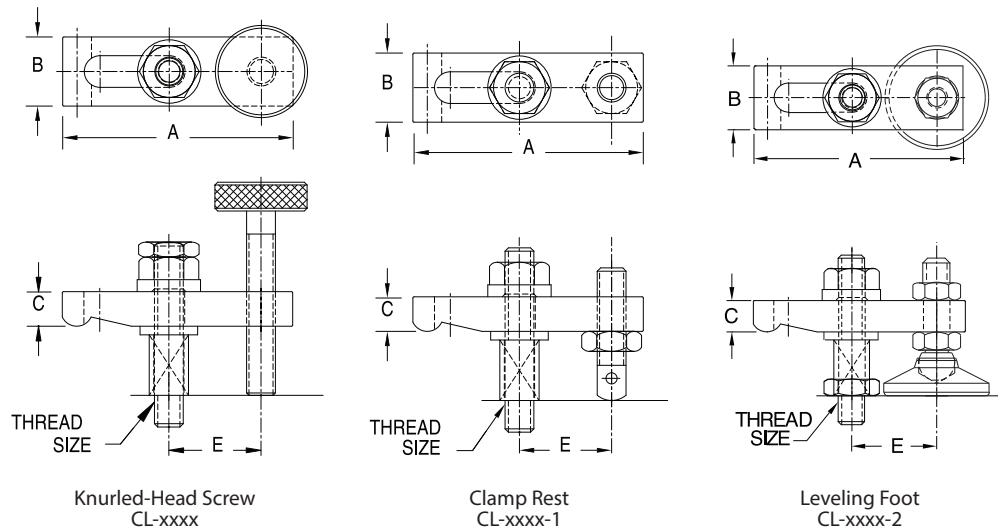

ASSEMBLIES — STAINLESS, MINIATURE (INCH)

PART NO. WITH KNURLED HEAD SCREW	THREAD SIZE	A	B	C	E	CLAMP STRAP	KNURLED HEAD SCREW	CLAMP REST	LEVELING FOOT	SPRING	FLAT WASHER	STUD	FLANGE NUT
CL-3115	#10-32	1-1/2	1/2	1/4	19/32	CL-18215	CL-23212	CL-13410	CL-3-SLF-S	CL-2430.7	CL-254	CL-11415	CL-124
CL-3120		2			27/32	CL-18220							
CL-3220	1/4-20	2	5/8	3/8	13/16	CL-18320	CL-23515	CL-13515	CL-4-SLF-S	CL-2440.7	CL-255	CL-11520	CL-125
CL-3225		2-1/2			1-1/16	CL-18325							
CL-3320	5/16-18	2	3/4	3/8	3/4	CL-18420	CL-23620	CL-13615	CL-5-SLF-S	CL-2450.7	CL-256	CL-11620	CL-126
CL-3325		2-1/2			1	CL-18425							
CL-3330	3/8-16	3	1	1/2	1-1/4	CL-18430	CL-23820	CL-13717	CL-6-SLF-S	CL-2461.0	CL-257	CL-11725	CL-127
CL-3435		3-1/2			1-15/32	CL-18535							
CL-3440		4			1-23/32	CL-18540							

TAPERED-NOSE CLAMP STRAPS

STRAP: 300-SERIES STAINLESS STEEL

INFO+: SEE PAGES 117, 313, 316, 318-319, 329-330 FOR OTHER MATERIAL SPECIFICATIONS



**Stainless Steel
(Miniature)**

Tapped-Heel Clamp Strap with a tapered nose for clamping in tight spaces. Available in stainless steel for #10-32 to 3/8-16 stud sizes.

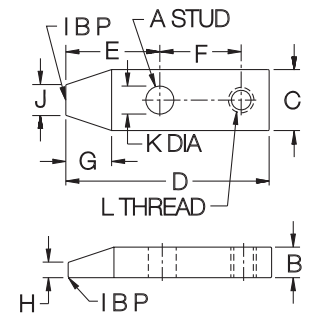

STRAPS — STAINLESS, MINIATURE (INCH)

PART NO.	A	B	C	D	E	F	G	H	J	K	L
CL-20215	#10-32	1/4	1/2	1-1/2	11/16	19/32	3/8	1/8	1/4	7/32	#10-32
CL-20220				2	15/16	27/32					
CL-20320	1/4-20	3/8	5/8	2	15/16	13/16	15/32	5/32	5/16	9/32	1/4-20
CL-20325				2-1/2	1-3/16	1-1/16					
CL-20425	5/16-18	3/8	3/4	2-1/2	1-5/32	1	9/16	3/16	3/8	11/32	5/16-18
CL-20535	3/8-16	1/2	1	3-1/2	1-21/32	1-15/32	3/4	1/4	1/2	27/64	3/8-16



**Stainless Steel
(Miniature)**

A complete clamp-strap assembly using one of the straps shown above. Fixture Stud has a thread-locking interference thread at the bottom end to install permanently in a fixture plate. Standard assembly includes a Knurled-Head Screw. To order with a rear Clamp Rest instead, add "-1" to the part number. Example: CL-3915-1.

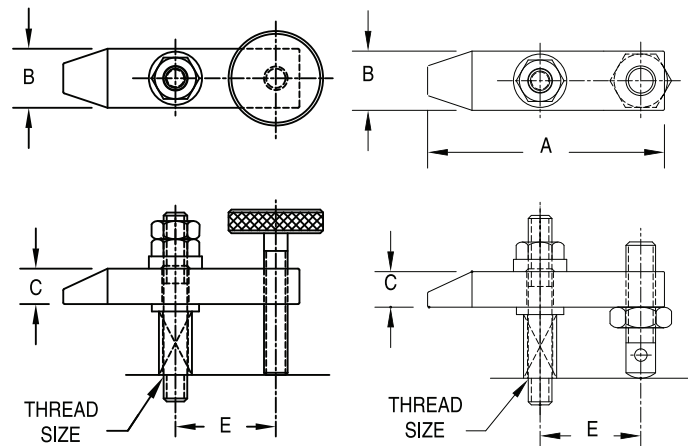

Knurled-Head Screw
CL-xxxx

Clamp Rest
CL-xxxx-1

ASSEMBLIES — STAINLESS, MINIATURE (INCH)

PART NO. WITH KNURLED HEAD SCREW	PART NO. WITH CLAMP REST	THREAD SIZE	A	B	C	E	CLAMP STRAP	KNURLED HEAD SCREW	CLAMP REST	SPRING	FLAT WASHER	STUD	FLANGE NUT
CL-3915	CL-3915-1	#10-32	1-1/2	1/2	1/4	19/32	CL-20215	CL-23212	CL-13410	CL-2430.7	CL-254	CL-11415	CL-124
CL-3920	CL-3920-1		2			27/32	CL-20220						
CL-4020	CL-4020-1	1/4-20	2	5/8	3/8	13/16	CL-20320	CL-23515	CL-13515	CL-2440.7	CL-255	CL-11520	CL-125
CL-4025	CL-4025-1		2-1/2			1-1/16	CL-20325						
CL-4125	CL-4125-1	5/16-18	2-1/2	3/4	3/8	1	CL-20425	CL-23620	CL-13615	CL-2450.7	CL-256	CL-11620	CL-126
CL-4235	CL-4235-1	3/8-16	3-1/2	1	1/2	1-15/32	CL-20535	CL-23820	CL-13717	CL-2461.0	CL-257	CL-11725	CL-127

WIDE-NOSE CLAMP STRAPS

STRAP: 300-SERIES STAINLESS STEEL

INFO+: SEE PAGES 117, 203, 313, 316, 318-319, 329-330 FOR OTHER MATERIAL SPECIFICATIONS



**Stainless Steel
(Miniature)**

Tapped-Heel Clamp Strap with an extra-wide nose. Available in stainless steel for 1/4-20 studs.

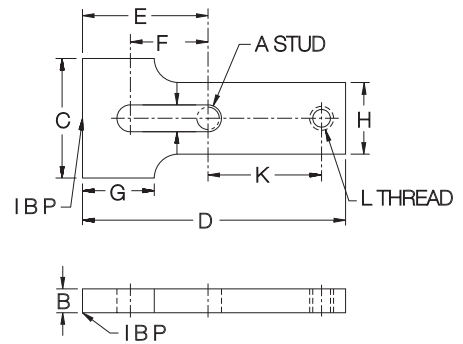

**Stainless Steel
(Miniature)**

STRAPS — STAINLESS, MINIATURE (INCH)

PART NO.	A	B	C	D	E	F	G	H	J	K	L
CL-22227	1/4-20	1/4	1-1/4	2-3/4	1-5/16	13/16	3/4	3/4	9/32	1-3/16	1/4-20

A complete Clamp-Strap assembly using the Clamp Strap shown above. Fixture stud has a thread-locking interference thread at the bottom end to install permanently in a fixture plate. Standard assembly includes a Knurled-Head Screw. To order with a rear Clamp Rest instead, add "-1" to the part number (CL-44227-1). To order with a levelling foot instead, add "-2" to the part number (CL-44227-2).

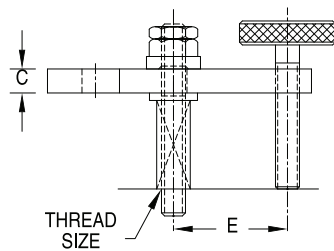
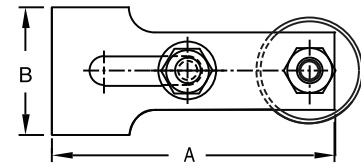
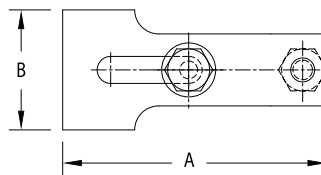
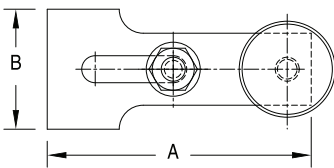

Knurled-Head Screw
CL-xxxx

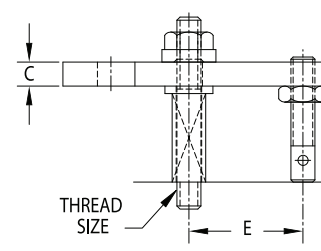

Clamp Rest
CL-xxxx-1

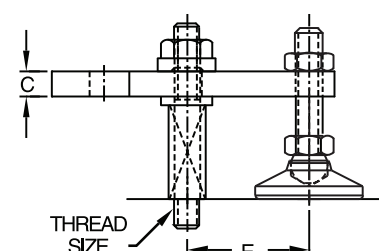

Levelling Foot
CL-xxxx-2

ASSEMBLIES — STAINLESS, MINIATURE (INCH)

PART NO. WITH KNURLED HEAD SCREW	THREAD SIZE	A	B	C	E	CLAMP STRAP	KNURLED HEAD SCREW	CLAMP REST	LEVELING FOOT	SPRING	FLAT WASHER	STUD	FLANGE NUT
CL-44227	1/4-20	2-3/4	1-1/4	1/4	1-3/16	CL-22227	CL-23515	CL-13515	CL-13515	CL-2440.7	CL-255	CL-11520	CL-125

TAPPED-HEEL PADDED CLAMP STRAPS

STRAP & PAD: 1018 STEEL, CARBURIZED-HARDENED, BLACK OXIDE FINISH
INFO+: SEE PAGES 101, 203, 312, 315-316, 318, 330 FOR OTHER MATERIAL SPECIFICATIONS

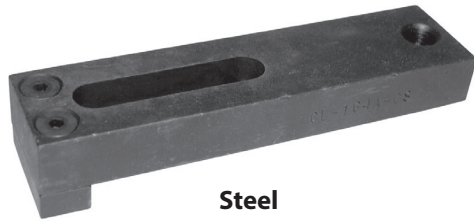

Steel

Tapped-Heel Clamp Strap that features a replaceable clamping pad attached with two screws (furnished). Clamp Strap also easily accepts custom pads or other attachments. Available for 1/4-20 to 1/2-13 stud sizes, most in a choice of several strap lengths.

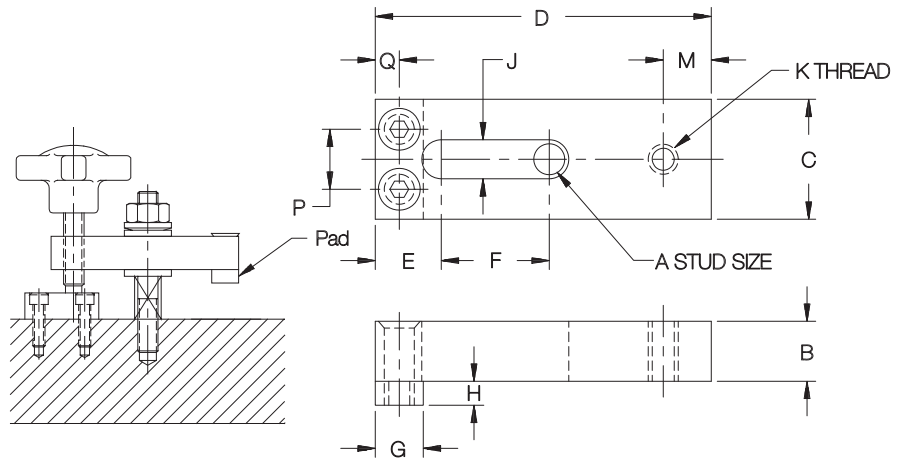

STRAPS — STEEL WITH STEEL PAD (INCH)

PART NO.	A	B	C	D	E	F	G	H	J	K	M	P	Q
CL-157-CS	1/4-20	3/8	5/8	2	3/8	5/8	1/4	1/8	9/32	1/4-20	7/32	11/32	9/64
CL-158A-CS	5/16-18	1/2	7/8	2-1/2	9/16	3/4	3/8	3/16	11/32	5/16-18	1/4	1/2	3/16
CL-159A-CS				3-1/2		1-1/4							
CL-160A-CS	3/8-16	5/8	1-1/4	3-1/2	11/16	1-1/8	1/2	1/4	27/64	3/8-16	3/8	5/8	1/4
CL-162A-CS				4-1/2		1-5/8							
CL-163A-CS	1/2-13	3/4	1-1/2	4-1/2	7/8	1-1/4	5/8	3/8	17/32	1/2-13	7/16	3/4	5/16
CL-164A-CS				6		2							

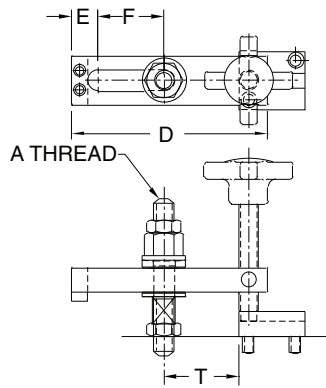

Hand-Knob Clamping Screw
CL-xx-THPA-HK

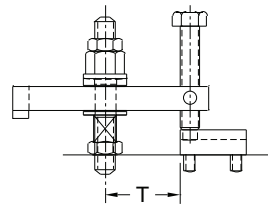

Hex-Head Clamping Screw
CL-xx-THPA-HH

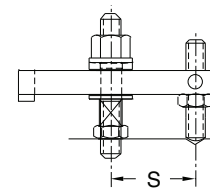

Oval-Point Clamp Rest
CL-xx-THPA-OP

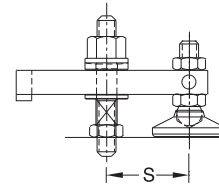

Leveling Foot
CL-xx-THPA-LF

ASSEMBLIES — STEEL WITH STEEL PAD (INCH)

PART NO.	A	D	E	F	S	T	CLAMP STRAP	GUIDE BLOCK*	SPRING	CLAMPING STUD	NUTS	FLAT WASHER
CL-157-THPA-xx	1/4-20	2	3/8	5/8	25/32	21/32	CL-157-CS	CL-2-GB	CL-5-SPG	CL-1/4-20x2.00-STUD	CL-4-JN CL-1-SNW	CL-7-FW
CL-160A-THPA-xx	3/8-16	3-1/2	11/16	1-1/8	1-5/16	1-1/8	CL-160A-CS	CL-4-GB	CL-7-SPG	CL-3/8-16x3.00-STUD	CL-6-JN CL-2-SNW	CL-1-FW
CL-162A-THPA-xx		4-1/2		1-5/8	1-13/16	1-5/8	CL-162A-CS					
CL-163A-THPA-xx	1/2-13	4-1/2	7/8	1-1/4	1-15/16	1-11/16	CL-163A-CS	CL-8-GB	CL-9-SPG	CL-1/2-13x4.00-STUD	CL-8-JN CL-3-SNW	CL-2-FW
CL-164A-THPA-xx		6		2	2-11/16	2-7/16	CL-164A-CS					

* Guide Block not included on oval-point version. For HK (hand-knob version), add "0" to Guide Block part number, e.g. CL-20-GB, CL-40-GB, etc.

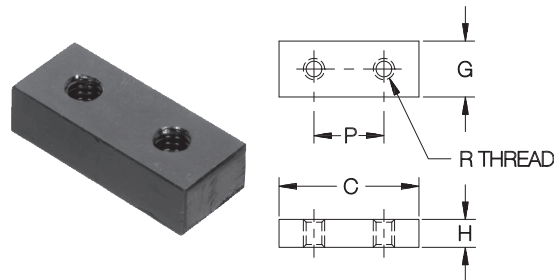

Replacement or optional pads for the Clamp Straps shown above. Available in steel, reinforced plastic, or brass.

REPLACEMENT PADS

PART NO. STEEL PAD	PART NO. PLASTIC PAD	PART NO. BRASS PAD	STUD SIZE	C	G	H	P	R
CL-40-CP	CL-20-CP	CL-30-CP	1/4-20	5/8	1/4	1/8	11/32	#5-40
CL-41-CP	CL-21-CP	CL-31-CP	5/16-18	7/8	3/8	3/16	1/2	#8-32
CL-42-CP	CL-22-CP	CL-32-CP	3/8-16	1-1/4	1/2	1/4	5/8	#10-24
CL-43-CP	CL-23-CP	CL-33-CP	1/2-13	1-1/2	5/8	3/8	3/4	1/4-20

FORGED CLAMP STRAPS

FORGED STEEL, 70,000 PSI YIELD STRENGTH, BLACK OXIDE FINISH



**Straight
Locator Nose**

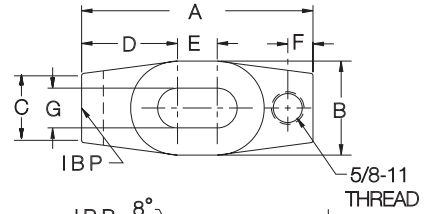

**Straight
Plain Nose**

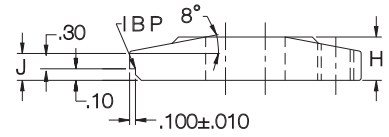

**Gooseneck
Locator Nose**

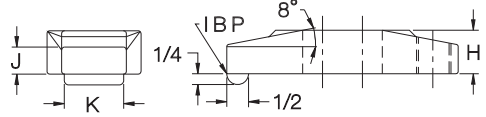

**Gooseneck
Plain Nose**

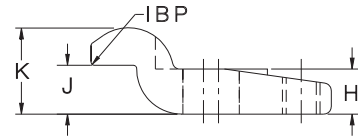
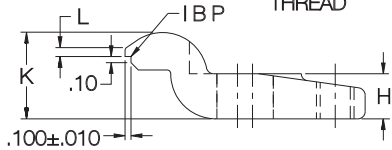
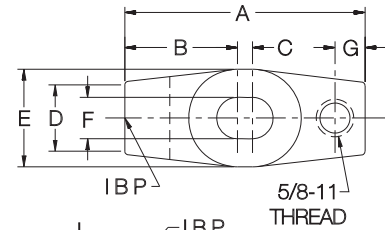

High-strength Tapped-Heel Clamp Strap available in straight or gooseneck design, with locator nose or plain nose. Locator-nose version is ideal for workpieces with machined sides. The accurately machined notch ensures precise, repeatable clamp location for increased machining clearance.

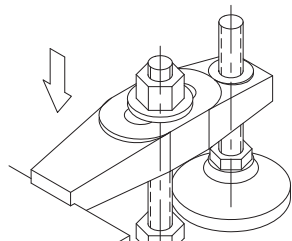

**Straight
Locator Nose
Clamp**

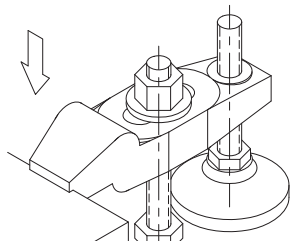

**Gooseneck
Locator Nose
Clamp**

STRAIGHT — LOCATOR NOSE (INCH)

PART NO.	STUD SIZE	A	B	C	D	E	F	G	H	J	K
CL-4-FSCS	5/8-11	4	1-5/8	1-3/16	1-21/32	11/16	7/16	11/16	3/4	1/2	-
CL-6-FSCS		6	1-3/4	1-1/4	2-5/16	1-3/8	9/16	11/16	7/8	9/16	-
CL-8-FSCS	3/4-10	8	2-1/8	1-1/2	3	2	11/16	13/16	1-1/8	3/4	-

STRAIGHT — PLAIN NOSE (INCH)

PART NO.	STUD SIZE	A	B	C	D	E	F	G	H	J	K	L
CL-4-FRCS	5/8-11	4	1-5/8	1-3/16	1-21/32	11/16	7/16	11/16	3/4	1/2	-	-
CL-6-FRCS		6	1-3/4	1-1/4	2-5/16	1-3/8	9/16	11/16	7/8	9/16	-	1
CL-8-FRCS	3/4-10	8	2-1/8	1-1/2	3	2	11/16	13/16	1-1/8	3/4	1-1/4	-

GOOSENECK — LOCATOR NOSE (INCH)

PART NO.	STUD SIZE	A	B	C	D	E	F	G	H	J	K	L
CL-40-FGNS	5/8-11	4	1-31/32	3/16	1-3/16	1-3/4	11/16	1/2	3/4	3/4	1-7/16	.15
CL-60-FGNS		6	2-17/32	1	1-1/4	1-3/4	11/16	5/8	7/8	15/16	1-9/16	.25
CL-80-FGNS	3/4-10	8	3-9/32	1-5/8	1-9/16	2-1/4	13/16	1	1-1/8	1-1/8	2	.35

GOOSENECK — PLAIN NOSE (INCH)

PART NO.	STUD SIZE	A	B	C	D	E	F	G	H	J	K	L
CL-4-FGNS	5/8-11	4	1-31/32	3/16	1-3/16	1-3/4	11/16	1/2	3/4	3/4	1-7/16	-
CL-6-FGNS		6	2-17/32	1	1-1/4	1-3/4	11/16	5/8	7/8	15/16	1-9/16	-
CL-8-FGNS	3/4-10	8	3-9/32	1-5/8	1-9/16	2-1/8	13/16	1	1-1/8	1-1/8	2	-

DOUBLE-END CLAMP STRAPS

STRAP: 1018 STEEL, CARBURIZED-HARDENED, BLACK OXIDE FINISH

INFO+: SEE PAGES 101, 109, 311-316, 318-319, 327-330 FOR OTHER MATERIAL SPECIFICATIONS



Steel

Clamp strap with two clamping ends, for holding two workpieces simultaneously. Available for 1/4-20 (M6) to 3/4-10 (M20) stud sizes, each in several strap lengths.

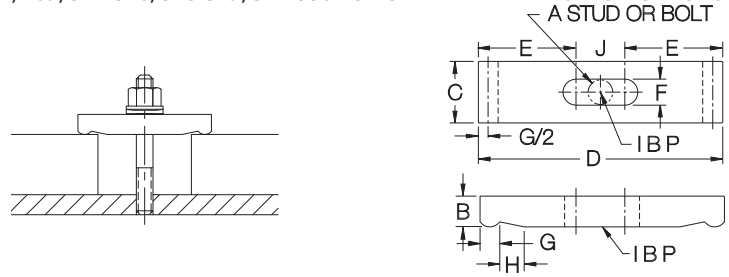

STRAPS — STEEL

PART NO.	A	B	C	D	E	F	G	H	J
CL-23B-CS	1/4-20 or M6	3/8	5/8	2-1/2	7/8	9/32	1/4	11/32	3/4
CL-23D-CS	5/16-18 or M8	1/2	3/4	3	1-1/2	3/8	5/16	7/16	0
CL-23-CS	3/8-16 or M10	1/2	1-1/8	3	1	27/64	13/32	1/2	1
CL-39-CS	3/4-10 or M20	1	1-3/4	6	3-1/8	13/16	1/25	19/32	1/3/4

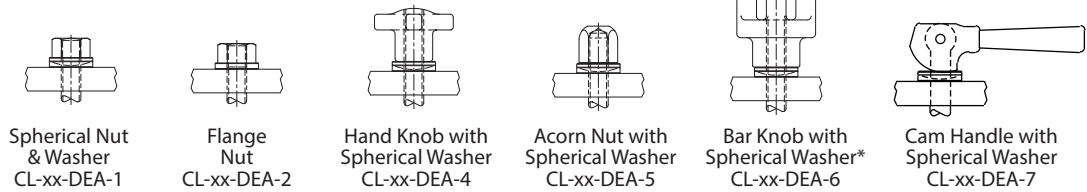

ASSEMBLIES — STEEL (INCH)



Steel

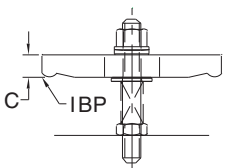
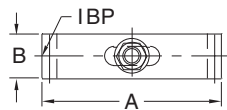

A complete clamp-strap assembly using one of the straps shown above. Select any of the six nut/knob combinations shown above by adding the appropriate suffix to the part number. Other stud lengths are available (order pieces individually).

PART NO.	THREAD SIZE	A	B	C	CLAMP STRAP	FLAT WASHER	SPRING & STUD
CL-1-DEA-x	1/4-20	2-1/2	5/8	3/8	CL-23B-CS	CL-7-FW	CL-1/4-20x2.50-STUD CL-5-SPG
CL-1B-DEA-x	5/16-18	3	3/4	1/2	CL-23D-CS	CL-14-FW	CL-5/16-18x3.00-STUD CL-6-SPG
CL-2-DEA-x	3/8-16		1-1/8	1/2	CL-23-CS	CL-1-FW	CL-3/8-16x3.00-STUD CL-7-SPG
CL-12-DEA-x	1/2-13	6	1-1/4	5/8	CL-30-CS	CL-2-FW	CL-1/2-13x4.00-STUD CL-9-SPG
CL-13-DEA-x	5/8-11		1-1/2	7/8	CL-33-CS	CL-3-FW	CL-5/8-11x4.50-STUD CL-11-SPG
CL-23-DEA-x	3/4-10	8	1-3/4	1	CL-39-CS	CL-4-FW	CL-3/4-10x5.00-STUD CL-13-SPG

ASSEMBLIES — STEEL (METRIC)

PART NO.	THREAD SIZE	A (mm)	B (mm)	C (mm)	CLAMP STRAP	CLAMP SPRING	FLAT WASHER	CLAMPING STUD	JAM NUT	SPHERICAL NUT & WASHER
CLM-0-DEA-1	M6	51	16	9.5	CL-23A-CS	CL-5-SPG	CL-7-FW	CLM-6x65-STUD	CLM-6-JN	CLM-6-SNW
CLM-1-DEA-1	M6	63.5	16	9.5	CL-23B-CS	CL-5-SPG	CL-7-FW	CLM-6x65-STUD	CLM-6-JN	CLM-6-SNW
CLM-1A-DEA-1	M8	51	19	12.5	CL-23C-CS	CL-6-SPG	CL-14-FW	CLM-8x80-STUD	CLM-8-JN	CLM-8-SNW
CLM-1B-DEA-1	M8	76	19	12.5	CL-23D-CS	CL-6-SPG	CL-14-FW	CLM-8x80-STUD	CLM-8-JN	CLM-8-SNW
CLM-2-DEA-1	M10	76	28.5	12.5	CL-23-CS	CL-7-SPG	CL-1-FW	CLM-10x80-STUD	CLM-10-JN	CLM-10-SNW
CLM-4-DEA-1	M10	101.5	28.5	12.5	CL-24-CS	CL-7-SPG	CL-1-FW	CLM-10x80-STUD	CLM-10-JN	CLM-10-SNW
CLM-6-DEA-1	M10	127	28.5	12.5	CL-25-CS	CL-7-SPG	CL-1-FW	CLM-10x80-STUD	CLM-10-JN	CLM-10-SNW
CLM-8-DEA-1	M12	101.5	32	16	CL-27-CS	CL-9-SPG	CL-2-FW	CLM-12x95-STUD	CLM-12-JN	CLM-12-SNW
CLM-10-DEA-1	M12	124	32	16	CL-28-CS	CL-9-SPG	CL-2-FW	CLM-12x95-STUD	CLM-12-JN	CLM-12-SNW
CLM-12-DEA-1	M12	152.5	32	16	CL-30-CS	CL-9-SPG	CL-2-FW	CLM-12x95-STUD	CLM-12-JN	CLM-12-SNW
CLM-15-DEA-1	M16	127	38	22	CL-32A-CS	CL-11-SPG	CL-3-FW	CLM-16x110-STUD	CLM-16-JN	CLM-16-SNW
CLM-13-DEA-1	M16	152.5	38	22	CL-33-CS	CL-11-SPG	CL-3-FW	CLM-16x110-STUD	CLM-16-JN	CLM-16-SNW
CLM-20-DEA-1	M20	152.5	44.5	25.5	CL-37-CS	CL-13-SPG	CLM-10-FW	CLM-20x125-STUD	CLM-20-JN	CLM-20-SNW
CLM-22-DEA-1	M20	178	44.5	25.5	CL-38-CS	CL-13-SPG	CLM-10-FW	CLM-20x125-STUD	CLM-20-JN	CLM-20-SNW
CLM-23-DEA-1	M20	203	44.5	25.5	CL-39-CS	CL-13-SPG	CLM-10-FW	CLM-20x125-STUD	CLM-20-JN	CLM-20-SNW

DOUBLE-END GOOSENECK CLAMP STRAPS

STRAP: ALLOY STEEL, BLACK OXIDE FINISH

INFO+: SEE PAGES 101, 311-316, 318, 329-330 FOR OTHER MATERIAL SPECIFICATIONS



Steel

Gooseneck version of our Double-End Clamp Straps. This design recesses the clamping nut to provide a low overall profile. Double-End Clamps have two clamping ends, for holding two workpieces simultaneously. Turn strap 90° for clear loading. Available to fit 1/2-13 and 5/8-11 studs (M12 and M16 in metric).

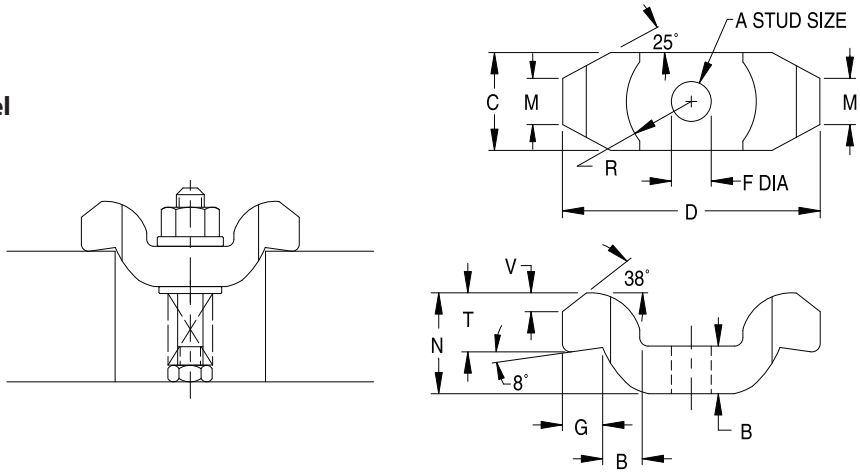

STRAPS – STEEL

PART NO.	A	B	C	D	F	G	M	N	R	T	V
CL-842-GCS	1/2-13, 5/8-11, M12, or M16	.79	1.58	3.94	.67	.63	.79	1.58	.94	.90	.34

7



Double-End Gooseneck Clamp Straps are also available as a complete assembly. Select any of the four nut/knob combinations shown below by adding the appropriate suffix to the part number. Other lengths of Clamping Studs and Clamp Rests are available (order pieces individually).

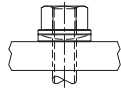
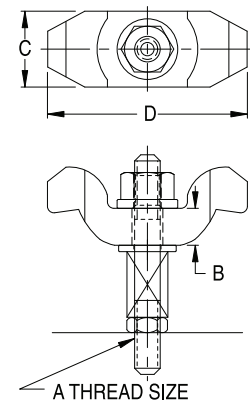

Spherical Nut & Washer
CL-xx-GCSA-1

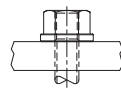

Flange Nut
CL-xx-GCSA-2

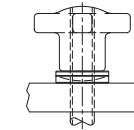

Hand Knob with Spherical Washer
CL-xx-GCSA-4

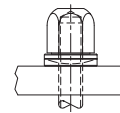

Acorn Nut with Spherical Washer
CL-xx-GCSA-5

ASSEMBLIES – STEEL (INCH)

PART NO.	A	B	C	D	CLAMP STRAP	FLAT WASHER	CLAMP SPRING	CLAMPING STUD	JAM NUT
CL-842-GCSA-x	1/2-13	.79	1.58	3.94	CL-842-GCS	CL-2-FW	CL-9-SPG	CL-1/2-13X4.00-STUD	CL-8-JN
CL-1042-GCSA-x	5/8-11					CL-3-FW	CL-11-SPG	CL-5/8-11X4.50-STUD	CL-10-JN

ASSEMBLIES – STEEL (METRIC)

PART NO.	A	B	C	D	CLAMP STRAP	FLAT WASHER	CLAMP SPRING	CLAMPING STUD	JAM NUT
CLM-842-GCSA-x	M12	1.75/2	20	40	CL-842-GCS	CL-2-FW	CL-9-SPG	CLM-12X95-STUD	CLM-12-JN
CLM-1042-GCSA-x	M16					CL-3-FW	CL-11-SPG	CLM-16X10-STUD	CLM-16-JN

ALUMINUM ADJUSTABLE CLAMPS

TENZALOY ALUMINUM ALLOY

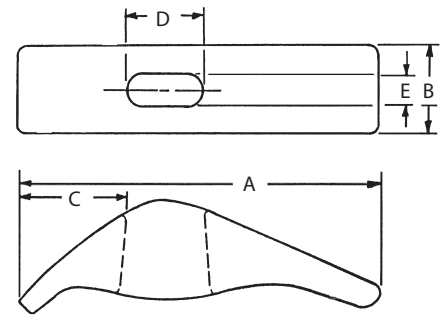

Simple, economical aluminum clamp, similar in function to the Forged Adjustable Clamps.

PART NO.	STUD SIZE	CLAMPING RANGE	A	B	C	D	E
CL-8-VAC	3/8 or M10	0 to 2"	4-7/8	1-1/4	1-3/8	1	13/32
CL-10-VAC	1/2 or M12	0 to 2-1/2"	5-1/2	1-1/2	1-1/2	1-1/8	17/32

FORGED U CLAMPS

FORGED STEEL, 70,000 PSI YIELD STRENGTH, BLACK OXIDE FINISH

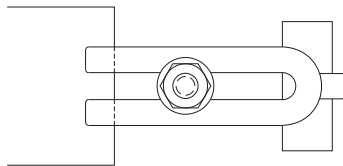
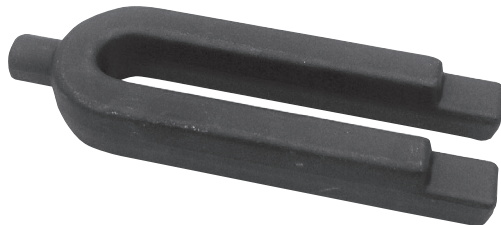

Open U end allows totally removing clamp strap when unclamped. Clamp tips are stepped to provide repeatable location.

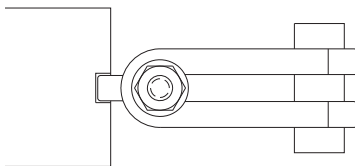

Cylindrical pin end minimizes contact area and is useful for clamping in horizontal holes.

PART NO.	BOLT SIZE	A	B	C	D	E	F	G	H
CL-6-FUC	5/8-11 or M16	5-7/16	2-1/4	7/8	11/16	3/4	5/16	3/4	3/4
CL-8-FUC	3/4-10 or M20	7-3/8	2-5/8	1-1/8	13/16	27/32	3/8	1-1/32	13/16
CL-12-FUC	1"-8 or M24	10-15/16	3-3/16	1-3/8	1-1/16	1-3/32	1/2	1-3/16	1-1/32

STEP BLOCKS & CLAMPS

1018 STEEL, CARBURIZED-HARDENED, BLACK OXIDE FINISH



Step Blocks (pair)

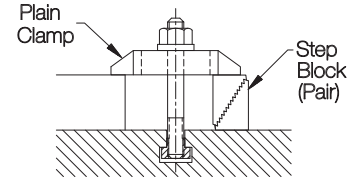
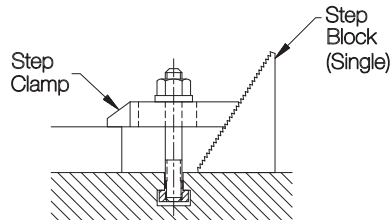

Serrated block that can be used individually or in pairs, as a clamp rest. (One part number consists of a pair of blocks). Use a single block with Step Clamps, or a pair of blocks with Plain Clamps. All blocks and clamps are made from top-grade steel.

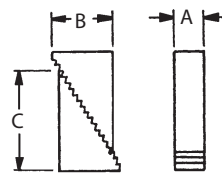

STEP BLOCKS (PAIR)

PART NO.	A	B	C	HEIGHT RANGE
CL-10-BS	1	.681	1.104	3/4 to 1-1/2
CL-20-BS		1.068	1.747	1-1/8 to 2-1/2
CL-30-BS		2.355	3.980	2-1/2 to 6
CL-40-BS	1-1/2	1.454	2.390	1-3/4 to 3-3/4
CL-50-BS		2.355	3.890	2-1/2 to 6
CL-60-BS	2	3.385	5.604	3-1/2 to 9
CL-80-BS		2.355	3.890	2-1/2 to 6
CL-90-BS		3.385	5.604	3-1/2 to 9

7



Step Clamp

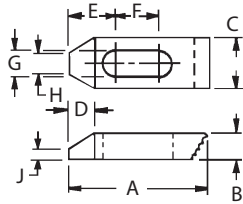

STEP CLAMPS

PART NO.	STUD SIZE	A	B	C	D	E	F	G	H	J	
CL-32-STC	3/8 or M10	2-1/2	1/2	1	7/16	7/8	13/16	7/16	7/16	1/4	
CL-34-STC		4	5/8		11/16	1-3/16	1-5/16		1/4	1/4	
CL-36-STC		6	3/4	1-1/8	3/4	1-1/8	2-3/16	3/8	5/16		
CL-42-STC	1/2 or M12	2-1/2	1/2	1-1/8	7/16	29/32	11/16	9/16	9/16	3/16	
CL-44-STC		4	3/4	1-1/4	11/16	1-7/32	1-3/16		1/2	1/4	
CL-46-STC		6	7/8	3/4	1-5/32	2-1/8	7/16		5/16		
CL-52-STC	5/8 or M16	2-1/2	5/8	1-1/4	3/8	15/16	9/16	11/16	3/4	3/8	
CL-54-STC		4	3/4	1-1/2	11/16	1-1/4	1-1/16		11/16	11/16	3/8
CL-56-STC		6	7/8	3/4	1-9/32	1-15/16	9/16		7/16		
CL-64-STC	3/4 or M20	4	3/4	1-1/2	3/4	1-5/16	15/16	13/16	5/8	5/16	
CL-66-STC		6	1	13/16	1-1/4	1-7/8	1/2		1/2		
CL-68-STC		8		1-3/4	3/4	1-7/8	2-3/16		3/4	5/8	



Plain Clamp

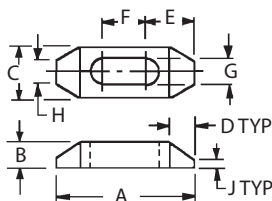

PLAIN CLAMPS

PART NO.	STUD SIZE	A	B	C	D	E	F	G	H	J	
CL-32-PC	3/8 or M10	2-1/2	1/2	1	7/16	27/32	13/16	7/16	7/16	1/4	
CL-34-PC		4	5/8		11/16	1-1/32	1-7/16		1/4	1/4	
CL-36-PC		6	3/4	1-1/8	3/4	1-5/32	2-3/16	3/8	5/16		
CL-42-PC	1/2 or M12	2-1/2	1/2	1-1/8	7/16	29/32	11/16	9/16	9/16	3/16	
CL-44-PC		4	3/4	1-1/4	11/16	1-5/32	1-5/16		1/2	1/4	
CL-46-PC		6	7/8	3/4	1-9/32	2-1/16	7/16		5/16		
CL-52-PC	5/8 or M16	2-1/2	5/8	1-1/4	3/8	31/32	9/16	11/16	3/4	3/8	
CL-54-PC		4	3/4	1-1/2	11/16	1-9/32	1-3/16		11/16	11/16	3/8
CL-56-PC		6	7/8	1-1/2	3/4	1-13/32	1-15/16		9/16	7/16	
CL-64-PC	3/4 or M20	4	3/4	1-1/2	3/4	1-11/32	1-1/16	13/16	5/8	5/16	
CL-66-PC		6	1	13/16	1-15/32	1-15/16	1/2		1/2		
CL-68-PC		8		1-1/8	1-3/4	3/4	1-29/32		2-3/16	3/4	5/8

STEP BLOCKS & CLAMPS

11L17 STEEL, CARBURIZED-HARDENED, BLACK OXIDE FINISH

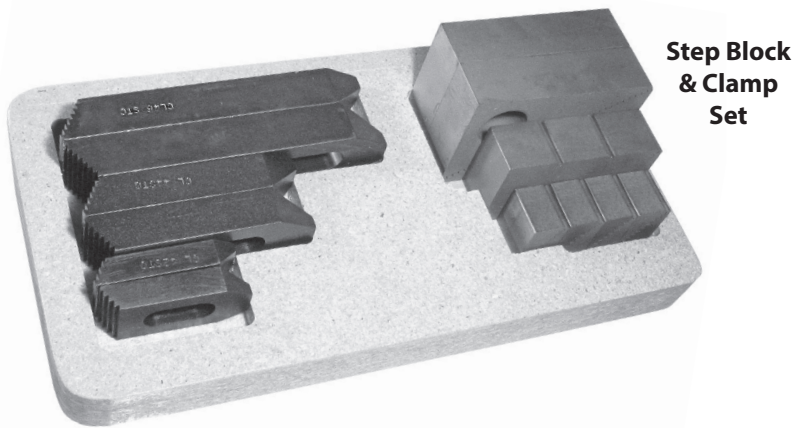

Step Block & Clamp Set

An assortment of Step Clamps and Step Blocks in a handy wooden holder. Available for stud sizes from 3/8-16 to 3/4-10 (M10 to M20 metric studs).

STEP BLOCK & CLAMP SETS

PART NO.	STUD SIZE	STEP CLAMPS (2) EACH		STEP BLOCK PAIRS (2) EACH	HOLDER
CL-10-SBC	3/8-16 or M10	CL-32-STC, CL-34-STC, CL-36-STC	STANDARD	CL-10-BS, CL-20-BS, CL-30-BS	CL-1-BSH
CL-20-SBC	1/2-13 or M12	CL-42-STC, CL-44-STC, CL-46-STC	STANDARD	CL-10-BS, CL-20-BS, CL-30-BS	CL-1-BSH
CL-40-SBC			HIGH-RISE	CL-40-BS, CL-50-BS, CL-60-BS	CL-2-BSH
CL-30-SBC	5/8-11 or M16	CL-52-STC, CL-54-STC, CL-56-STC	STANDARD	CL-10-BS, CL-20-BS, CL-30-BS	CL-1-BSH
CL-50-SBC			HIGH-RISE	CL-40-BS, CL-50-BS, CL-60-BS	CL-2-BSH
CL-60-SBC	3/4-10 or M20	CL-64-STC, CL-66-STC, CL-68-STC	HIGH-RISE	CL-40-BS, CL-50-BS, CL-60-BS	CL-3-BSH

Check Out Our Engineering Resources



Online Trig Book



Request for Quote (RFQ) Information



Technical Information



Fixture Design Principles



Material & Finish Information



Technical Information



Safety



CAD Drawings



carrlane.com/engineering-resources

EDGE CLAMPS

TYPES

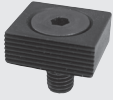

TINY VISE® EDGE CLAMPS

Mini edge clamps grip the side of a workpiece to keep the top clear for machining. Only Tiny Vise® Edge Clamps truly exert down thrust force on the workpiece, to prevent it from lifting. A thrust washer underneath the clamp engages a mating offset countersink to provide downward action.

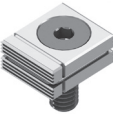

TINY VISE® M-SERIES EDGE CLAMPS

Our Tiny Vise® M-Series incorporates a modular jaw design for greater adjustability. This modular system allows adjusting your workpiece engagement point by adding or removing spacers. This is useful when using the same fixture for machining a family of parts, or when workpiece size can vary somewhat between batches.

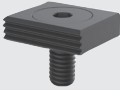

TINY VISE® LOW-PROFILE EDGE CLAMPS

Low-profile Tiny Vise® clamps are ideal for thin workpieces, and whenever downthrust action is not required. These mini edge clamps securely grip the side of a workpiece to keep the top clear for machining. Patented design. Made in USA.

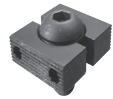

TINY VISE® DOUBLE EDGE CLAMPS

Double edge clamps allow clamping two workpieces at the same time with equal force. These mini edge clamps grip the side of a workpiece to keep the top clear for machining. Patented design provides strong, reliable clamping force with the easy turn of a hex wrench.

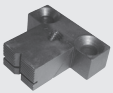

SERRATED EDGE CLAMPS

This low-profile clamp is ideal for gripping the side of a workpiece to keep the top clear for machining. Clamps both forward and down simultaneously, by tightening the socket-head screw in the sliding nose with a hex wrench. V-groove in nose is excellent for clamping round parts of corners.



CAM EDGE CLAMPS

Pivoting-nose edge clamp operated by a cam handle for fast action. Smooth spiral cam locks positively anywhere within its 180 throw. Choice of two sizes. Available with either a standard base for fixed-position mounting, or a slotted base for adjustable mounting.



PIVOTING EDGE CLAMPS

These edge clamps are well suited for holding large castings and other tall workpieces. The pivoting jaw is actuated by a large thrust screw, exerting clamping force forward and downward at the same time. The slotted base provides adjustability.

TINY VISE® EDGE CLAMPS

BODY: 1018 STEEL, CARBURIZED-HARDENED, BLACK OXIDE FINISH
 THRUST WASHER: 1144 STEEL, HEAT TREATED, BLACK OXIDE FINISH
 FLAT-HEAD SOCKET SCREW: STEEL, BLACK OXIDE FINISH



Flat Jaw
 (Reversible, Serrated or Smooth)

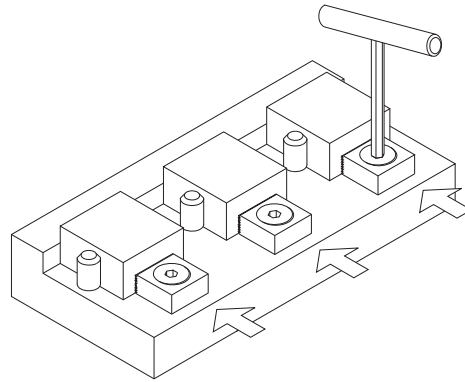

Clamping force is applied by positive screw action with the easy turn of a hex wrench.

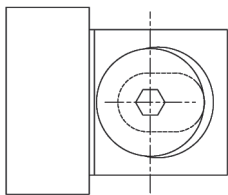

Patented design features a slotted countersink.

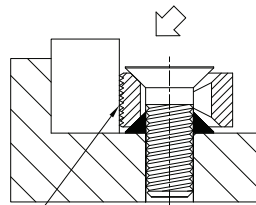

SERRATED JAW

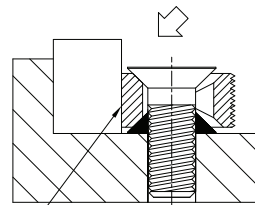

SMOOTH JAW

The serrated face provides maximum gripping, while the smooth face (turn 180°) helps avoid marring finished parts.

Perfect for high-density machining! These mini edge clamps grip the side of a workpiece to keep the top clear for machining. Patented design features a slotted countersink to provide strong, reliable clamping force with the easy turn of a hex wrench. These compact clamps are ideal for fixturing multiple parts, small or large. Each clamp has both a serrated face (for maximum gripping) and a smooth face (to avoid marring finished parts). These clamps look so simple, but work amazingly well, with major advantages over earlier designs. **Patent no. 5,624,106.** Made in USA.

Clamping force is applied by positive screw action with the easy turn of a hex wrench (not with an unreliable, unsafe eccentric cam as used in other designs). A high-strength Flat-Head Socket Screw engages a mating offset countersink to exert strong clamping force. Much more durable than other designs.

Only Tiny Vise® Edge Clamps truly exert down thrust force on the workpiece, to prevent it from lifting. A thrust washer underneath the clamp engages a mating offset countersink to provide downward action.

Available in a wide range of sizes, from a miniature #8-32 thread size, up to a powerful 1"-8 thread size with 2500 lbs clamping force.

Tiny Vise® clamps are designed to provide strong clamping force when tightened by hand. Do not exceed the recommended tightening torque.

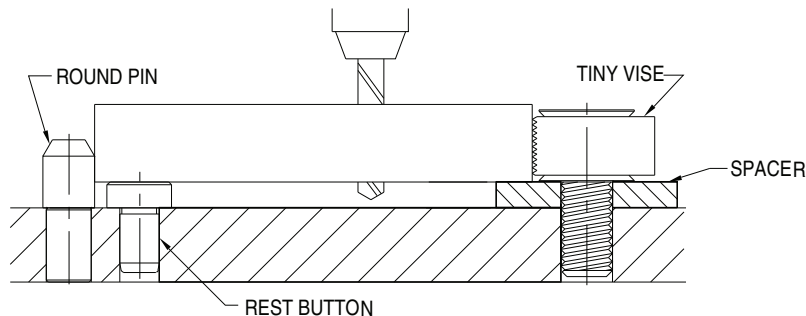

For a small amount of cutting-tool clearance, Tiny Vise® Edge Clamps can be mounted with a spacer underneath, using a longer screw. For greater clearance, clamps should be mounted into a tapped riser block fastened to the plate, to reduce bending stress on the screw.

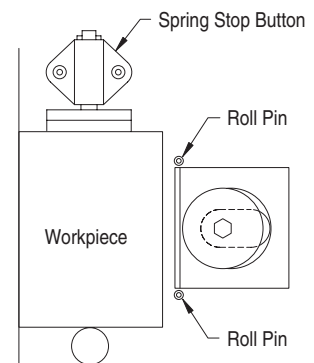

Roll pins can be installed to keep the Tiny Vise® perfectly aligned for workpiece loading (especially helpful on horizontal machining centers).

7

TINY VISE® EDGE CLAMPS

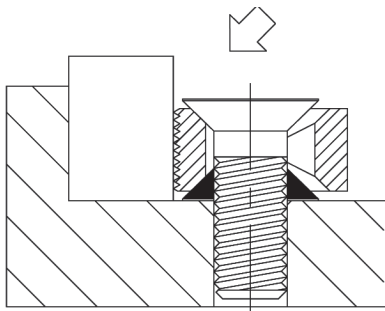

Setup for Downthrust Force
(with Bottom Thrust Washer)

All clamps are supplied with an optional Bottom Thrust Washer (shown in black). Installing this washer under the clamp will raise the clamp slightly and provide downthrust force during clamping.

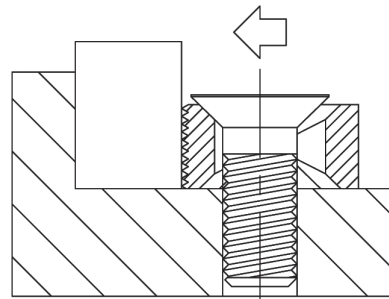

Setup for Horizontal Force
(without Bottom Thrust Washer)

If no downthrust force is required, install the clamp without the Bottom Thrust Washer. Doing so will improve clamping speed because fewer screw turns are required.

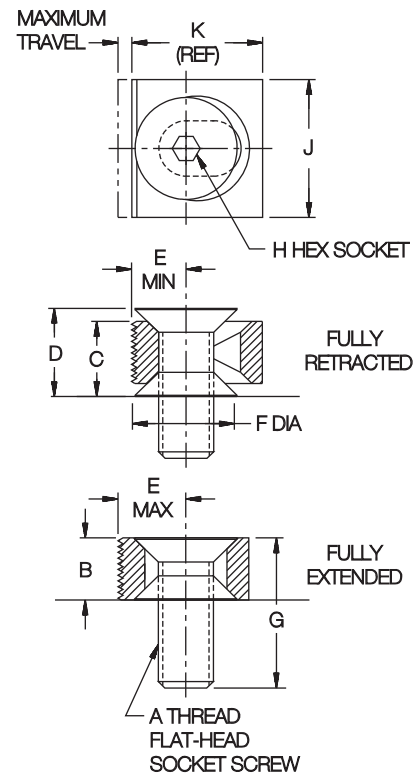

7

FLAT JAW (INCH) SETUP FOR DOWNTHRUST FORCE

PART NO.	A	B	C	D	E			F DIA	G	H	J	K	MAX TRAVEL	RECOMMENDED TORQUE (FT-LBS)*	APPROX. HORIZONTAL CLAMPING FORCE AT RECOMMENDED TORQUE (LBS)*
					MIN	MID RANGE	MAX								
CL-2-TV	#8-32	.250	.319	.382	.175	.205	.235	.335	5/8	3/32	9/16	.470	.060	.20	60
CL-3-TV	#10-32	.312	.390	.459	.208	.242	.274	.390	3/4	1/8	5/8	.550	.066	.25	75
CL-4-TV	1/4-20	.375	.467	.552	.280	.320	.360	.510	7/8	5/32	7/8	.720	.080	.50	130
CL-5-TV	5/16-18	.438	.550	.652	.338	.386	.434	.640	1	3/16	1	.870	.096	1.2	240
CL-6-TV	3/8-16	.500	.627	.746	.390	.445	.500	.742	1-1/8	7/32	1-1/8	1.000	.110	2.3	370
CL-8-TV	1/2-13	.562	.702	.833	.474	.534	.594	.897	1-3/8	5/16	1-1/4	1.187	.120	6.6	800
CL-10-TV	5/8-11	.750	.901	1.039	.620	.685	.750	1.148	1-5/8	3/8	1-5/8	1.500	.130	12	1,200
CL-12-TV	3/4-10	.875	1.059	1.234	.740	.820	.900	1.394	2	1/2	2	1.800	.160	23	1,800
CL-16-TV	1"-8	1.125	1.355	1.573	.988	1.088	1.188	1.890	2-1/2	5/8	2-1/2	2.375	.200	42	2,500

FLAT JAW (INCH) SETUP FOR HORIZONTAL FORCE

CL-2-TV	#8-32	.250	.250	.313	.175	.205	.235	.335	5/8	3/32	9/16	.470	.060	.40	60
CL-3-TV	#10-32	.312	.312	.381	.208	.242	.274	.390	3/4	1/8	5/8	.550	.066	.50	75
CL-4-TV	1/4-20	.375	.375	.460	.280	.320	.360	.510	7/8	5/32	7/8	.720	.080	1.0	130
CL-5-TV	5/16-18	.438	.438	.540	.338	.386	.434	.640	1	3/16	1	.870	.096	2.4	240
CL-6-TV	3/8-16	.500	.500	.619	.390	.445	.500	.742	1-1/8	7/32	1-1/8	1.000	.110	4.6	370
CL-8-TV	1/2-13	.562	.652	.693	.474	.534	.594	.897	1-3/8	5/16	1-1/4	1.187	.120	13	800
CL-10-TV	5/8-11	.750	.750	.888	.620	.685	.750	1.148	1-5/8	3/8	1-5/8	1.500	.130	24	1,200
CL-12-TV	3/4-10	.875	.875	1.050	.740	.820	.900	1.394	2	1/2	2	1.800	.160	46	1,800
CL-16-TV	1"-8	1.125	1.125	1.343	.988	1.088	1.188	1.890	2-1/2	5/8	2-1/2	2.375	.200	84	2,500

*Recommended torque and clamping force are at 1/3 of yield strength, leaving 2/3 of holding capacity to resist external cutting forces, etc.

TINY VISE® EDGE CLAMPS

BODY: 1018 STEEL, CARBURIZED-HARDENED, BLACK OXIDE FINISH
 THRUST WASHER: 1144 STEEL, HEAT TREATED, BLACK OXIDE FINISH
 FLAT-HEAD SOCKET SCREW: STEEL, BLACK OXIDE FINISH

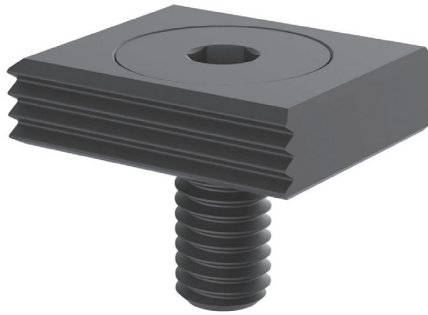

Low Profile

(Reversible — Serrated or Smooth Jaw)

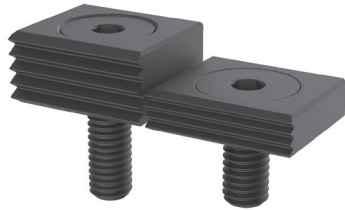

Compare the amazing low-profile Tiny Vise® clamp (right) with our standard Tiny Vise® clamp (left).

These low-profile clamps are ideal for thin workpieces, and whenever downthrust action is not required.

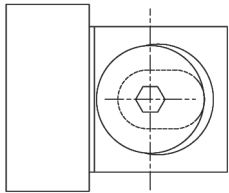
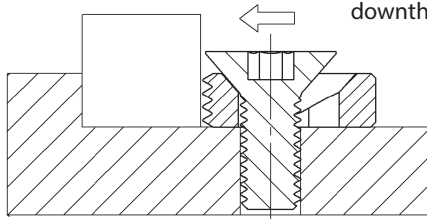

Patented design features a slotted countersink.

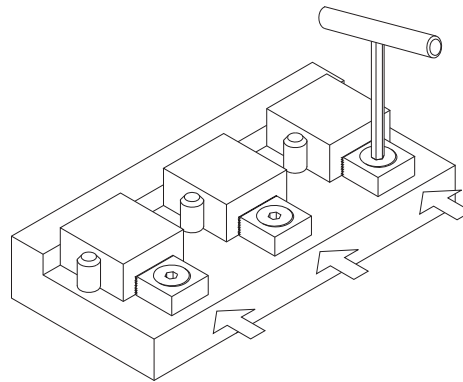

Clamping force is applied by positive screw action with the easy turn of a hex wrench.

Low-Profile Version!

Low-profile Tiny Vise® clamps are ideal for thin workpieces, and whenever downthrust action is not required. These mini edge clamps securely grip the side of a workpiece to keep the top clear for machining. Patented design features a slotted countersink to provide strong, reliable clamping force with the easy turn of a hex wrench. These compact clamps are ideal for fixturing multiple parts, small or large. Each clamp has both a serrated face (for maximum gripping) and a smooth face (to avoid marring finished parts). These clamps look so simple, but work amazingly well, with major advantages over earlier designs. **Patent no. 5,624,106.** Made in USA.

Clamping force is applied by positive screw action with the easy turn of a hex wrench (not with an unreliable, unsafe eccentric cam as used in other designs). A high-strength Flat-Head Socket Screw engages a mating slotted countersink to exert strong clamping force. Much more durable than other designs.

Available in a wide range of sizes, from a miniature #8-32 thread size, up to a powerful 1"-8 thread size with 2500 lbs clamping force. Tiny Vise® clamps are designed to provide strong clamping force when tightened by hand. Do not exceed the recommended tightening torque.

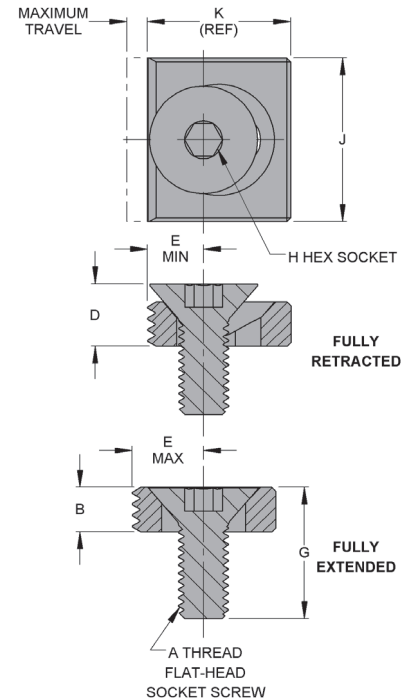

LOW PROFILE (INCH)

PART NO.	A	B	D	E			G	H	J	K	MAX TRAVEL	RECOMMENDED TORQUE (FT-LBS)*	APPROX. HORIZONTAL CLAMPING FORCE AT RECOMMENDED TORQUE (LBS)*
				MIN	MID RANGE	MAX							
CL-2-TVLP	#8-32	.150	.213	.175	.205	.235	1/2	3/32	9/16	.470	.060	.40	60
CL-3-TVLP	#10-32	.200	.269	.208	.242	.274	5/8	1/8	5/8	.550	.066	.50	75
CL-4-TVLP	1/4-20	.225	.310	.280	.320	.360	3/4	5/32	7/8	.720	.080	1.0	130
CL-5-TVLP	5/16-18	.250	.352	.338	.386	.434	7/8	3/16	1	.870	.096	2.4	240
CL-6-TVLP	3/8-16	.300	.419	.390	.445	.500	1	7/32	1-1/8	1.000	.110	4.6	370
CL-8-TVLP	1/2-13	.325	.456	.474	.534	.594	1-1/4	5/16	1-1/4	1.187	.120	13	800
CL-10-TVLP	5/8-11	.425	.563	.620	.685	.750	1-1/2	3/8	1-5/8	1.500	.130	24	1,200
CL-12-TVLP	3/4-10	.500	.675	.740	.820	.900	1-3/4	1/2	2	1.800	.160	46	1,800
CL-16-TVLP	1"-8	.750	.968	.988	1.088	1.188	2	5/8	2-1/2	2.375	.200	84	2,500

*Recommended torque and clamping force are at 1/3 of yield strength, leaving 2/3 of holding capacity to resist external cutting forces, etc.



Ideal for Tall Workpieces or Castings

Pivoting Edge Clamps

Easy conversion to hydraulic operation!

CarrLane[®]
M A N U F A C T U R I N G C O .

TINY VISE® EDGE CLAMPS

BODY: 1018 STEEL, CARBURIZED-HARDENED, BLACK OXIDE FINISH
 JAW: 1018 STEEL, CARBURIZED-HARDENED, BLACK OXIDE FINISH (OR DELRIN)
 THRUST WASHER: 1144 STEEL, HEAT TREATED, BLACK OXIDE FINISH
 FLAT-HEAD SOCKET SCREW: STEEL, BLACK OXIDE FINISH



Modular Jaw

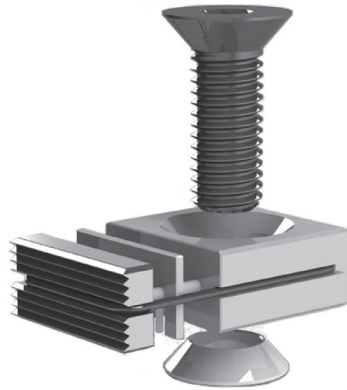

Modular jaw design allows adjustment for workpiece-size variations.

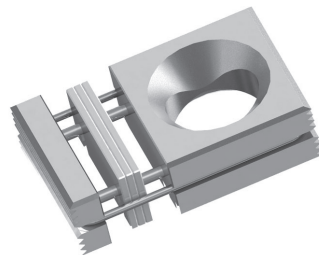
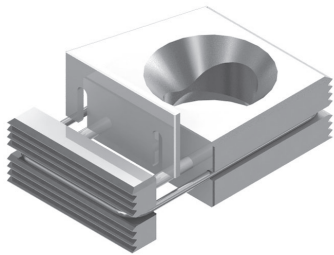

These M-series clamps have a 1/4"-thick modular jaw that can be easily extended to insert or remove spacers. Up to three 1/16" spacers can be inserted to provide adjustment.

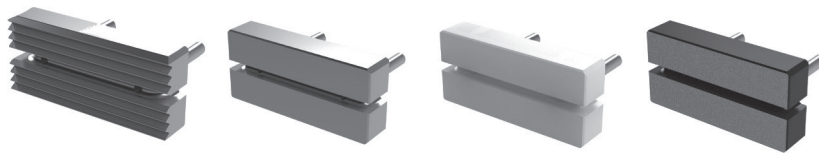

Serrated

Smooth

**Smooth
(Delrin®)**

**Carbide
Abrasive**

Choice of four modular jaw faces: 1) Serrated hardened steel, for maximum gripping bite; 2) Smooth hardened steel, to avoid marring on finished surfaces; 3) Smooth Delrin®, to further protect finished surfaces when less clamping force is required; 4) Carbide-abrasive-coated steel, for strong gripping with minimal surface penetration. Any of the four jaws can be mounted on the same body.

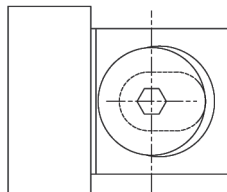

Patented design features a slotted countersink.

Available with a choice of jaw faces, including carbide abrasive!

Our Tiny Vise® M-series incorporates a modular jaw design for greater adjustability. This new modular system allows adjusting your workpiece engagement point by adding or removing spacers. This is useful when using the same fixture for machining a family of parts, or when workpiece size can vary somewhat between batches. Just like our original Tiny Vise®, these mini edge clamps grip the side of a workpiece to keep the top clear for machining. The patented design features a slotted countersink to provide strong, reliable clamping force with the easy turn of a hex wrench. These compact clamps are ideal for fixturing multiple parts, small or large. They look so simple, but work amazingly well! **Patent No. 10,179,393 B2.** Made in USA.

The M-series clamp body, without a jaw, is the same size as a standard Tiny Vise®— with the same reversible jaw faces (one serrated and one smooth). The 1/4"-thick serrated modular jaw mounts into the smooth face, and each spacer adds another 1/16". Up to three spacers can be inserted to provide adjustment. The modular jaw assembly is held together securely by a tough, durable O-ring, recessed in a protective groove. The modular jaw can be easily extended to insert or remove the slotted spacers.

Clamping force is applied by positive screw action with the easy turn of a hex wrench (not with an unreliable, unsafe eccentric cam as used in other designs). A high-strength Flat-Head Socket Screw engages a mating offset countersink to exert strong clamping force. Much more durable than other designs.

Clamps can be set up to apply force either at a downward angle or straight horizontally. All clamps are supplied with an optional bottom thrust washer. Installing this washer under the clamp will raise the clamp slightly and provide downthrust force during clamping. If no downthrust force is required, install the clamp without the bottom thrust washer. Doing so will improve clamping speed because fewer screw turns are required.

Available in two sizes, 5/16-18 thread size (240 lbs clamping force) and 1/2-13 thread size (800 lbs clamping force). Tiny Vise® clamps are designed to provide strong clamping force when tightened by hand. Do not exceed the recommended tightening torque.

7

TINY VISE® EDGE CLAMPS

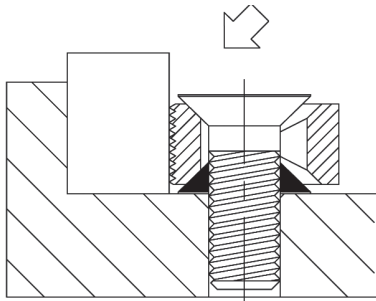

Setup for Downthrust Force
(with Bottom Thrust Washer)

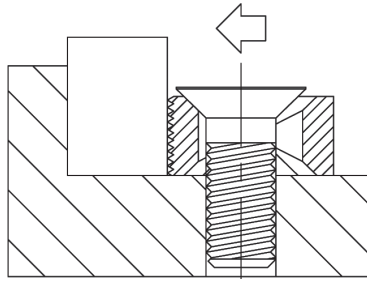

Setup for Horizontal Force
(without Bottom Thrust Washer)

All clamps are supplied with an optional Bottom Thrust Washer (shown in black). Installing this washer under the clamp will raise the clamp slightly and provide downthrust force during clamping.

If no downthrust force is required, install the clamp without the Bottom Thrust Washer. Doing so will improve clamping speed because fewer screw turns are required.

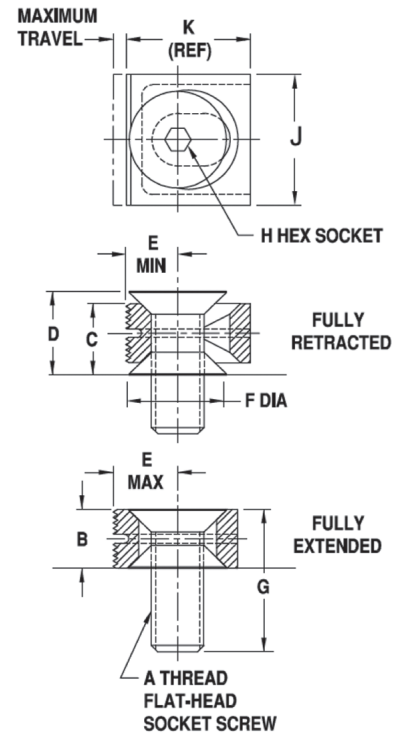
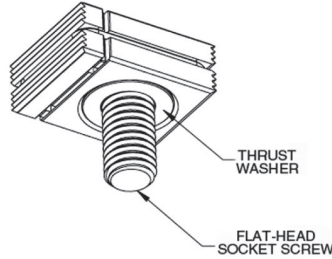
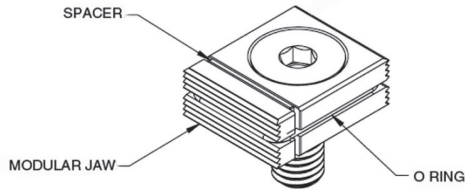

MODULAR JAW (INCH) SETUP FOR DOWNTHRUST FORCE

PART NO.	JAW TYPE	A	B	C	D	E			F DIA	G	H	J	K	MAX TRAVEL	RECOMMENDED TORQUE (FT-LBS)*	APPROX. HORIZONTAL CLAMPING FORCE AT RECOMMENDED TORQUE (LBS)*
						MIN	MID RANGE	MAX								
CL-5-TVM	Serrated	5/16-18	.438	.550	.652	.338	.386	.434	.640	1	3/16	1	.870	.096	1.2	240
CL-5-TVMS	Smooth															
CL-5-TVMN	Smooth (Delrin®)															
CL-5-TVMC	Carbide Abrasive															
CL-8-TVM	Serrated	1/2-13	.562	.702	.833	.474	.534	.594	.897	1-3/8	5/16	1-1/4	1.187	.120	6.6	800
CL-8-TVMS	Smooth															
CL-8-TVMN	Smooth (Delrin®)															
CL-8-TVMC	Carbide Abrasive															

MODULAR JAW (INCH) SETUP FOR HORIZONTAL FORCE

CL-5-TVM	Serrated	5/16-18	.438	.438	.540	.338	.386	.434	.640	1	3/16	1	.870	.096	2.4	240
CL-5-TVMS	Smooth															
CL-5-TVMN	Smooth (Delrin®)															
CL-5-TVMC	Carbide Abrasive															
CL-8-TVM	Serrated	1/2-13	.562	.652	.693	.474	.534	.594	.897	1-3/8	5/16	1-1/4	1.187	.120	13	800
CL-8-TVMS	Smooth															
CL-8-TVMN	Smooth (Delrin®)															
CL-8-TVMC	Carbide Abrasive															

*Recommended torque and clamping force are at 1/3 of yield strength, leaving 2/3 of holding capacity to resist external cutting forces, etc.

SPARE PARTS

COMPLETE CLAMP PART NO.	MODULAR JAW				SPACER	O RING	THRUST WASHER	FLAT-HEAD SOCKET SCREW
	SERRATED	SMOOTH	SMOOTH (DELIN®)	CARBIDE ABRASIVE				
CL-5-TVM	5-TVM-JAW-ASSY	5-TVMS-JAW-ASSY	5-TVMN-JAW-ASSY	5-TVMC-JAW-ASSY	5-TVM-SPAC	5-TVM-ORING	CL-5-TV-WASH	CL-5/16-18X1.00-FHSS
CL-8-TVM	8-TVM-JAW-ASSY	8-TVMS-JAW-ASSY	8-TVMN-JAW-ASSY	8-TVMC-JAW-ASSY	8-TVM-SPAC	8-TVM-ORING	CL-8-TV-WASH	CL-1/2-13X1.38-FHSS

TINY VISE® DOUBLE EDGE CLAMPS

BODY: 1018 STEEL, CARBURIZED-HARDENED, BLACK OXIDE FINISH. SPRINGS: 302 STAINLESS STEEL
GUIDE PINS: 17 4-PH STAINLESS STEEL. THRUST WASHER: 1144 STEEL, HEAT TREATED, BLACK OXIDE FINISH
SOCKET-HEAD CAP SCREW: STEEL, BLACK OXIDE FINISH

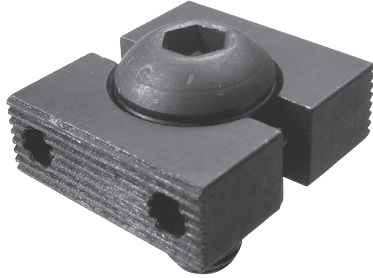

Two Serrated Flat Jaws

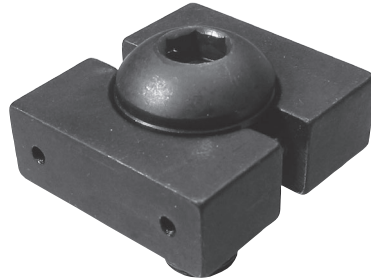

Two Smooth Flat Jaws

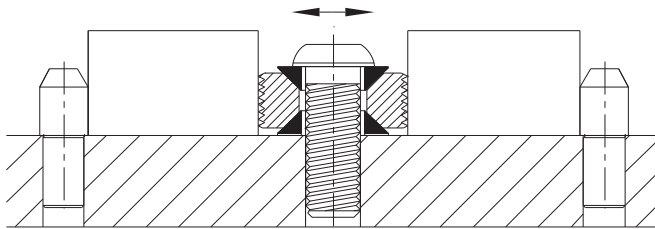

Thrust Washers have ID clearance to enable them to float horizontally, allowing both clamping jaws to contact their workpiece simultaneously even if parts are slightly different in size. This ensures that both parts are securely clamped with equal force.

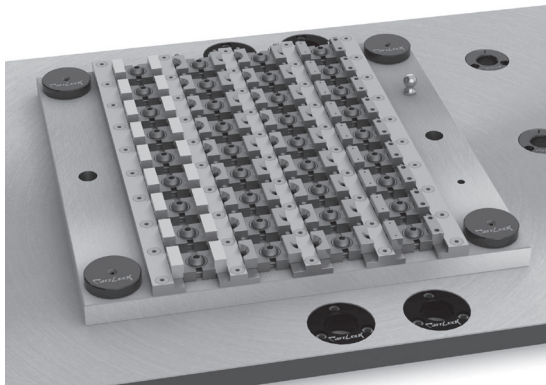

Tiny Vise® Edge Clamps are ideal for high-density machining. This quick-change Carr Lock® fixture holds 72 parts using 36 Double Edge Clamps.

Double edge clamps allow clamping two workpieces at the same time with equal force. These mini edge clamps grip the side of a workpiece to keep the top clear for machining. Patented design provides strong, reliable clamping force with the easy turn of a hex wrench. These compact clamps are ideal for fixturing multiple parts, small or large. Available with serrated jaws (for maximum gripping) or smooth jaws (to avoid marring finished parts). These clamps look so simple, but work amazingly well, with major advantages over earlier designs. **Patent no. 5,961,108.** Made in USA.

Clamping force is applied by positive screw action with the easy turn of a hex wrench (not with an unreliable, unsafe eccentric cam as used in other designs). A high-strength cap screw and Thrust Washer engage a mating offset countersink to exert strong clamping force. Much more durable than other designs.

Only Tiny Vise® Mini Edge Clamps truly exert down thrust force on the workpiece, to prevent it from lifting. A Thrust Washer underneath the clamp engages a mating offset countersink to provide downward action.

Only Tiny Vise® Double Edge Clamps compensate for size variation when clamping two workpieces. Thrust Washers have ID clearance to enable them to float horizontally, allowing both clamping jaws to contact their part simultaneously. This ensures that both parts are securely clamped with equal force.

Available in four sizes, from 5/16-18 up to a powerful 1"-8 thread size with 4500 lbs clamping force (M8 to M24 in metric).

Please note: Tiny Vise® clamps are designed to provide strong clamping force when tightened by hand. Do not exceed the recommended tightening torque. Double edge clamps should always be used to hold two workpieces, not just one; otherwise recommended torque and clamping force will be significantly reduced.

TINY VISE® DOUBLE EDGE CLAMPS

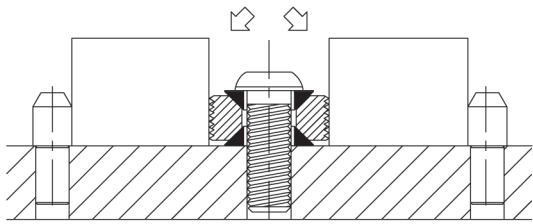

Setup for Downthrust Force
(with Bottom Thrust Washer)

All clamps are supplied with two Thrust Washers (shown in black). The Bottom Thrust Washer is optional. Installing this washer will raise the clamp slightly and provide downthrust force during clamping.

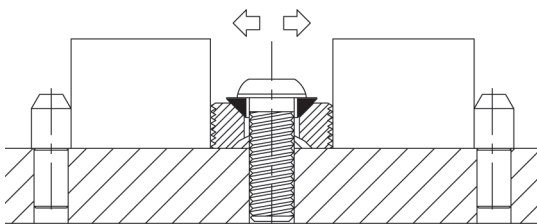

Setup for Horizontal Force
(without Bottom Thrust Washer)

If no downthrust force is required, install the clamp without the Bottom Thrust Washer. Doing so will improve clamping speed because fewer screw turns are required.

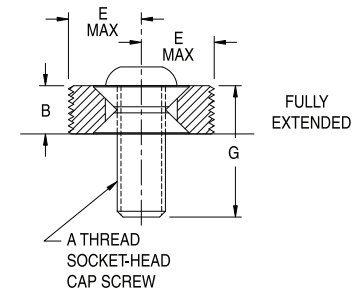
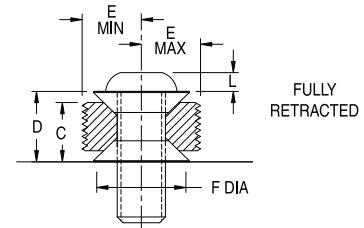
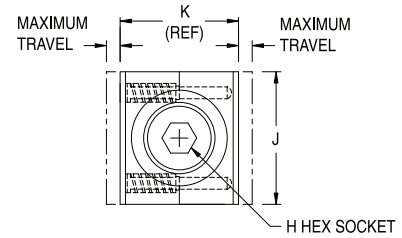

DOUBLE FLAT JAWS (INCH) — SETUP FOR DOWNTHRUST FORCE

PART NO. SERRATED JAWS	PART NO. SMOOTH JAWS	A	B	C	D	E			F DIA	G	H	J	K	L	ALLOWABLE WORKPIECE SIZE DIFFERENTIAL	MAXIMUM TRAVEL (WITH NO SIZE DIFFERENTIAL)	RECOMMENDED TORQUE (FT-LBS)*	APPROX. HORIZONTAL CLAMPING FORCE AT RECOMMENDED TORQUE (LBS)*
						MIN	MID RANGE	MAX										
CL-50-TV	CL-55-TV	5/16-18	.375	.486	.597	.422	.470	.518	.625	1	3/16	1	.844	.16	.048	.096	4.5	450
CL-60-TV	CL-65-TV	3/8-16	.438	.570	.684	.520	.572	.625	.750	1-1/8	7/32	1-1/4	1.250	.19	.052	.105	8	650
CL-80-TV	CL-85-TV	1/2-13	.500	.635	.770	.641	.698	.755	.875	1-1/4	5/16	1-3/8	1.282	.26	.060	.114	19	1200
CL-100-TV	CL-105-TV	5/8-11	.625	.765	.905	.690	.750	.810	1.125	1-1/2	3/8	1-1/2	1.380	.32	.078	.120	38	1800
CL-160-TV	CL-165-TV	1"-8	1.000	1.159	1.318	1.109	1.178	1.247	1.875	2-1/4	3/4	2-1/2	2.218	1.00	.094	.138	150	4500

DOUBLE FLAT JAWS (INCH) — SETUP FOR HORIZONTAL FORCE

CL-50-TV	CL-55-TV	5/16-18	.375	.375	.486	.422	.470	.518	.625	1	3/16	1	.844	.16	.048	.096	9	450
CL-60-TV	CL-65-TV	3/8-16	.438	.438	.552	.520	.572	.625	.750	1-1/8	7/32	1-1/4	1.250	.19	.052	.105	16	650
CL-80-TV	CL-85-TV	1/2-13	.500	.500	.635	.641	.698	.755	.875	1-1/4	5/16	1-3/8	1.282	.26	.060	.114	38	1200
CL-100-TV	CL-105-TV	5/8-11	.625	.625	.765	.690	.750	.810	1.125	1-1/2	3/8	1-1/2	1.380	.32	.078	.120	76	1800
CL-160-TV	CL-165-TV	1"-8	1.000	1.000	1.159	1.109	1.178	1.247	1.875	2-1/4	3/4	2-1/2	2.218	1.00	.094	.138	300	4500

DOUBLE FLAT JAWS (METRIC) — SETUP FOR DOWNTHRUST FORCE

PART NO.	A THREAD	THREAD PITCH (mm)	B (mm)	C (mm)	D (mm)	E MIN (mm)	E MID RANGE (mm)	E MAX (mm)	F DIA (mm)	G (mm)	H (mm)	J (mm)	K (mm)	L (mm)	ALLOWABLE WORKPIECE SIZE DIFFERENTIAL (mm)	MAXIMUM TRAVEL (WITH NO SIZE DIFFERENTIAL) (mm)	RECOMMENDED TORQUE (Nm)	APPROX. HORIZONTAL CLAMPING FORCE AT RECOMMENDED TORQUE (N)
CLM-50-TV	M8	1.25	9.5	12.3	15.2	10.7	11.9	13.1	16.5	30	5	25.5	21.5	4	1.2	2.4	6.1	2000
CLM-60-TV	M10	1.5	11.1	14.5	17.5	13.2	14.5	15.8	19	30	6	32	26.5	5	1.3	2.7	14	3300
CLM-80-TV	M12	1.75	12.7	16	19.5	16.3	17.7	19.1	23	30	8	35	32.5	6.5	1.5	2.8	24	4900
CLM-100-TV	M16	2	16	19.5	23	17.5	19	20.5	29	40	10	38	35	8	2	3	57	8900
CLM-160-TV	M24	3	25.5	29.5	33.5	28.2	29.9	31.6	47.5	50	19	63.5	56.5	24	2.4	3.4	180	18000

DOUBLE FLAT JAWS (METRIC) — SETUP FOR HORIZONTAL FORCE

CLM-50-TV	M8	1.25	9.5	12.3	15.2	10.7	11.9	13.1	16.5	30	5	25.5	21.5	4	1.2	2.4	12	2000
CLM-60-TV	M10	1.5	11.1	14.5	17.5	13.2	14.5	15.8	19	30	6	32	26.5	5	1.3	2.7	27	3300
CLM-80-TV	M12	1.75	12.7	16	19.5	16.3	17.7	19.1	23	30	8	35	32.5	6.5	1.5	2.8	47	4900
CLM-100-TV	M16	2	16	19.5	23	17.5	19	20.5	29	40	10	38	35	8	2	3	110	8900
CLM-160-TV	M24	3	25.5	29.5	33.5	28.2	29.9	31.6	47.5	50	19	63.5	56.5	24	2.4	3.4	350	18000

*Recommended torque and clamping force are at 1/3 of yield strength, leaving 2/3 of holding capacity to resist external cutting forces, etc.

Go Lean With
CarrLock[®]
System

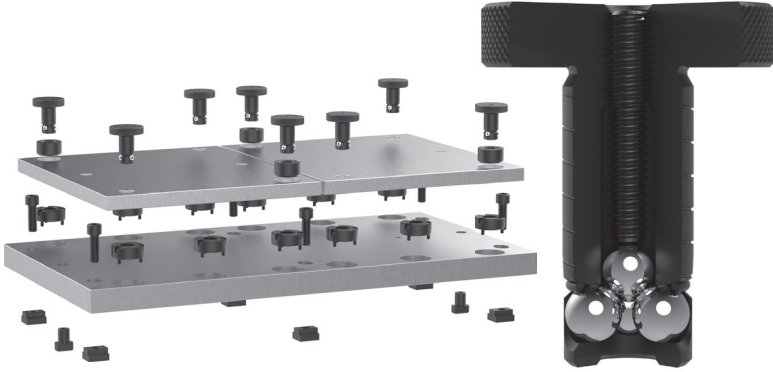

Change from job
to job in seconds



7

Our Customer Service team is here to help



Ordering
Information

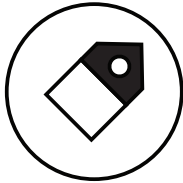

Price &
Availability



Request
A Quote



cs@carrlane.com
314.647.6200

CAM EDGE CLAMPS

BODY: STEEL, WEAR SURFACES HARDENED, BLACK OXIDE FINISH
BALL HANDLE: BLACK PHENOLIC PLASTIC

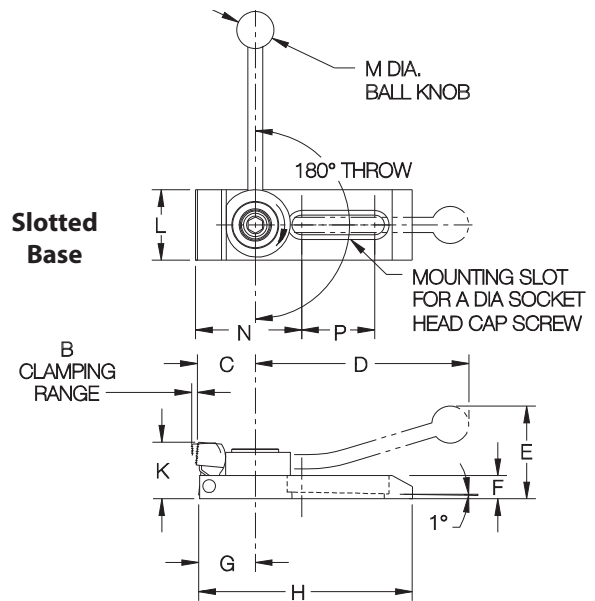
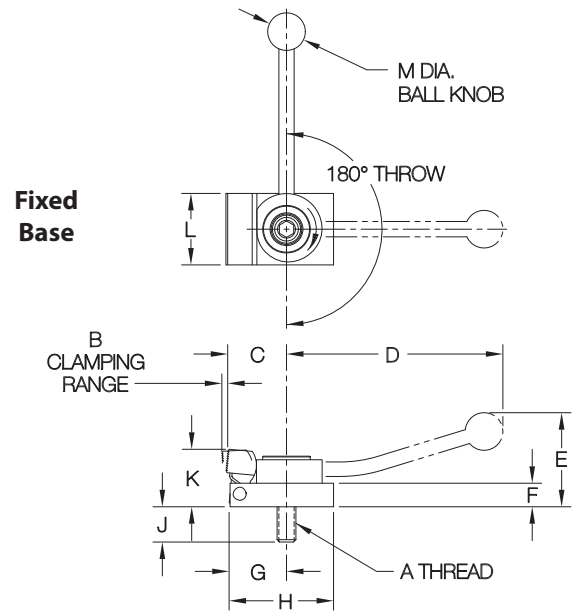
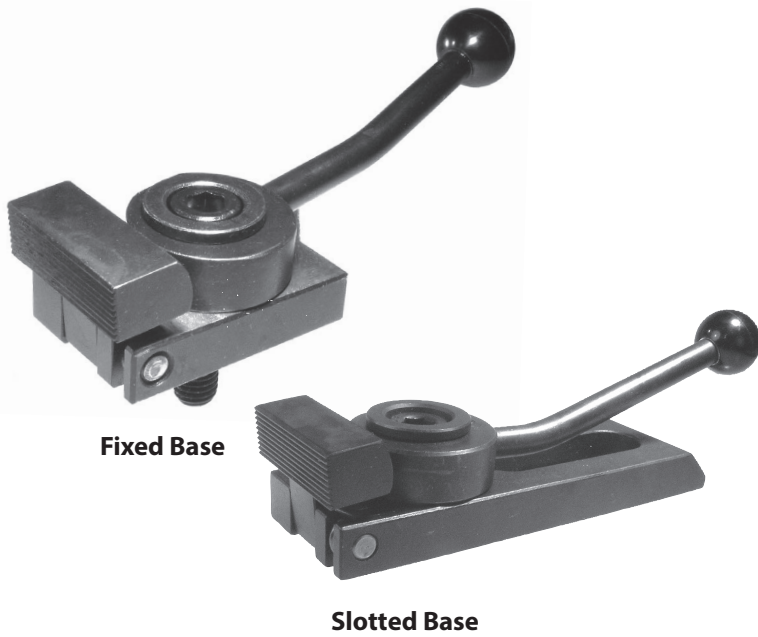

Pivoting-nose edge clamp operated by a cam handle for fast action. Smooth spiral cam locks positively anywhere within its 180° throw. Choice of two sizes. Available with either a standard base for fixed-position mounting, or a slotted base for adjustable mounting. Choice of clockwise or counterclockwise handle rotation to clamp.

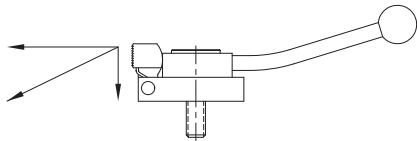

Nose pivots to exert clamping force forward and downward at the same time.

FIXED BASE (INCH)

PART NO.												K		MAX CLAMPING FORCE (LBS)				
CLOCKWISE CLAMPING	CCW CLAMPING	A	B	C	D	E	F	G	H	J	MIN	MAX	L	M	N	P	HORIZONTAL	VERTICAL
CL-MF25-5601	CL-MF25-5602	5/16-18	5/32	1-1/8	3-15/16	1-5/8	7/16	15/16	1-3/4	11/16	7/8	1	1-1/4	3/4	—	—	750	50
CL-MF40-5601		1/2-13	7/32	1-9/16	5-3/4	2-1/2	5/8	1-1/2	2-3/4	15/16	1-5/16	1-1/2	1-7/8	1	—	—	1500	100

FIXED BASE (METRIC)

CL-MF12-5602	—	M12	7/32	1-9/16	5-3/4	2-1/2	5/8	1-1/2	2-3/4	.47	1-5/16	1-1/2	1-7/8	1	—	—	1500	100
--------------	---	-----	------	--------	-------	-------	-----	-------	-------	-----	--------	-------	-------	---	---	---	------	-----

SLOTTED BASE

CL-MF25-5611	—	5/16-18 or M8	5/32	1-1/8	3-15/16	1-5/8	7/16	15/16	3-1/2	—	7/8	1	1-1/4	3/4	2	1	750	50
CL-MF40-5611	—	1/2-13 or M12	7/32	1-9/16	5-3/4	2-1/2	5/8	1-1/2	6	—	1-5/16	1-1/2	1-7/8	1	2-15/16	2	1500	100

SERRATED EDGE CLAMPS

BODY AND NOSE: 1018 STEEL, CARBURIZED-HARDENED, BLACK OXIDE FINISH
 CLAMPING SCREW: 4140 STEEL, HEAT TREATED RC 43-45, BLACK OXIDE FINISH
 NOSE COVER: ALUMINUM

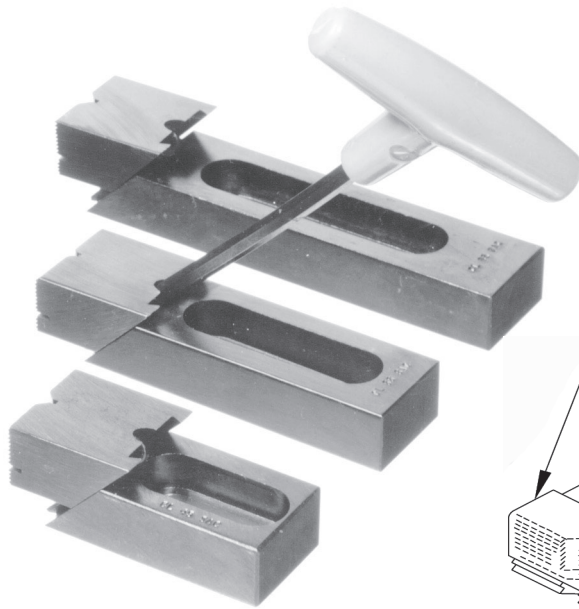

Serrated Adjustable Edge Clamp (High Nose)

Removable aluminum nose cover, furnished on high-nose version

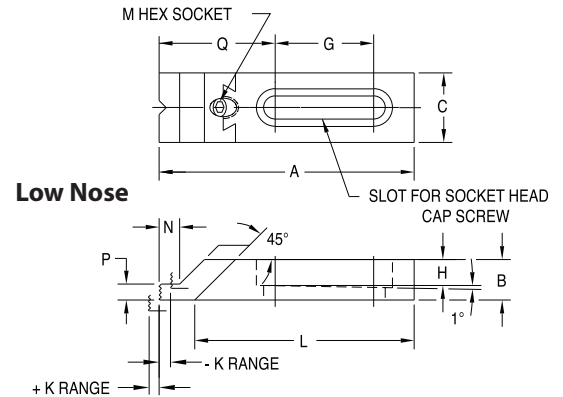
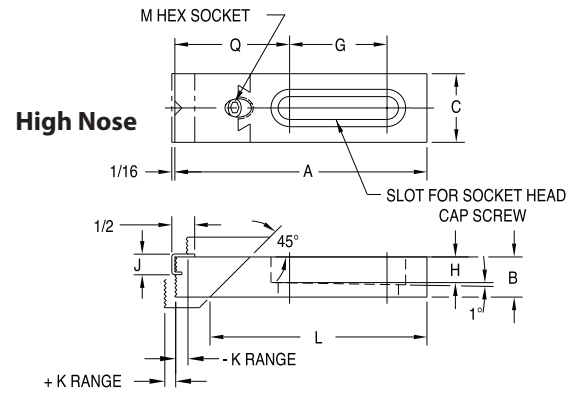

This low-profile clamp is ideal for gripping the side of a workpiece to keep the top clear for machining. Clamps both forward and down simultaneously, by tightening the socket-head screw in the sliding nose with a hex wrench. V-groove in nose is excellent for clamping round parts or corners. Choice of five sizes, each available in several slot lengths. Slot is tapered to prevent the clamp from backing off under heavy forces. Use two mounting screws on longer clamps.

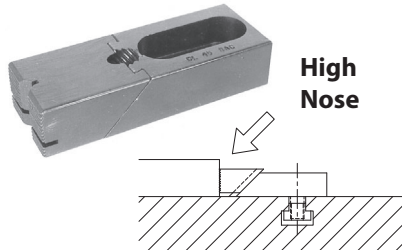

High Nose

High-nose version is best for most applications. Gripping high up on the workpiece, close to the machining plane, provides maximum clamping rigidity. A removable aluminum nose cover is furnished for clamping soft or machined parts without damage.

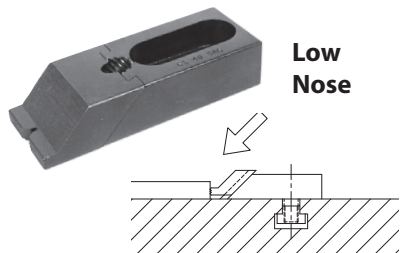

Low Nose

Low-nose version is ideal for thin parts, with its extra machining clearance.

ADJUSTABLE — HIGH NOSE

PART NO.	MOUNTING SCREW SIZE	A	B	C	G	H	J	K	L	M	N	P	Q
CL-1-SAC		2	5/8	1	1/4	9/32	7/16	1/4	1-1/2	5/32	—	—	1-3/8
CL-5-SAC	5/16-18 or M8	3	5/8	1	1-1/4	9/32	7/16	1/4	2-1/2	5/32	—	—	1-11/16
CL-15-SAC		3	5/8	1-1/4	13/16	3/8	7/16	1/4	2-3/8	3/16	—	—	2-1/16
CL-25-SAC	3/8-16 or M10	4-1/4	5/8	1-1/4	1-7/16	3/8	7/16	1/4	3-5/8	3/16	—	—	1-7/8
CL-35-SAC		5	5/8	1-1/4	2-1/8	3/8	7/16	1/4	4-3/8	3/16	—	—	2-1/4
CL-45-SAC		4	7/8	1-1/2	1-1/4	1/2	5/8	5/16	3-3/16	1/4	—	—	2-1/2
CL-55-SAC	1/2-13 or M12	5-1/2	7/8	1-1/2	2-1/8	1/2	5/8	5/16	4-11/16	1/4	—	—	2-9/16
CL-65-SAC		7-1/8	7/8	1-1/2	3	1/2	5/8	5/16	6-5/16	1/4	—	—	3-9/32
CL-75-SAC		5-1/2	1-1/4	1-3/4	1-3/8	5/8	3/4	5/16	4-1/2	5/16	—	—	3
CL-95-SAC	5/8-11 or M16	8-1/4	1-1/4	1-3/4	4	5/8	3/4	5/16	7-1/4	5/16	—	—	3-9/32
CL-105-SAC		5-1/2	1-1/4	1-3/4	1-3/8	3/4	3/4	5/16	4-1/2	5/16	—	—	3
CL-125-SAC	3/4-10 or M20	8-1/4	1-1/4	1-3/4	4	3/4	3/4	5/16	7-1/4	5/16	—	—	3

ADJUSTABLE — LOW NOSE

PART NO.	MOUNTING SCREW SIZE	A	B	C	G	H	J	K	L	M	N	P	Q
CL-0-SAC		2	5/8	1	1/4	9/32	—	1/4	1-1/2	5/32	1/8	1/8	1-3/8
CL-00-SAC	5/16-18 or M8	3	5/8	1	1-1/4	9/32	—	1/4	2-1/2	5/32	1/8	1/8	1-3/8
CL-10-SAC		3	5/8	1-1/4	13/16	3/8	—	1/4	2-3/8	3/16	1/4	1/4	1-11/16
CL-20-SAC	3/8-16 or M10	4-1/4	5/8	1-1/4	1-7/16	3/8	—	1/4	3-5/8	3/16	1/4	1/4	2-1/16
CL-30-SAC		5	5/8	1-1/4	2-1/8	3/8	—	1/4	4-3/8	3/16	1/4	1/4	1-7/8
CL-40-SAC		4	7/8	1-1/2	1-1/4	1/2	—	1/4	3-3/16	3/16	1/4	1/4	2-1/4
CL-50-SAC	1/2-13 or M12	5-1/2	7/8	1-1/2	2-1/8	1/2	—	1/4	4-11/16	3/16	1/4	1/4	2-1/2
CL-60-SAC		7-1/8	7/8	1-1/2	3	1/2	—	1/4	6-5/16	3/16	1/4	1/4	2-9/16
CL-70-SAC		5-1/2	1-1/4	1-3/4	1-3/8	5/8	—	1/4	4-1/2	5/16	5/16	3/8	3-9/32
CL-90-SAC	5/8-11 or M16	8-1/4	1-1/4	1-3/4	4	5/8	—	1/4	7-1/4	5/16	5/16	3/8	3
CL-100-SAC		5-1/2	1-1/4	1-3/4	1-3/8	3/4	—	1/4	4-1/2	5/16	5/16	3/8	3-9/32
CL-120-SAC	3/4-10 or M20	8-1/4	1-1/4	1-3/4	4	3/4	—	1/4	7-1/4	5/16	5/16	3/8	3

SERRATED EDGE CLAMPS

BODY AND NOSE: 1018 STEEL, CARBURIZED-HARDENED, BLACK OXIDE FINISH
 CLAMPING SCREW: 4140 STEEL, HEAT TREATED RC 43-45, BLACK OXIDE FINISH
 NOSE COVER: ALUMINUM

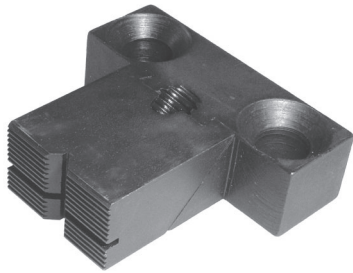

Serrated Fixed Edge Clamp (High Nose)

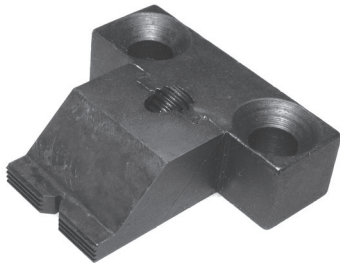

Serrated Fixed Edge Clamp (Low Nose)

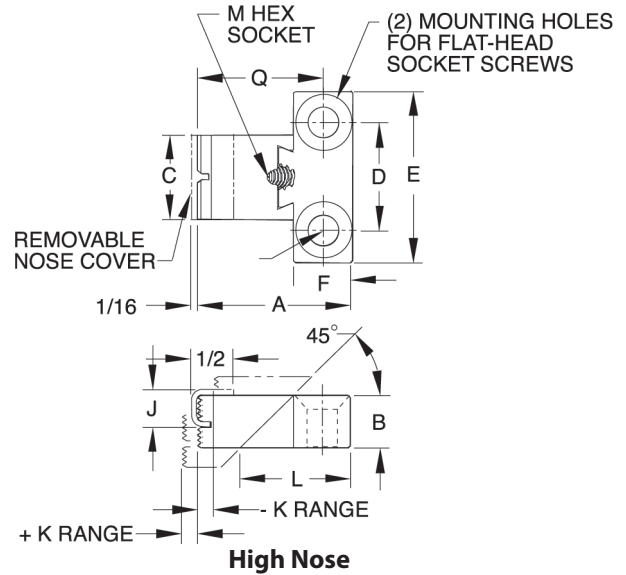

Serrated Fixed Edge Clamps mount in a fixed position, rather than having a slot for adjustment. This makes the clamps more compact and ensures that they are mounted in the correct location without requiring adjustment. The fixed version is usually better for permanent fixtures, while the adjustable version is better for machine-table mounting. The Flat-Head Socket Screws used for mounting absolutely hold proper location (order separately). Choice of three clamp sizes, with either a high nose or low nose.

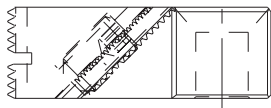

High Nose

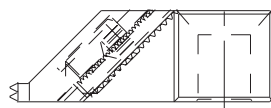

Low Nose

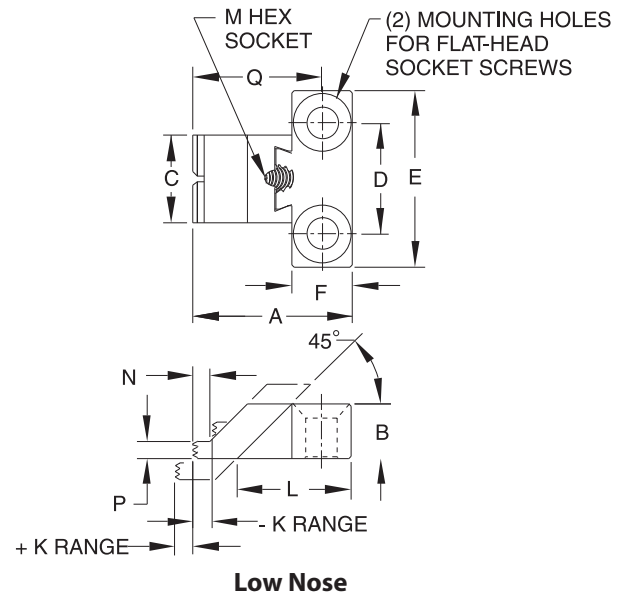

Low Nose

FIXED POSITION — HIGH NOSE

PART NO.	MOUNTING SCREW SIZE	A	B	C	D	E	F	J	K	L	M	N	P	Q	FLAT-HEAD SOCKET SCREWS (2 REQ'D) ORDER SEPARATELY
CL-5-SFC	5/16-18	1-13/16	5/8	1	1	1-3/4	11/16	7/16	1/4	1-5/16	5/32	—	—	1-15/32	CL-5/16-18x1.00-FHSS
CL-45-SFC	1/2-13	2-11/16	7/8	1-1/2	2	3	1	5/8	5/16	1-7/8	1/4	—	—	2-3/16	CL-1/2-13x1.38-FHSS
CL-75-SFC	5/8-11	3-1/2	1-1/4	1-3/4	2	3-1/4	1-1/4	3/4	5/16	2-1/2	5/16	—	—	2-7/8	CL-5/8-11x2.00-FHSS

FIXED POSITION — LOW NOSE

CL-0-SFC	5/16-18	1-13/16	5/8	1	1	1-3/4	11/16	7/16	1/4	1-5/16	5/32	1/8	1/8	1-15/32	CL-5/16-18x1.00-FHSS
CL-40-SFC	1/2-13	2-11/16	7/8	1-1/2	2	3	1	5/8	5/16	1-7/8	1/4	1/4	1/4	2-3/16	CL-1/2-13x1.38-FHSS
CL-70-SFC	5/8-11	3-1/2	1-1/4	1-3/4	2	3-1/4	1-1/4	3/4	5/16	2-1/2	5/16	5/16	3/8	2-7/8	CL-5/8-11x2.00-FHSS

PIVOTING EDGE CLAMPS

BODY: GRAY CAST IRON, ASTM CLASS 40, BLACK OXIDE FINISH
 JAW: 1045 STEEL, HEAT TREATED RC 40-45, BLACK OXIDE FINISH
 BOLT: 4135 STEEL, HEAT TREATED, BLACK OXIDE FINISH



Standard

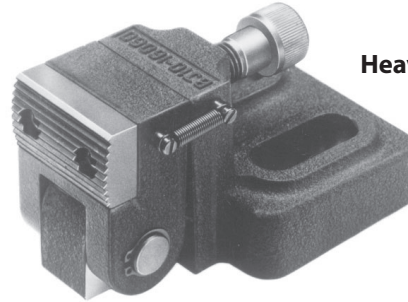

Heavy

Large edge clamp that is ideal for tall workpieces. Pivoting nose pushes forward and downward simultaneously. Can be used to clamp against fixed locators, or against the Downthrust Backstops shown below. Replacement jaws are available.

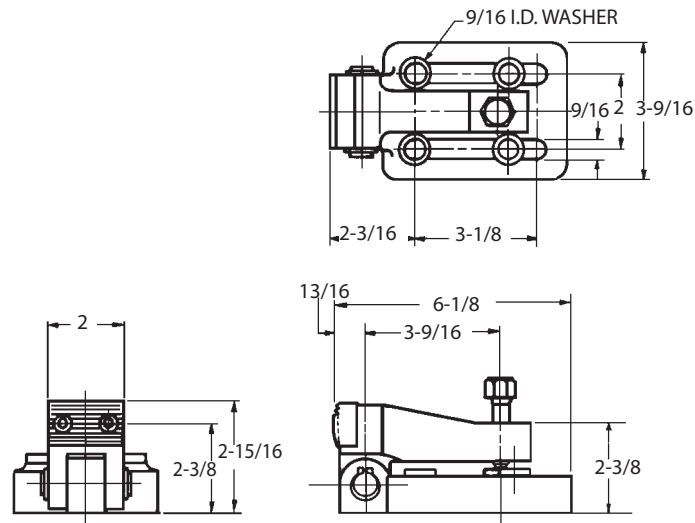
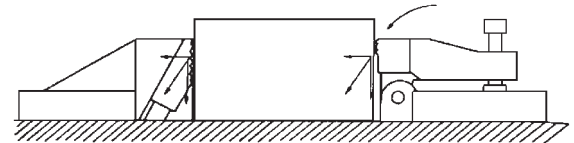

Standard

PIVOTING EDGE CLAMPS

SIZE	PART NO.	MAX. CLAMPING FORCE (LBS)		SOCKET-HEAD CAP SCREWS (2 OR 4 REQD)	REPLACEMENT JAW
		HORIZ	VERT		
STANDARD	CL-MF40-1001	2000	220	(4) CL-1/2-13x2.25-SHCS	CL-MF40-1011
HEAVY	CL-MF50-1001	4200	730	(2) CL-5/8-11x3.00-SHCS	CL-MF40-1011

PIVOTING EDGE CLAMPS

BODY & JAW: 1018 STEEL, BLACK OXIDE FINISH
 EDGE GRIPPER: M-2 TOOL STEEL, HEAT TREATED Rc 60-62, BLACK OXIDE FINISH
 DOWEL PIN: 4140 ALLOY STEEL

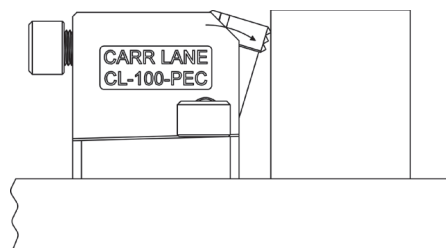

New item!

This edge clamp is well suited for holding large castings and other tall workpieces. The pivoting jaw exerts clamping force forward and downward at the same time. The jaw has a replaceable serrated gripper made of hardened tool steel for high-production durability. The slotted base provides adjustability and has a tapered top surface to prevent the clamp from moving. Fasten with two Socket-Head Cap Screws.

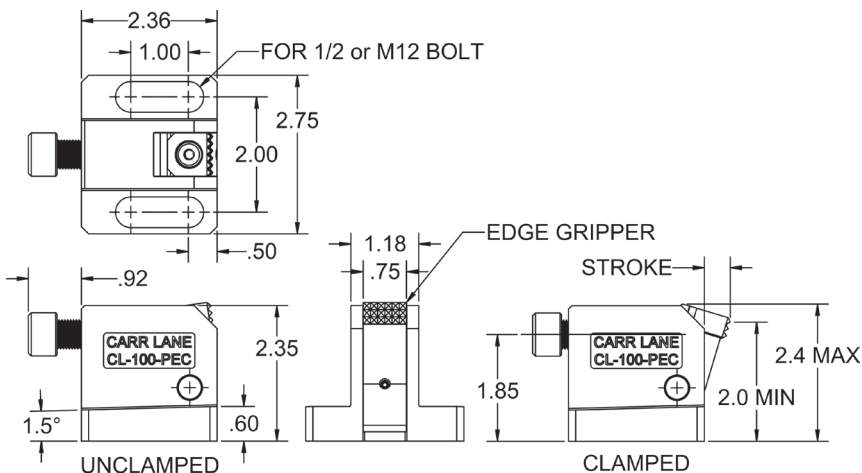
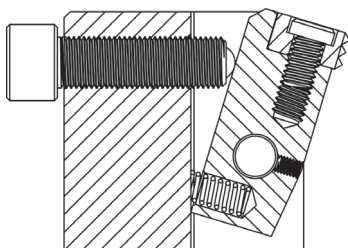

PIVOTING EDGE CLAMP

PART NO.	MAXIMUM CLAMPING STROKE	MOUNTING SCREW SIZE	THRUST SCREW SIZE	BALL-END THRUST SCREW (FURNISHED)	EDGE GRIPPER (FURNISHED)
CL-100-PEC	1/2	1/2-13 or M12	1/2-20	CL-80-BTS-1.75	CL-12-EG-6

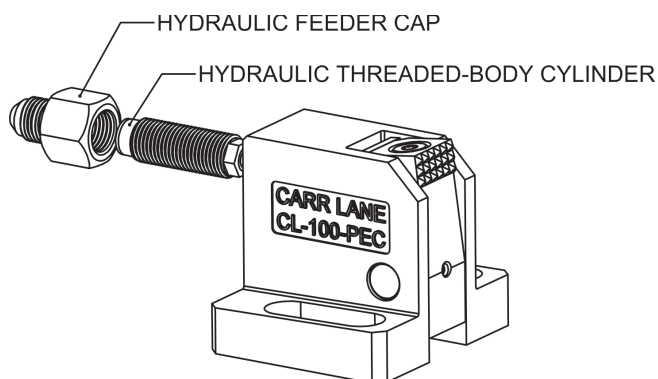

These Pivoting Edge Clamps can be easily converted to hydraulic operation by replacing the standard thrust screw with a Threaded-Body Cylinder and Feeder Cap, then connecting to a hydraulic pressure source. Please see table below for the required conversion accessories. Maximum clamping stroke is reduced to 1/4" when the clamp is converted to hydraulic operation.

HYDRAULIC CONVERSION ACCESSORIES

PART NO.	ITEM DESCRIPTION	MAXIMUM HYDRAULIC PRESSURE (psi)
CLR-802-TB	Hydraulic Threaded-Body Cylinder	7250
CLR-308-TBA	Hydraulic Feeder Cap	7250

LOW PROFILE PIVOTING EDGE CLAMP

BODY AND JAW: 1018 STEEL, BLACK OXIDE
 EDGE GRIPPER: M-2 TOOL STEEL, HEAT TREATED RC 60-62, BLACK OXIDE
 DOWEL PIN: 4140 ALLOY STEEL



New item!

This edge clamp is well suited for holding medium to large castings and other moderate to tall workpieces. The pivoting jaw exerts clamping force forward and downward at the same time. The jaw has a replaceable serrated gripper made of hardened tool steel for high-production durability. The slotted base provides adjustability and has a tapered top surface to prevent the clamp from moving. Fasten with two Socket-Head Cap Screws.

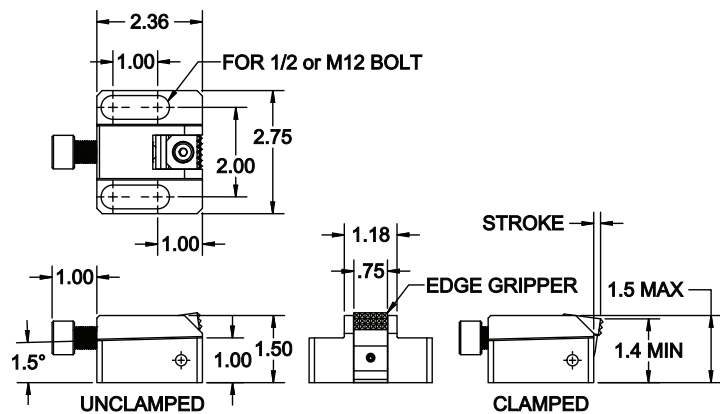

PART NO.	MAXIMUM CLAMPING STROKE	MOUNTING SCREW SIZE	THRUST SCREW SIZE	BALL-END THRUST SCREW (FURNISHED)	EDGE GRIPPER (FURNISHED)
CL-101-PEC	3/8	1/2-13 or M12	1/2-20	CL-80-BTS-1.75	CL-12-EG-6

HYDRAULIC CONVERSION ACCESSORIES

PART NO.	ITEM DESCRIPTION	MAXIMUM HYDRAULIC PRESSURE (psi)
CLR-802-TB	Hydraulic Threaded-Body Cylinder	7250
CLR-802-TBA	Hydraulic Feeder Cap	7250

SWING CLAMPS

TYPES



HOOK CLAMPS – SHORT ARM

Extremely compact swing clamp that mounts in a reamed hole. Compact assembly is ideal for installation in tight spaces and where high clamping forces are required. Choice of socket head (counterbored) or hex-nut type.



HOOK CLAMPS – LONG ARM

Long-arm Hook Clamps are available with either a plain or tapped arm. The tapped-arm version accepts a wide variety of contact bolts or spindles to increase clamping-height range (the tapped arm is slightly longer). Ideal in tight spaces where high clamping force is required.



HOOK CLAMPS – CAM HANDLE

The tapped-arm version is optionally available with a cam handle, to allow clamping without a separate wrench.



ONE-TOUCH QUICK-ACTING SWING CLAMP – HORIZONTAL CAM LEVER

One-Touch Swing Clamps are manually operated clamps that first rotate 70° clockwise into position, then clamp straight down in one continuous motion. The Horizontal Cam Lever is operated by a radial cam lever that swings in an horizontal arc.



ONE-TOUCH QUICK-ACTING SWING CLAMP – VERTICAL CAM LEVER

One-Touch Swing Clamps are manually operated clamps that first rotate 70° clockwise into position, then clamp straight down in one continuous motion. The Vertical Cam Lever is operated by a radial cam lever that swings in a vertical arc. Ideal for confined spaces with no room for a horizontal handle swing.



ONE-TOUCH QUICK-ACTING SWING CLAMP – HEX DRIVE

One-Touch Swing Clamps are manually operated clamps that first rotate 70° clockwise into position, then clamp straight down in one continuous motion. The Hex Drive is operated by a screw mechanism with a hex drive nut. This allows for exact clamping-force control using a torque wrench.



FLOATING CLAMPS

Floating Clamps are position-flexible clamping devices. The top jaw and bottom jaw together provide a floating clamping point that adjusts to the workpiece before locking, to prevent deformation.



SWING CLAMP ASSEMBLIES

Long-reach swing clamp that can be hand-tightened for medium clamping force.



UP-THRUST CLAMP

Combination clamp and locator with a unique upward clamping action. Pushing down the cam handle pulls the lower jaw upward. This clamps the workpiece against the stationary upper jaw, whose bottom surface is a precision-ground locator.

SEE ALSO:



ROEMHELD
HILMA ■ STARK

AIR-POWERED:
p. 604



HYDRAULIC:
p. 622-623



HOOK CLAMPS

CLAMP BODY: 1215 STEEL, CARBURIZED-HARDENED, BLACK OXIDE FINISH



**Standard Arm
Socket Head**

Extremely compact swing clamp that mounts in a reamed hole. Ideal in tight spaces and where high clamping forces are required. Choice of socket head (counterbored) or hex-nut type.

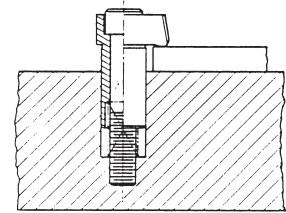

Compact assembly is easy to install in tight spaces. Socket-head type shown above offers a very low profile.



**Standard Arm
Hex Nut**

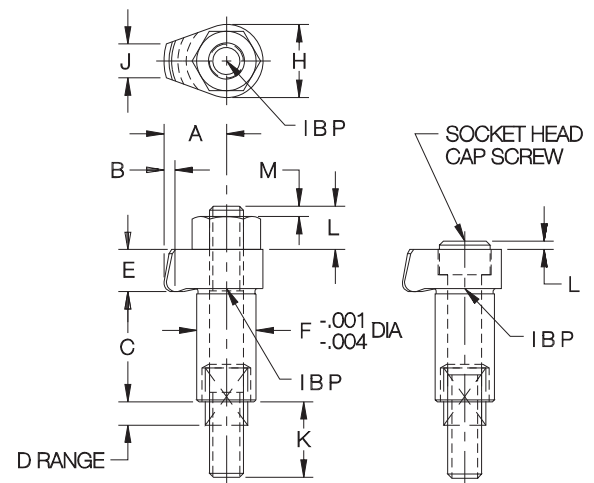

STANDARD ARM, SOCKET HEAD (INCH)

PART NO.	THREAD SIZE	A	B	C	D CLAMPING RANGE	E	F DIA	H DIA	J	K	L	M
CL-1-CAC	5/16-18	.67	.08	.93	.25	.55	.625	.80	.40	.69	.12	—
CL-2-CAC	1/2-13	.92	.12	1.63	.50	.63	.875	1.08	.50	1.13		—
CL-3-CAC	5/8-11	1.30	.18	1.83	.70	.90	1.125	1.38	.75	1.25		—

STANDARD ARM, HEX NUT (INCH)

CL-1-CA	5/16-18	.67	.08	.93	.25	.55	.625	.80	.40	1.14	.30	.06
CL-2-CA	1/2-13	.92	.12	1.63	.50	.63	.875	1.08	.50	1.19	.48	.08
CL-3-CA	5/8-11	1.30	.18	1.83	.70	.90	1.125	1.38	.75	1.57	.61	.09

STANDARD ARM, SOCKET HEAD (METRIC)

PART NO.	THREAD SIZE	THREAD PITCH (mm)	A (mm)	B (mm)	C (mm)	D CLAMPING RANGE (mm)	E (mm)	F DIA NOMINAL	F DIA ACTUAL (mm)	H DIA (mm)	J (mm)	K (mm)	L (mm)	M
CLM-1-CAC	M8	1.25	17	2	24	6.5	14	5/8"	15.88	20.5	10	17	3	—
CLM-2-CAC	M12	1.75	23.5	3	41.5	12.5	16	7/8"	22.22	27.5	12.5	32.5	3	—
CLM-3-CAC	M15	2	33	4.5	46.5	16	23	1-1/8"	28.58	35	19	33.5	3	—

STANDARD ARM, HEX NUT (METRIC)

CLM-1-CAC	M8	1.25	17	2	24	6.5	14	5/8"	15.88	20.5	10	17.5	8	15
CLM-2-CAC	M12	1.75	23.5	3	41.5	12.5	16	7/8"	22.22	27.5	12.5	26	12	2
CLM-3-CAC	M15	2	33	4.5	46.5	16	23	1-1/8"	28.58	35	19	38	16	2

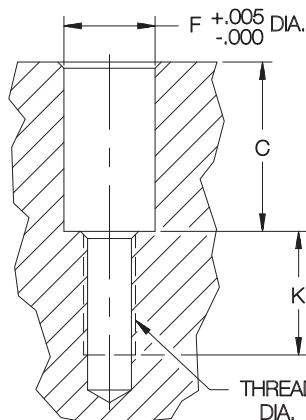

**Installation
Hole**

7

HOOK CLAMPS

CLAMP BODY: 4135 STEEL, HEAT TREATED, BLACK OXIDE FINISH
 SOCKET-HEAD CAP SCREW, BLACK OXIDE FINISH
 SPRING: SPRING STEEL, BLACK OXIDE FINISH



**Long Arm
Socket Head**



**Tapped Long Arm
Socket Head**



**Tapped Long Arm
Cam Handle**

Long-arm Hook Clamps available with either a plain or tapped arm. The tapped-arm version accepts a wide variety of contact bolts or spindles to increase clamping-height range (the tapped arm is also slightly longer). Mounts in a reamed hole or in a Hook-Clamp Mounting Block or Holder (order separately). Ideal in tight spaces where high clamping force is required. Available in three sizes.

The tapped-arm version is optionally available with a cam handle, to allow clamping without a separate wrench. Use with an adjustable contact bolt to utilize maximum cam travel.

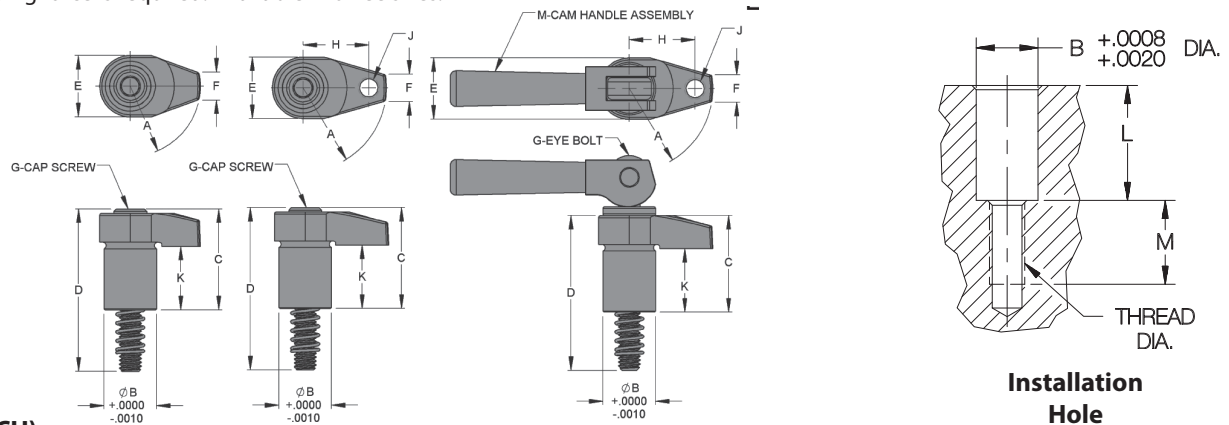

LONG ARM (INCH)

PART NO.		THREAD DIA	A	B	C	D	E	F	G	H	J	K	L	M	MAXIMUM ALLOWABLE TORQUE (FT-LBS)	MAXIMUM CLAMPING FORCE (LBS)
SOCKET HEAD	CAM HANDLE															
CL-MF25-5002	—	5/16-18	1	.7500	1-7/16	2-5/16	7/8	3/8	5/16-18	—	—	29/32	15/16	15/16	22	2200
CL-MF40-5002	—	1/2-13	2	1.0000	2-1/2	3-1/2	1-1/4	11/16	1/2-13	—	—	1-17/32	1-9/16	1	34	2700
CL-MF50-5002	—	5/8-11	2	1.2500	2-7/8	3-7/8	1-7/16	1-7/16	5/8-11	—	—	1-17/32	1-9/16	1	59	3700

TAPPED LONG ARM (INCH)

CL-MF25-5013	CL-MF25-5020	5/16-18	1	.7500	1-7/16	2-5/16	7/8	3/8	5/16-18	15/16	5/16-18	29/32	15/16	15/16	22	2200
CL-MF40-5013	CL-MF40-5020	1/2-13	2	1.0000	2-1/2	3-1/2	1-1/4	11/16	1/2-13	1-13/16	1/2-13	1-17/32	1-9/16	1	34	2700
CL-MF50-5014	CL-MF50-5020	5/8-11	2	1.2500	2-7/8	3-7/8	1-7/16	1-7/16	5/8-11	1-13/16	5/8-11	1-17/32	1-9/16	1	59	3700

STANDARD ARM, SOCKET HEAD (METRIC)

PART NO.	THREAD SIZE	THREAD PITCH (mm)	A (mm)	B (mm)	C (mm)	D CLAMPING RANGE (mm)	E (mm)	F DIA NOMINAL	F DIA ACTUAL (mm)	H DIA (mm)	J (mm)	K (mm)	L (mm)	M
CLM-1-CAC	M8	1.25	17	2	24	6.5	14	5/8"	15.88	20.5	10	17	3	—
CLM-2-CAC	M12	1.75	23.5	3	41.5	12.5	16	7/8"	22.22	27.5	12.5	32.5	3	—
CLM-3-CAC	M15	2	33	4.5	46.5	16	23	1-1/8"	28.58	35	19	33.5	3	—

HEX NUT (METRIC)

CLM-1-CAC	M8	1.25	17	2	24	6.5	14	5/8"	15.88	20.5	10	17.5	8	15
CLM-2-CAC	M12	1.75	23.5	3	41.5	12.5	16	7/8"	22.22	27.5	12.5	26	12	2
CLM-3-CAC	M15	2	33	4.5	46.5	16	23	1-1/8"	28.58	35	19	38	16	2

HOOK-CLAMP MOUNTING BLOCKS

1018 STEEL, BLACK OXIDE FINISH

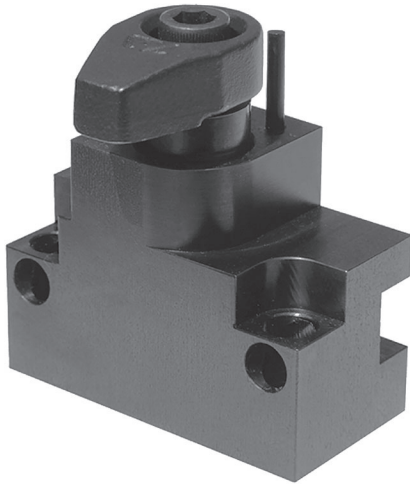

Hook-Clamp Mounting Block
(order Hook-Clamp separately)

These mounting blocks for long-arm Hook Clamps have built-in 90° stops that provide consistent arm positioning in both clamped and unclamped position. Two sets of mounting holes allow either base mounting or side mounting. Precision bored hole for smooth swing action. Available for all three sizes of long-arm Hook Clamps.

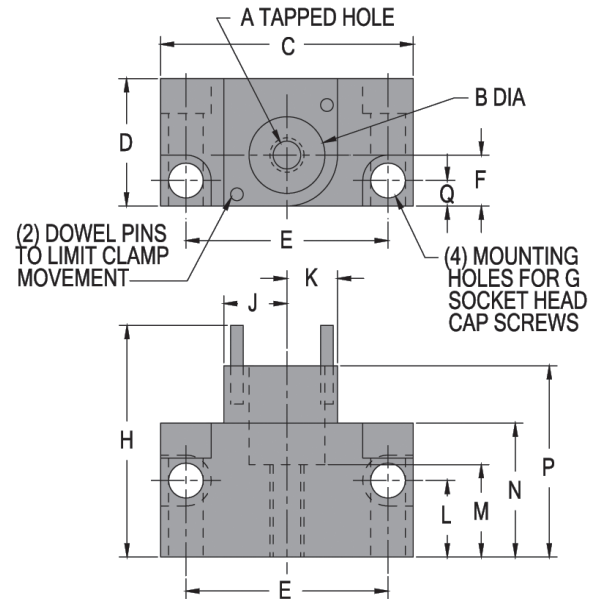
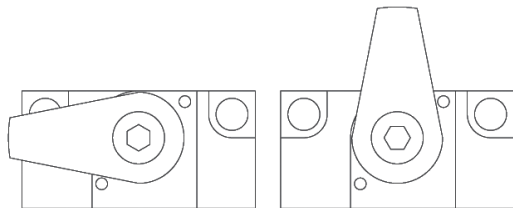

7

HOOK-CLAMP MOUNTING BLOCKS (INCH)

PART NO.	A	B	C	D	E	F	G	H	J	K	L	M	N	P	Q
CL-MF25-5801	5/16-18	.7500	2-1/2	1-1/4	2	1/2	5/16-18 or M8	2-1/2	5/8	1/2	3/4	29/32	1-5/16	1-7/8	1/4
CL-MF40-5801	1/2-13	1.0000	2-3/4	2	2	1	1/2-13 or M12	3-3/4	1	3/4	1	1-5/32	1-7/8	2-3/4	3/8
CL-MF50-5801	5/8-11	1.2500	5	2	4	1	5/8-11 or M16	3-3/4	1	1	1-1/4	1-5/32	2-1/4	2-3/4	1/2

HOOK-CLAMP MOUNTING BLOCKS (METRIC)

CL-MF08-5801	M8	.7087 (18mm)	1.97	1.00	1.50	.47	M6 or 1/4-20	2.50	.55	.55	.71	.91	.98	1.87	.25
CL-MF12-5801	M12	.9843 (25mm)	2.95	1.50	2.17	.65	M10 or 3/8-16	3.64	.79	.79	.94	1.16	1.38	2.64	.35
CL-MF16-5801	M16	1.2598 (32mm)	3.46	1.75	2.56	.77	M12 or 1/2-13	4.43	.94	.94	1.26	1.16	1.77	3.43	.39

HOOK-CLAMP HOLDERS

1045 STEEL, BLACK OXIDE FINISH

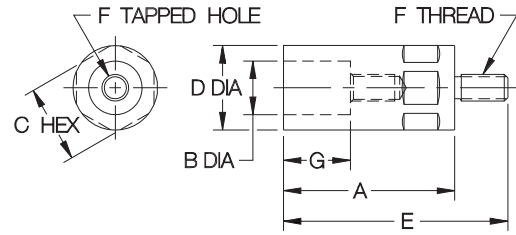
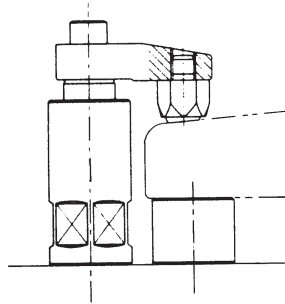

HOOK-CLAMP HOLDERS (INCH)

PART NO.	F THREAD DIA	A	B DIA	C	D DIA	E	G
CL-MF25-5101	5/16-18	2-1/4	.7500	7/8	1	3	15/16
CL-MF40-5101	1/2-13	3-1/8	1.0000	1-7/16	1-9/16	4-3/8	1-9/16
CL-MF40-5102		4				5-1/4	
CL-MF50-5101	5/8-11	3-1/8	1.2500	1-3/4	2	4-3/8	1-9/16
CL-MF50-5102		4				5-1/4	

Compact mounting adapter for long-arm Hook-Clamps. Precision bored hole for smooth swing action.

HOOK-CLAMP HOLDERS (METRIC)

PART NO.	F THREAD	A	B DIA	C	D DIA	E	G
CL-MF08-5101	M8	2.17	.7087 (18mm)	.87 (22mm)	.94	2.91	.98
CL-MF12-5101	M12	3.15	.9843 (25mm)	1.42 (36mm)	1.57	4.33	1.57
CL-MF16-5101	M16	3.15	1.2598 (32mm)	1.81 (46mm)	1.97	4.33	1.57

7

RISER CYLINDERS

1045 STEEL, BLACK OXIDE FINISH

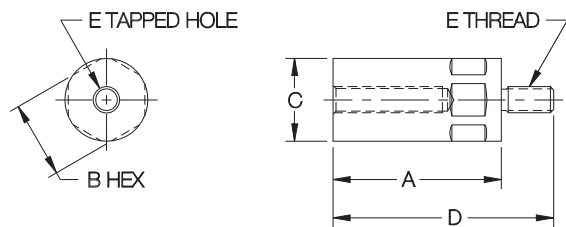
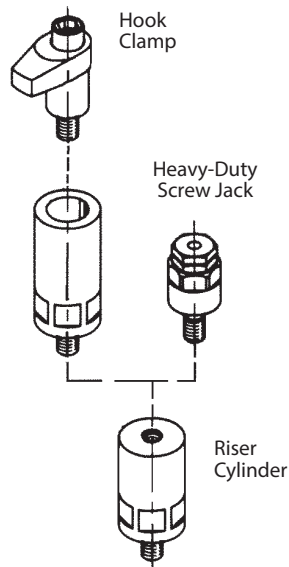

Provides additional height without taking up much space. Useful with Hook Clamps, and Heavy-Duty Screw Jacks.

PART NO.	A	B	C DIA	D	E
CL-MF25-5201	1-1/4	7/8	1	2	5/16-18
CL-MF25-5202	1-1/2			2-1/4	
CL-MF25-5203	2			2-3/4	
CL-MF40-5201	2	1-7/16	1-9/16	3-1/4	1/2-13
CL-MF40-5203	3-1/8			4-3/8	
CL-MF40-5204	4			5-1/4	
CL-MF50-5201	2	1-13/16	2	3-1/4	5/8-11
CL-MF50-5203	3-1/8			4-3/8	
CL-MF50-5204	4			5-1/4	

ONE-TOUCH QUICK-ACTING SWING CLAMPS

BASE, SPINDLE, AND LEVER: 1045 STEEL, HEAT TREATED, BLACK OXIDE FINISH
 CLAMPING-ARM BODY AND SPIRAL-CAM SHAFT: ALLOY STEEL, HEAT TREATED, BLACK OXIDE FINISH
 KNOB HANDLE: BLACK PHENOLIC PLASTIC

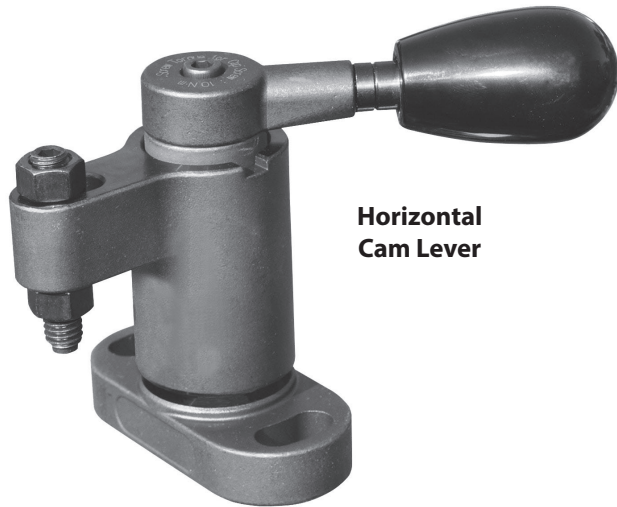

Horizontal Cam Lever

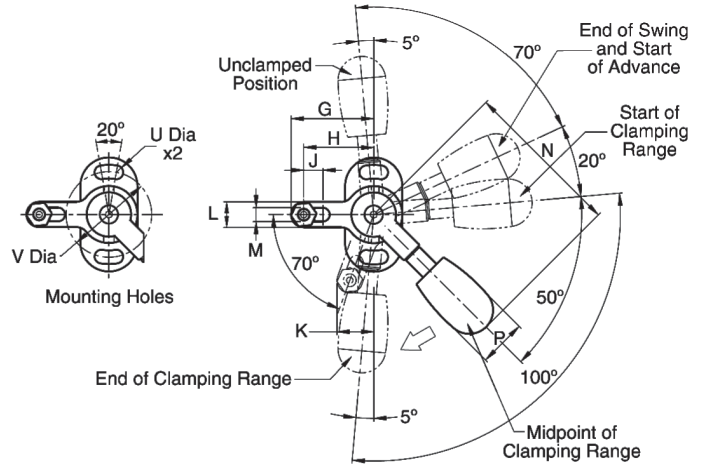

One-Touch Swing Clamps are manually operated clamps that first rotate 70° clockwise into position then clamp straight down in one continuous motion. The version shown here is operated by a radial cam lever that swings in an horizontal arc. Available in four sizes.

Starting with the clamping arm swung away for loading, turn the lever to rotate the arm into clamping position and automatically move the arm downward to apply clamping force. A small portion of the total vertical stroke is used to swing, and slightly advance the clamping arm, then the remaining stroke is available as the clamping range. To unclamp, reverse the lever movement to lift the arm straight up and automatically return the arm to its original position for loading.

Mount clamp with two socket-head cap screws using the two mounting slots. To allow for workpiece variation, adjust spindle extension so that full clamping force is achieved approximately in the middle of the lever's 100° clamping range.

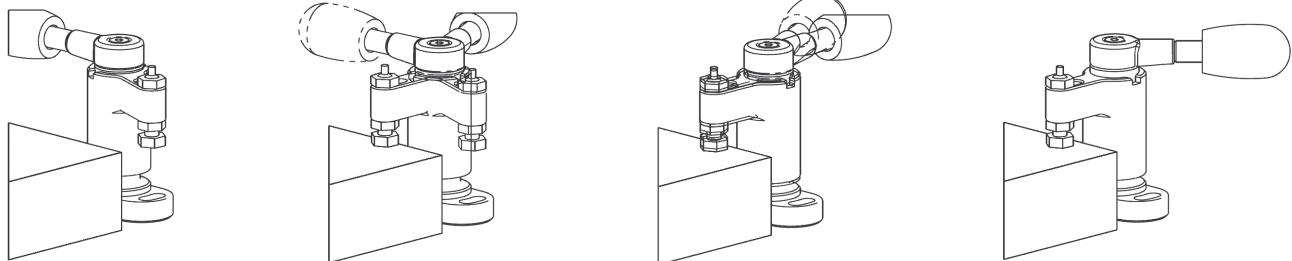
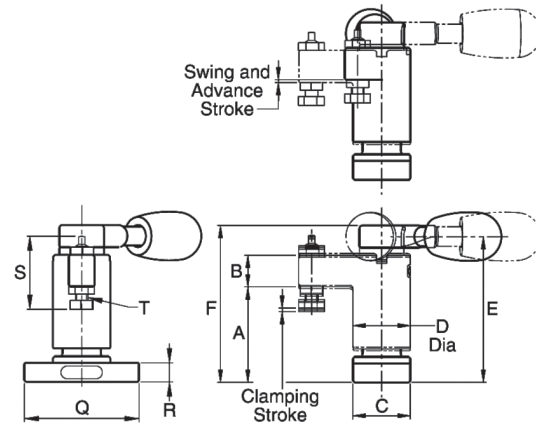

1. Starting position, with clamping arm swung away for loading.
2. Turn lever (70°) to rotate the arm into clamping position.
3. Continue turning lever (through 90°) to advance the arm toward the workpiece.
4. Continue turning lever (90° to 190°) until full clamping force is applied.

HORIZONTAL CAM LEVER (INCH)

PART NO.	MAX CLAMPING FORCE (LBS)	MAX. ALLOWABLE TORQUE (FT-LBS)	SWING AND ADVANCE STROKE	CLAMPING STROKE (MAX.)	A			B	C	D DIA	E	F	G	H	J	K	L	M	N	P DIA	Q	R	S	T SOCKET SET-SCREW	U DIA	V DIA
					UN-CLAMPED POSITION	START OF CLAMPING RANGE	END OF CLAMPING RANGE																			
CL-100-QSCR	250	4	.03	.04	1.21	1.18	1.14	.39	.71	.71	1.80	1.93	1.02	1.02	.24	.45	.31	.169	1.97	.59	1.42	.24	.88	#8-32	.169	1.063
CL-150-QSCR	400	7	.04	.06	1.62	1.58	1.52	.55	.91	.91	2.41	2.60	1.38	1.18	.31	.60	.39	.209	2.48	.79	1.77	.31	1.00	#10-24	.209	1.339
CL-200-QSCR	500	12	.05	.06	2.02	1.97	1.91	.71	1.18	1.18	3.01	3.23	1.77	1.46	.31	.81	.63	.331	3.15	1.02	2.56	.47	1.50	5/16-18	.331	1.890
CL-300-QSCR	800	23	.07	.07	2.43	2.36	2.29	.87	1.57	1.57	3.66	3.94	2.17	1.77	.31	1.00	.79	.409	3.94	1.30	3.35	.59	2.00	3/8-16	.409	2.520

ONE-TOUCH QUICK-ACTING SWING CLAMPS

BASE, WASHER, AND SPINDLE: 1045 STEEL, HEAT TREATED, BLACK OXIDE FINISH
 CLAMPING-ARM BODY AND CAM HANDLE: ALLOY STEEL, HEAT TREATED, BLACK OXIDE FINISH



**Vertical
Cam Handle**

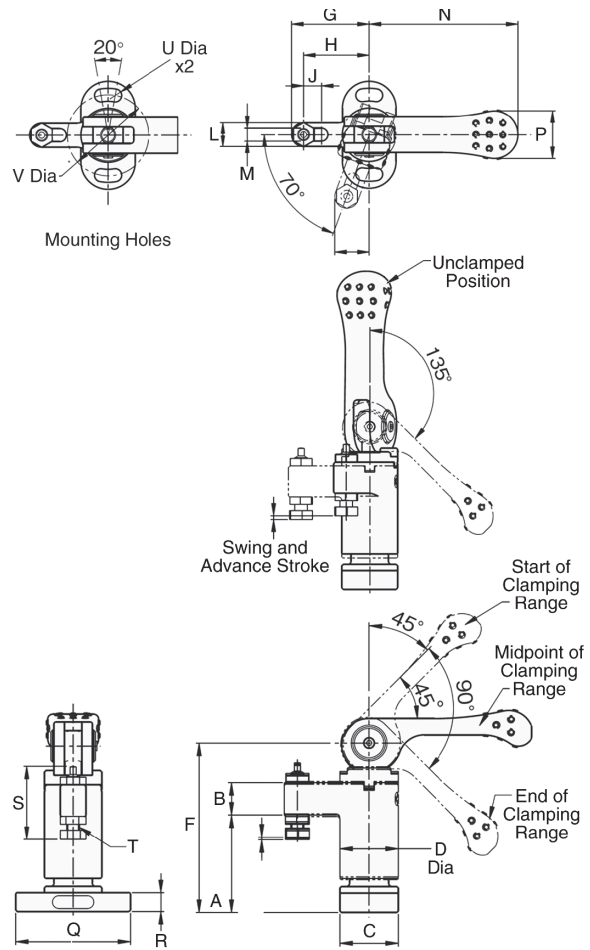

One-Touch Swing Clamps are manually operated clamps that first rotate 70° clockwise into position then clamp straight down in one continuous motion. The version shown here is operated by a cam handle that swings in a vertical arc. Ideal for confined spaces with no room for a horizontal handle swing. Available in four sizes.

Starting with the handle upright and the clamping arm swung away for loading, first twist the handle to rotate the arm into clamping position, then push the handle downward to lower the arm and apply clamping force. A small portion of the total vertical stroke is used to swing, and slightly advance the clamping arm, then the remaining stroke is available as the clamping range. Reverse the process to unclamp and return the arm to its original position for loading.

Mount clamp with two socket-head cap screws using the two mounting slots. To allow for workpiece variation, adjust spindle extension so that full clamping force is achieved approximately in the middle of the lever's 100° clamping range.

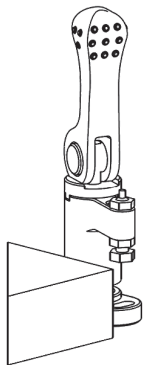

1. Starting position, with handle upright and clamping arm swung away for loading.

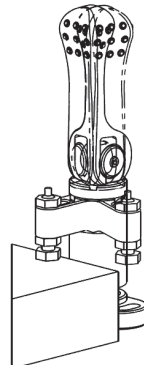

2. Twist handle (70°) to rotate the arm into clamping position.

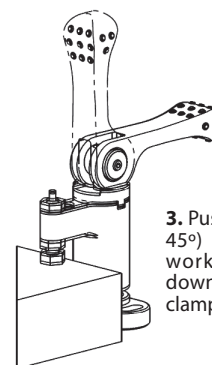

3. Push handle downward (through 45°) to advance the arm to the workpiece. Continue pushing downward (45° to 135°) until full clamping force is applied.

VERTICAL CAM HANDLE (INCH)

PART NO.	MAX CLAMPING FORCE (LBS)	MAX. ALLOWABLE TORQUE (FF-LBS)	SWING AND ADVANCE STROKE	CLAMPING STROKE (MAX.)	A			B	C	D DIA	F	G	H	J	K	L	M	N	P	Q	R	S	T SOCKET SET-SCREW	U DIA	V DIA
					UN-CLAMPED POSITION	START OF CLAMPING RANGE	END OF CLAMPING RANGE																		
CL-100-QSCV	180	4	.03	.04	1.21	1.18	1.14	.39	.71	.71	2.05	1.02	.87	.24	.45	.31	.169	1.97	.63	1.42	.24	.88	#8-32	.169	1.063
CL-150-QSCV	340	7	.04	.06	1.62	1.58	1.52	.55	.91	.91	2.68	1.38	1.18	.31	.60	.39	.209	2.48	.75	1.77	.31	1.00	#10-24	.209	1.339
CL-200-QSCV	470	12	.05	.06	2.02	1.97	1.91	.71	1.18	1.18	3.43	1.77	1.46	.31	.81	.63	.331	3.15	.94	2.56	.47	1.50	5/16-18	.331	1.890
CL-300-QSCV	630	22	.07	.07	2.43	2.36	2.29	.87	1.57	1.57	4.21	2.17	1.77	.31	1.00	.79	.409	3.94	1.8	3.35	.59	2.00	3/8-16	.409	2.520

ONE-TOUCH QUICK-ACTING SWING CLAMPS

BASE, WASHER, SPINDLE, AND HEX DRIVE NUT: 1045 STEEL, HEAT TREATED, BLACK OXIDE FINISH
CLAMPING-ARM BODY: ALLOY STEEL, HEAT TREATED, BLACK OXIDE FINISH



Hex Drive

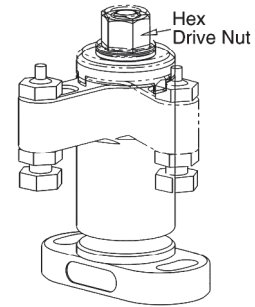

Starting with the clamping arm swung away for loading, tighten the flange nut to rotate the arm into clamping position and automatically move the arm downward to apply clamping force.

One-Touch Swing Clamps are manually operated clamps that first rotate 70° clockwise into position then clamp straight down in one continuous motion. The version shown here is operated by a screw mechanism with a hex drive nut. This allows for exact clamping-force control using a torque wrench. The screw mechanism also provides a longer clamping stroke and greater clamping force than the versions with cam locking. Available in four sizes.

Starting with the clamping arm swung away for loading, tighten the hex drive nut to rotate the arm into clamping position and automatically move the arm downward to apply clamping force. A small portion of the total vertical stroke is used to swing the clamping arm, then the remaining stroke is available as the clamping range. To unclamp, turn the flange nut counter-clockwise to lift the arm straight up and automatically return the arm to its original position for loading.

Mount clamp with two socket-head cap screws using the two mounting slots. To allow for workpiece variation, adjust spindle extension so that full clamping force is achieved approximately in the middle of the lever's 100° clamping range.

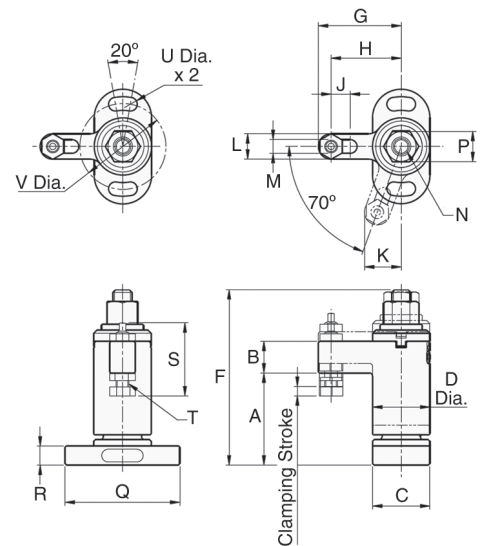

HEX DRIVE (INCH)

PART NO.	MAX CLAMPING FORCE (LBS)	MAX. ALLOWABLE TORQUE (FF-LBS)	SWING AND ADVANCE STROKE	CLAMPING STROKE (MAX.)	A			B	C	D DIA	F	G	H	J	K	L	M	N	P	Q	R	S	T SOCKET SET-SCREW	U DIA	V DIA
					UN-CLAMPED POSITION	START OF CLAMPING RANGE	END OF CLAMPING RANGE																		
CL-100-QSCH	500	4.5	.02	.12	1.16	1.14	1.02	.39	.71	.71	2.22	1.02	.87	.24	.45	.31	.169	1/4-20	7/16	1.42	.24	.88	#8-32	.169	1.063
CL-150-QSCH	800	8	.02	.16	1.56	1.54	1.38	.55	.91	.91	2.89	1.38	1.18	.31	.60	.39	.209	5/16-18	1/2	1.77	.31	1.00	#10-24	.209	1.339
CL-200-QSCH	1300	21	.03	.16	1.92	1.89	1.73	.71	1.18	1.18	3.58	1.77	1.46	.31	.81	.63	.331	3/8-16	9/16	2.56	.47	1.50	5/16-18	.331	1.890
CL-300-QSCH	1700	33	.03	.20	2.31	2.28	2.08	.87	1.57	1.57	4.49	2.17	1.77	.31	1.00	.79	.409	1/2-13	3/4	3.35	.59	2.00	3/8-16	.409	2.520

UP-THRUST CLAMPS

STEEL, WEAR SURFACES HARDENED, BLACK OXIDE FINISH

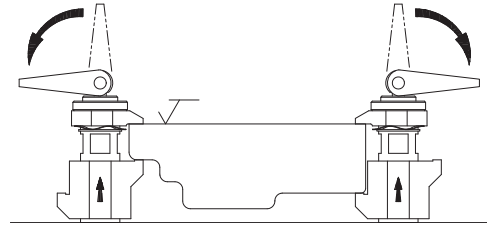

Up-Thrust Clamps locate off of the part's top surface and clamp up from below.

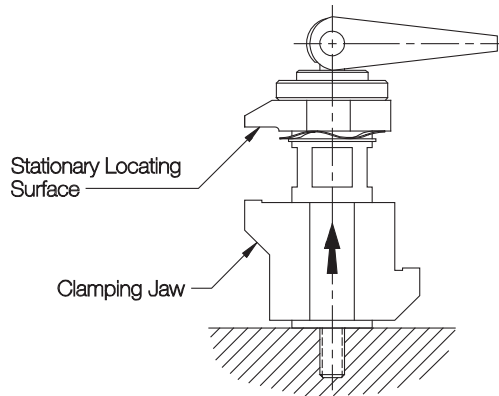

7

Combination clamp and locator with a unique upward clamping action. Pushing down the cam handle pulls the lower jaw upward. This clamps the workpiece against the stationary upper jaw, whose bottom surface is a precision-ground locator.

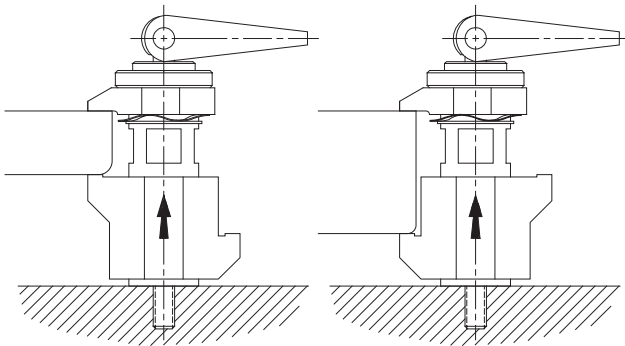

The lower jaw has two clamping surfaces 180° apart, one for thinner parts, the other for thicker parts. The cam handle rotates to screw the lower jaw up or down for fine adjustment.

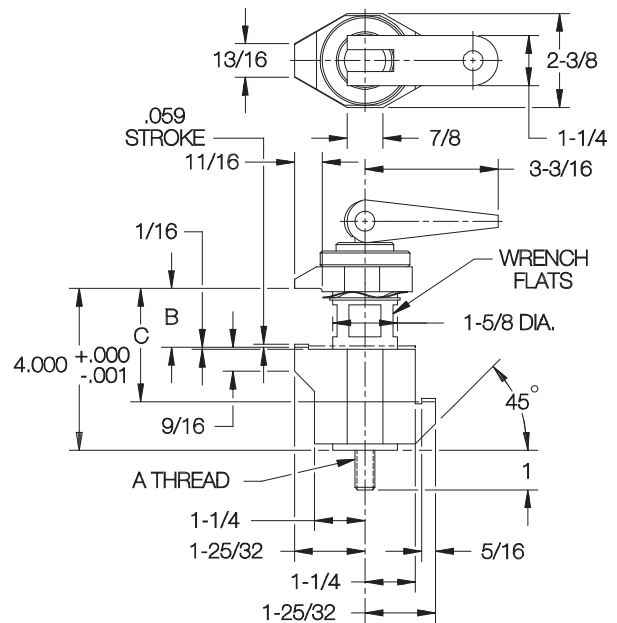

PART NO.	A	B RANGE		C RANGE		MAX CLAMPING FORCE (LBS)
		MIN	MAX	MIN	MAX	
CL-MF40-5301	1/2-13	0	1-3/8	1-3/8	2-3/4	2200

FLOATING CLAMPS

HOUSING: ALUMINUM, ANODIZED GREEN.
 BODY: STEEL, CASE HARDENED & NITRIDED, MANGANESE PHOSPHATE TREATED AND GROUND.
 CLAMPING JAWS: STEEL, CASE HARDENED & NITRIDED, MANGANESE PHOSPHATE TREATED.



Floating Clamps are position-flexible clamping devices. The top jaw and bottom jaw together provide a floating clamping point that adjusts to the workpiece before locking, to prevent deformation. These combination clamp/supports are often used in conjunction with primary locators and clamps, providing additional support points to reduce machining vibration. Floating Clamps are especially useful for clamping forgings, ribbed or flanged castings, and other larger parts.

Install the clamp in a 1/2-13 threaded mounting hole by tightening using the body wrench flats. Adjust the height-limit stop and the swing range with the three setscrews in the green housing. When setting the height limit, consider the full range of workpiece tolerance.

To initiate clamping, push the Floating Clamp downward, then immediately swing the jaws into clamping position. The clamping jaws will automatically rise so that the bottom jaw contacts the workpiece with a light spring force. Next, tighten the top hex nut 11 ft-lbs minimum to 22 ft-lbs maximum, depending on the support load capacity desired. During the tightening process, the workpiece is clamped and simultaneously supported. Releasing is done in reverse order.

For more information and videos, see our online catalog at carrlane.com.

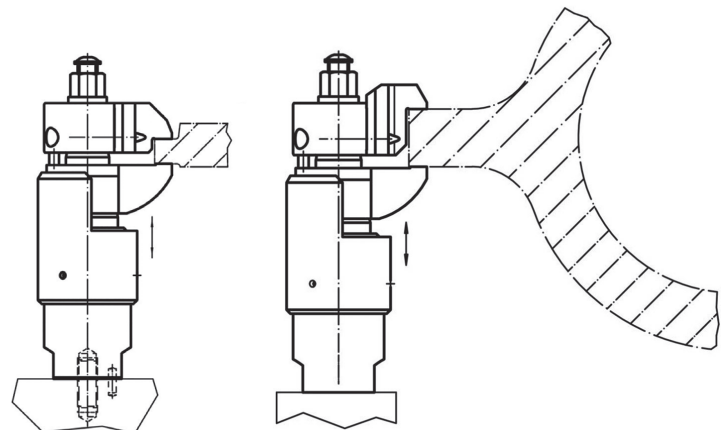
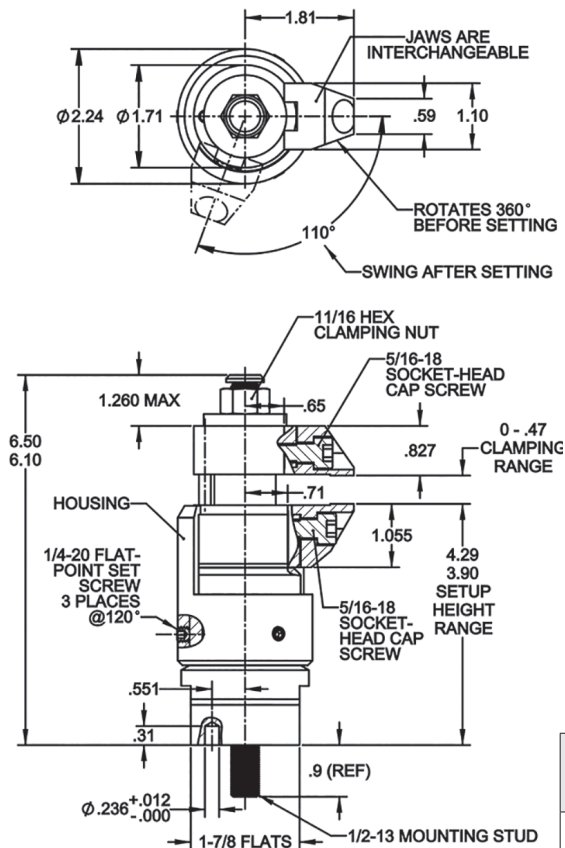

For custom applications, the standard upper clamping jaw supplied can be replaced by a special clamping jaw.

PART NO.	MOUNTING STUD	SUPPORT LOAD CAPACITY AT MINIMUM TIGHTENING TORQUE	SUPPORT LOAD CAPACITY AT MAXIMUM TIGHTENING TORQUE
CL-800-FLC	1/2-13	450 lbs @ 11 ft-lbs	1800 lbs @ 22 ft-lbs

SWING CLAMP ASSEMBLIES

ARM: NODULAR IRON PER ASTM A536 GRADE 65-45-12, ZINC PLATED CLEAR CHROMATE
 ALL OTHER PARTS: MILD STEEL, BLACK OXIDE FINISH



**Knob Handle
Post Mounted**

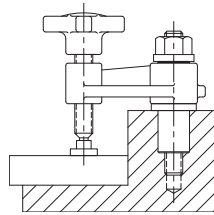

Long-reach swing clamp that can be hand tightened for medium clamping force. The post-mounted version is ideal for tight spaces, with a long mounting post for increased strength. Swing arm can be turned over for more clearance underneath. Install in a reamed hole. To order with a Delrin® foot instead of steel, add "N" to the part number. Example: CL-1-SWA-1N.

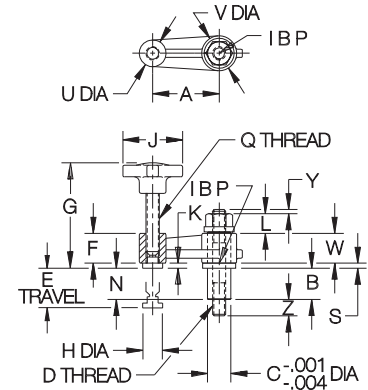

KNOB HANDLE, POST MOUNTED (INCH)

PART NO.	D THREAD SIZE	A	B	C DIA		E	F	G	H DIA	J	K	L	N	Q	S	U DIA	V DIA	W	Y	Z
				NOMINAL	ACTUAL															
CL-1-SWA-1	5/16-18	1-1/2	.80	9/16	.563	.69	3/4	2.45	1/2	1-3/4	5/32	3/8	.68	5/16-18	.16	11/16	15/16	3/4	.11	.80
CL-4-SWA-1	1/2-13	2	1.18	7/8	.875	1.50	1-1/8	3.88	3/4	2-1/8	3/16	11/16	.99	1/2-13	.19	1	1-5/16	1-1/8	.15	.67
CL-5-SWA-1		2-1/2																		
CL-2-SWA-1	5/8-11	3	1.55	1-1/8	1.125	1.59	1-5/16	4.56	15/16	2-3/4	7/32	13/16	1.33	5/8-11	.22	1-5/16	1-3/4	1-1/2	.18	.74
CL-3-SWA-1		4																		

KNOB HANDLE, POST MOUNTED (METRIC)

PART NO.	D THREAD SIZE	THREAD PITCH (mm)	A (mm)	B (mm)	C DIA (mm)	E (mm)	F (mm)	G (mm)	H DIA (mm)	J (mm)	K (mm)	L (mm)	N (mm)	Q THREAD	S (mm)	U DIA (mm)	V DIA (mm)	W (mm)	Y (mm)	Z (mm)
CLM-4-SWA-1	M12	1.75	51	30	22	38	28.5	98.5	19	54	5	17	25	1/2-13	5	25.5	33.5	28.5	3.5	25.5
CLM-5-SWA-1																				
CLM-2-SWA-1	M16	2	76	39.5	28	40	33.5	116	24	70	5.5	21	34	5/8-11	5.5	33.5	44.5	38	4	17
CLM-3-SWA-1																				



**Ball Handle
Post Mounted**

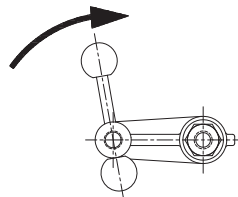

Same as above, except with a sliding ball handle for increased leverage.

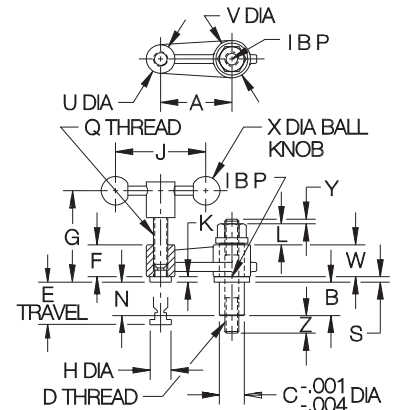

BALL HANDLE, POST MOUNTED (INCH)

PART NO.	D THREAD SIZE	A	B	C DIA		E	F	G	H DIA	J	K	L	N	Q	S	U DIA	V DIA	W	X	Y	Z
				NOMINAL	ACTUAL																
CL-1-SWA-2	5/16-18	1-1/2	.80	9/16	.563	.88	3/4	2.39	1/2	2-1/4	5/32	3/8	.68	5/16-18	.16	11/16	15/16	3/4	3/4	.11	.80
CL-4-SWA-2	1/2-13	2	1.18	7/8	.875	.96	1-1/8	3.53	3/4	2-5/8	3/16	11/16	.99	1/2-13	.19	1	1-5/16	1-1/8	1	.15	.67
CL-5-SWA-2		2-1/2																			
CL-2-SWA-2	5/8-11	3	1.55	1-1/8	1.125	1.65	1-5/16	4.50	15/16	3	7/32	13/16	1.33	5/8-11	.22	1-5/16	1-3/4	1-1/2	1-3/8	.18	.74
CL-3-SWA-2		4																			

BALL HANDLE, POST MOUNTED (METRIC)

PART NO.	D THREAD SIZE	THREAD PITCH (mm)	A (mm)	B (mm)	C DIA (mm)	E (mm)	F (mm)	G (mm)	H DIA (mm)	J (mm)	K (mm)	L (mm)	N (mm)	Q THREAD	S (mm)	U DIA (mm)	V DIA (mm)	W (mm)	X (mm)	Y (mm)	Z (mm)
CLM-4-SWA-2	M12	1.75	51	30	22	24.5	28.5	90	19	66.5	5	17	25	1/2-13	5	25.5	33.5	28.5	25.5	3.5	25.5
CLM-5-SWA-2																					
CLM-2-SWA-2	M16	2	76	39.5	28	42	33.5	114	24	76	5.5	21	34	5/8-11	5.5	33.5	44.5	38	35	4	17
CLM-3-SWA-2																					

SWING CLAMP ASSEMBLIES

ARM: NODULAR IRON PER ASTM A536 GRADE 60-40-18, ZINC PLATED CLEAR CHROMATE
ALL OTHER PARTS: MILD STEEL, BLACK OXIDE FINISH

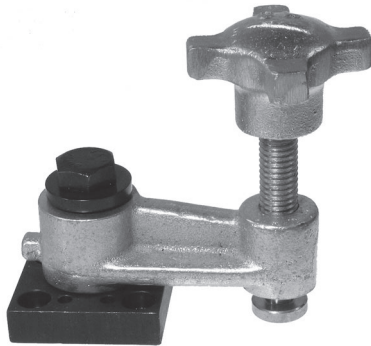

**Knob Handle
Flange Mounted**

Long-reach swing clamp that can be hand tightened for medium clamping force. The flange-mounted version is ideal for mounting on flat surfaces. The stop pin furnished can be installed on either side for clockwise or counterclockwise rotation. Swing arm can be turned over for more clearance underneath. To order with a Delrin® foot instead of steel, add "N" to the part number. Example: CL-1-SWA-3N.

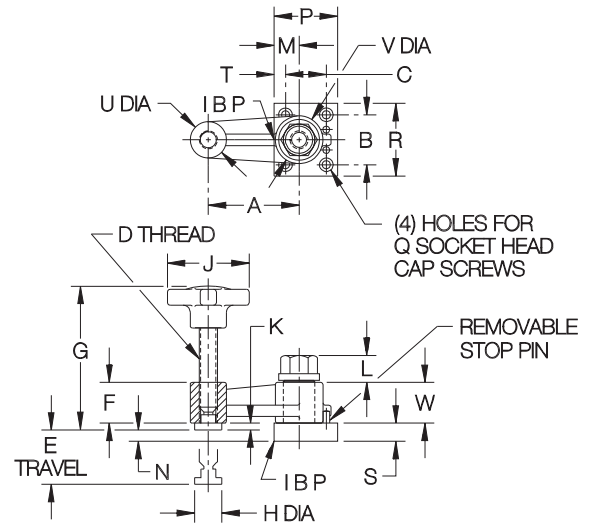
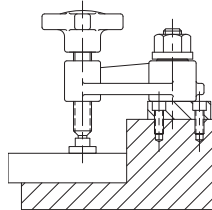

KNOB HANDLE, FLANGE MOUNTED

PART NO.	D THREAD SIZE	A	B	C	E	F	G	H DIA	J	K	L	M	N	P	Q	R	S	T	U	V	W
CL-1-SWA-3	5/16-18	1-1/2	1	3/4	.69	3/4	2.45	1/2	1-3/4	5/32	.33	1/2	.25	1-1/4	#10 or M5	1-1/2	3/8	1/4	11/16	15/16	3/4
CL-4-SWA-3	1/2-13	2	1-3/8	1-1/8	1.50	1-1/8	3.88	3/4	2-1/8	3/16	.44	11/16	.31	1-3/4	1/4 or M6	2	1/2	5/16	1	1-5/16	1-1/8
CL-5-SWA-3		2-1/2																			
CL-2-SWA-3	5/8-11	3	1-1/2	1-1/4	1.59	1-5/16	4.56	15/16	2-3/4	7/32	.58	1	.53	2-1/4	3/8 or M10	2-1/4	3/4	3/8	1-5/16	1-3/4	1-1/2
CL-3-SWA-3		4																			

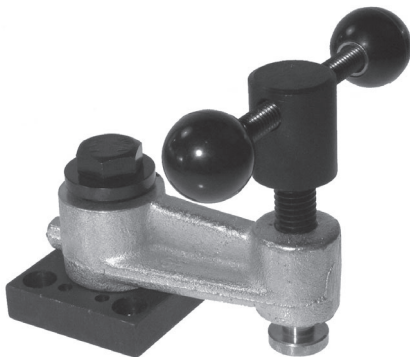

**Ball Handle
Flange Mounted**

Same as above, except with a sliding ball handle for increased leverage.

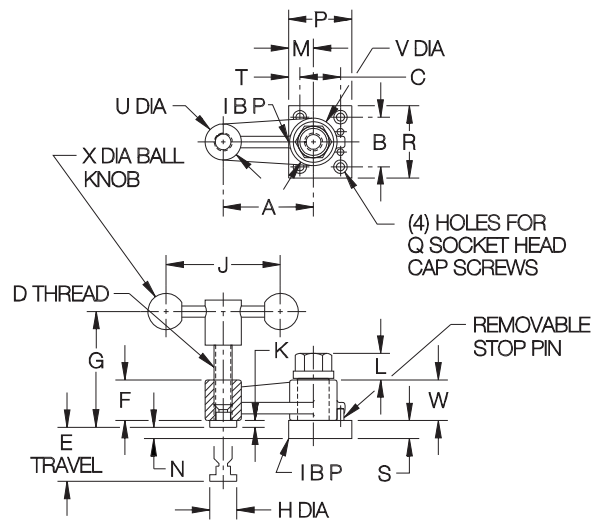
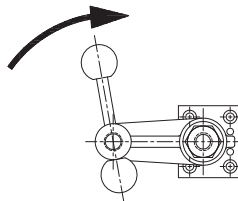

BALL HANDLE, FLANGE MOUNTED

PART NO.	D THREAD SIZE	A	B	C	E	F	G	H DIA	J	K	L	M	N	P	Q	R	S	T	U	V	W	X
CL-1-SWA-4	5/16-18	1-1/2	1	3/4	.88	3/4	2.39	1/2	2-1/4	5/32	.33	1/2	.25	1-1/4	#10 or M5	1-1/2	3/8	1/4	11/16	15/16	3/4	3/4
CL-4-SWA-4	1/2-13	2	1-3/8	1-1/8	.96	1-1/8	3.53	3/4	2-5/8	3/16	.44	11/16	.31	1-3/4	1/4 or M6	2	1/2	5/16	1	1-5/16	1-1/8	1
CL-5-SWA-4		2-1/2																				
CL-2-SWA-4	5/8-11	3	1-1/2	1-1/4	1.65	1-5/16	4.50	15/16	3	7/32	.58	1	.53	2-1/4	3/8 or M10	2-1/4	3/4	3/8	1-5/16	1-3/4	1-1/2	1-3/8
CL-3-SWA-4		4																				

ID CLAMPS

BODY: 1215 STEEL, BLACK OXIDE FINISH
 CENTER SCREW: ALLOY STEEL, BLACK OXIDE FINISH
 MOUNTING SCREWS: ALLOY STEEL, BLACK OXIDE FINISH

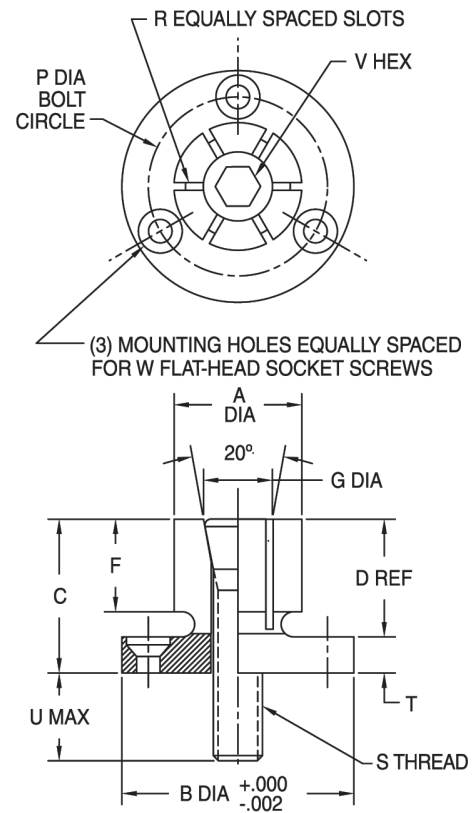
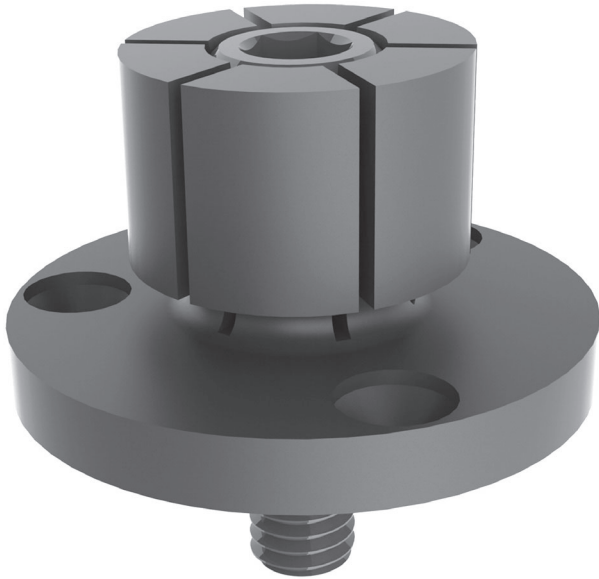

ID Clamps expand to self-center and clamp on the inside diameter of a workpiece, leaving the outside clear for machining. Tightening the tapered center screw with a hex wrench pushes the clamping segments outward, and slightly downward, to exert force on the workpiece's internal bore. These clamps are designed to have their outside diameter finish machined by the customer to suit the bore size, because maximum diameter expansion is limited (.006 to .025", depending on the size). ID Clamps allow close mounting for multi-part machining on vertical and horizontal machining centers. Available in seven sizes to hold any inside diameter from .26" to 2.06". Made in USA.

For maximum locational accuracy, machine a recess in the fixture base to fit exactly with the clamp's close-tolerance flange diameter. Flat-head mounting screws are furnished. Please note, ID Clamps provide mostly radial clamping force; therefore the workpiece must be firmly supported underneath – by resting directly on the clamp's mounting flange, the fixture base, or fixed rest pads.

Before finish machining the clamp's outside diameter on a lathe or milling machine, expand the clamp slightly (.002 - .003") from its relaxed diameter by tightening the tapered center screw. Secure with a jam nut if necessary. Reduce the outside diameter only as much as required to achieve smooth workpiece loading, always staying within the expansion range for that clamp size.

INCH

PART NO.	A DIA		B DIA	C	D	F	G DIA	P DIA	R	S	T	U	V	W	DIAMETER EXPANSION RANGE	RECOM-MENDED TORQUE (FT-LBS)	RADIAL HOLDING FORCE (LBS)
	BEFORE MACHINING	MINIMUM AFTER MACHINING															
CL-8-IDC	.500	.260	1.170	.86	.63	.57	.24	.825	4	#8-32	.230	.29	7/64	#6-32	.006	3.6	950
CL-9-IDC	.560	.370	1.240	.99	.76	.58	.36	.910	4	1/4-20	.230	.53	3/16	#6-32	.008	13	1900
CL-13-IDC	.813	.440	1.476	1.00	.77	.59	.43	1.140	6	5/16-18	.230	.60	1/4	#6-32	.010	28	2500
CL-18-IDC	1.125	.580	1.968	1.14	.90	.69	.57	1.550	6	3/8-16	.245	.77	5/16	#8-32	.014	49	4500
CL-22-IDC	1.390	.710	2.205	1.25	1.00	.81	.70	1.790	6	1/2-13	.250	.78	3/8	#8-32	.017	120	5900
CL-27-IDC	1.688	.910	2.736	1.56	1.25	1.06	.87	2.200	6	5/8-11	.310	.84	1/2	#10-32	.020	224	10000
CL-33-IDC	2.063	.910	2.972	1.56	1.25	1.06	.87	2.515	6	5/8-11	.310	.85	1/2	#10-32	.025	224	10000

ID CLAMPS

BODY: 1215 STEEL, BLACK OXIDE FINISH
CENTER SCREW: ALLOY STEEL, BLACK OXIDE FINISH
MOUNTING SCREWS: ALLOY STEEL, BLACK OXIDE FINISH

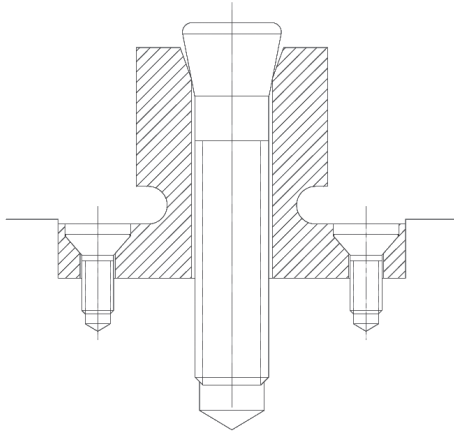

For maximum locational accuracy, machine a recess in the fixture base to fit exactly with the clamp's close-tolerance flange diameter. Flat-head mounting screws are furnished.



7

Each of these workpieces is clamped by two ID Clamps – a large clamp in the large bore and a small clamp in the slot. The large clamp is also the primary locator, so would be tightened first. The small clamp is also the secondary (radial or “clocking”) locator, so would be tightened second. By using ID Clamps, the workpiece’s entire outer surface is accessible for machining.

ACORN NUTS

1215 STEEL, CARBURIZED-HARDENED, BLACK OXIDE FINISH



Closed end covers the end of a stud to prevent snags or thread damage.

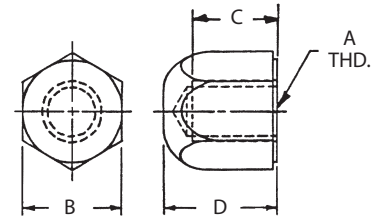
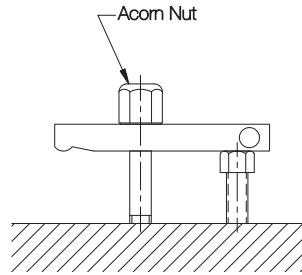

INCH

PART NO.	A	B	C	D
CL-0-AN	1/4-20	1/2	3/8	1/2
CL-1-AN	5/16-18	5/8	13/32	5/8
CL-5-AN	3/8-16	3/4	7/16	3/4
CL-2-AN	1/2-13	7/8	9/16	15/16
CL-3-AN	5/8-11	1-1/16	13/16	1-3/16
CL-4-AN	3/4-10	1-1/4	1	1-3/8

KNURLED NUTS

1215 STEEL, BLACK OXIDE FINISH



Heavy lock nut that can be tightened by hand or with an extension rod (1/4" or 6mm diameter). Large contact surface.

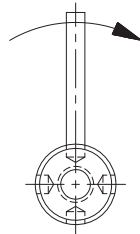

INCH

PART NO.	A	B DIA	C DIA	D	E	F DIA
CL-0-KN	1/4-20	1-1/8	1	7/16	1/16	.257
CL-00-KN	5/16-18					
CL-1-KN	3/8-16	1-3/8				
CL-2-KN	1/2-13					
CL-3-KN	5/8-11					

METRIC

CLM-6-KN	M6	28.5	25	11	1.6	6.5
CLM-8-KN	M8					
CLM-10-KN	M10					
CLM-12-KN	M12					
CLM-16-KN	M16	35				

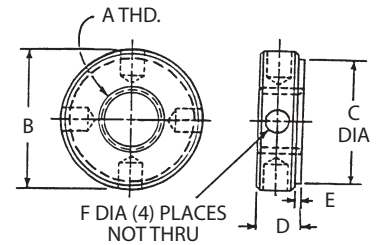

KNURLED CHECK NUTS

1215 STEEL, BLACK OXIDE FINISH



Multipurpose lock nut for finger tightening.

INCH

PART NO.	A	B DIA	C DIA	D	E
CL-1024-TSJN	#10-24	3/4	1/2	1/4	3/16
CL-1032-TSJN	#10-32			5/16	1/4
CL-1420-TSJN	1/4-20				
CL-51618-TSJN	5/16-18	1	3/4	3/8	1/4
CL-3816-TSJN	3/8-16				
CL-1213-TSJN	1/2-13				
CL-5811-TSJN	5/8-11				

METRIC

CLM-5-TSJN	M5	19	13	6	5
CLM-6-TSJN	M6			8	7
CLM-8-TSJN	M8				
CLM-10-TSJN	M10				
CLM-12-TSJN	M12	25	19	10	8
CLM-16-TSJN	M16				

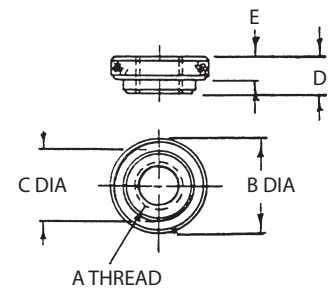

HEX NUTS

STEEL: MILD STEEL, BLACK OXIDE FINISH
 STAINLESS STEEL: 300-SERIES, PASSIVATE FINISH

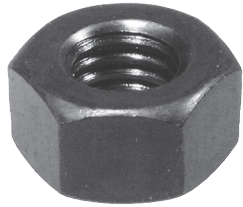

High-quality heavy Hex Nut, available in steel or stainless steel.

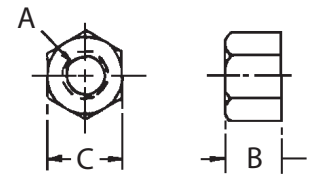

INCH

STEEL PART NO.	STAINLESS STEEL PART NO.	A THREAD	B	C
CL-4-HN	CL-4-HN-S	1/4-20	15/64	1/2
CL-5-HN	CL-5-HN-S	5/16-18	19/64	9/16
CL-6-HN	CL-6-HN-S	3/8-16	23/64	11/16
CL-8-HN	CL-8-HN-S	1/2-13	31/64	7/8
CL-10-HN	CL-10-HN-S	5/8-11	39/64	1-1/16
CL-12-HN	CL-12-HN-S	3/4-10	47/64	1-1/4
CL-14-HN	—	7/8-9	55/64	1-7/16
CL-16-HN	—	1"-8	63/64	1-5/8
CL-20-HN	—	1-1/4"-7	1-7/32	2

INCH FINE

STEEL PART NO.	STAINLESS STEEL PART NO.	A THREAD	B	C
CL-4-FHN	CL-4-FHN-S	1/4-28	7/32	7/16
CL-5-FHN	CL-5-FHN-S	5/16-24	17/64	1/2
CL-6-FHN	CL-6-FHN-S	3/8-24	21/64	9/16
CL-8-FHN	CL-8-FHN-S	1/2-20	7/16	3/4
CL-10-FHN	—	5/8-18	35/64	15/16
CL-12-FHN	—	3/4-16	41/64	1-1/8

METRIC

STEEL PART NO.	STAINLESS STEEL PART NO.	A THREAD	B	C
CLM-6-HN	—	M6	.20	10mm
CLM-8-HN	—	M8	.26	13mm
CLM-10-HN	—	M10	.31	17mm
CLM-12-HN	—	M12	.39	19mm
CLM-16-HN	—	M16	.51	24mm
CLM-20-HN	—	M20	.63	30mm
CLM-24-HN	—	M24	.75	36mm
CLM-30-HN	—	M30	.94	46mm

7

JAM NUTS

STEEL: MILD STEEL, BLACK OXIDE FINISH
 STAINLESS STEEL: 300-SERIES, PASSIVATE FINISH



High-quality heavy Jam Nut, available in steel or stainless steel.

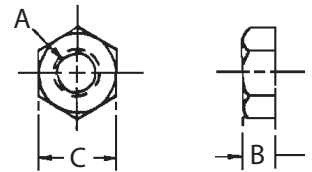

INCH

STEEL PART NO.	STAINLESS STEEL PART NO.	A THREAD	B	C
—	CL-2-JN-S	#8-32	1/8	11/32
—	CL-3-JN-S	#10-24	1/8	3/8
CL-4-JN	CL-4-JN-S	1/4-20	11/64	1/2
CL-5-JN	CL-5-JN-S	5/16-18	13/64	9/16
CL-6-JN	CL-6-JN-S	3/8-16	15/64	11/16
CL-8-JN	—	1/2-13	19/64	7/8
CL-10-JN	—	5/8-11	23/64	1-1/16
CL-12-JN	—	3/4-10	27/64	1-1/4
CL-14-JN	—	7/8-9	31/64	1-7/16
CL-16-JN	—	1"-8	35/64	1-5/8

INCH FINE

STEEL PART NO.	STAINLESS STEEL PART NO.	A THREAD	B	C
CL-3-FJN	CL-3-FJN-S	#10-32	1/8	3/8
CL-4-FJN	CL-4-FJN-S	1/4-28	5/32	7/16
CL-5-FJN	CL-5-FJN-S	5/16-24	3/16	1/2
CL-6-FJN	CL-6-FJN-S	3/8-24	7/32	9/16

METRIC

STEEL PART NO.	STAINLESS STEEL PART NO.	A THREAD	B	C
—	CLM-4-JN-S	M4	.08	7mm
—	CLM-5-JN-S	M5	.10	8mm
CLM-6-JN	CLM-6-JN-S	M6	.13	10mm
CLM-8-JN	CLM-8-JN-S	M8	.16	13mm
CLM-10-JN	CLM-10-JN-S	M10	.20	17mm
CLM-12-JN	CLM-12-JN-S	M12	.24	19mm
CLM-16-JN	CLM-16-JN-S	M16	.31	24mm
CLM-20-JN	CLM-20-JN-S	M20	.39	30mm
CLM-24-JN	—	M24	.47	36mm

FLANGE NUTS

STEEL: 1215, CARBURIZED-HARDENED, BLACK OXIDE FINISH
 STAINLESS STEEL: 300-SERIES, PASSIVATE FINISH



Flanged face provides a large bearing surface to avoid damaging the part underneath, especially when clamping over a slot. Precision machined from one solid piece of steel for extra strength.

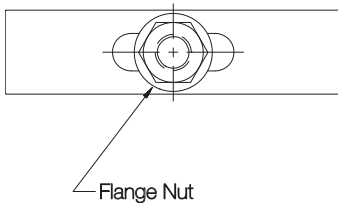

INCH

STEEL PART NO.	STAINLESS STEEL PART NO.	A	B	C DIA	D	E
—	CL-123	#10-24	5/16	1/2	3/8	.08
—	CL-125	1/4-20	5/16	9/16	7/16	.12
CL-1-FN	—			5/8	1/2	
—	CL-126	5/16-18	3/8	11/16	9/16	.09
CL-9-FN	—			3/4		.12
CL-2-FN	CL-127	3/8-16	1/2	7/8	11/16	.12
CL-3-FN	CL-128	1/2-13	11/16	1-1/8	7/8	.20
CL-4-FN	CL-129	5/8-11	13/16	1-3/8	1-1/16	
CL-5-FN	—	3/4-10	1	1-5/8	1-1/4	.25
CL-6-FN	—	7/8-9	1-1/8	1-3/4	1-7/16	.32
CL-7-FN	—	1"-8	1-1/4	2	1-5/8	.28
CL-10-FN	—	1-1/4"-7	1-3/8	2-1/4	1-13/16	.25

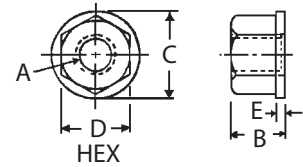

INCH FINE

—	CL-124	#10-32	5/16	1/2	3/8	.08
CL-1-FFN	—	1/4-28		5/8	1/2	.12
CL-2-FFN	—	3/8-24	1/2	7/8	11/16	.20
CL-3-FFN	—	1/2-20	11/16	1-1/8	7/8	
CL-4-FFN	—	5/8-18	13/16	1-3/8	1-1/16	.25
CL-5-FFN	—	3/4-16	1	1-5/8	1-1/4	
CL-7-FFN	—	1"-14	1-1/4	2	1-5/8	.25

METRIC

CLM-8-FN	—	M8	.39	.75	13mm	.12
CLM-10-FN	—	M10	.51	.87	17mm	
CLM-12-FN	—	M12	.67	1.10	19mm	.20
CLM-16-FN	—	M16	.83	1.34	24mm	
CLM-20-FN	—	M20	.98	1.61	30mm	.24
CLM-24-FN	—	M24	1.26	2.01	36mm	.28

COUPLING NUTS

1215 STEEL, CARBURIZED-HARDENED, BLACK OXIDE FINISH



For joining two or more studs together to create an extra-long stud.

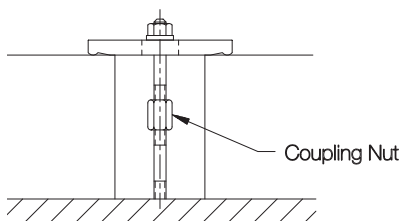

INCH

PART NO.	A	B	C
CL-0-CN	1/4-20	1/2	5/8
CL-00-CN	5/16-18	9/16	7/8
CL-1-CN	3/8-16	11/16	1
CL-2-CN	1/2-13	7/8	1-1/4
CL-3-CN	5/8-11	1-1/16	1-5/8
CL-4-CN	3/4-10	1-1/4	1-7/8
CL-6-CN	1"-8	1-5/8	2-1/2

METRIC

CLM-8-CN	M8	13mm	.79
CLM-10-CN	M10	17mm	.98
CLM-16-CN	M16	24mm	1.57
CLM-20-CN	M20	30mm	1.97

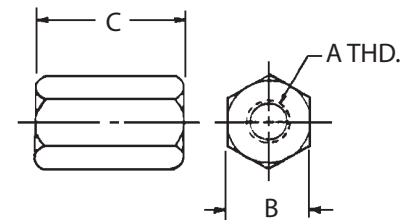

SPHERICAL NUTS AND WASHERS

STEEL: 1215, CARBURIZED-HARDENED, BLACK OXIDE FINISH
 STAINLESS STEEL: 300-SERIES, PASSIVATED



Combination nut and washer that compensates whenever a stud and clamp strap are not perpendicular. The nut has a convex spherical radius, while the washer has a matching concave spherical radius.

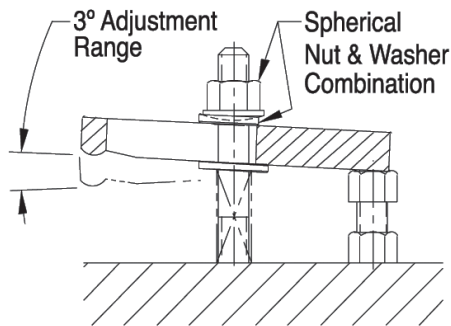
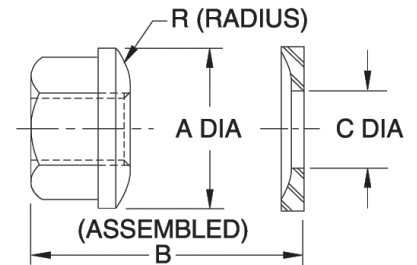

STEEL (INCH)

PART NO.	THREAD	HEX	A DIA	B	C DIA	R
CL-1-SNW	1/4-20	1/2	5/8	15/32	5/16	3/4
CL-9-SNW	5/16-18	9/16	3/4	17/32	3/8	1
CL-2-SNW	3/8-16	11/16	7/8	19/32	7/16	1-1/4
CL-3-SNW	1/2-13	7/8	1-1/8	7/8	9/16	1-1/2
CL-4-SNW	5/8-11	1-1/16	1-3/8	1	11/16	1-3/4
CL-5-SNW	3/4-10	1-1/4	1-5/8	1-3/16	7/8	2-1/4
CL-6-SNW	7/8-9	1-7/16	1-3/4	1-5/16	1	2-1/2
CL-7-SNW	1"-8	1-5/8	2	1-7/16	1-1/8	2-3/4

STAINLESS STEEL (INCH)

PART NO.	THREAD	HEX	A DIA	B	C DIA	R
CL-1-SNW-S	1/4-20	1/2	5/8	15/32	5/16	3/4
CL-9-SNW-S	5/16-18	9/16	3/4	17/32	3/8	1
CL-2-SNW-S	3/8-16	11/16	7/8	19/32	7/16	1-1/4
CL-3-SNW-S	1/2-13	7/8	1-1/8	7/8	9/16	1-1/2
CL-4-SNW-S	5/8-11	1-1/16	1-3/8	1	11/16	1-3/4
CL-5-SNW-S	3/4-10	1-1/4	1-5/8	1-3/16	7/8	2-1/4

STEEL (METRIC)

PART NO.	THREAD	HEX	A DIA	B	C DIA	R
CLM-6-SNW	M6	10mm	16	12	8	19
CLM-8-SNW	M8	13mm	19	14	9.5	25.5
CLM-10-SNW	M10	17mm	22	17	11	32
CLM-12-SNW	M12	19mm	28.5	22	14.5	38
CLM-16-SNW	M16	24mm	35	25	17.5	44.5
CLM-20-SNW	M20	30mm	41.5	30	22	57
CLM-24-SNW	M24	36mm	51	36	28.5	70

SPHERICAL WASHERS

STEEL: 1215, CARBURIZED-HARDENED, BLACK OXIDE FINISH
 STAINLESS STEEL: 300-SERIES, PASSIVATED



Two-piece washer that compensates whenever a stud and clamp strap are not perpendicular. The top washer has a convex spherical radius, while the bottom washer has a matching concave spherical radius.

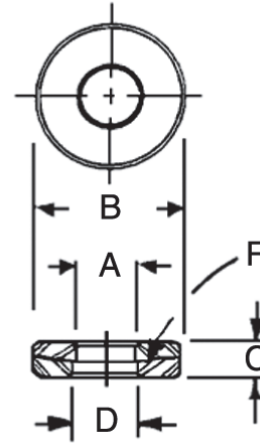

7

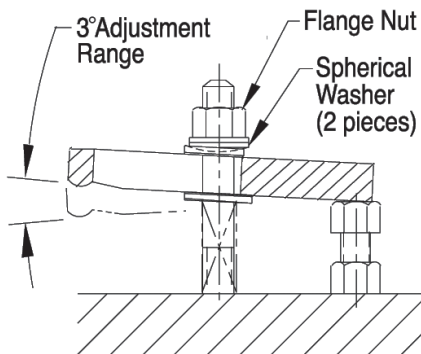

STEEL

PART NO.	BOLT SIZE	A DIA	B DIA	C	D DIA	R
CL-1-SW	1/4 & M6	9/32	5/8	3/16	5/16	3/4
CL-11-SW	5/16 & M8	11/32	3/4	1/4	3/8	1
CL-2-SW	3/8 & M10	13/32	7/8	1/4	7/16	1-1/4
CL-3-SW	1/2 & M12	17/32	1-1/8	5/16	9/16	1-1/2
CL-4-SW	5/8 & M16	21/32	1-3/8		11/16	1-3/4
CL-5-SW	3/4 & M18	25/32	1-5/8	3/8	7/8	2-1/4
CLM-20-SW	M20	.83			7/8	
CL-6-SW	7/8 & M22	15/16	1-3/4	1/2	1	2-1/2
CL-7-SW	1 & M24	1-1/16	2		1-1/8	2-3/4
CL-8-SW	1-1/8	1-3/16	2-1/4	1/2	1-1/4	3
CL-9-SW	1-1/4 & M30	1-5/16	2-5/8		1-3/8	
CL-10-SW	1-1/2 & M36	1-9/16	2-7/8		1-5/8	

STAINLESS STEEL

PART NO.	BOLT SIZE	A DIA	B DIA	C	D DIA	R
CL-144	#10 & M5	7/32	1/2	1/8	1/4	3/4
CL-145	1/4 & M6	9/32	5/8	3/16	5/16	
CL-146	5/16 & M8	11/32	13/16	7/32	3/8	1
CL-147	3/8 & M10	13/32	1	1/4	7/16	1-1/4
CL-148	1/2 & M12	17/32	1-1/8	5/16	9/16	1-1/2
CL-149	5/8 & M16	21/32	1-3/8		11/16	1-3/4
CL-150	3/4 & M18	25/32	1-5/8	3/8	7/8	2-1/4

FLAT WASHERS

STEEL: 1010, CARBURIZED-HARDENED, BLACK OXIDE FINISH
 STAINLESS STEEL: 300-SERIES



Thick, heavy-duty washer with both faces held flat and parallel. Available in steel or stainless steel.

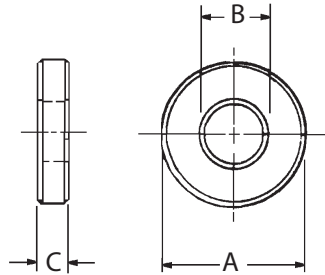

INCH & METRIC

STEEL PART NO.	STAINLESS STEEL PART NO.	BOLT SIZE	A DIA	B DIA	C
—	CL-254	#10 or M5	7/16	7/32	5/64
—	CL-255	1/4 or M6	1/2	9/32	5/64
CL-7-FW	—		5/8		1/8
—	CL-256	5/16 or M8	5/8	11/32	3/32
CL-14-FW	—		3/4		1/8
—	CL-257	3/8 or M10	3/4	13/32	3/32
CL-1-FW	—		7/8		1/8
CL-8-FW	—		1		3/16
CL-2-FW	—	1/2 or M12	1-1/8	17/32	1/8
CL-9-FW	CL-258				3/16
CL-3-FW	—	5/8 or M16	1-3/8	21/32	1/8
CL-10-FW	CL-259				3/16
CL-4-FW	—	3/4 or M18	1-5/8	25/32	5/32
CL-11-FW	CL-260				1/4
CLM-10-FW	—	M20	1-5/8	.827	1/4
CL-13-FW	—	7/8 or M22	1-3/4	29/32	1/4
CL-12-FW	—	1	2	1-1/32	9/32

KNURLED-FACE WASHERS

4130 STEEL, HEAT TREATED 125,000-140,000 PSI PER MIL-H-6875, ZINC PLATED YELLOW CHROMATE



Flat washer with a serrated face to prevent two parts from sliding in relation to each other. Close tolerance on washer ID prevents the stud from slipping.

Serrated Washers
Teeth Facing Inward

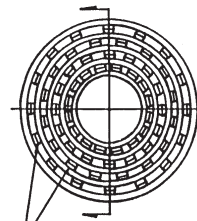
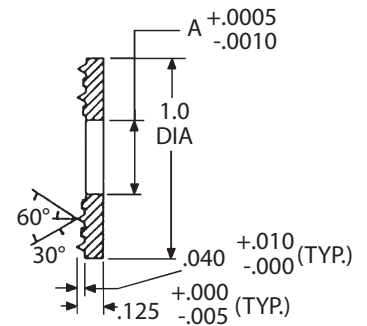
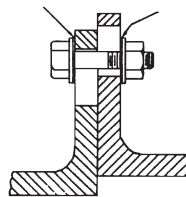

64 TEETH, 16 EQUALLY SPACED
ON EACH DIAMETER WITH
ALTERNATE ROWS STAGGERED

INCH

PART NO.	BOLT DIA	A DIA
CL-3-KFW	#10	.1935
CL-4-KFW	1/4	.2500

C WASHERS

STEEL: 1215, CARBURIZED-HARDENED, BLACK OXIDE FINISH
 STAINLESS STEEL: 300-SERIES

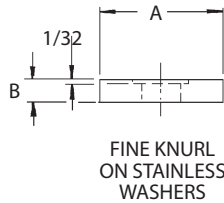
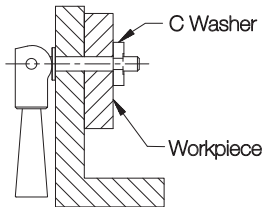
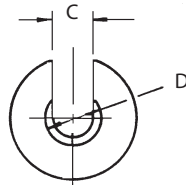

Washer that slides in and out of position for clear loading. Can be used with a nut, or by sliding it into a radial groove on a drawbar. Available in steel or stainless steel.

INCH & METRIC

STEEL PART NO.	STAINLESS STEEL PART NO.	BOLT SIZE	A DIA	B	C	D DIA
CL-1-CW	—	#10 or M5	1/2	3/16	13/64	11/32
CL-3-CW	—	1/4 or M6	3/4	1/4	17/64	13/32
—	CL-155		7/8	3/16	9/32	25/64
CL-5-CW	—	5/16 or M8	1	3/16	21/64	1/2
—	CL-157		1-1/4	5/16		5/8
CL-6-CW	—	3/8 or M10	1-1/4	3/8	13/32	23/32
CL-22-CW	—		1-3/4	1/4		23/32
CL-8-CW	—	1/2 or M12	1-7/8	3/8	17/32	29/32
CL-24-CW	—		2-1/4			
CL-9-CW	—	5/8 or M16	2-1/8	3/8	21/32	1-3/32
CL-26-CW	—		2-1/2	7/16		
CL-11-CW	—	3/4 or M18	2-1/2	7/16	25/32	1-9/32
CL-12-CW	—		2-1/2	7/16	1-1/32	1-21/32
CL-15-CW	—	1 or M24	1/2	1/2	1-1/32	1-21/32

7

SWING C WASHERS

1018 STEEL, CARBURIZED-HARDENED, BLACK OXIDE FINISH

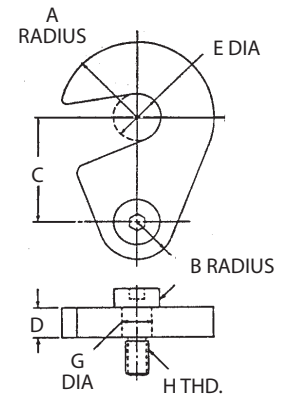
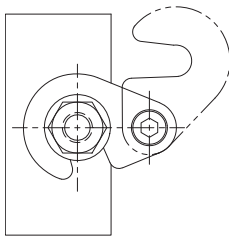
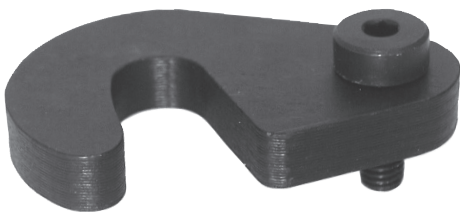

Permanently attached C washer that swings out of the way for clear loading. Can be reversed to swing into position either clockwise or counter-clockwise. Shoulder Screw furnished.

INCH

PART NO.	STUD SIZE	A	B	C	D	E DIA	G DIA	H	SHOULDER SCREW (FURNISHED)
CL-1-SCW	3/8	3/4	3/8	1	1/4	13/32	3/8	5/16-18	CL-24-SS
CL-2-SCW	1/2	1	1/2	1-1/4	3/8	17/32			CL-2-SS
CL-3-SCW	5/8	1-1/8	9/16	1-1/2	3/8	21/32	1/2	3/8-16	CL-3-SS
CL-4-SCW	3/4	1-1/4	5/8	1-3/4	1/2	13/16			CL-4-SS

METRIC

CLM-1-SCW	M10	19	9.5	25.5	6	10.5	10mm	M8	CLM-1006-SS
CLM-2-SCW	M12	25.5	12.5	32	9.5	13.5			CLM-1010-SS

CLAMPING STUDS

STEEL: 1144 STEEL, 100,000 PSI MIN. YIELD, 115,000 PSI MIN. TENSILE, BLACK OXIDE FINISH
 STAINLESS STEEL: 300 SERIES



High-strength general-purpose Clamping Stud, for use with a T Nut, or for installation directly into a fixture plate. Available in thread sizes from 1/4-20 to 1"-8 (M6 to M20 in metric), each in a choice of several lengths. Now also available in stainless steel, in 3/8-16, 1/2-13, and 5/8-11 thread sizes.

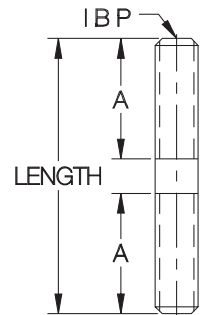

STEEL (INCH)

PART NO.	THREAD SIZE	LENGTH	A
CL-1/4-20X1.50-STUD	1/4-20	1.50	5/8
CL-1/4-20X2.00-STUD		2.00	7/8
CL-1/4-20X2.50-STUD		2.50	1
CL-1/4-20X3.00-STUD		3.00	
CL-1/4-20X3.50-STUD		3.50	
CL-1/4-20X4.00-STUD		4.00	
CL-5/16-18X1.50-STUD	5/16-18	1.50	9/16
CL-5/16-18X2.00-STUD		2.00	13/16
CL-5/16-18X2.50-STUD		2.50	1-1/16
CL-5/16-18X3.00-STUD		3.00	1-1/8
CL-5/16-18X3.50-STUD		3.50	
CL-5/16-18X4.00-STUD		4.00	
CL-5/16-18X6.00-STUD	6.00		
CL-3/8-16X1.50-STUD	3/8-16	1.50	9/16
CL-3/8-16X2.00-STUD		2.00	13/16
CL-3/8-16X2.50-STUD		2.50	1-1/16
CL-3/8-16X3.00-STUD		3.00	1-1/4
CL-3/8-16X3.50-STUD		3.50	
CL-3/8-16X4.00-STUD		4.00	
CL-3/8-16X4.50-STUD		4.50	
CL-3/8-16X5.00-STUD		5.00	
CL-3/8-16X5.50-STUD		5.50	
CL-3/8-16X6.00-STUD		6.00	
CL-3/8-16X7.00-STUD		7.00	
CL-3/8-16X8.00-STUD		8.00	
CL-1/2-13X2.00-STUD	1/2-13	2.00	
CL-1/2-13X2.50-STUD		2.50	1
CL-1/2-13X3.00-STUD		3.00	1-1/4
CL-1/2-13X3.50-STUD		3.50	1-1/2
CL-1/2-13X4.00-STUD		4.00	
CL-1/2-13X4.50-STUD		4.50	
CL-1/2-13X5.00-STUD		5.00	
CL-1/2-13X5.50-STUD		5.50	
CL-1/2-13X6.00-STUD		6.00	
CL-1/2-13X6.50-STUD		6.50	
CL-1/2-13X7.00-STUD		7.00	
CL-1/2-13X7.50-STUD		7.50	
CL-1/2-13X8.00-STUD	8.00		
CL-1/2-13X9.00-STUD	9.00	2	
CL-1/2-13X12.00-STUD	12.00		

STEEL (INCH) (Cont.)

PART NO.	THREAD SIZE	LENGTH	A
CL-5/8-11X2.50-STUD	5/8-11	2.50	15/16
CL-5/8-11X3.00-STUD		3.00	1-3/16
CL-5/8-11X3.50-STUD		3.50	1-7/16
CL-5/8-11X4.00-STUD		4.00	1-11/16
CL-5/8-11X4.50-STUD		4.50	1-3/4
CL-5/8-11X5.00-STUD		5.00	
CL-5/8-11X5.50-STUD		5.50	
CL-5/8-11X6.00-STUD		6.00	
CL-5/8-11X6.50-STUD		6.50	
CL-5/8-11X7.00-STUD		7.00	
CL-5/8-11X7.50-STUD		7.50	2
CL-5/8-11X8.00-STUD		8.00	
CL-5/8-11X9.00-STUD	9.00		
CL-5/8-11X10.00-STUD	10.00		
CL-5/8-11X12.00-STUD	12.00		
CL-5/8-11X14.00-STUD	14.00		
CL-3/4-10X3.00-STUD	3/4-10	3.00	1-1/8
CL-3/4-10X3.50-STUD		3.50	1-3/8
CL-3/4-10X4.00-STUD		4.00	1-5/8
CL-3/4-10X5.00-STUD		5.00	2
CL-3/4-10X6.00-STUD		6.00	
CL-3/4-10X7.00-STUD		7.00	
CL-3/4-10X8.00-STUD		8.00	
CL-3/4-10X9.00-STUD		9.00	
CL-3/4-10X10.00-STUD		10.00	
CL-3/4-10X12.00-STUD		12.00	
CL-7/8-9X5.00-STUD	7/8-9	5.00	2-1/16
CL-1-8X5.00-STUD	1"-8	5.00	2
CL-1-8X6.00-STUD		6.00	2-1/2
CL-1-8X8.00-STUD		8.00	
CL-1-8X10.00-STUD		10.00	

STAINLESS STEEL (INCH)

PART NO.	THREAD SIZE	LENGTH	A
CL-1/2-13X2.00-STUD-S	1/2-13	2.00	3/4
CL-1/2-13X3.00-STUD-S		3.00	1-1/4
CL-1/2-13X4.00-STUD-S		4.00	1-1/2
CL-1/2-13X5.00-STUD-S		5.00	

STEEL (METRIC)

PART NO.	THREAD SIZE	LENGTH	A	
CLM-6X-50-STUD	M6	1.97 (50mm)	.87	
CLM-6X-65-STUD		2.56 (65mm)	1.06	
CLM-8X-50-STUD	M8	1.97 (50mm)	.83	
CLM-8X-65-STUD		2.56 (65mm)	1.14	
CLM-8X-80-STUD	M10	3.15 (80mm)	1.22	
CLM-10X-50-STUD		1.97 (50mm)	.79	
CLM-10X-80-STUD		3.15 (80mm)	1.38	
CLM-10X-95-STUD		3.74 (95mm)		
CLM-10X-110-STUD		4.33 (110mm)		
CLM-10X-125-STUD		4.92 (125mm)		
CLM-10X-150-STUD		5.91 (150mm)		
CLM-10X-175-STUD		6.89 (175mm)		
CLM-10X-200-STUD		7.87 (200mm)		
CLM-12X-65-STUD		2.56 (65mm)		1.04
CLM-12X-80-STUD	3.15 (80mm)	1.34		
CLM-12X-95-STUD	3.74 (95mm)	1.54		
CLM-12X-110-STUD	4.33 (110mm)			
CLM-12X-125-STUD	4.92 (125mm)			
CLM-12X-150-STUD	5.91 (150mm)			
CLM-12X-175-STUD	6.89 (175mm)			
CLM-12X-200-STUD	7.87 (200mm)			
CLM-16X-80-STUD	M16	3.15 (80mm)	1.26	
CLM-16X-95-STUD		3.74 (95mm)	1.56	
CLM-16X-110-STUD		4.33 (110mm)	1.85	
CLM-16X-125-STUD		4.92 (125mm)		
CLM-16X-150-STUD		5.91 (150mm)		
CLM-16X-175-STUD		6.89 (175mm)		
CLM-16X-200-STUD		7.87 (200mm)		
CLM-20X-80-STUD		3.15 (80mm)		1.18
CLM-20X-95-STUD		3.74 (95mm)		1.48
CLM-20X-110-STUD		4.33 (110mm)		1.77
CLM-20X-125-STUD	4.92 (125mm)	2.07		
CLM-20X-150-STUD	5.91 (150mm)	2.17		
CLM-20X-175-STUD	6.89 (175mm)			
CLM-20X-200-STUD	7.87 (200mm)			

FIXTURE STUDS

300-SERIES STAINLESS STEEL, PASSIVATED



Stainless Steel

Fixture Studs have a thread-locking interference thread at the bottom end to install permanently in a fixture plate. These small sizes are designed specifically for mini-size stainless steel clamp straps. Available in thread sizes from #10-32 to 3/8-16, each in a choice of several lengths.

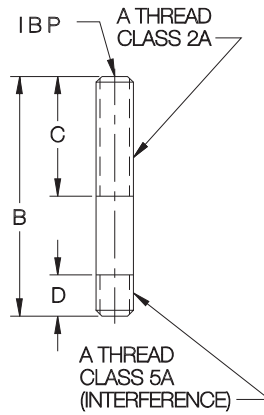

INCH

PART NO.	A	B	C	D
CL-11415	#10-32	1-1/2	3/4	7/32
CL-11515	1/4-20	1-1/2	5/8	9/32
CL-11520		2	3/4	
CL-11530		3	1	
CL-11615	5/16-18	1-1/2	5/8	11/32
CL-11620		2	1	
CL-11625	3/8-16	2-1/2	1-1/4	11/32
CL-11715		1-1/2	3/4	
CL-11725		2-1/2	1-1/4	
CL-11730		3	1-3/8	
CL-11740		4	1-1/2	

The Best Bushing Selection is at Carr Lane Mfg.

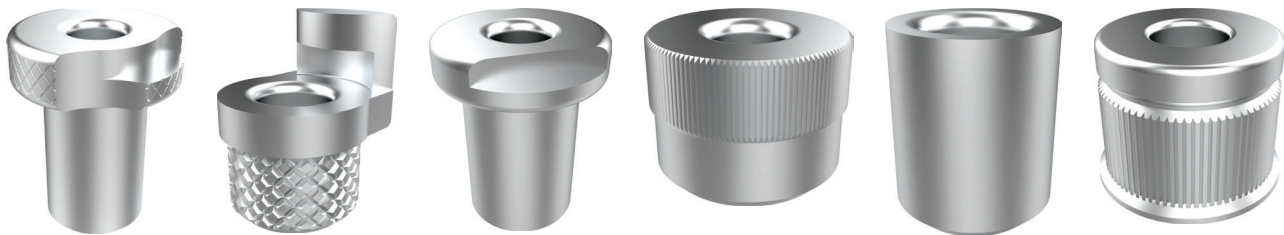

Carr Lane
MANUFACTURING CO.

See page 515 for more information

T NUTS

STEEL: MILD STEEL, CARBURIZED-HARDENED, BLACK OXIDE FINISH
 STAINLESS: 300-SERIES STAINLESS STEEL, PASSIVATED

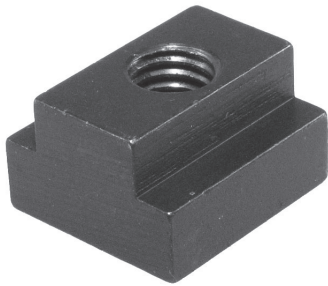

Sizes for all standard machine tables. Safety-stop feature prevents breaking the machine-table slot. Threads stop one short of going through T Nut to prevent a stud from jacking the nut out of the table.

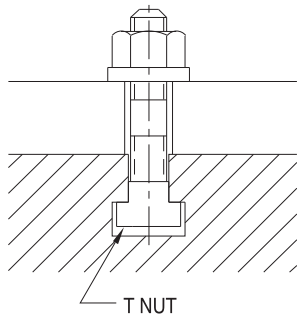

STEEL (METRIC)

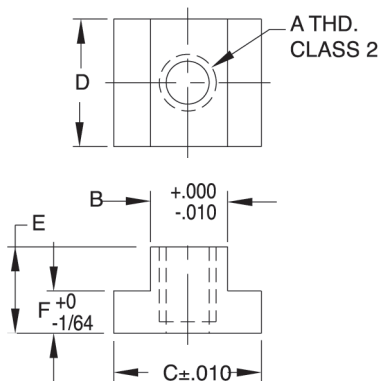

STEEL (INCH)

PART NO.	TABLE SLOT SIZE	A	B	C	D	E	F				
CL-26-TN	5/16 or 8mm	1/4-20	.307	9/16	9/16	1/4	3/16				
CL-18-TN	3/8 or 10mm	1/4-20	.370	5/8	7/8	7/16	7/32				
CL-19-TN		5/16-18									
CL-20-TN	7/16	5/16-18	.432	11/16	7/8	1/2					
CL-00-TN		3/8-16									
CL-12-TN	12mm	3/8-16	.467	3/4	3/4	1/2	17/64				
CL-21-TN	1/2	5/16-18	.495	7/8	7/8	1/2	9/32				
CL-0-TN		3/8-16									
CL-1-TN	9/16 or 14mm	3/8-16	.550		7/8	7/8	1/2	5/16			
CL-9-TN		1/2-13									
CL-16-TN	5/8 or 16mm	3/8-16	.620	1	1-1/8	5/8	11/32				
CL-2-TN		1/2-13									
CL-3-TN	11/16 or 18mm	1/2-13	.682	1-1/8	1-1/4	3/4	7/16				
CL-10-TN		5/8-11						.682	1-1/4	3/4	7/16
CL-10A-TN								.675			
CL-17-TN	3/4	1/2-13	.745	1-1/4	1-1/4	3/4	15/32				
CL-4-TN		5/8-11									
CL-14-TN	20mm	5/8-11	.782	1-1/4	1-1/4	7/8					
CL-5-TN	13/16	5/8-11	.807					1-1/4	1-1/2	1	9/16
CL-11-TN		3/4-10									
CL-15-TN	22mm	3/4-10	.861	1-1/4	1-1/2	1	1/2				
CL-6-TN	7/8	3/4-10	.870	1-1/2			9/16				
CL-7-TN	1	3/4-10	.995	1-5/8	1-3/4	1	5/8				
CL-22-TN		7/8-9									
CL-8-TN	1-1/16	3/4-10	1.057	1-5/8	2	1-1/8	11/16				
CL-23-TN		7/8-9									
CL-24-TN	1-1/8	7/8-9	1.120	1-3/4	2	1-1/2	3/4				
CL-25-TN		1"-8									

STAINLESS STEEL (INCH)

PART NO.	TABLE SLOT SIZE	A	B	C	D	E	F
CL-00-STN	7/16	3/8-16	.432	11/16	7/8	1/2	7/32
CL-0-STN	1/2		.495	7/8	7/8	1/2	9/32
CL-1-STN	9/16 or 14mm	3/8-16	.550	7/8	7/8	1/2	5/16
CL-9-STN		1/2-13					
CL-2-STN	5/8 or 16mm	1/2-13	.620	1	1-1/8	5/8	11/32
CL-3-STN	11/16 or 18mm	1/2-13	.682	1-1/8	1-1/4	3/4	7/16
CL-10-STN		5/8-11					

PART NO.	TABLE SLOT SIZE	A THREAD	THREAD PITCH (mm)	B (mm)	C (mm)	D (mm)	E (mm)	F (mm)
CLM-26-TN	5/16" or 8mm	M6	1	7.80	13	13	10	6
CLM-18-TN	3/8" or 10mm			M8	1.25	9.40	15.9	22
CLM-19-TN		12mm	M10			1.5	11.86	19
CLM-00-TN	1/2"			12.57	22.2		22	7.1
CLM-1-TN	9/16" or 14mm	M12	1.75	13.87		28.5		32
CLM-9-TN				5/8" or 16mm	15.75		8.7	
CLM-2-TN	11/16" or 18mm	M16	2	17.32	31.8	38	19	11.1
CLM-3-TN				20mm				19.86
CLM-10-TN	13/16"	M20	2.5	20.50	21.87	25.5	22	14.3
CLM-4-TN	22mm			12.7				

T NUT & STUD SETS

INFO+: SEE PAGES 305, 310 AND 312 FOR MATERIAL SPECIFICATIONS

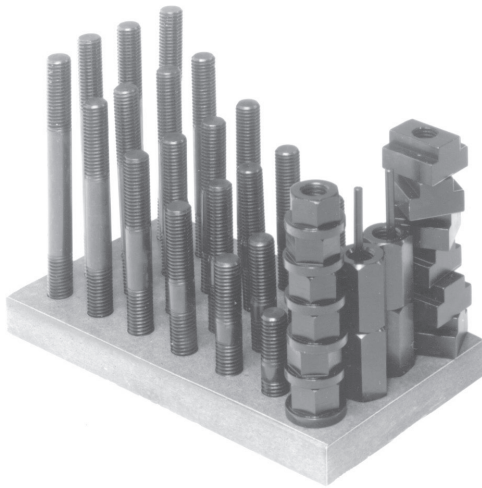

40-piece set includes a complete range of stud lengths with matching T Nuts, Flange Nuts, and Coupling Nuts — all mounted in a handy wooden holder.

Set includes:

- (4) Studs of each length 3", 4", 5", 6", 7", 8", or 80, 95, 125, 150, 175, 200mm
- (6) T Nuts
- (6) Flange Nuts
- (4) Coupling Nuts
- (1) Handy Holder

INCH

PART NO.	TABLE SLOT SIZE	STUDS (24)	T NUTS (6)	FLANGE NUTS (6)	COUPLING NUTS (4)	HOLDER (1)
CL-1-TNS	7/16	3/8-16	CL-00-TN	CL-2-FN	CL-1-CN	CL-1-TNH
CL-14-TNS	12mm		CL-12-TN			
CL-2-TNS	1/2		CL-0-TN			
CL-3-TNS	9/16 or 14mm	3/8-16	CL-1-TN	CL-2-FN	CL-1-CN	CL-1-TNH
CL-4-TNS		1/2-13	CL-9-TN	CL-3-FN	CL-2-CN	CL-2-TNH
CL-17-TNS	5/8 or 16mm	3/8-16	CL-16-TN	CL-2-FN	CL-1-CN	CL-1-TNH
CL-5-TNS		1/2-13	CL-2-TN	CL-3-FN	CL-2-CN	CL-2-TNH
CL-6-TNS	11/16 or 18mm	1/2-13	CL-3-TN	CL-3-FN	CL-2-CN	CL-2-TNH
CL-7-TNS		5/8-11	CL-10-TN	CL-4-FN	CL-3-CN	CL-3-TNH
CL-18-TNS	3/4	1/2-13	CL-17-TN	CL-3-FN	CL-2-CN	CL-2-TNH
CL-8-TNS		5/8-11	CL-4-TN	CL-4-FN	CL-3-CN	CL-3-TNH
CL-15-TNS	20mm	5/8-11	CL-14-TN	CL-4-FN	CL-3-CN	CL-3-TNH
CL-9-TNS	13/16		CL-5-TN			
CL-10-TNS	7/8	3/4-10	CL-11-TN	CL-5-FN	CL-4-CN	CL-4-TNH
CL-16-TNS		22mm	CL-15-TN	CL-5-FN	CL-4-CN	CL-4-TNH
CL-11-TNS	1	CL-6-TN				
CL-12-TNS	1-1/16	CL-7-TN				
CL-13-TNS		CL-8-TN				

METRIC

PART NO.	TABLE SLOT SIZE	STUDS (24)	T NUTS (6)	FLANGE NUTS (6)	COUPLING NUTS (4)	HOLDER (1)
CLM-1-TNS	12mm	M10	CLM-00-TN	CLM-10-FN	CLM-10-CN	CL-1-TNH
CLM-2-TNS	1/2		CLM-0-TN			
CLM-3-TNS	9/16 or 14mm	M10	CLM-1-TN	CLM-10-FN	CLM-10-CN	CL-1-TNH
CLM-4-TNS		M12	CLM-9-TN	CLM-12-FN	CLM-12-CN	CL-2-TNH
CLM-5-TNS	5/8 or 16mm	M12	CLM-2-TN	CLM-12-FN	CLM-12-CN	CL-2-TNH
CLM-6-TNS	11/16 or 18mm	M12	CLM-3-TN	CLM-12-FN	CLM-12-CN	CL-2-TNH
CLM-7-TNS		M16	CLM-10-TN	CLM-16-FN	CLM-16-CN	CL-3-TNH
CLM-8-TNS	20mm	M16	CLM-4-TN	CLM-16-FN	CLM-16-CN	CL-3-TNH
CLM-9-TNS	13/16		CLM-5-TN			
CLM-11-TNS	22mm	M20	CLM-6-TN	CLM-20-FN	CLM-20-CN	CL-4-TNH

T-SLOT CLEANERS

MILD STEEL, CARBURIZED-HARDENED, BLACK OXIDE FINISH

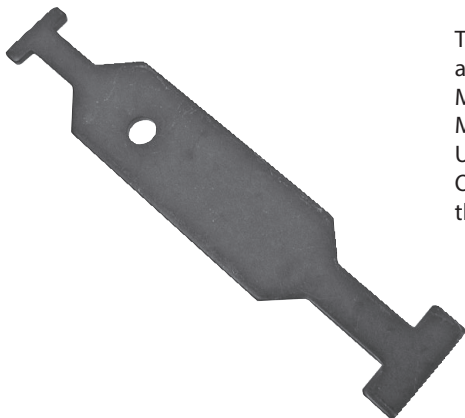

This handy tool is ideal for cleaning chips and debris out of machine-table T Slots. Much safer than blowing chips out with air. Made of heat treated steel, a full .109" thick. Use for any T Slot 3/8" (10mm) and above. One end is sized for smaller T Slots, while the other end is sized for larger T Slots.

PART NO.	OVERALL LENGTH	THICKNESS
CL-1-TSCL	6	.109

ROTARY T NUTS

ALLOY STEEL, RC 40-45, BLACK OXIDE FINISH

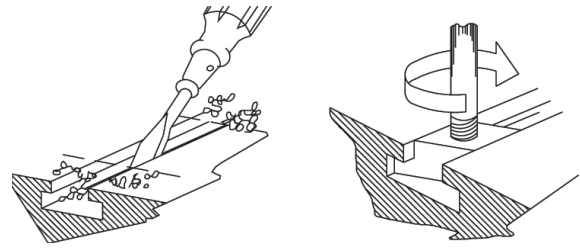
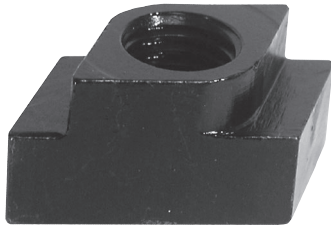

Rotary T Nuts can be inserted into the top of a T slot, unlike normal T Nuts, which must be inserted at the end of the slot. This allows adding T Nuts and Studs anywhere for a new setup, without tearing down any existing setups. Make sure that the area where the Rotary T Nut will be inserted is clear of debris, to allow the T Nut to rotate a full 60 degrees. Same safety-stop thread feature as standard T Nuts.

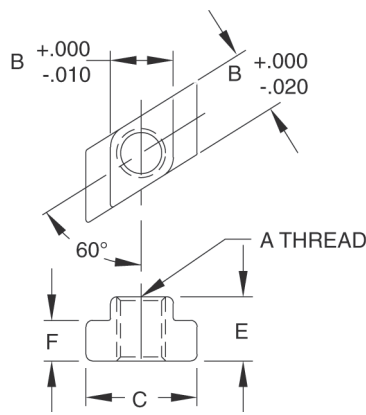

INCH

PART NO.	TABLE SLOT SIZE	A	B	C	E	F
CL-0-RTN	1/2	3/8-16	.495	7/8	1/2	9/32
CL-9-RTN	9/16	1/2-13	.560	7/8	5/8	11/32
CL-2-RTN	5/8 or 16mm	1/2-13	.620	1	5/8	11/32
CL-3-RTN	11/16 or 18mm	1/2-13	.682	1-1/8	3/4	7/16
CL-10-RTN		5/8-11				
CL-4-RTN	3/4 or 20mm	5/8-11	.745	1-1/4	3/4	15/32
CL-7-RTN	1	3/4-10	.995	1-5/8	1	5/8

METRIC

PART NO.	TABLE SLOT SIZE	A THREAD	THREAD PITCH (mm)	B (mm)	C (mm)	E (mm)	F (mm)
CLM-0-RTN	1/2"	M10	1.5	12.57	22	12.5	7
CLM-9-RTN	9/16" or 14mm	M12	1.75	13.97	22	16	8.5
CLM-2-RTN	5/8" or 16mm	M12	1.75	15.75	25.5	16	8.5
CLM-3-RTN	11/16" or 18mm	M12	1.75	17.32	28.5	19	11
CLM-10-RTN	11/16" or 18mm	M16	2	17.32	28.5	19	11
CLM-4-RTN	3/4" or 20mm	M16	2	18.92	32	19	12

ROTARY T NUT AND STUD SETS

INFO+: SEE PAGES 313, 318 AND 320 FOR MATERIAL SPECIFICATIONS

40-piece set includes a complete range of stud lengths with matching T Nuts, Flange Nuts, and Coupling Nuts — all mounted in a handy wooden holder. Set includes:

- (4) Studs of each length 3", 4", 5", 6", 7" and 8" (80, 95, 125, 150, 175, and 200mm in metric)
- (6) Rotary T Nuts
- (6) Flange Nuts
- (4) Coupling Nuts

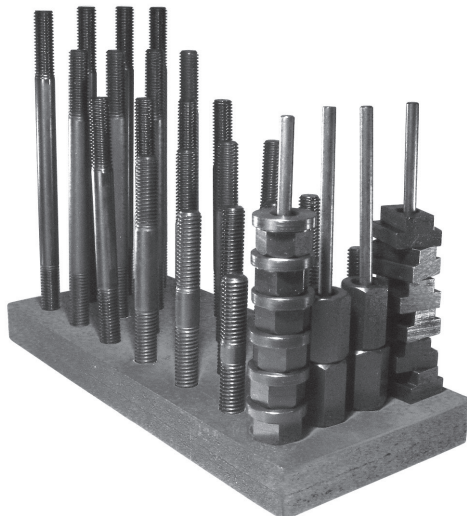

INCH

PART NO.	TABLE SLOT SIZE	STUDS (24)	ROTARY T NUTS (6)	FLANGE NUTS (6)	COUPLING NUTS (4)	HOLDER (1)
CL-2-RTNS	1/2	3/8-16	CL-0-RTN	CL-2-FN	CL-1-CN	CL-1-TNH
CL-4-RTNS	9/16 or 14mm	1/2-13	CL-9-RTN	CL-3-FN	CL-2-CN	CL-2-TNH
CL-5-RTNS	5/8 or 16mm	1/2-13	CL-2-RTN	CL-3-FN	CL-2-CN	CL-2-TNH
CL-6-RTNS	11/16 or 18mm	1/2-13	CL-3-RTN	CL-3-FN	CL-2-CN	CL-2-TNH
CL-7-RTNS		5/8-11	CL-10-RTN	CL-4-FN	CL-3-CN	CL-3-TNH
CL-8-RTNS	3/4 or 20mm	5/8-11	CL-4-RTN	CL-4-FN	CL-3-CN	CL-3-TNH
CL-12-RTNS	1	3/4-10	CL-7-RTN	CL-5-FN	CL-4-CN	CL-4-TNH

METRIC

CLM-2-RTNS	1/2	M10	CLM-0-RTN	CLM-10-FN	CLM-10-CN	CL-1-TNH
CLM-4-RTNS	9/16 or 14mm	M12	CLM-9-RTN	CLM-12-FN	CLM-12-CN	CL-2-TNH
CLM-5-RTNS	5/8 or 16mm	M12	CLM-2-RTN	CLM-12-FN	CLM-12-CN	CL-2-TNH
CLM-6-RTNS	11/16 or 18mm	M12	CLM-3-RTN	CLM-12-FN	CLM-12-CN	CL-2-TNH
CLM-7-RTNS		M16	CLM-10-RTN	CLM-16-FN	CLM-16-CN	CL-3-TNH
CLM-8-RTNS	3/4 or 20mm	M16	CLM-4-RTN	CLM-16-FN	CLM-16-CN	CL-3-TNH

FORGED T-BOLTS

FORGED MEDIUM CARBON STEEL, GRADE 8.8, RC 24-30, BLACK OXIDE



New item!

High-strength forged clamping bolt for T-slotted machine tables. Designed to provide full bearing with the slot to prevent twisting or jamming. Available in both Inch and Metric, each in a choice of several lengths.

FORGED T-BOLTS (INCH)

PART NO.	A SLOT WIDTH	B THREAD	C	D x E	F LENGTH	G
CL-6-DTSB-2.00	1/2"	3/8-16	0.31	0.87 x 0.87	1.97	1.38
CL-6-DTSB-2.50					2.56	1.57
CL-8A-DTSB-4.00		1/2-13			3.94	1.97
CL-8B-DTSB-3.15	3.15		2.17			
CL-10A-DTSB-4.00	5/8"	5/8-11	0.35	0.98 x 0.98	3.94	2.56
CL-10A-DTSB-6.30					6.30	3.94
CL-10B-DTSB-2.50	3/4"	3/4-10	0.39	1.10 x 1.10	2.56	1.77
CL-12A-DTSB-4.00					3.94	2.56
CL-12A-DTSB-6.25					6.30	3.94
CL-12B-DTSB-5.00	7/8"		0.55	1.38 x 1.38	4.92	3.35

FORGED T-BOLTS (METRIC)

CLM-12-DTSB-50	14	M12	8	22 x 22	50	35
CLM-12-DTSB-65					65	40
CLM-12-DTSB-100					100	50
CLM-16-DTSB-80	16	M16	9	25 x 25	80	55
CLM-16-DTSB-100					100	65
CLM-18-DTSB-65	18	M18	10	28 x 28	65	45
CLM-18-DTSB-100					100	65
CLM-18-DTSB-160					160	100
CLM-22-DTSB-125	22	M22	14	35 x 35	125	85

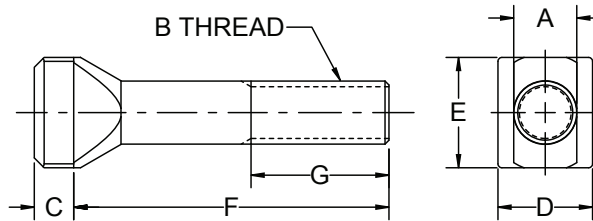
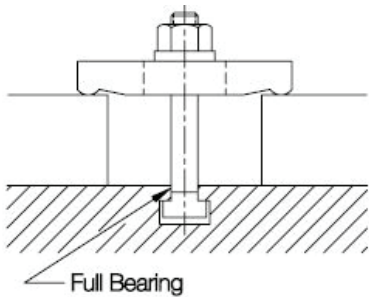

SHOULDER SCREWS

ALLOY STEEL, HEAT TREATED RC 32-43, BLACK OXIDE FINISH



Precision close-tolerance Shoulder Screw. Shoulder diameter is ground to a closer tolerance than ordinary stripper bolts for better bearing action. Shoulder length is held to a plus tolerance to allow a nominal-size plate to rotate freely underneath the head.

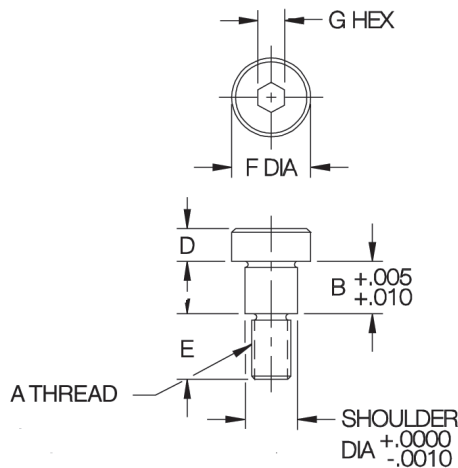
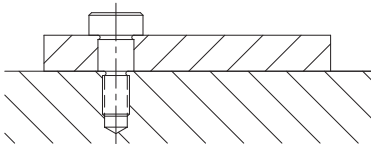

INCH

PART NO.	SHOULDER DIA		A	B		D	E	F DIA	G							
	NOMINAL	ACTUAL		NOMINAL	ACTUAL											
CL-5-SS	1/4	.2500	#10-24	1/4	.2500	3/16	3/8	3/8	1/8							
CL-12-SS				3/8	.3750											
CL-13-SS				1/2	.5000											
CL-37-SS				5/8	.6250											
CL-15-SS				3/4	.7500											
CL-16-SS				1	1.0000											
CL-1-SS	5/16	.3125	1/4-20	1/4	.2500	7/32	7/16	7/16	5/32							
CL-6-SS				5/16	.3125											
CL-11-SS				3/8	.3750											
CL-20-SS				1/2	.5000											
CL-21-SS				5/8	.6250											
CL-7-SS				3/4	.7500											
CL-8-SS	1	1.0000														
CL-24-SS	3/8	.3750	5-16-18	1/4	.2500	1/4	1/2	9/16	3/16							
CL-2-SS				3/8	.3750											
CL-14-SS				1/2	.5000											
CL-9-SS				5/8	.6250											
CL-10-SS				3/4	.7500											
CL-47-SS				1	1.0000											
CL-3-SS	1/2	.5000	3/8-16	3/8	.3750	5/16	5/8	3/4	1/4							
CL-4-SS				1/2	.5000											
CL-31-SS				5/8	.6250											
CL-32-SS				3/4	.7500											
CL-46-SS				1	1.0000											
CL-33-SS				5/8	.6250					1/2-13	1/2	.5000	3/8	3/4	7/8	5/16
CL-34-SS	5/8	.6250														
CL-35-SS	3/4	.7500														
CL-36-SS	1	1.0000														
CL-38-SS	3/4	.7500	5/8-11			1/2	.5000	1/2	7/8		1	3/8				
CL-39-SS						3/4	.7500									
CL-40-SS				1	1.0000											

METRIC

PART NO.	SHOULDER DIA (mm)	A THREAD	THREAD PITCH (mm)	B (mm)	D (mm)	E (mm)	F DIA (mm)	G (mm)
CLM-806-SS	8	M6	1	6	5.5	11	13	4
CLM-808-SS				8				
CLM-810-SS				10				
CLM-812-SS				12				
CLM-816-SS				16				
CLM-820-SS				20				
CLM-1006-SS	10	M8	1.25	6	7	13	16	5
CLM-1008-SS				8				
CLM-1010-SS				10				
CLM-1012-SS				12				
CLM-1016-SS				16				
CLM-1020-SS				20				
CLM-1310-SS	13	M10	1.5	10	9	16.5	18	6
CLM-1312-SS				12				
CLM-1316-SS				16				
CLM-1320-SS				20				
CLM-1610-SS	16	M12	1.75	10	11	18.5	24	8
CLM-1612-SS				12				
CLM-1616-SS				16				
CLM-1620-SS				20				
CLM-2016-SS	20	M16	2	16	14	22.5	30	10
CLM-2020-SS				20				
CLM-2025-SS				25				

SWING BOLTS

STEEL: 1144, 115,000 PSI MIN. TENSILE STRENGTH, 100,000 PSI MIN. YIELD STRENGTH, BLACK OXIDE FINISH



Shoulder-type Eye Bolt that can be used as a stationary hinge point. Reamed hole for smooth bearing.

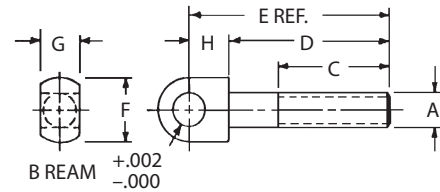

INCH

PART NO.	A	B DIA		C	D	E	F DIA	G		H
		NOMINAL	ACTUAL					NOMINAL	ACTUAL	
CL-00-SB	1/4-20	1/4	.250	3/4	1-3/16	1-1/2	1/2	5/16	.312	5/16
CL-0-SB	5/16-18	5/16	.312	1	1-5/8	2	5/8	3/8	.375	3/8
CL-1-SB	3/8-16	3/8	.375	1-3/8	2	2-1/2	3/4	1/2	.500	1/2
CL-2-SB	1/2-13	1/2	.500	1-3/4	2-1/2	3-1/8	1	5/8	.625	5/8
CL-2A-SB				2-1/4	3-1/2	4-1/8				
CL-3-SB	5/8-11	5/8	.625	1-3/4	2-3/4	3-1/2	1-1/4	3/4	.750	3/4
CL-3A-SB				2-1/2	4	4-3/4				

METRIC

PART NO.	THREAD	THREAD PITCH (mm)	B DIA (mm)	C (mm)	D (mm)	E (mm)	F DIA (mm)	G (mm)	H (mm)
CLM-00-SB	M6	1	6	20	30	40	12	8	10
CLM-0-SB	M8	1.25	8	25	40	50	16	10	15
CLM-1-SB	M10	1.5	10	35	50	65	20	12	15
CLM-2B-SB				45	65	80			
CLM-2C-SB	M12	1.75	12	55	90	105	24	14	15
CLM-3-SB				45	70	90			
CLM-3A-SB	M16	2	16	65	100	120	32	18	20

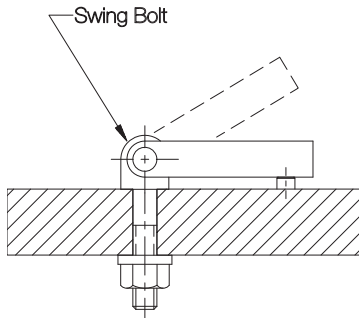

7

Tiny Vise® Edge Clamps

Don't let the small size fool you!



Strong, reliable clamping ideal for fixturing multiple parts

See page 281 for more information



EYE BOLTS

STEEL: 1144, 115,000 PSI MIN. TENSILE STRENGTH, 100,000 PSI MIN. YIELD STRENGTH, BLACK OXIDE FINISH
 STAINLESS STEEL: 300 SERIES

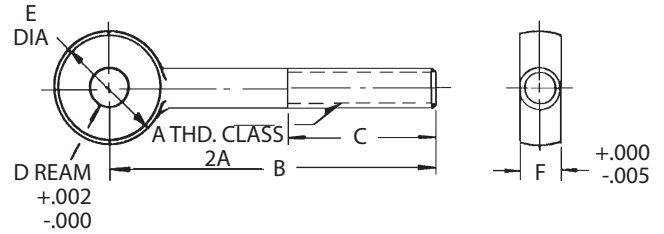

High-strength Eye Bolt with a reamed bearing hole. High-carbon steel, fully machined from solid barstock. Also available in stainless steel. Available in other lengths and materials as a special.

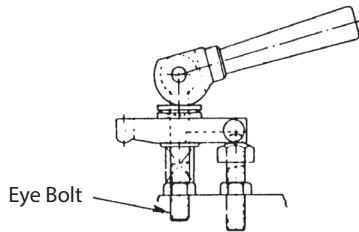

INCH

PART NO. STEEL	PART NO. STAINLESS STEEL	A	D DIA		B	C	E	F	
			NOMINAL	ACTUAL				NOMINAL	ACTUAL
CL-25-EB	CL-25-EB-S	1/4-20	3/16	.188	2	3/4	1/2	1/4	.250
CL-26-EB	CL-26-EB-S				3	1-1/4			
CL-31-EB	CL-31-EB-S	5/16-18	1/4	.250	3	1-1/2	5/8	5/16	.312
CL-32-EB	—				4	2			
CL-38-EB	—	3/8-16	5/16	.312	3	1-1/2	3/4	3/8	.375
CL-40-EB	CL-40-EB-S				3	1-1/2			
CL-37-EB	—	1/2-13	3/8	.375	3-3/4	2	1	1/2	.500
CL-50-EB	CL-50-EB-S				3-3/4	1-1/2			
CL-51-EB	CL-51-EB-S	5/8-11	5/8	.625	5	2	1-1/4	5/8	.625
CL-62-EB	—				4-1/2	2			
CL-63-EB	—	3/4-10	5/8	.625	6	2-1/2	1-1/2	3/4	.750
CL-75-EB	—				6	2-1/2			
CL-76-EB	—		3/4	.750	6	2-1/2			

METRIC

PART NO.	A THREAD	THREAD PITCH (mm)	D DIA (mm)	B (mm)	C (mm)	E (mm)	F (mm)
CLM-25A-EB	M6	1	6	50	20	12	6
CLM-26A-EB	M6	1	6	75	30	12	6
CLM-31A-EB	M8	1.25	8	75	40	16	8
CLM-32A-EB	M8	1.25	8	100	50	16	8
CLM-40-EB	M10	1.5	10	75	40	20	10
CLM-37-EB	M10	1.5	10	100	50	20	10
CLM-50A-EB	M12	1.75	12	100	40	24	12
CLM-51A-EB	M12	1.75	12	125	50	24	12
CLM-62-EB	M16	2	16	115	50	32	16
CLM-63-EB	M16	2	16	150	65	32	16
CLM-76A-EB	M20	2.5	20	150	65	40	20

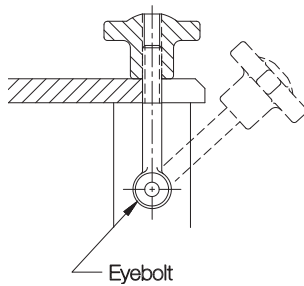

CAM HANDLES

1020 STEEL, CARBURIZED-HARDENED BLACK OXIDE FINISH

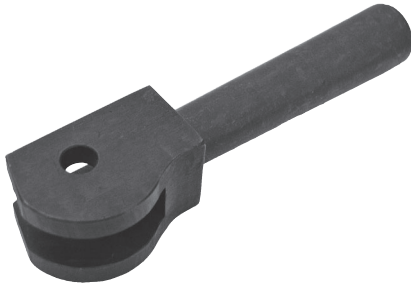

Straddle-type cam handle that can be used with an Eyebolt or custom-made drawbar. Continuous-rise spiral cam locks securely in any position. Available in six inch and five metric sizes.

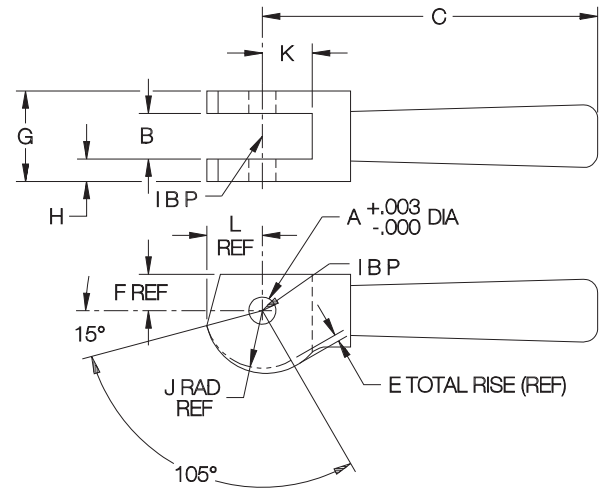

7

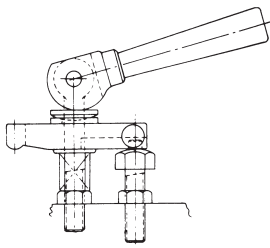

Double Cams are used with Eyebolts on Slotted-Heel Clamp Assemblies.

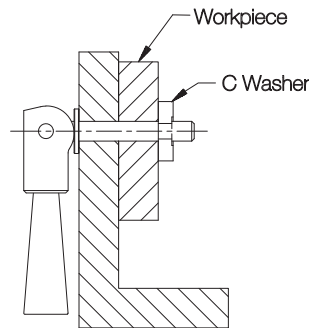

INCH

PART NO.	MATCHING EYEBOLT SIZE	A DIA		B		C	E	F	G	H	J	K	L	CLEVIS PIN REQD
		NOMINAL	ACTUAL	NOMINAL	ACTUAL									
CL-11-CH	1/4-20	3/16	.188	1/4	.266	2-17/32	.046	1/4	5/8	3/16	.40	.33	.38	CL-610-CLVP
CL-11A-CH	5/16-18	1/4	.250	5/16	.328					5/32				CL-810-CLVP
CL-12-CH	3/8-16	5/16	.313	3/8	.390	3-13/16	.062	5/16	7/8	1/4	.52	.54	.50	CL-1014-CLVP
CL-13-CH	1/2-13	3/8	.376	1/2	.516	4-5/8	.094	1/2	1-1/8	5/16	.79	.69	.76	CL-1218-CLVP
CL-14-CH	5/8-11	5/8	.626	5/8	.641	4-15/16	.109	9/16	1-1/4		.92	.85	.89	CL-2020-CLVP
CL-15-CH	3/4-10	5/8	.626	3/4	.766	5-1/8	.141	5/8	1-1/2	3/8	1.19	1.00	1.15	CL-2024-CLVP

METRIC

CLM-11-CH	M6	6mm	.237	6mm	.266	2-17/32	.046	1/4	5/8	3/16	.40	.33	.38	CLM-616-CLVP
CLM-12-CH	M10	10mm	.395	10mm	.409	3-13/16	.062	5/16	7/8	1/4	.52	.54	.50	CLM-1023-CLVP
CLM-13-CH	M12	12mm	.473	12mm	.516	4-5/8	.094	1/2	1-1/8	5/16	.79	.69	.76	CLM-1229-CLVP
CLM-15-CH	M20	20mm	.788	20mm	.803	5-1/8	.141	5/8	1-1/2	3/8	1.19	1.00	1.15	CLM-2038-CLVP

CLAMP RESTS

STEEL: 1215, CARBURIZED-HARDENED, BLACK OXIDE FINISH
STAINLESS STEEL: 300 SERIES



Steel

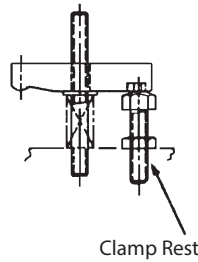

Rear support for Slotted-Heel Clamp Straps. Steel version has a hex head for adjustment, and is furnished with a Jam Nut. Stainless steel version has a drilled hole for turning with a rod.



Stainless Steel

STEEL (INCH)

PART NO.	A	C DIA	D	E	F	G
CL-1-CR	1/4-20	5/32	1/8	1/4	7/16	1-1/8
CL-1A-CR	5/16-18	7/32	3/16	5/16	1/2	1-11/16
CL-1A-CR						2-7/16
CL-2-CR	3/8-16	11/32	7/32	3/8	9/16	2-1/32
CL-3-CR						3-21/32
CL-4-CR	1/2-13	11/32	1/4	1/2	11/16	2-1/8
CL-4A-CR						3-5/8
CL-5-CR	5/8-11	15/32	1/4	5/8	7/8	2-3/8
CL-7-CR						3-5/8
CL-8-CR	3/4-10	15/32	1/4	5/8	1-1/16	2-1/2
CL-9-CR						3-5/8

STEEL (METRIC)

PART NO.	A THREAD	THREAD PITCH (mm)	C DIA (mm)	D (mm)	E (mm)	F (mm)	G (mm)
CLM-1-CR	M6	1	4	3	5	10	27
CLM-1A-CR	M8	1.25	5.5	4	8	13	45
CLM-2-CR							49
CLM-3-CR	M10	1.5	8.5	6	10	17	94
CLM-4-CR							54
CLM-4A-CR	M12	1.75	12	7	15	19	94
CLM-5-CR							54
CLM-7-CR	M16	2	12	7	15	24	94
CLM-8-CR							63
CLM-9-CR	M20	2.5	12	7	15	30	93

STAINLESS STEEL (INCH)

PART NO.	A	B	C	D DIA	E
CL-13410	#10-32	3/4	1	3/32	1/8
CL-13515	1/4-20	1-3/16	1-1/2	1/8	3/16
CL-13615	5/16-18	1-1/8	1-1/2	5/32	3/16
CL-13717	3/8-16	1-3/8	1-3/4	3/16	3/16

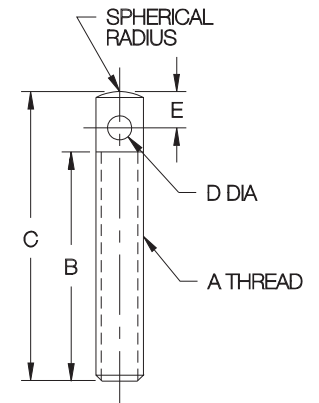
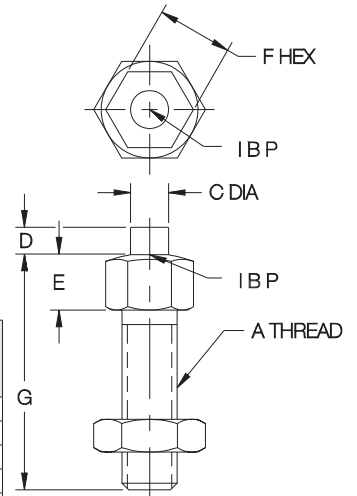

CLAMP REST SCREWS

STEEL: 1215, CARBURIZED-HARDENED, BLACK OXIDE FINISH



Rear support for Drill-Spot-Heel Clamp Straps.

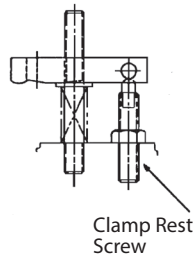

INCH

PART NO.	A	B	C DIA	D	E
CL-1-CRS	3/8-16	2	.250	.313	1/4
CL-2-CRS		2-12			
CL-3-CRS	1/2-13	3	.344	.313	3/8
CL-4-CRS		2			
CL-5-CRS	1/2-13	2-1/2			
CL-6-CRS		3			

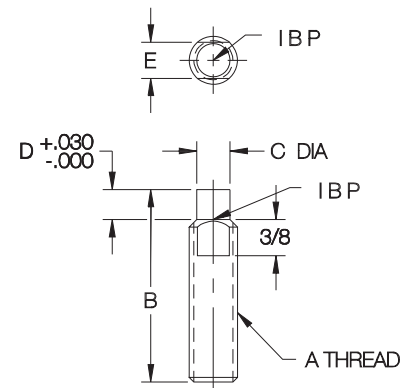

GUIDE BLOCKS

1018 STEEL, CARBURIZED-HARDENED, BLACK OXIDE FINISH

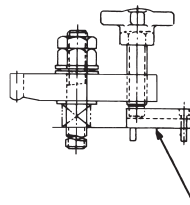
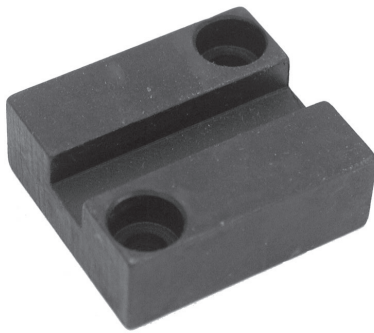

Guide Block

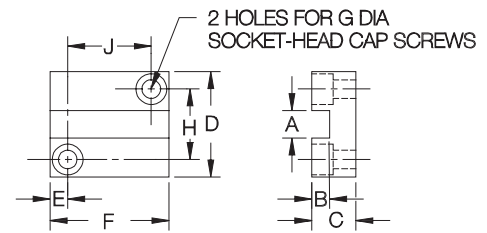

Rear slide block for Tapped-Heel Clamp Straps. Guides Clamp Strap straight back for loading.

PART NO.	CLAMP-STRAP STUD SIZE	A	B	C	D	E	F	G MOUNTING SCREWS	H	J
CL-2-GB	1/4-20 or M6	.198	.10	1/4	3/4	13/64	1-3/16	#6-32 or M4	15/32	25/32
CL-20-GB			.05							
CL-4-GB	3/8-16 or M10	.265	.20	1/2	1-1/8	7/32	2	#10-32 or M5	3/4	1-9/16
CL-40-GB			.08							
CL-6-GB	1/2-13 or M12	.390	.25	5/8	1-1/2	1/4	1-11/16	1/4-20 or M6	1	1-3/16
CL-60-GB			.12				1-5/8			
CL-8-GB	5/8-11 or M16	.515	.25	5/8	1-3/4	1/4	2-13/32	1/4-20 or M6	1-1/4	1-1/8
CL-80-GB			.15							
CL-11-GB	3/4-10 or M20	.540	.39	3/4	1-3/4	1/4	2-13/32	1/4-20 or M6	1-1/4	1-29/32
CL-110-GB			.18							

7

CLAMP SPRINGS

STEEL: SPRING STEEL, BLACK OXIDE FINISH
STAINLESS STEEL: 300-SERIES

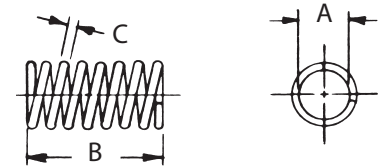
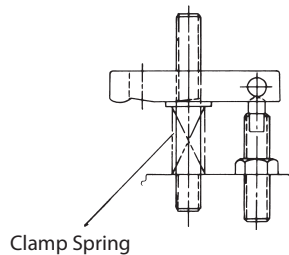

Sturdy spring that holds up a Clamp Strap for clear loading.

STEEL

PART NO.	FITS STUD SIZE	A DIA	B	C DIA	NO. OF COILS
CL-5-SPG	1/4-20 or M6	19/64	1-1/8	.062	7
CL-6-SPG	5/16-18 or M8	23/64	1-7/32		6
CL-7-SPG	3/8-16 or M10	7/16	1-9/16		8
CL-9-SPG	1/2-13 or M12	9/16	1-11/16	.091	7
CL-11-SPG	5/8-11 or M16	11/16	1-3/4		5
CL-13-SPG	3/4-10 or M20	13/16	2-1/2		6-1/2

STAINLESS STEEL

PART NO.	FITS STUD SIZE	A DIA	B	C DIA	NO. OF COILS
CL-2430.7	#10-32 or M5	13/64	.7	.042	5-1/2
CL-2440.7	1/4-20 or M6	17/64	.7		
CL-2450.7	5/16-18 or M8	21/64	.7	.049	5
CL-2461.0	3/8-16 or M10	13/32	1.0		

CLAMPING KITS

SEE CATALOG PAGE OF EACH COMPONENT FOR MATERIAL SPECIFICATIONS

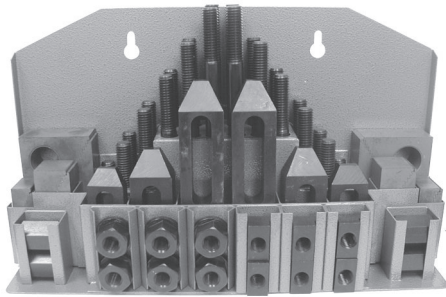

**Standard Blocks
Metal Holder**

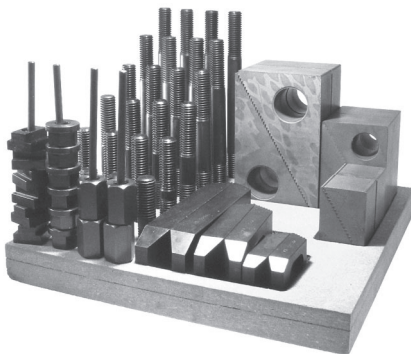

**Heavy Blocks
Wooden Holder**

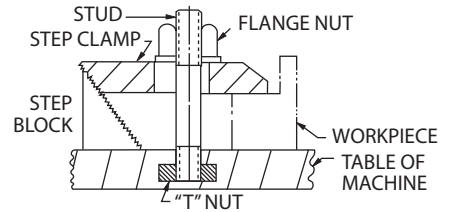

Economical Clamping Kit with a wide assortment of Step Clamps and Blocks. Fully machined from top-grade steel. Available with standard Step Blocks in a metal holder (for wall or machine mounting), or with wider heavy blocks in a wooden holder.

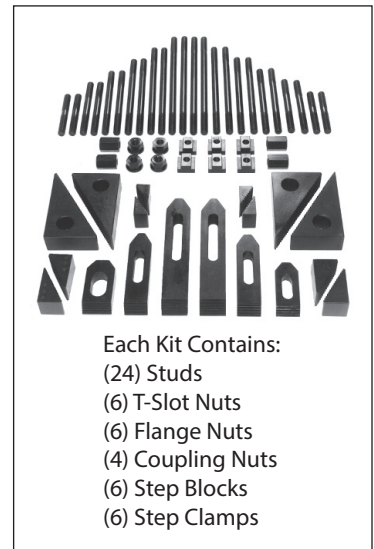

Each Kit Contains:
 (24) Studs
 (6) T-Slot Nuts
 (6) Flange Nuts
 (4) Coupling Nuts
 (6) Step Blocks
 (6) Step Clamps

STANDARD BLOCKS (INCH)

PART NO.	STUD SIZE	TABLE SLOT SIZE	T-NUT & STUD SET (1)	STEP CLAMPS (2) EACH	STEP BLOCK PAIRS (2) EACH	HOLDER (1)
CL-1-CK	3/8-16	7/16	CL-1-TNS	CL-32-STC CL-34-STC CL-36-STC	CL-10-BS CL-20-BS CL-30-BS	CL-1-CKMH
CL-20-CK		12mm	CL-14-TNS			
CL-2-CK		1/2	CL-2-TNS			
CL-3-CK		9/16 or 14mm	CL-3-TNS			
CL-24-CK	1/2-13	5/8 or 16mm	CL-17-TNS	CL-42-STC CL-44-STC CL-46-STC	CL-10-BS CL-20-BS CL-30-BS	CL-2-CKMH
CL-4-CK		9/16 or 14mm	CL-4-TNS			
CL-5-CK		5/8 or 16mm	CL-5-TNS			
CL-6-CK		11/16 or 18mm	CL-6-TNS			
CL-25-CK	5/8-11	3/4	CL-18-TNS	CL-52-STC CL-54-STC CL-56-STC	CL-10-BS CL-20-BS CL-30-BS	CL-3-CKMH
CL-7-CK		11/16 or 18mm	CL-7-TNS			
CL-8-CK		3/4	CL-8-TNS			
CL-21-CK		20mm	CL-15-TNS			
CL-9-CK		13/16	CL-9-TNS			

STANDARD BLOCKS (METRIC)

CLM-1-CK	M10	2mm	CLM-1-TNS	CL-32-STC	CL-10-BS	CL-1-CKMH
CLM-2-CK	M10	1/2	CLM-2-TNS	CL-34-STC	CL-20-BS	
CLM-3-CK		9/16 or 14mm	CLM-3-TNS	CL-36-STC	CL-30-BS	
CLM-4-CK	M12	9/16 or 14mm	CLM-4-TNS	CL-42-STC	CL-10-BS	CL-2-CKMH
CLM-5-CK		5/8 or 16mm	CLM-5-TNS	CL-44-STC	CL-20-BS	
CLM-6-CK		11/16 or 18mm	CLM-6-TNS	CL-46-STC	CL-30-BS	
CLM-7-CK	M16	11/16 or 18mm	CLM-7-TNS	CL-52-STC	CL-10-BS	CL-3-CKMH
CLM-8-CK		20mm	CLM-8-TNS	CL-54-STC	CL-20-BS	
CLM-9-CK		13/16	CLM-9-TNS	CL-56-STC	CL-30-BS	

HEAVY BLOCKS (INCH)

PART NO.	STUD SIZE	TABLE SLOT SIZE	T-NUT & STUD SET (1)	STEP CLAMPS (2) EACH	STEP BLOCK PAIRS (2) EACH	HOLDER (1)
CL-10-CK	1/2-13	7/16	CL-4-TNS	CL-42-STC CL-44-STC CL-46-STC	CL-40-BS CL-50-BS CL-60-BS	CL-4-CKH
CL-11-CK		12mm	CL-5-TNS			
CL-12-CK		1/2	CL-6-TNS			
CL-26-CK		9/16 or 14mm	CL-18-TNS			
CL-13-CK	5/8-11	5/8 or 16mm	CL-7-TNS	CL-52-STC CL-54-STC CL-56-STC	CL-40-BS CL-50-BS CL-60-BS	CL-5-CKH
CL-14-CK		9/16 or 14mm	CL-8-TNS			
CL-22-CK		5/8 or 16mm	CL-15-TNS			
CL-15-CK		11/16 or 18mm	CL-9-TNS			
CL-16-CK	3/4-10	3/4	CL-10-TNS	CL-64-STC CL-66-STC CL-68-STC	CL-40-BS CL-50-BS CL-60-BS	CL-6-CKH
CL-23-CK		11/16 or 18mm	CL-16-TNS			
CL-17-CK		7/8	CL-11-TNS			
CL-18-CK		20mm	CL-12-TNS			
CL-19-CK		13/16	CL-13-TNS			

HEAVY BLOCKS (METRIC)

CLM-10-CK	M12	9/16 or 14mm	CLM-4-TNS	CL-42-STC	CL-40-BS	CL-4-CKH
CLM-11-CK	M12	5/8 or 16mm	CLM-5-TNS	CL-44-STC	CL-50-BS	
CLM-12-CK		11/16 or 18mm	CLM-6-TNS	CL-46-STC	CL-60-BS	
CLM-13-CK	M16	11/16 or 18mm	CLM-7-TNS	CL-52-STC	CL-40-BS	CL-5-CKH
CLM-14-CK		20mm	CLM-8-TNS	CL-54-STC	CL-50-BS	
CLM-15-CK		13/16	CLM-9-TNS	CL-56-STC	CL-60-BS	
CLM-17-CK	M20	22mm	CLM-11-TNS	CL-64-STC CL-66-STC CL-68-STC	CL-40-BS CL-50-BS CL-60-BS	CL-6-CKH

DELUXE CLAMPING KITS

SEE CATALOG PAGE OF EACH COMPONENT FOR MATERIAL SPECIFICATIONS
 HOLDER: STEEL, ENAMEL PAINT

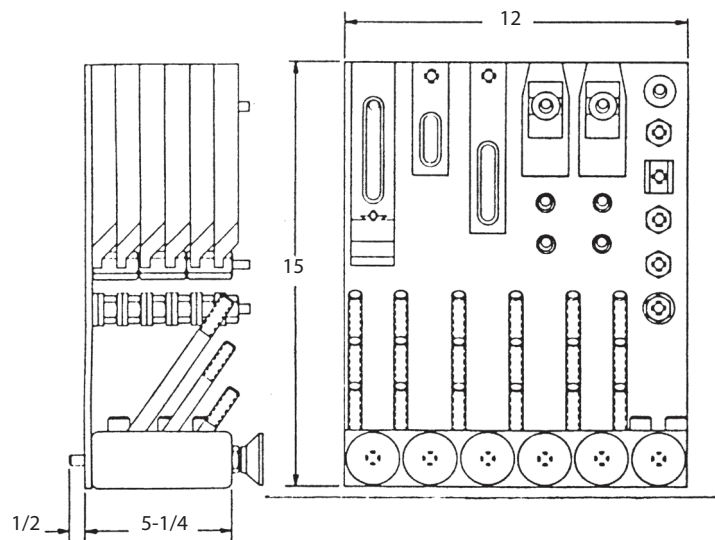
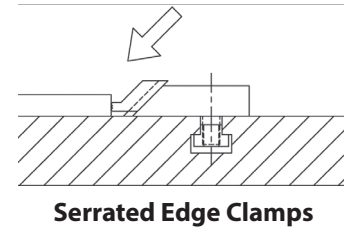
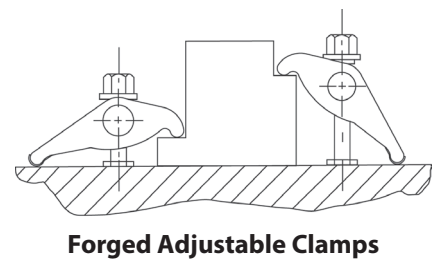
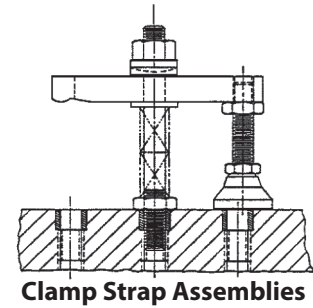
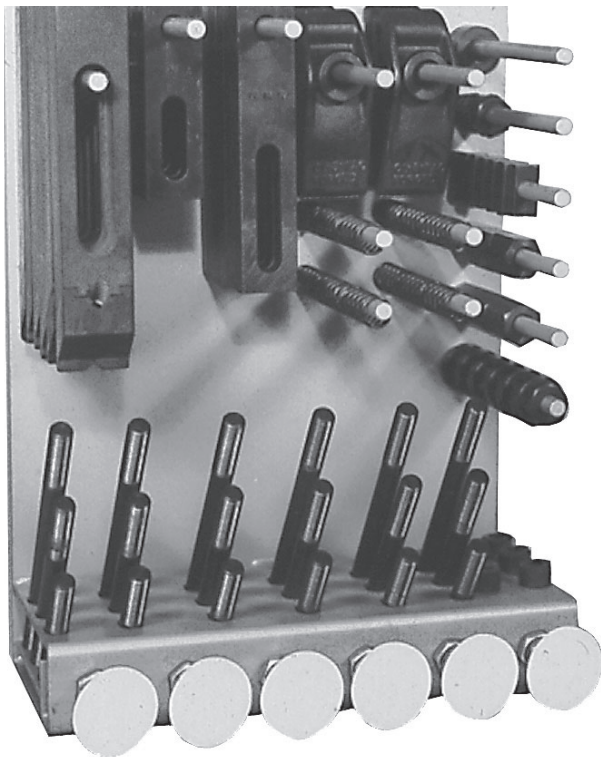

New, improved Clamping Kit with three different types of clamps. Safer and less cumbersome than sets using Step Blocks and Clamps. This 94-piece set includes:

- (12) Tapped-Heel Clamp Straps, short and long
- (4) Forged Adjustable Clamps
- (6) Serrated Edge Clamps
- (6) Stud Leveling Feet
- (6) T Nuts
- (6) Short Clamping Studs
- (6) Medium Clamping Studs
- (6) Long Clamping Studs
- (6) Spherical Nuts & Washers
- (6) Coupling Nuts
- (6) Jam Nuts
- (6) Flat Washers
- (12) Clamp Springs
- (6) Socket-Head Cap Screws
- (1) Sturdy Steel Rack

Available to fit table-slot sizes from 7/16" to 13/16" (12mm to 20mm in metric), in thread sizes from 3/8"-16 to 5/8"-11 (M10 to M16 in metric).

The Stud Leveling Feet in these kits serve as the rear supports for Tapped-Heel Clamp Straps. These leveling feet are optionally available with Delrin® pads to avoid marring the table when less clamping force is required, such as when used on coordinate measuring machines.

DELUXE CLAMPING KITS

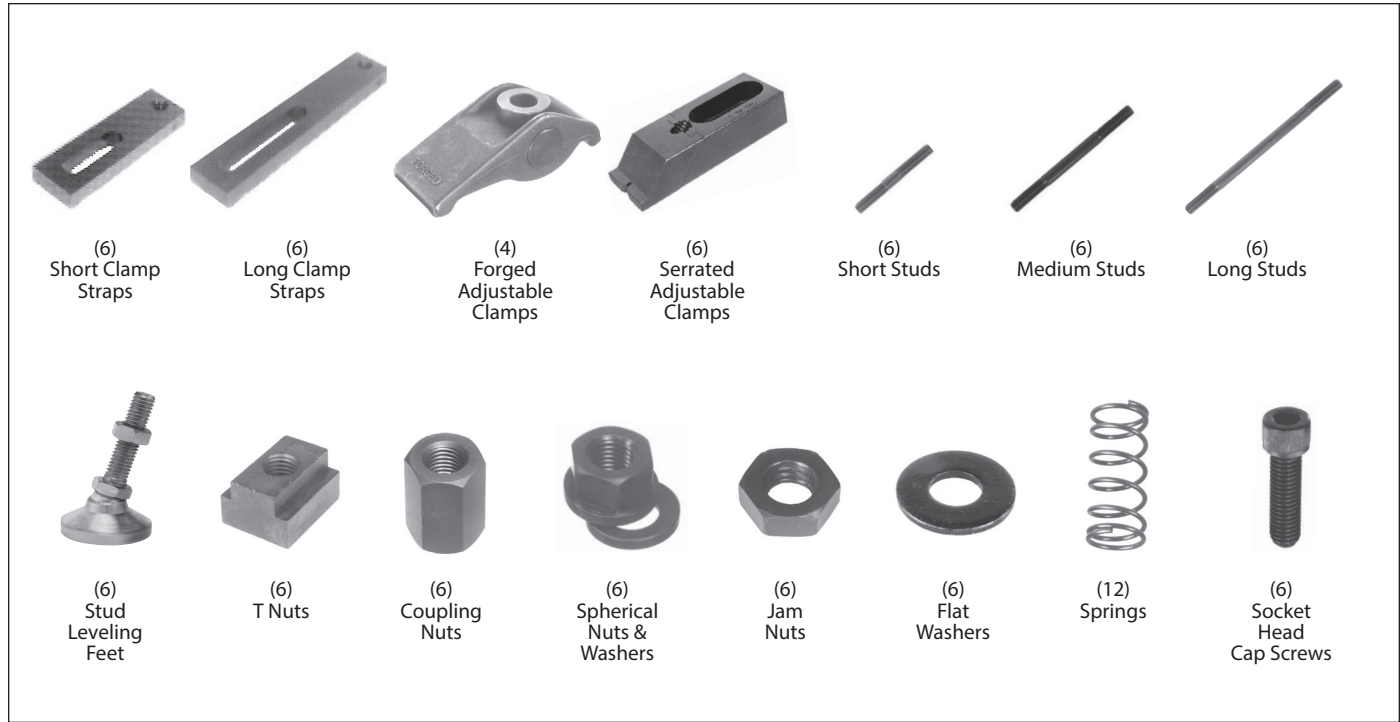

7

INCH

PART NO. STEEL PADS	PART NO. DELRIN® PADS	TABLE SLOT SIZE	STUD SIZE	CLAMP STRAPS (6 EACH)	FORGED ADJ. CLPS. (4)	SERR. ADJ. CLPS. (4)	STUDS (6 EACH)	LEVELING FEET (6)	T NUTS (6)	NUTS & WASHERS (6 EACH)	SPRINGS (12)	SOCKET-HEAD CAP SCREWS (6)
CL-1-DCK	CL-1-DCKN	7/16	3/8-16	CL-63-CS CL-67-CS	CL-6-FAC	CL-30-SAC	CL-3/8-16x3.00-STUD CL-3/8-16x5.00-STUD CL-3/8-16x7.00-STUD	CL-6-SLF-BO or CL-6-SLFN	CL-00-TN	CL-1-CN CL-2-SNW CL-6-JN CL-1-FW	CL-9-SPG	CL-3/8-16x1.25-SHCS
CL-20-DCK	CL-20-DCKN	12mm							CL-12-TN			
CL-2-DCK	CL-2-DCKN	1/2							CL-0-TN			
CL-3-DCK	CL-3-DCKN	9/16 or 14mm							CL-1-TN			
CL-24-DCK	CL-24-DCKN	5/8 or 16mm	1/2-13	CL-71-CS CL-75-CS	CL-8-FAC	CL-60-SAC	CL-1/2-13x4.00-STUD CL-1/2-13x6.00-STUD CL-1/2-13x8.00-STUD	CL-8-SLF-BO or CL-8-SLFN	CL-16-TN	CL-2-CN CL-3-SNW CL-8-JN CL-2-FW	CL-9-SPG	CL-1/2-13x1.50-SHCS
CL-4-DCK	CL-4-DCKN	9/16 or 14mm							CL-9-TN			
CL-5-DCK	CL-5-DCKN	5/8 or 16mm							CL-2-TN			
CL-6-DCK	CL-6-DCKN	11/16 or 18mm							CL-3-TN			
CL-7-DCK	CL-7-DCKN	3/4	5/8-11	CL-81-CS CL-85-CS	CL-10-FAC	CL-90-SAC	CL-5/8-11x4.00-STUD CL-5/8-11x6.00-STUD CL-5/8-11x8.00-STUD	CL-10-SLF-BO or CL-10-SLFN	CL-17-TN	CL-10-TN CL-4-SNW CL-10-JN CL-3-FW	CL-9-SPG	CL-5/8-11x1.50-SHCS
CL-27-DCK	CL-27-DCKN	11/16 or 18mm							CL-10-TN			
CL-8-DCK	CL-8-DCKN	3/4							CL-4-TN			
CL-21-DCK	CL-21-DCKN	20mm							CL-14-TN			
CL-9-DCK	CL-9-DCKN	13/16							CL-5-TN			

METRIC

CLM-1-DCK	CLM-1-DCKN	12mm	M10	CLM-63-CS CLM-67-CS	CL-6-FAC	CL-30-SAC	CLM-10x80-STUD CLM-10x125-STUD CLM-10x175-STUD	CLM-10-SLF-BO or CLM-10-SLFN	CLM-00-TN	CLM-10-CN CLM-10-SNW CLM-10-JN	CL-7-SPG	CLM-10x30-SHCS
CLM-2-DCK	CLM-2-DCKN	1/2							CLM-0-TN			
CLM-3-DCK	CLM-3-DCKN	9/16 or 14mm							CLM-1-TN			
CLM-4-DCK	CLM-4-DCKN	9/16 or 14mm	M12	CLM-71-CS CLM-75-CS	CL-8-FAC	CL-60-SAC	CLM-12x95-STUD CLM-12x150-STUD CLM-12x200-STUD	CLM-12-SLF-BO or CLM-12-SLFN	CLM-9-TN	CLM-12-CN CLM-12-SNW CLM-12-JN	CL-9-SPG	CLM-12x40-SHCS
CLM-5-DCK	CLM-5-DCKN	5/8 or 16mm							CLM-2-TN			
CLM-6-DCK	CLM-6-DCKN	11/16 or 18mm							CLM-3-TN			
CLM-7-DCK	CLM-7-DCKN	11/16 or 18mm	M16	CLM-81-CS CLM-85-CS	CL-10-FAC	CL-90-SAC	CLM-16x110-STUD CLM-16x150-STUD CLM-16x200-STUD	CLM-16-SLF-BO or CLM-16-SLFN	CLM-10-TN	CLM-16-CN CLM-16-SNW CLM-16-JN	CL-11-SPG	CLM-16x40-SHCS
CLM-8-DCK	CLM-8-DCKN	20mm							CLM-4-TN			
CLM-9-DCK	CLM-9-DCKN	13/16							CLM-5-TN			

SWING C CLAMPS

FRAME & MOUNTING PAD: MILD STEEL, ZINC PLATED CLEAR CHROMATE

KNOB: 319 ALUMINUM ALLOY

SCREW: 1215 STEEL, NICKEL PLATED

FOOT: 1215 STEEL, ZINC PLATED YELLOW CHROMATE

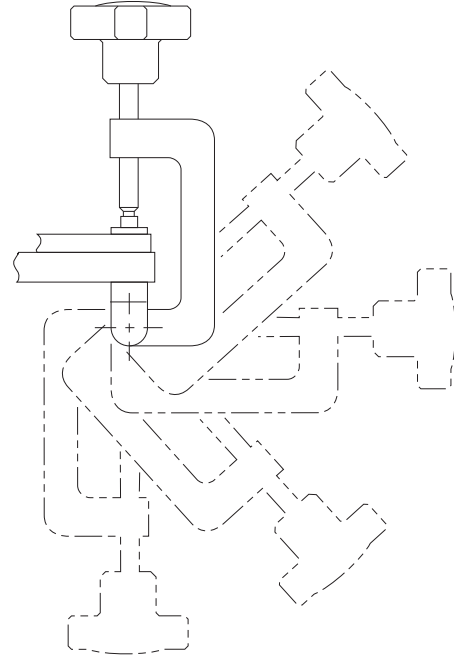

7

These unique C Clamps have a hinged pad for fastening permanently to a fixture, allowing them to swing clear for workpiece loading. The hinged mounting pad bolts to the fixture with two Socket-Head Cap Screws. Four-Prong Knob provides a firm grip for applications requiring quick tightening and high torque. Clamping screw is cast securely in the knob and has a removable swivel foot. Available in four sizes.

Swing C Clamps use our patented left-hand-thread swivel-foot system. The ball end of the body screws into the foot for easy installation and removal. Once the ball threads pass beyond the foot threads, the foot can rotate and pivot freely (20° total angle). Foot threads are left-hand to positively prevent accidental black out during use. For other foot types, including Delrin® feet, see Feet for Swivel Screws (order separately).

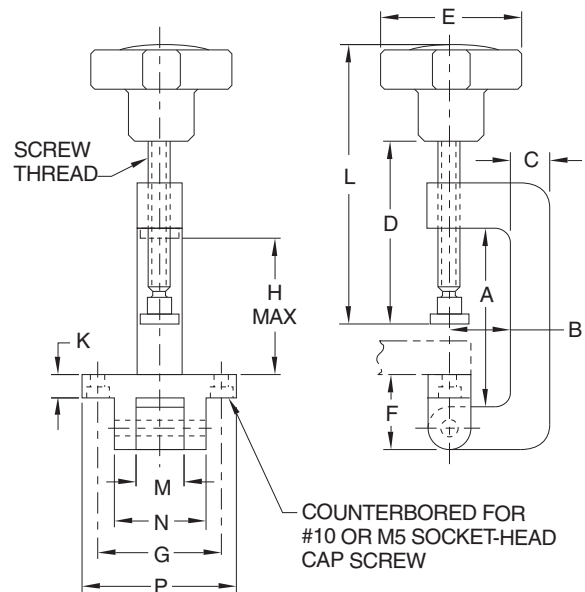

PART NO.	SCREW THREAD	A	B	C	D	E	F	G	H	K	L	M	N	P
CL-525-SCC	5/16-18	2-1/2	3/4	1/2	2-1/4	1-3/4	7/8	1-1/2	1-31/32	5/16	3-1/4	1/2	1	2
CL-625-SCC	3/8-16	2-1/2	1	5/8	2-13/16	2-1/8	1	1-3/4	1-15/16		4-1/16	5/8	1-1/4	2-1/4
CL-635-SCC		3-1/2			3-9/16				2-15/16		4-13/16			

FORGED ADJUSTABLE DRILL-PRESS CLAMPS

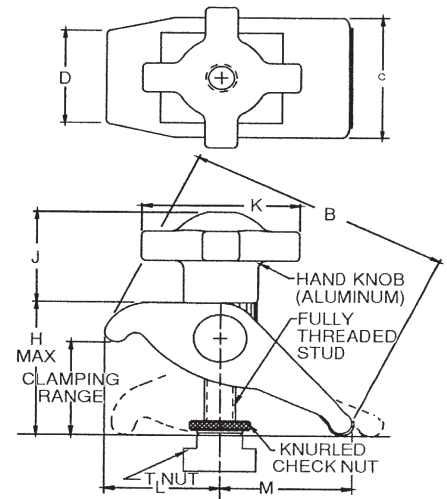
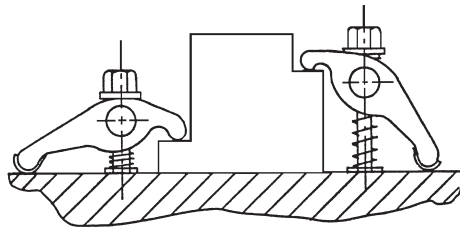
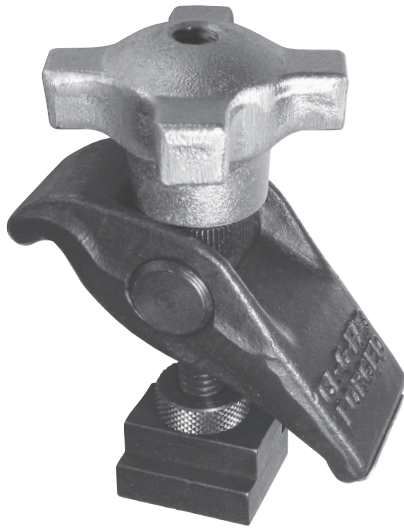

Handy hold-down clamp assembly that includes a Forged Adjustable Clamp, ideal for clamping on T-slotted drill presses and tapped drill-jig plates. This rugged forged steel pivot clamp provides instant height adjustment without blocks or shims. Removable brass heel protects machine table. Available with stud sizes from 5/16-18 to 1/2-13 (M8 to M12 in metric), fitting T-slots from 3/8 to 3/4 (10mm to 18mm in metric). **INFO+**: For additional sizes of Forged Adjustable Clamps, see page 277.

GENERAL DIMENSIONS

STUD SIZE	CLAMPING RANGE	B	C	D	H	J	K	L		M	
								MIN	MAX	MIN	MAX
5/16-18 or M8 3/8-16 or M10	0 to 1-3/4	3-1/4	1-1/4	7/8	2-1/8	1-3/8	2-1/8	1-1/16	1-1/4	1-3/4	2
1/2-13 or M12	0 to 2-1/16	4	1-5/8	1-1/8	2-5/8	1-5/8	2-1/2	1-3/8	1-9/16	2-1/8	2-7/16

ASSEMBLY COMPONENTS (INCH)

PART NO.	STUD SIZE	TABLE-SLOT SIZE	T NUT	FORGED ADJUSTABLE CLAMP	FULLY THREADED STUD	KNURLED CHECK NUT	HAND KNOB
CL-5-FACA-HKA	5/16-18	TAPPED	NONE	CL-6-FAC	CL-5/16-18x3.00-FTS	CL-51618-TSJN	CL-2-HK-4A
CL-5-FACA-HKA-19		3/8 or 10mm	CL-19-TN				
CL-5-FACA-HKA-20		7/16	CL-20-TN				
CL-5-FACA-HKA-21		1/2	CL-21-TN				
CL-6-FACA-HKA	3/8-16	TAPPED	NONE	CL-6-FAC	CL-3/8-16x3.00-FTS	CL-3816-TSJN	CL-3-HK-4A
CL-6-FACA-HKA-00		7/16	CL-00-TN				
CL-6-FACA-HKA-12		12mm	CL-12-TN				
CL-6-FACA-HKA-0		1/2	CL-0-TN				
CL-6-FACA-HKA-1		9/16 or 14mm	CL-1-TN				
CL-6-FACA-HKA-16		5/8 or 16mm	CL-16-TN				
CL-8-FACA-HKA	1/2-13	TAPPED	NONE	CL-8-FAC	CL-1/2-13x4.00-FTS	CL-1213-TSJN	CL-9-HK-9A
CL-8-FACA-HKA-9		9/16 or 14mm	CL-9-TN				
CL-8-FACA-HKA-2		5/8 or 16mm	CL-2-TN				
CL-8-FACA-HKA-3		11/16 or 18mm	CL-3-TN				
CL-8-FACA-HKA-17		3/4	CL-17-TN				

ASSEMBLY COMPONENTS (METRIC)

CLM-5-FACA-HKA	M8	TAPPED	NONE	CL-6-FAC	CLM-8x80-FTS	CLM-8-TSJN	CLM-2-HK-4A
CLM-5-FACA-HKA-19		3/8 or 10mm	CLM-19-TN				
CLM-6-FACA-HKA		TAPPED	NONE				
CLM-6-FACA-HKA-00	M10	12mm	CLM-00-TN	CL-6-FAC	CLM-10x80-FTS	CLM-10-TSJN	CLM-3-HK-4A
CLM-6-FACA-HKA-0		1/2	CLM-0-TN				
CLM-6-FACA-HKA-1		9/16 or 14mm	CLM-1-TN				
CLM-8-FACA-HKA	M12	TAPPED	NONE	CL-8-FAC	CLM-12x110-FTS	CLM-12-TSJN	CLM-9-HK-9A
CLM-8-FACA-HKA-9		9/16 or 14mm	CLM-9-TN				
CLM-8-FACA-HKA-2		5/8 or 16mm	CLM-2-TN				
CLM-8-FACA-HKA-3		11/16 or 18mm	CLM-3-TN				

DRILL-PRESS TOGGLE CLAMPS

DRILL-PRESS ADAPTOR: 6061 ALUMINUM

OTHER COMPONENTS: SEE CATALOG PAGE FOR EACH SPECIFIC ITEM

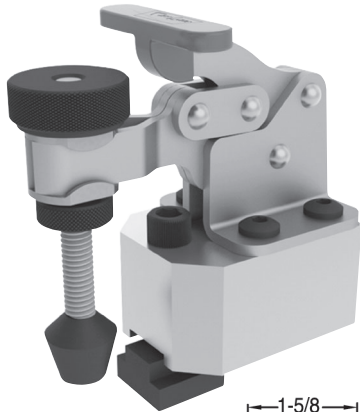

These hold-down Toggle Clamps are ideal for clamping on drill presses, with an adaptor base for slotted tables and a quick adjusting spindle. Choose either a compact, easy-opening vertical T handle, or a low-profile horizontal handle. Open arm provides adjustable spindle location. Supplied with two quick-adjusting Flat-Cushion Spindles, one short and one long. Choose T Nut size to fit table slots from 3/8 to 5/8" (10 to 16mm in metric).

Vertical T Handle

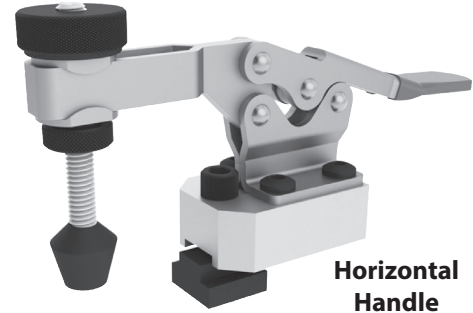

Horizontal Handle

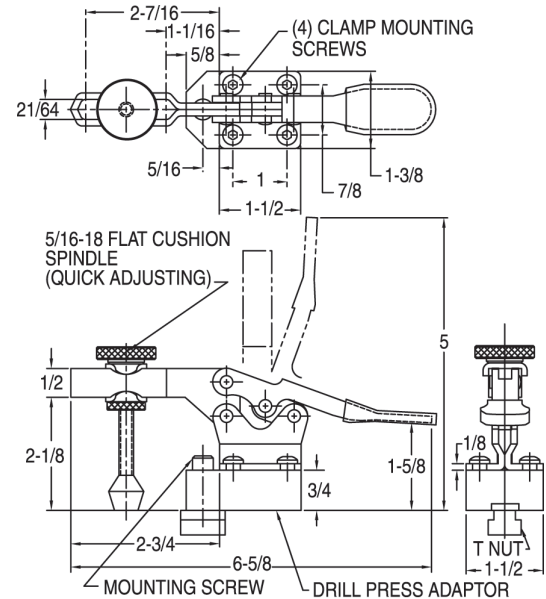
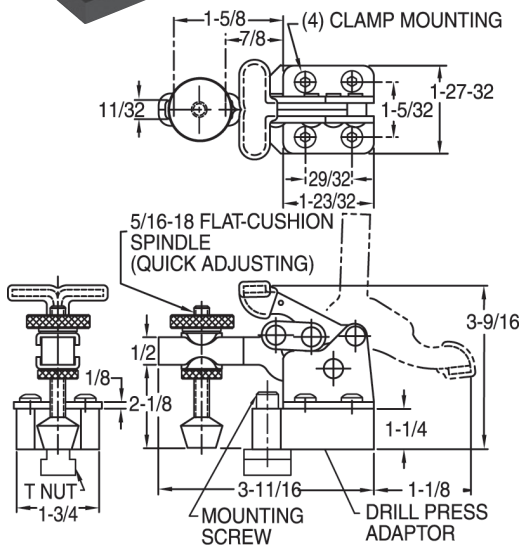

VERTICAL T HANDLE (INCH)

PART NO.	MOUNTING SCREW SIZE	TABLE-SLOT SIZE	T NUT	DRILL-PRESS ADAPTOR	MOUNTING SCREW	CLAMP MOUNTING SCREW(4)	QUICK-ADJUSTING SPINDLE	HOLDING CAPACITY (LBS)
CL-300-VTCD-5	5/16-18	TAPPED	NONE	CL-300-VTCA-6	CL-5/16-18x1.75-SHCS	CL-1/4-20x.50-BHCS	CL-516212-FCQA	350
CL-300-VTCD-5-19		3/8 or 10mm	CL-19-TN		CL-5/16-18x1.50-SHCS			
CL-300-VTCD-5-20		7/16	CL-20-TN		CL-3/8-16x1.75-SHCS			
CL-300-VTCD-5-21		1/2	CL-21-TN					
CL-300-VTCD-6	3/8-16	TAPPED	NONE		CL-3/8-16x1.50-SHCS			
CL-300-VTCD-6-00		7/16	CL-00-TN		CL-3/8-16x1.50-SHCS			
CL-300-VTCD-6-12		12mm	CL-12-TN					
CL-300-VTCD-6-0		1/2	CL-0-TN					
CL-300-VTCD-6-1		9/16 or 14mm	CL-1-TN					
CL-300-VTCD-6-16		5/8 or 16mm	CL-16-TN					

HORIZONTAL HANDLE (INCH)

CL-450-HTCD-5	5/16-18	TAPPED	NONE	CL-450-HTCA-6	CL-5/16-18x1.75-SHCS	CL-1/4-20x.50-BHCS	CL-516212-FCQA	500
CL-450-HTCD-5-19		3/8 or 10mm	CL-19-TN		CL-5/16-18x1.50-SHCS			
CL-450-HTCD-5-20		7/16	CL-20-TN		CL-3/8-16x1.75-SHCS			
CL-450-HTCD-5-21		1/2	CL-21-TN					
CL-450-HTCD-6	3/8-16	TAPPED	NONE		CL-3/8-16x1.50-SHCS			
CL-450-HTCD-6-00		7/16	CL-00-TN		CL-3/8-16x1.50-SHCS			
CL-450-HTCD-6-12		12mm	CL-12-TN					
CL-450-HTCD-6-0		1/2	CL-0-TN					
CL-450-HTCD-6-1		9/16 or 14mm	CL-1-TN					
CL-450-HTCD-6-16		5/8 or 16mm	CL-16-TN					

CARR LANE SIMPLEX HAMMERS

SEE COMPONENT PAGES FOR MATERIAL SPECIFICATIONS



Wooden Handle



Fiberglass Handle

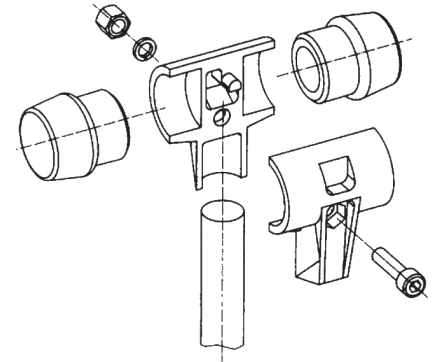

Design your own custom hammers. These soft-face mallets can be customized for specific applications by selecting the proper hammer inserts. Choose the same type of insert for both sides, or build a multi-purpose hammer with a different type of insert for each face. The Simplex system uses a patented hammer housing with 3-point clamping that ensures a safe hammer assembly.

Available in four sizes, with a choice of eight different insert materials:

- Type A Blue Thermoplastic (Soft)
- Type B Gray Thermoplastic (Medium Soft)
- Type C Black Rubber (Medium Soft)
- Type D White Superplastic (Medium Hard)
- Type E Red Plastic (Hard)
- Type F White Nylon (Hard)
- Type G Soft Metal (Hard)
- Type H Copper (Hard) Fiberglass Handle Only

To order a 30mm hammer with a wooden handle, one black rubber insert (C) and one white nylon insert (F) specify:

CL-30-SPH-W-CF

Observe all appropriate safety precautions. Always wear safety goggles when using a hammer or any striking tool. Bystanders must also wear safety goggles. Never strike the hammer with or against another striking tool, hardened nail, or any other hard object that could cause damage. Chipping could occur, resulting in possible eye or other injury. Discard any chipped or damaged hammer. If assembling the hammer yourself, ensure that all parts are properly fitted into the handle housing and that the screw is tightened to the specified torque. Check hammer before each use. Using a hammer with loose or improperly fitted parts could result in serious injury. Use only genuine Simplex replacement components.

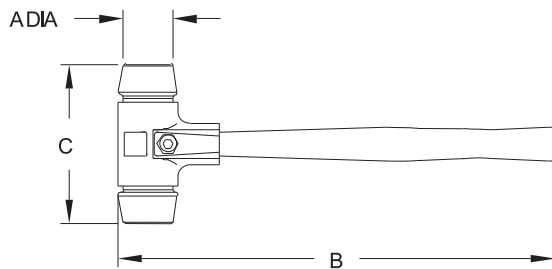

SIMPLEX HAMMER ASSEMBLY — WOODEN HANDLE

PART NO.	A DIA	B	C	WEIGHT (LBS)
CL-30-SPH-W-xx	30mm (1.18)	11.81	3.54	0.7-0.9
CL-40-SPH-W-xx	40mm (1.57)	12.99	4.33	1.3-1.6
CL-50-SPH-W-xx	50mm (1.96)	13.78	5.32	2.4-3.0
CL-60-SPH-W-xx	60mm (2.36)	15.95	5.71	3.1-4.3

SIMPLEX HAMMER ASSEMBLY — FIBERGLASS HANDLE

CL-30-SPH-F-xx	30mm (1.18)	11.81	3.54	0.9-1.5
CL-40-SPH-F-xx	40mm (1.57)	12.99	4.33	1.8-3.1
CL-50-SPH-F-xx	50mm (1.96)	13.78	5.32	3.3-4.0
CL-60-SPH-F-xx	60mm (2.36)	15.95	5.71	3.5-5.5

CARR LANE SIMPLEX HAMMERS



Type A Inserts
Blue Thermoplastic
(Soft)

Blue thermoplastic inserts are soft and non-smudging. Applications include assembly operations, dent removal, woodworking, furniture assembly, window and door construction, joiner's work, and floor tiling. Hardness 60-70 Shore A.

PART NO.	HAMMER SIZE (FACE DIA)
CL-30-SPH-A	30mm (1.18)
CL-40-SPH-A	40mm (1.57)
CL-50-SPH-A	50mm (1.96)
CL-60-SPH-A	60mm (2.36)



Type B Inserts
Grey Thermoplastic
(Medium Soft)

Gray thermoplastic inserts are medium soft and non-smudging. Applications include assembly operations, car-body work, woodworking, furniture assembly, window and door construction, joiner's work, floor tiling, paving, and interior construction. Hardness 85-95 Shore A.

PART NO.	HAMMER SIZE (FACE DIA)
CL-30-SPH-B	30mm (1.18)
CL-40-SPH-B	40mm (1.57)
CL-50-SPH-B	50mm (1.96)
CL-60-SPH-B	60mm (2.36)



Type C Inserts
Black Rubber
(Medium Soft)

Black Rubber inserts are medium soft. Applications include assembly operations, dent removal, prefabricated housing construction, carpenter's work, paving, masonry work, concrete-form setup, scaffold construction, gardening, landscaping, and interior construction. Hardness 90-100 Shore A.

PART NO.	HAMMER SIZE (FACE DIA)
CL-30-SPH-C	30mm (1.18)
CL-40-SPH-C	40mm (1.57)
CL-50-SPH-C	50mm (1.96)
CL-60-SPH-C	60mm (2.36)



Type D Inserts
White Superplastic
(Medium Hard)

White superplastic inserts (UHMW polyethylene) are medium hard, durable, impact resistant, acid and lye resistant, grease and oil resistant, and ideal for striking sharp edges. Applications include assembly operations, automotive assembly and repair work, repair and maintenance work, car body work, sheet metal working, dent removal, assembly of sharp-edged workpieces, paving, masonry work, scaffold construction, gardening, and landscaping. Hardness 60-70 Shore D.

PART NO.	HAMMER SIZE (FACE DIA)
CL-30-SPH-D	30mm (1.18)
CL-40-SPH-D	40mm (1.57)
CL-50-SPH-D	50mm (1.96)
CL-60-SPH-D	60mm (2.36)



Type E Inserts
Red Plastic
(Hard)

Red plastic inserts (cellulose acetate) are hard, semi-transparent, and grease and oil resistant. Applications include automotive assembly and repair work, sheet metal working, dent removal, concrete-form setup, and scaffold construction. Hardness 65-75 Shore D.

PART NO.	HAMMER SIZE (FACE DIA)
CL-30-SPH-E	30mm (1.18)
CL-40-SPH-E	40mm (1.57)
CL-50-SPH-E	50mm (1.96)
CL-60-SPH-E	60mm (2.36)



Type F Inserts
White Nylon
(Hard)

White nylon inserts are hard, grease and oil resistant, highly elastic, and have superior strike effectiveness. Applications include assembly operations, metalworking, tooling, automotive assembly and repair work, joining of workpieces, sheet metal working, dent removal, mold construction, assembly of sharp-edged workpieces, and scaffold construction. Hardness 68-78 Shore D.

PART NO.	HAMMER SIZE (FACE DIA)
CL-30-SPH-F	30mm (1.18)
CL-40-SPH-F	40mm (1.57)
CL-50-SPH-F	50mm (1.96)
CL-60-SPH-F	60mm (2.36)



Type G Inserts
Soft Metal
(Hard)

Soft metal inserts are made of an aluminum-copper alloy which is hard and resistant to heat. Excellent alternative to old-fashioned lead hammers, to eliminate the risk of lead contamination. Applications include metalworking, tooling, automotive assembly and repair work, straightening work, car body work, and mold construction.

PART NO.	HAMMER SIZE (FACE DIA)
CL-30-SPH-G	30mm (1.18)
CL-40-SPH-G	40mm (1.57)
CL-50-SPH-G	50mm (1.96)
CL-60-SPH-G	60mm (2.36)



Type H Inserts
Copper
(Hard)

Copper inserts are hard and provide maximum impact. Plastic socket provides for secure mounting of the copper insert in the hammer. Applications include machine construction, automotive assembly and repair work, repair and maintenance work, and vehicle service stations.

PART NO.	HAMMER SIZE (FACE DIA)
CL-30-SPH-H	30mm (1.18)
CL-40-SPH-H	40mm (1.57)

CARR LANE SIMPLEX HAMMERS

HOUSINGS: CAST IRON, FURNISHED WITH SOCKET-HEAD CAP SCREW, SPRING WASHER, AND NUT
HANDLES: EUROPEAN BLACK LOCUST WOOD, OR FIBERGLASS WITH ERGONOMIC RUBBER GRIP

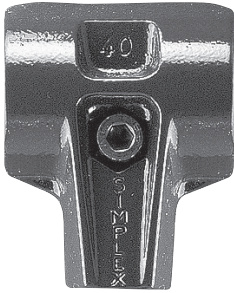

Rugged cast iron housing (red), furnished with a high-strength Socket-Head Cap Screw, spring washer, and nut. Premium quality hardwood handle. Use wooden handles only with red housings.



HOUSING & HANDLE — WOODEN HANDLE

HOUSING PART NO.	HANDLE PART NO.	HAMMER SIZE (FACE DIA)	TIGHTENING TORQUE (FT-LBS)	
			PLASTIC INSERTS	METAL INSERTS
CL-30-SPH-HWH	CL-30-SPH-WH	30mm (1.18)	11	15
CL-40-SPH-HWH	CL-40-SPH-WH	40mm (1.57)	18	30
CL-50-SPH-HWH	CL-50-SPH-WH	50mm (1.96)	22	37
CL-60-SPH-HWH	CL-60-SPH-WH	60mm (2.36)	30	48



Heavy-duty cast iron housing (black), reinforced for use with a fiberglass handle, furnished with a high-strength Socket-Head Cap Screw, spring washer, and nut. High-strength fiberglass handle with an ergonomic rubber grip. Use fiberglass handles only with black housings.



7

HOUSING & HANDLE — FIBERGLASS HANDLE

HOUSING PART NO.	HANDLE PART NO.	HAMMER SIZE (FACE DIA)	TIGHTENING TORQUE (FT-LBS)	
			PLASTIC INSERTS	METAL INSERTS
CL-30-SPH-HFH	CL-30-SPH-FH	30mm (1.18)	18	30
CL-40-SPH-HFH	CL-40-SPH-FH	40mm (1.57)	22	44
CL-50-SPH-HFH	CL-50-SPH-FH	50mm (1.96)	30	52
CL-60-SPH-HFH	CL-60-SPH-FH	60mm (2.36)	44	59

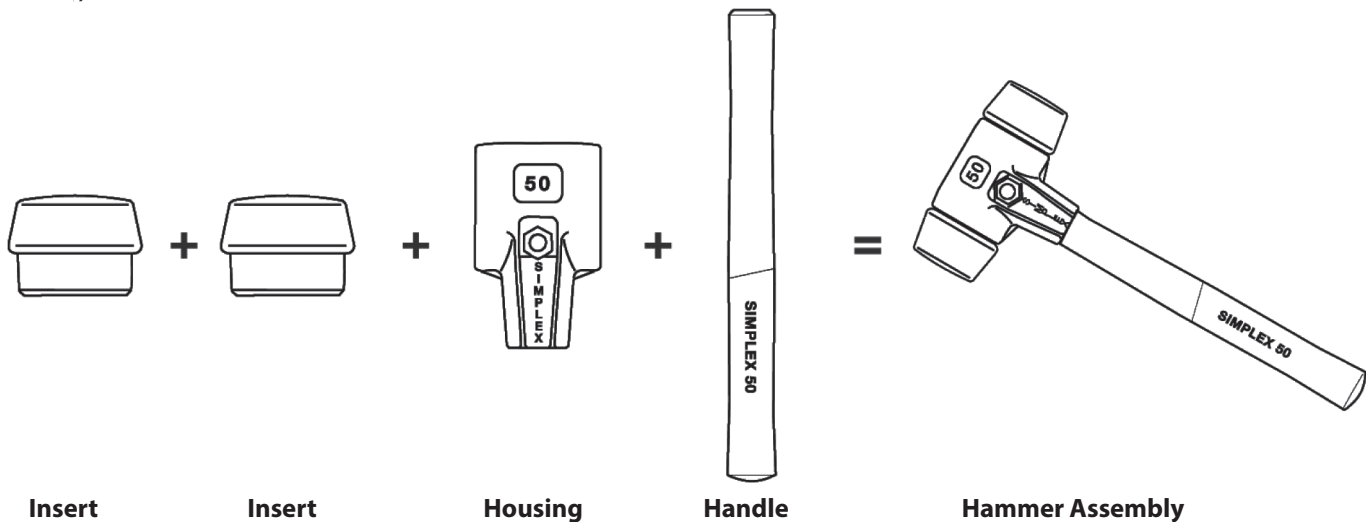

NO-REBOUND HAMMERS

HOUSINGS: STEEL ASSEMBLY CONTAINING STEEL PELLETS. HANDLE: HICKORY WOOD.
 INSERTS: NYLON, NATURAL WHITE COLOR, HARDNESS 68-78 SHORE D



**Supercraft
Hammers
(Wooden Handle)**

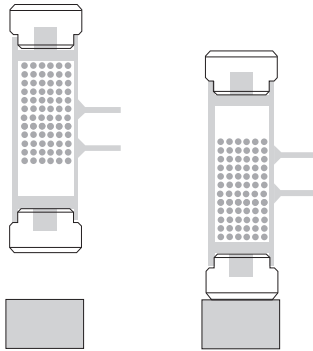

No-Rebound Hammers are filled with special steel pellets that transfer momentum to the impact point.

No-Rebound Hammers deliver full impact, about 50% greater than a standard hammer. The housing is filled with special steel pellets that transfer momentum to the impact point. Ideal for assembling machine parts without damage. Speeds up work while reducing fatigue. Allows better hammer control by absorbing the bounce. Hickory-wood handle. Available in five standard sizes, plus two sledgehammer sizes.

Supercraft No-Rebound Hammers have replaceable nylon inserts. These nylon inserts are hard, grease and oil resistant, highly elastic, and have superior strike effectiveness. Applications include assembly operations, metalworking, tooling, positioning of workpieces, automotive assembly and repair work, joining of workpieces, sheet metal working, dent removal, mold construction, assembly of sharp-edged workpieces, and scaffold construction.

Observe all appropriate safety precautions. Never allow the hammer's striking faces to wear down to the point where the hammer housing makes contact with the work surface, as irreparable damage could result. Always wear safety goggles when using a hammer or any striking tool. Bystanders must also wear safety goggles. Never strike the hammer with or against another striking tool, hardened nail, or any other hard object that could cause damage. Chipping could occur, resulting in possible eye or other injury. Discard any chipped or damaged hammer.

SUPERCRAFT HAMMERS — WOODEN HANDLE

PART NO.	FACE DIA	WEIGHT (LBS)	OVERALL LENGTH	HEAD LENGTH	REPLACEMENT INSERT (2 REQUIRED)
CL-3366-020-NRH	20mm (.78)	0.5	11.77	4.12	CL-3508-020-NRHI
CL-3366-030-NRH	30mm (1.18)	0.7	12.95	4.32	CL-3508-030-NRHI
CL-3366-040-NRH	40mm (1.57)	1.6	14.13	4.51	CL-3508-040-NRHI
CL-3366-050-NRH	50mm (1.96)	2.2	14.52	4.71	CL-3508-050-NRHI
CL-3366-060-NRH	60mm (2.36)	3.8	14.52	5.69	CL-3508-060-NRHI



**Supercraft
Sledgehammers
(Wooden Handle)**

SUPERCRAFT SLEDGEHAMMERS — WOODEN HANDLE

PART NO.	FACE DIA	WEIGHT (LBS)	OVERALL LENGTH	HEAD LENGTH	REPLACEMENT INSERT (2 REQUIRED)
CL-3366-081-NRH	80mm (3.14)	9	34.5	7.85	CL-3508-080-NRHI
CL-3366-107-NRH	100mm (3.93)	15	39.2	8.24	CL-3508-100-NRHI

NO-REBOUND HAMMERS

HOUSING & HANDLE: STEEL ASSEMBLY CONTAINING STEEL PELLETS
 SUPERCRAFT INSERTS: NYLON, NATURAL WHITE COLOR, HARDNESS 68-78 SHORE D
 SECURAL INSERTS: POLYURETHANE, YELLOW



**Supercraft Hammers
(Steel Handle)**



**HI-VIS
Supercraft Hammers
(Steel Handle)**



**Secural
Narrow Hammers
(Steel Handle)**

Also available in a high-visibility version!

No-Rebound Hammers deliver full impact, about 50% greater than a standard hammer. The housing is filled with special steel pellets that transfer momentum to the impact point. Ideal for assembling machine parts without damage. Speeds up work while reducing fatigue. Allows better hammer control by absorbing the bounce. Steel handle with ergonomic rubber grip.

Supercraft No-Rebound Hammers are available in four sizes, now optionally available with a high-visibility yellow fluorescent finish, ideal for locating your hammer in dim lighting conditions. Supercraft Hammers have replaceable nylon inserts. These nylon inserts are hard, grease and oil resistant, highly elastic, and have superior strike effectiveness.

Secural Narrow No-Rebound Hammers have a narrow, rectangular head that allows hammering in tight spots, and also makes storage easier in toolbox drawers. Available in one size, with a 30mm x 40mm face. Secural Narrow Hammers have replaceable polyurethane inserts. These inserts are medium soft.

Observe all appropriate safety precautions. Never allow the hammer's striking faces to wear down to the point where the hammer housing makes contact with the work surface, as irreparable damage could result. Always wear safety goggles when using a hammer or any striking tool. Bystanders must also wear safety goggles. Never strike the hammer with or against another striking tool, hardened nail, or any other hard object that could cause damage. Chipping could occur, resulting in possible eye or other injury. Discard any chipped or damaged hammer.

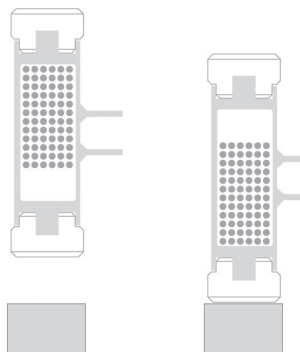

No-Rebound Hammers are filled with special steel pellets that transfer momentum to the impact point.

SUPERCRAFT HAMMERS — STEEL HANDLE

PART NO.	FACE DIA	WEIGHT (LBS)	OVERALL LENGTH	HEAD LENGTH	REPLACEMENT INSERT (2 REQUIRED)
CL-3377-030-NRH	30mm (1.18)	1.3	11.38	4.32	CL-3508-030-NRHI
CL-3377-040-NRH	40mm (1.57)	1.9	11.77	4.51	CL-3508-040-NRHI
CL-3377-050-NRH	50mm (1.96)	2.6	12.17	4.71	CL-3508-050-NRHI
CL-3377-060-NRH	60mm (2.36)	3.9	12.76	5.69	CL-3508-060-NRHI

HI-VIZ SUPERCRAFT HAMMERS — STEEL HANDLE

PART NO.	FACE DIA	WEIGHT (LBS)	OVERALL LENGTH	HEAD LENGTH	REPLACEMENT INSERT (2 REQUIRED)
CL-3377-130-NRH	30mm (1.18)	1.3	11.38	4.32	CL-3508-030-NRHI
CL-3377-140-NRH	40mm (1.57)	1.9	11.77	4.51	CL-3508-040-NRHI
CL-3377-150-NRH	50mm (1.96)	2.6	12.17	4.71	CL-3508-050-NRHI
CL-3377-160-NRH	60mm (2.36)	3.9	12.76	5.69	CL-3508-060-NRHI

HI-VIZ SUPERCRAFT HAMMERS — STEEL HANDLE

PART NO.	FACE DIA	WEIGHT (LBS)	OVERALL LENGTH	HEAD LENGTH	REPLACEMENT INSERT (2 REQUIRED)
CL-3380-040-NRH	30mm x 40mm (1.18 x 1.57)	1.6	11.77	4.59	CL-3511-040-NRHI

NO-REBOUND DROP HAMMERS

HOUSING: STEEL ASSEMBLY CONTAINING STEEL PELLETS
 INSERTS: NYLON, NATURAL WHITE COLOR, HARDNESS 68-78 SHORE D

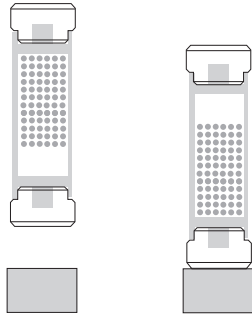

No-Rebound Drop Hammers are filled with special steel pellets that transfer momentum to the impact point.

No-Rebound Drop Hammers provide the impact of a normal hammer even when access is restricted. No-Rebound Hammers deliver full impact, about 50% greater than a standard hammer. The housing is filled with special steel pellets that transfer momentum to the impact point. Ideal for assembling machine parts without damage. Speeds up work while reducing fatigue. Allows better hammer control by absorbing the bounce. Available in four sizes .

No-Rebound Drop Hammers have replaceable nylon inserts. These nylon inserts are hard, grease and oil resistant, highly elastic, and have superior strike effectiveness. Applications include assembly operations, metalworking, tooling, positioning of workpieces, automotive assembly and repair work, joining of workpieces, sheet metal working, dent removal, mold construction, and assembly of sharp-edged workpieces.

PART NO.	FACE DIA	WEIGHT (LBS)	LENGTH	REPLACEMENT INSERT (2 REQUIRED)
CL-3408-020-NRH	20mm (.78)	0.5	5.89	CL-3508-020-NRHI
CL-3408-030-NRH	30mm (1.18)	1.0	6.08	CL-3508-030-NRHI
CL-3408-040-NRH	40mm (1.57)	1.8	6.28	CL-3508-040-NRHI
CL-3408-050-NRH	50mm (1.96)	2.8	6.48	CL-3508-050-NRHI

7

SOFT-FACE PUNCHES

HOUSING: STEEL. INSERTS: NYLON, NATURAL WHITE COLOR, HARDNESS 68-78 SHORE D



Soft-Face Punches safely extend the reach of a hammer when access is restricted. Transfers impact to difficult-to-reach places. Available in two sizes.

Soft-Face Punches have replaceable nylon inserts. These nylon inserts are hard, grease and oil resistant, highly elastic, and have superior strike effectiveness. Applications include assembly operations, metalworking, tooling, automotive assembly and repair work, joining of workpieces, sheet metal working, dent removal, and assembly of sharp-edged workpieces.

PART NO.	FACE DIA	WEIGHT (LBS)	LENGTH	REPLACEMENT INSERT (2 REQUIRED)
CL-3408-010-SFP	10mm (.39)	0.2	6.59	CL-3508-010-NRHI
CL-3408-015-SFP	15mm (.59)	0.4	6.87	CL-3508-015-NRHI

Need to configure a part? Try our **Part Configurator**

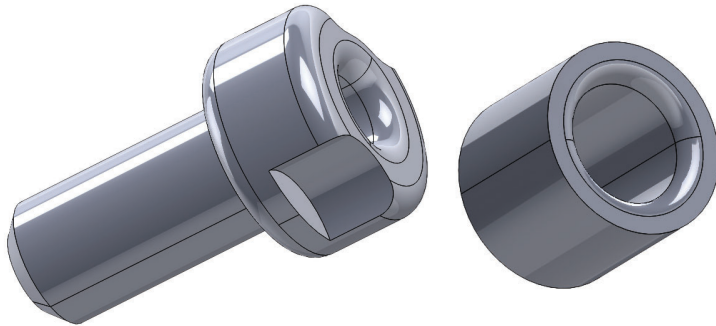

**Start Configuring
Parts Today!**



carrlane.com/configured-parts

7

Our Customer Service team is here to help



Ordering
Information

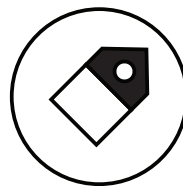

Price &
Availability



Request
A Quote



cs@carrlane.com
314.647.6200

THREADED INSERTS



Key Inserts – Heavy Duty



Key Inserts – Thinwall



Key Inserts – Solid



Key-Insert Installation Tools



Key-Insert Assortments



Adhesive-Bonded Fasteners

KEY INSERTS

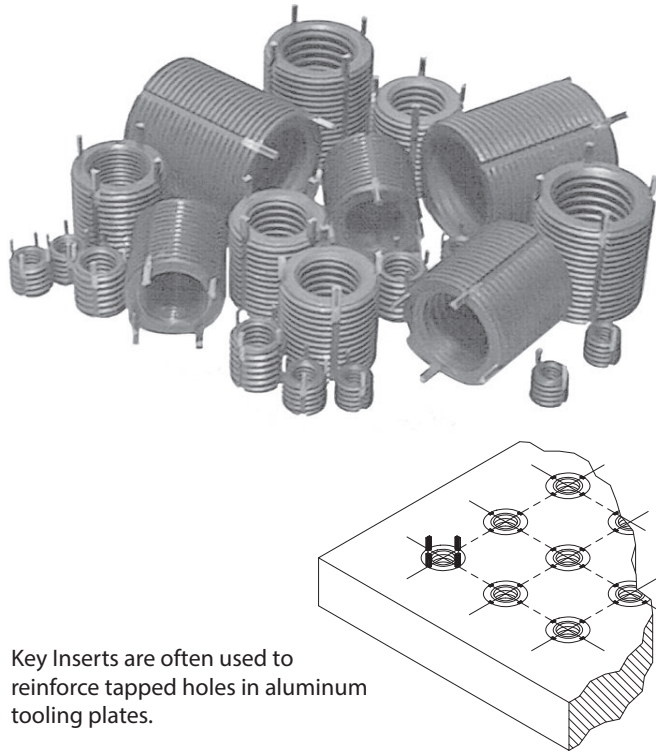

Key Inserts are often used to reinforce tapped holes in aluminum tooling plates.

These key-locking threaded inserts are ideal for thread reinforcement, especially when the mating stud or bolt will be removed frequently. They provide strong, permanent steel threads in any parent material — ferrous, non-ferrous, or non-metallic.

Key Inserts are also well suited for quick repair of stripped, damaged, or worn threads. A solid version is also available to use as a handy plug to relocate holes drilled or tapped on the wrong location.

Install with standard drills and taps. Important: Use tap drill specified in table (slightly larger than standard for that thread size). Tap-drill hole tolerance should be $-.001/+0.004$ ($-.001/+0.005$ above .500 dia).

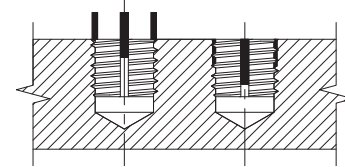

Locking keys are driven down into the parent material during installation, providing a positive mechanical lock against rotation. Inserts with an ID thread 5/16 and above have four locking keys, smaller sizes have two. Pull-out strength can be calculated approximately by the following formula:

$$\text{Approximate pull-out strength} = \text{Shear engagement area of insert (see table)} \times \text{Minimum ultimate shear strength of parent material (psi)}$$

EASY INSTALLATION

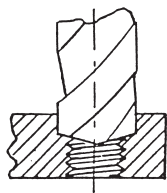

1. Drill out old threads using tap drill specified in table (Important: Correct tap drill is slightly larger than standard for that thread size).

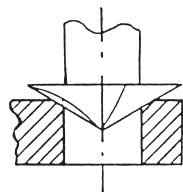

2. Countersink to diameter shown in table.

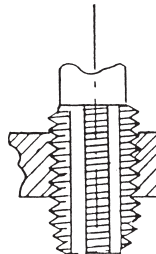

3. Tap new threads, using standard tap.



4. Screw in insert until body is slightly (.010 to .030 inches) below the surface, by hand or using installation tool. Keys act as a depth stop.

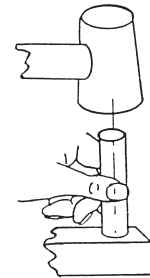

5. Drive keys down with several light hammer taps on installation tool (or directly on keys if no installation tool is available).

EASY REMOVAL

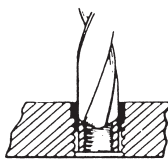

1. Drill out locking keys with specified drill diameter and depth (see table).

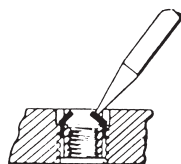

2. Deflect keys inward and break off.

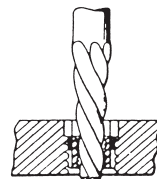

3. Remove insert with an E-Z OUT type tool.

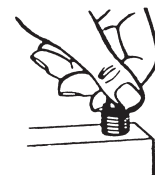

4. Screw replacement into original holes. Parent material is totally undamaged.

KEY INSERTS – HEAVY DUTY

BODY: 1215 STEEL, BLACK OXIDE FINISH. KEYS: 302 STAINLESS STEEL



Heavy Duty – Steel

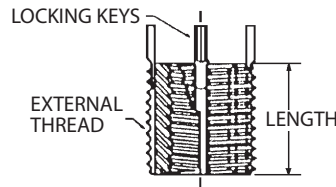

For installation tools, see tables below.

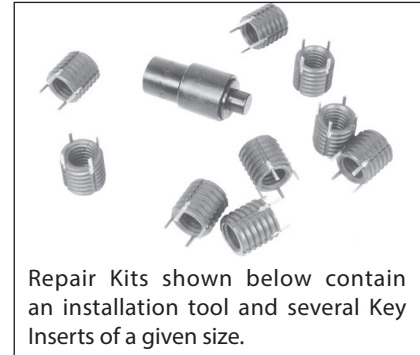

Repair Kits shown below contain an installation tool and several Key Inserts of a given size.

General-purpose threaded inserts suitable for most applications. Available in USA ID-thread sizes from #10-24 to 1-1/2"-12, plus metric sizes from M5 to M24. Important: Use tap drill specified in table (slightly larger than standard for that thread size).

HEAVY DUTY – STEEL (INCH)

PART NO.	INSERT DIMENSIONS				INSTALLATION DATA							REMOVAL DATA	
	INTERNAL THREAD	EXTERNAL THREAD	LENGTH	SHEAR ENGAG. (SQ. IN.)	REQ'D TAP DRILL	C'SINK DIA	MIN. THREAD DEPTH	STANDARD TAP UN-2B	INSTALLATION TOOL PART NO.	REPAIR KIT PART NO.	INSERTS PER KIT	DRILL SIZE	DRILL DEPTH
CL-1024-KS	#10-24	3/8-16	.31	.190	Q	3/8	3/8	3/8-16	CL-10-KST	CL-1024-KSK	15	9/32	1/8
CL-1032-KS	#10-32									CL-1032-KSK			
CL-1420-KS	1/4-20	7/16-14	.37	.284	X	7/16	7/16	7/16-14	CL-14-KST	CL-1420-KSK	13	11/32	3/16
CL-1428-KS	1/4-28									CL-1428-KSK			
CL-51618-KS	5/16-18	1/2-13	.43	.359	29/64	1/2	1/2	1/2-13	CL-516-KST	CL-51618-KSK	8	13/32	3/16
CL-51624-KS	5/16-24									CL-51624-KSK			
CL-3816-KS	3/8-16	9/16-12	.50	.498	33/64	9/16	9/16	9/16-12	CL-38-KST	CL-3816-KSK	6	15/32	3/16
CL-3824-KS	3/8-24									CL-3824-KSK			
CL-71614-KS	7/16-14	5/8-11	.62	.717	37/64	5/8	11/16	5/8-11	CL-716-KST	CL-71614-KSK	6	17/32	3/16
CL-71620-KS	7/16-20									CL-71620-KSK			
CL-1213-KS	1/2-13	3/4-16	.62	1.057	45/64	3/4	11/16	3/4-16	CL-12-KST	CL-1213-KSK	5	21/32	3/16
CL-1220-KS	1/2-20									CL-1220-KSK			
CL-91612-KS	9/16-12	3/4-16	.81	1.057	45/64	3/4	7/8	3/4-16	CL-12-KST	CL-91612-KSK	3	21/32	3/16
CL-91618-KS	9/16-18									CL-91618-KSK			
CL-5811-KS	5/8-11	7/8-14	.87	1.487	53/64	7/8	1	7/8-14	CL-58-KST	CL-5811-KSK	2	25/32	3/16
CL-5818-KS	5/8-18									CL-5818-KSK			
CL-3410-KS	3/4-10	1-1/8"-12	1.12	2.490	1-1/16	1-1/8	1-5/16	1-1/8"-12	CL-34-KST	CL-3410-KSK	2	31/32	5/16
CL-3416-KS	3/4-16									CL-3416-KSK			
CL-789-KS	7/8-9	1-1/4"-12	1.25	3.137	1-3/16	1-1/4	1-7/16	1-1/4"-12	CL-34-KST	CL-789-KSK	2	1-3/32	5/16
CL-7814-KS	7/8-14									CL-7814-KSK			
CL-18-KS	1"-8	1-3/8"-12	1.37	3.838	1-5/16	1-3/8	1-9/16	1-3/8"-12	CL-1-KST	CL-18-KSK	2	1-7/32	5/16
CL-112-KS	1"-12									CL-112-KSK			
CL-1187-KS	1-1/8"-7	1-1/2"-12	1.62	4.752	1-7/16	1-1/2	1-11/16	1-1/2"-12	CL-118-KST	CL-1187-KSK	2	1-11/32	5/16
CL-11812-KS	1-1/8"-12									CL-11812-KSK			
CL-1147-KS	1-1/4"-7	1-5/8"-12	1.81	5.446	1-35/64	1-5/8	2	1-5/8"-12	CL-114-KST	CL-1147-KSK	2	1-15/32	5/16
CL-11412-KS	1-1/4"-12									CL-11412-KSK			
CL-1126-KS	1-1/2"-6	1-7/8"-12	2.00	7.103	1-51/64	1-7/8	2-3/16	1-7/8"-12	CL-112-KST	CL-1126-KSK	2	1-23/32	5/16
CL-11212-KS	1-1/2"-12									CL-11212-KSK			

HEAVY DUTY – STEEL (METRIC)

-	M5	M10x1.25	INFO+: AVAILABLE IN STAINLESS STEEL ONLY (PAGE 345)										
-	M6	M12x1.25											
-	M8	M14x1.5											
-	M8x1												
-	M10	M16x1.5											
-	M10x1.25												
-	M12	M18x1.5											
-	M12x1.25												
CLM-162-KSM	M16	M22x1.5	.87	1.390	20.5 or 13/16	.88	.96	M22x1.5	CL-58-KST	CLM-162-KSK	2	17.5mm or 11/16	1/4
CLM-1615-KSM	M16x1.5		CLM-1615-KSK										
CLM-2025-KSM	M20	M30x2	1.18	2.750	28mm or 1-7/64	1.19	1.36	M30x2	CL-34-KST	CLM-2025-KSK	2	26mm or 1-1/32	1/4
CLM-2015-KSM	M20x1.5		CLM-2015-KSK										
CLM-243-KSM	M24	M33x2	1.30	3.328	31mm or 1-7/32	1.31	1.48	M33x2	CLM-243-KSMT	CLM-243-KSK	2	29mm or 1-9/64	1/4
CLM-242-KSM	M24x2		CLM-242-KSK										

* Installation Tool included in Repair Kit.

CONTINUED ON NEXT PAGE

KEY INSERTS – HEAVY DUTY

BODY: 303 STAINLESS STEEL. KEYS: 302 STAINLESS STEEL



**Heavy Duty –
Stainless Steel**

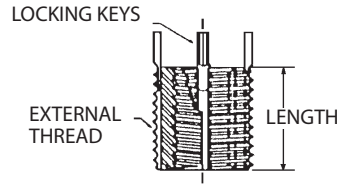

Stainless steel version of our general-purpose threaded inserts with a thick, heavy-duty thread wall. Key Inserts are ideal for thread reinforcement, especially when the mating stud or bolt will be removed frequently. These stainless inserts provide strong, permanent stainless steel threads in any parent material, ferrous, non-ferrous, or non-metallic. Key Inserts are also well suited for quick repair of stripped, damaged, or worn threads. Locking keys positively prevent the insert from rotating.



**Heavy Duty –
Stainless Steel
Internal-Thread
Locking**

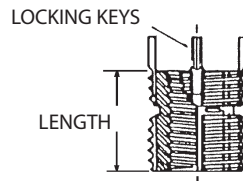

Stainless Key Inserts are optionally available with “Internal Thread Locking,” which uses a modified internal thread to prevent the installed bolt or stud from rotating. This feature is useful for one-time, permanent installations.

See Technical Information at the beginning of this section for complete installation steps. Key Inserts are installed with standard drills and taps. Important: Use exactly the tap-drill size specified in the tables (slightly larger than the standard tap drill for that thread size). Locking keys are driven down into the parent material during installation, providing a positive mechanical lock against rotation. See tables for optional installation tools.

KEY INSERTS — HEAVY DUTY, STAINLESS STEEL (INCH)

PART NO.	INTERNAL THREAD	EXTERNAL THREAD	LENGTH	SHEAR ENGAGEMENT AREA (sq in)	MS EQUIVALENT	NAS EQUIVALENT
CL-1024-SKS	#10-24	3/8-16	.31	.190	MS 51831-101	—
CL-1032-SKS	#10-32				MS 51831-201	NAS 1395C3
CL-1420-SKS	1/4-20	7/16-14	.37	.284	MS 51831-102	—
CL-1428-SKS	1-4/28				MS 51831-202	NAS 1395C4
CL-51618-SKS	5/16-18	1/2-13	.43	.359	MS 51831-103	—
CL-51624-SKS	5/16-24				MS 51831-203	NAS 1395C5
CL-3816-SKS	3/8-16	9/16-12	.50	.498	MS 51831-104	—
CL-3824-SKS	3/8-24				MS 51831-204	NAS 1395C6
CL-1213-SKS	1/2-13	3/4-16	.62	1.057	—	—
CL-1220-SKS	1/2-20				—	—
CL-5811-SKS	5/8-11	7/8-14	.87	1.487	MS 51831-108	—
CL-3410-SKS	3/4-10	1-1/8"-12	1.12	2.490	MS 51831-109	—

KEY INSERTS — HEAVY DUTY, STAINLESS STEEL (METRIC)

PART NO.	INTERNAL THREAD	INTERNAL THREAD PITCH (mm)	EXTERNAL THREAD	EXTERNAL THREAD PITCH (mm)	LENGTH (mm)	SHEAR ENGAGEMENT AREA (sq mm)
CLM-58-SKSM	M5	.8	M10x1.25	1.25	10	177
CLM-61-SKSM	M6	1	M12x1.25		12	266
CLM-8125-SKSM	M8	1.25	M14x1.5	1.5	14	342
CLM-81-SKSM	M8x1	1			16	470
CLM-1015-SKSM	M10	1.5	M16x1.5	1.5	16	470
CLM-10125-SKSM	M10x1.25	1.25			18	529
CLM-12175-SKSM	M12	1.75	M18x1.5	1.5	18	529
CLM-12125-SKSM	M12x1.25	1.25			22	897
CLM-162-SKSM	M16	2	M22x1.5	2	22	897
CLM-2025-SKSM	M20	2.5	M30x2		30	1770
CLM-243-SKSM	M24	3	M33x2	2	33	2150

KEY INSERTS – THINWALL

BODY: 12L15 STEEL, BLACK OXIDE FINISH, OR 303 STAINLESS STEEL.
KEYS: 302 STAINLESS STEEL



**Thinwall —
Steel and
Stainless Steel**

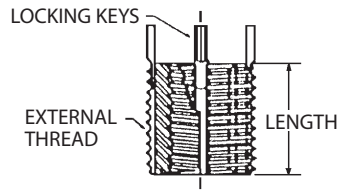

Thinwall Key Inserts have a smaller OD thread size than standard heavy-duty inserts, ideal for tight spaces where less pull-out strength is acceptable. Key Inserts are ideal for thread reinforcement, especially when the mating stud or bolt will be removed frequently. These stainless inserts provide strong, permanent stainless steel threads in any parent material, ferrous, non-ferrous, or non-metallic. Key Inserts are also well suited for quick repair of stripped, damaged, or worn threads. Locking keys positively prevent the insert from rotating.



**Thinwall —
Stainless Steel
Internal-Thread
Locking**

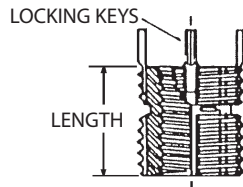

Stainless Key Inserts are optionally available with “Internal Thread Locking,” which uses a modified internal thread to prevent the installed bolt or stud from rotating. This feature is useful for one-time, permanent installations.

See Technical Information at the beginning of this section for complete installation steps. Key Inserts are installed with standard drills and taps. Important: Use exactly the tap-drill size specified in the tables (slightly larger than the standard tap drill for that thread size). Locking keys are driven down into the parent material during installation, providing a positive mechanical lock against rotation. See tables for optional installation tools.

THINWALL, STEEL (INCH)

PART NO.	INTERNAL THREAD	INTERNAL THREAD PITCH (mm)	EXTERNAL THREAD	EXTERNAL THREAD PITCH (mm)	LENGTH (mm)	SHEAR ENGAGEMENT AREA (sq mm)
CLM-58-KSM	M5	.8	M8	1.25	8	105
CLM-61-KSM	M6	1	M10x1.25		10	177
CLM-8125-KSM	M8	1.25	M12x1.25		12	266
CLM-81-KSM	M8x1	1		14	342	
CLM-1015-KSM	M10	1.5	M16x1.5	1.5	14	342
CLM-10125-KSM	M10x1.25	1.25			16	470
CLM-12175-KSM	M12	1.75			16	470
CLM-12125-KSM	M12x1.25	1.25				

THINWALL, STAINLESS STEEL (METRIC)

CLM-58-SKS	M5	.8	M8	1.25	8	105
CLM-61-SKS	M6	1	M10x1.25		10	177
CLM-8125-SKS	M8	1.25	M12x1.25		12	266
CLM-81-SKS	M8x1	1		14	342	
CLM-1015-SKS	M10	1.5	M16x1.5	1.5	14	342
CLM-10125-SKS	M10x1.25	1.25			16	470
CLM-12175-SKS	M12	1.75			16	470
CLM-12125-SKS	M12x1.25	1.25				

KEY INSERTS – SOLID

BODY: 1215 STEEL, BLACK OXIDE FINISH, OR 303 STAINLESS STEEL.
KEYS: 302 STAINLESS STEEL



**Solid –
Steel and
Stainless Steel**

Solid Key Inserts are ideal for relocating a drilled or tapped hole. This threaded plug installs quickly, and the locking keys positively prevent the insert from rotating.

See Technical Information at the beginning of this section for complete installation steps. Key Inserts are installed with standard drills and taps. Important: Use exactly the tap-drill size specified in the tables (slightly larger than the standard tap drill for that thread size). Locking keys are driven down into the parent material during installation, providing a positive mechanical lock against rotation. See tables for optional installation tools.

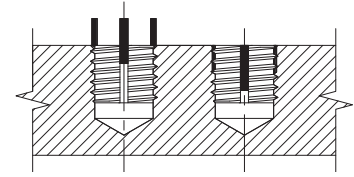

For installation tools, see table below.

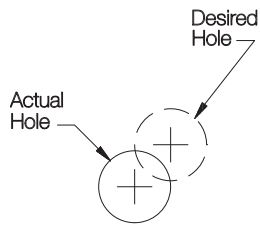

Before Repair

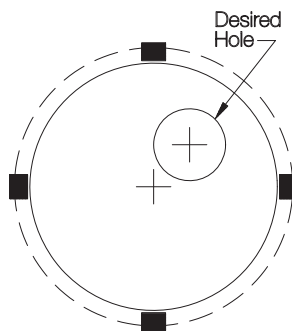

After Repair

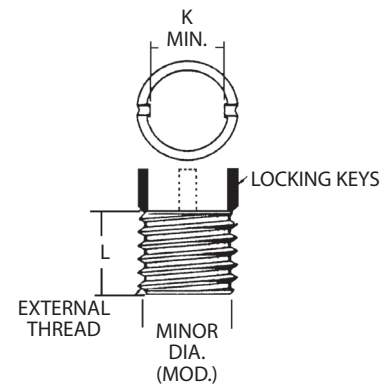

SOLID – STAINLESS STEEL (INCH)

PART NO.	INSERT DIMENSIONS				SHEAR ENGAGEMENT (SQ. IN.)	REQ'D TAP DRILL	C'SINK DIA +.010/-.000	INSTALLATION DATA			REMOVAL DATA	
	EXTERNAL THREAD	L	K					STANDARD TAP UN-2B	MIN. THREAD DEPTH	INSTALLATION TOOL PART NO.	DRILL SIZE	DRILL DEPTH
CL-51618-KSS	5/16-18	.31	.216	.152	.152	I	.323	5/16-18	.37	CL-51618-KSST	7/32	1/8
CL-3816-KSS	3/8-16	.31	.285	.190	.190	Q	.385	3/8-16	.37	CL-3816-KSST	9/32	1/8
CL-71614-KSS	7/16-14	.37	.341	.284	.284	X	.447	7/16-14	.43	CL-71614-KSST	11/32	3/16
CL-1213-KSS	1/2-13	.43	.403	.359	.359		.510	1/2-13	.50	CL-1213-KSST	13/32	3/16
CL-91612-KSS	9/16-12	.50	.465	.498	.498		.572	9/16-12	.56	CL-91612-KSST	15/32	3/16
CL-5811-KSS	5/8-11	.62	.528	.717	.717		.635	5/8-11	.68	CL-5811-KSST	17/32	3/16
CL-111611-KSS	11/16-11-NS	.68	.590	.888	.888		.700	11/16-11-NS	.75	CL-111611-KSST	19/32	3/16
CL-131616-KSS	13/16-16	.81	.716	1.249	1.249		.822	13/16-16	.94	CL-131616-KSST	23/32	3/16
CL-7814-KSS	7/8-14	.87	.778	1.487	1.487		.885	7/8-14	1.00	CL-7814-KSST	25/32	3/16
CL-11812-KSS	1-1/8"-12	1.12	.970	2.490	2.490		1.145	1-1/8"-12	1.31	CL-11812-KSST	31/32	5/16
CL-11412-KSS	1-1/4"-12	1.25	1.095	3.137	3.137		1.270	1-1/4"-12	1.41	CL-11412-KSST	1-3/32	5/16
CL-13812-KSS	1-3/8"-12	1.37	1.220	3.838	3.838		1.395	1-3/8"-12	1.56	CL-13812-KSST	1-7/32	5/16

SOLID – STEEL (METRIC)

PART NO.	EXTERNAL THREAD	EXTERNAL THREAD PITCH (mm)	L LENGTH (mm)	K MINIMUM (mm)	SHEAR ENGAGEMENT AREA (sq mm)
CLM-8125-KSSM	M8	1.25	8	5.5	99
CLM-10125-KSSM	M10x1.25		10	7.5	135
CLM-12125-KSSM	M12x1.25		12	9	214
CLM-1615-KSSM	M16x1.5	1.5	16	13.5	470
CLM-2015-KSSM	M20x1.5		20	17.5	757
CLM-2415-KSSM	M24x1.5		24	20.5	1130
CLM-302-KSSM	M30x2	2	30	26	1800

KEY INSERT ASSORTMENTS



With Key Insert Assortments, you always have the right insert and installation tool on hand for thread repairs. Each of the four assortments contains many different insert sizes and an installation tool for each size. The durable case provides convenient storage and clear organization. **INFO+:** Order individual inserts on pages 344-348 as refills.

UNC COARSE

PART NO.	CONTAINS THESE INSERTS			CONTAINS THESE TOOLS
	QTY	ID THREAD	PART NO.	
CL-1-KS-C	5	#10-24	CL-1024-KS	CL-10-KST
	10	1/4-20	CL-1420-KS	CL-14-KST
	10	5/16-18	CL-51618-KS	CL-516-KST
	10	3/8-16	CL-3816-KS	CL-38-KST
	10	1/2-13	CL-1213-KS	CL-12-KST
	5	5/8-11	CL-5811-KS	CL-58-KST
	5	3/4-10	CL-3410-KS	CL-34-KST

UNC COARSE — STAINLESS STEEL

PART NO.	CONTAINS THESE INSERTS			CONTAINS THESE TOOLS
	QTY	ID THREAD	PART NO.	
CL-1-SKS-C	5	#10-24	CL-1024-KS	CL-10-KST
	10	1/4-20	CL-1420-KS	CL-14-KST
	10	5/16-18	CL-51618-KS	CL-516-KST
	10	3/8-16	CL-3816-KS	CL-38-KST
	10	1/2-13	CL-1213-KS	CL-12-KST
	10	5/8-11	CL-5811-KS	CL-58-KST
	5	3/4-10	CL-3410-KS	CL-34-KST

UNF FINE

PART NO.	CONTAINS THESE INSERTS			CONTAINS THESE TOOLS
	QTY	ID THREAD	PART NO.	
CL-1-KS-F	5	#10-24	CL-1032-KS	CL-10-KST
	10	1/4-20	CL-1428-KS	CL-14-KST
	10	5/16-18	CL-51624-KS	CL-516-KST
	10	3/8-16	CL-3824-KS	CL-38-KST
	10	1/2-13	CL-1220-KS	CL-12-KST
	10	5/8-11	CL-5818-KS	CL-58-KST
	5	3/4-10	CL-3416-KS	CL-34-KST

METRIC COARSE

PART NO.	CONTAINS THESE INSERTS			CONTAINS THESE TOOLS
	QTY	ID THREAD	PART NO.	
CLM-1-KSM-C	5	M5	CLM-58-KSM	CL-10-KST
	10	M6	CLM-61-KSM	CL-14-KST
	10	M8	CLM-8125-KSM	CL-516-KST
	10	M10	CLM-1015-KSM	CL-38-KST
	10	M12	CLM-12175-KSM	CL-12-KST
	10	M16	CLM-162-KSM	CL-58-KST
	5	M20	CLM-2025-KSM	CL-34-KST

SOLID — STAINLESS STEEL

PART NO.	CONTAINS THESE INSERTS			CONTAINS THESE TOOLS
	QTY	ID THREAD	PART NO.	
CL-1-KSS-S	5	5/16-18	CL-51618-KSS	CL-51618-KSST
	10	3/8-16	CL-3816-KSS	CL-3816-KSST
	10	1/2-13	CL-1213-KSS	CL-1213-KSST
	10	9/16-12	CL-91612-KSS	CL-91612-KSST
	10	5/8-11	CL-5811-KSS	CL-5811-KSST
	10	7/8-14	CL-7814-KSS	CL-7814-KSST
	5	1-1/8"-12	CL-11812-KSS	CL-11812-KSST



INFO+: To order repair kits for a single thread size, see page 344.

ADHESIVELY BONDED FASTENERS

STUDS & FLOATING NUT PLATES: 304 STAINLESS STEEL
LANYARD MOUNT: PLASTIC

New Adhesively Bonded Fastener System!

This unique system of fasteners is designed to be adhesively bonded to almost any substrate – metal, plastic, or composite. This wide range of fasteners includes studs, floating nut plates, and lanyard mounts. The heart of this fastener system is our WELD MOUNT® No-Slide Adhesive, which is specifically formulated to be used with our adhesively bonded fasteners. This unique structural adhesive is a high-strength, high-viscosity methacrylate with incredible strength in both tension and shear, designed to hold any of our adhesively bonded fasteners without sliding or sagging, even on a vertical or overhead surface, with no need for fixturing.



Adhesively Bonded Studs



Our Adhesively Bonded Studs are heavy-duty structural parts that provide considerable tensile and shear strength. These studs can be attached to virtually any metal, plastic, or composite surface using our acrylic adhesive. They can be bonded on either surface of the base plate, bottom or top. Made of 304 stainless steel for excellent corrosion resistance. The largest two sizes are inertial (friction) welded to a 2" base plate, creating a very strong part with 1200 lbs tensile strength and 1500 lbs shear strength.

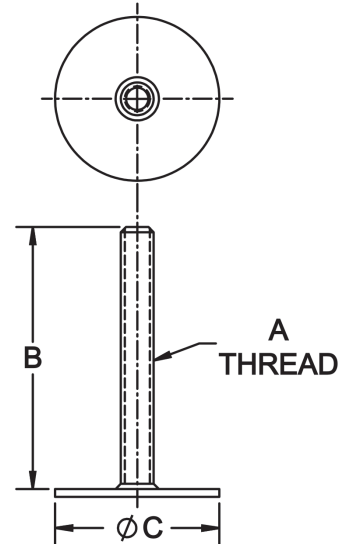

ADHESIVELY BONDED STUDS

PART NO.	A THREAD	B	C DIA	TENSILE STRENGTH (LBS)	SHEAR STRENGTH (LBS)
CL-1024-ABS-1.00-S	#10-24	1	1-1/4	500	650
CL-1420-ABS-1.50-S	1/4-20	1-1/2	1-1/4	500	650
CL-51618-ABS-1.50-S	5/16-18	1-1/2	2	1200	1500
CL-3816-ABS-2.00-S	3/8-16	2	2	1200	1500

WELD MOUNT® is a registered trademark of Royal Adhesives and Sealants, LLC.

ADHESIVELY BONDED FASTENERS

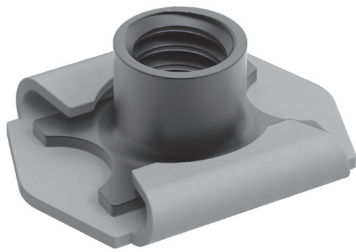

Adhesively Bonded Floating Nut Plates

Floating Nut Plates have a captive threaded nut that floats to allow for accurate bolt alignment. Our adhesively bonded nut plates eliminate tapping. These nut plates can be used for either through-hole or blind-hole applications. Made of 304 stainless steel for excellent corrosion resistance. An included rubber fixture insert holds the nut plate stationary while it is bonded in place with acrylic adhesive, keeping the threads clean during installation. Remove the rubber fixture when you are ready to make up the assembly.

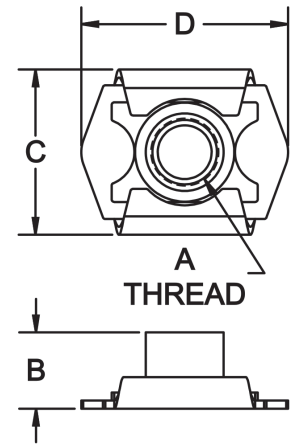
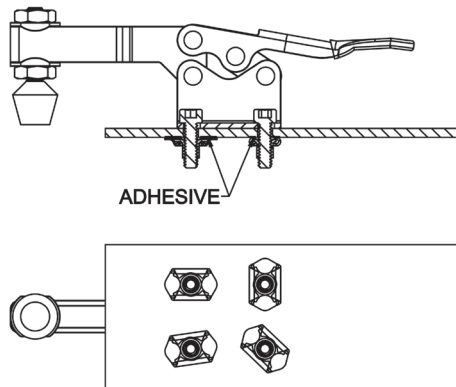

ADHESIVELY BONDED FLOATING NUT PLATES

PART NO.	A THREAD	B	C	D
CL-1024-FNP-S	#10-24	.24	.43	.73
CL-1420-FNP-S	1/4-20	.30	.50	.79

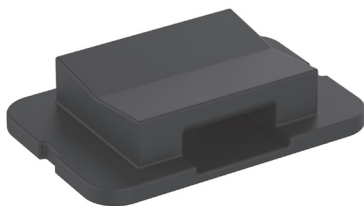

Adhesively Bonded Lanyard Mounts

This heavy-duty lanyard mount is designed to be bonded with our acrylic adhesive, eliminating drilling, blocking, and tapping operations. Provides an excellent average pull strength of 150 lbs. These lanyard mounts fit wire-rope cable lanyards up to .094" diameter (#3) or wire ties up to .35" wide (#5).

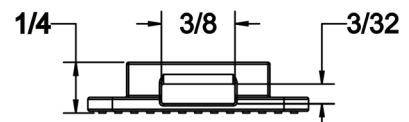
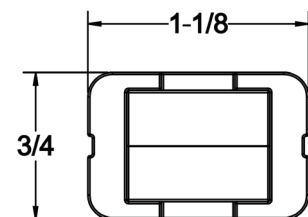

ADHESIVELY BONDED LANYARD MOUNTS

PART NO. (PACK OF 10)	MAXIMUM LANYARD CABLE DIA	MAXIMUM WIRE-TIE WIDTH	AVERAGE PULL STRENGTH (LBS)
CL-5G-ABT-PACKOF10	.094 (#3)	.35	150

ADHESIVELY BONDED FASTENERS

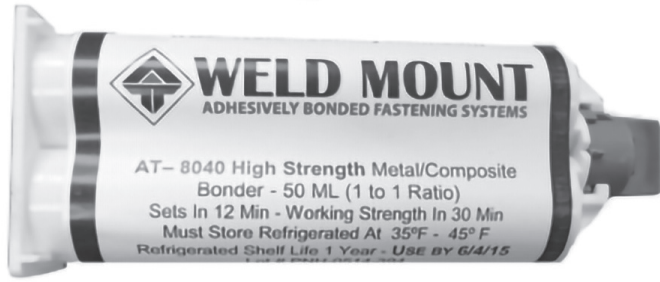

WELD MOUNT® No-Slide Adhesive

WELD MOUNT® No-Slide Adhesive

This unique structural adhesive is specifically formulated to be used with our adhesively bonded fasteners. Adhesive CL-AT-8040 is a high-strength, high-viscosity methacrylate with incredible strength in both tension and shear, designed to hold any of our adhesively bonded fasteners without sliding or sagging, even on a vertical or overhead surface, with no need for fixturing.

CL-AT-8040 is a solvent-free, VOC-compliant, two-part methacrylate-based, structural adhesive formulated to bond metals, engineered thermoplastics and thermosetting plastics, and composites to most metal and composite substrates. It has excellent adhesion to metal surfaces including aluminum, stainless steel, galvanized steel, and plated steels. CL-AT-8040 forms a tough high-strength bond, with minimal surface preparation required, developing handling strength in 12 minutes and a functional cure within 45 minutes, making it ideal for production applications. Shear strength exceeds 3500 psi on aluminum, with remarkable impact and peel strengths. Comprehensive Care & Use Instructions are included with this product and can be found at www.carrlane.com. Note: this product ships to USA and Canada only, via air freight.

WELD MOUNT® NO-SLIDE ADHESIVE

PART NO.	CARTRIDGE SIZE	MIXING RATIO	REQUIRED DISPENSING GUN	REQUIRED MIXING TIP
CL-AT-8040	50ml	1:1	CL-AT-300	CL-AT-850



Adhesive Dispensing Gun

This dispensing gun is designed specifically for use with our WELD MOUNT® two-part adhesive CL-AT-8040, with dual plungers to mix at a 1:1 ratio.

ADHESIVE DISPENSING GUN

PART NO.	TYPE	MIXING RATIO
CL-AT-300	Dual plunger	1:1



Adhesive Mixing Tip

This 3.5"-long mixing tip is designed specifically for dispensing our CL-AT-8040 two-part adhesive using our CL-AT-300 Adhesive Dispensing Gun. Its unique design eliminates any possibility of the cartridge plugging up as the entry is separated. Sold in pack of 3.

ADHESIVE MIXING TIP

PART NO.	LENGTH
CL-AT-850-PACKOF3	3.5

ADHESIVELY BONDED FASTENERS

SIMPLE INSTALLATION

1

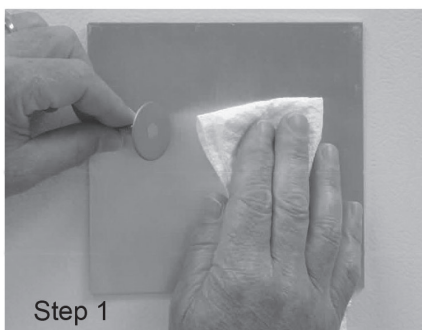

Step 1
Clean fastener and substrate with Scotchbrite (light scuff) and solvent.

5

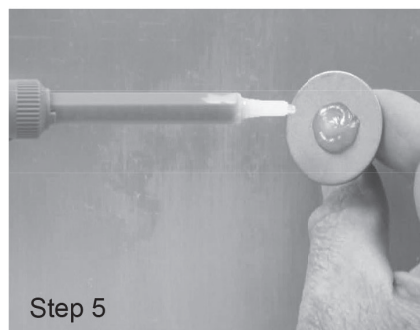

Step 5
Put a large drop of adhesive in the center of the part base.

2

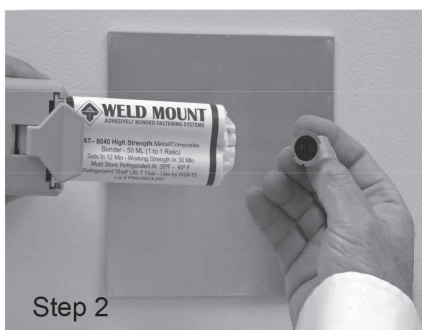

Step 2
Cap can only be installed one way, preventing cross contamination.

6



Step 6
Push part into the substrate to squeeze adhesive out from base.

8

3

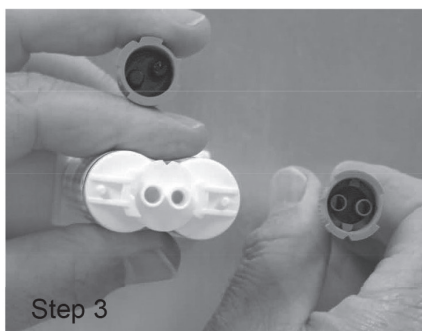

Step 3
New cartridge design insures easy reuse of the adhesive.

7



Step 7
Slowly turn part clockwise while pushing until it won't turn.

4

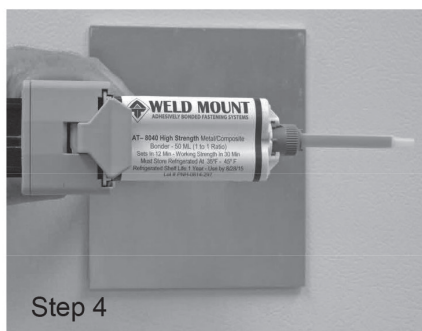

Step 4
Fit tip onto CL-AT-8040 cartridge.



Traditional
Acrylic
Adhesive

CL-AT-8040
No Slide
Adhesive

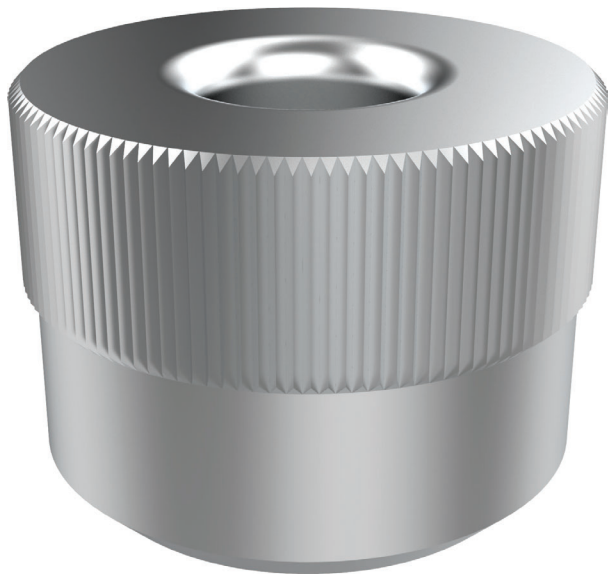

Quick-Ship Bushings

In-Stock and Ready for Same-Day Shipping



5-Axis Vises

Allows unrestricted tool access for multiple-side machining.

carrlane.com/cl5



8

JIG AND FIXTURE BASES



Carr Lock® System



**CL5® Quick-Change
5-Axis Workholding**

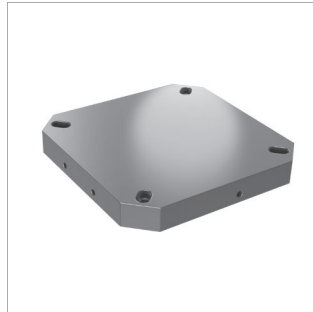

Blank Tooling Plates



Blank Tooling Blocks

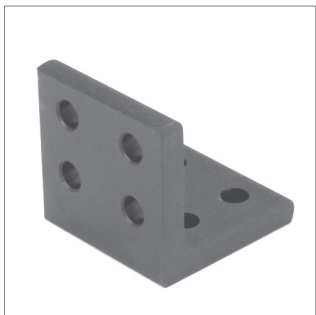

Angle Brackets



Cast Sections



Hinged Bushing Plates

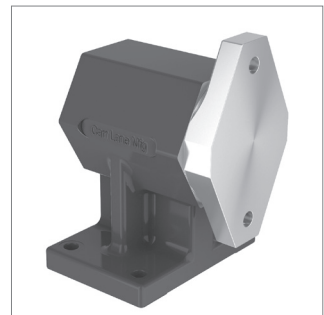

Trunnions



Adjustable Locking Hubs

9

Also see:

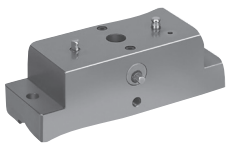

**Quintus Zero-Point
Quick-Change Risers**
p. 373



**CARVESMART™
Dovetailed Quick-Change
Vise Jaw System**
SEE WEBSITE



**Modular Tooling
Plates & Blocks**
p. 402

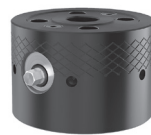

**DropZero™ Modular
Zero-Point System**
p. 658-661



Precision Vises
p. 644-647



**Assembly & Handling
Technology**
p. 720

CARR LOCK® SYSTEM

CLAMP BODY: 4340 STEEL, HEAT TREATED RC 40-45, BLACK OXIDE FINISH
 RECEIVER BUSHINGS: 4340 STEEL, HEAT TREATED RC 50-54, BLACK OXIDE FINISH
 LINERS: 1144 OR TOOL STEEL, HEAT TREATED RC 58-64, BLACK OXIDE FINISH



Carr Lock® Clamp

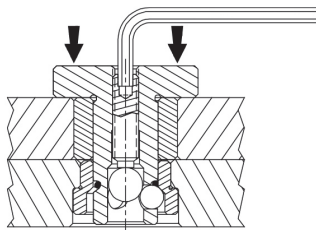

Turning the clamping screw with a hex wrench advances the large center ball, pushing the three clamping balls outward. These balls engage the angled ID of the Receiver Bushing, pulling the entire unit firmly downward.

The Carr Lock® System allows accurately locating and clamping at the same time, with just the turn of a hex wrench. Ideal for mounting quick-change tooling on a subplate. Each mount consists of three components: (1) a Carr Lock® Clamp with a precisely ground shank; (2) a Liner Bushing in the top plate; (3) a Receiver Bushing in the subplate. This compact assembly provides considerable holddown force, together with an incredible $\pm .0005$ inches repeatability!

Each top plate should have one Carr Lock® Clamp designated as its primary reference point, and one as its secondary reference point. These two clamps should be as far apart as possible. The secondary reference point should have a relieved liner to avoid redundant location (binding). Additional Carr Lock® Clamps can be used for more clamping force, but these should be installed in clearance holes, not locating liners. Note that the same Carr Lock® Clamp fits any type of liner or a clearance hole.

Carr Lock® Clamps must be used with one of the Receiver Bushings (INFO+) on page 356. Plate thickness must be $\pm .005$ inches to achieve proper clamping force. Special grip lengths for other plate thicknesses are available as specials. Do not exceed maximum screw torque shown.

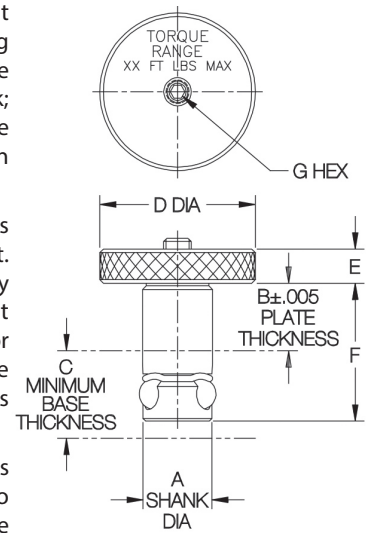

CARR LOCK® CLAMPS (INCH)

PART NO.	A SHANK DIA		B		C	D DIA	E	F	G	MAX SCREW TORQUE (FT-LBS)	MAX HOLD-DOWN FORCE (LBS)	SPARE PARTS KIT PART NO.*
	NOMINAL	ACTUAL	NOMINAL	ACTUAL								
CL-13-CLC-0.50	13mm	.5116	1/2	.500	.75	7/8	1/4	1.08	3/32	1	750	CL-13-CLPK-0.50
CL-13-CLC-0.75		.5111	3/4	.750				1.33				CL-13-CLPK-0.75
CL-16-CLC-0.50	16mm	.6297	1/2	.500	.75	1-1/2	5/16	1.15	1/8	2	1200	CL-16-CLPK-0.50
CL-16-CLC-0.75		.6292	3/4	.750				1.40				CL-16-CLPK-0.75
CL-20-CLC-0.75	20mm	.7872	3/4	.750	.83	1-3/4	3/8	1.53	1/8	3	3000	CL-20-CLPK-0.75
CL-20-CLC-1.00		.7867	1	1.000				1.78				CL-20-CLPK-1.00
CL-25-CLC-0.75	25mm	.9841	3/4	.750	1.00	2	3/8	1.70	5/32	7	7000	CL-25-CLPK-0.75
CL-25-CLC-1.00		.9836	1	1.000				1.95				CL-25-CLPK-1.00
CL-30-CLC-0.75	30mm	1.1809	3/4	.750	1.23	2-1/4	1/2	1.88	3/16	12	10000	CL-30-CLPK-0.75
CL-30-CLC-1.00		1.1804	1	1.000				2.13				CL-30-CLPK-1.00
CL-35-CLC-0.75	35mm	1.3778	3/4	.750	1.28	2-1/4	1/2	1.97	1/4	19	15500	CL-35-CLPK-0.75
CL-35-CLC-1.00			1	1.000				2.22				CL-35-CLPK-1.00
CL-35-CLC-1.50			1-1/2	1.500				2.72				CL-35-CLPK-1.50
CL-35-CLC-2.00			2	2.000				3.22				CL-35-CLPK-2.00
CL-50-CLC-1.00	50mm	1.9683	1	1.000	1.80	3	3/4	2.70	3/8	38	20000	CL-50-CLPK-1.00
CL-50-CLC-1.50			1-1/2	1.500				3.20				CL-50-CLPK-1.50
CL-50-CLC-2.00			2	2.000				3.70				CL-50-CLPK-2.00

CARR LOCK® CLAMPS (METRIC)

PART NO.	A SHANK DIA NOMINAL (mm)	A SHANK DIA ACTUAL (mm)	B PLATE THICKNESS (mm)	C (mm)	D DIA (mm)	E (mm)	F (mm)	G (mm)	MAX SCREW TORQUE (Nm)	MAX HOLD-DOWN FORCE (kN)
CLM-13-CLC-13	13mm	12.995/	13mm	20	22	6	28	2.5	1.4	3.3
CLM-13-CLC-20		12.982	20mm				34.5			
CLM-16-CLC-20	16mm	15.995/	20mm	26	38	8	36.5	3	2.7	5.3
CLM-16-CLC-25		15.982	25mm				41.5			
CLM-20-CLC-20	20mm	19.995/	20mm	22	45	10	39.5	4	4.1	13
CLM-20-CLC-25		19.982	25mm				44.5			
CLM-25-CLC-20	25mm	24.995/	20mm	26	50	10	44	4	95	31
CLM-25-CLC-25		24.982	25mm				49			

* Spare Parts Kit includes screw, center ball, locking balls, and O-ring.

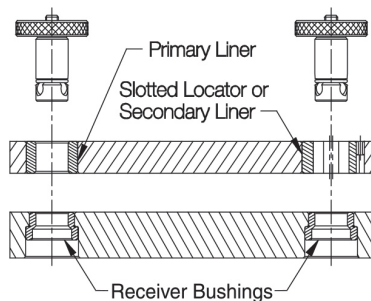

CARR LOCK® SYSTEM



Primary Liner Bushing



Secondary Liner Bushing



Slotted Locator Bushing

LINER BUSHINGS

Each top plate should have one Primary Liner, and one Secondary Liner or Slotted Locator Bushing. Primary Liners have a tight ID (+.0002/+.0007 tolerance) for precise reference in two axes. Secondary Liners have an extra .001" ID clearance (+.0012/+.0017 tolerance) to avoid binding. Slotted Locator Bushings provide better accuracy than Secondary Liners, but take a few extra steps to install. Slotted Locators have a tight ID tolerance in one direction and full relief in the perpendicular direction (available only in 16mm, 20mm, and 25mm diameters). Note: alternatively, two Primary Liners can be used for alignment if hole locations are held to ±.0002 inches.

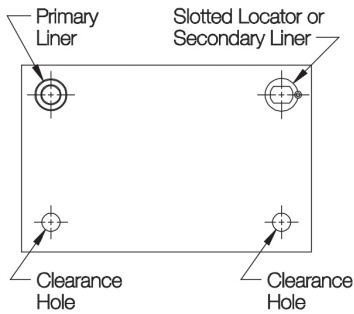

To mount top plates with more than two Carr Lock® Clamps, use clearance holes .015-.030 inches over nominal size for the additional holes, instead of liner bushings, to avoid redundant location. (Still use four Receiver Bushings in the subplate.)

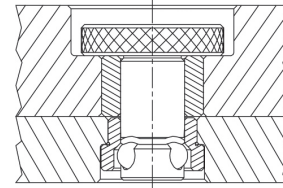

Extra-thick top plates can be counterbored to achieve proper clamping thickness (hold thickness to ±.005). Special-length Carr Lock® Clamps are also available, as specials.

PRIMARY LINER BUSHINGS (INCH)

PART NO.	ID	LENGTH	OD	HOLE IN PLATE		
CL-13-CLPL-0.50	13mm	.50	.7518	.7504		
CL-13-CLPL-0.75		.75	.7514	.7509		
CL-16-CLPL-0.50	16mm	.50	1.0018	1.0004		
CL-16-CLPL-0.75		.75	1.0014	1.0009		
CL-20-CLPL-0.75	20mm	.75	1.3772	1.3758		
CL-20-CLPL-1.00		1.00	1.3768	1.3763		
CL-25-CLPL-0.75	25mm	.75	1.3772	1.3758		
CL-25-CLPL-1.00		1.00	1.3768	1.3763		
CL-30-CLPL-0.75	30mm	.75	1.7523	1.7509		
CL-30-CLPL-1.00		1.00	1.7519	1.7514		
CL-35-CLPL-0.75	35mm	.75	1.7523	1.7509		
CL-35-CLPL-1.00		1.00				
CL-35-CLPL-1.50		1.50			1.7519	1.7514
CL-35-CLPL-2.00		2.00				
CL-50-CLPL-1.00	50mm	1.00	2.5025	2.5007		
CL-50-CLPL-1.50		1.50			2.5021	2.5012
CL-50-CLPL-2.00		2.00				

(METRIC)

CLM-13-CLPL-13	13mm	.512	19mm	.7487
CLM-13-CLPL-20		.787		.7491
CLM-16-CLPL-20	16mm	.787	25mm	.9849
CLM-16-CLPL-25		.984		.9853
CLM-20-CLPL-20	20mm	.787	35mm	1.3787
CLM-20-CLPL-25		.984		1.3791
CLM-25-CLPL-20	25mm	.787	35mm	1.3787
CLM-25-CLPL-25		.984		1.3791

SECONDARY LINER BUSHINGS (INCH)

PART NO.	ID	LENGTH	OD	HOLE IN PLATE		
CL-13-CLSL-0.50	13mm	.50	.7518	.7504		
CL-13-CLSL-0.75		.75	.7514	.7509		
CL-16-CLSL-0.50	16mm	.50	1.0018	1.0004		
CL-16-CLSL-0.75		.75	1.0014	1.0009		
CL-20-CLSL-0.75	20mm	.75	1.3772	1.3758		
CL-20-CLSL-1.00		1.00	1.3768	1.3763		
CL-25-CLSL-0.75	25mm	.75	1.3772	1.3758		
CL-25-CLSL-1.00		1.00	1.3768	1.3763		
CL-30-CLSL-0.75	30mm	.75	1.7523	1.7509		
CL-30-CLSL-1.00		1.00	1.7519	1.7514		
CL-35-CLSL-0.75	35mm	.75	1.7523	1.7509		
CL-35-CLSL-1.00		1.00			1.7519	1.7514
CL-35-CLSL-1.50		1.50				
CL-35-CLSL-2.00		2.00				
CL-50-CLSL-1.00	50mm	1.00	2.5025	2.5007		
CL-50-CLSL-1.50		1.50			2.5021	2.5012
CL-50-CLSL-2.00		2.00				

(METRIC)

CLM-13-CLSL-13	13mm	.512	19mm	.7487
CLM-13-CLSL-20		.787		.7491
CLM-16-CLSL-20	16mm	.787	25mm	.9849
CLM-16-CLSL-25		.984		.9853
CLM-20-CLSL-20	20mm	.787	35mm	1.3787
CLM-20-CLSL-25		.984		1.3791
CLM-25-CLSL-20	25mm	.787	35mm	1.3787
CLM-25-CLSL-25		.984		1.3791

SLOTTED LOCATOR BUSHINGS (INCH)

PART NO.	ID	LENGTH	OD	HOLE IN PLATE
—	13mm	—	—	—
CLM-16-SLLB	16mm	.472	1.1815 1.1812	1.1806 1.1809
CLM-20-SLLB	20mm	.748	1.4177 1.4174	1.4168 1.4171
CLM-25-SLLB	25mm	.748	1.5752 1.5749	1.5743 1.5746
—	30mm	—	—	—
—	35mm	—	—	—
—	50mm	—	—	—

(METRIC)

—	13mm	—	—	—
CLM-16-SLLB	16mm	.472	30mm	1.1806 1.1809
CLM-20-SLLB	20mm	.748	36mm	1.4168 1.4171
CLM-25-SLLB	25mm	.748	40mm	1.5743 1.5746

CARR LOCK® SYSTEM



**Face-Mount
Receiver Bushing**



**Back-Mount
Receiver Bushing**

RECEIVER BUSHINGS

Carr Lock® Clamps must be used in conjunction with one of these Receiver Bushings. Face-Mount Receiver Bushings can be bolted into a slip-fit bored hole from above, with three Socket-Head Cap Screws (furnished). Back-Mount Receiver Bushings are more compact, but take more effort to install. Back-mount bushings are installed in the subplate from below, with a slight press fit (measure actual bushing before boring hole to provide .0005 maximum press fit, to avoid I.D. distortion). With either bushing type, the installation holes must be jig bored for accurate size and location. Installed bushings will be approximately .012" below the subplate surface.

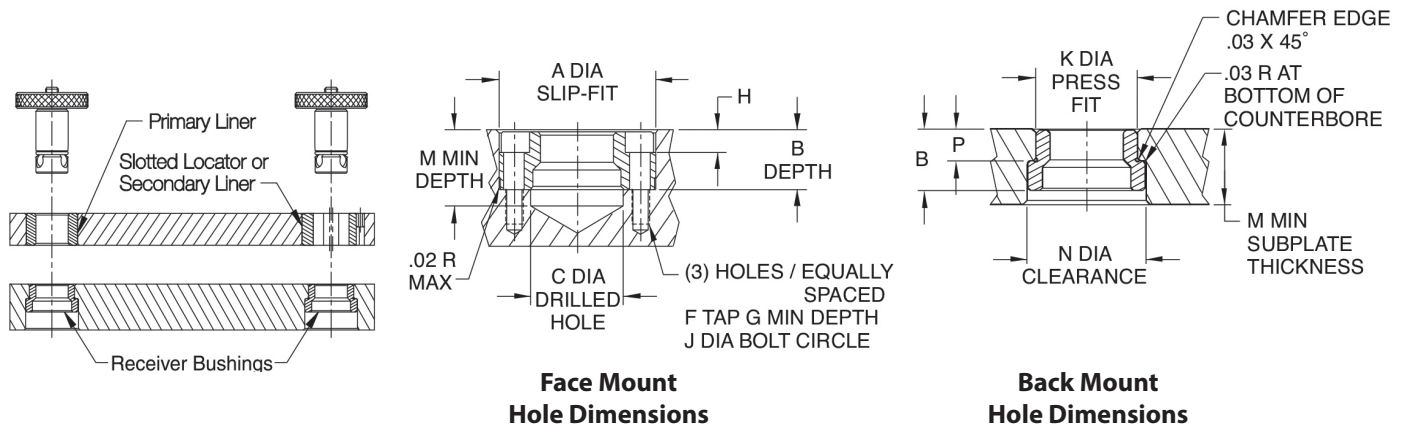

FACE-MOUNT RECEIVER BUSHINGS (INCH)

PART NO.	ID	A DIA		B		C	F	G	H	J DIA	M
		BUSHING	HOLE	BUSHING	HOLE						
CL-13-CLFR	13mm	1.3750	1.3750	.455	.469	.688	#8-32	.31	.180	.984	.75
		1.3746	1.3755								
CL-16-CLFR	16mm	1.4370	1.4370	.455	.469	.812	#8-32	.31	.193	1.125	.75
		1.4366	1.4375								
CL-20-CLFR	20mm	1.6873	1.6873	.623	.637	.812	#10-32	.38	.273	1.362	.83
		1.6869	1.6878								
CL-25-CLFR	25mm	2.0623	2.0623	.785	.799	1.000	1/4-28	.50	.316	1.644	1.00
		2.0619	2.0628								
CL-30-CLFR	30mm	2.2654	2.2654	.857	.871	1.188	1/4-28	.75	.316	1.876	1.23
		2.2650	2.2659								
CL-35-CLFR	35mm	2.6873	2.6873	.890	.904	1.562	5/16-24	.88	.375	2.178	1.28
		2.6869	2.6878								
CL-50-CLFR	50mm	3.4998	3.4998	1.225	1.239	2.156	3/8-24	1.00	.475	2.916	1.80
		3.4994	3.5003								

(METRIC)

CLM-13-CLFR	13mm	1.3776	1.3780	.455	.468	.531	M4	.39	.177	.984	.78
		1.3772	1.3783								
CLM-16-CLFR	16mm	1.4563	1.4567	.455	.468	.650	M4	.39	.177	1.142	.78
		1.4559	1.4570								
CLM-20-CLFR	20mm	1.7713	1.7717	.623	.637	.807	M5	.47	.236	1.378	.78
		1.7709	1.7720								
CLM-25-CLFR	25mm	2.1650	2.1654	.785	.799	1.004	M6	.59	.276	1.654	.98
		2.1646	2.1657								

BACK-MOUNT RECEIVER BUSHINGS (INCH)

PART NO.	ID	B	K DIA		M	N DIA		P
			BUSHING	HOLE		BUSHING	HOLE	
CL-13-CLBR	13mm	.475	.7870	ACTUAL BUSHING K DIA	.75	.995	.277	
			.7866			1.005	.275	
CL-16-CLBR	16mm	.475	.8760	.75	1.125	1.150	.285	
			.8756			1.160	.283	
CL-20-CLBR	20mm	.673	1.0950	.83	1.250	1.275	.345	
			1.0946			1.285	.343	
CL-25-CLBR	25mm	.826	1.3763	1.00	1.562	1.588	.416	
			1.3759			1.598	.414	
CL-30-CLBR	30mm	.857	1.6264	1.23	1.875	1.901	.432	
			1.6260			1.911	.430	
CL-35-CLBR	35mm	.990	1.8764	1.28	2.125	2.150	.493	
			1.8760			2.160	.491	
CL-50-CLBR	50mm	1.225	2.6269	1.80	2.937	2.963	.621	
			2.6265			2.973	.619	

(METRIC)

CLM-13-CLBR	13mm	.476	.7890	ACTUAL BUSHING K DIA	.78	.984	1.019	.273
			.7886			1.029	.271	
CLM-16-CLBR	16mm	.476	.8677	.78	1.125	1.137	.286	
			.8673			1.147	.284	
CLM-20-CLBR	20mm	.673	1.1039	.78	1.268	1.294	.345	
			1.1035			1.304	.343	
CLM-25-CLBR	25mm	.826	1.3795	.98	1.583	1.609	.416	
			1.3791			1.619	.414	

CARR LOCK® SYSTEM

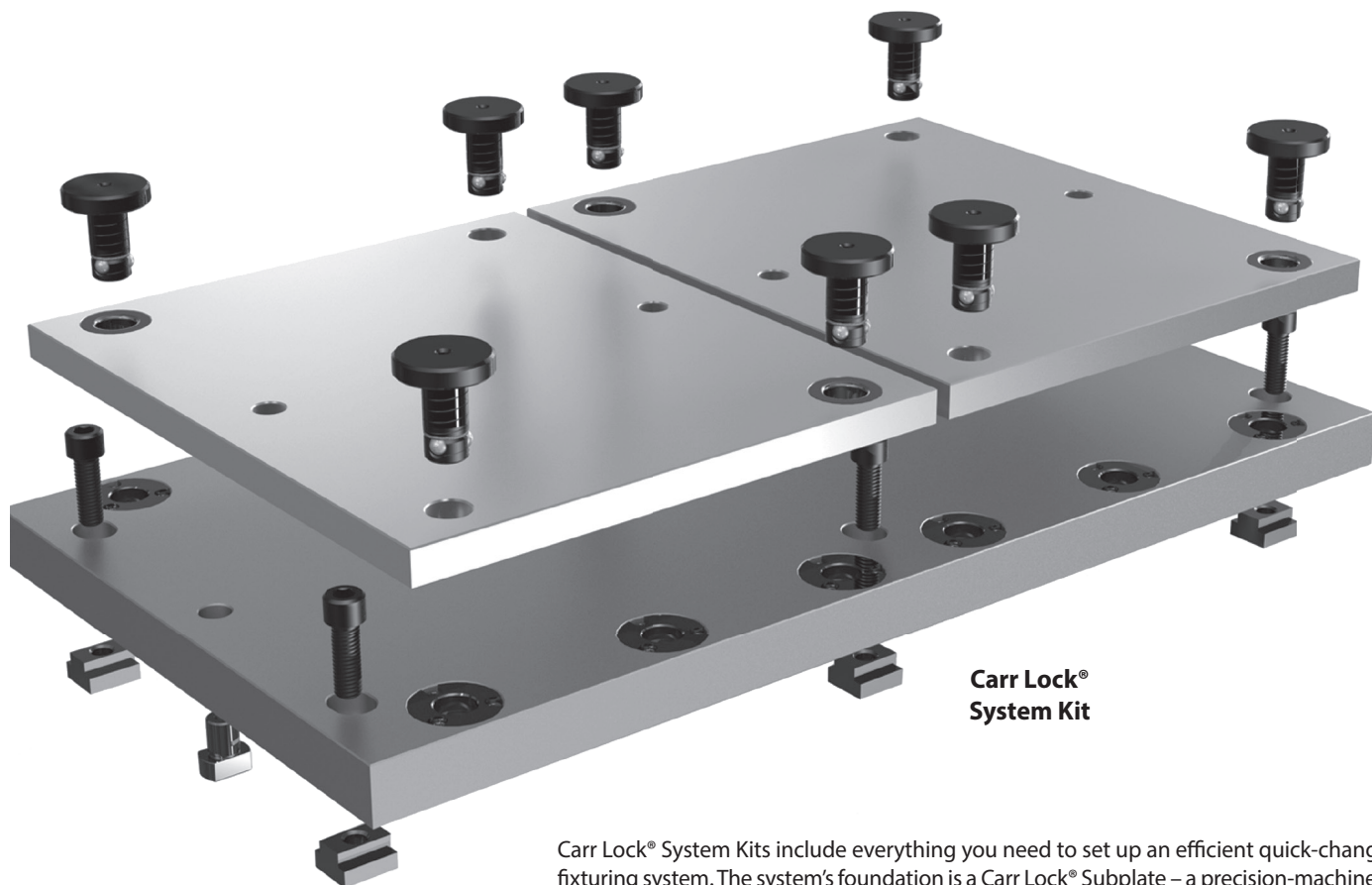

**Carr Lock®
System Kit**

Carr Lock® System Kits include everything you need to set up an efficient quick-change fixturing system. The system's foundation is a Carr Lock® Subplate – a precision-machined steel plate with Carr Lock® Receiver Bushings installed in a standard pattern. Carr Lock® System Kits also include one or more Carr Lock® Fixture Plates, plus all required Carr Lock® Clamps and subplate-mounting components.

The Carr Lock® System is extremely accurate. All Receiver-Bushing installation holes are located ± 0.0002 " from their primary reference hole. Clamping repeatability is ± 0.0005 ", while bushing concentricity is 0.0002 " TIR. The resulting x/y-axis repeatability of a mounted fixture plate is ± 0.0028 " considering all tolerance accumulation. Made in USA.

CARR LOCK® SYSTEM KITS

PART NO. CARR LOCK® SYSTEM KIT	FOR MACHINE	KIT INCLUDES CARR LOCK® SUBPLATE		KIT INCLUDES CARR LOCK® FIXTURE PLATES		KIT INCLUDES CARR LOCK® CLAMPS	KIT INCLUDES T NUTS AND SOCKET-HEAD CAP SCREWS	KIT INCLUDES FIXTURE KEYS
CL-1214-00-CLSK	HAAS® Mini Mill	12 x 14	CL-1214-00-CLSP	12 x 14	(1) CL-1214-00-CLFP	(4) CL-20-CLC-0.75	4	2
CL-1426-00-CLSK	HAAS® VF-1	14 x 26	CL-1426-00-CLSP	12 x 14	(2) CL-1214-00-CLFP	(8) CL-20-CLC-0.75	6	2
CL-1436-00-CLSK	HAAS® VF-2	14 x 36	CL-1436-01-CLSP	14 x 14	(2) CL-1414-00-CLFP	(8) CL-20-CLC-0.75	8	2
CL-1436-01-CLSK				Jigsaw	(3) CL-1016-01-CLFP	(9) CL-20-CLC-0.75		
CL-400400-00-CLSK	Various	400 x 400mm	CL-400400-00-CLSP	400 x 400mm	(1) CL-400400-00-CLFP	(4) CL-20-CLC-0.75	6	2
CL-1626-00-CLSK	HAAS® VF-1YT	16 x 26	CL-1626-00-CLSP	12 x 14	(2) CL-1214-00-CLFP	(8) CL-20-CLC-0.75	6	2
CL-1626-01-CLSK				Jigsaw	(2) CL-1016-01-CLFP	(6) CL-20-CLC-0.75		
CL-1636-00-CLSK	HAAS® VF-2YT	16 x 36	CL-1636-01-CLSP	14 x 14	(2) CL-1414-00-CLFP	(8) CL-20-CLC-0.75	8	2
CL-1636-01-CLSK				Jigsaw	(3) CL-1016-01-CLFP	(9) CL-20-CLC-0.75		
CL-5001000-00-CLSK	Various	500 x 1000mm	CL-5001000-01-CLSP	14 x 14	(2) CL-1414-00-CLFP	(8) CL-20-CLC-0.75	8	2
CL-5001000-01-CLSK				400 x 400mm	(2) CL-400400-00-CLFP	(8) CL-20-CLC-0.75		
CL-5001000-02-CLSK				500 x 500mm	(2) CL-500500-00-CLFP	(8) CL-25-CLC-1.00		
CL-5001000-03-CLSK				Jigsaw	(4) CL-1016-01-CLFP	(12) CL-20-CLC-0.75		

HAAS® is a registered trademark of HAAS® Automation, Inc.

CARR LOCK® SYSTEM

SUBPLATE: CARBON STEEL

RECEIVER BUSHINGS: 4340 STEEL, HEAT TREATED RC 50-54, BLACK OXIDE FINISH

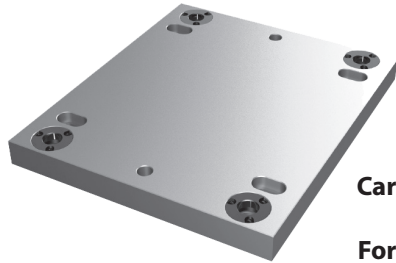

**Carr Lock® Subplate
12 x 14
For HAAS® Mini Mill**

Carr Lock® Subplates are precision-machined steel plates with Carr Lock® Receiver Bushings installed in a standard pattern. These subplates serve as the foundation of an efficient quick-change fixturing system. The 12 x 14 subplate shown here has (4) 20mm Face-Mount Receiver Bushings for mounting Fixture Plates.

Subplates should generally be large enough to cover most of the machine table, for maximum fixture flexibility, but should never extend beyond the machine table. For maximum quick-change benefits, subplates are usually left permanently on the machine table while only the mounted fixtures or vises are exchanged.

The Carr Lock® System is extremely accurate. All Receiver-Bushing installation holes are located $\pm .0002$ " from their primary reference hole. Clamping repeatability is $\pm .0005$ ", while bushing concentricity is $.0002$ " TIR. The resulting x/y-axis repeatability of a mounted fixture plate is $\pm .0028$ " considering all tolerance accumulation. Made in USA.

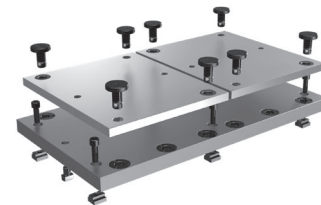
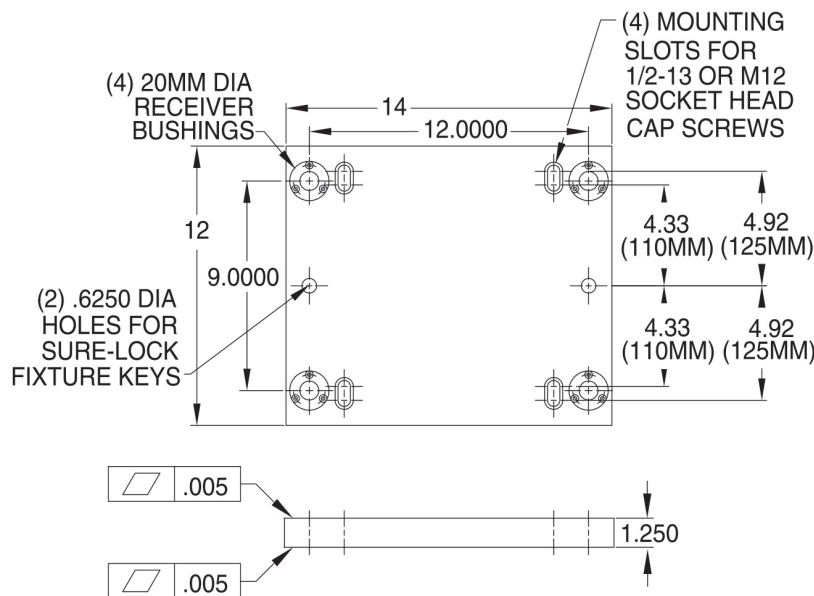

Carr Lock® System Kits

System Kits include everything you need to set up an efficient quick-change fixturing system. Kits include a Carr Lock® subplate, one or more Carr Lock® Fixture Plates, plus all required Carr Lock® Clamps and subplate-mounting components (Sure-Lock™ Fixture Keys, T Nuts, and Socket-Head Cap Screws).

CARR LOCK® SUBPLATE

PART NO.	FOR MACHINE	SUBPLATE SIZE	SUBPLATE THICKNESS	ACCEPTS CARR LOCK® FIXTURE PLATES	REQUIRES CARR LOCK® CLAMPS
CL-1214-00-CLSP	HAAS® MINI MILL	12 X 14	(4) CL-20-CLC-0.75	(1) CL-1214-00-CLFP	(4) CL-20-CLC-0.75

CARR LOCK® SYSTEM KIT

PART NO.	SYSTEM KIT INCLUDES					
	CARR LOCK® SUBPLATE 14 x 36	CARR LOCK® FIXTURE PLATE 14 x 14	CARR LOCK® CLAMPS 20mm	T NUTS 5/8	SOCKET-HEAD CAP SCREWS 1/2-13	SURE-LOCK™ FIXTURE KEYS 5/8
CL-1214-00-CLSK	(1) CL-1214-00-CLSP	(1) CL-1214-00-CLFP	(4) CL-20-CLC-0.75	(4) CL-2-TN	(4) CL-1/2-13X1.50-SHCS	(2) CL-6250-SLFK

CARR LOCK® SYSTEM

SUBPLATE: CARBON STEEL

RECEIVER BUSHINGS: 4340 STEEL, HEAT TREATED RC 50-54, BLACK OXIDE FINISH



**Carr Lock® Subplate
14 x 26
For HAAS® VF-1**

Carr Lock® Subplates are precision-machined steel plates with Carr Lock® Receiver Bushings installed in a standard pattern. These subplates serve as the foundation of an efficient quick-change fixturing system. The 14 x 26 subplate shown here has (12) 20mm Face-Mount Receiver Bushings to allow mounting a variety of fixture plates.

Subplates should generally be large enough to cover most of the machine table, for maximum fixture flexibility, but should never extend beyond the machine table. For maximum quick-change benefits, subplates are usually left permanently on the machine table while only the mounted fixtures or vises are exchanged.

The Carr Lock® System is extremely accurate. All Receiver-Bushing installation holes are located $\pm .0002$ " from their primary reference hole. Clamping repeatability is $\pm .0005$ ", while bushing concentricity is $.0002$ " TIR. The resulting x/y-axis repeatability of a mounted fixture plate is $\pm .0028$ " considering all tolerance accumulation. Made in USA.

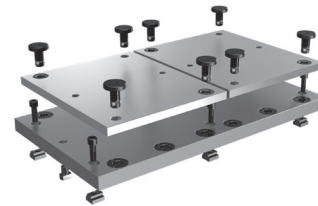
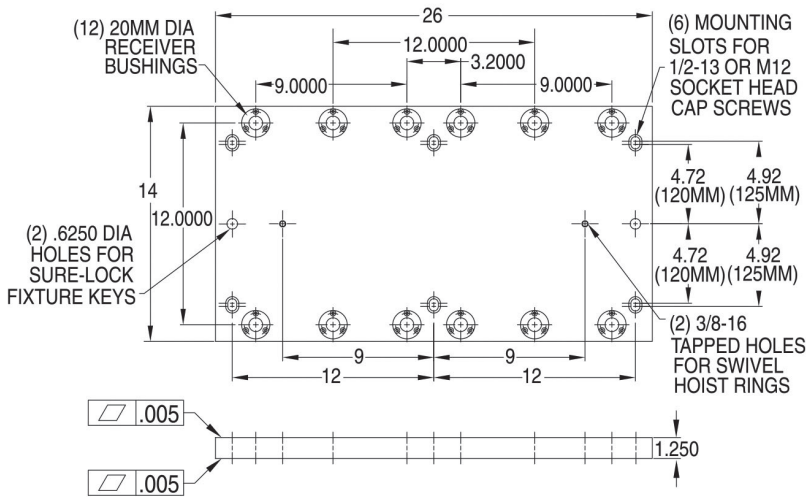

Carr Lock® System Kits

System Kits include everything you need to set up an efficient quick-change fixturing system. Kits include a Carr Lock® Subplate, one or more Carr Lock® Fixture Plates, plus all required Carr Lock® Clamps and subplate-mounting components (Sure-Lock™ Fixture Keys, T Nuts, and Socket-Head Cap Screws).

CARR LOCK® SUBPLATE

PART NO.	FOR MACHINE	SUBPLATE SIZE	SUBPLATE THICKNESS	ACCEPTS CARR LOCK® FIXTURE PLATES		REQUIRES CARR LOCK CLAMPS
				12 X 14	(2) CL-1214-00-CLFP	(8) CL-20-CLC-0.75
CL-1426-00-CLSP	HAAS® VF-1	14 X 26	1.250	12 X 14	(1) CL-1414-00-CLFP	(4) CL-20-CLC-0.75

CARR LOCK® SYSTEM KIT

PART NO.	SYSTEM KIT INCLUDES					
	CARR LOCK® SUBPLATE 14 x 36	CARR LOCK® FIXTURE PLATE 14 x 14	CARR LOCK® CLAMPS 20mm	T NUTS 5/8	SOCKET-HEAD CAP SCREWS 1/2-13	SURE-LOCK™ FIXTURE KEYS 5/8
CL-1426-00-CLSK	(1) CL-1426-00-CLSP	(2) CL-1214-00-CLFP	(8) CL-20-CLC-0.75	(6) CL-2-TN	(6) CL-1/2-13X1.50-SHCS	(2) CL-6250-SLFK

CARR LOCK® SYSTEM

SUBPLATE: CARBON STEEL

RECEIVER BUSHINGS: 4340 STEEL, HEAT TREATED RC 50-54, BLACK OXIDE FINISH

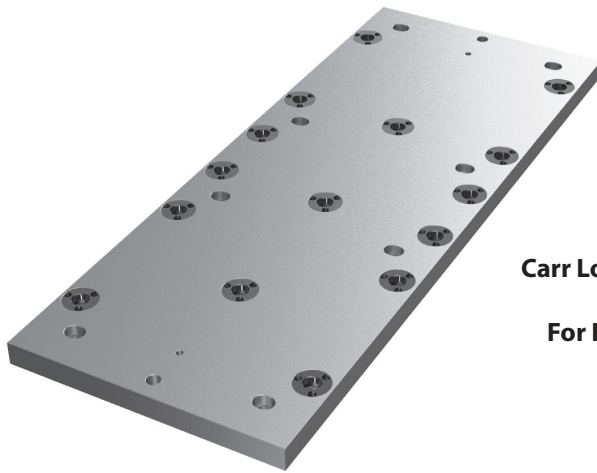

**Carr Lock® Subplate
14 x 36
For HAAS® VF-2**

Carr Lock® Subplates are precision-machined steel plates with Carr Lock® Receiver Bushings installed in a standard pattern. These subplates serve as the foundation of an efficient quick-change fixturing system. The 14 x 36 subplate shown here has (15) 20mm Face-Mount Receiver Bushings to allow mounting a variety of Fixture Plates and vise plates.

Subplates should generally be large enough to cover most of the machine table, for maximum fixture flexibility, but should never extend beyond the machine table. For maximum quick-change benefits, subplates are usually left permanently on the machine table while only the mounted fixtures or vises are exchanged.

The Carr Lock® System is extremely accurate. All Receiver-Bushing installation holes are located ± 0.0002 " from their primary reference hole. Clamping repeatability is ± 0.0005 ", while bushing concentricity is $.0002$ " TIR. The resulting x/y-axis repeatability of a mounted fixture plate is ± 0.0028 " considering all tolerance accumulation. Made in USA.

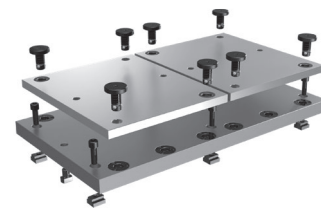
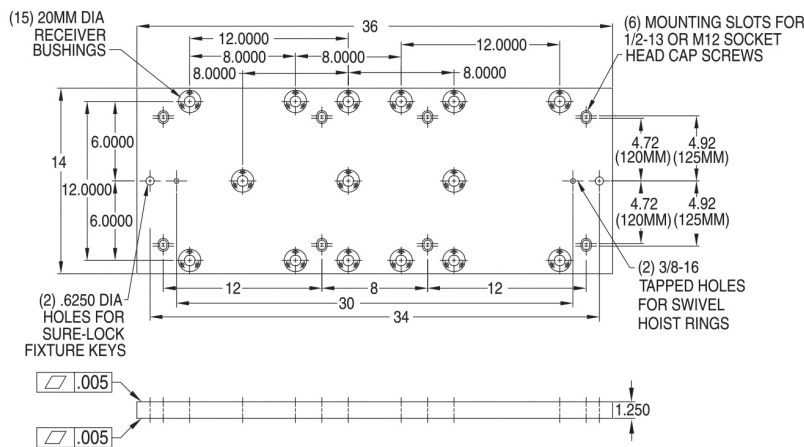

Carr Lock® System Kits

System Kits include everything you need to set up an efficient quick-change fixturing system. Kits include a Carr Lock® subplate, one or more Carr Lock® Fixture Plates, plus all required Carr Lock® Clamps and subplate-mounting components (Sure-Lock™ Fixture Keys, T Nuts, and Socket-Head Cap Screws).

CARR LOCK® SUBPLATE

PART NO.	FOR MACHINE	SUBPLATE SIZE	SUBPLATE THICKNESS	ACCEPTS CARR LOCK® FIXTURE PLATES		REQUIRES CARR LOCK® CLAMPS	
				14 X 14	(2) CL-1414-00-CLFP	(8) CL-20-CLC-0.75	Jigsaw
CL-1436-01-CLSP	HAAS® VF-2	14 X 36	1.250				

CARR LOCK® SYSTEM KITS

PART NO.	SYSTEM KIT INCLUDES					
	CARR LOCK® SUBPLATE 14 x 36	CARR LOCK® FIXTURE PLATE 14 x 14	CARR LOCK® CLAMPS 20mm	T NUTS 5/8	SOCKET-HEAD CAP SCREWS 1/2-13	SURE-LOCK™ FIXTURE KEYS 5/8
CL-1436-00-CLSK	(1) CL-1436-01-CLSP	(2) CL-1414-00-CLFP	(8) CL-20-CLC-0.75	(8) CL-2-TN	(8) CL-1/2-13X1.50-SHCS	(2) CL-6250-SLFK
CL-1436-01-CLSK	(1) CL-1436-01-CLSP	(3) CL-1016-01-CLFP	(9) CL-20-CLC-0.75	(8) CL-2-TN	(8) CL-1/2-13X1.50-SHCS	(2) CL-6250-SLFK

CARR LOCK® SYSTEM

SUBPLATE: CARBON STEEL

RECEIVER BUSHINGS: 4340 STEEL, HEAT TREATED RC 50-54, BLACK OXIDE FINISH



Version 00

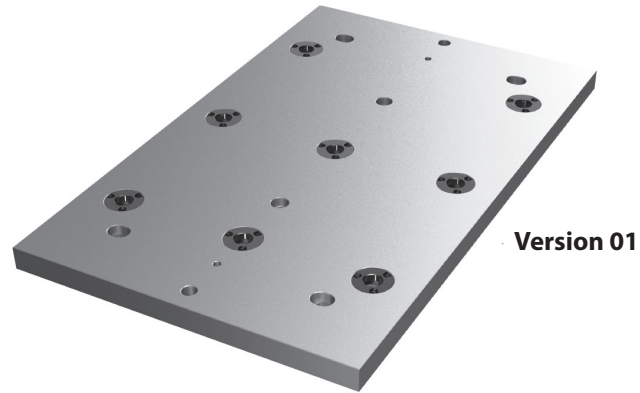

Version 01

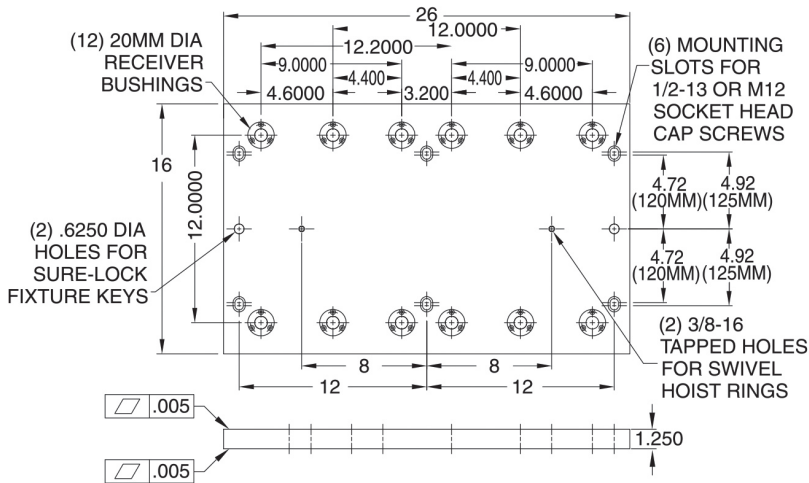

Carr Lock® Subplates 16 x 26 For HAAS® VF-1YT

Carr Lock® Subplates are precision-machined steel plates with Carr Lock Receiver Bushings installed in a standard pattern. These subplates serve as the foundation of an efficient quick-change fixturing system. The 16 x 26 subplates shown here have either (12) or (8) 20mm Face-Mount Receiver Bushings, depending on the version, to allow mounting a variety of Fixture Plates and vise plates.

Subplates should generally be large enough to cover most of the machine table, for maximum fixture flexibility, but should never extend beyond the machine table. For maximum quick-change benefits, subplates are usually left permanently on the machine table while only the mounted fixtures or vises are exchanged.

The Carr Lock® System is extremely accurate. All Receiver-Bushing installation holes are located +/- .0002" from their primary reference hole. Clamping repeatability is +/- .0005", while bushing concentricity is .0002" TIR. The resulting x/y-axis repeatability of a mounted fixture plate is +/- .0028" considering all tolerance accumulation. Made in USA.

Carr Lock® System Kits

System Kits include everything you need to set up an efficient quick-change fixturing system. Kits include a Carr Lock® subplate, one or more Carr Lock® Fixture Plates, plus all required Carr Lock® Clamps and subplate-mounting components (Sure-Lock™ Fixture Keys, T Nuts, and Socket-Head Cap Screws).



CARR LOCK® SUBPLATES

PART NO.	FOR MACHINE	SUBPLATE SIZE	SUBPLATE THICKNESS	ACCEPTS CARR LOCK® FIXTURE PLATES		REQUIRES CARR LOCK® CLAMPS
CL-1626-00-CLSP	HAAS® VF-2	16 X 26	1.250	12 X 14	(2) CL-1214-00-CLFP	(8) CL-20-CLC-0.75
				14 X 14	(1) CL-1414-00-CLFP	(4) CL-20-CLC-0.75
				400 x 400mm	(1) CL-400400-00-CLFP	(4) CL-20-CLC-0.75
CL-1626-01-CLSP				16 X 20	(1) CL-1620-00-CLFP	(4) CL-20-CLC-0.75
				Jigsaw	(2) CL-1016-01-CLFP	(6) CL-20-CLC-0.75

CARR LOCK® SYSTEM KITS

PART NO.	SYSTEM KIT INCLUDES					
	CARR LOCK® SUBPLATES 16 x 26	CARR LOCK® FIXTURE PLATES 12 x 14	CARR LOCK® CLAMPS 20mm	T NUTS 5/8	SOCKET-HEAD CAP SCREWS 1/2-13	SURE-LOCK™ FIXTURE KEYS 5/8
CL-1626-00-CLSK	(1) CL-1626-00-CLSP	(2) CL-1214-00-CLFP	(8) CL-20-CLC-0.75	(6) CL-2-TN	(6) CL-1/2-13X1.50-SHCS	(2) CL-6250-SLFK
CL-1626-01-CLSK	(1) CL-1626-01-CLSP	(2) CL-1016-01-CLFP	(6) CL-20-CLC-0.75	(6) CL-2-TN	(6) CL-1/2-13X1.50-SHCS	(2) CL-6250-SLFK

CARR LOCK® SYSTEM

SUBPLATE: CARBON STEEL

RECEIVER BUSHINGS: 4340 STEEL, HEAT TREATED RC 50-54, BLACK OXIDE FINISH

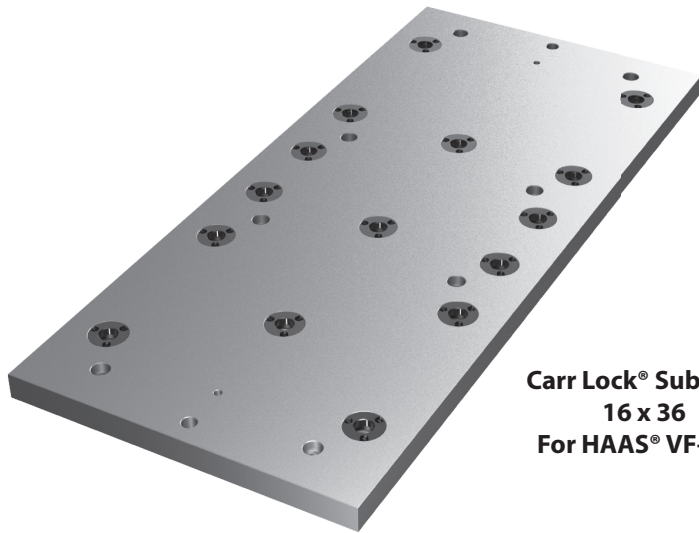

**Carr Lock® Subplate
16 x 36
For HAAS® VF-2YT**

Carr Lock® Subplates are precision-machined steel plates with Carr Lock® Receiver Bushings installed in a standard pattern. These subplates serve as the foundation of an efficient quick-change fixturing system. The 16 x 36 subplate shown here has (15) 20mm Face-Mount Receiver Bushings to allow mounting a variety of fixture plates and vise plates.

Subplates should generally be large enough to cover most of the machine table, for maximum fixture flexibility, but should never extend beyond the machine table. For maximum quick-change benefits, subplates are usually left permanently on the machine table while only the mounted fixtures or vises are exchanged.

The Carr Lock® System is extremely accurate. All Receiver-Bushing installation holes are located +/- .0002" from their primary reference hole. Clamping repeatability is +/- .0005", while bushing concentricity is .0002" TIR. The resulting x/y-axis repeatability of a mounted fixture plate is +/- .0028" considering all tolerance accumulation. Made in USA.

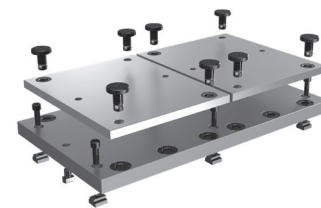
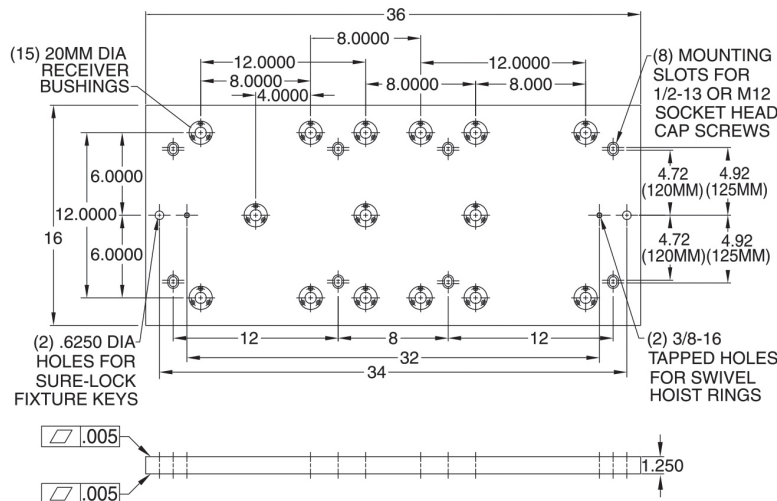

Carr Lock® System Kits

System Kits include everything you need to set up an efficient quick-change fixturing system. Kits include a Carr Lock® subplate, one or more Carr Lock® Fixture Plates, plus all required Carr Lock® Clamps and subplate-mounting components (Sure-Lock™ Fixture Keys, T Nuts, and Socket-Head Cap Screws).

9

CARR LOCK® SUBPLATES

PART NO.	FOR MACHINE	SUBPLATE SIZE	SUBPLATE THICKNESS	ACCEPTS CARR LOCK® FIXTURE PLATES		REQUIRES CARR LOCK® CLAMPS
CL-1636-01-CLSP	HAAS® VF-2YT	16 X 36	1.250	14 X 14	(2) CL-1414-00-CLFP	(8) CL-20-CLC-0.75
				400 x 400mm	(2) CL-400400-00-CLFP	(8) CL-20-CLC-0.75
				16 x 20	(1) CL-1620-00-CLFP	(4) CL-20-CLC-0.75
				Jigsaw	(3) CL-1016-01-CLFP	(9) CL-20-CLC-0.75

CARR LOCK® SYSTEM KITS

PART NO.	SYSTEM KIT INCLUDES					
	CARR LOCK® SUBPLATE 16 x 36	CARR LOCK® FIXTURE PLATE 14 x 14	CARR LOCK® CLAMPS 20mm	T NUTS 5/8	SOCKET-HEAD CAP SCREWS 1/2-13	SURE-LOCK™ FIXTURE KEYS 5/8
CL-1636-00-CLSK	(1) CL-1636-01-CLSP	(2) CL-1414-00-CLFP	(8) CL-20-CLC-0.75	(8) CL-2-TN	(8) CL-1/2-13X1.50-SHCS	(2) CL-6250-SLFK
CL-1636-01-CLSK	(1) CL-1636-01-CLSP	(3) CL-1016-01-CLFP	(9) CL-20-CLC-0.75	(8) CL-2-TN	(8) CL-1/2-13X1.50-SHCS	(2) CL-6250-SLFK

CARR LOCK® SYSTEM

SUBPLATE: CARBON STEEL

RECEIVER BUSHINGS: 4340 STEEL, HEAT TREATED RC 50-54, BLACK OXIDE FINISH

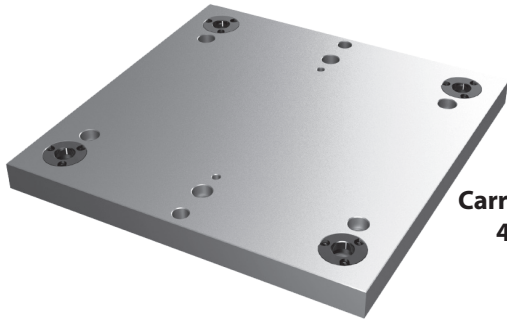

**Carr Lock® Subplate
400 x 400mm**

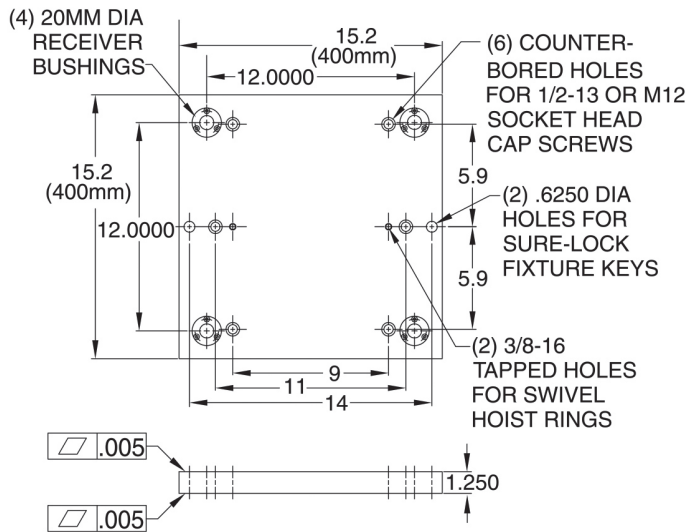

Carr Lock® Subplates are precision-machined steel plates with Carr Lock® Receiver Bushings installed in a standard pattern. These subplates serve as the foundation of an efficient quick-change fixturing system. The 400 x 400mm subplate shown here has (4) 20mm Face-Mount Receiver Bushings for mounting fixture plates.

Subplates should generally be large enough to cover most of the machine table, for maximum fixture flexibility, but should never extend beyond the machine table. For maximum quick-change benefits, subplates are usually left permanently on the machine table while only the mounted fixtures or vises are exchanged.

The Carr Lock® System is extremely accurate. All Receiver-Bushing installation holes are located $\pm .0002$ " from their primary reference hole. Clamping repeatability is $\pm .0005$ ", while bushing concentricity is $.0002$ " TIR. The resulting x/y-axis repeatability of a mounted fixture plate is $\pm .0028$ " considering all tolerance accumulation. Made in USA.

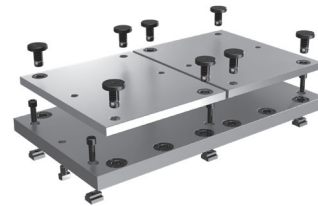

Carr Lock® System Kits

System Kits include everything you need to set up an efficient quick-change fixturing system. Kits include a Carr Lock® subplate, one or more Carr Lock® Fixture Plates, plus all required Carr Lock® Clamps and subplate-mounting components (Sure-Lock™ Fixture Keys, T Nuts, and Socket-Head Cap Screws).

CARR LOCK® SUBPLATE

PART NO.	FOR MACHINE	SUBPLATE SIZE	SUBPLATE THICKNESS	ACCEPTS CARR LOCK® FIXTURE PLATES		REQUIRES CARR LOCK® CLAMPS
				400 x 400mm	14 X 14	(4) CL-20-CLC-0.75
CL-400400-00-CLSP	Various	400 x 400mm	1.250	(1) CL-1214-00-CLFP	(1) CL-1414-00-CLFP	(4) CL-20-CLC-0.75

CARR LOCK® SYSTEM KIT

PART NO.	SYSTEM KIT INCLUDES					
	CARR LOCK® SUBPLATE 400 x 400mm	CARR LOCK® FIXTURE PLATE 400 x 400mm	CARR LOCK® CLAMPS 20mm	T NUTS 5/8	SOCKET-HEAD CAP SCREWS 1/2-13	SURE-LOCK™ FIXTURE KEYS 5/8
CL-400400-00-CLSK	(1) CL-400400-00-CLSP	(1) CL-400400-00-CLFP	(4) CL-20-CLC-0.75	(6) CL-2-TN	(6) CL-1/2-13X1.50-SHCS	(2) CL-6250-SLFK

CARR LOCK® SYSTEM

SUBPLATE: CARBON STEEL

RECEIVER BUSHINGS: 4340 STEEL, HEAT TREATED RC 50-54, BLACK OXIDE FINISH



**Carr Lock® Subplate
500 x 1000mm**

Carr Lock® Subplates are precision-machined steel plates with Carr Lock® Receiver Bushings installed in a standard pattern. These subplates serve as the foundation of an efficient quick-change fixturing system. The 500 x 1000mm subplate shown here has (18) 20mm and (8) 25mm Face-Mount Receiver Bushings to allow mounting a variety of fixture plates and vise plates.

Subplates should generally be large enough to cover most of the machine table, for maximum fixture flexibility, but should never extend beyond the machine table. For maximum quick-change benefits, subplates are usually left permanently on the machine table while only the mounted fixtures or vises are exchanged.

The Carr Lock® System is extremely accurate. All Receiver-Bushing installation holes are located +/- .0002" from their primary reference hole. Clamping repeatability is +/- .0005", while bushing concentricity is .0002" TIR. The resulting x/y-axis repeatability of a mounted fixture plate is +/- .0028" considering all tolerance accumulation. Made in USA.

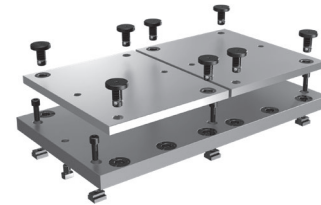
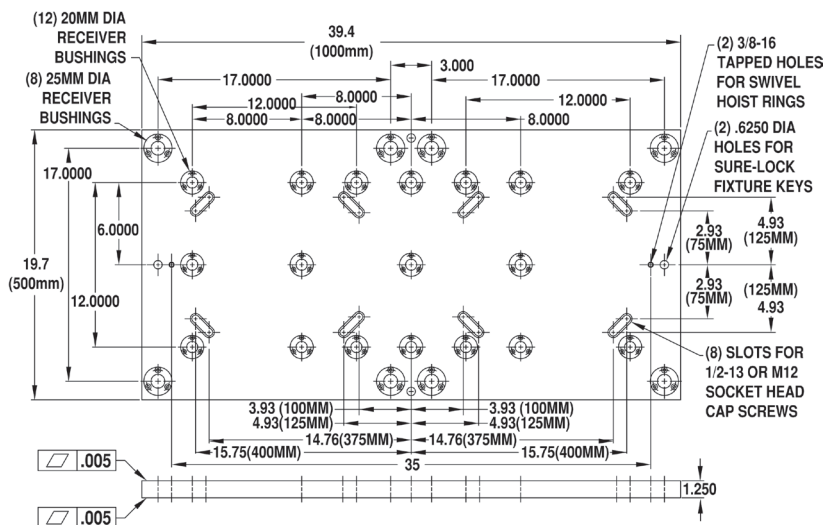

Carr Lock® System Kits

System Kits include everything you need to set up an efficient quick-change fixturing system. Kits include a Carr Lock® subplate, one or more Carr Lock® Fixture Plates, plus all required Carr Lock® Clamps and subplate-mounting components (Sure-Lock™ Fixture Keys, T Nuts, and Socket-Head Cap Screws).

CARR LOCK® SUBPLATE

PART NO.	FOR MACHINE	SUBPLATE SIZE	SUBPLATE THICKNESS	ACCEPTS CARR LOCK® FIXTURE PLATES	REQUIRES CARR LOCK® CLAMPS	
CL-5001000-02-CLSP	Various	500 x 1000mm	1.250	14 X 14	(2) CL-1414-00-CLFP	(8) CL-20-CLC-0.75
				400 x 400mm	(2) CL-400400-00-CLFP	(8) CL-20-CLC-0.75
				16 x 20	(1) CL-1620-00-CLFP	(4) CL-20-CLC-0.75
				500 x 500mm	(2) CL-500500-00-CLFP	(8) CL-25-CLC-1.00
				Jigsaw	(4) CL-1016-01-CLFP	(12) CL-20-CLC-0.75

CARR LOCK® SYSTEM KITS

PART NO.	SYSTEM KIT INCLUDES					
	CARR LOCK® SUBPLATES 14 x 26	CARR LOCK® FIXTURE PLATES 12 x 14	CARR LOCK® CLAMPS 20mm	T NUTS 5/8	SOCKET-HEAD CAP SCREWS 1/2-13	SURE-LOCK™ FIXTURE KEYS 5/8
CL-5001000-00-CLSK	(1) CL-5001000-02-CLSP	(2) CL-1414-00-CLFP	(8) CL-20-CLC-0.75	(8) CL-3-TN	(8) CL-1/2-13X1.50-SHCS	(2) CL-18-SLFK
CL-5001000-01-CLSK	(1) CL-5001000-02-CLSP	(2) CL-400400-00-CLFP	(8) CL-20-CLC-0.75	(8) CL-3-TN	(8) CL-1/2-13X1.50-SHCS	(2) CL-18-SLFK
CL-5001000-02-CLSK	(1) CL-5001000-02-CLSP	(2) CL-500500-00-CLFP	(8) CL-25-CLC-1.00	(8) CL-3-TN	(8) CL-1/2-13X1.50-SHCS	(2) CL-18-SLFK
CL-5001000-03-CLSK	(1) CL-5001000-02-CLSP	(4) CL-1016-01-CLFP	(12) CL-20-CLC-0.75	(8) CL-3-TN	(8) CL-1/2-13X1.50-SHCS	(2) CL-18-SLFK

CARR LOCK® SYSTEM

FIXTURE PLATE: MIC-6 PRECISION-MACHINED CAST ALUMINUM
 LINER BUSHINGS: 1144 STEEL, HEAT TREATED RC 58-64, BLACK OXIDE FINISH

Carr Lock® Fixture Plates

Carr Lock® Fixture Plates are precision-machined MIC-6 cast aluminum plates available in a wide range of standard sizes to use as a base for building quick-change fixtures. To fasten the Carr Lock® Fixture Plate to a subplate, begin by inserting a Carr Lock® Clamp into each of the four corner holes. Next, fully tighten the clamps one at a time – first the clamp in the primary liner bushing, then the clamp in the secondary liner bushing, then the clamps in the clearance holes. Made in USA.

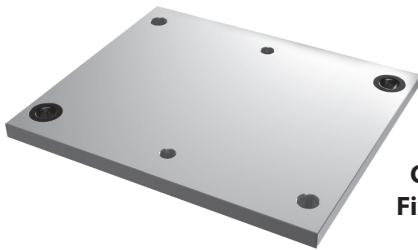
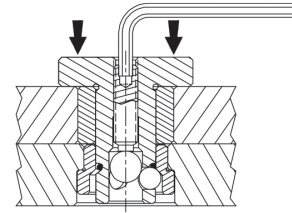

**Carr Lock®
 Fixture Plate
 12 x 14**

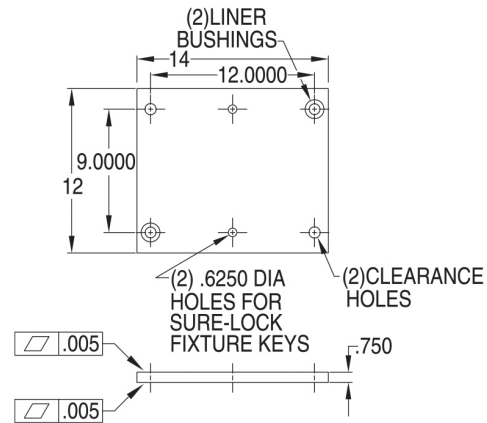

These 12 x 14 fixture plates have four 20mm mounting holes – a primary liner, a secondary liner, and two clearance holes. They also have two fixture-key holes for conventional mounting directly on a slotted machine table using Sure-Lock™ Fixture Keys.

CARR LOCK® FIXTURE PLATE — 12 X 14

PART NO.	PLATE SIZE	PLATE THICKNESS	REQUIRES CARR LOCK® CLAMPS	CARR LOCK® CLAMP SPACING
CL-1214-00-CLFP	12 X 14	.750	(4) CL-25-CLC-0.75	9 X 12

9

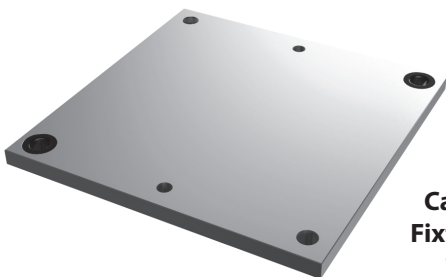

**Carr Lock®
 Fixture Plate
 14 x 14**

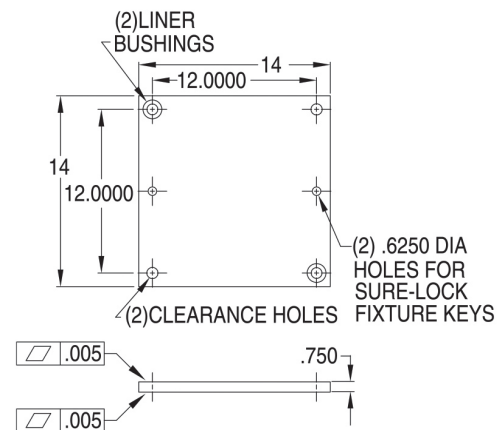

These 14 x 14 fixture plates have four 20mm mounting holes – a primary liner, a secondary liner, and two clearance holes. They also have two fixture-key holes for conventional mounting directly on a slotted machine table using Sure-Lock™ Fixture Keys.

CARR LOCK® FIXTURE PLATE — 14 X 14

PART NO.	PLATE SIZE	PLATE THICKNESS	REQUIRES CARR LOCK® CLAMPS	CARR LOCK® CLAMP SPACING
CL-1414-00-CLFP	14 X 14	.750	(3) CL-20-CLC-0.75	12 X 12

CARR LOCK® SYSTEM

FIXTURE PLATE: MIC-6 PRECISION-MACHINED CAST ALUMINUM
 LINER BUSHINGS: 1144 STEEL, HEAT TREATED RC 58-64, BLACK OXIDE FINISH



**Carr Lock®
 Fixture Plate
 400 x 400mm**

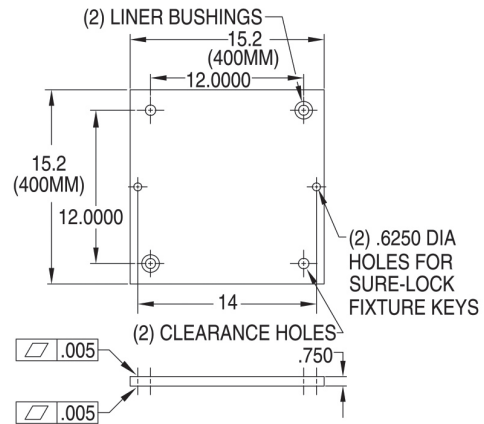

These 400 x 400mm fixture plates have four 20mm mounting holes – a primary liner, a secondary liner, and two clearance holes. They also have two fixture-key holes for conventional mounting directly on a slotted machine table using Sure-Lock™ Fixture Keys.

CARR LOCK® FIXTURE PLATE — 400 x 400mm

PART NO.	PLATE SIZE	PLATE THICKNESS	REQUIRES CARR LOCK® CLAMPS	CARR LOCK® CLAMP SPACING
CL-400400-00-CLFP	400 x 400	.750	(4) CL-20-CLC-0.75	12 x 12

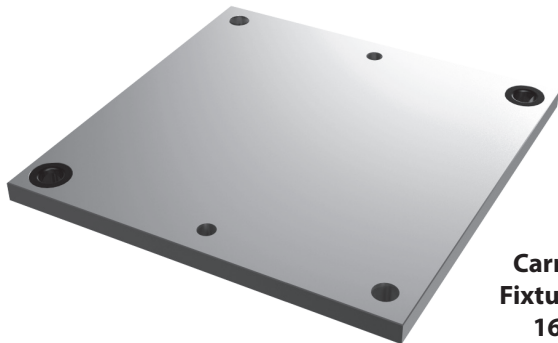

**Carr Lock®
 Fixture Plate
 16 x 20**

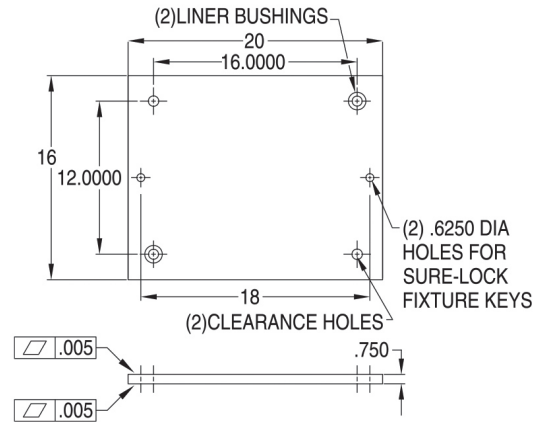

These 16 x 20 fixture plates have four 20mm mounting holes – a primary liner, a secondary liner, and two clearance holes. They also have two fixture-key holes for conventional mounting directly on a slotted machine table using Sure-Lock™ Fixture Keys.

CARR LOCK® FIXTURE PLATE — 16 x 20

PART NO.	PLATE SIZE	PLATE THICKNESS	REQUIRES CARR LOCK® CLAMPS	CARR LOCK® CLAMP SPACING
CL-1620-00-CLFP	16 x 20	.750	(4) CL-20-CLC-0.75	12 x 16

CARR LOCK® SYSTEM

FIXTURE PLATE: MIC-6 PRECISION-MACHINED CAST ALUMINUM
 LINER BUSHINGS: 1144 STEEL, HEAT TREATED RC 58-64, BLACK OXIDE FINISH

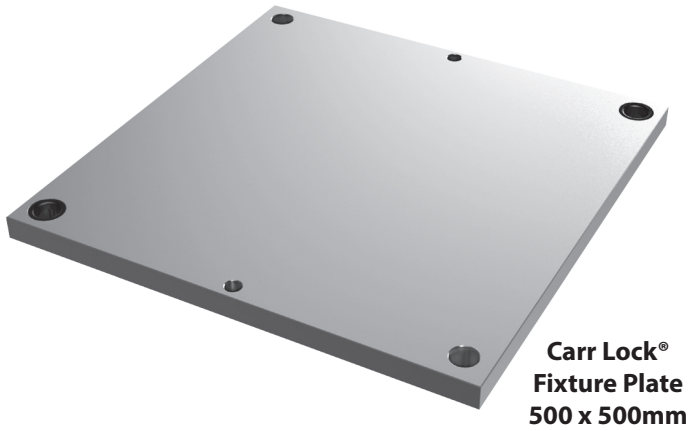

**Carr Lock®
 Fixture Plate
 500 x 500mm**

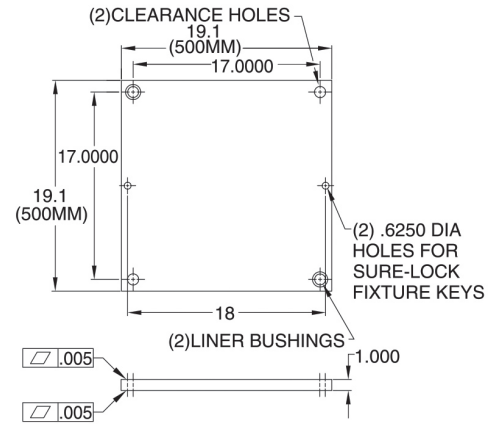

These 500 x 500mm fixture plates have four 25mm mounting holes – a primary liner, a secondary liner, and two clearance holes. They also have two fixture-key holes for conventional mounting directly on a slotted machine table using Sure-Lock™ Fixture Keys.

CARR LOCK® FIXTURE PLATE — 500 x 500mm

PART NO.	PLATE SIZE	PLATE THICKNESS	REQUIRES CARR LOCK® CLAMPS	CARR LOCK® CLAMP SPACING
CL-500500-00-CLFP	500x500	1.000"	(4) CL-25-CLC-1.000	17x17

9

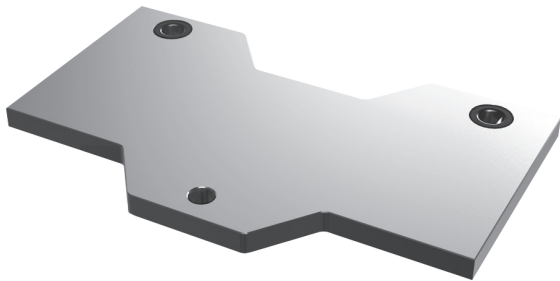

**Carr Lock®
 Jigsaw Vise Plate
 10 x 16**

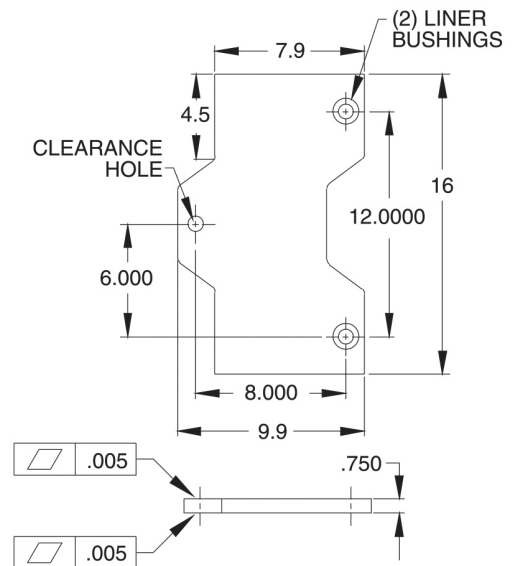

Jigsaw Vise Plates have an interlocking design to allow mounting vises and other narrow fixtures close together. These 10 x 16 plates have three 20mm mounting holes – a primary liner, a secondary liner, and a clearance hole.

CARR LOCK® JIGSAW VISE PLATE — 10 x 16

PART NO.	PLATE SIZE	PLATE THICKNESS	REQUIRES CARR LOCK® CLAMPS	CARR LOCK® CLAMP SPACING
CL-1016-01-CLFP	10 x 16	.750	(3) CL-20-CLC-0.75	8 x 12

CARR LOCK® SYSTEM

FIXTURE MACHINING KITS

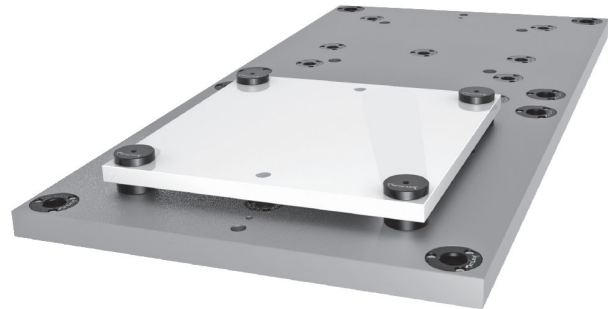

Carr Lock® Fixture Machining Kits are extremely useful for machining a fixture using its Carr Lock® mounting holes as an absolute reference. The kit consists of four extra-long Carr Lock® Clamps, used together with four precision-height spacers, providing ample clearance underneath the fixture plate to allow through-hole machining without damaging the subplate. The kit also includes an extra four spacers to use as additional supports under large plates, all in a handy carrying case. Made in USA.

FIXTURE MACHINING KITS

PART NO.	CARR LOCK® CLAMP DIAMETER	FOR FIXTURE-PLATE THICKNESS	SPACER HEIGHT	SPACER OD
CL-20-CLMK-0.75	20mm	.750	.500	1-3/4
CL-25-CLMK-0.75	25mm	.750	.750	2
CL-25-CLMK-1.00		1.000	.500	2



These handy Preset Torque Wrenches are designed to tighten Carr Lock® Clamps exactly to their maximum recommended torque, ensuring that maximum hold-down force is achieved without over-tightening. The wrench body shown here is used for the first three Carr Lock® Clamp sizes – 13mm, 16mm, and 20mm – each preset to the torque recommended for that size, and with the appropriate hex key. A slightly larger wrench body is used for the 25mm size. Torque accuracy is +/-10%.

9

PRESET TORQUE WRENCHES

PART NO.	FOR CARR LOCK® CLAMP DIA	PRESET TORQUE (FT-LBS)	HEX KEY SIZE	HANDLE LENGTH	HANDLE WIDTH
CL-13-CLTW	13mm	1.0	3/32	3.54	1.40
CL-16-CLTW	16mm	2.0	1/8		
CL-20-CLTW	20mm	3.0	1/8		
CL-25-CLTW	25mm	7.0	5/32	7.50	1.67



Protection plugs are extremely useful to keep chips and debris from entering unused receiver bushings in a subplate. These durable plastic plugs fit snugly in the receiver hole, yet can be easily removed.

PROTECTION PLUGS

PART NO.	FOR CARR LOCK® RECEIVER DIA.
CL-13-CLPP	13mm
CL-16-CLPP	16mm
CL-20-CLPP	20mm
CL-25-CLPP	25mm
CL-30-CLPP	30mm

HEADLESS CARR LOCK® CLAMP

CLAMP BODY: 4340 STEEL, HEAT TREATED, RC 40-45
 BALLS: 440C STAINLESS
 CLAMPING SCREW: CARBON STEEL, BLACK OXIDE
 O-RING: VITON



The Headless Carr Lock® System allows accurately locating and clamping at the same time, with just the turn of a hex wrench. Ideal for mounting quick-change tooling on a subplate while taking minimal real estate on the top of your fixture. The Headless Carr Lock® Clamp comes in two variants, primary (-1) and secondary (-2). The primary clamp is used to accurately locate your plate while the looser fit on the secondary clamp reduces binding. Made in USA, available in 13mm, 16mm, and 20mm Shank Diameters.

PART NO.	A SHANK DIA NOMINAL	A SHANK DIA ACTUAL	B	C	D THREAD	E HEX	MAX SCREW TORQUE (ft-lbs)
CL-13-HCLC-1	13mm	.5116/.5111	.38	.58	3/8-24	3/32	1
CL-16-HCLC-1	16mm	.6297/.6292	.50	.65	1/2-20	1/8	2
CL-20-HCLC-1	20mm	.7872/.7867	.75	.78	3/4-16	1/8	3

CL-13-HCLC-2	13mm	.4960/.4940	.38	.58	3/8-24	3/32	1
CL-16-HCLC-2	16mm	.6140/.6120	.50	.65	1/2-20	1/8	2
CL-20-HCLC-2	20mm	.7720/.7700	.75	.78	3/4-16	1/8	3

Application Examples:

Application 1:

- (1) Headless Carr Lock Clamp
- (1) Round Pin
- (1) Diamond Pin

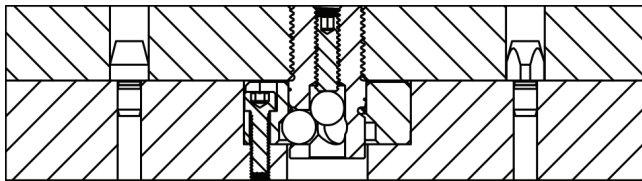

Application 2 description:

- (2) Headless Carr Lock Clamps

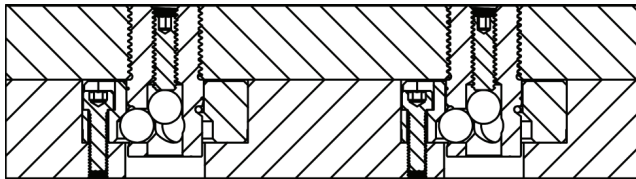

See the website for all available options.

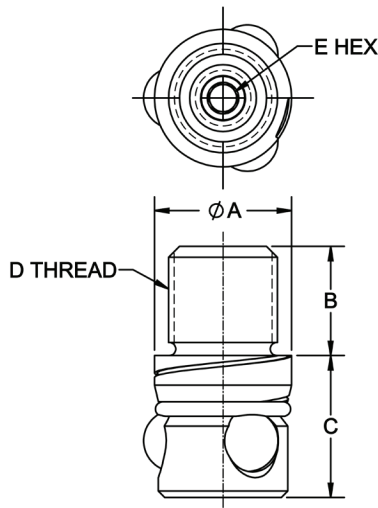

CL5® QUICK-CHANGE 5-AXIS WORKHOLDING

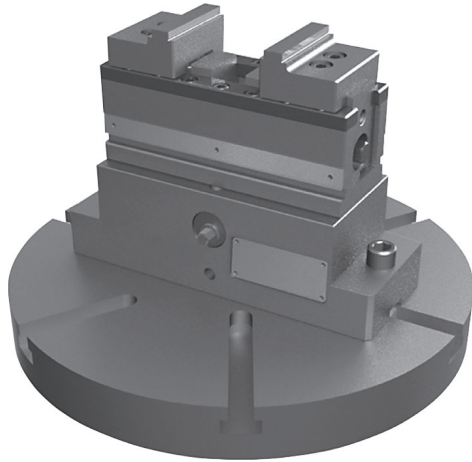

**Quintus Riser
with
5-Axis Vise**

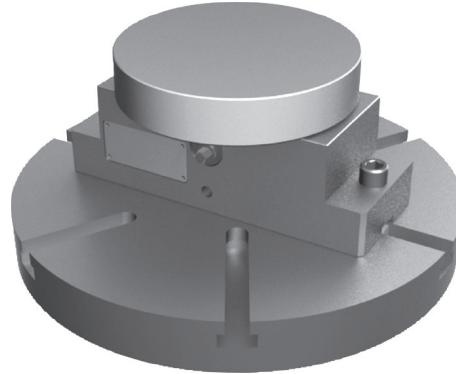

**Quintus Riser
with
Blank Fixture Plate**

Method 2 utilizes our Quintus Quick-Change Risers to achieve full quick-change fixturing benefits on rotary tables 250mm diameter and larger. A Quintus Quick-Change Riser provides additional height for spindle clearance, and can be quickly and accurately mounted directly on the rotary table at its center. **INFO+**: See pages 379-381 for Quintus fixture plates.

9

METHOD 2 QUINTUS MOUNTED ON ROTARY TABLE

BASE OPTIONS	BASE SIZE	WORKHOLDER OPTIONS	FITS TABLE DIAMETER																
			110mm	130mm	160mm	200mm	210mm	250mm	260mm	300mm	310mm	320mm	400mm	450mm	500mm	500mm	600mm	630mm	
Quintus Riser with 5-Axis Vise	Quintus 1	MC40, MC40Z, MC60, MC60Z, SCS80 Vises						✓	✓	✓	✓	✓	✓	✓	✓	✓	✓	✓	
	Quintus 2	MC100, MC100Z, SCS120 Vises								✓	✓	✓	✓	✓	✓	✓	✓	✓	
	Quintus 3	MC125Z Vise											✓	✓	✓	✓	✓	✓	
Quintus Riser with Blank Fixture Plate	Quintus 1 + 130mm	Custom						✓	✓	✓	✓	✓	✓	✓	✓	✓	✓	✓	
	Quintus 1 + 160mm						✓	✓	✓	✓	✓	✓	✓	✓	✓	✓	✓	✓	
	Quintus 1 + 100x250mm						✓	✓	✓	✓	✓	✓	✓	✓	✓	✓	✓	✓	✓
	Quintus 1 + 150x250mm						✓	✓	✓	✓	✓	✓	✓	✓	✓	✓	✓	✓	✓
	Quintus 2 + 250mm									✓	✓	✓	✓	✓	✓	✓	✓		

CL5® QUICK-CHANGE 5-AXIS WORKHOLDING

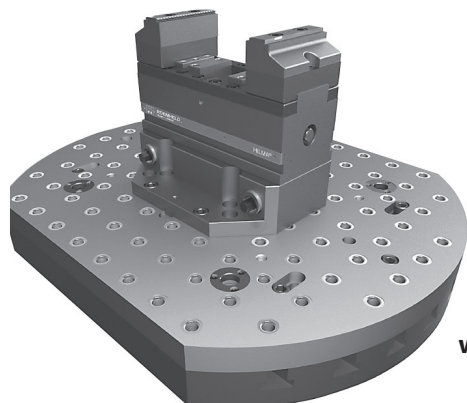

Subplate with Quintus Riser and 5-Axis Vise

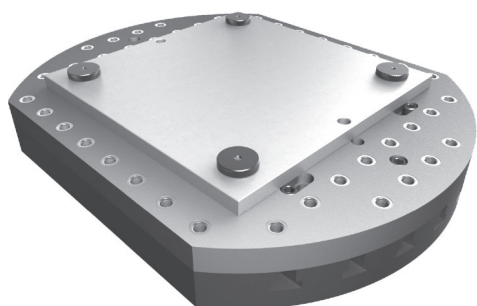

Subplate with Carr Lock Fixture Plate

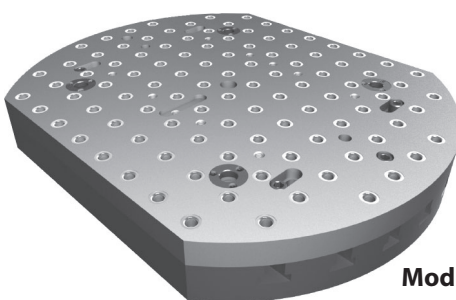

Subplate used as Modular Fixture Plate

Method 3 is appropriate for medium and large machine tables, achieving further quick-change benefits for the entire riser assembly. Using this method, the Quintus riser is mounted on a subplate to allow quick exchange of the riser with other fixturing. **INFO+**: See pages 381-382 for subplates.

9

METHOD 3 SUBPLATE MOUNTED ON ROTARY TABLE

BASE OPTIONS	BASE SIZE	WORKHOLDER OPTIONS	FITS TABLE DIAMETER																	
			110mm	130mm	160mm	200mm	210mm	250mm	260mm	300mm	310mm	320mm	400mm	450mm	500mm	500mm	600mm	630mm		
Subplate with Quintus Riser and 5-Axis Vise	250mm + Quintus 1	MC40, MC40Z, MC60, MC60Z, SCS80 Vises or Custom							✓	✓										
	310mm + Quintus 1	MC40, MC40Z, MC60, MC60Z, SCS80 Vises or Custom									✓	✓	✓	✓						
	310mm + Quintus 2	MC100, MC100Z, SCS120 Vises or Custom									✓	✓	✓	✓						
	630x500mm + Quintus 1	MC40, MC40Z, MC60, MC60Z, SCS80 Vises or Custom																✓	✓	
	630x500mm + Quintus 2	MC100, MC100Z, SCS120 Vises or Custom																	✓	✓
Subplate used as Modular Fixture Plate	630x500mm + Quintus 3	MC125Z Vise or Custom																	✓	✓
	250mm	Custom							✓	✓										
	310mm										✓	✓	✓	✓						
630x500mm																			✓	✓

CL5[®] QUICK-CHANGE 5-AXIS WORKHOLDING

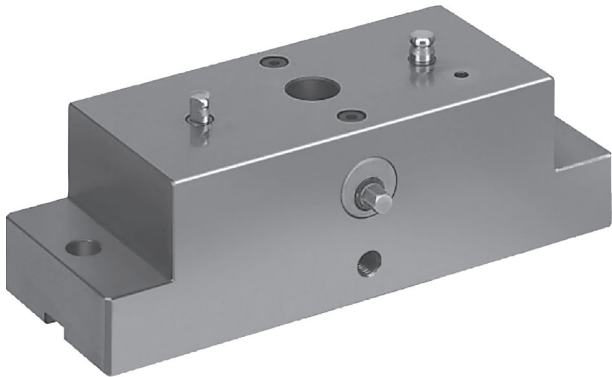

Quintus 1
Quick-Change Riser
 Pull-Down Force 2700 Lbs
 CLRH-9-6153-0101-VSA

Quintus Quick-Change Risers provide accurate location and secure clamping while also providing quick-change capability and elevating the workpiece for improved spindle access – all in one compact unit. The Quintus 1 riser shown here utilizes two locating pins, a round pin for zero-point centering and a diamond pin for single-axis centering, and a single pull-down bolt that provides 2700 lbs of pull-down force.

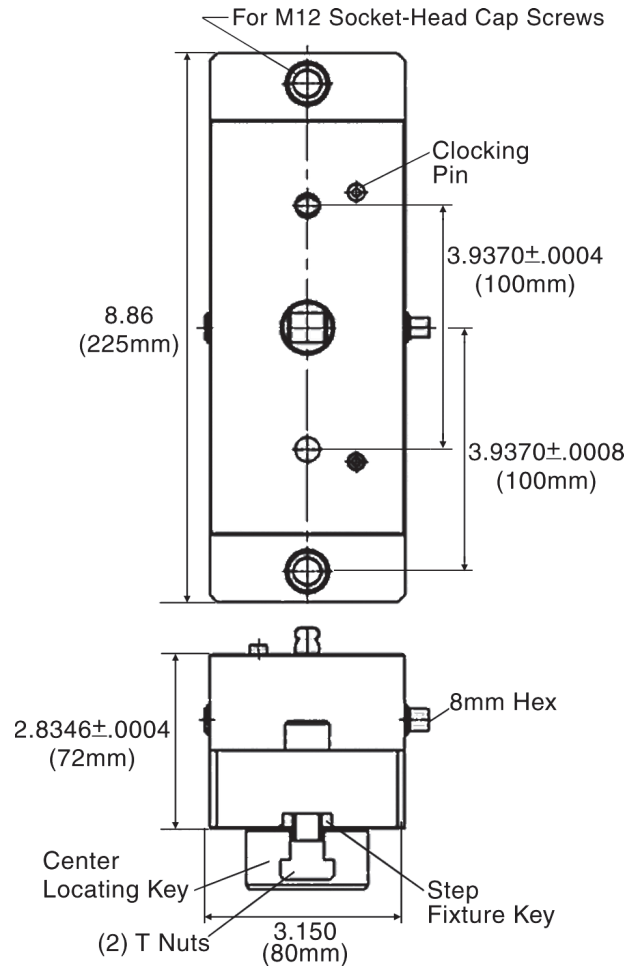
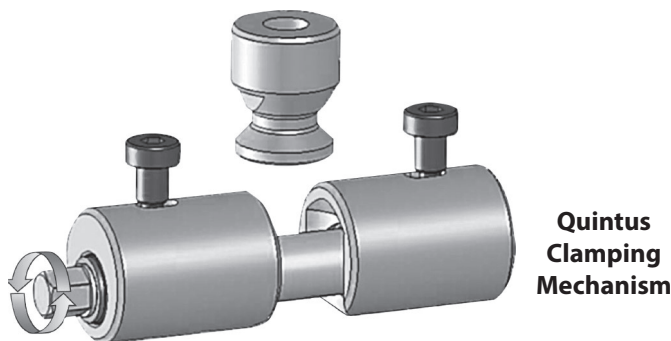
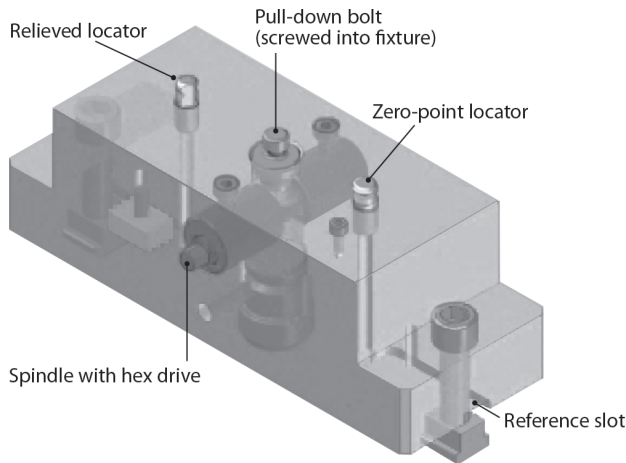

9

CL5® QUICK-CHANGE 5-AXIS WORKHOLDING

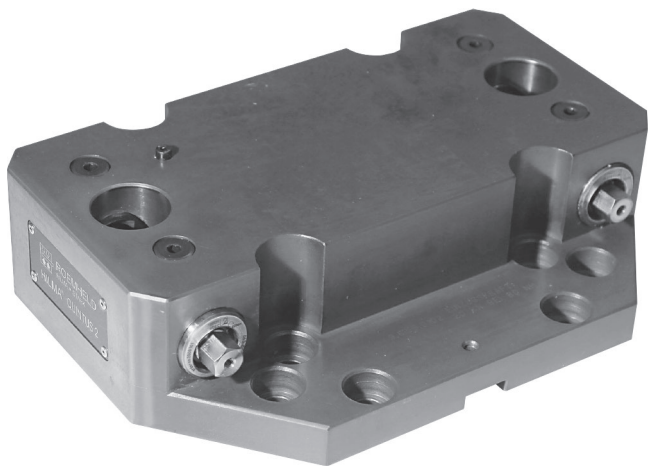

Quintus 2
Quick-Change Riser
 Pull-Down Force 4500 Lbs x 2
 CLRH-9-6155-0102-VSA

Quintus Quick-Change Risers provide accurate location and secure clamping while also providing quick-change capability and elevating the workpiece for improved spindle access – all in one compact unit. The Quintus 2 riser shown here utilizes two pull-down bolts – one with zero-point centering, the other with single-axis centering – providing 2 x 4500 lbs of pull-down force.

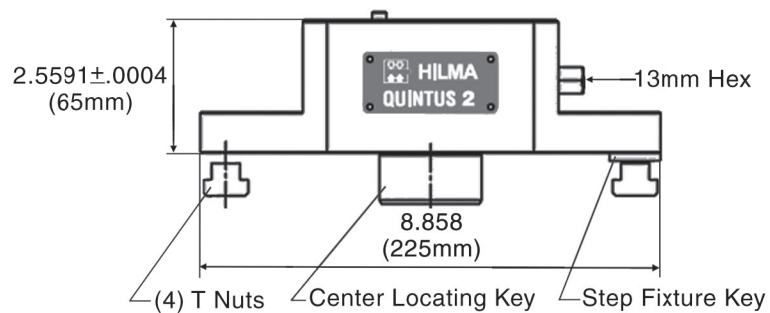
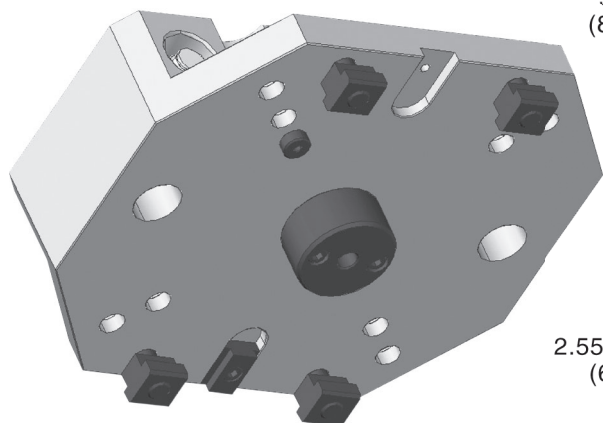
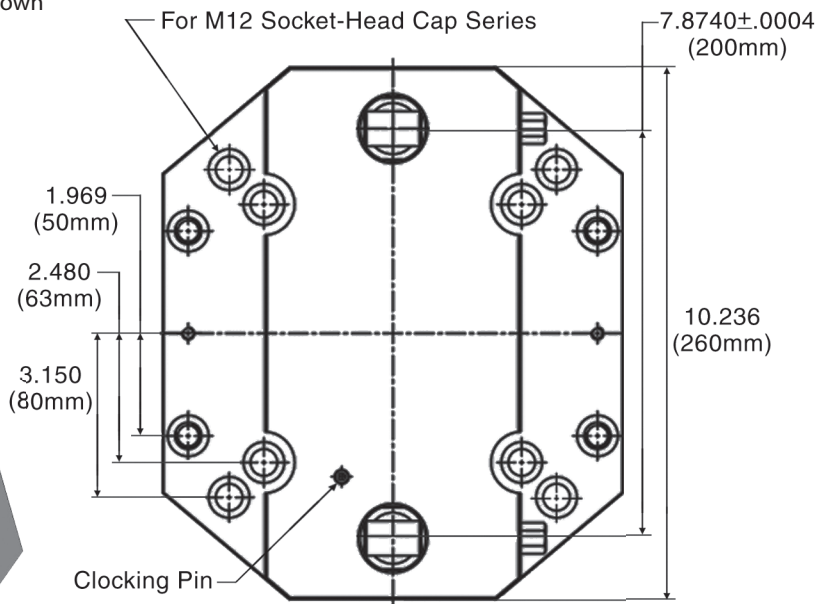

CL5[®] QUICK-CHANGE 5-AXIS WORKHOLDING

5-AXIS VISES FOR MOUNTING ON QUINTUS 1

MCP40

Fixed-Jaw Vise

40mm wide x 110mm long
1800 lbs clamping force



The MCP40 vise is extremely compact yet quite powerful. Like all of our 5-Axis vises, this vise has optimal features to allow unrestricted tool access for multiple-side machining. The standard fixed-jaw version has one fixed jaw and one sliding jaw that clamps against it. Due to its small size, the MCP40 vise uses an adaptor plate to mount on a Quintus 1 riser. **INFO+**: See our online catalog for more information.

MCP40 Z

Concentric Vise

40mm wide x 110mm long
1800 lbs clamping force



The Z-series version of our MCP40 vise is dimensionally similar, but incorporates our precision self-centering mechanism. This concentric vise has two sliding jaws that provide clamping at the exact center of the rotary table. **INFO+**: See our online catalog for more information.

MCP60

Fixed-Jaw Vise

60mm wide x 170mm long
3400 lbs clamping force

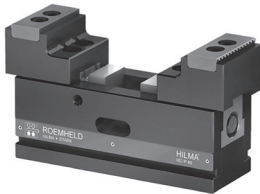

The MCP60 vise is our most popular 5-Axis-vise size. Like all of our 5-Axis vises, this vise has optimal features to allow unrestricted tool access for multiple-side machining. The standard fixed-jaw version has one fixed jaw and one sliding jaw that clamps against it. **INFO+**: See our online catalog for more information.

MCP60 Z

Concentric Vise

60mm wide x 170mm long
3400 lbs clamping force



The Z-series version of our MCP60 vise is dimensionally similar, but incorporates our precision self-centering mechanism. This concentric vise has two sliding jaws that provide clamping at the exact center of the rotary table. **INFO+**: See our online catalog for more information.

SCS80

Fixed-Jaw Vise

80mm wide x 200mm long
5600 lbs clamping force

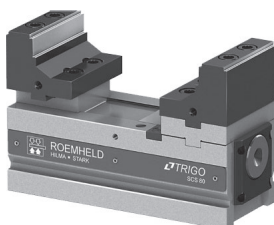

SCS-series vises are slightly wider, and allow clamping higher up in the jaws with greater holding force. Like all of our 5-Axis vises, the SCS80 vise has optimal features to allow unrestricted tool access for multiple-side machining. The standard fixed-jaw design has one fixed jaw and one sliding jaw that clamps against it. **INFO+**: See our online catalog for more information.

CL5® QUICK-CHANGE 5-AXIS WORKHOLDING

5-AXIS VISES FOR MOUNTING ON QUINTUS 2

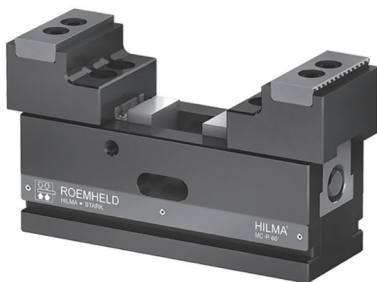

MCP100

Fixed-Jaw Vise

100mm wide x 260mm long
5600 lbs clamping force

The MCP100 vise handles a wide range of workpiece sizes. Like all of our 5-Axis vises, this vise has optimal features to allow unrestricted tool access for multiple-side machining. The standard fixed-jaw version has one fixed jaw and one sliding jaw that clamps against it. **INFO+**: See our online catalog for more information.



MCP100 Z

Concentric Vise

100mm wide x 266mm long
5600 lbs clamping force

The Z-series version of our MCP100 vise is dimensionally similar, but incorporates our precision self-centering mechanism. This concentric vise has two sliding jaws that provide clamping at the exact center of the rotary table. **INFO+**: See our online catalog for more information.

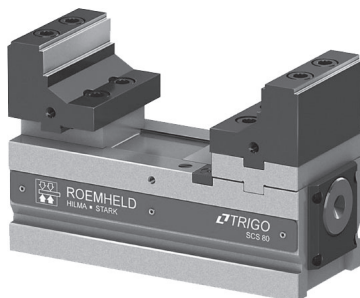

SCS120

Fixed-Jaw Vise

120mm wide x 227mm long
9000 lbs clamping force

SCS-series vises are slightly wider, and allow clamping higher up in the jaws with greater holding force. Like all of our 5-Axis vises, the SCS120 vise has optimal features to allow unrestricted tool access for multiple-side machining. The standard fixed-jaw design has one fixed jaw and one sliding jaw that clamps against it. **INFO+**: See our online catalog for more information.

5-AXIS VISES FOR MOUNTING ON QUINTUS 3

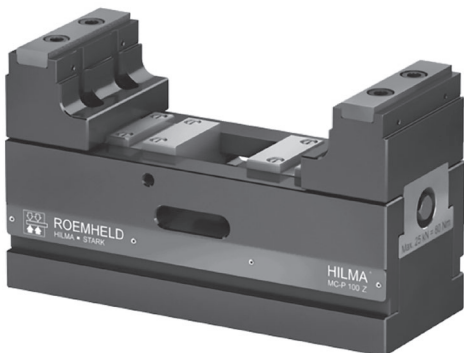

MCP125 Z

Concentric Vise

125mm wide x 465mm long
7900 lbs clamping force

The MCP125Z vise is ideal for large workpieces. Like all of our 5-Axis vises, this vise has optimal features to allow unrestricted tool access for multiple-side machining. This Z-series concentric vise incorporates our precision self-centering mechanism, with two sliding jaws that provide clamping at the exact center of the rotary table. Shown with optional tapered slides. **INFO+**: See our online catalog for more information.

CL5® QUICK-CHANGE 5-AXIS WORKHOLDING

DOVETAIL VISE JAWS

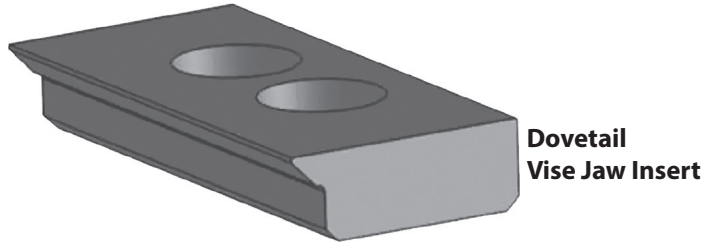

Dovetail Vise Jaw Insert

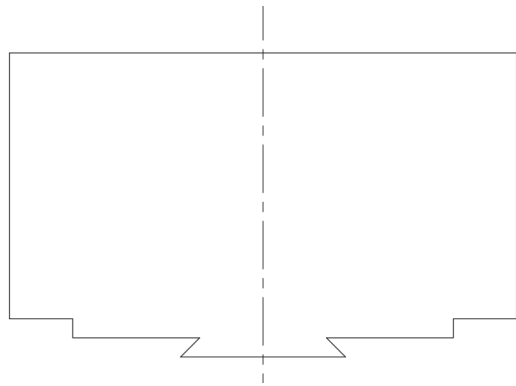
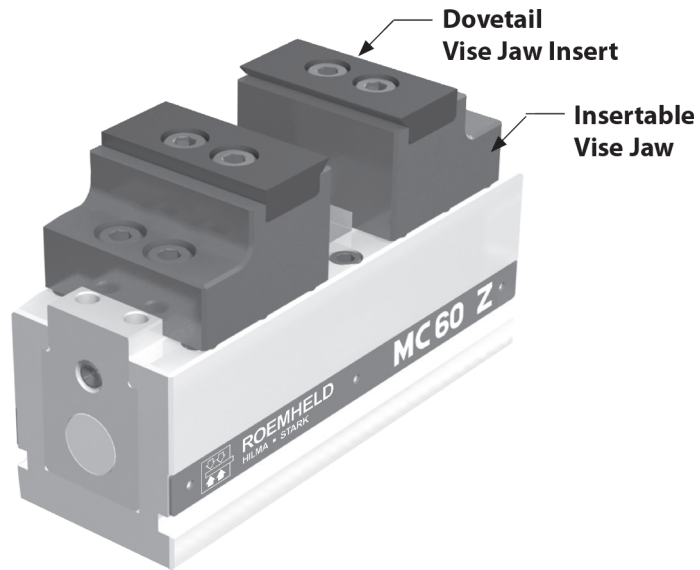

Example dovetail extension at bottom of workpiece.

Dovetail clamping requires leaving excess material at the bottom of each workpiece for machining a male dovetail. This machined dovetail extension is used to clamp on during 5-Axis work, by a mating dovetail clamp or vise jaw, then is removed in a secondary machining operation. The dovetail inserts shown here fit 60mm-wide insertable jaws on MCP60 and MCP60Z 5-Axis vises, with other sizes available upon request. Inserts are available for either 45-degree or 60-degree dovetails. 1018 steel, carburized-hardened, black oxide finish.

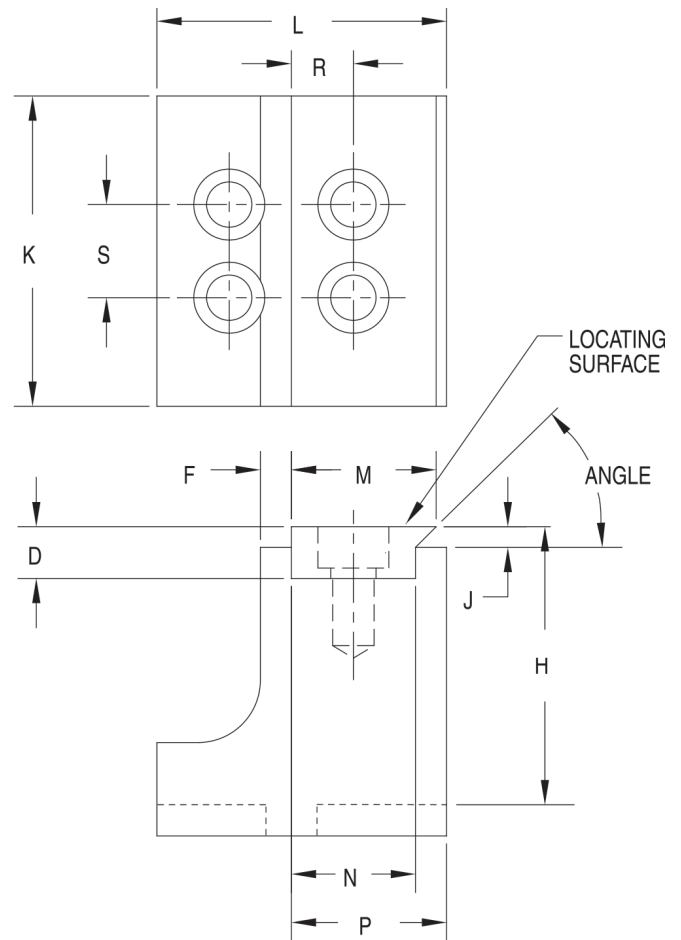

9

WISE JAWS AND DOVETAIL INSERTS

WISE JAW PART NO. (2 REQD)	INSERT PART NO. (2 REQD)	ANGLE	D	F	H	D	K	L	M	N	P	R	M
CLRH-9-3583-6906-VSA	CL-36-DVJI-45	45°	.394	.236	1.339	.157	2.362	2.205	1.102	.945	1.181	.472	.709
	CL-36-DVJI-60	60°							1.063				

CL5® QUICK-CHANGE 5-AXIS WORKHOLDING

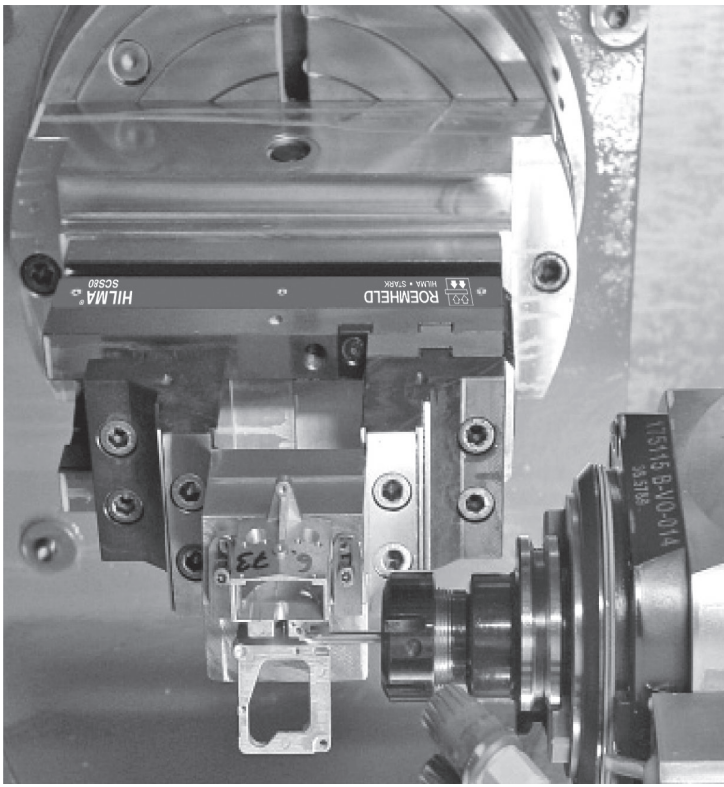
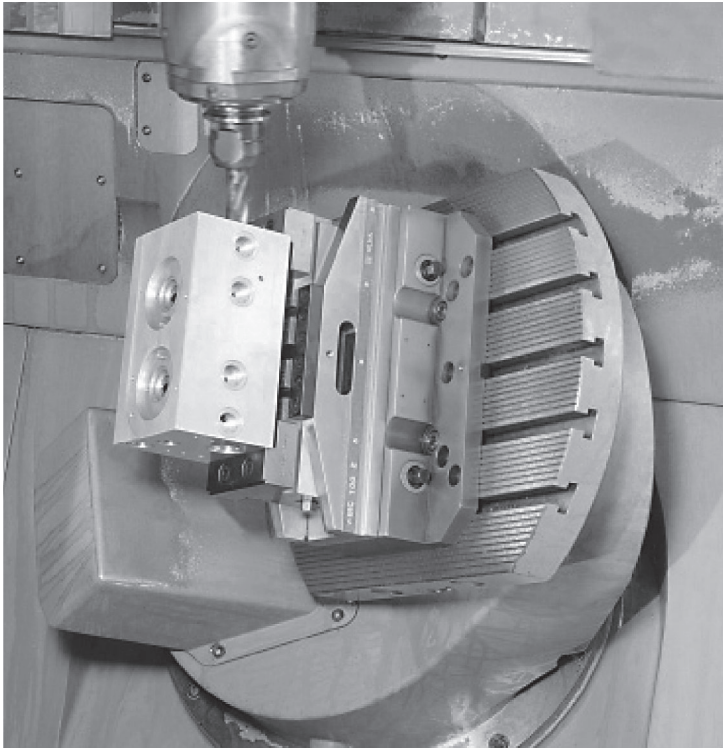

CL5[®] QUICK-CHANGE 5-AXIS WORKHOLDING

FIXTURE PLATES FOR MOUNTING ON QUINTUS 1

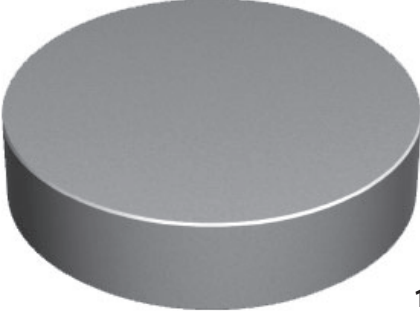

**130mm
Blank
(Mounts on Quintus 1)**

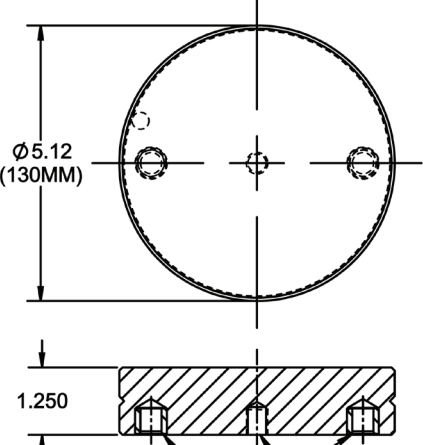

$\text{Ø}5.12$
(130MM)

1.250

(2) $\text{Ø}10\text{MM}$ HOLES
FOR QUINTUS 1
LOCATING PINS

M10 TAPPED HOLE
FOR QUINTUS 1
PULL-IN BOLT

PART NO.	TYPE	PLATE DIA	MOUNTS ON	WORKHOLDER OPTIONS
CL-130-00-QRFP	Blank	120mm	Quintus 1	Custom

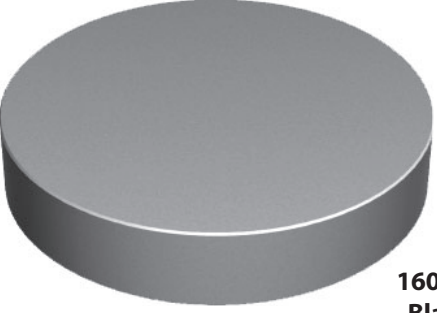

**160mm
Blank
(Mounts on Quintus 1)**

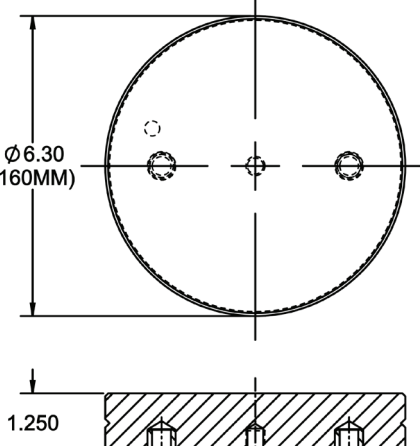

$\text{Ø}6.30$
(160MM)

1.250

(2) $\text{Ø}10\text{MM}$ HOLES
FOR QUINTUS 1
LOCATING PINS

M10 TAPPED HOLE
FOR QUINTUS 1
PULL-IN BOLT

PART NO.	TYPE	PLATE DIA	MOUNTS ON	WORKHOLDER OPTIONS
CL-160-00-QRFP	Blank	160mm	Quintus 1	Custom

CL5[®] QUICK-CHANGE 5-AXIS WORKHOLDING

FIXTURE PLATES FOR MOUNTING ON QUINTUS 1

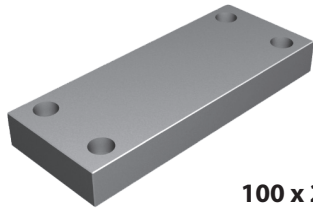

**100 x 250mm
Blank
(Mounts on Quintus 1)**

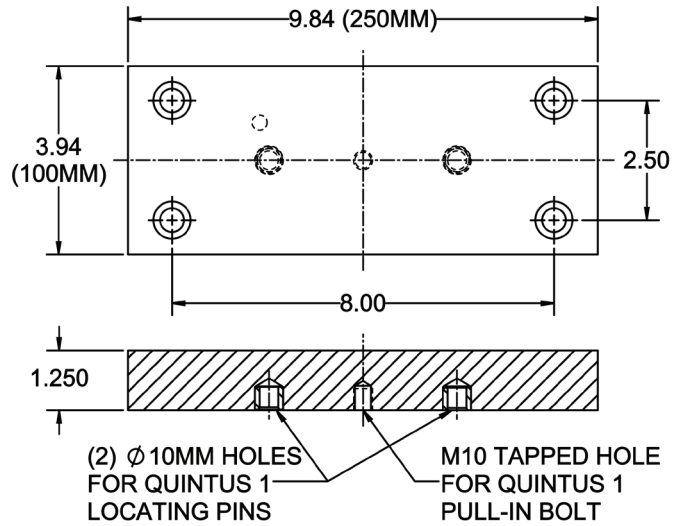

PART NO.	TYPE	PLATE SIZE	MOUNTS ON	WORKHOLDER OPTIONS
CL-100250-00-QFP	Blank	100 x 250mm	Quintus 1	Custom

9

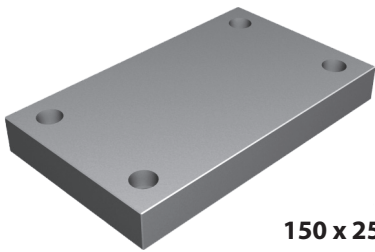

**150 x 250mm
Blank
(Mounts on Quintus 1)**

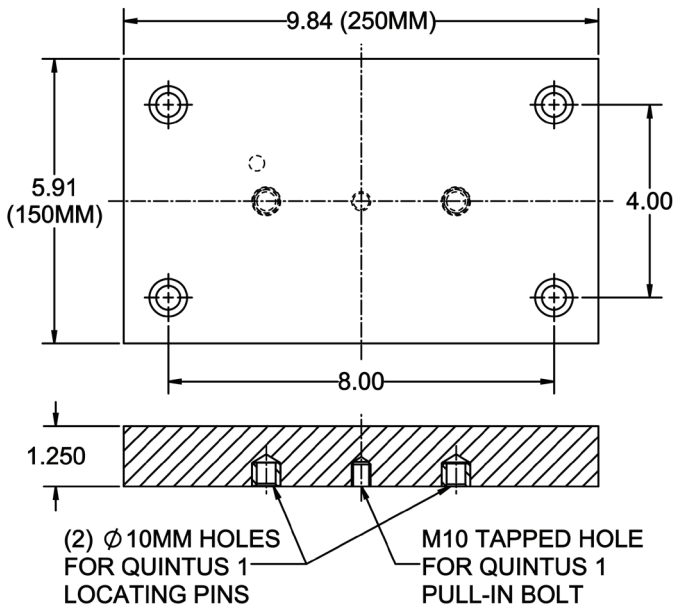

PART NO.	TYPE	PLATE SIZE	MOUNTS ON	WORKHOLDER OPTIONS
CL-150250-00-QFP	Blank	150 x 250mm	Quintus 1	Custom

CL5[®] QUICK-CHANGE 5-AXIS WORKHOLDING

SUBPLATES

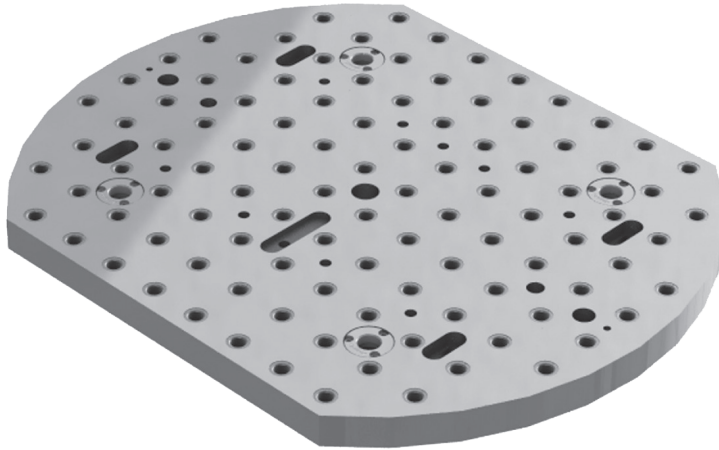

**630 x 500mm
Quintus 1, 2, 3,
Modular Fixturing
and Carr Lock**

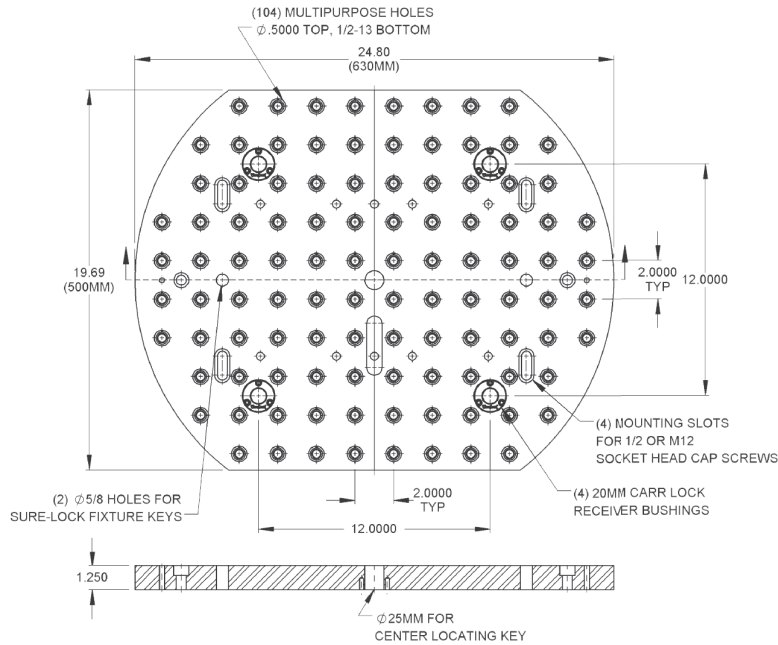

PART NO.	PLATE SIZE	FITS TABLE DIA	WORKHOLDER OPTIONS
CL-630500-44-CLRS	630 x 500mm	600mm 630 x 500mm	Quintus 1 with MC40, MC40Z, MC60, MC60Z, SCS80 Vise or Custom
			Quintus 2 with MC100, MC100Z, SCS120 Vise or Custom
			Quintus 3 with MC125Z Vise or Custom
			Riser Block with MC60, MC60Z, SCS80, MC100, MC100Z, SCS120 Vise or Custom
			Modular Fixture or Custom
			Carr Lock Fixture Plate

CL5® QUICK-CHANGE 5-AXIS WORKHOLDING

CENTER LOCATING KEYS

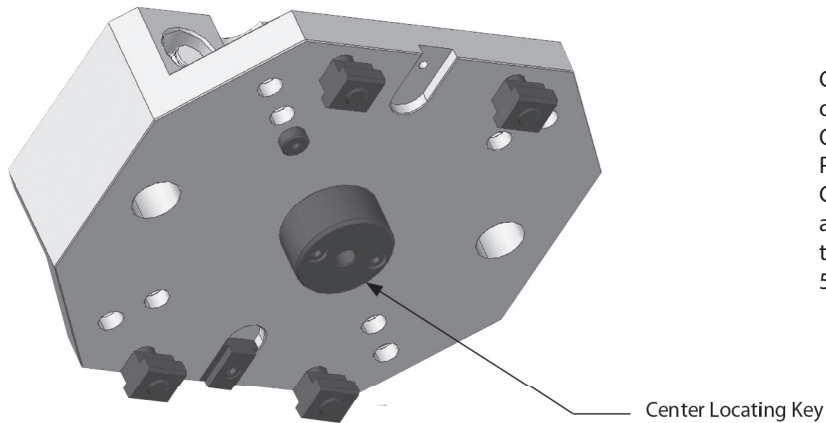

Center Locating Keys are used to precisely center a fixture on a rotary table. They can be used for mounting Quintus Quick-Change Risers, Riser Blocks, and Round Tooling Plates, which all have a standard 25mm center hole. All Center Locating Keys have a 25mm upper diameter and are available with a wide range of bottom diameters to fit the rotary table's center hole. 1144 steel, heat treated Rc 50-55, black oxide finish.

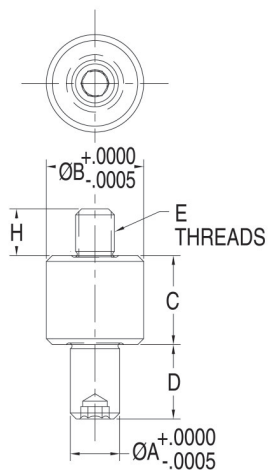

Type 1

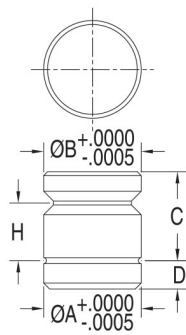

Type 2

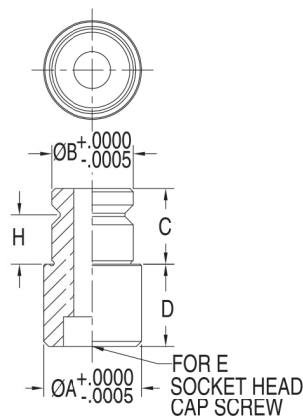

Type 3

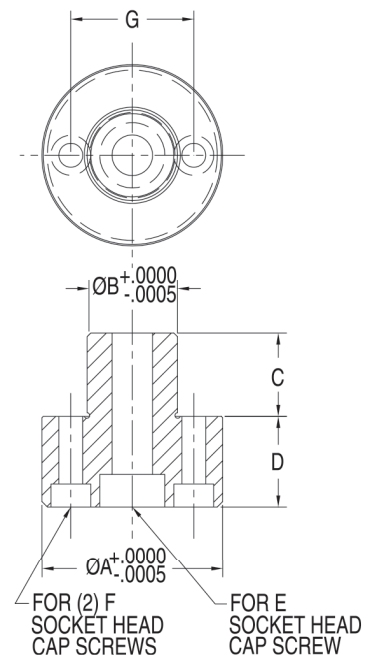

Type 4

CENTER LOCATING KEYS

PART NO.	TYPE	A DIA	B DIA	C	D	E	F	G	H
CLM-25-CLK-5000	Type 1	.5000	9.843 (25mm)	.90	.75	M10	—	—	.47
CLM-25-CLK-25	Type 2	.9843 (25mm)		.90	.29	—	—	—	.58
CLM-25-CLK-30	Type 3	1.1811 (30mm)		.91	.98	M10	—	—	.59
CLM-25-CLK-32		1.2598 (32mm)							
CLM-25-CLK-1.5000		1.5000							
CLM-25-CLK-50	Type 4	1.9685 (50mm)		.91	.98	M10	M6	1.339	—
CLM-25-CLK-70		2.000							
CLM-25-CLK-60		2.3622 (60mm)							
CLM-25-CLK-65		2.5591 (65mm)							
CLM-25-CLK-70		2.7559 (70mm)							
CLM-25-CLK-80		3.1496 (80mm)							
CLM-25-CLK-3.2500		3.2500							

DROPZERO™ MODULAR ZERO-POINT SYSTEM



- Reduces setup time and fixturing costs
- Modular design works with all of CLM's 1/2" and 5/8" modular tooling
- Can also be used with non-modular tooling
- Elevates workpiece for machine spindle clearance
- Access to all 5 sides of the part
- Stackable for added clearance
- High stability due to robust and wide design

New item!

With a few turns of a wrench, new DropZero Modular Zero-Point System quickly unloads and loads new parts in one setup, all while having access to all five sides of the workpiece. Pull studs (round, diamond, and floating) are mounted directly to a part, and clamp modules can be mounted to any fixture plate and can be stacked for added height. DropZero gives you better part quality due to a completely machined part in one setup, reduced fixturing costs, and simpler tool paths.

Application Examples

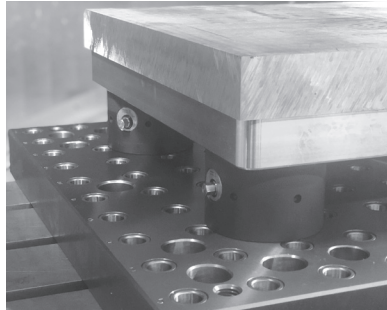

Four DropZeros mounted on a Carr Lane Mfg. modular fixturing plate holding an aluminum billet part.

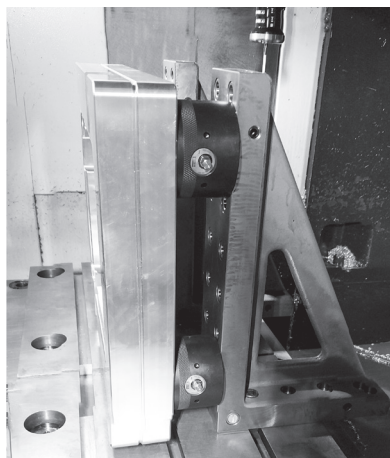

Example of side work for vertical applications.

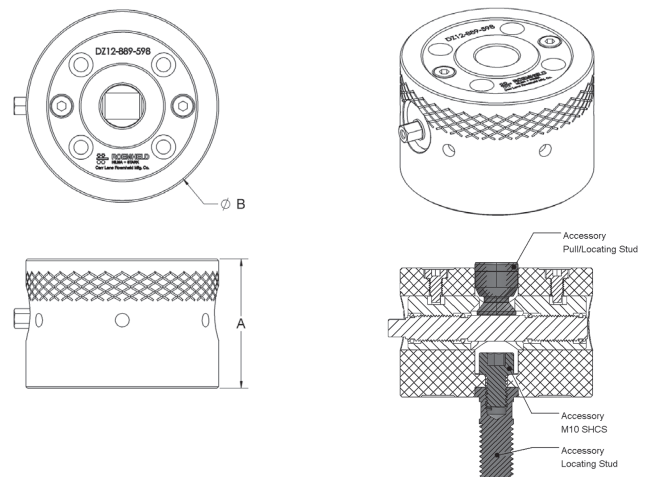

Operation	Manual
Type	Zero Point Mounting
Retention force (lbs) / Torque (ft-lbs)	2700 lbs/ 45 ft-lbs [12 kN/ 60 Nm]
A (in.)	2.35 ± 0.0004 in [59.8 ± 0.01 mm]
Ø B (in.)	3.50 in [88.9 mm]
Weight (lbs)	5.64 lbs [2.56 kg]
Part No.	CLR-DZ12-889-598
Pallet Change Repeatability	≤ 0.0004 in [0.01 mm]

Accessories

Part No., housing unit only	CLR-DZ12-889-598-H
Part No., zero-point locating stud/screw (1/2-13 UNC-2A)	CLR-DZ12T-500Z
Part No., zero-point locating stud/screw (5/8-11 UNC-2A)	CLR-DZ12T-625Z
Part No., socket-head cap screw	CLR-M10-1.50X16-SHCS
Part No., clamping spindle	CLR-DZ12M-25
Part No., zero-point pull stud	CLR-DZ12N-20Z
Part No., diamond pull stud	CLR-DZ12N-20D
Part No., floating pull stud	CLR-DZ12N-20F
Part No., floating pull stud without pallet/part, locating shoulder	CLR-DZ12N-195
Part No., locating dowel	CLR-DZ12D-15
Custom standoff	Available on request

Subject to change. For further details, including detailed dimensions and mounting instructions, visit roemheld-usa.com.

STARK ZERO-POINT MOUNTING SYSTEM

PRINCIPLES OF OPERATION

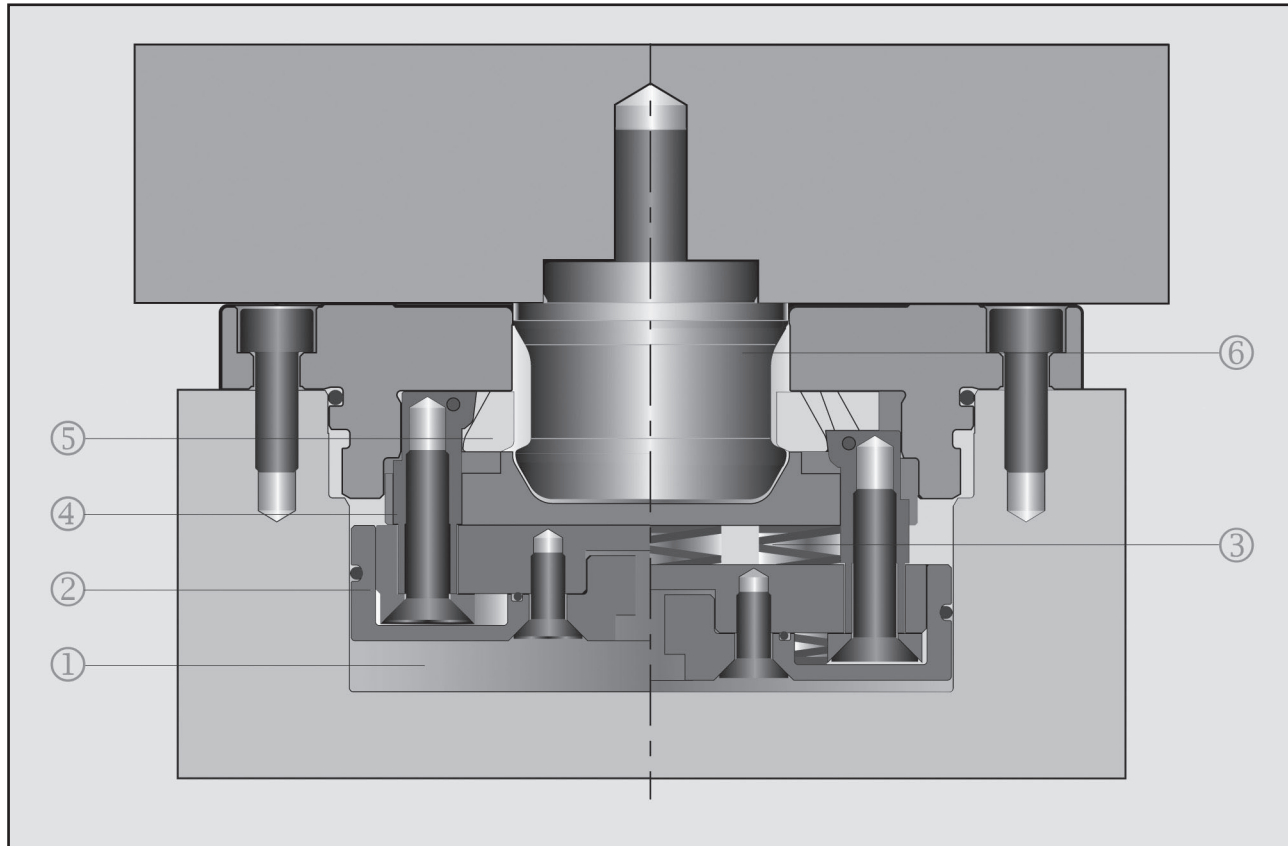

9

Releasing pneumatically:

- Pneumatic pressure (1) is applied to the piston (2) and the piston moves upward. The spiral springs (3) are pressed together.
- The clamping fingers (4) move upward through the piston (2) and pull the segments (5) to the outside.
- The retractable nipple (6) is released.

Clamping mechanically:

- The pneumatic pressure is relieved. The pneumatic pressure drops to zero.
- The spring pre-load is applied via the piston (2) and push the segments (5) toward the inside.
- The retractable nipple (6) is pulled down by the clamping face on the segments (5) and clamped against the bearing surface.

See our Online Catalog
at carrlane.com

STARK ZERO-POINT MOUNTING SYSTEM

FEATURES AND ADVANTAGES

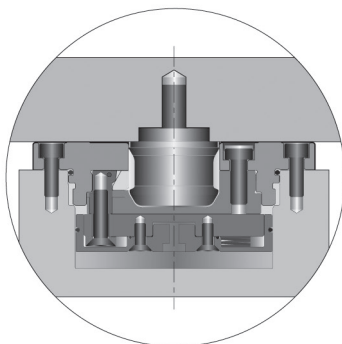

Design

- Compact design (Flush Mount, screw-fit or module)
- High retention force, enormous power density
- Maintenance-free, designed for large number of load changes (> 2 million in continuous test)
- Made of high quality tool steel and chromium steel
- Actuation with clean air, from 75psi to release
- Can be operated without additional service unit
- Environmentally friendly and clean operation (no oil)
- Particularly suitable for oil-free environment, e.g. in the foodstuffs, aerospace industry or medical sector.

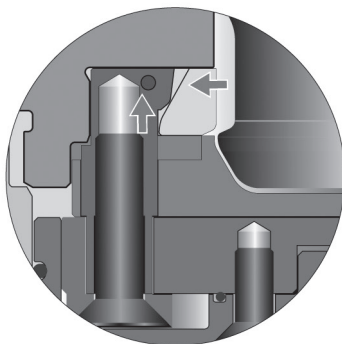

Positive action operation

- The segments are actuated mechanically
- Powerful and secure clamping is ensured at all times
- In an endurance test over 3 million clamping cycles tested full functionality even under extreme conditions.
- Functions reliably in any installation position
- Very short clamping and release time – 0.2sec

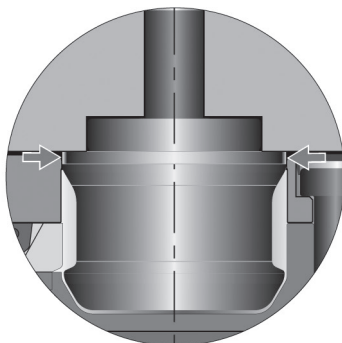

Cylindrical fit

- Due to the cylindrical fit, high lateral forces can be absorbed by the fast closing clamp during the machining
- Ideal pre-centring for Römheld coupling elements without coupling travel, data sheet F9.461

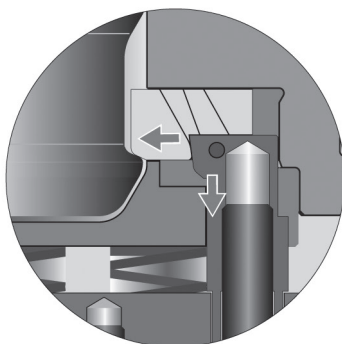

Segments

- Due to the optimal all-round positive clamping action of the clamping segments, the retractable nipple is retained stably and securely in the fast closing clamp.

**See our Online Catalog
at carrlane.com**

RECTANGULAR TOOLING PLATES

GRAY CAST IRON, ASTM CLASS 45

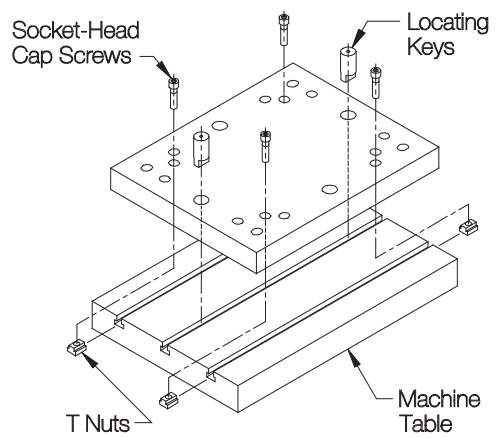
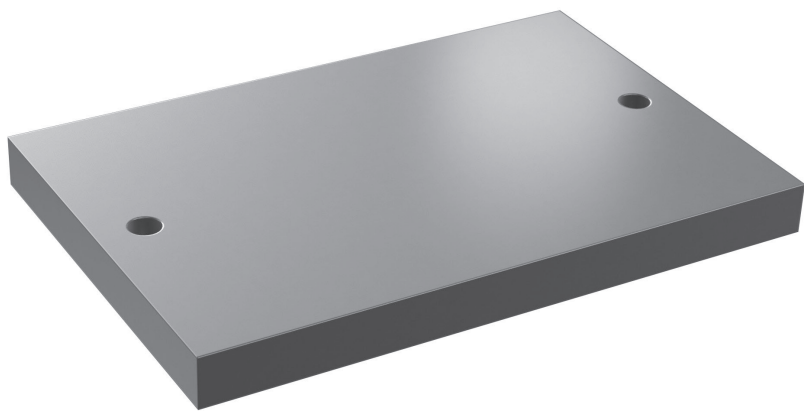

T-Slotted Table

Precision blank tooling plates that are ready to mount on virtually any vertical machining center, reducing tooling cost and leadtime considerably. Finish machined to tight tolerances. Precision Locating-Key holes allow accurate mounting directly on a machine table. Available in two standard fixture sizes.

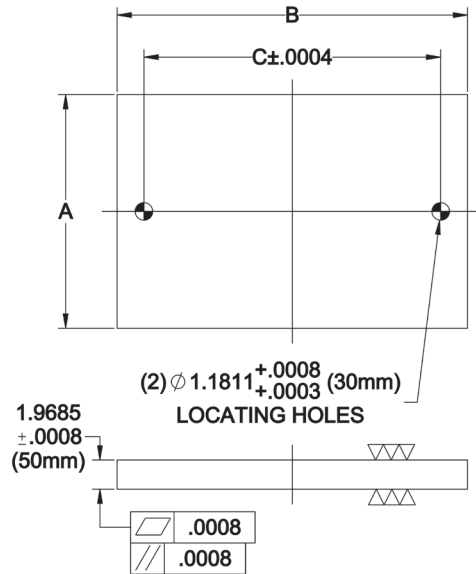

PART NO.	A		B		C	WEIGHT (lbs)
	NOMINAL	ACTUAL	NOMINAL	ACTUAL		
CL-1624-RTPB	16	15.75	24	23.62	20	188
CL-2024-RTPB	20	19.69	24	23.62	20	235

9

SQUARE PALLET TOOLING PLATES

GRAY CAST IRON, ASTM CLASS 45

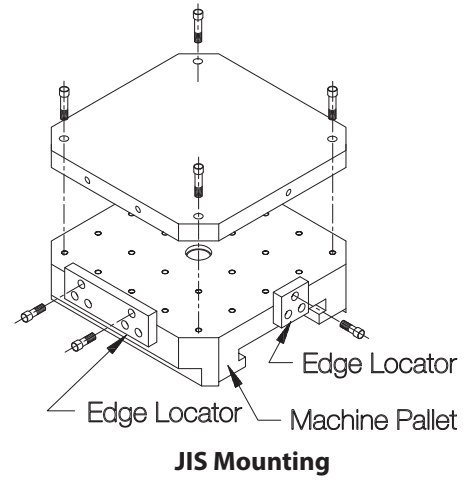
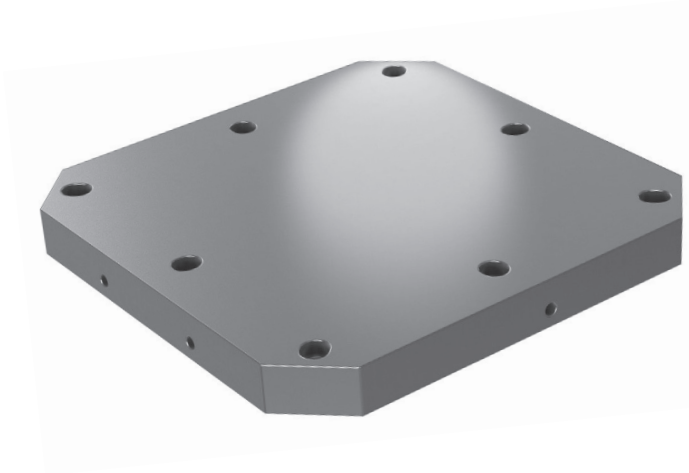

Precision blank tooling plates that are ready to mount on standard horizontal-machining-center pallets, reducing tooling cost and leadtime considerably. Finish machined to tight tolerances. JIS mounting from two reference edges provides accurate location.

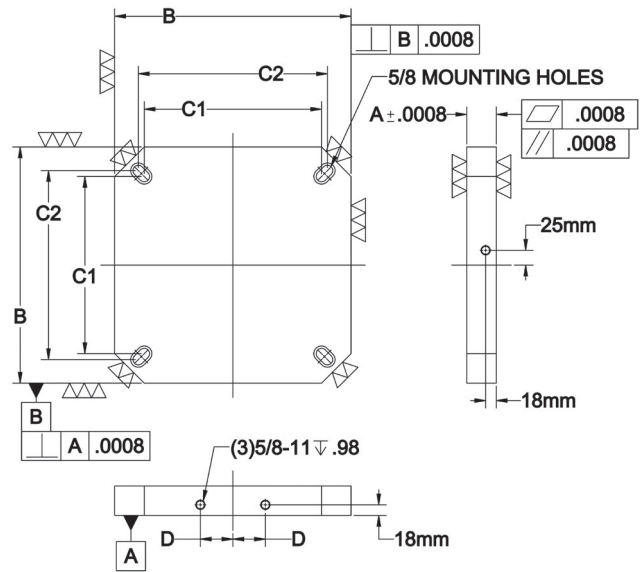

9

PART NO.	B PALLET SIZE		A HEIGHT		C1	C2	D	NO. OF MOUNTING HOLES	WEIGHT (lbs)
	NOMINAL	ACTUAL	NOMINAL	ACTUAL					
CL-400-PTPB	400mm	15.7480	50mm	1.9685	320mm	11.81	55mm	4	126
CL-500-PTPB	500mm	19.6850	50mm	1.9685	400mm	16	75mm	8	194

TWO-SIDED TOOLING BLOCKS

GRAY CAST IRON, ASTM CLASS 45



Extra Tall



Regular Height

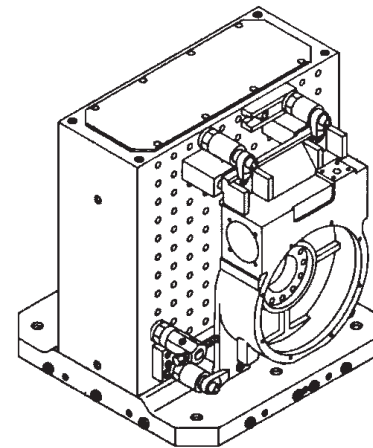

These tooling blocks have two identical wide faces to allow fixturing large parts.

Precision blank tooling blocks for horizontal-machining-center pallets. One-piece cast iron construction provides superior accuracy, dimensional stability, and vibration dampening. Both tooling faces are finish machined to tight tolerances and qualified to the base. Dual mounting capability allows both JIS mounting (locating from two reference edges) and DIN mounting (locating from center and radial holes) with excellent accuracy. Universal mounting holes fit almost any inch or metric slot spacing. Available in 400 and 500mm pallet sizes, each in a choice of heights.

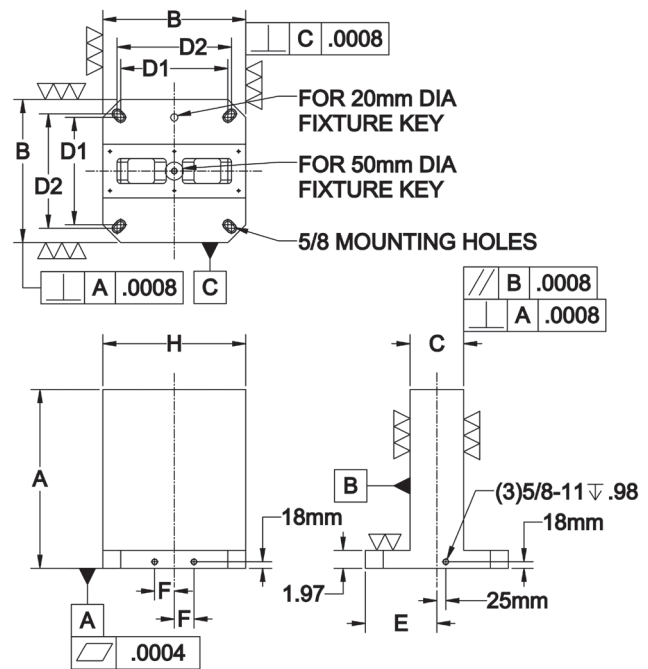

PART NO.	B PALLET SIZE		A HEIGHT		C		D1	D2	E	F	G	H	NO. OF MOUNTING HOLES	WEIGHT (lbs)
	NOMINAL	ACTUAL	NOMINAL	ACTUAL	NOMINAL	ACTUAL								
CL-400400500-TTBB	400mm	15.7480	500mm	19.69	150mm	5.9055	320mm	11.81	7.8740	55mm	1.97	15.75	4	375
CL-400400650-TTBB			650mm	25.59										520
CL-500500600-TTBB	500mm	19.6850	600mm	23.62	200mm	7.8740	400mm	16	9.8425	75mm	1.97	19.69	6	584
CL-500500750-TTBB			750mm	29.53										820

FOUR-SIDED TOOLING BLOCKS

GRAY CAST IRON, ASTM CLASS 45



Extra Tall



Regular Height

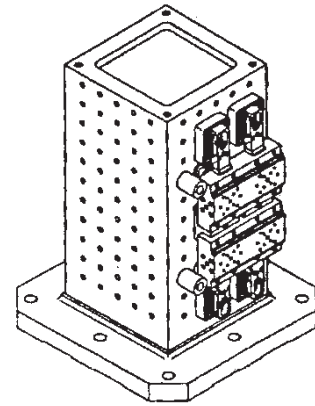

With four identical faces, these tooling blocks are ideal for loading a large number of medium-size parts on a pallet.

Precision blank tooling blocks for horizontal-machining-center pallets. One-piece cast iron construction provides superior accuracy, dimensional stability, and vibration dampening. All four faces are finish machined to tight tolerances and qualified to the base. Dual mounting capability allows both JIS mounting (locating from two reference edges) and DIN mounting (locating from center and radial holes) with excellent accuracy. Universal mounting holes fit almost any inch or metric slot spacing. Available in 400 and 500mm pallet sizes, each in a choice of heights.

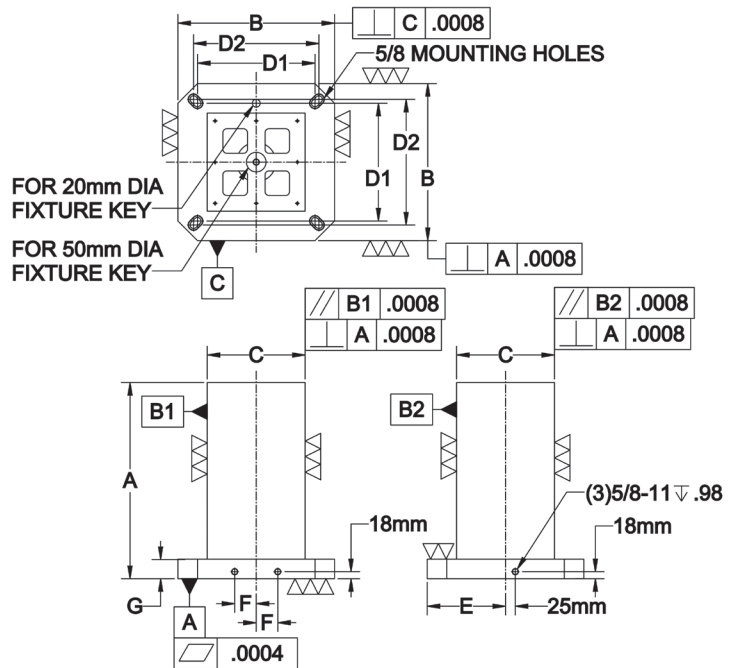

9

PART NO.	B PALLET SIZE		A HEIGHT		C		D1	D2	E	F	G	NO. OF MOUNTING HOLES	WEIGHT (lbs)
	NOMINAL	ACTUAL	NOMINAL	ACTUAL	NOMINAL	ACTUAL							
CL-400250500-FTBB	400mm	15.7480	500mm	19.69	250mm	9.8425	320mm	11.81	7.8740	55mm	1.97	4	337
CL-400250650-FTBB			650mm	25.59									481
CL-500300600-FTBB	500mm	19.6850	600mm	23.62	300mm	11.8110	400mm	16	9.8425	75mm	1.97	8	551
CL-500300750-FTBB			750mm	29.53									739

ANGLE BRACKETS

STEEL: ASTM A36, BLACK OXIDE FINISH
ALUMINUM: 6061-T6

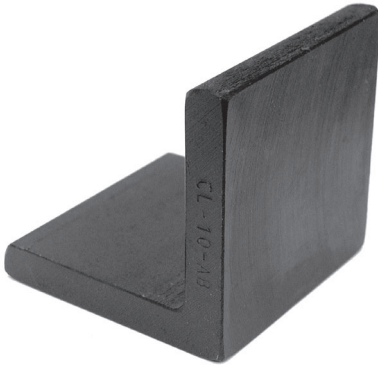

Precision setup angles machined flat and perpendicular to close tolerances. Available in steel or high-strength aluminum.

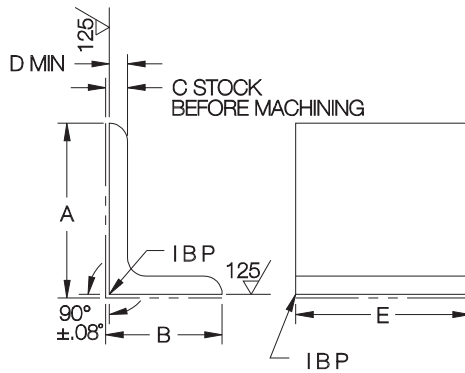

PART NO. STEEL	PART NO. ALUMINUM	A	B	C	D	E
CL-1-AB	—	2-1/2	2	1/4	7/32	1-1/2
CL-2-AB	CL-2-AB-A	2	2	3/8	5/16	2
CL-21-AB	—					3
CL-3-AB	CL-3-AB-A	3	2			4
CL-3A-AB	CL-3A-AB-A					2
CL-3B-AB	—	3	3			3
CL-22-AB	—					4
CL-5-AB	—	3	3	2		
CL-6-AB	—			3		
CL-7-AB	—	4	4	4		
CL-23-AB	—			6		
CL-8-AB	—	4	4	4		
CL-9-AB	—			2		
CL-10-AB	CL-10-AB-A	3	3	1/2	7/16	3
CL-11-AB	—					4
CL-7A-AB	—	4	3			2
CL-7B-AB	—					3
CL-12-AB	CL-12-AB-A	4	4			3
CL-13-AB	CL-13-AB-A					4
CL-14-AB	—	6	4	5		
CL-24-AB	—			6		
CL-15-AB	CL-15-AB-A	6	4	4		
CL-16-AB	—			5		
CL-17-AB	CL-17-AB-A	6	6	6		
CL-18-AB	—			4		
CL-19-AB	—	6	6	5		
CL-20-AB	CL-20-AB-A			6		

GUSSETED ANGLE BRACKETS

STEEL: ASTM A36, BLACK OXIDE FINISH
ALUMINUM: 6061-T6

9

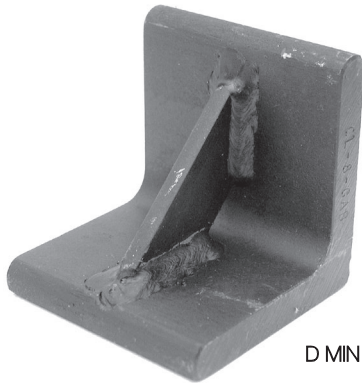

Similar to the Angle Brackets shown above, except with a gusset for added strength. Available in steel or high-strength aluminum.

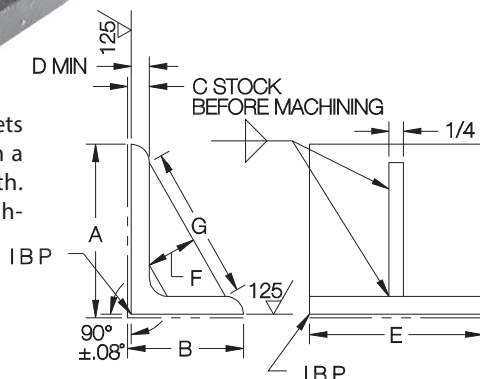

PART NO. STEEL	PART NO. ALUMINUM	A	B	C	D	E	F	G
CL-3A-GAB	—	3	2	3/8	5/16	2	7/8	2-3/4
CL-3B-GAB	—					3		
CL-1-GAB	—	3	3			2		
CL-2-GAB	—					3	1	3-7/16
CL-3-GAB	—	4	4			4		
CL-4-GAB	—					3	1	4-13/16
CL-5-GAB	—	4	4	4				
CL-7-GAB	—			2				
CL-8-GAB	CL-8-GAB-A	3	3	1/2	7/16	3	1	3-1/4
CL-9-GAB	—					4		
CL-7A-GAB	—	4	3			2	1-1/4	3-7/8
CL-7B-GAB	—					3		
CL-10-GAB	CL-10-GAB-A	4	4			3	1	4-5/8
CL-11-GAB	CL-11-GAB-A					4		
CL-12-GAB	—	6	4	5				
CL-13-GAB	CL-13-GAB-A			4	1-1/2	6-1/4		
CL-14-GAB	—	6	4	5				
CL-15-GAB	CL-15-GAB-A			6				
CL-16-GAB	—	6	6	4				
CL-17-GAB	—			5	1-1/2	7-7/16		
CL-18-GAB	CL-18-GAB-A	6	6	6				

ANGLE BRACKETS WITH LOCATING HOLES

ASTM A36 STEEL, BLACK OXIDE FINISH

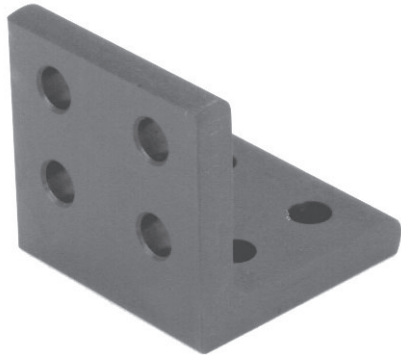

Angle Bracket

Extremely accurate angle brackets with precision locating holes. These angles are ideal for bolting together like an erector set to create large-scale tooling. The 90° angle and (8) locating holes are machined to close tolerances to maintain good accuracy in built-up tooling. Use with the precision locating bolts shown below.

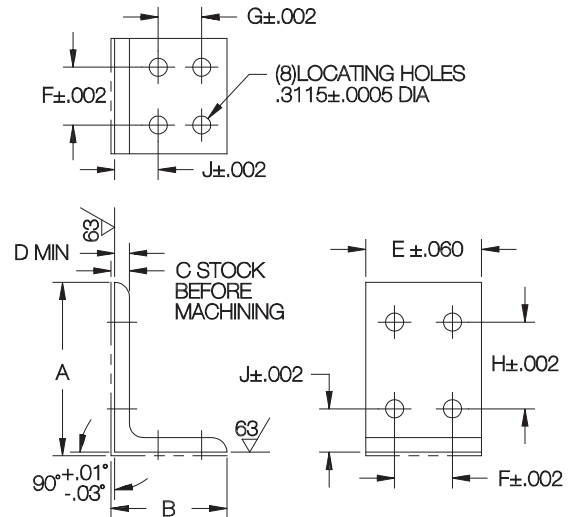

ANGLE BRACKETS

PART NO. STEEL	A	B	C	D	E	F	G	H	J
CL-1531-ABK	2	2	3/8	1/4	2	1.000	.750	.750	.750
CL-1532-ABK	3	2			4	3.000		.750	
CL-1535-ABK	2	2	1/2	3/8	3	2.000	1.250	1.250	1.125
CL-1539-ABK	3	3					2.000	2.000	1.000
CL-1533-ABK	4	4			2.000	2.000	1.125		
CL-15310-ABK	4	4			3.000	2.000	2.000	1.125	
CL-1534-ABK	6	4			1.500	3.500	1.500		

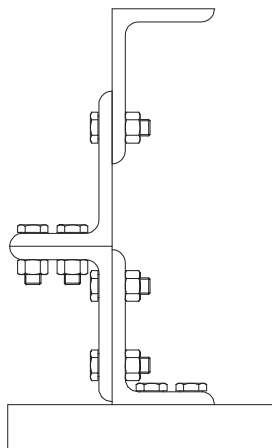

These high-precision angles can be bolted together to build economical large-scale tooling. Ideal for assembly and welding fixtures.

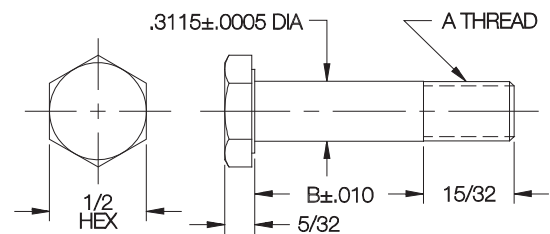

ANGLE BRACKET LOCATING BOLTS AND HEX NUTS

PART NO. LOCATING BOLT	PART NO. HEX NUT	A	B
CL-506-ABLB	CL-5-FHN	5/16-24	.375
CL-508-ABLB			.500
CL-510-ABLB			.625
CL-512-ABLB			.750
CL-516-ABLB			1.000



Angle Bracket Locating Bolt



Hex Nut

Precision bolts for fastening angle brackets to each other, and to other tooling. Ground locating diameter provides a slight press fit when angles are bolted together. Steel.

ADJUSTABLE ANGLES

1018 STEEL, BLACK OXIDE FINISH

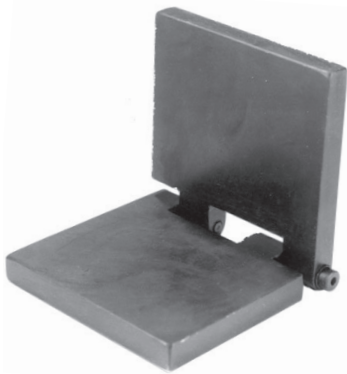

Plain

Precision angle with accurately machined sides and a close-tolerance hinge. Available either plain, with tabs for welding on a gusset, or with a removable pivot pin.
Patent no. 3,039,570.

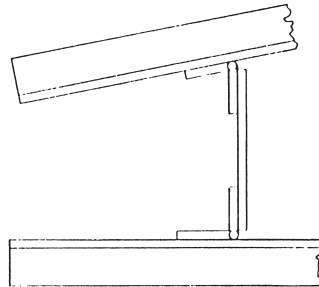
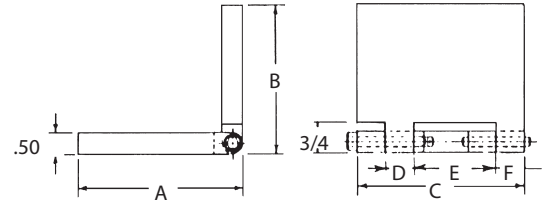

PLAIN

PART NO.	A	B	C	D	E	F
CL-AA-4P	3	3	3	5/8	1-1/8	5/8
CL-AA-1P	4	4	4	3/4	1-3/4	3/4

CAST SECTIONS

CAST IRON: ASTM CLASS 40, TENSILE STRENGTH 40,000 TO 45,000 PSI
 ALUMINUM: 352, TENSILE STRENGTH 30,000 PSI

9

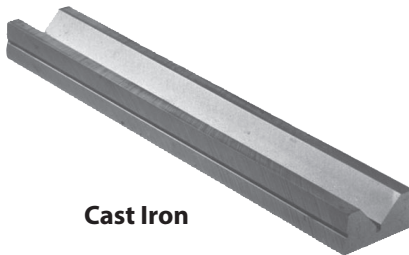

Cast Iron

Fast, economical way to make special fixture components. All surfaces are machined square and parallel within ± 0.005 inches per foot, except ends. Internal faces on square and rectangular sections are unfinished. All dimensions $\pm 1/32$ (except length, which is $-1/16$ to $+1/8$).

Cast sections are available in full lengths (usually 25") or 6" lengths. Custom lengths are available as specials.

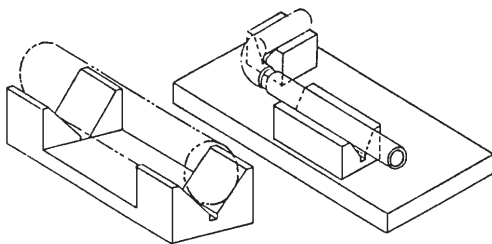
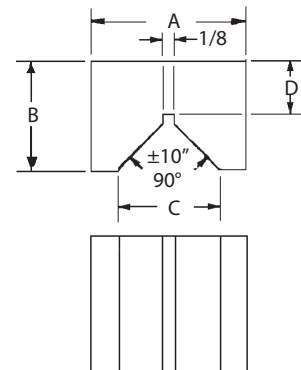

V SECTIONS — CAST IRON

PART NO.	A	B	C	D	FULL LENGTH
CL-1-CSV-18.00	2	1	1-1/4	5/16	18
CL-2-CSV-18.00	3	1-3/4	2	11/16	
CL-3-CSV-18.00	4	2-1/2	3	7/8	

HINGED BUSHING PLATES

BASE: A36 STEEL, CARBURIZE-HARDENED, BLACK OXIDE FINISH
 ARM: A36 STEEL, WEAR SURFACES HARD WELDED & GROUND, BLACK OXIDE FINISH
 PIVOT PIN: 4130 STEEL, HEAT TREATED, BLACK OXIDE FINISH

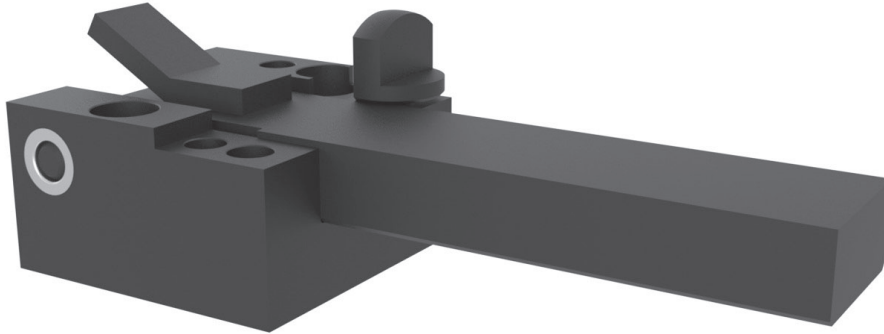

Complete Assembly

Hinged Bushing Plates are precise, heavy-duty bushing-plate assemblies for large-scale production jigs. The swing-away arm is precision ground but left unhardened for installing drill bushings (wear surfaces are hard welded and ground). The arm swings open a full 120° for loading clearance. The mounting base is hardened and precisely ground to provide accurate location. The base includes liner bushings as bearings for the hardened pivot pin, and a half-turn latch screw. Available in three sizes.

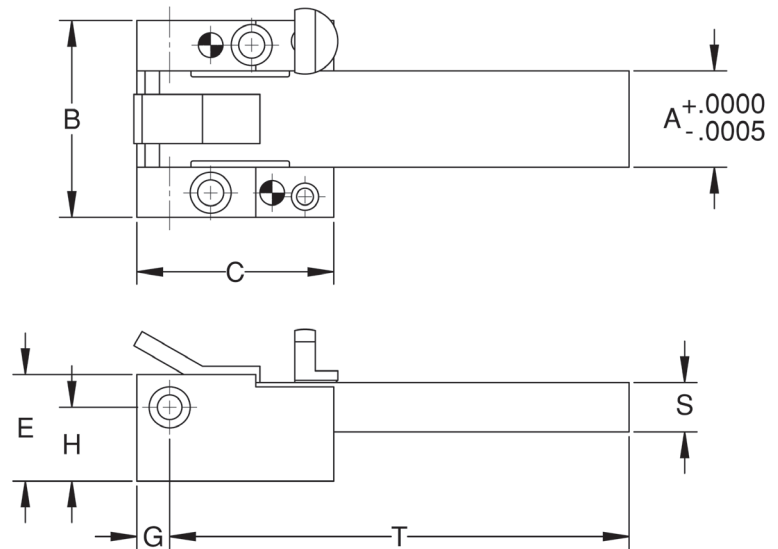

9

COMPLETE ASSEMBLY

PART NO.	A	B	C	E	G	H	S	T
CL-1-HBP	1.4675	3	3	1-5/8	.500	1.125	3/4	6.995
CL-2-HBP	1.9675	3-1/2	4	1-3/4	.500	1.250	1	9.500
CL-3-HBP	2.4675	4	5	2	.625	1.375	1-1/4	11.875

HINGED BUSHING PLATES

BASE: A36 STEEL, CARBURIZE-HARDENED, BLACK OXIDE FINISH
 ARM: A36 STEEL, WEAR SURFACES HARD WELDED & GROUND, BLACK OXIDE FINISH
 PIVOT PIN: 4130 STEEL. HEAT TREATED. BLACK OXIDE FINISH

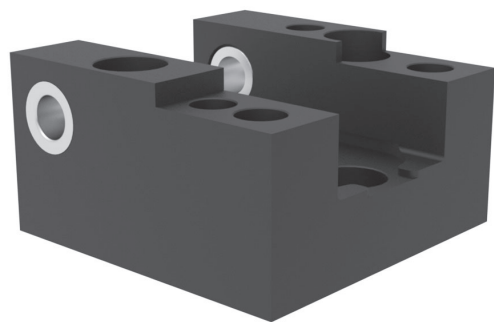

Base Only

The base can be ordered separately if customer-made arms will be used. The base kit shown here includes all hardware including the liner bushings, pivot pin, setscrew, and half-turn latch screw.

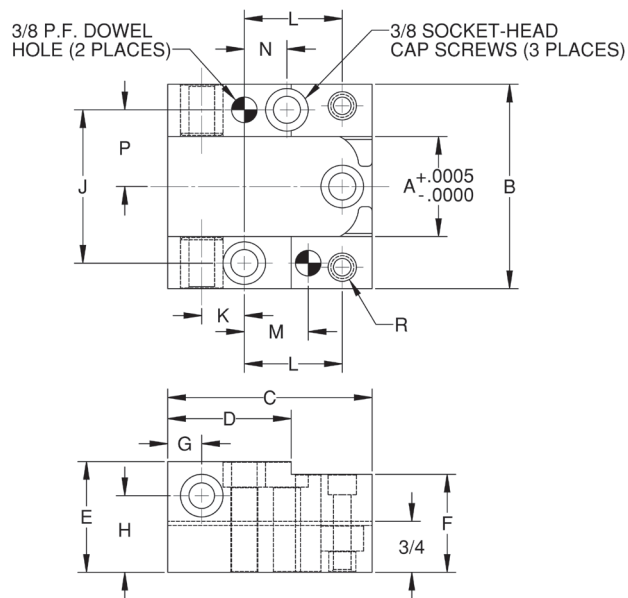

BASE KIT ONLY

PART NO.	A	B	C	D	E	F	G	H	J	K	L	M	N	P	R
CL-1-HBP-BK	1.468	3	3	1.81	1-5/8	1.43	.500	1.125	2.25	.625	1.438	.938	.625	1.125	5/16-18
CL-2-HBP-BK	1.968	3-1/2	4	2.50	1-3/4	1.68	.500	1.250	2.75	.750	2.250	1.500	.625	1.375	3/8-16
CL-3-HBP-BK	2.468	4	5	3.25	2	1.87	.625	1.375	3.25	.875	3.000	2.188	.750	1.625	1/2-13

9

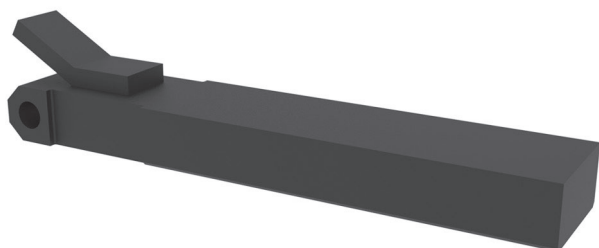

Arm Only

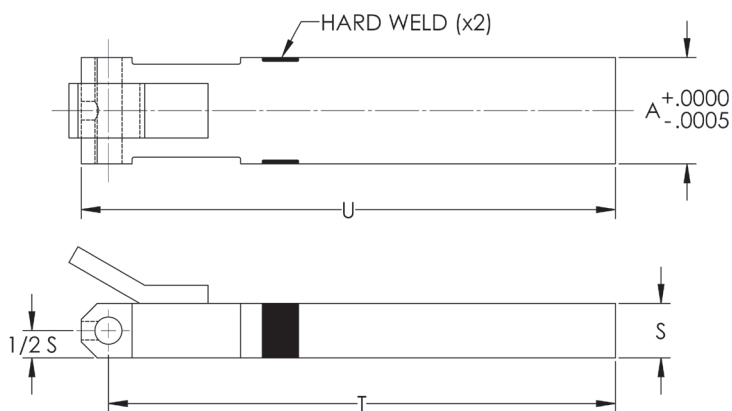

Arms can be ordered separately, to use as replacements or to switch tooling. The pivot pin can be easily removed by loosening the setscrew, allowing quick arm changeover.

ARM ONLY

PART NO.	A	S	T	U
CL-1-HBP-A	1.4675	3/4	7.00	7-3/8
CL-2-HBP-A	1.9675	1	9.50	10
CL-3-HBP-A	2.4675	1-1/4	11.88	12-1/2

MODULAR HINGE BUSHING PLATE

BASE & SIDE: MILD STEEL, CARBURIZE, BLACK OXIDE FINISH
 ARM: MILD STEEL, BLACK OXIDE FINISH



Modular Hinged Bushings Plates are precise, heavy-duty bushing-plate assemblies for large-scale production jigs. The Modular Hinged Bushing Plate can be ordered as a standard kit or configured to be customized to your application. The standard kit includes a hardened steel base with ground steel rest pads installed for accurate location, steel sides with installed liner bushings as bearings for the hardened pivot pin, and a swing-away arm that is left unhardened for customer modifications. The arm swings freely but can be locked at 100 deg with the optional locking mechanism. Additional locking options allow for the arm to be locked in the closed position. Fine adjustment of the arm position can be made using a Ball-Ended Thrust Screw for optimal alignment. Modular Hinged Bushings Plates are available in two sizes. Made in USA.

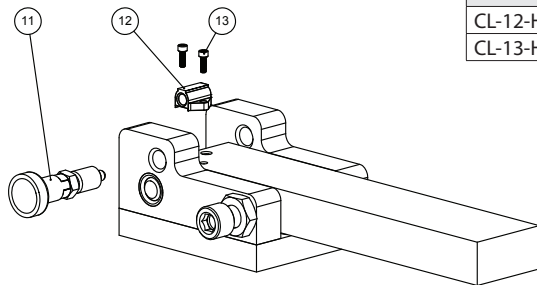
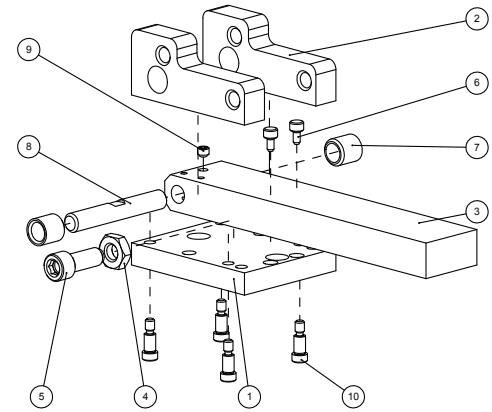
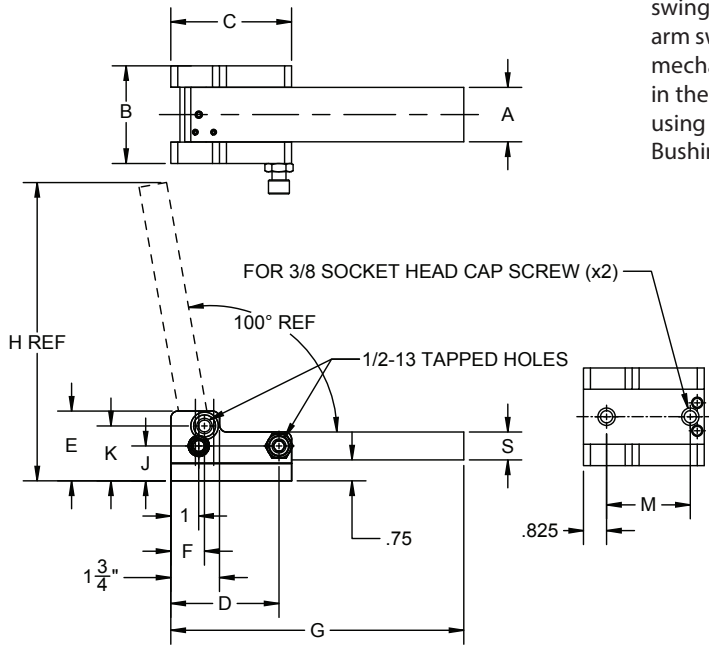

OPTIONAL LOCKING ELEMENT

PART NO.	A	B	C	D	E	F	G	H	J	K	M
CL-12-HBP	1.95	3.5	4.33	3.88	2-1/2	1.21	10.5	10.7	1-1/4	1.97	3.00
CL-13-HBP	2.45	4.0	5.33	4.83	2-5/8	1.33	12.875	13.3	1-3/8	2.22	4.00

See website for full list of materials and available options.

TRUNNIONS

ARM: TENZALOY ALUMINUM ALLOY
 BODY: ALUMINUM WITH BRONZE BEARINGS, POWDER-COATED EXTERIOR

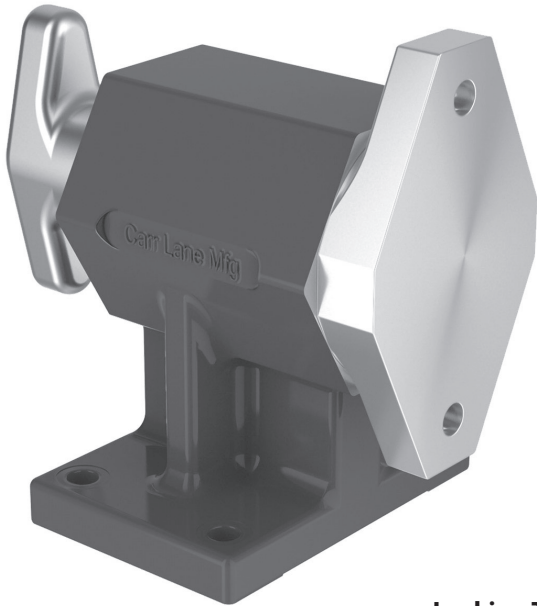

Locking Type

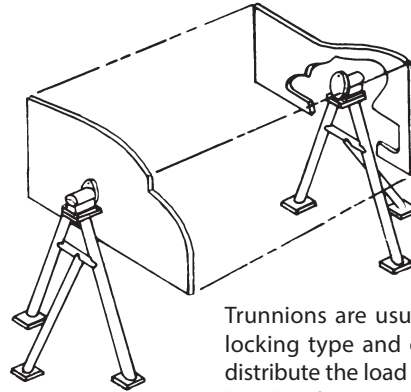

Trunnions are usually used in pairs, one locking type and one revolving type, to distribute the load between them without bending forces.

Trunnions are rugged, precision bearing mounts for revolving fixtures. Ideal for assembly and welding fixtures, and any other applications where the part must be accessible from all sides. Usually used in pairs, one locking Trunnion and one revolving Trunnion, to distribute the load between them without bending forces. The locking version, shown here, has a friction-cone mechanism that stops the rotor at any angle by tightening the knob handle (loosen knob again to unlock). The revolving version has a free-rotating bearing at both ends of the rotor shaft, with no locking mechanism. Choice of two sizes. **Patent no. 3,129,937.** Made in USA.

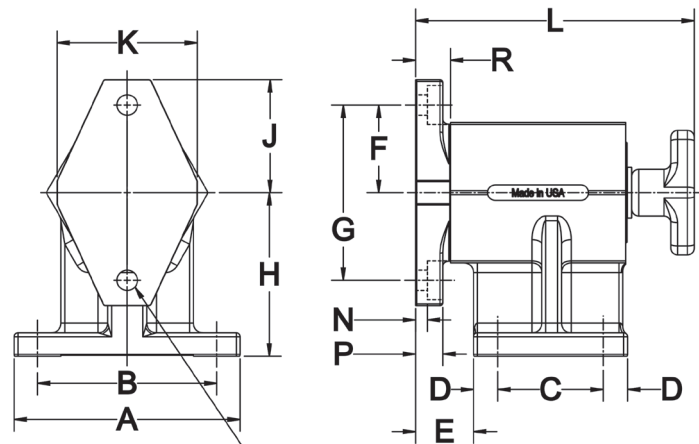

(6) MOUNTING HOLES FOR M DIA SCREWS

LOCKING TYPE

PART NO.	LOAD CAPACITY (18" from face)	A	B	C	D	E	F	G	H	J	K	L	M	N	P	R
CL-100-TL	1800 lbs	5	4	2-3/8	1/2	1-3/8	2	4	4	2-5/8	3-1/4	7	3/8 or M10	.33	5/8	13/16
CL-200-TL	2500 lbs	7-1/4	5-3/4	3-3/8	3/4	1-7/8	2-13/16	5-5/8	5-1/4	3-3/4	4-1/4	9	5/8 or M16	.38	7/8	1-1/8

TRUNNIONS

ARM: TENZALOY ALUMINUM ALLOY
 BODY: ALUMINUM WITH BRONZE BEARINGS, POWDER-COATED EXTERIOR



Revolving Type

Trunnions are rugged, precision bearing mounts for revolving fixtures. Ideal for assembly and welding fixtures, and any other applications where the part must be accessible from all sides. Usually used in pairs, one locking Trunnion and one revolving Trunnion, to distribute the load between them without bending forces. The locking version has a friction-cone mechanism that stops the rotor at any angle by tightening the knob handle (loosen knob again to unlock). The revolving version, shown here, has a free-rotating bearing at both ends of the rotor shaft, with no locking mechanism. Choice of two sizes. **Patent no. 3,129,937.** Made in USA.

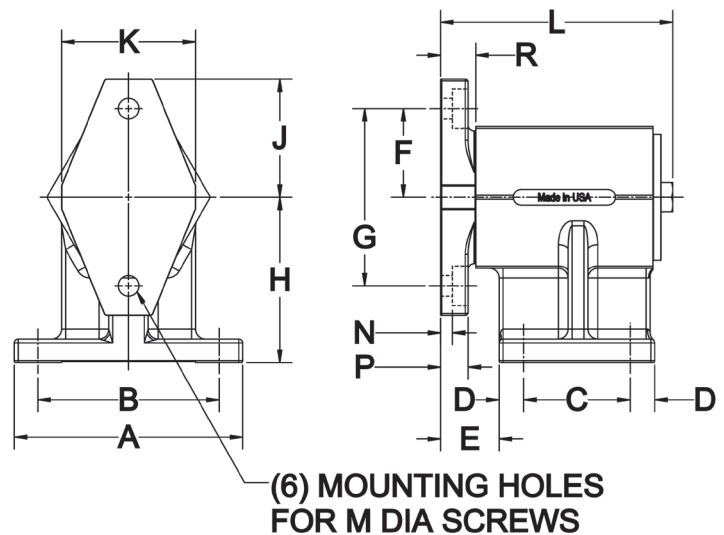

REVOLVING TYPE

PART NO.	LOAD CAPACITY (18" from face)	A	B	C	D	E	F	G	H	J	K	L	M	N	P	R
CL-100-TR	1800 lbs	5	4	2-3/8	1/2	1-3/8	2	4	4	2-5/8	3-1/4	5-7/16	3/8 or M10	.33	5/8	13/16
CL-200-TR	2500 lbs	7-1/4	5-3/4	3-3/8	3/4	1-7/8	2-13/16	5-5/8	5-1/4	3-3/4	4-1/4	7-5/8	5/8 or M16	.38	7/8	1-1/8

TECHNICAL INFORMATION ADJUSTABLE LOCKING HUBS

TYPES AVAILABLE



Heavy-Duty—Stainless Steel
Two Round Ends
INFO+: Page 399



Heavy-Duty—Stainless Steel
Two Mounting Flanges
INFO+: Page 400



Heavy-Duty—Stainless Steel
Mounting Flange & Round End
INFO+: Page 401

APPLICATION EXAMPLES

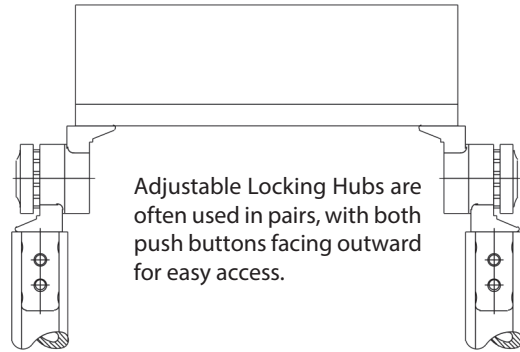

Adjustable Locking Hubs are often used in pairs, with both push buttons facing outward for easy access.

Connect two Adjustable Locking Hubs at 90° (with pipe or tubing) for full 5-Axis positioning.

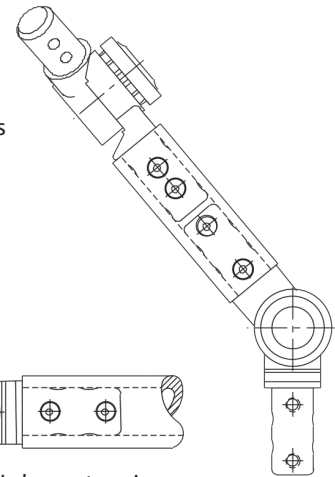

Hub extensions allow convenient mounting to flat plates and angles, as well as to pipe and tubing.

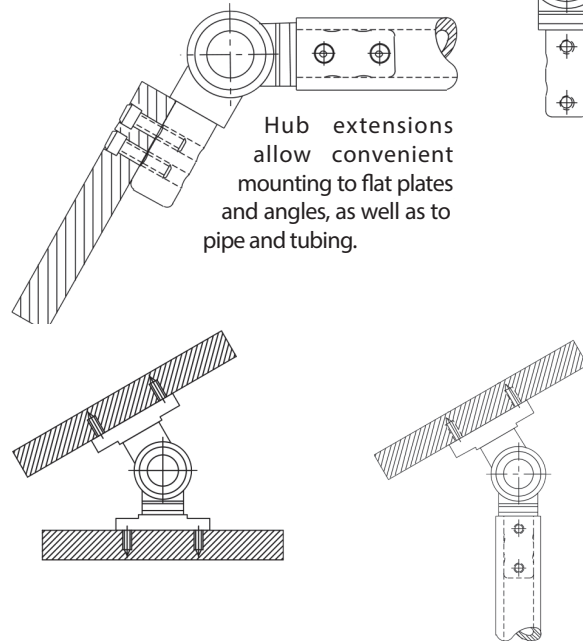

Mounting flanges are ideal for attaching Adjustable Locking Hubs to flat surfaces. Heavy-duty hubs are available with either two mounting flanges, or one mounting flange and one round end.

9

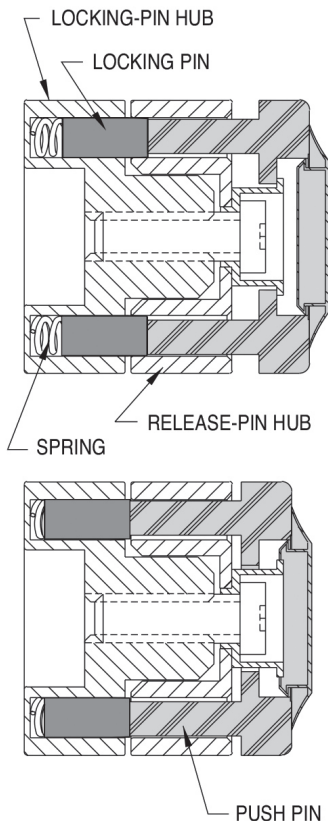

Locked

In locked position, the locking-pin hub and release-pin hub are positively engaged by high-strength locking pins.

Unlocked

When the release button is pressed, against spring force, push pins force the locking pins to disengage. The hub is now free to rotate. After reaching the desired angle, releasing the button again allows the locking pins to extend back into locked position.

ADJUSTABLE LOCKING HUBS

BODY: 300-SERIES STAINLESS STEEL, ELECTRO POLISHED. PINS: 416 STAINLESS STEEL, HEAT TREATED
RELEASE BUTTON: BLACK THERMOPLASTIC.

US PATENT NO. 5,586, 363 AND 5,689,999. OTHER PATENTS PENDING.

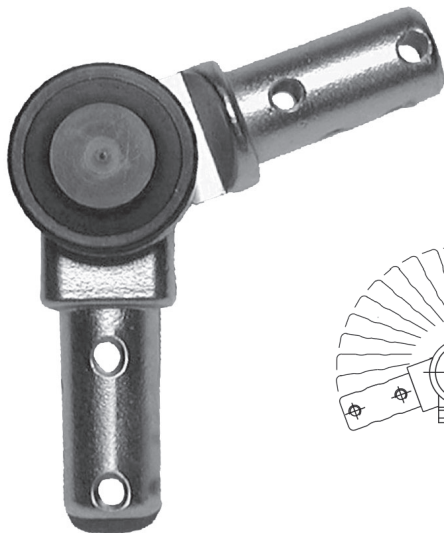

**Heavy Duty—
Stainless Steel
Two Round Ends
Inline
(220° Adjustment)**

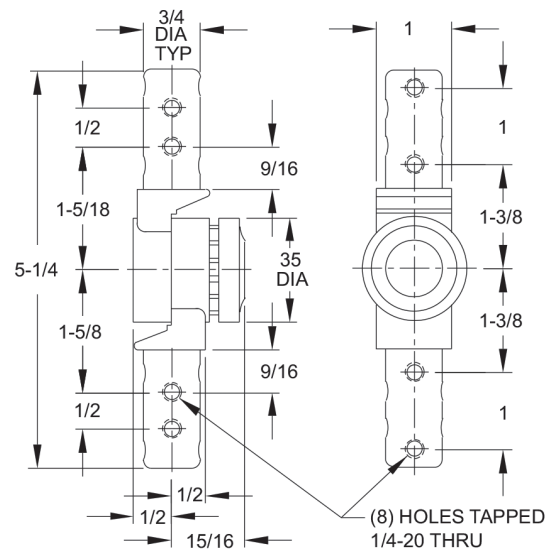
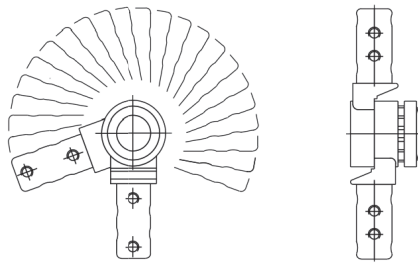

Adjustable Locking Hubs are rotary bearings that provide positive locking at any 10° increment. Once locked, the hub becomes an absolutely rigid joint, able to withstand 80 ft.-lbs. of torque (5:1 safety factor). Round Hub extensions fit 3/4" ID pipe or tubing. The tapped mounting holes can also be used to attach a plate or angle. Applications include adjustable fixtures, rotating fixtures, welding fixtures, trunnion mounting, adjustable and/or foldable handles, adjustable part trays and shelves, adjustable and/or flip-up work surfaces, positive positioning of spotlights or nozzles, and collapsible structures. Also available in alloy steel with a black finish (CL-100-ALH).

INLINE (220° ADJUSTMENT)

PART NO.	TOTAL ADJUSTMENT RANGE	ADJUSTMENT INCREMENTS	ALLOWABLE TORQUE (FT-LB)
CL-100-ALH-S	220°	10°	80

Your source for metric



Carr Lane
MANUFACTURING CO.

ADJUSTABLE LOCKING HUBS

BODY: 300-SERIES STAINLESS STEEL, ELECTRO POLISHED. PINS: 416 STAINLESS STEEL, HEAT TREATED
RELEASE BUTTON: BLACK THERMOPLASTIC.

US PATENT NO. 5,586, 363 AND 5,689,999. OTHER PATENTS PENDING.



**Heavy Duty—
Stainless Steel
Two Mounting Flanges
Inline
(180° Adjustment)**

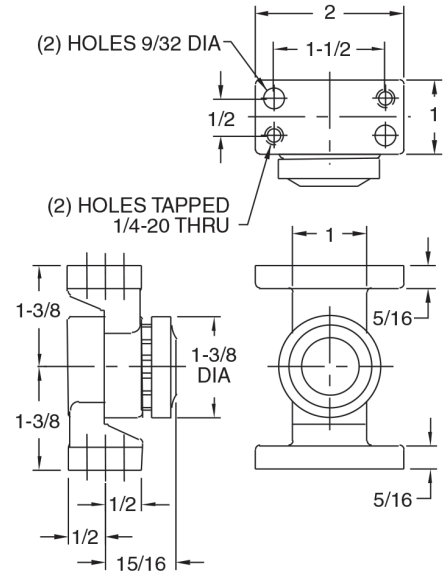
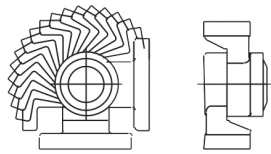

Adjustable Locking Hubs are rotary bearings that provide positive locking at any 10° increment. Once locked, the hub becomes an absolutely rigid joint, able to withstand 80 ft.-lbs. of torque (5:1 safety factor). Mounting flanges provide two mounting options: (1) two 1/4-20 tapped holes allow fastening an object to the mounting flange; (2) two 9/32 dia clearance holes for 1/4" screws allow fastening the mounting flange to a surface. Applications include adjustable fixtures, rotating fixtures, welding fixtures, trunnion mounting, adjustable and/or foldable handles, adjustable part trays and shelves, adjustable and/or flip-up work surfaces, positive positioning of spotlights or nozzles, and collapsible structures.

INLINE (180° ADJUSTMENT)

PART NO.	TOTAL ADJUSTMENT RANGE	ADJUSTMENT INCREMENTS	ALLOWABLE TORQUE (FT-LB)
CL-120-ALH-S	180°	10°	80

9

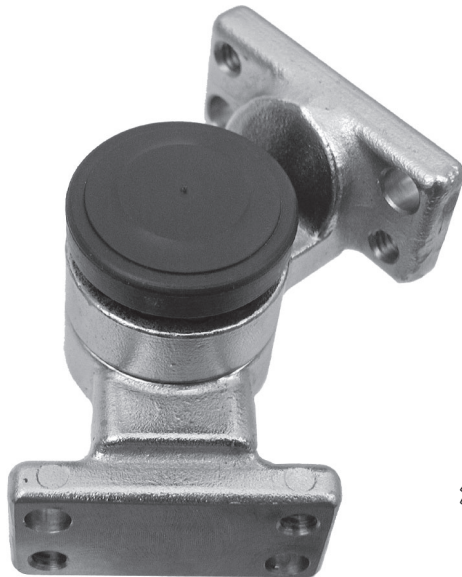

**Heavy Duty—
Stainless Steel
Two Mounting Flanges
Offset
(360° Rotation)**

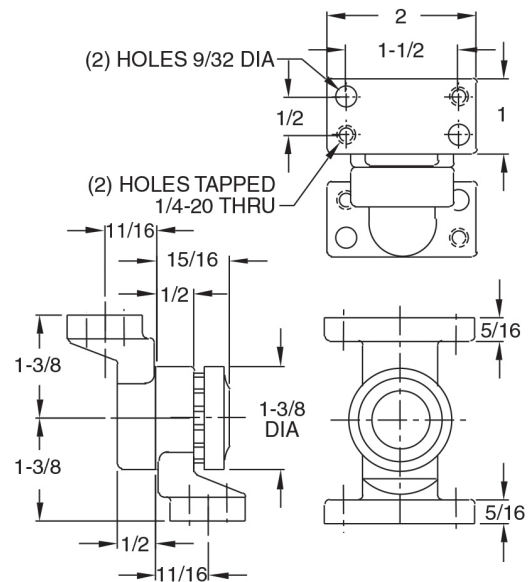
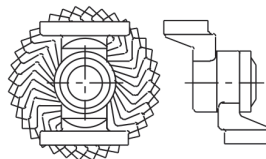

Similar to the Locking Hub above, except hub extensions are offset to allow full 360° rotation. Offset Locking Hubs should usually be used in pairs, to avoid off-center loading on a single hub. Make sure that rotating loads are balanced and avoid any possible pinch points, in case hubs are suddenly unlocked and the load is allowed to rotate freely.

OFFSET (360° ROTATION)

PART NO.	TOTAL ADJUSTMENT RANGE	ADJUSTMENT INCREMENTS	ALLOWABLE TORQUE (FT-LB)
CL-121-ALH-S	360°	10°	80

ADJUSTABLE LOCKING HUBS

BODY: 300-SERIES STAINLESS STEEL, ELECTRO POLISHED. PINS: 416 STAINLESS STEEL, HEAT TREATED
RELEASE BUTTON: BLACK THERMOPLASTIC.

US PATENT NO. 5,586,363 AND 5,689,999. OTHER PATENTS PENDING.

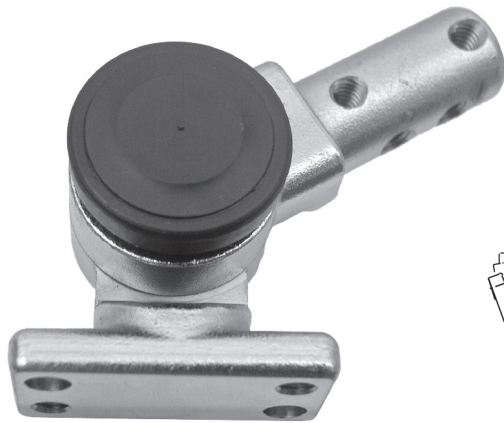

**Heavy Duty—
Stainless Steel
Mounting Flange &
Round End Inline
(220° Adjustment)**

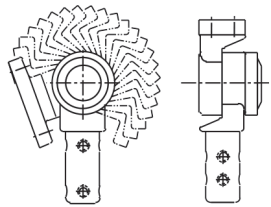

Adjustable Locking Hubs are rotary bearings that provide positive locking at any 10° increment. Once locked, the hub becomes an absolutely rigid joint, able to withstand 80 ft.-lbs. of torque (5:1 safety factor). The round hub extension fits 3/4" ID pipe or tubing. The tapped mounting holes can also be used to attach a plate or angle. The mounting flange provides two mounting options: (1) two 1/4-20 tapped holes allow fastening an object to the mounting flange; (2) two 9/32 dia clearance holes for 1/4" screws allow fastening the mounting flange to a surface. Applications include adjustable fixtures, rotating fixtures, welding fixtures, trunnion mounting, adjustable and/or foldable handles, adjustable part trays and shelves, adjustable and/or flip-up work surfaces, positive positioning of spotlights or nozzles, and collapsible structures.

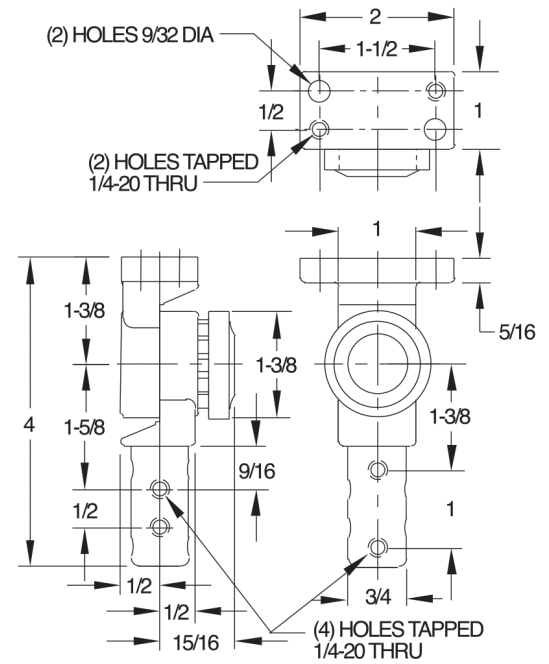

INLINE (220° ADJUSTMENT)

PART NO.	TOTAL ADJUSTMENT RANGE	ADJUSTMENT INCREMENTS	ALLOWABLE TORQUE (FT-LB)
CL-110-ALH-S	220°	10°	80

MODULAR FIXTURING



**Modular Tooling Plates
& Blocks**



**Mounting
Accessories**



**Modular Supports
& Locators**



Modular Clamps

Also see:



**Drop Zero Modular
Zero-Point System
p. 658**

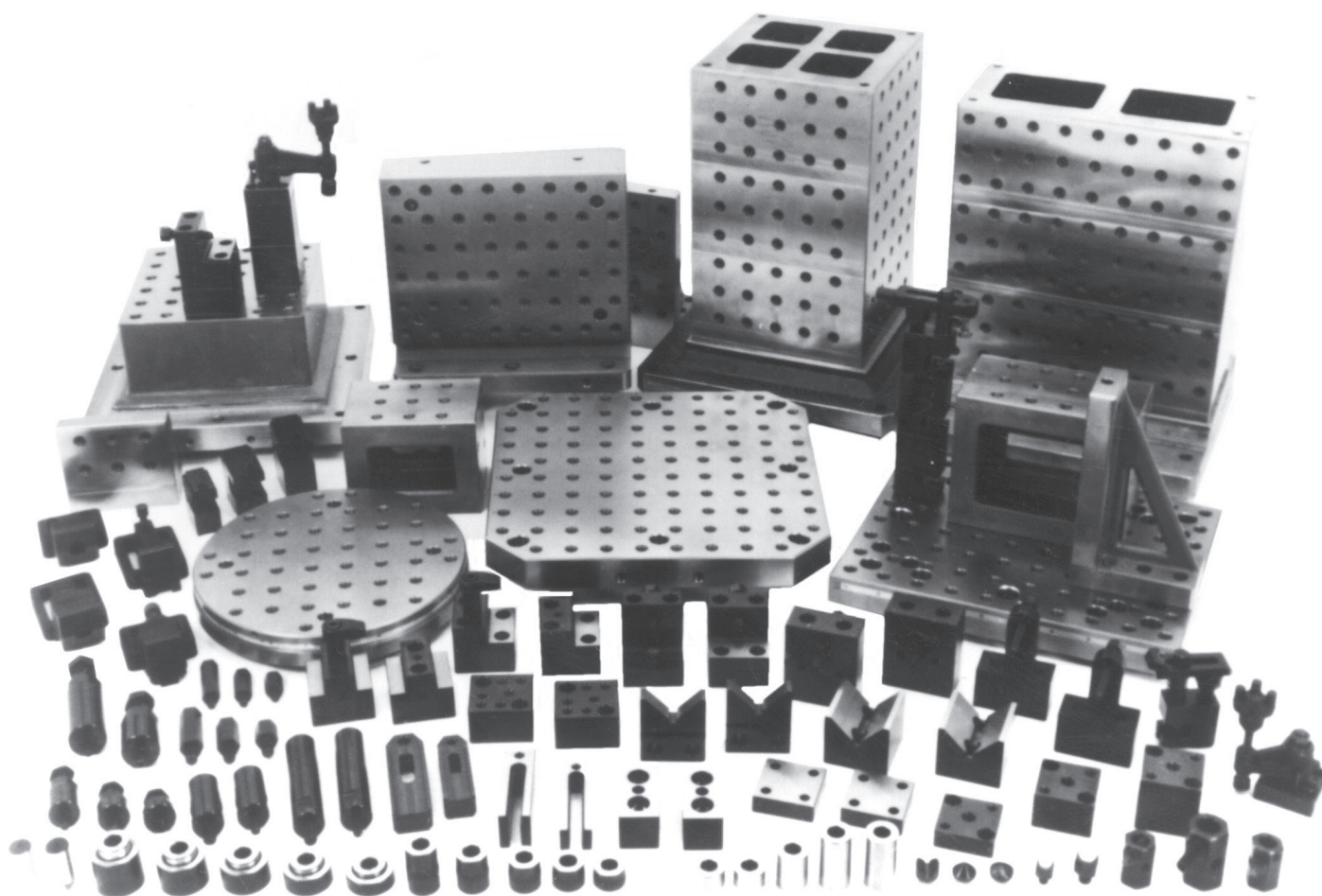

WHAT EXACTLY IS MODULAR FIXTURING?

In many ways modular fixturing is just like permanent fixturing, except for a few key differences. First, modular fixtures can be assembled entirely from reusable off-the-shelf components, without machining. Next, many modular components are adjustable and universal. Finally, specially designed tooling plates and blocks, with a standard grid pattern, are the foundation of a good modular system.

A VALUABLE TOOL FOR EVERY MACHINE SHOP:

Most metal-machining manufacturers have good applications for temporary fixturing every day! The leadtime and expense required to build a permanent fixture are often difficult to justify. This is especially true when production runs are small and do not repeat on a regular basis. General-purpose workholders — such as vises, chucks, and table mounted clamps — can be ready for production on short notice, but they are primarily suited for short runs of basic parts. Fortunately, there is now another alternative: modular fixturing. When a company adds modular fixturing to its options, even job-shop-type production can benefit from quality fixturing.

INTRODUCTION

GOOD APPLICATIONS FOR MODULAR FIXTURING:

Modular fixturing is an ideal answer to many workholding problems. One-time jobs, found especially in job shops, are ideal for modular fixturing; with modular fixturing, a workholder can be economically built even for a one-part run. Jobs that do not repeat on a regular basis are well suited to modular fixturing; modular fixturing permits rapid setup of short-notice production runs. Modular fixturing is also ideal for prototype parts; since prototypes are often changed or redesigned, the cost of building a permanent fixture for each new variation would be prohibitive. Replacement parts are another perfect application; modular fixturing allows a company to respond to orders as they are received, instead of shipping parts from an inventory. Trial fixturing is also an excellent application; modular workholders allow a designer to fine tune tooling ideas before a final production workholder is built. Finally, modular fixturing is valuable while permanent fixtures are built or repaired.

WIDE SELECTION OF TOOLING PLATES & BLOCKS:

Tooling plates and blocks are the main structural elements of any modular-fixturing system. The type, style, and number of plates and blocks available determine the variety of fixtures that can be built, and also the number of machine tools that can be used.

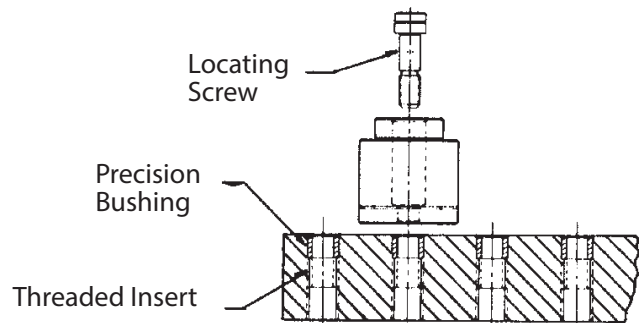
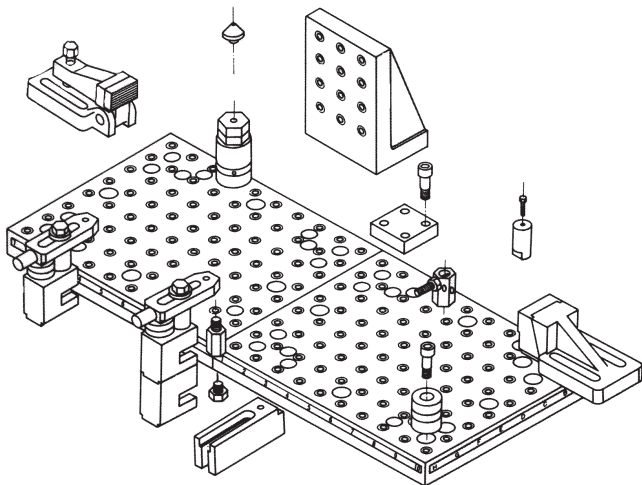

MULTIPURPOSE GRID HOLES OFFER MAXIMUM FLEXIBILITY:

Grid-pattern modular-fixturing systems come in two styles: those with alternating dowel holes and tapped holes and those with multipurpose holes. The alternating-hole style does not offer as many advantages as the Carr Lane Manufacturing multipurpose-hole style. Multipurpose holes have both an alignment bushing and threaded insert in the same hole. This arrangement permits each hole to serve as an alignment hole, mounting hole, or both. Multipurpose holes are laid out in a standard 1" or 2" grid pattern (depending on the size) to allow the maximum number of mounting locations.

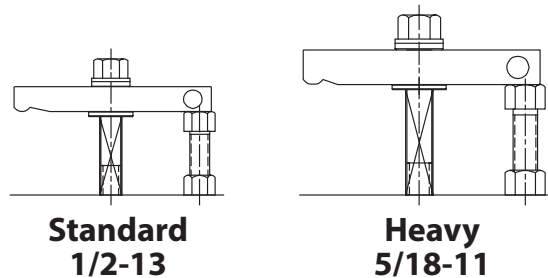

CHOICE OF TWO SYSTEM SIZES:

A good modular-fixturing system needs to accommodate a wide range of workpiece sizes. Only Carr Lane Manufacturing offers a full line of modular components in three system sizes. As a comparison to choose the proper system size, the table below shows typical clamping force exerted by clamp straps in each size (2-to-1 lever ratio).

SIZE	STUD SIZE	RECOMMENDED TORQUE (FT-LBS)	CLAMPING FORCE (LBS)
STANDARD	1/2-13	38	2300
HEAVY	5/8-11	77	3700

GRID HOLES VS. EARLIER T-SLOT SYSTEMS:

The two primary forms of modular systems available today are those with grid-pattern holes and earlier types with T slots to mount components. Grid holes offer many advantages over T slots. Modular systems with grid holes have greater positional accuracy and strength than those with T slots. T-slot systems permit movement along the slot, so nothing but friction holds components in place. Wherever T slots cross each other, a weak point exists.

MODULAR TOOLING PLATES & BLOCKS

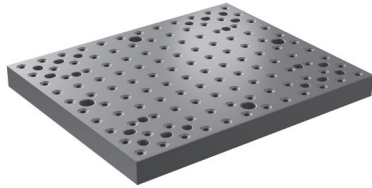

p. 411



Square Pallet
p. 412

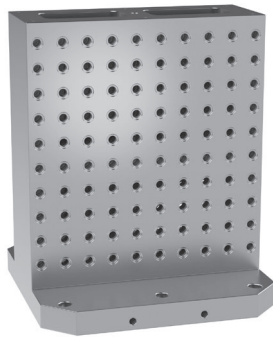

Two-Sided Blocks
p. 413

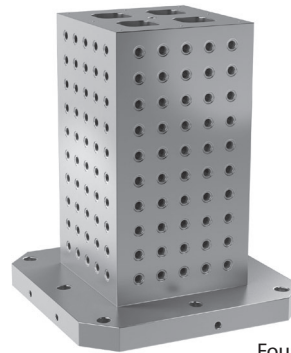

Four-Sided
Blocks
p. 414

MODULAR MOUNTING ACCESSORIES



Locating Screws
and Bushings
p. 415



Socket-Head
Cap Screws
p. 415



Hex-Head Cap
Screws
p. 415



Locating
Gages
p. 416



Locating
Pins
p. 416



Protection
Plugs
p. 416

PICTORIAL INDEX

MODULAR SUPPORTS & LOCATORS



Support
Cylinders
p. 417



Support
Cylinders
p. 418



Screw Rest Pads
p. 419

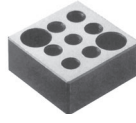

Support Riser
Blocks
p. 419



Extension Supports
p. 420



Stop-Spring-Button
Adaptors
p. 434



Horizontal V Blocks
p. 422



Vertical V Blocks
p. 423



Height Shims
p. 423



Manual Work Supports
p. 424



Knurled Screw Jacks
p. 424



Screw Jacks
p. 425



Torque Screw Jacks
p. 425

MODULAR CLAMPS



Forged Adjustable Clamps
p. 426



Slotted-Heel Clamp Straps
p. 427



Double-End Clamp Straps
p. 441

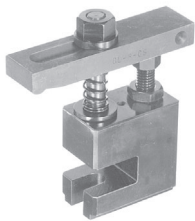

High-Rise Clamps
p. 429



Hook Clamps
p. 431



Up-Thrust Clamps
p. 434

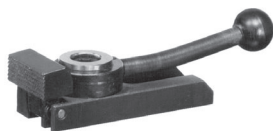

Cam Edge Clamps
p. 434



Serrated Adjustable
Clamps
p. 435



Pivoting Edge Clamps
p. 457

TECHNICAL INFORMATION

MULTIPURPOSE HOLES

Standard

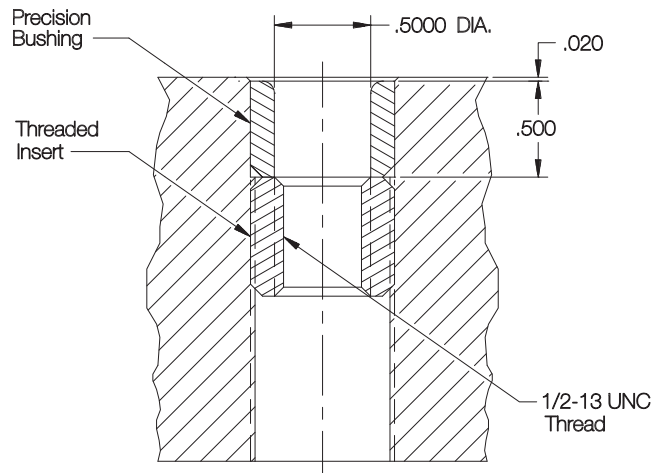
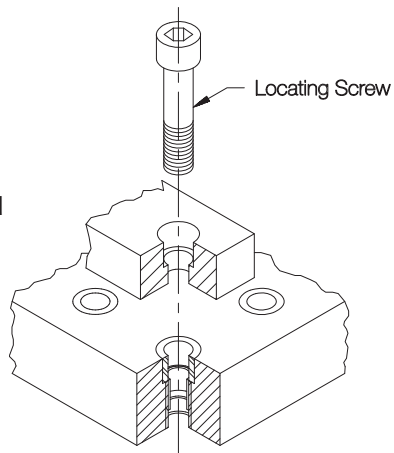

Heavy

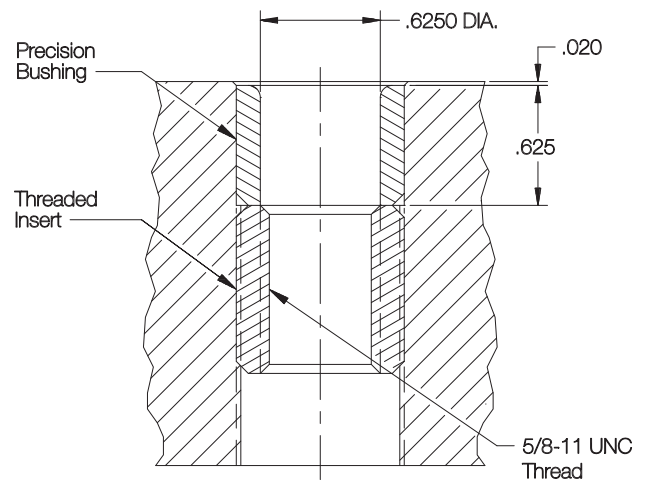
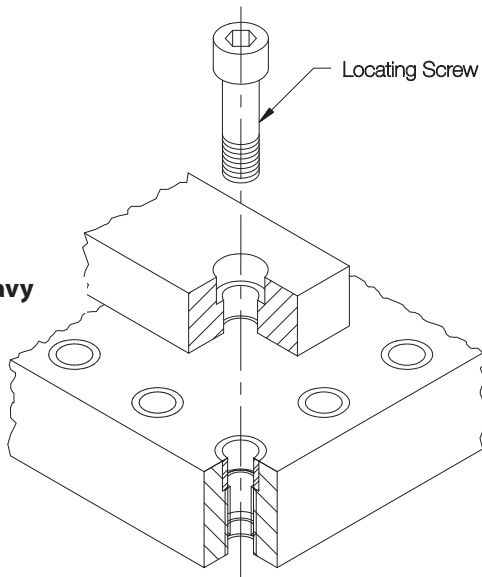

Every multipurpose hole on a tooling plate or block has a precision alignment bushing on top, with a threaded insert below it. Multipurpose holes will accept Locating Screws, Socket-Head Cap Screws, studs, and many other threaded components. The proper mounting screw for each component is listed in its table of dimensions. Locating Screws are used to locate and fasten at the same time.

TECHNICAL INFORMATION

GRID ADDRESS SYSTEM

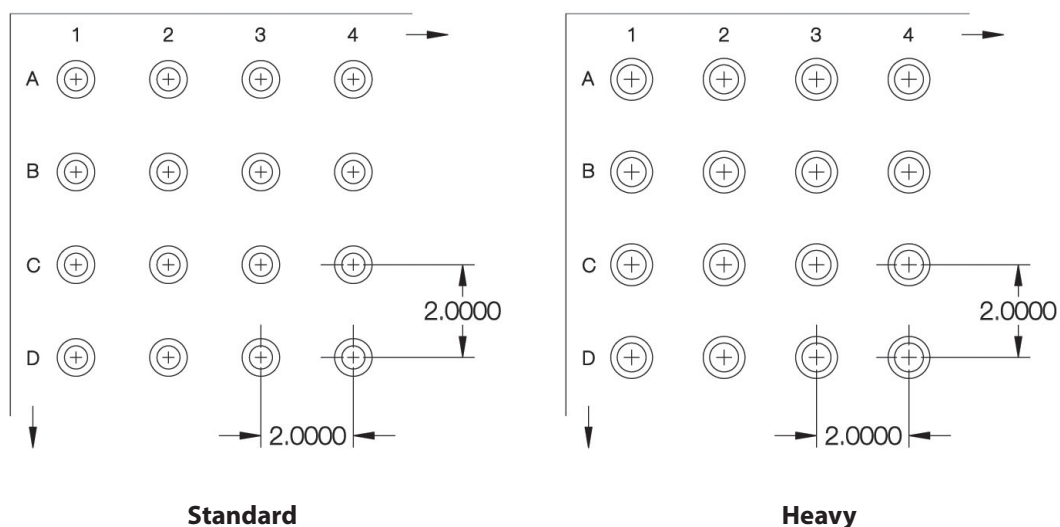

The grid pattern of multipurpose holes on every tooling plate and tooling block face is labelled with letters in one direction and numbers in the perpendicular direction. Tooling-block faces are numbered (counterclockwise) with Roman numerals. This allows recording the mounting-hole location of each component (e.g., A2, B3, D7, etc.) as part of permanent documentation. Multipurpose holes are spaced within $\pm.0008$ inches of true position on all tooling plates and blocks.

CUSTOM TOOLING PLATES

To build your own custom tooling plates with multipurpose mounting holes, we offer precision bushings and threaded inserts separately. See hole locations and tolerances above (holes must be jig bored), and (INFO+) page 420 for proper counterbore depth to install bushings. The threaded insert's locking keys can be driven down by the bushing as it is pressed into the tooling plate.

10



Precision Bushing



Key Insert

PRECISION BUSHINGS

SIZE	PART NO.	ID	OD	LENGTH
STANDARD	CL-MF40-0101-02	.5006/.5013	.8122/.8119	.500
HEAVY	CL-MF50-0101-02	.6256/.6263	.9060/.9056	.625

KEY INSERTS

SIZE	PART NO.	ID	OD	LENGTH
STANDARD	CL-1213-KS	1/2-13	3/4-16	5/8
HEAVY	CL-5811-KS	5/8-11	7/8-14	7/8

MOUNTING TOOLING PLATES ON T-SLOTTED TABLES

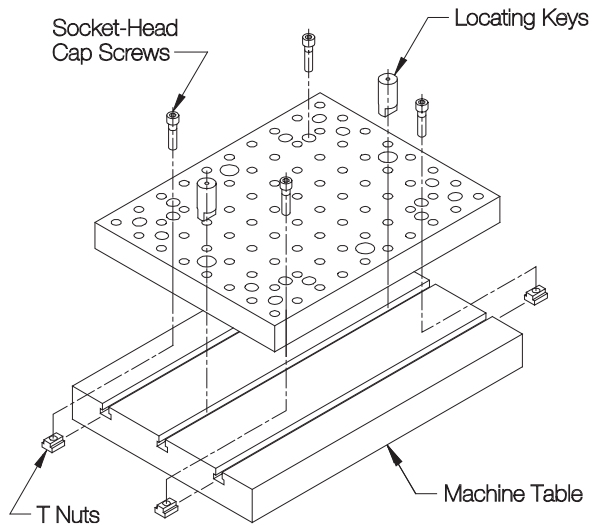

Standard and Heavy

Standard and heavy Rectangular Tooling Plates are accurately located on T-slotted tables using two Locating Keys (**INFO+** page 257) in the center table slot. These plates are fastened to the machine table using four or six Socket-Head Cap Screws (**INFO+** page 428) and T Nuts (**INFO+** page 320). Swivel Hoist Rings are recommended for lifting large tooling plates (**INFO+** page 75).

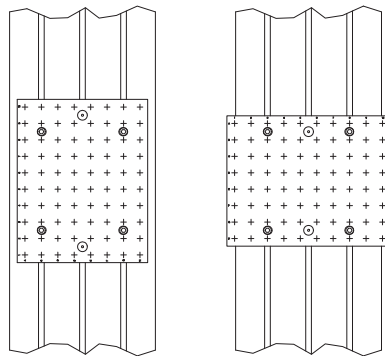

Two sets of Locating-Key holes allow mounting plates either lengthwise or widthwise on a machine table.

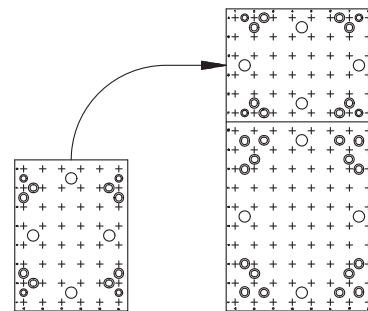

The length of each Rectangular Tooling Plate is the same as the width of the next-larger size, allowing many possible combinations by turning plates 90°.

TECHNICAL INFORMATION

MOUNTING TOOLING PLATES & BLOCKS ON PALLETS

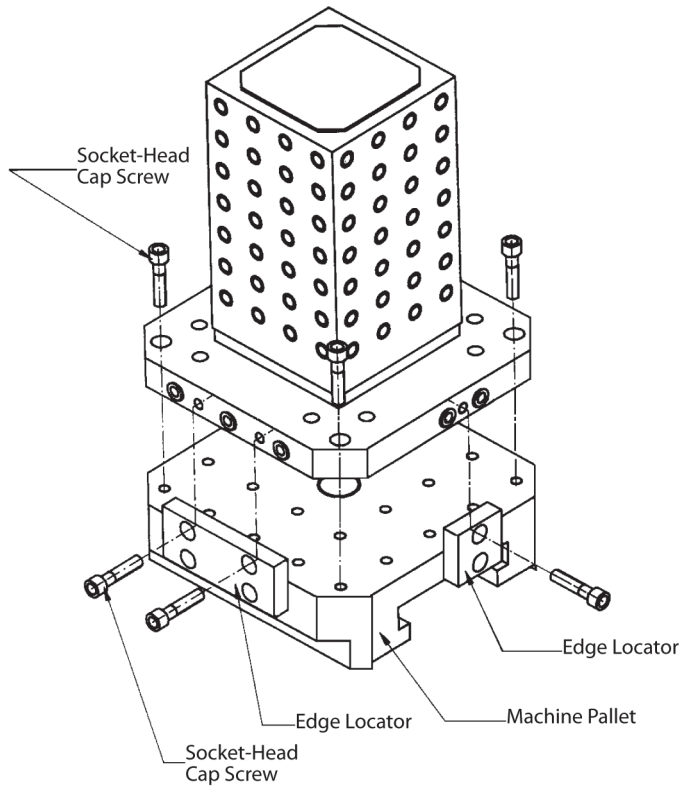

JIS Mounting

JIS-type mounting is the most common way to mount tooling plates and blocks on a machining-center pallet. Here the plate or block is located from two precisely ground reference edges at 90° to each other. The plate or block is pulled against the pallet's edge locators using three Socket-Head Cap Screws and also fastened down with four to eight Socket-Head Cap Screws, depending on the size. Swivel Hoist Rings are recommended for lifting tooling blocks and large tooling plates.

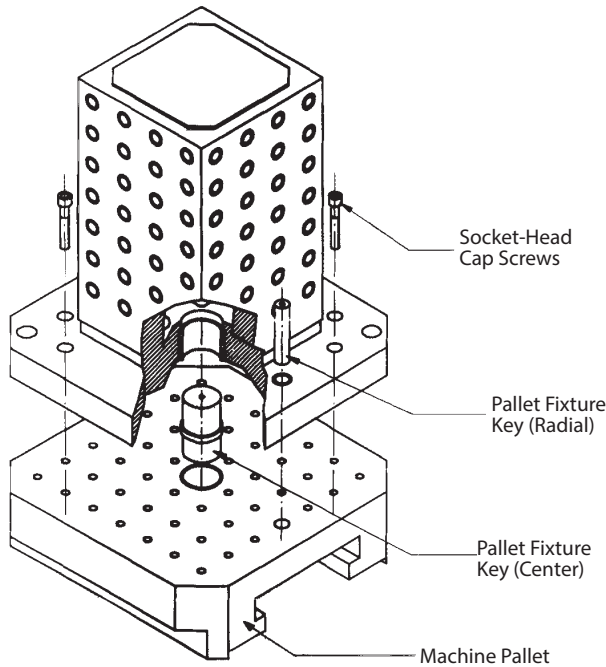

DIN Mounting

Most of our modular tooling plates and blocks also incorporate DIN-mounting capability. Here the plate or block is located using a center hole, and oriented using a radial hole. Two Pallet Fixture Keys, a center pin and a radial pin, are required. The plate or block is fastened down with four to eight Socket-Head Cap Screws, depending on the size.

PALLET SIZE	PALLET CENTER-HOLE DIA	PALLET RADIAL-HOLE DIA	DISTANCE BETWEEN CENTER AND RADIAL HOLES
320mm	50mm	20mm	100mm
400mm			150mm
500mm			200mm
630mm	25mm	25mm	200mm
800mm			300mm

RECTANGULAR TOOLING PLATES

GRAY CAST IRON, ASTM CLASS 45

16x20

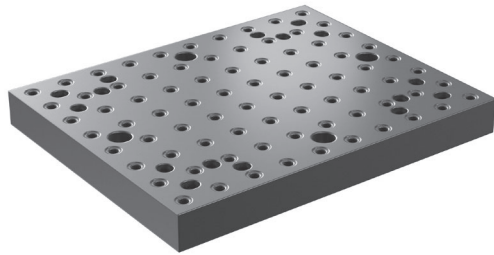

Standard 1/2"

20x24

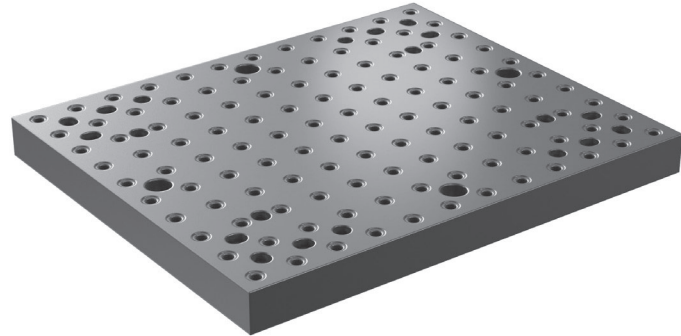

Standard 1/2"

Ideal tooling plate for most milling machines. Finish ground to tight tolerances, with all multipurpose holes located within .0008 inches of true position. Available in a full range of standard fixture sizes, with mounting holes to fit almost any inch or metric slot spacing. Plates can be accurately connected to create many length and width combinations.

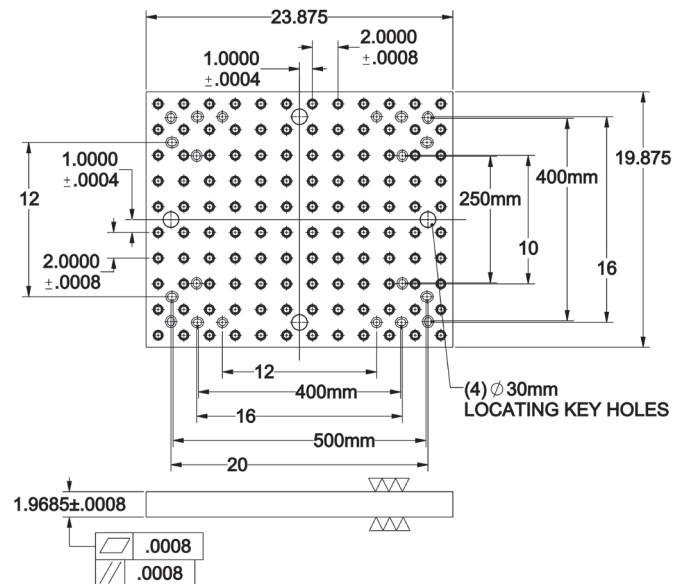
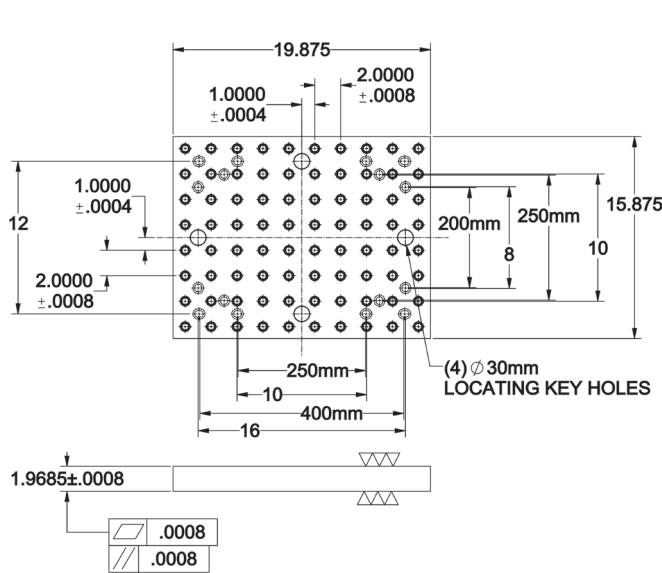

10

SIZE	PART NO.	MULTIPURPOSE HOLES				PLATE WIDTH		PLATE LENGTH		MOUNTING SCREWS	NO. OF MOUNTING SCREWS REQUIRED	APPROX WEIGHT (LBS)
		THREAD	ID	SPACING	PATTERN	NOMINAL	ACTUAL	NOMINAL	ACTUAL			
STANDARD	CL-1620-RTPM-40	1/2-13	.5000	2.0000	8x10	16	15.875	20	19.875	1/2-13 or M12	4	160
	CL-2024-RTPM-40				10x12	20	19.875	24	23.875			238

SQUARE PALLET TOOLING PLATES

GRAY CAST IRON, ASTM CLASS 45

400mm



Heavy 5/8"

500mm



Heavy 5/8"

Ideal tooling plate for horizontal-machining-center pallets. Finish machined to tight tolerances. Available in a full range of standard pallet sizes, with mounting holes to fit almost any inch or metric slot spacing. JIS mounting from two reference edges provides accurate location. Also available as blanks, without multipurpose holes.

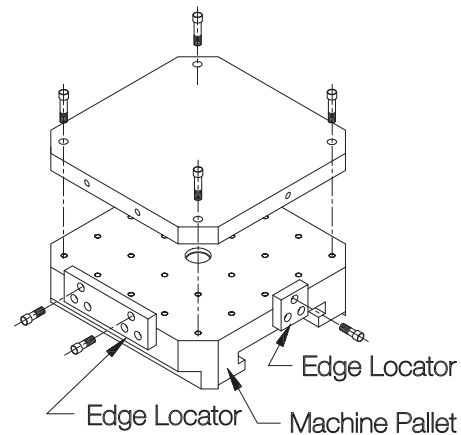

JIS Mounting

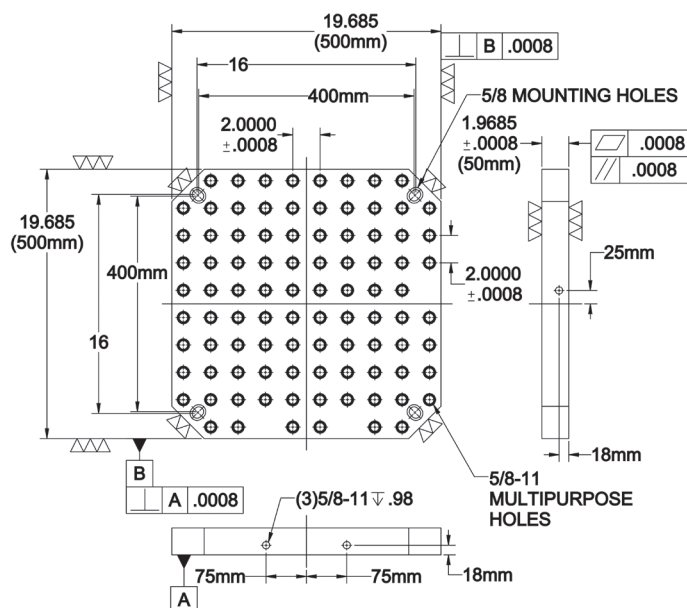
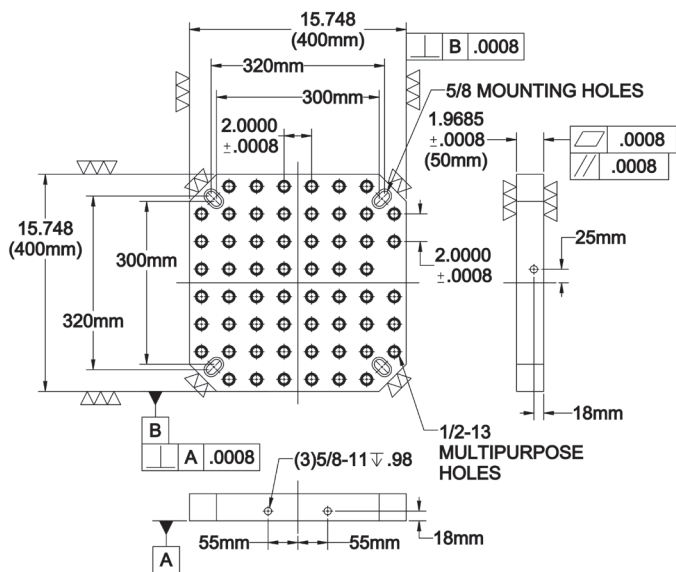

SIZE	PART NO.	MULTIPURPOSE HOLES				PALLET SIZE	PLATE THICKNESS	APPROX. WEIGHT (LBS)
		THREAD	ID	SPACING	PATTERN			
HEAVY	CL-400-PTPM-50	5/8-11	.6250	2.0000	10x10	400mm	50mm	175
	CL-500-PTPM-50				12x12	500mm		280

TWO-SIDED TOOLING BLOCKS

GRAY CAST IRON, ASTM CLASS 45

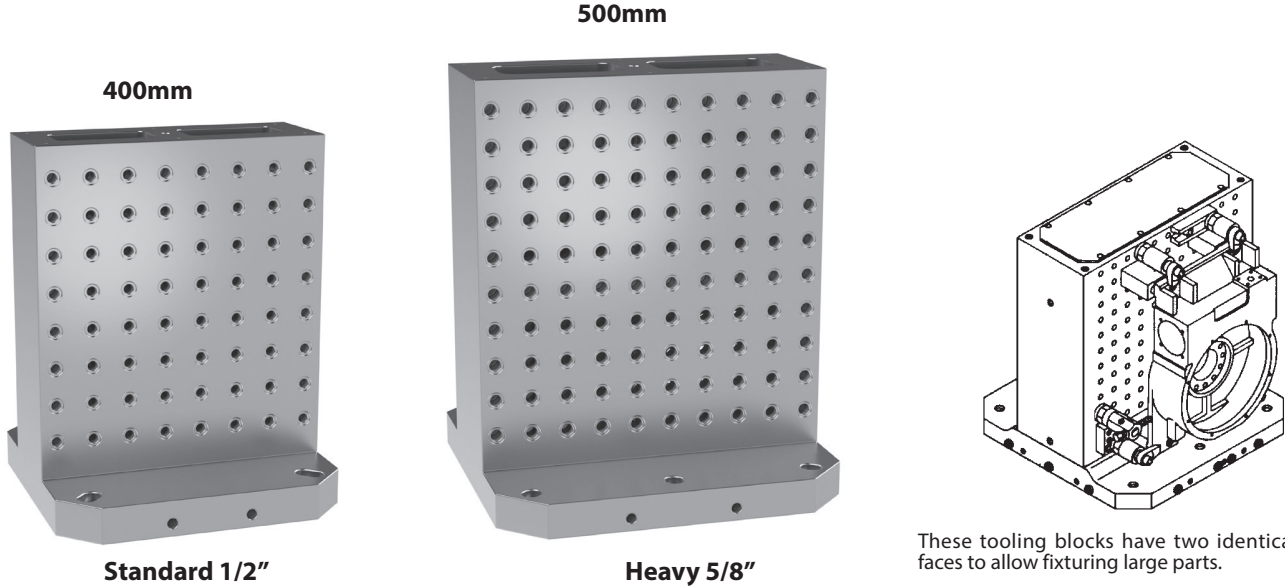

These tooling blocks have two identical wide faces to allow fixturing large parts.

Precision tooling block for horizontal-machining-center pallets. Both faces are accurately finish machined to tight tolerances, and qualified to the base. All multipurpose holes are spaced within .0008 inches of true position (.0004 for mini). One-piece cast construction provides superior accuracy, dimensional stability, and vibration dampening. Available in a full range of standard pallet sizes, with mounting holes to fit almost any inch or metric slot spacing. Dual mounting capability allows both JIS mounting (locating from two reference edges) and DIN mounting (locating from center and radial holes) with excellent accuracy.

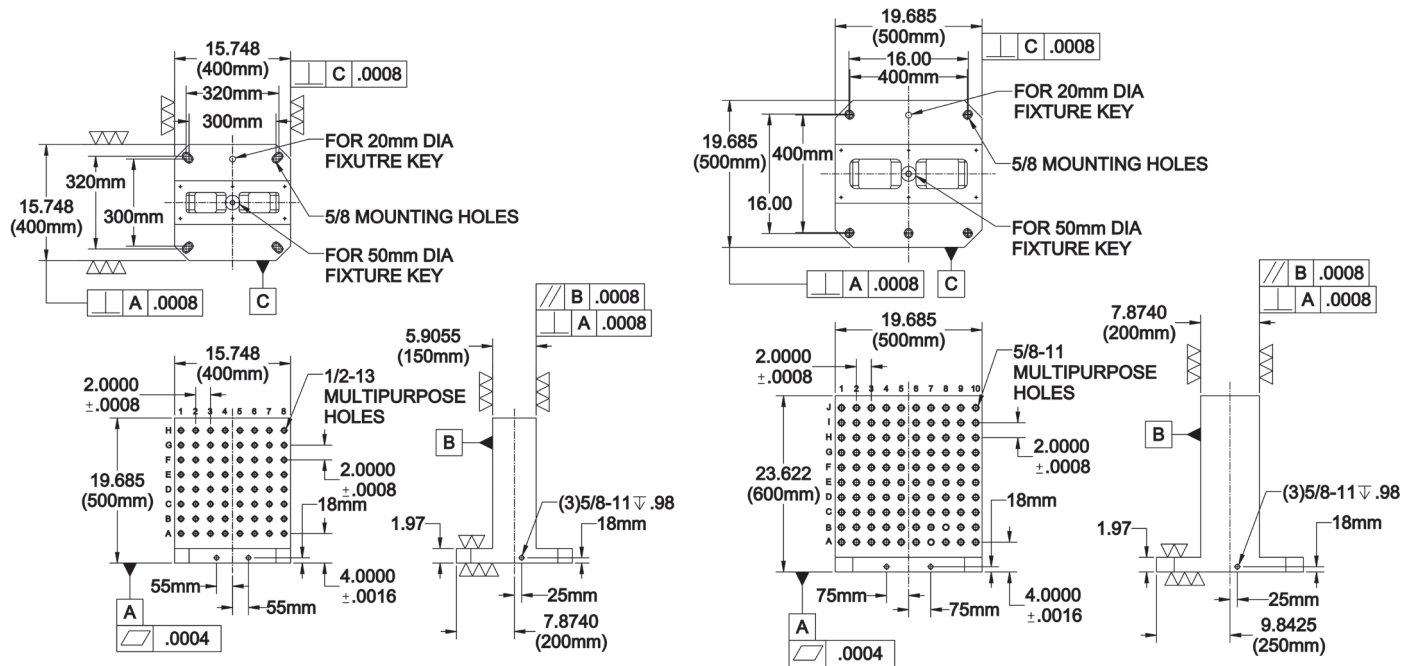

SIZE	PART NO.	MULTIPURPOSE HOLES			PALLET SIZE	APPROX. WEIGHT (LBS)
		THREAD	ID	SPACING PATTERN		
STANDARD	CL-400400500-TTBM-40	1/2-13	.5000	2.0000 8x8	400mm	340
HEAVY	CL-500500600-TTBM-50	5/8-11	.6250	2.0000 10x10	500mm	516

FOUR-SIDED TOOLING BLOCKS

GRAY CAST IRON, ASTM CLASS 45

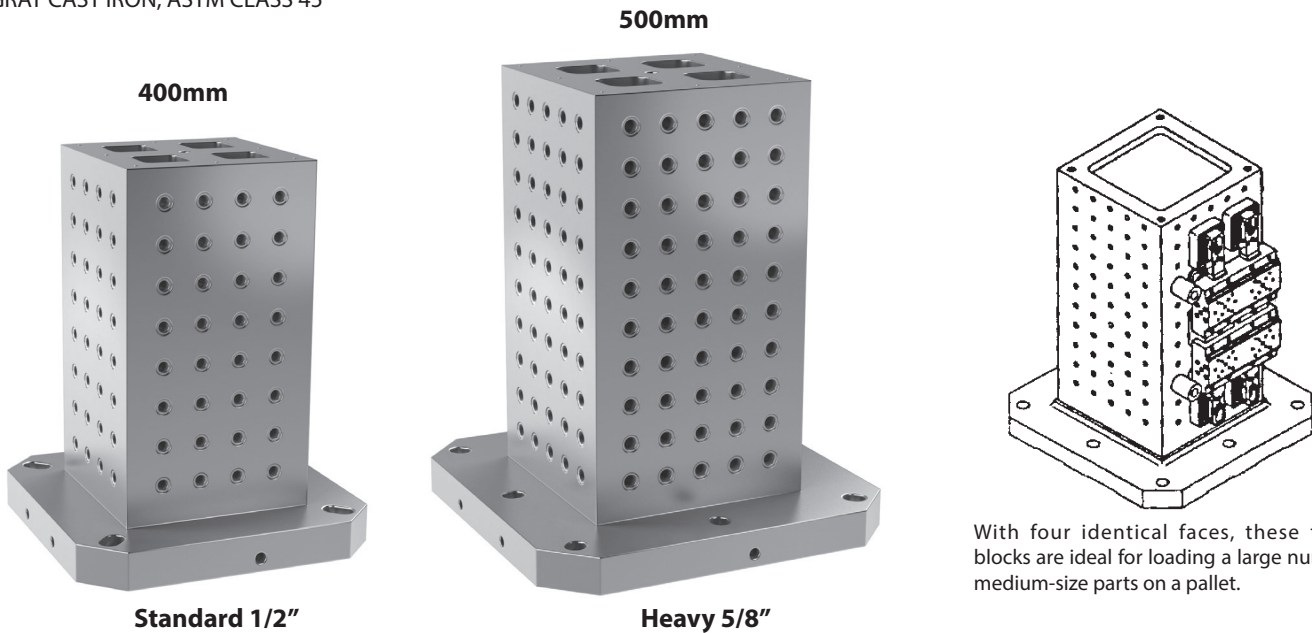

With four identical faces, these tooling blocks are ideal for loading a large number of medium-size parts on a pallet.

Precision four-sided tooling block for horizontal-machining-center pallets. All four faces are accurately finish machined to tight tolerances, and qualified to the base. All multipurpose holes are spaced within .0008 inches of true position (.0004 for mini). One-piece cast construction provides superior accuracy, dimensional stability, and vibration dampening. Available in a full range of standard pallet sizes, with mounting holes to fit almost any inch or metric slot spacing. Dual mounting capability allows both JIS mounting (locating from two reference edges) and DIN mounting (locating from center and radial holes) with excellent accuracy. Also available as blanks, without multipurpose holes.

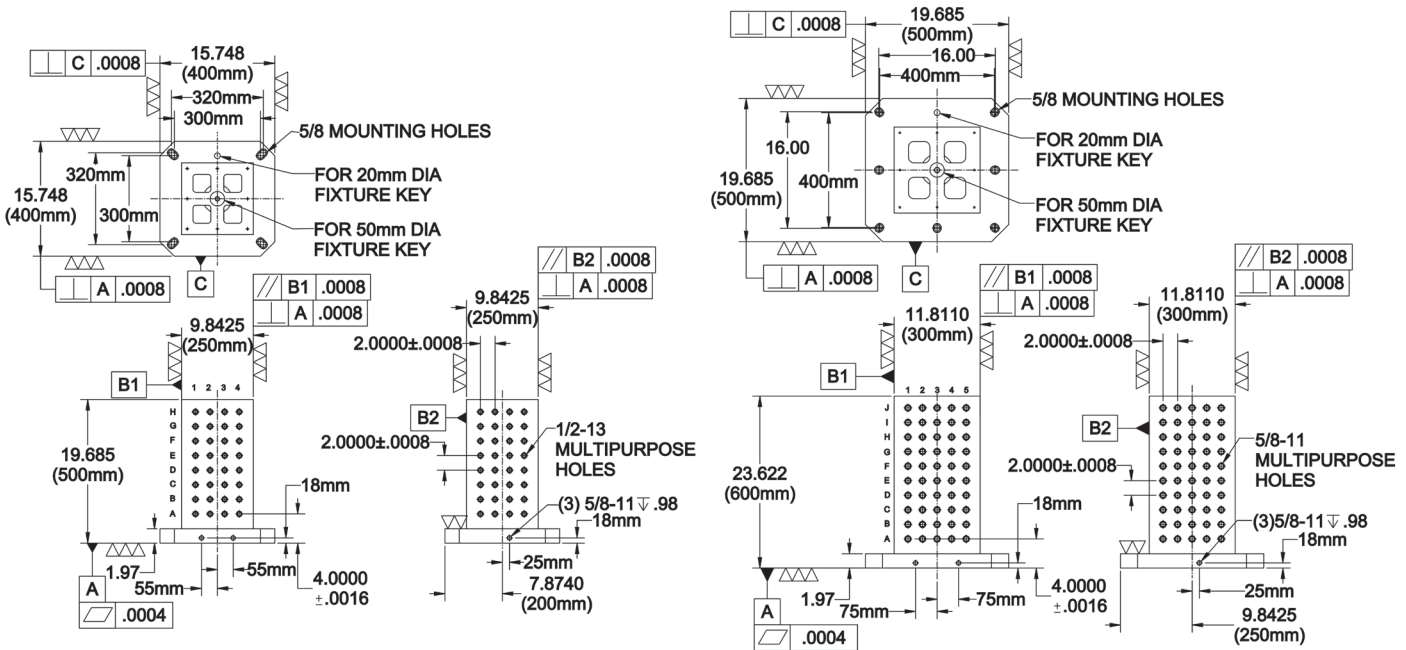

SIZE	PART NO.	MULTIPURPOSE HOLES				PALLET SIZE	APPROX. WEIGHT (LBS)
		THREAD	ID	SPACING	PATTERN		
STANDARD	CL-400250500-FTBM-40	1/2-13	.5000	2.0000	4x8	400mm	375
HEAVY	CL-500300600-FTBM-50	5/8-11	.6250	2.0000	5x10	500mm	584

LOCATING SCREWS

4130 STEEL, HEAT TREATED RC 33-39, BLACK OXIDE FINISH

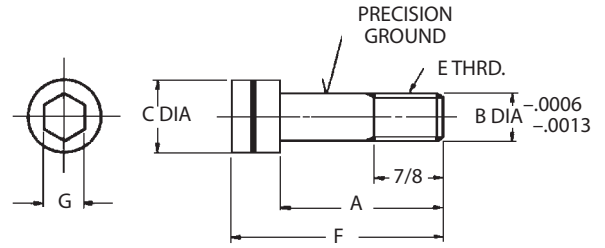
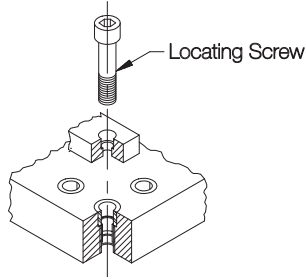
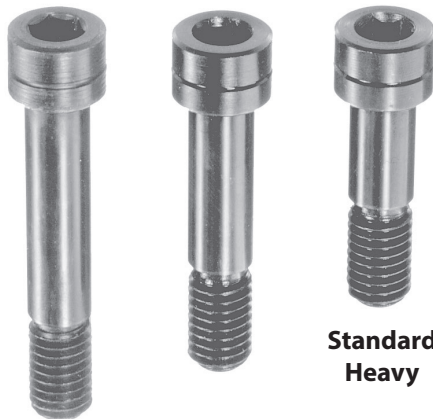

Locating Screws are used to mount all locators in multipurpose grid holes. These specially designed, precision shoulder screws accurately locate and fasten at the same time.

Standard
Heavy

SIZE	PART NO.	A	B DIA	C DIA	E	F	G
STANDARD	CL-MF40-4301	1-3/4	.5000	3/4	1/2-13	2-1/4	3/8
	CL-MF40-4302	2-1/4				2-3/4	
	CL-MF40-4303	2-3/4				3-1/4	
HEAVY	CL-MF50-4301	2				2-5/8	1/2
	CL-MF50-4302	2-1/2	.6250	15/16	5/8-11	3-1/8	
	CL-MF50-4303	3				3-5/8	

SOCKET-HEAD CAP SCREWS

GRADE 8, BLACK OXIDE FINISH



Standard
Heavy

Socket-Head Cap Screws (grade 8) are used for fastening components whenever precise location is not needed. Metric sizes are used to fasten plates and blocks to machine pallets.

INCH

PART NO.	THREAD SIZE	LENGTH UNDER HEAD
CL-6-32x.50-SHCS	#6-32	.50
CL-10-32x.50-SHCS	#10-32	.50
CL-1/4-20x.75-SHCS	1/4-20	.75
CL-1/2-13x1.00-SHCS	1/2-13	1.00
CL-1/2-13x1.25-SHCS		1.25
CL-1/2-13x1.50-SHCS		1.50
CL-1/2-13x1.75-SHCS		1.75
CL-1/2-13x2.00-SHCS		2.00
CL-1/2-13x2.25-SHCS		2.25
CL-1/2-13x2.75-SHCS		2.75
CL-1/2-13x4.50-SHCS		4.50
CL-5/8-11x1.00-SHCS		5/8-11
CL-5/8-11x1.25-SHCS	1.25	
CL-5/8-11x1.50-SHCS	1.50	
CL-5/8-11x2.00-SHCS	2.00	
CL-5/8-11x2.25-SHCS	2.25	
CL-5/8-11x2.50-SHCS	2.50	
CL-5/8-11x3.00-SHCS	3.00	
CL-5/8-11x5.00-SHCS	5.00	

METRIC

PART NO.	THREAD SIZE	LENGTH UNDER HEAD
CLM-16x40-SHCS	M16	1.57
CLM-16x50-SHCS		1.97
CLM-16x65-SHCS		2.56

HEX-HEAD CAP SCREWS

GRADE 8, BLACK OXIDE FINISH



Standard
Heavy

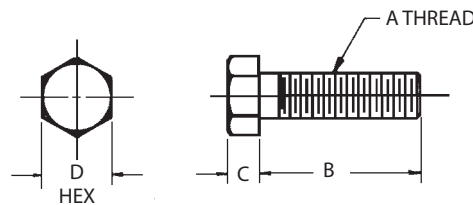

Mounting screws for high-rise clamps, where access to a socket-head screw is difficult.

SIZE	PART NO.	A	B	C	D
STANDARD	CL-MF40-4311	1/2-13	1.75	5/16	3/4
	CL-MF40-4312		2.75		
	CL-MF0-4313		3.00		
HEAVY	CL-MF50-4311	5/8-11	1.75	25/64	15/16
	CL-MF50-4312		2.75		
	CL-MF50-4313		3.00		

LOCATING GAGES

1045 STEEL, BLACK OXIDE FINISH



Standard Heavy

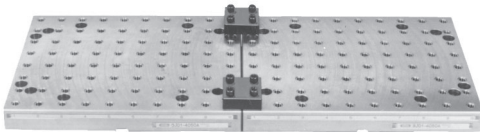

Use when connecting two tooling plates, to hold tolerances. Remove after fastening plates to machine.

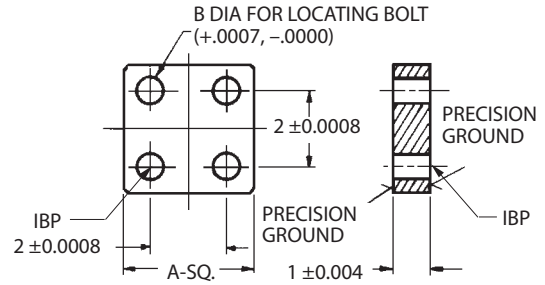

SIZE	PART NO.	A	B DIA	LOCATING SCREW (4 REQD)
STANDARD	CL-MF40-4001	3-1/8	.5000	CL-MF40-4302
HEAVY	CL-MF50-4001	3-3/8	.6250	CL-MF50-4302

LOCATING PINS

1144 STEEL, HEAT TREATED RC 50-55, BLACK OXIDE FINISH



Round



Diamond

Round and Diamond Locating Pins are used together to align Quick-Change Tooling Plates or vises on a modular plate or block.

Standard Heavy

ROUND

SIZE	PART NO.	HEAD DIA	SHANK DIA
STANDARD	CL-MF40-4501	.6250	.5000
HEAVY	CL-MF50-4501	.6250	.6250

DIAMOND

SIZE	PART NO.	HEAD DIA	SHANK DIA
STANDARD	CL-MF40-4601	.6250	.5000
HEAVY	CL-MF50-4601	.6250	.6250

10

PROTECTION PLUGS

PLASTIC



Standard Heavy

Durable screw-in plugs to keep dirt and chips out of holes that are not used for a particular setup.

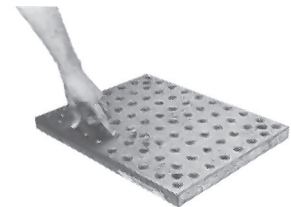

SIZE	PART NO.
STANDARD	CL-MF40-0001
HEAVY	CL-MF50-0001

SUPPORT CYLINDERS

1045 OR 1144 STEEL, HEAT TREATED, BLACK OXIDE FINISH



Standard Heavy

Extremely versatile precision locator that can be used either as a support or for side location. Ground on top, bottom, and outside diameter. Available in many support heights to match other types of height locators.

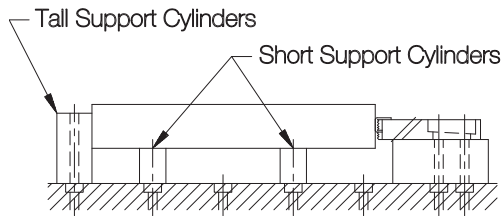
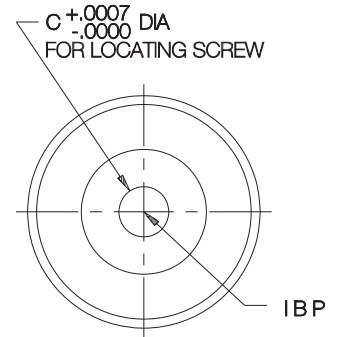

With the wide range of available heights, Support Cylinders can be used as both side locators and supports.

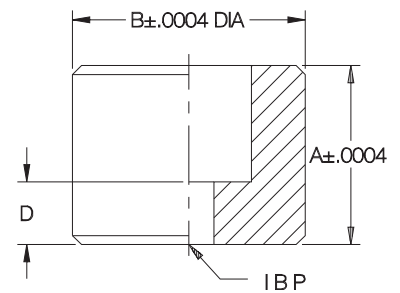

Standard Heavy

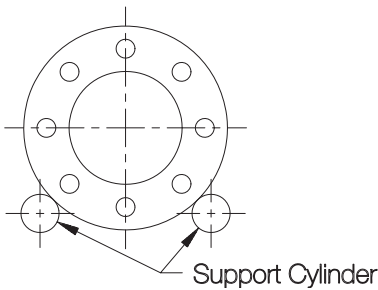

Two Support Cylinders can accurately locate a large diameter, similar to using a V Block.

SIZE	PART NO.	A	B DIA	C DIA	D	LOCATING SCREW (1 REQD)
STANDARD	CL-MF40-3101	1.0000	1.6250	.5000	7/16	CL-MF40-4301
	CL-MF40-3113	1.5000				
	CL-MF40-3102	2.0000				
	CL-MF40-3103	3.0000				
HEAVY	CL-MF50-3113	1.5000	2.0000	.6250	9/16	CL-MF50-4301
	CL-MF50-3101	2.0000				CL-MF50-4302
	CL-MF50-3102	3.0000			1-1/16	
	CL-MF50-3103	4.0000				

SHOULDER SUPPORT CYLINDERS

1045 OR 1144 STEEL, HEAT TREATED, BLACK OXIDE FINISH



Standard
Heavy

Precision edge locator with a ground shoulder for simultaneous horizontal and vertical location. Available in many support heights to match other types of height locators. The standard (1/2") and heavy (5/8") versions are fastened with a Locating Screw (order separately).

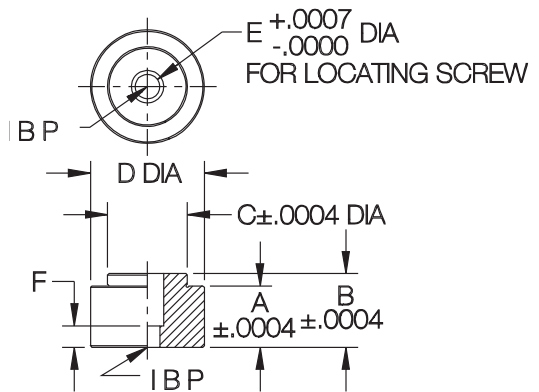

Standard and Heavy

10

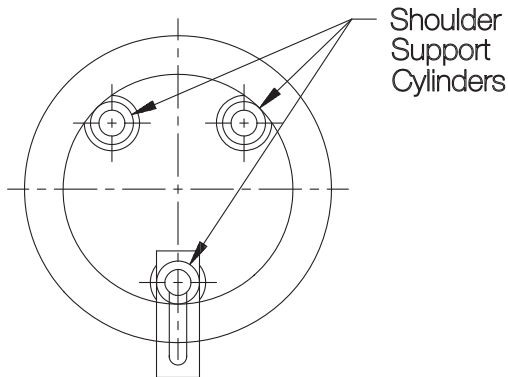

Shoulder Support Cylinders can be used to locate from internal edges, as well as external edges. Shown here, three of them locate a large bored diameter, one mounted on an Extension Support.

SIZE	PART NO.	A	B	C DIA	D DIA	E DIA	F	LOCATING SCREW (1 REQD)
STANDARD	CL-MF40-3201	.7500	1.0000	1.6250	2-5/16	.5000	7/16	CL-MF40-4301
	CL-MF40-3202	1.0000	1.2500					
HEAVY	CL-MF50-3201	1.0000	1.2500	2.0000	2-7/8	.6250	9/16	CL-MF50-4301
	CL-MF50-3203	1.5000	2.0000					
	CL-MF50-3204	2.0000	2.5000					

SCREW REST PADS

12L14 STEEL, CARBURIZED-HARDENED, BLACK OXIDE FINISH



**Mini
Standard
Heavy**

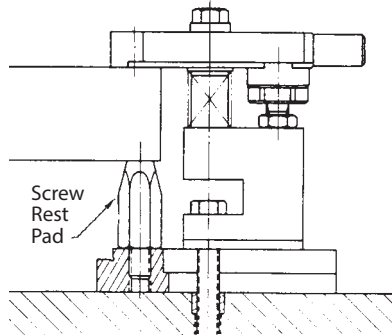

Precision height locator with a small contact area. Available in a wide range of heights, including very short sizes. This support can be installed in either a plain tapped hole or a multipurpose hole. **INFO+**: For metric sizes, see page 225.

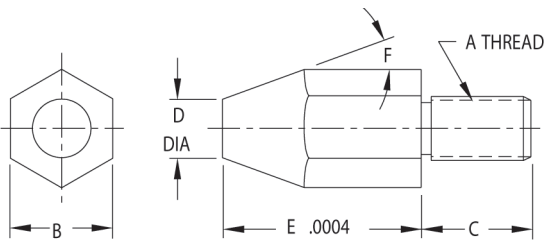

SIZE	PART NO.	A	B	C	D DIA	E	F
MINI	CL-MF25-4801	5/16-18	3/4	5/8	5/16	.2500	75°
	CL-MF25-4802					.3750	60°
	CL-MF25-4803					.5000	35°
	CL-MF25-4804					.7500	25°
	CL-MF25-4805					1.0000	20°
	CL-MF25-4806					1.2500	15°
	CL-MF25-4807					1.5000	
STANDARD	CL-MF40-4801	1/2-13	7/8	15/16	1/2	.2500	75°
	CL-MF40-4802					.3750	60°
	CL-MF40-4803					.5000	35°
	CL-MF40-4804					.7500	25°
	CL-MF40-4805					1.0000	20°
	CL-MF40-4806					1.2500	15°
	CL-MF40-4807					1.5000	
	CL-MF40-4808					2.0000	
HEAVY	CL-MF50-4801	5/8-11	1	1-1/4	5/8	.2500	75°
	CL-MF50-4802					.3750	60°
	CL-MF50-4803					.5000	35°
	CL-MF50-4804					.7500	25°
	CL-MF50-4805					1.0000	20°
	CL-MF50-4806					1.2500	15°
	CL-MF50-4807					1.5000	
	CL-MF50-4808					2.0000	

SUPPORT RISER BLOCKS

1045 STEEL, BLACK OXIDE FINISH

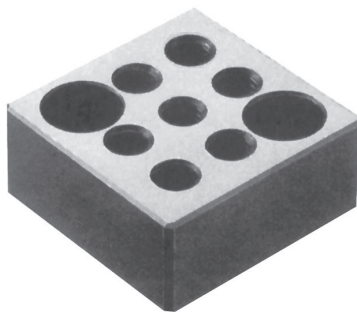

**Standard
Heavy**

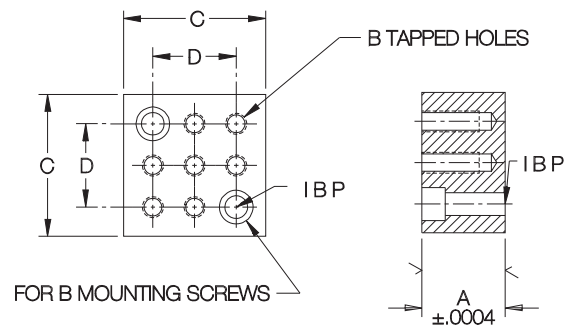

Stackable block with precision ground top and bottom surfaces for accurate height location. Ideal for raising supports up to a workpiece. A choice of seven tapped holes allows mounting the support at any position between grid points.

SIZE	PART NO.	A	B	C	D	SOCKET-HEAD CAP SCREWS (2 REQD)
STANDARD	CL-MF40-1411	1.0000	1/2-13	3-3/8	2	CL-1/2-13x1.75-SHCS
HEAVY	CL-MF50-1413	1.5000	5/8-11	3-3/8	2	CL-5/8-11x2.25-SHCS

EXTENSION SUPPORTS

1045 STEEL, HEAT TREATED, BLACK OXIDE FINISH

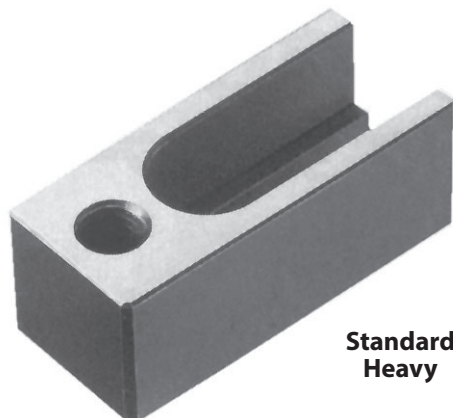

**Standard
Heavy**

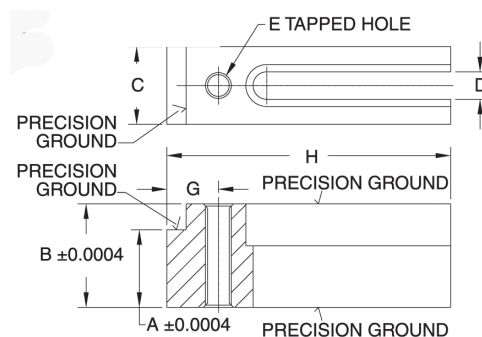

Extension Supports have a precision ground top and bottom surface for accurate height location. Available in a support height to match other types of height locators. The tapped hole is ideal for positioning components between grid points.

SIZE	PART NO.	A	B	C	D	E	F	G	H	SOCKET-HEAD CAP SCREW (1 REQD)
STANDARD	CL-MF40-3311	No step	1.0000	1-1/2	17/32	1/2-13	3/8	1	5-1/2	CL-1/2-13x1.50-SHCS
HEAVY	CL-MF50-3311	No step	1.5000	2	21/32	5/8-11	1/2	1-1/8	5-1/2	CL-5/8-11x2.00-SHCS

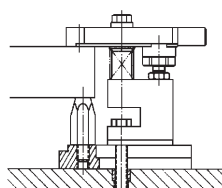

Screw Rest Pads (**INFO+** page 432) can be positioned anywhere between grid points when mounted on an Extension Support.

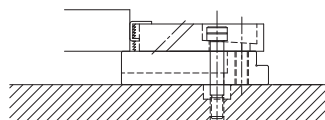

Extension Supports are a perfect height locator to mount underneath Serrated Edge Clamps (**INFO+** page 448).

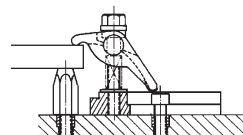

Forged Adjustable Clamps (**INFO+** page 438) can be placed anywhere between grid points when mounted in an Extension Support's tapped hole.

SPRING-STOP-BUTTON ADAPTORS

CARBON STEEL, HEAT TREATED, BLACK OXIDE FINISH

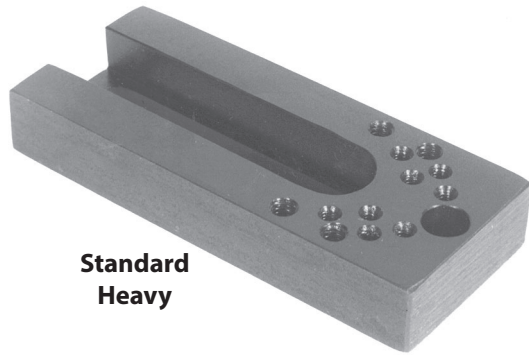

**Standard
Heavy**

Versatile adaptor for standard Spring Stop Buttons and Spring Locating Pins. Applies spring pressure to the workpiece to hold it against its locators. Fits three sizes of Spring Stop Buttons, both round and flat face, and two sizes of Spring Locating Pins.
Patent no. 4,832,325.

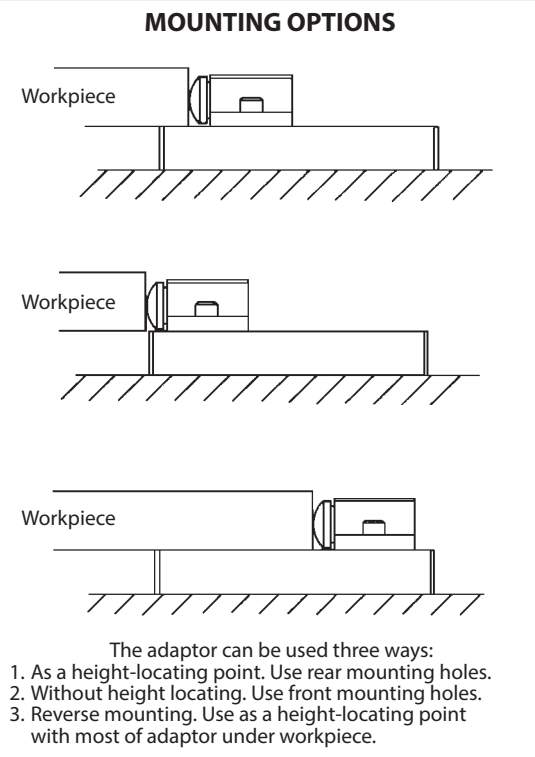
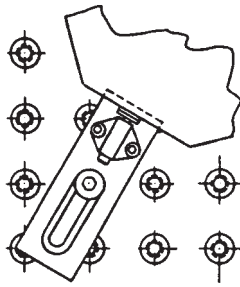

**Round-Face
Spring Stop Buttons**



**Flat-Face
Spring Stop Buttons**



**Spring
Locating Pins**

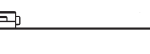

CL-10C-SSB

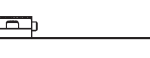
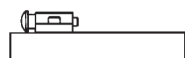

CL-20C-SSB

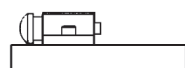

CL-30A-SSB

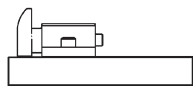

CL-30C-SSB



CL-7-SLP-1 Light
CL-7-SLP-2 Medium
CL-7-SLP-3 Heavy



CL-7A-SLP-1 Light
CL-7A-SLP-2 Medium
CL-7A-SLP-3 Heavy

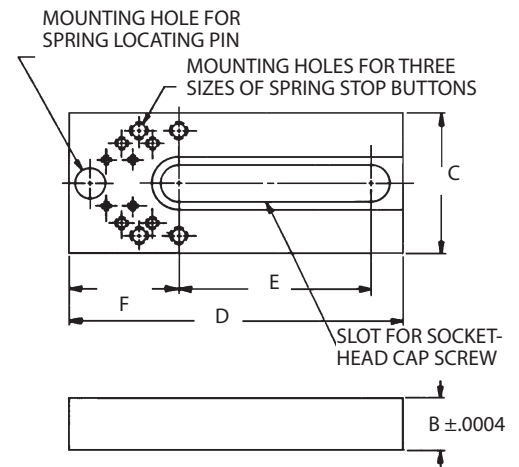

SIZE	PART NO.	FITS ROUND FACE STOP BUTTONS	FITS FLAT FACE STOP BUTTONS	FITS SPRING LOCATING PINS	B	C	D	E	F	SOCKET-HEAD CAP SCREW (1 REQD)	SOCKET-HEAD CAP SCREWS FOR SPRING STOP BUTTONS (2 REQD)		
											SMALL	MEDIUM	LARGE
STANDARD	CL-MF40-3902	CL-10A-SSB CL-20A-SSB CL-30A-SSB	CL-10C-SSB CL-20C-SSB CL-30C-SSB	CL-7-SLP-1 CL-7-SLP-2 CL-7-SLP-3	1.0000	2	4-3/4	2-3/4	1-9/16	CL-1/2-13x1.50-SHCS	CL-6-32x.50-SHCS	CL-10-32x.50-SHCS	CL-1/4-20x.75-SHCS
HEAVY	CL-MF50-3904	CL-10A-SSB CL-20A-SSB CL-30A-SSB	CL-10C-SSB CL-20C-SSB CL-30C-SSB	CL-7A-SLP-1 CL-7A-SLP-2 CL-7A-SLP-3	1.5000	2	4-3/4	2-3/4	1-9/16	CL-5/8-11x2.25-SHCS	CL-6-32x.50-SHCS	CL-10-32x.50-SHCS	CL-1/4-20x.75-SHCS

HORIZONTAL V BLOCKS

1045 STEEL, HEAT TREATED, BLACK OXIDE FINISH

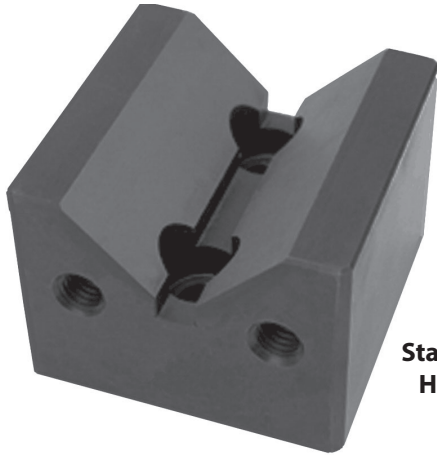

Standard Heavy

Extremely versatile locator for cylindrical workpieces. Locating surface is precision ground and accurately qualified with respect to the mounting holes. Two tapped holes in the side can be used to mount end stops or clamps. Available in two types: one for small diameters, and one for larger diameters.

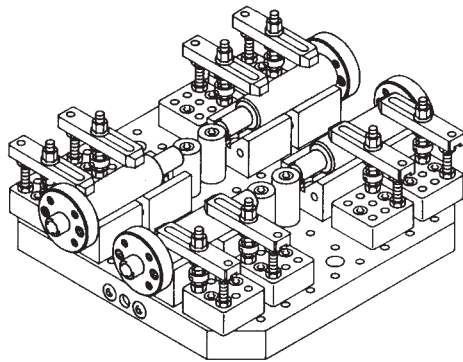

In the above example, Support Cylinders are used as end stops for shafts located in Horizontal V Blocks.

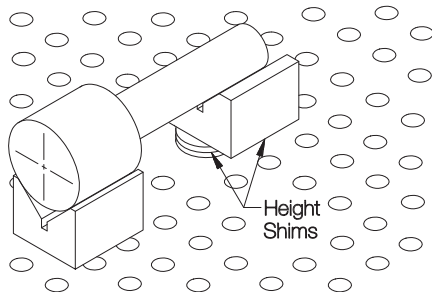

To locate a workpiece from two different diameters simultaneously, use Height Shims (**INFO+** page 227) to raise one V block to the proper level.

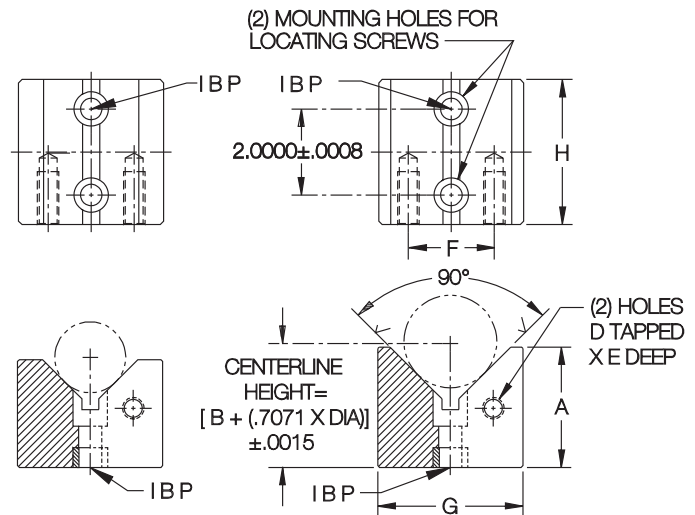

Standard—Small V

**Standard—Large V
Heavy—Large V**

SMALL V

SIZE	PART NO.	WORKPIECE DIAMETER RANGE	A	B	D	E	F	G	H	LOCATING SCREWS (2 REQD)	SOCKET-HEAD CAP SCREWS (0 OR 2 REQD)
STANDARD	CL-MF40-6001	9/16 to 3-1/8	2-1/2	1.3951	1/2-13	1-1/8	2	3-3/8	3-3/8	CL-MF40-4302	—

LARGE V

STANDARD	CL-MF40-6002	9/16 to 4	3	1.5858	1/2-13	1-1/8	2	3-3/8	3-3/8	CL-MF40-4302	—
HEAVY	CL-MF50-6002	9/16 to 4	3	1.5858	5/8-11	1-3/8	2	3-3/8	3-3/8	CL-MF50-4302	—

VERTICAL V BLOCKS

1045 STEEL, HEAT TREATED, BLACK OXIDE FINISH

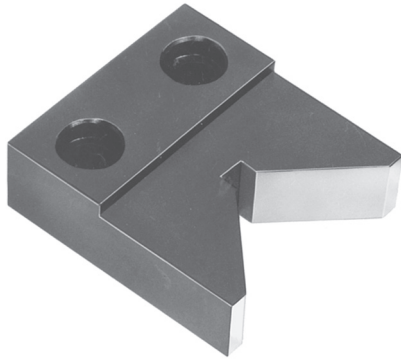

**Standard
Heavy**

Ideal for mounting a cylindrical workpiece with its axis perpendicular to the tooling surface. Locating surfaces are precision ground and accurately qualified with respect to the mounting holes.

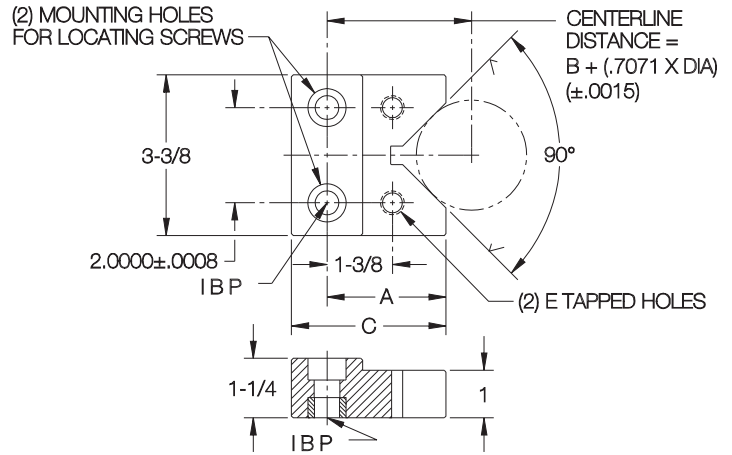

SIZE	PART NO.	WORKPIECE DIAMETER RANGE	A	B	C	E	LOCATING SCREWS (2 REQD)
STANDARD	CL-MF40-6101	9/16 to 3-1/8	2-1/2	1.3951	3-1/4	1/2-13	CL-MF40-4302
HEAVY	CL-MF50-6101	9/16 to 3-1/8	2-1/2	1.3951	3-1/4	5/8-11	CL-MF50-4302

HEIGHT SHIMS

1010 STEEL

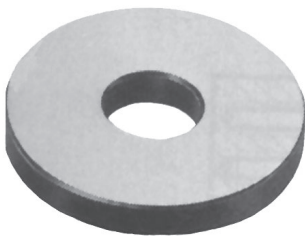

**Standard
Heavy**

Precision shims that allow raising a height locator by a small, exact amount. Ideal when supporting at different levels underneath a workpiece, as in the example shown using Support Cylinders. Thickness tolerance is $\pm .0003$ on .125 size, $\pm 10\%$ on smaller sizes.

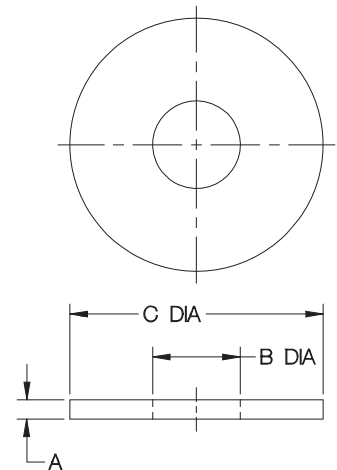
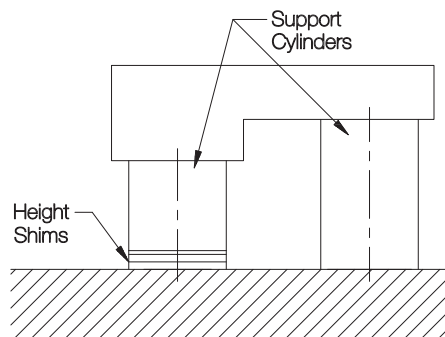

SIZE	PART NO.	A	B DIA	C DIA
STANDARD	CL-MF40-7005	.005	9/16	1-5/8
	CL-MF40-7010	.010		
	CL-MF40-7020	.020		
	CL-MF40-7125	1.25		
HEAVY	CL-MF50-7005	.005	11/16	1-7/8
	CL-MF50-7010	.010		
	CL-MF50-7020	.020		
	CL-MF50-7125	1.25		

MANUAL WORK SUPPORTS

BODY & PLUNGER: CARBON STEEL, CASE HARDENED, BLACK OXIDE FINISH
HANDLE: ZINC DIE CASTING, ENAMEL PAINT



**Standard
Heavy**

Spring-extended manual work support with an extremely low profile. Plunger is locked at proper height by tightening handle. If desired, lock plunger in retracted position for easier loading of light parts, then release and retighten to extend and support. Adjustable handle can be reset to any convenient angle.

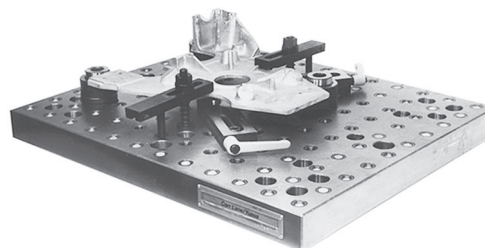

Ideal for supporting in hard-to-reach places, such as underneath this casting. Work supports can be positioned to allow convenient handle access.

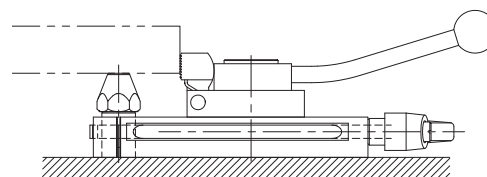

A Screw Rest Pad, available from 1/4" to 2" tall, is an ideal contact bolt to use in the support plunger. For an adjustable contact screw, use a Knurled Screw Jack. The mounting slot allows stacking other components, such as this Cam Edge Clamp, on top of the support.

SIZE	PART NO.	TAPPED HOLE IN PLUNGER	HEIGHT WITH PLUNGER FULLY RETRACTED	MAX PLUNGER STROKE	DISTANCE FROM PLUNGER TO SLOT	SLOT LENGTH	SOCKET-HEAD CAP SCREW (1 REQD.)
STANDARD	CL-MF40-5701	1/2-13	.945	.236	1-9/16	3-9/16	CL-1/2-13x1.50-SHCS
HEAVY	CL-MF50-5702	5/8-11	1.339	.433	1-3/4	3-15/16	CL-5/8-11x2.00-SHCS

KNURLED SCREW JACKS

1215 STEEL, CARBURIZED-HARDENED, BLACK OXIDE FINISH



**Standard
Heavy**

Knurled head allows quick, easy finger adjustment. Order Check Nut separately.

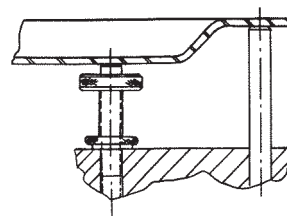

SIZE	KNURLED SCREW JACK PART NO.	CHECK NUT PART NO.	THREAD SIZE	LENGTH UNDER HEAD
STANDARD	CL-7-KSJ	CL-1213-TSJNI	1/2-13	2-1/2
HEAVY	CL-10-KSJ	CL-5811-TSJNI	5/8-11	2-1/2

HEAVY-DUTY SCREW JACKS

JACK SCREW: 4135 STEEL, HEAT TREATED, BLACK OXIDE FINISH
 TIP: 1144 OR 1045 STEEL, HEAT TREATED, BLACK OXIDE FINISH
 BODY: 1045 STEEL, BLACK OXIDE FINISH



Standard Heavy

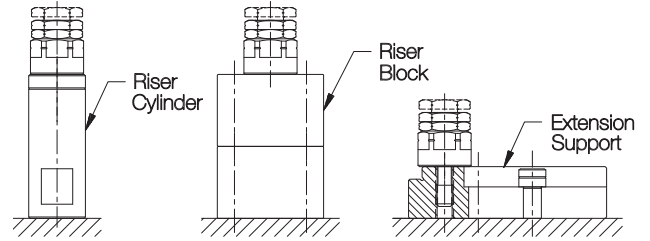

For additional height and/or mounting between grid points, use Riser Cylinders, Support Riser Blocks, or Extension Supports.

Heavy-duty adjustable support that accepts any of the three tips shown below. Choice of three heights in each size cover the full range of height possibilities.

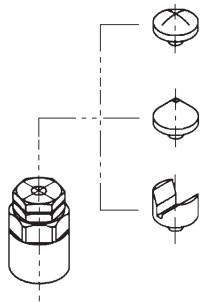

SCREW JACKS

SIZE	PART NO.	MOUNTING SCREW SIZE	OUTSIDE DIAMETER	RETRACTED HEIGHT	MAX SCREW TRAVEL
STANDARD	CL-MF40-3401	1/2-13	1-9/16	1-5/8	3/8
	CL-MF40-3402			2	3/4
	CL-MF40-3403			2-3/4	1-1/2
HEAVY	CL-MF50-3401	5/8-11	1-9/16	1-5/8	3/8
	CL-MF50-3402			2	3/4
	CL-MF50-3403			2-3/4	1-1/2

SCREW-JACK TIPS

SIZE	PART NO.	TYPE	OUTSIDE DIAMETER	OVERALL TIP HEIGHT
ALL	CL-MF10-3501	RADIUS	1-3/16	3/8
	CL-MF10-3502	CONICAL		11/16
	CL-MF10-3503	V-SHAPED		11/16

TORQUE SCREW JACKS

1215 STEEL, BLACK OXIDE FINISH



Standard Heavy

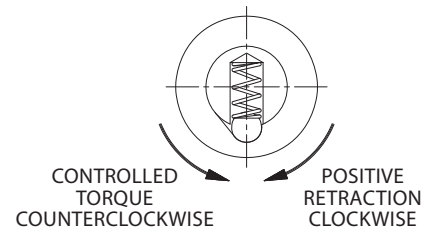

A knurled-head screw jack that declutches at a preset torque. When the indicated end force is reached, the head disengages and turns freely. This eliminates the possibility of exerting excess force on thinwall parts. Knurled Check Nut is furnished.

SIZE	PART NO.	THREAD SIZE	END FORCE (LBS)	LENGTH UNDER HEAD
STANDARD	CL-6-TSJ	1/2-13	18-20	1-3/4
HEAVY	CL-8-TSJ	5/8-11	20-22	1-3/4

FORGED ADJUSTABLE CLAMPS

FORGED 1045 STEEL, BLACK OXIDE FINISH



**Standard
Heavy**

Rugged forged steel pivot clamp. Instant height adjustment without blocks or shims. One-piece assembly allows quick setups and eliminates lost clamp pieces. Removable brass heel protects machine table. Clamp can swing 90° in either direction for loading clearance.

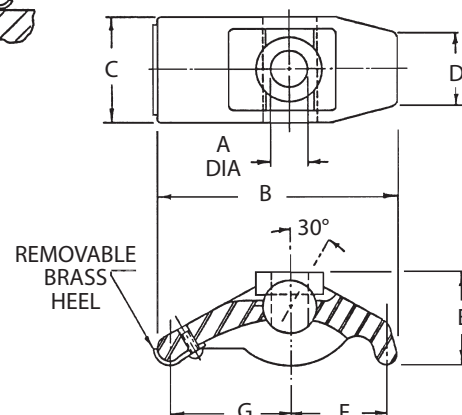
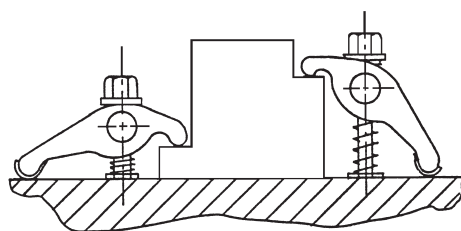

CLAMP STRAPS

SIZE	PART NO.	STUD SIZE	CLAMPING RANGE	A DIA	B	C	D	E	F	G
STANDARD	CL-8-FAC	1/2 or M12	0 to 2-1/16	9/16	4	1-5/8	1-1/8	1-7/16	1-7/16	2-5/16
HEAVY	CL-10-FAC	5/8 or M16	0 to 3	11/16	5-1/2	1-7/8	1-3/8	1-7/8	2	3-1/4



**Assembly with Flange Nut
CL-x-FACA-FN**



**Assembly with Hand Knob
CL-x-FACA-HK**

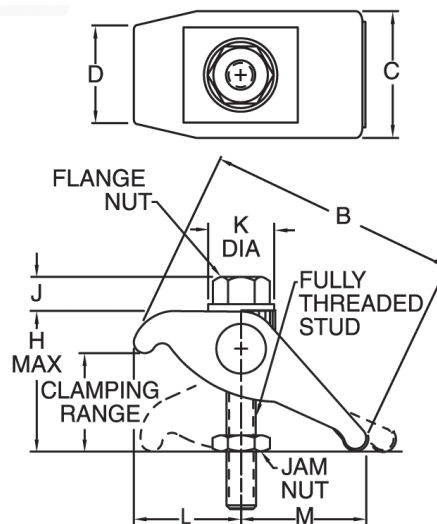

ASSEMBLIES (INCH)

SIZE	PART NO.	STUD SIZE	CLAMPING RANGE	H	J	K DIA	L		M		FORGED ADJUSTABLE CLAMP	FULLY THREADED STUD	JAM NUT	FLANGE NUT
							MIN	MAX	MIN	MAX				
STANDARD	CL-8-FACA-FN	1/2-13	0 to 2-1/16	2-5/8	11/16	1-1/8	1-3/8	1-9/16	2-1/8	2-7/16	CL-8-FAC	CL-1-2-13x4.00-FTS	CL-8-JN	CL-3-FN
HEAVY	CL-10-FACA-FN	5/8-11	0 to 3	3-3/4	13/16	1-3/8	1-13/16	2-1/8	2-15/16	3-3/8	CL-10-FAC	CL-5/8-11x5.00-FTS	CL-10-JN	CL-4-FN

SLOTTED-HEEL CLAMP STRAPS

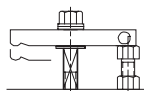

Short Clamp-Strap Assembly (see below)

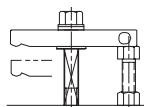

Tall Clamp-Strap Assembly (see below)

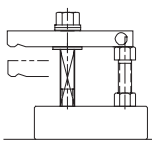

Tall Clamp-Strap Assembly - **INFO+**: on Riser Block (p. 432) or Riser Cylinders (p. 445)

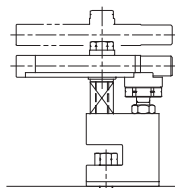

High-Rise Clamp (**INFO+**: p. 442)

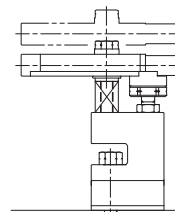

High-Rise Clamp on Spacer Block (**INFO+**: p. 443)

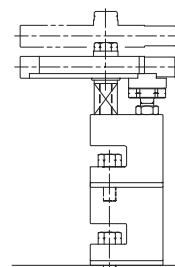

High-Rise Clamp on Narrow Riser Block (**INFO+**: p. 443)

Our most-popular clamp strap, with a slot underneath to allow sliding it straight back for clear loading. Choose from three different fastening devices, each available in a short or tall version, and two clamp-strap lengths. Order components individually (page numbers listed are in the tooling-component catalog section).



Standard Heavy

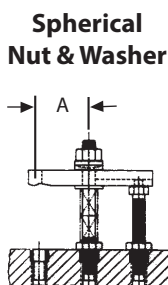

Spherical Nut & Washer

SPHERICAL NUT & WASHER (SHORT)

SIZE	CLAMPING HEIGHT RANGE	CLAMP STRAP (INFO+ : p. 263)			CLAMP REST (p. 327)	CLAMP SPRINGS (p. 328)	FLAT WASHER (p. 315)	JAM NUT (p. 311)	STUD (p. 317)	SPHER. NUT & WASHER (p. 313)
		PART NO.	LENGTH	A						
STANDARD	0 to 1-3/8	CL-8-CS	5	2-1/4	CL-4-CR	CL-9-SPG	CL-2-FW	CL-8-JN	CL-1/2-13x4.00	CL-3-SNW
		CL-10-CS	6	2-3/4						
HEAVY	0 to 1-3/8	CL-16-CS	5	2-3/16	CL-6-CR	CL-11-SPG	CL-3-FW	CL-10-JN	CL-5/8-11x4.50	CL-4-SNW
		CL-18-CS	6	2-11/16						

SPHERICAL NUT & WASHER (TALL)

STANDARD	1-3/8 to 2-3/4	CL-8-CS	5	2-1/4	CL-5-CR	(2) CL-9-SPG	CL-2-FW	CL-8-JN	CL-1/2-13x5.50	CL-3-SNW
		CL-10-CS	6	2-3/4						
HEAVY	1-3/8 to 2-1/2	CL-16-CS	5	2-3/16	CL-7-CR	(2) CL-11-SPG	CL-3-FW	CL-10-JN	CL-5/8-11x5.50	CL-4-SNW
		CL-18-CS	6	2-11/16						



Standard Heavy

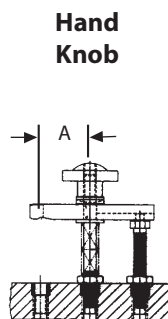

Hand Knob

HAND KNOB (SHORT)

SIZE	CLAMPING HEIGHT RANGE	CLAMP STRAP (INFO+ : p. 263)			CLAMP REST (p. 327)	CLAMP SPRINGS (p. 328)	FLAT WASHER (p. 315)	JAM NUT (p. 311)	STUD (p. 317)	HAND KNOB (p. 100)	SPHERICAL WASHER (p. 314)
		PART NO.	LENGTH	A							
STANDARD	0 to 1-3/8	CL-8-CS	5	2-1/4	CL-4-CR	CL-9-SPG	CL-2-FW	CL-8-JN	CL-1/2-13x4.00	CL-4-HK-4	CL-3-SW
		CL-10-CS	6	2-3/4							
HEAVY	0 to 1-3/8	CL-16-CS	5	2-3/16	CL-6-CR	CL-11-SPG	CL-3-FW	CL-10-JN	CL-5/8-11x4.50	CL-10-HK-10	CL-4-SW
		CL-18-CS	6	2-11/16							

HAND KNOB (TALL)

STANDARD	1-3/8 to 2-3/4	CL-8-CS	5	2-1/4	CL-5-CR	(2) CL-9-SPG	CL-2-FW	CL-8-JN	CL-1/2-13x5.50	CL-4-HK-4	CL-3-SW
		CL-10-CS	6	2-3/4							
HEAVY	1-3/8 to 2-1/2	CL-16-CS	5	2-3/16	CL-7-CR	(2) CL-11-SPG	CL-3-FW	CL-10-JN	CL-5/8-11x5.50	CL-10-HK-10	CL-4-SW
		CL-18-CS	6	2-11/16							

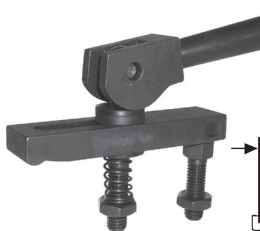

Standard Heavy

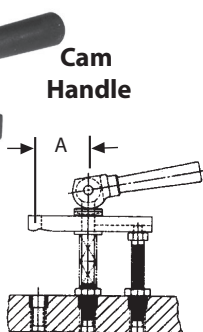

Cam Handle

CAM HANDLE (SHORT)

SIZE	CLAMPING HEIGHT RANGE	CLAMP STRAP (INFO+ : p. 263)			CLAMP REST (p. 327)	CLAMP SPRINGS (p. 328)	FLAT WASHER (p. 315)	JAM NUT (p. 311)	SPHERICAL WASHER (p. 314)	CAM HANDLE (p. 326)	EYE BOLT (p. 325)	CLEVIS PIN (p. 355)
		PART NO.	LENGTH	A								
STANDARD	0 to 1-3/8	CL-8-CS	5	2-1/4	CL-4-CR	CL-9-SPG	CL-2-FW	CL-8-JN	CL-3-SW	CL-13-CH	CL-50-EB	CL-1218-CLVP
		CL-10-CS	6	2-3/4								
HEAVY	0 to 1-3/8	CL-16-CS	5	2-3/16	CL-6-CR	CL-11-SPG	CL-3-FW	CL-10-JN	CL-4-SW	CL-14-CH	CL-62-EB	CL-2020-CLVP
		CL-18-CS	6	2-11/16								

CAM HANDLE (TALL)

STANDARD	1-3/8 to 2-3/4	CL-8-CS	5	2-1/4	CL-5-CR	(2) CL-9-SPG	CL-2-FW	CL-8-JN	CL-3-SW	CL-13-CH	CL-51-EB	CL-1218-CLVP
		CL-10-CS	6	2-3/4								
HEAVY	1-3/8 to 2-1/2	CL-16-CS	5	2-3/16	CL-7-CR	(2) CL-11-SPG	CL-3-FW	CL-10-JN	CL-4-SW	CL-14-CH	CL-63-EB	CL-2020-CLVP
		CL-18-CS	6	2-11/16								

DOUBLE-END CLAMP STRAPS

A clamp-strap assembly with two clamping ends, for holding two workpieces simultaneously. Choose from three different fastening devices, each available in a short or tall version, and two clamp-strap lengths. Order components individually.



Spherical Nut & Washer

Standard Heavy

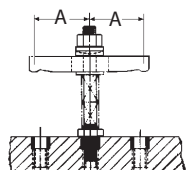

SPHERICAL NUT & WASHER (SHORT)

SIZE	CLAMPING-HEIGHT RANGE	CLAMP STRAP (INFO++: p. 276)			CLAMP SPRINGS (p. 330)	FLAT WASHER (p. 316)	JAM NUT (p. 312)	STUD (p. 318)	SPHERICAL NUT & WASHER (p. 314)
		PART NO.	LENGTH	A					
STANDARD	0 to 1-3/8	CL-28-CS	5	2-19/64	CL-9-SPG	CL-2-FW	CL-8-JN	CL-1/2-13x4.00	CL-3-SNW
		CL-30-CS	6	2-51/64					
HEAVY	0 to 1-3/8	CL-32A-CS	5	2-1/4	CL-11-SPG	CL-3-FW	CL-10-JN	CL-5/8-11x4.50	CL-4-SNW
		CL-33-CS	6	2-3/4					

SPHERICAL NUT & WASHER (TALL)

STANDARD	1-3/8 to 2-3/4	CL-28-CS	5	2-19/64	(2) CL-9-SPG	CL-2-FW	CL-8-JN	CL-1/2-13x5.50	CL-3-SNW
HEAVY	1-3/8 to 2-1/2	CL-32A-CS	5	2-1/4	(2) CL-11-SPG	CL-3-FW	CL-10-JN	CL-5/8-11x5.50	CL-4-SNW
		CL-33-CS	6	2-3/4					



Hand Knob

Standard Heavy

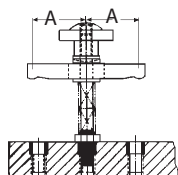

HAND KNOB (SHORT)

SIZE	CLAMPING-HEIGHT RANGE	CLAMP STRAP (INFO++: p. 276)			CLAMP SPRINGS (p. 330)	FLAT WASHER (p. 316)	JAM NUT (p. 312)	STUD (p. 318)	HAND KNOB (p. 100)	SPHERICAL NUT & WASHER (p. 314)
		PART NO.	LENGTH	A						
STANDARD	0 to 1-3/8	CL-28-CS	5	2-19/64	CL-9-SPG	CL-2-FW	CL-8-JN	CL-1/2-13x4.00	CL-4-HK-4	CL-3-SW
		CL-30-CS	6	2-51/64						
HEAVY	0 to 1-3/8	CL-32A-CS	5	2-1/4	CL-11-SPG	CL-3-FW	CL-10-JN	CL-5/8-11x4.50	CL-10-HK-10	CL-4-SW
		CL-33-CS	6	2-3/4						

HAND KNOB (TALL)

STANDARD	1-3/8 to 2-3/4	CL-28-CS	5	2-19/64	(2) CL-9-SPG	CL-2-FW	CL-8-JN	CL-1/2-13x5.50	CL-4-HK-4	CL-3-SW
		CL-30-CS	6	2-51/64						
HEAVY	1-3/8 to 2-1/2	CL-32A-CS	5	2-1/4	(2) CL-11-SPG	CL-3-FW	CL-10-JN	CL-5/8-11x5.50	CL-10-HK-10	CL-4-SW
		CL-33-CS	6	2-3/4						

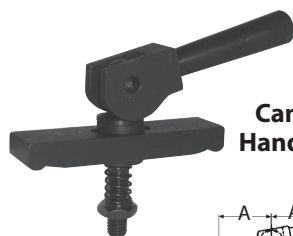

Cam Handle

Standard Heavy

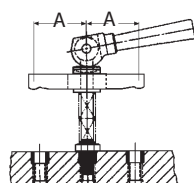

CAM HANDLE (SHORT)

SIZE	CLAMPING-HEIGHT RANGE	CLAMP STRAP (INFO++: p. 276)			CLAMP SPRINGS (p. 330)	FLAT WASHER (p. 316)	JAM NUT (p. 312)	SPHERICAL NUT & WASHER (p. 314)	CAM HANDLE (p. 327)	EYE BOLT (p. 326)	DOWEL PIN (p. 248)
		PART NO.	LENGTH	A							
STANDARD	0 to 1-3/8	CL-28-CS	5	2-19/64	CL-9-SPG	CL-2-FW	CL-8-JN	CL-3-SW	CL-13-CH	CL-50-EB	CL-3/8x1.00-CADP
		CL-30-CS	6	2-51/64							
HEAVY	0 to 1-3/8	CL-32A-CS	5	2-1/4	CL-11-SPG	CL-3-FW	CL-10-JN	CL-4-SW	CL-14-CH	CL-62-EB	CL-5/8x1.25-CADP
		CL-33-CS	6	2-3/4							

SPHERICAL NUT & WASHER (TALL)

STANDARD	1-3/8 to 2-3/4	CL-28-CS	5	2-19/64	(2) CL-9-SPG	CL-2-FW	CL-8-JN	CL-3-SW	CL-13-CH	CL-51-EB	CL-3/8x1.00-CADP
		CL-30-CS	6	2-51/64							
HEAVY	1-3/8 to 2-1/2	CL-32A-CS	5	2-1/4	(2) CL-11-SPG	CL-3-FW	CL-10-JN	CL-4-SW	CL-14-CH	CL-63-EB	CL-5/8x1.25-CADP
		CL-33-CS	6	2-3/4							

HIGH-RISE CLAMPS

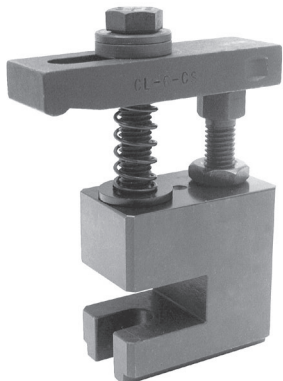

Slotted Heel

Standard Heavy

For clamping taller workpieces. All-in-one clamp construction for quick, safe setups. Modular design allows stacking for height flexibility. Clamp Straps slide back for loading clearance.

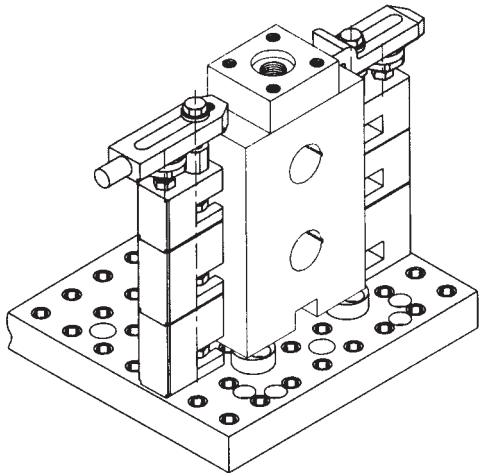

High-Rise Clamps can be stacked on Narrow Riser Blocks and Spacer Blocks (INFO+ page 430) to reach tall workpieces.

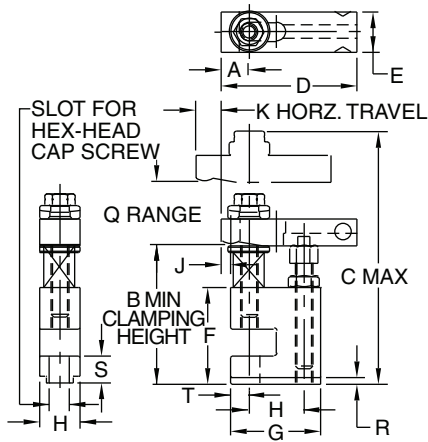

SLOTTED HEEL HIGH-RISE CLAMPS

SIZE	PART NO.	A	B	C	D	E	F	G	H	J	K	Q	R	S	T	HEX-HEAD CAP SCREW (1 REQD)
STANDARD	CL-MF40-2051	23/32	3-5/8	5-3/4	4	1-1/4	2-3/4	2-3/4	1-9/16	13/64	1-9/32	1	3/16	13/16	9/16	CL-MF40-4311
HEAVY	CL-MF50-2051	29/32		7-1/4	5	1-1/2	2-15/16	3-9/16	2	1/4	1-19/32				13/16	CL-MF50-4311

* Use CL-MF25-4311 when mounted on a Narrow Riser Block.

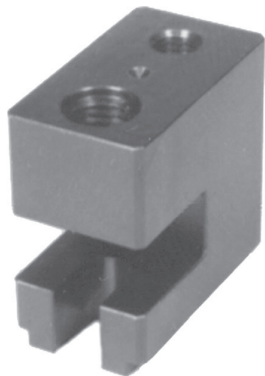

Adaptor Base

Standard Heavy

Adaptor used in the assembly above. Also allows using other types of clamp straps as high-rise clamps.

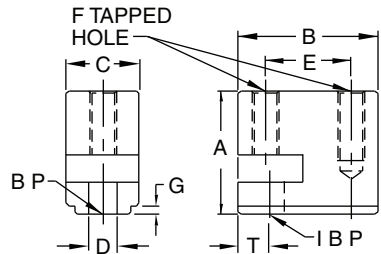

ADAPTOR BASES

SIZE	PART NO.	A	B	C	D	E	F	G	HEX-HEAD CAP SCREW (1 REQD)
STANDARD	CL-MF40-1901	2-3/4	2-3/4	1-9/16	9/16	1-9/16	1/2-13	3/16	CL-MF40-4311
HEAVY	CL-MF50-1901	2-15/16	3-9/16	2	11/16	2	5/8-11	3/16	CL-MF50-4311

10

HIGH-RISE-CLAMP ACCESSORIES

CARBON STEEL, BLACK OXIDE FINISH

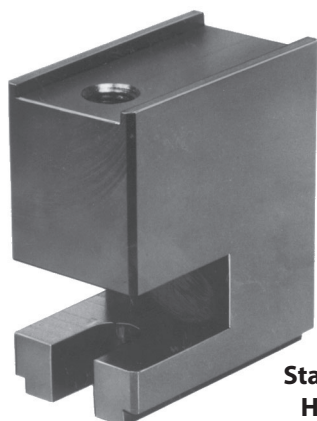

Narrow Riser Block

Standard Heavy

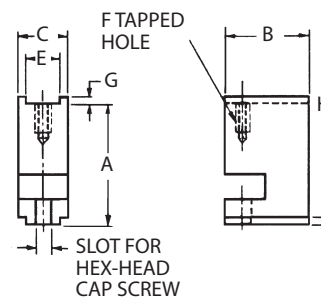
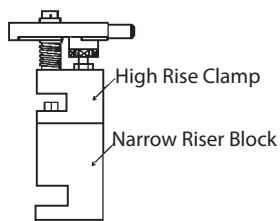

NARROW RISER BLOCKS

These Narrow Riser Blocks are used to raise up High-Rise Clamps to reach tall workpieces. Interlocking channels ensure that clamps and risers remain properly aligned when stacked up. Clamps and risers are fastened to the tapped hole on top of the riser block.

SIZE	PART NO.	A	B	C	E	F	G	H	HEX-HEAD CAP SCREW (1 REQD)
STANDARD	CL-MF40-2301	3	2-3/4	1-9/16	1-3/16	1/2-13	1/8	3/16	CL-MF40-4311
HEAVY	CL-MF50-2301	3	3-9/16	2	1-9/16	5/8-11	1/8	3/16	CL-MF50-4311

10

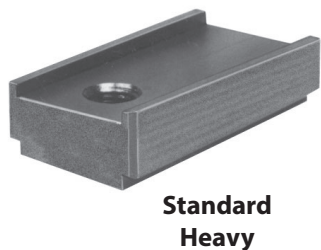

Spacer Block

Standard Heavy

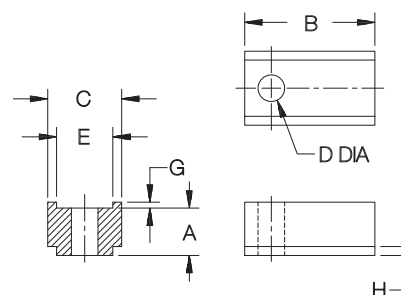
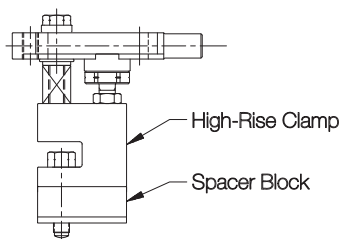

A shorter version of the Narrow Riser Block for raising height only slightly. These blocks also have interlocking channels and can be stacked. Note: A longer hex-head cap screw is required to mount the High-Rise Clamp when using a Spacer Block.

SPACER BLOCKS

SIZE	PART NO.	A	B	C	D DIA	E	G	H
STANDARD	CL-MF40-2351	1	2-3/4	1-9/16	17/32	1-3/16	1/8	3/16
HEAVY	CL-MF50-2351	1	3-9/16	2	11/16	1-9/16	1/8	3/16

HOOK CLAMPS

CLAMP BODY: 4135 STEEL, HEAT TREATED, BLACK OXIDE FINISH
 HOLDER: 1045 STEEL, BLACK OXIDE FINISH

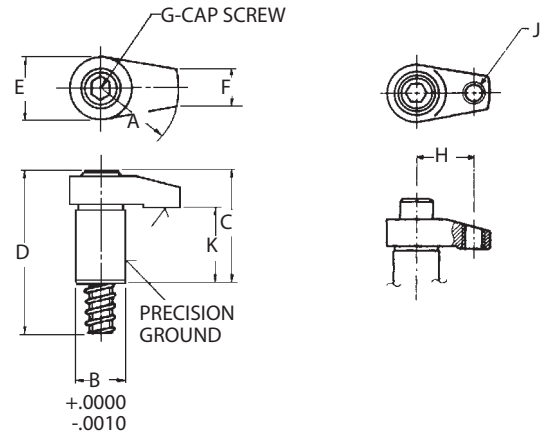

Versatile Hook Clamps available with either a plain or tapped arm. The tapped-arm version accepts a wide variety of contact bolts or adjustment spindles to increase clamping range (the tapped arm is also slightly longer).

LONG-ARM HOOK CLAMPS

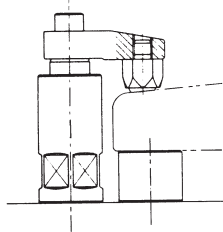

SIZE	PART NO.	A	B DIA	C	D	E	F	G	H	J	K
STANDARD	CL-MF40-5002	2	1.0000	2-1/2	3-1/2	1-1/4	11/16	1/2-13x3.00	—	—	1-17/32
HEAVY	CL-MF50-5002	2	1.2500	2-7/8	3-7/8	1-7/16	7/8	5/8-11x3.25	—	—	1-17/32

TAPPED LONG-ARM HOOK CLAMPS

SIZE	PART NO.	A	B DIA	C	D	E	F	G	H	J	K
STANDARD	CL-MF40-5013	2-3/8	1.0000	2-1/2	3-1/2	1-1/4	11/16	1/2-13x3.00	1-13/16	1/2-13	1-17/32
HEAVY	CL-MF50-5014	2-3/8	1.2500	2-7/8	3-7/8	1-7/16	7/8	5/8-11x3.25	1-13/16	5/8-11	1-17/32

Hook Clamps work well in conjunction with Support Cylinders or Screw Rest Pads to allow clamping directly over a supported point.

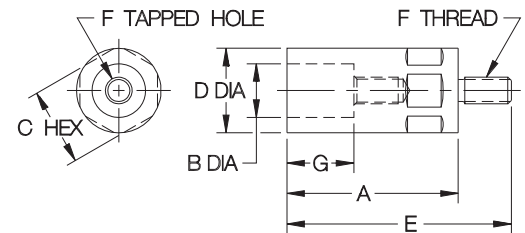
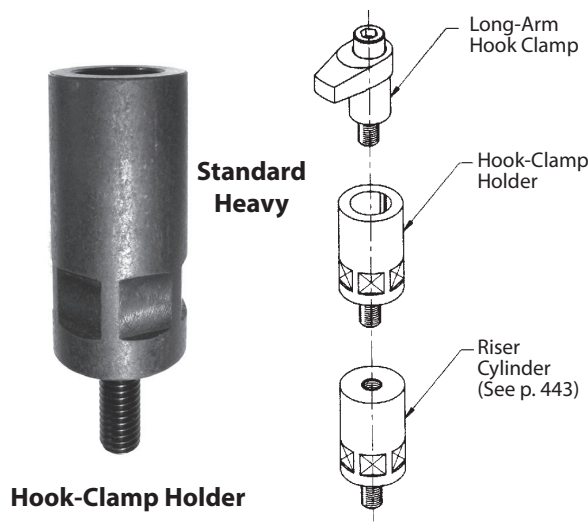

HOOK-CLAMP HOLDERS

SIZE	PART NO.	F THREAD SIZE	A	B DIA	C	D DIA	E	G
STANDARD	CL-MF40-5101	1/2-13	3-1/8	1.0000	1-7/16	1-9/16	4-3/8	1-9/16
	CL-MF40-5102		4				5-1/4	
HEAVY	CL-MF50-5101	5/8-11	3-1/8	1.2500	1-3/4	2	4-3/8	1-9/16
	CL-MF50-5102		4				5-1/4	

HOOK CLAMPS

MOUNTING BLOCKS: 1045 STEEL, BLACK OXIDE FINISH

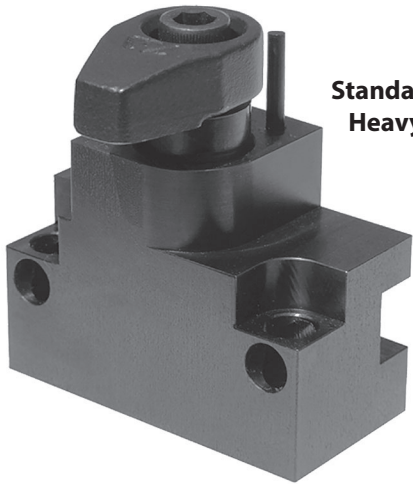

**Standard
Heavy**

These mounting blocks for long-arm Hook Clamps have built-in 90° stops that provide consistent arm positioning in both clamped and unclamped position. Two sets of mounting holes allow either base mounting or side mounting. Precision bored hole for smooth swing action. Available for all three sizes of long-arm Hook Clamps.

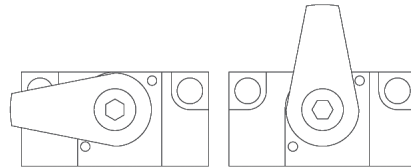

**Hook-Clamp Mounting Block
(order Hook-Clamp separately)**

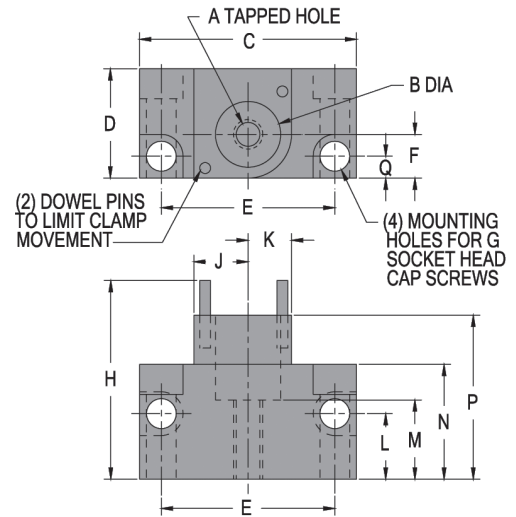

HOOK-CLAMP MOUNTING BLOCKS

SIZE	PART NO.	A	B	C	D	E	F	G	H	J	K	L	M	N	P	Q
STANDARD	CL-MF40-5801	1/2-13	1.0000	2-3/4	2	2	1	1/2-13	3-3/4	1	3/4	1	1-5/32	1-7/8	2-3/4	3/8
HEAVY	CL-MF50-5801	5/8-11	1.2500	5	2	4	1	5/8-11	3-3/4	1	1	1-1/4	1-5/32	2-1/4	2-3/4	1/2

RISER CYLINDERS

1045 STEEL, BLACK OXIDE FINISH



**Standard
Heavy**

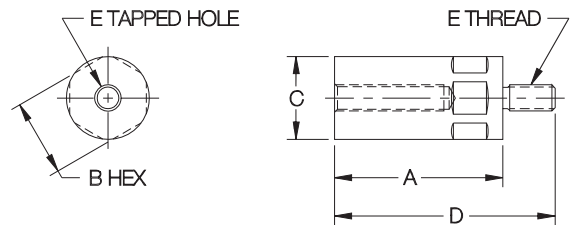
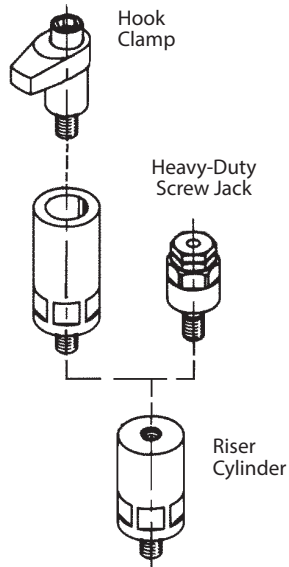

Provides additional height without taking up much space. Useful with Hook Clamps, and Heavy-Duty Screw Jacks.

SIZE	PART NO.	A	B	C DIA	D	E
STANDARD	CL-MF40-5201	2	1-7/16	1-9/16	3-1/4	1/2-13
	CL-MF40-5203	3-1/8			4-3/8	
	CL-MF40-5204	4			5-1/4	
HEAVY	CL-MF50-5201	2	1-13/16	2	3-1/4	5/8-11
	CL-MF50-5203	3-1/8			4-3/8	
	CL-MF50-5204	4			5-1/4	

SWIVEL CONTACT BOLTS

BALL: CHROME STEEL, HEAT TREATED RC 60-67
 BODY: 1144 STEEL, HEAT TREATED RC 35-40, BLACK OXIDE FINISH



**Standard
Heavy**

Precision swivel ball that can be used as either a contact bolt or rest pad. Ideal for evenly distributing clamping pressure on sloped surfaces.

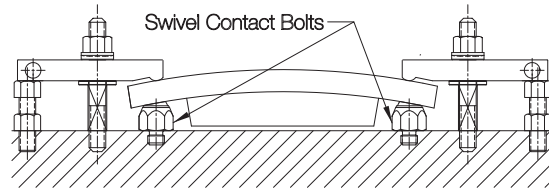

Swivel Contact Bolts are precision ground for accurate height location, even on sloped surfaces.

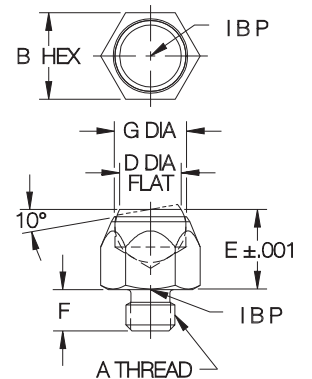
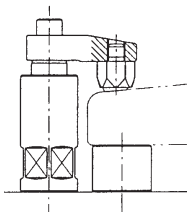

SIZE	PART NO.	A	B	D DIA	E	F	G DIA
STANDARD	CL-MF40-2501	1/2-13	7/8	5/8	.8125	.41	23/32
HEAVY	CL-MF50-2501	5/8-11	1-1/16	13/16	1.0000	.61	29/32

STANDARD-ADJUSTABLE SPINDLES

CARBON STEEL, ZINC PLATED CLEAR CHROMATE

10



**Standard
Heavy**

Long hex-head contact bolt. Fully threaded for maximum adjustment range.

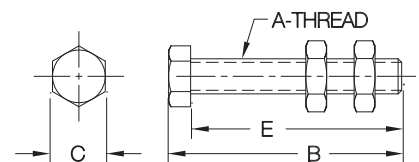

SIZE	PART NO.	A	B	C	E
STANDARD	CL-12314-SA	1/2-13	3-5/16	3/4	3
HEAVY	CL-58438-SA	5/8-11	4-3/8	15/16	4

UP-THRUST CLAMPS

STEEL, WEAR SURFACES HARDENED, BLACK OXIDE FINISH



Standard

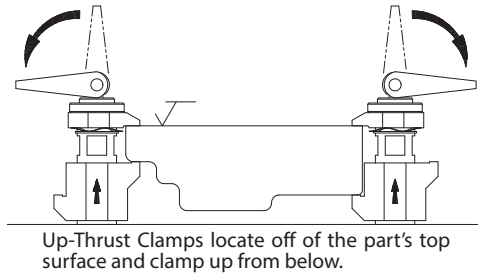

Up-Thrust Clamps locate off of the part's top surface and clamp up from below.

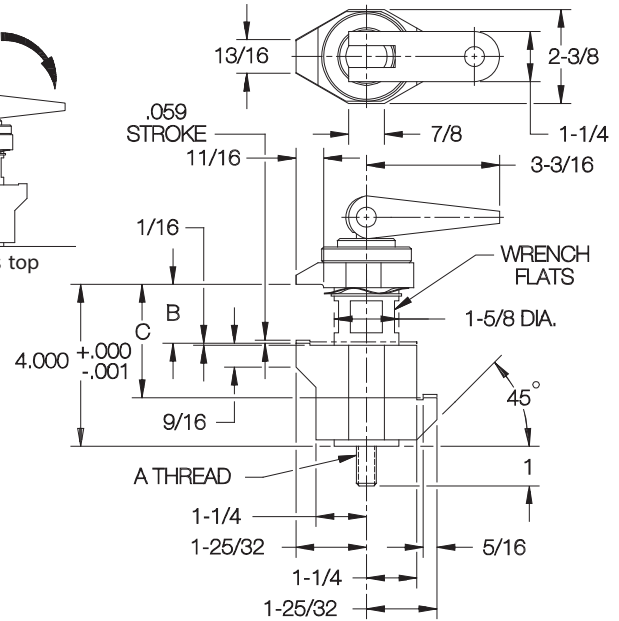

Combination clamp and locator with unique upward clamping action. Pushing down the cam handle pulls the lower jaw upward. This clamps the workpiece against the stationary upper jaw, whose bottom surface is a precision-ground locator.

The lower jaw has two clamping surfaces 180° apart, one for thinner parts, the other for thicker parts. The cam handle rotates to screw the lower jaw up or down for fine adjustment.

SIZE	PART NO.	A	B RANGE		C RANGE		MAX CLAMPING FORCE (LBS)
			MIN	MAX	MIN	MAX	
STANDARD	CL-MF40-5301	1/2-13	0	1-3/8	1-3/8	2-3/4	2200

CAM EDGE CLAMPS

BODY: STEEL, WEAR SURFACES HARDENED, BLACK OXIDE FINISH
BALL HANDLE: BLACK PHENOLIC PLASTIC

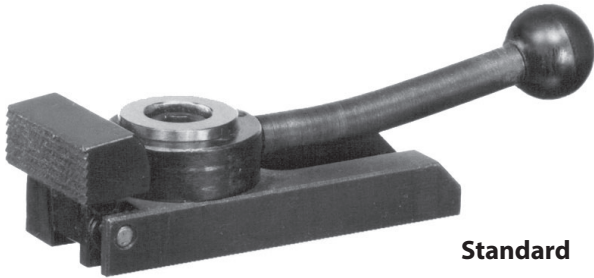

Standard

Pivoting-nose edge clamp operated by a cam handle for fast action. Smooth spiral cam locks positively anywhere within its 180° throw. Choice of clockwise or counterclockwise handle rotation to clamp.

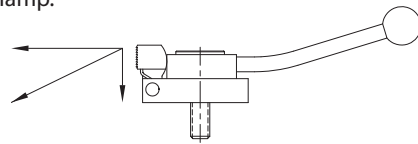

Nose pivots to exert clamping force forward and downward at the same time.

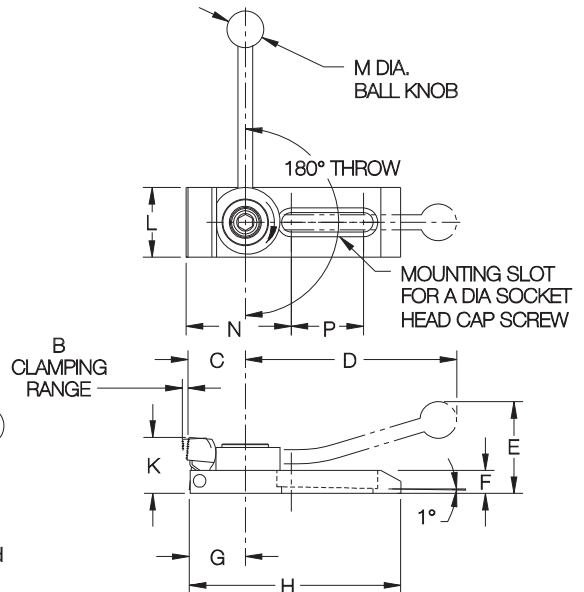

SIZE	PART NO.	CLAMPING DIRECTION	A	B	C	D	E	F	G	H	K		L	M	N	P	MAX CLAMPING FORCE (LBS)		SOCKET-HEAD CAP SCREW (1 REQD)
											MIN	MAX					HORIZ	VERT	
STANDARD	CL-MF40-5611	CLOCKWISE	1/2-13	7/32	1-9/16	5-3/4	2-1/2	5/8	1-1/2	6	1-5/16	1-1/2	1-7/8	1	2-15/16	2	1500	100	CL-1/2-13x1.25-SHCS
	CL-MF40-5612	CCW																	

SERRATED EDGE CLAMPS

BODY AND NOSE: 1018 STEEL, CARBURIZED-HARDENED, BLACK OXIDE FINISH
 CLAMPING SCREW: 4140 STEEL, HEAT TREATED RC 43-45, BLACK OXIDE FINISH
 NOSE COVER: ALUMINUM

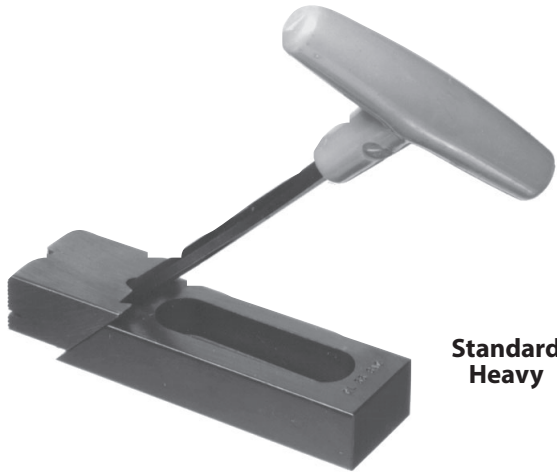

Standard Heavy

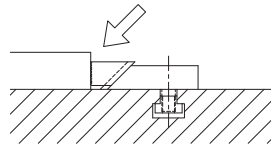

High Nose

High-nose version is best for most applications. Gripping high up on the workpiece, close to the machining plane, provides maximum clamping rigidity. A removable aluminum nose cover is furnished for clamping soft or machined parts without damage.

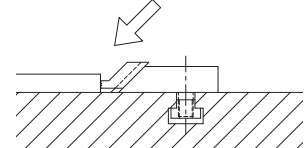

Low Nose

Low-nose version is ideal for thin parts, with its extra machining clearance.

This low-profile clamp is ideal for gripping the side of a workpiece to keep the top clear for machining. Clamps both forward and down simultaneously, by tightening the socket-head screw in the sliding nose with a hex wrench. V-groove in nose is excellent for clamping round parts or corners.

ADJUSTABLE — HIGH NOSE

SIZE	PART NO.	A	B	C	D	E	F	G	H	J	K	L	M	N	P	Q	MOUNTING SCREWS (1 OR 2 REQD)
STANDARD	CL-45-SAC	4	7/8	1-1/2	—	—	—	1-1/4	1/2	5/8	5/16	3-3/16	1/4	—	—	2-1/4	(1) CL-1/2-13x1.50-SHCS
	CL-55-SAC	5-1/2						2-1/8				4-11/16				2-1/2	
	CL-65-SAC	7-1/8						3				6-5/16				2-9/16	
HEAVY	CL-75-SAC	5-1/2	1-1/4	1-3/4	—	—	—	1-3/8	5/8	3/4	5/16	4-1/2	5/16	—	—	3-9/32	(1) CL-5/8-11x2.00-SHCS
	CL-95-SAC	8-1/4						4				7-1/4				3	(2) CL-5/8-11x2.00-SHCS

ADJUSTABLE — LOW NOSE

STANDARD	CL-40-SAC	4	7/8	1-1/2	—	—	—	1-1/4	1/2	—	5/16	3-3/16	1/4	1/4	1/4	2-1/4	(1) CL-1/2-13x1.50-SHCS
	CL-50-SAC	5-1/2						2-1/8				4-11/16				2-1/2	
	CL-60-SAC	7-1/8						3				6-5/16				2-9/16	
HEAVY	CL-70-SAC	5-1/2	1-1/4	1-3/4	—	—	—	1-3/8	5/8	—	5/16	4-1/2	5/16	5/16	5/16	3-9/32	(1) CL-5/8-11x2.00-SHCS
	CL-90-SAC	8-1/4						4				7-1/4				3	(2) CL-5/8-11x2.00-SHCS

FIXED — HIGH NOSE

STANDARD	CL-45-SFC	2-11/16	7/8	1-1/2	2	3	1	—	—	5/8	5/16	1-7/8	1/4	—	—	2-3/16	(2) CL-1/2-13x1.38-FHSS
HEAVY	CL-75-SFC	3-1/2	1-1/4	1-3/4	2	3-1/4	1-1/4	—	—	3/4	5/16	2-1/2	5/16	—	—	2-7/8	(2) CL-5/8-11x2.00-FHSS

FIXED — LOW NOSE

STANDARD	CL-40-SFC	2-11/16	7/8	1-1/2	2	3	1	—	—	5/8	5/16	1-7/8	1/4	1/4	1/4	2-3/16	(2) CL-1/2-13x1.38-FHSS
HEAVY	CL-70-SFC	3-1/2	1-1/4	1-3/4	2	3-1/4	1-1/4	—	—	3/4	5/16	2-1/2	5/16	5/16	5/16	2-7/8	(2) CL-5/8-11x2.00-FHSS

SERRATED EDGE CLAMPS

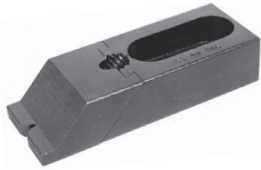

Serrated Adjustable Edge Clamp

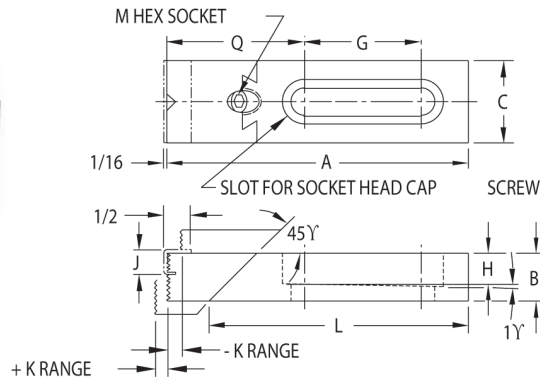

High Nose

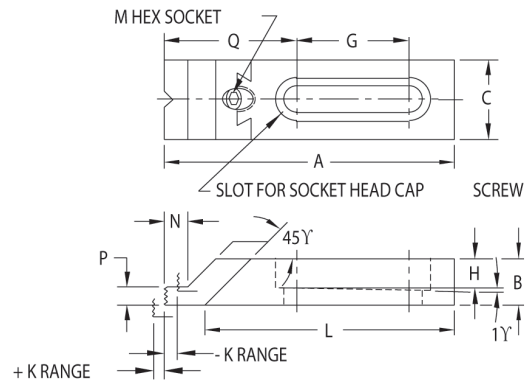

Low Nose

10



Serrated Fixed Edge Clamp

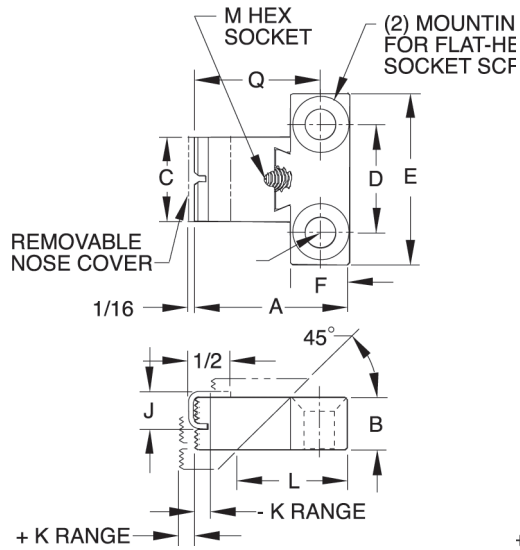

High Nose

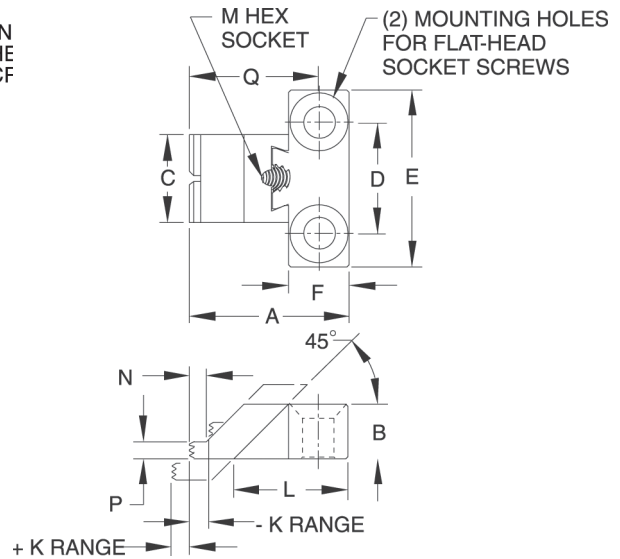

Low Nose



Ideal for Tall Workpieces or Castings Pivoting Edge Clamps

Easy conversion to hydraulic operation!



TOGGLE CLAMPS



**Horizontal-Handle
Hold-Down Clamps**



**Vertical-Handle
Hold-Down Clamps**



**Push/Pull
Clamps**



**Latch-Action
Clamps**



Toggle Pliers



**Air-Powered
Clamps**



**Toggle Clamp
Accessories**

TOGGLE CLAMPS

TOGGLE-ACTION PRINCIPLES

A toggle clamp is a quick-acting mechanical linkage where two of the elements make up a toggle action. Actuating the clamp first moves it into position, then applies clamping force by compressing or stretching the linkage elements after contacting the workpiece, then positively locks it by moving the toggle action's center pivot past the centerline of the other two pivots, against a stop.

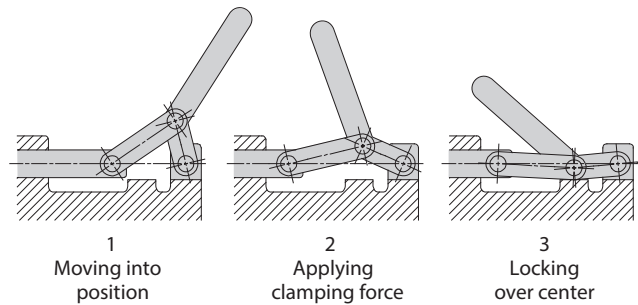

HOLDING CAPACITY

The "holding capacity" listed for each clamp refers to the maximum external force that clamp can safely resist in its locked position without incurring any permanent deformation. For hold-down clamps, holding capacity is measured with the spindle as close as possible to the handle, and will be less at the end of the clamping arm.

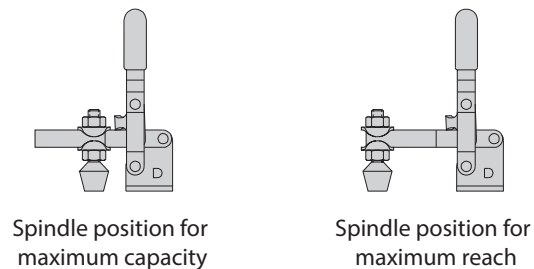

ARM TYPES

Open-arm hold-down clamps offer maximum flexibility and adjustability. Two flanged washers hold the spindle in place anywhere along the arm by tightening the jam nuts.

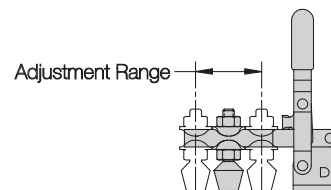

Solid-arm hold-down clamps are easily customized to a particular application. Using the weld-on bolt retainer, you can locate the spindle permanently in one place. The solid-arm version allows mounting the spindle at an angle, or shortening the clamping arm.

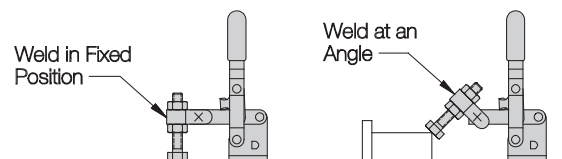

MATERIALS

STEEL

Steel clamps are made from various types including 1008, 1010, 1018, and other fine steels. Pivot pins on most clamp models are 400-series stainless steel for extra durability. Many pivot points have hardened steel bushes for long life. Forged steel components, such as those on toggle pliers and push/pull clamps, are made from high-carbon steel. Many push/pull clamp bases are made of nodular iron for wear resistance.

STAINLESS STEEL

Many toggle-clamp models are available in 300-series stainless steel. These corrosion-resistant clamps are useful in chemical environments, plating operations, food processing, salt-spray environments, medical equipment, electronics fixturing, EDM fixturing, and marine environments. Various stainless steel grades, including 303 and 304, are used. Clamps normally furnished with a flat-cushion spindle in the steel version are supplied with a stainless steel hex-head spindle. Other clamps are available in stainless steel as specials.

**ALL CARR LANE MANUFACTURING
TOGGLE CLAMPS
ARE PROUDLY
MADE IN USA**

TOGGLE CLAMPS

TYPES

All Carr Lane Manufacturing toggle clamps are DFARS and RoHS compliant.



HORIZONTAL-HANDLE

Most popular of all toggle clamps. Clamping weights from 100 to 1,000 lbs. Comfortable finger grip. Options include automatically adjusting, low arm, and extra wide opening. **See page 442.**



VERTICAL-HANDLE

Similar to clamps above, except this version has a vertical handle. Clamping weights from 100 to 1,200 lbs. and heavy duty versions offering clamping power from 750 to 6,000 lbs. **See page 451.**



PUSH/PULL

Push/pull clamps feature a plunger that advances and locks by moving the handle forward. Clamp can also be used for pulling instead of pushing. Clamping weights from 100 to 16,000 lbs. **See page 477.**



LATCH-ACTION

Latch action options include adjustable U Bolt, Right-Angle Adjustable U Bolt, Adjustable Hook, and fixed length. **See page 488.**



PLIERS

Forged steel provides strong clamping action. Clamping weights from 200 to 800 lbs. Includes permanently attached and Toggle Bar Clamps as options. **See page 496.**



AIR-POWERED

This clamp linkage is operated by a double-acting air cylinder instead of by hand. Provides high holding capacity and insures positive mechanical locking even if air pressure fails. **See page 501.**

SELECTION CHART

STYLE	CAPACITY									
	0-99	100-199	200-299	300-499	500-750	751-1000	1,000-1,499	1,500-1,999	2,000-5,000	5,001+
Horizontal Handle	X	X	X	X	X	X				
Heavy-Duty Horizontal Handle								X	X	X
Vertical Handle	X	X	X	X	X	X	X			
Heavy-Duty Vertical Handle						X	X	X	X	X
Vertical Handle, Cam Clamp							X			
Push/Pull		X	X	X	X	X		X	X	X
Latch				X	X		X		X	X
Pliers			X	X	X	X				
Air Powered		X	X		X	X	X		X	

TOGGLE CLAMP CONVERSION CHART

Reference Part No.	Carr Lane Part No.	Reference Part No.	Carr Lane Part No.	Reference Part No.	Carr Lane Part No.	Reference Part No.	Carr Lane Part No.
AO-100*	CL-1000-PTC	202943*	CL-14112-SA-S	240208*	CL-38314-FC	503*	CL-320-HVTC
AO-1200*	CL-3000-PTC	205-S	CL-150-HTC	245-S	CL-600-HTC	503-B*	CL-310-HVTC
AO-200*	CL-1000-PTC	205-SB	CL-151-HTC	245-U	CL-650-HTC	503-LB*	CL-311-HVTC
AO-2000(HD)*	CL-3000-PTC	205-SL	CL-153-HTC	245943*	CL-12234-SA-S	505*	CL-520-HVTC
AO-400*	CL-2000-PTC	205-SR	CL-152-HTC	247-S	CL-750-VTC	505-B*	CL-510-HVTC
AO-800*	CL-2000-PTC	205-SSS	CL-150-HTC-S	247-SB	CL-751-VTC	505-LB*	CL-511-HVTC
C-800	CL-850-VTC	205-U	CL-250-HTC	247-U	CL-850-VTC	506*	CL-620-HVTC
GLBU1*	CL-111-HVTC	205-UB	CL-251-HTC	247-UB	CL-851-VTC	506-B*	CL-610-HVTC
GLBU1-AW-HW*	CL-101-HVTC	205-UL	CL-253-HTC	247109	CL-1213-TW	506-LB*	CL-611-HVTC
GLBU3*	CL-311-HVTC	205-UR	CL-252-HTC	247110	CL-113000-BR	507107	CL-51610-TW
GLBU3-AW-HW*	CL-301-HVTC	205-USS	CL-250-HTC-S	250*	CL-800-VTC	507206*	CL-516212-SF
GLBU5*	CL-511-HVTC	205105	CL-142000-BR	250-G	CL-800-VTC	507208	CL-516212-FC
GLBU5-AW-HW*	CL-501-HVTC	205203	CL-14112-SA	250121*	CL-113000-BR	507907	CL-51610-TW-S
GLBU6*	CL-611-HVTC	205943*	CL-83234-SA-S	250203	CL-58438-SA	509208	CL-516212-CC
GLBU6-AW-HW*	CL-601-HVTC	206-HSS*	CL-51-TC	250206*	CL-44-SSC	527208	CL-38314-FC
GU1*	CL-120-HVTC	206-SS*	CL-51-TC	258*	CL-801-VTC	548*	CL-501-HVTC
GU1-B*	CL-110-HVTC	207-L	CL-353-VTC	258-G	CL-801-VTC	578*	CL-601-HVTC
GU3*	CL-320-HVTC	207-LB*	CL-351-VTC	267	CL-950-VTC	588*	CL-601-HVTC
GU3-B*	CL-310-HVTC	207-LR*	CL-350-LVTC	267-U	CL-1050-VTC	6001-M	CLM-60-SPC
GU5*	CL-520-HVTC	207-S	CL-350-VTC	267102	CL-5811-TW	6001-MMS*	CLM-60-SPC
GU5-B*	CL-510-HVTC	207-SB	CL-351-VTC	301	CL-150-PA	601*	CL-50-SPC
GU6*	CL-620-HVTC	207-TL*	CL-352-VTC	301-SS	CL-150-PA-S	601-0*	CL-51-SPC
GU6-B*	CL-610-HVTC	207-TS	CL-352-VTC	305-U	CL-200-VTC	601-M*	CLM-50-SPC
H-100	CL-250-HTC	207-TU	CL-452-VTC	305-UR*	CL-200-LVTC	601-SS*	CL-50-SPC-S
H-200	CL-350-HTC	207-TUL*	CL-452-VTC	305-USS	CL-200-VTC-S	6015	CL-100-SPC
H-200(SS)	CL-350-HTC-S	207-U	CL-450-VTC	305203*	CL-316112-SA	6015-M	CLM-100-SPC
H-400*	CL-450-HTC	207-UB	CL-451-VTC	305208	CL-316112-CC	6015-MR	CLM-100-LSPC
H-400(B)	CL-450-HTC	207-UL	CL-453-VTC	307-U	CL-300-VTC	6015-MRSS*	CL-100-LSPC-S
H-400(SS)*	CL-450-HTC-S	207-ULB*	CL-451-VTC	307-UR*	CL-300-LVTC	6015-R	CL-100-LSPC
H-600	CL-550-HTC	207-UR*	CL-450-LVTC	307-USS	CL-300-VTC-S	6015-RSS	CL-100-LSPC-S
H-600(SS)	CL-550-HTC-S	207105	CL-518000-BR	309-U	CL-500-VTC	6015-SS	CL-100-SPC-S
LUP-1203	CL-450-PL	207203	CL-516212-SA	309-UR*	CL-500-LVTC	602	CL-150-TPC
LUP-800	CL-254-PL	207206	CL-14200-SF	309-USS	CL-500-VTC-S	602-M	CLM-150-TPC
LUP-800-2S	CL-254-PL-2	207943*	CL-516212-SA-S	311	CL-170-PA	602-SS	CL-150-TPC-S
P-1200	CL-250-PL	210-S	CL-550-VTC	317	CL-375-HTC	603*	CL-100-PC
P-1203	CL-450-PL	210-SB	CL-551-VTC	317-U	CL-475-HTC	603-M*	CLM-100-PC
P-400*	CL-50-PL	210-SR*	CL-550-LVTC	323*	CL-100-PA	603-MR	CL-100-LPC
P-400-1*	CL-50-PL	210-TS	CL-552-VTC	323-MSS*	CL-100-PA-S	603-MR	CL-100-LPC
P-400-2*	CL-50-PL-2	210-TU	CL-652-VTC	323-SS	CL-100-PA-S	604	CL-250-TPC
P-400-2S*	CL-50-PL-3	210-U	CL-650-VTC	324*	CL-110-PA	604-M	CLM-250-TPC
P-800	CL-254-PL	210-UB	CL-651-VTC	324-SS*	CL-110-PA-S	604-SS	CL-250-TPC-S
P-800-2S	CL-254-PL-2	210-UR*	CL-650-LVTC	325	CL-325-PL-S	604106	CL-250-TPCA
PCH-101	CL-250-PA	210-USS	CL-650-VTC-S	325-SS	CL-325-PL-S	604T06	CL-150-SPC
PCH-101(SS)	CL-250-PA-S	210114	CL-316000-BR	325203*	CL-12314-SA	605-M	CLM-150-SPC
PCH-200	CL-250-PA	210203*	CL-38314-SA	331*	CL-200-PA	607*	CL-350-SPC
PH & PL-1600	CL-250-PL	210206	CL-38314-SF	331-R*	CL-200-LPA	608	CL-200-PC
S-100	CL-251-VTC	210208	CL-38314-CC	331-R-SS*	CL-200-LPA-S	610*	CL-250-SPC
S-200*	CL-451-VTC	211208*	CL-14200-CC	331-SS*	CL-200-PA-S	610-M*	CLM-250-SPC
S-400*	CL-651-VTC	213-U*	CL-260-HTC	334*	CL-210-PA	620*	CL-275-SPC
T-100	CL-252-VTC	213-USS*	CL-260-HTC-S	334-SS*	CL-210-PA-S	620-M*	CLM-275-SPC
T-200	CL-452-VTC	213208	CL-14200-CC	341*	CL-300-PA	624	CL-350-TPC
T-400	CL-652-VTC	213943	CL-832203-SA-S	341-R*	CL-300-LPA	624-M	CLM-350-TPC
V-100	CL-250-VTC	215-S	CL-300-HTC	341-R-SS*	CL-300-LPA-S	624-SS	CL-350-TPC-S
V-100(SS)	CL-250-VTC-S	215-U	CL-350-HTC	341-SS*	CL-300-PA-S	628*	CL-276-SPC
V-1200*	CL-1050-VTC	215-UB	CL-351-HTC	344*	CL-310-PA	630	CL-350-SPC
V-200*	CL-453-VTC	215-USS	CL-350-HTC-S	344-SS*	CL-310-PA-S	630-M	CLM-350-SPC
V-200(SS)*	CL-450-VTC-S	215105*	CL-148-TW	345	CL-345-PL	630-MR*	CL-350-LPC
V-400*	CL-650-VTC	215208	CL-14200-FC	345100	CL-345-PLA	630-M	CL-350-LPC
V-400(SS)*	CL-650-VTC-S	215905*	CL-148-TW-S	351	CL-250-PA	640*	CL-450-SPC
VC-200*	CL-350-VTC	217-U*	CL-350-HTC	351-B	CL-251-PA	640-M*	CLM-450-SPC
VC-400*	CL-550-VTC	217-USS*	CL-350-HTC-S	351-R*	CL-257-PA	650	CL-650-SPC
102111	CL-3166-TW	220	CL-600-VTC	351-SS	CL-250-PA-S	650-M	CLM-650-SPC
102208	CL-832208-FC	220203	CL-12314-SA	375	CL-400-PA	7-59	CL-1000-VCC
102911	CL-3166-TW-S	220208*	CL-38314-CC	375-R	CL-400-LPA	802*	CL-500-PTC
105106	CL-832-TW	225-U	CL-450-HTC	381	CL-350-PA	803*	CL-1500-PPC
105203	CL-832203-SA	225-UB	CL-451-HTC	385	CL-500-PA	807-L*	CL-1001-PTC
105208*	CL-832208-FC	225-UR*	CL-451-HTC	385-R	CL-500-LPA	807-LH/T*	CL-1001-PTCH
105906	CL-832-TW-S	225-USS	CL-450-HTC-S	385102	CL-500-PAA	807-UL*	CL-1000-PTC
110122	CL-511000-BR	225208	CL-518208-FC	424	CL-50-PL	807-ULH/T*	CL-1000-PTCH
201	CL-150-VTC	227-U*	CL-450-HTC	424-2	CL-50-PL-2	810-S*	CL-2001-PTC
201-B	CL-151-VTC	227-USS*	CL-450-HTC-S	424208	CL-14208-SA	810-U*	CL-2000-PTC
201-SS	CL-150-VTC-S	227943*	CL-516212-SA-S	431208	CL-14100-SA	812*	CL-400-PTC
201-T	CL-152-VTC	228	CL-601-VTC	441	CL-150-PL	816*	CL-600-PPC
201208	CL-316112-FC	235-U	CL-550-HTC	441203*	CL-516212-SA	847-S*	CL-2001-PTC
201943	CL-316100-SA-S	235-UB	CL-551-HTC	462	CL-254-PL	847-U*	CL-2000-PTC
202	CL-250-VTC	235-UR*	CL-550-HTC	462-2	CL-254-PL-2	858*	CL-3000-PTC
202-B	CL-251-VTC	235-USS	CL-550-HTC-S	463	CL-454-PL	870*	CL-1011-POC
202-SS	CL-250-VTC-S	235106	CL-3811-TW	468	CL-254-PL	871*	CL-1010-POC
202-T	CL-252-VTC	235906	CL-3811-TW-S	468206*	CL-38314-SF	902*	CL-516212-SL
202-U*	CL-253-VTC	237-U*	CL-550-HTC	474	CL-454-PL	904*	CL-38314-SL
202-USS	CL-253-VTC-S	237-USS*	CL-550-HTC-S	486*	CL-550-PL		
202203*	CL-14200-SA	237943*	CL-38314-SA-S	501*	CL-120-HVTC		
202208	CL-14112-FC	240203*	CL-38314-SA	501-B*	CL-110-HVTC		

* Functionally equivalent, but differs in some dimension and/or specification. Please check catalog before ordering.

HORIZONTAL-HANDLE TOGGLE CLAMPS

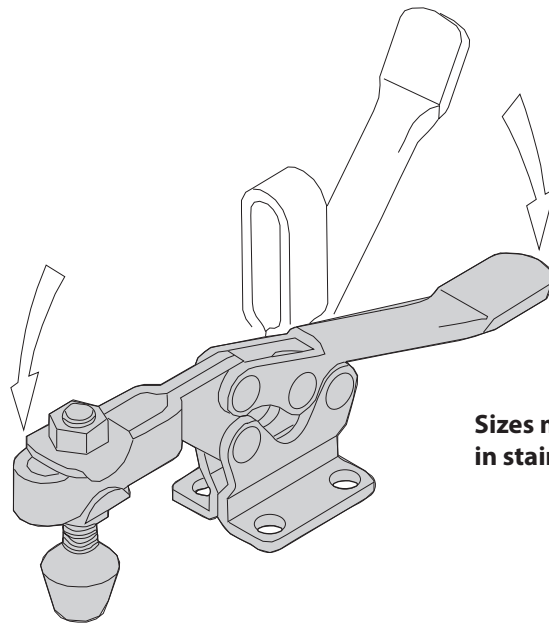

Sizes marked * are also available in stainless steel.

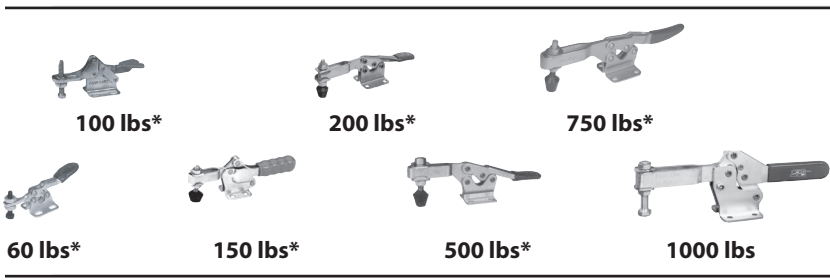

Standard HTC Design p. 443-447

Most-popular and widest-range series of horizontal-handle hold-down clamps. Available in seven sizes, the smaller ones with a comfortable finger grip. Most sizes are available with either a flanged base or a straight base. Choice of solid arm, or open arm for spindle adjustment.

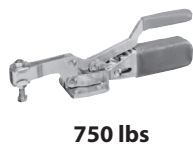

Automatically Adjusting p. 448

Self-adjusting clamp automatically compensates for different workpiece heights without resetting the spindle. Clamping force is always consistent after setting once.



Low-Arm TC Design p. 449

Simple, classic-design horizontal-handle clamps. Available in three sizes, with either a flanged base or a straight base.



Extra-Wide Opening p. 450

Arm opens a full 185° for maximum loading clearance. Unique up-then-down handle motion. Handle locks at a 60° downward angle. Dual flanged bases allow mounting on either horizontal or vertical surfaces. Choice of solid arm, or open arm for spindle adjustment.

HORIZONTAL-HANDLE TOGGLE CLAMPS

INFO+: SEE PAGE 439 FOR MATERIAL SPECIFICATIONS

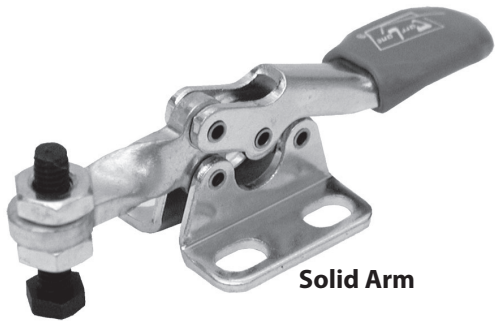

Solid Arm



Open Arm

CL-150-HTC Solid Arm, Flanged Base

CL-250-HTC Open Arm, Flanged Base

Smallest hold-down clamp available. Choose either a solid arm, or an open arm for spindle adjustment. Arm opens 90° while handle moves 80°. Supplied with #8-32 nylon hex-head spindle CL-832203-5A. Open-arm versions also include (2) CL-832-TW flanged washers. Shipping weight 0.1 lbs.

Holding capacity: 60 lbs

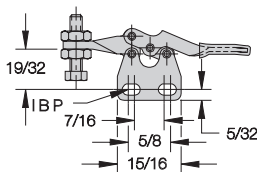
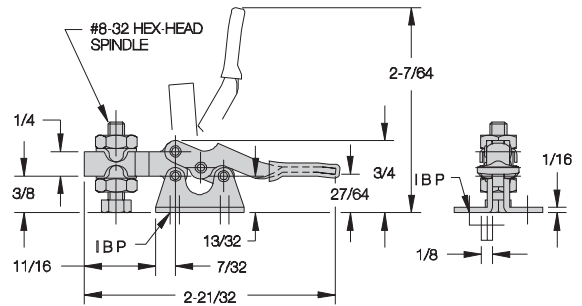
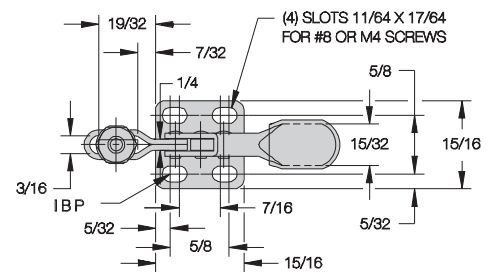
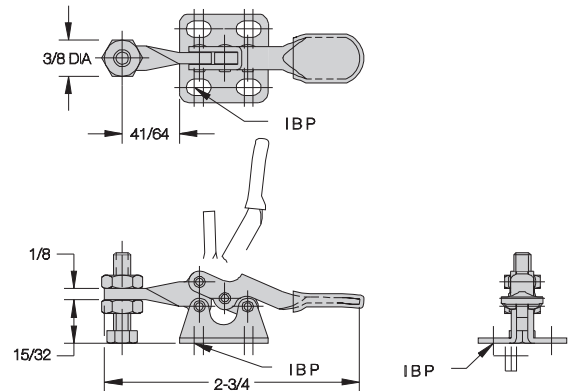

CL-151-HTC
Solid Arm
Straight Base

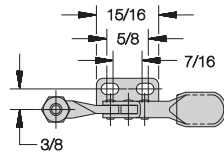

CL-152-HTC
Solid Arm
Right Flange

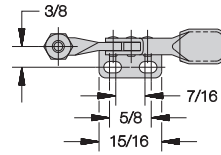

CL-153-HTC
Solid Arm
Left Flange

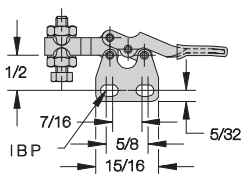

CL-251-HTC
Open Arm
Straight Base

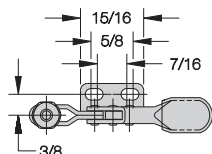

CL-252-HTC
Open Arm
Right Flange

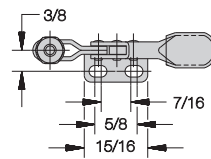

CL-253-HTC
Open Arm
Left Flange

Also available in stainless steel...



CL-150-HTC-S



CL-250-HTC-S

HORIZONTAL-HANDLE TOGGLE CLAMPS

INFO+: SEE PAGE 439 FOR MATERIAL SPECIFICATIONS

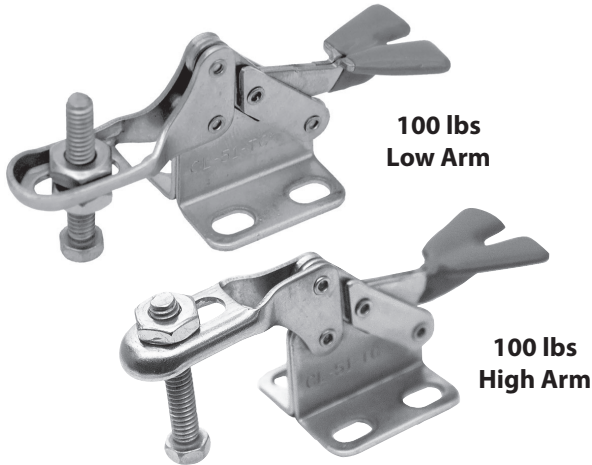

**100 lbs
Low Arm**

**100 lbs
High Arm**

CL-51-TC

Low Arm, Flanged Base

CL-53-TC

High Arm, Flanged Base

Miniature stainless steel clamp with open arm for spindle adjustment. Perfect for electronics fixturing and other light-duty application. Arm opens 90° while handle moves 90°. Supplied with #8-32 stainless hex-head spindle CL-832203-SA-S. Shipping weight 0.1 lbs.

Holding capacity: 100 lbs

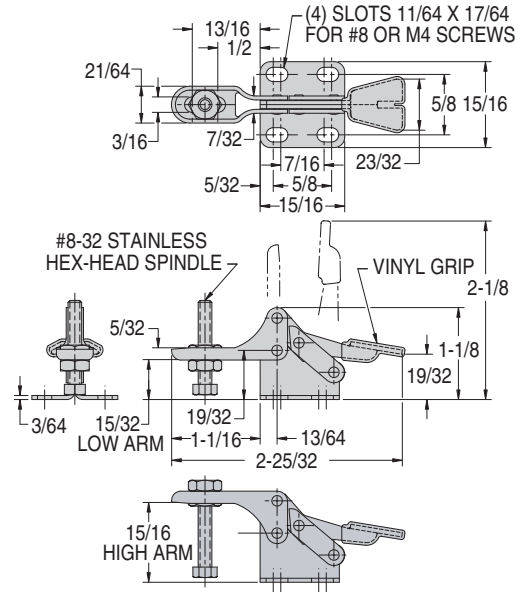

HORIZONTAL-HANDLE TOGGLE CLAMPS

INFO+: SEE PAGE 439 FOR MATERIAL SPECIFICATIONS

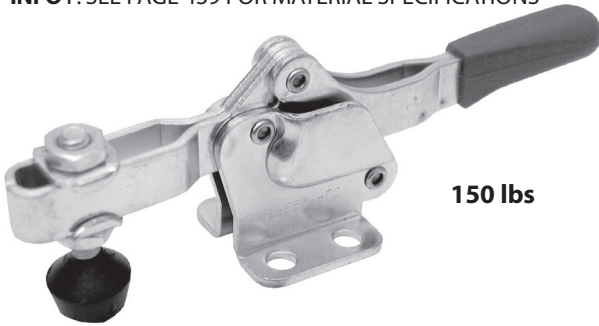

150 lbs

CL-260-HTC

Open Arm, Flanged Base

An extremely powerful clamp for its small size. Open arm allows spindle adjustment. Arm opens 90° while handle moves 75°. Supplied with #10-32 flat-cushion spindle CL-316112-FC and (2) CL-3166-TW flanged washers. Shipping weight 0.2 lbs.

Holding capacity: 150 lbs

Also available in stainless steel...



CL-260-HTC-S

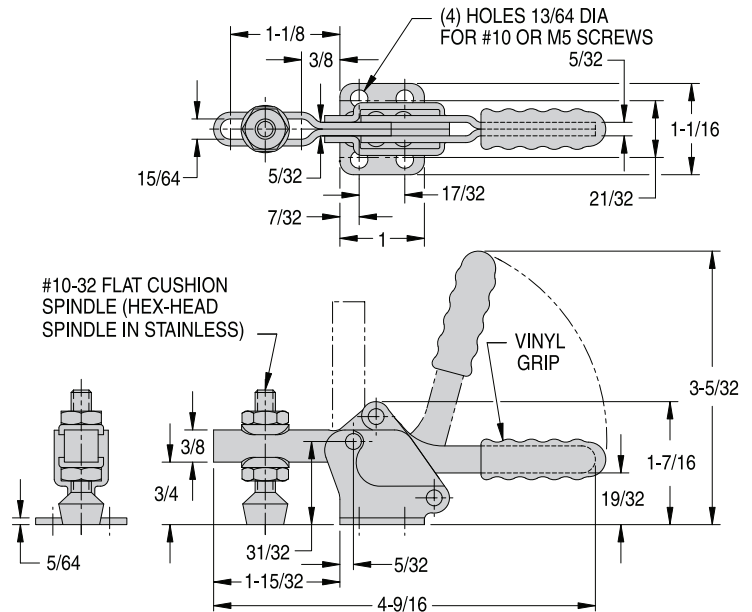

HORIZONTAL-HANDLE TOGGLE CLAMPS

INFO+: SEE PAGE 439 FOR MATERIAL SPECIFICATIONS

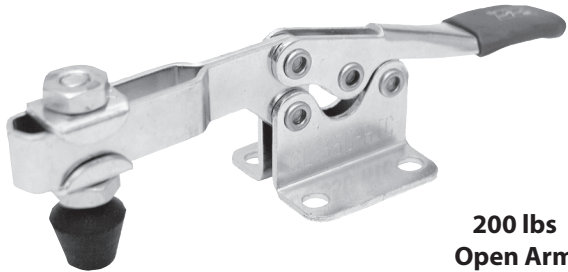

**200 lbs
Open Arm**

CL-350-HTC **Open Arm, Flanged Base**

Popular medium-duty clamp with an open arm for spindle adjustment. Arm opens 86° while handle moves 60°. Supplied with 1/4-20 short flat-cushion spindle CL-14112-FC and (2) CL-147-TW flanged washers. Shipping weight 0.3 lbs.

Holding capacity: **200 lbs**

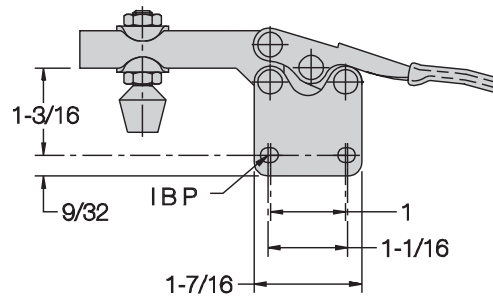
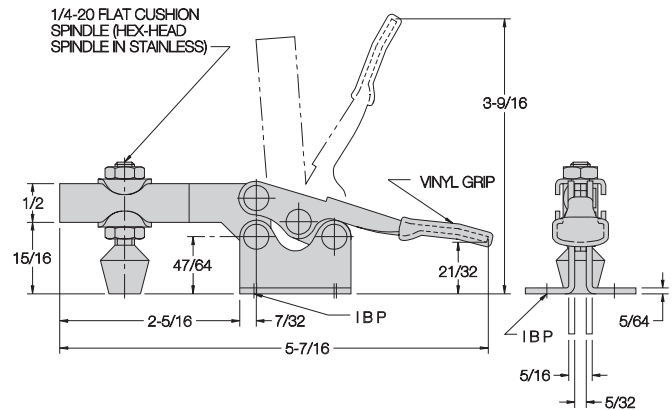
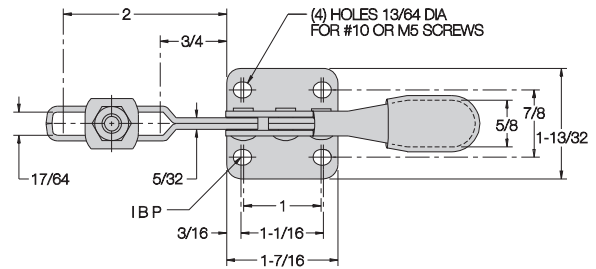

**CL-351-HTC
Open Arm
Straight Base**

Also available in stainless steel...



CL-350-HTC-S

HORIZONTAL-HANDLE TOGGLE CLAMPS

INFO+: SEE PAGE 439 FOR MATERIAL SPECIFICATIONS

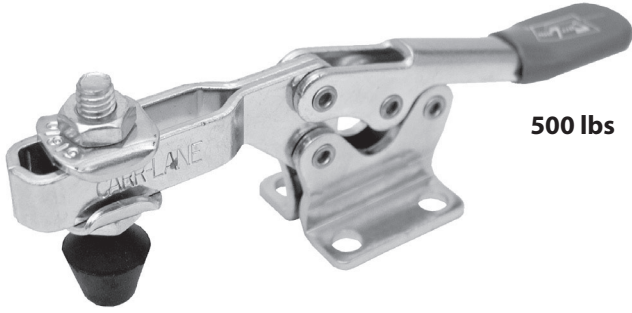

500 lbs

CL-450-HTC

Open Arm, Flanged Base

Strong-yet-compact horizontal-handle clamp, with open arm for spindle adjustment. Arm opens 90° while handle moves 65°. Supplied with 5/16-18 short flat-cushion spindle CL-518208-FC and (2) CL-51610-TW flanged washers. Shipping weight 0.6 lbs.

Holding capacity:

500 lbs

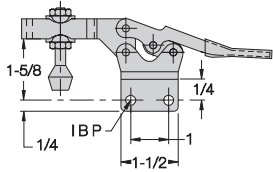

CL-451-HTC
Straight Base

Also available in stainless steel...



CL-450-HTC-S

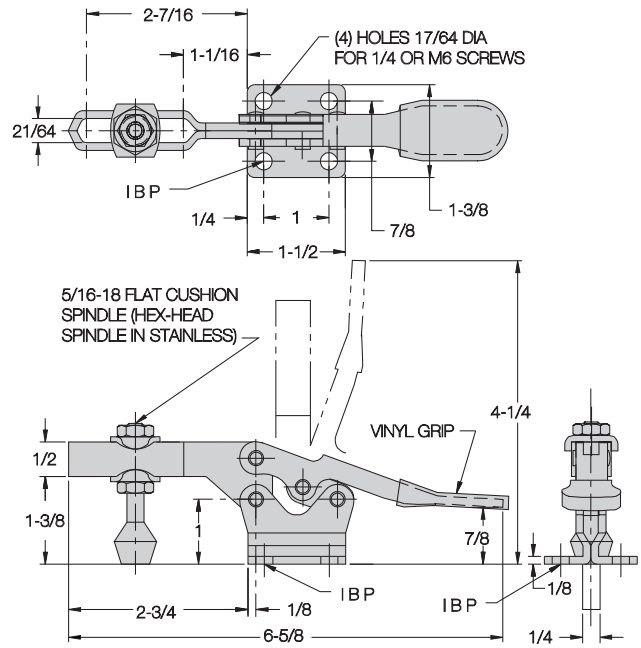

HORIZONTAL-HANDLE TOGGLE CLAMPS

INFO+: SEE PAGE 439 FOR MATERIAL SPECIFICATIONS

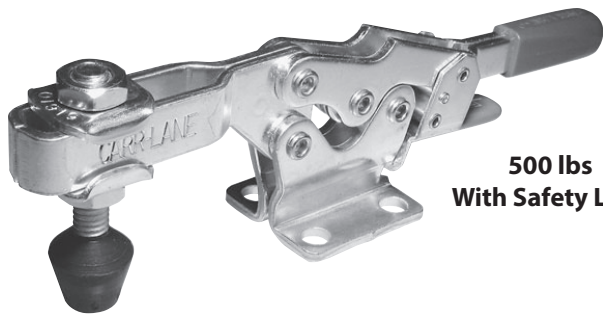

500 lbs
With Safety Lock

CL-450-LHTC

Open Arm, Flanged Base

Same as the toggle clamp shown above, except with our unique safety-lock feature. This safety lock automatically engages when the clamp is closed, then remains locked until manually disengaged by pressing the lever before opening. This prevents the clamp from being accidentally opened by bumping the handle. Shipping weight 0.7 lbs.

Holding capacity:

500 lbs

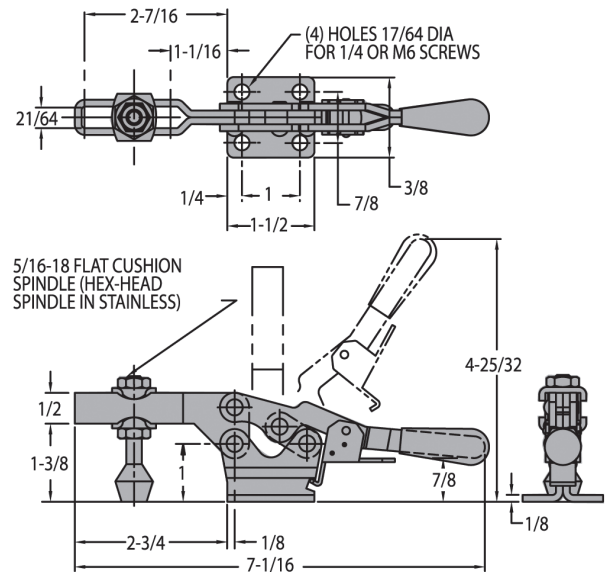
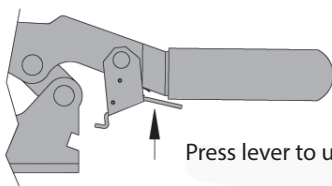

HORIZONTAL-HANDLE TOGGLE CLAMPS

INFO+: SEE PAGE 439 FOR MATERIAL SPECIFICATIONS

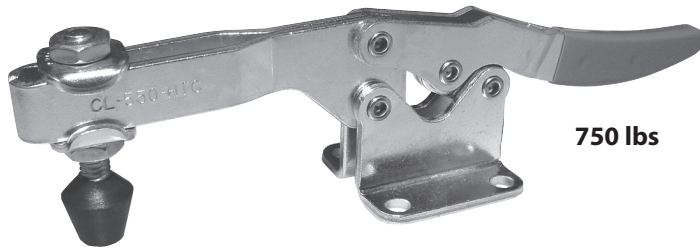

750 lbs

CL-550-HTC Open Arm, Flanged Base

Heavy-duty clamp with open arm for spindle adjustment. Arm opens 90° while handle moves 55°. Supplied with 3/8-16 short flat-cushion spindle CL-38212-FC and (2) CL-3811-TW flanged washers. Shipping weight 1.5 lbs.

Holding capacity:

750 lbs

Also available in stainless steel...



CL-550-HTC-S

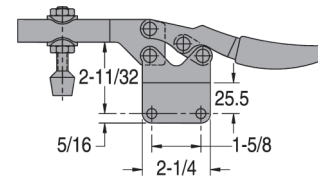
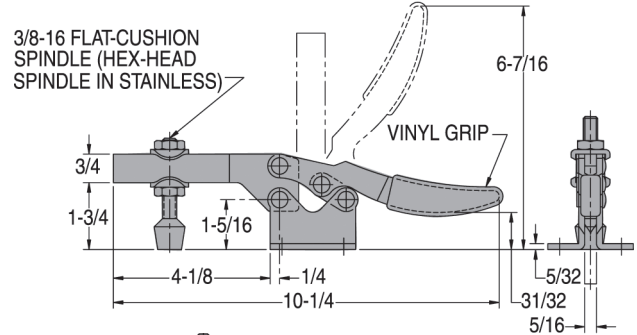
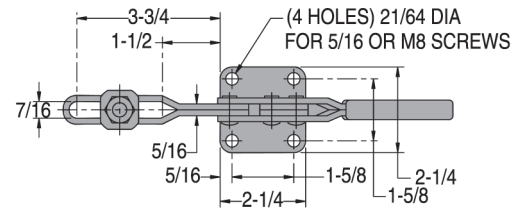

CL-551-HTC
Straight Base

HORIZONTAL-HANDLE TOGGLE CLAMPS

INFO+: SEE PAGE 439 FOR MATERIAL SPECIFICATIONS

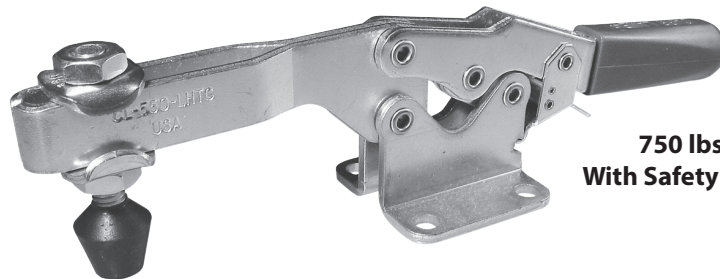

750 lbs
With Safety Lock

CL-550-LHTC Open Arm, Flanged Base

Same as the toggle clamp shown above, except with our unique safety-lock feature. This safety lock automatically engages when the clamp is closed, then remains locked until manually disengaged by pressing the lever before opening. This prevents the clamp from being accidentally opened by bumping the handle. Shipping weight 1.6 lbs.

Holding capacity:

750 lbs

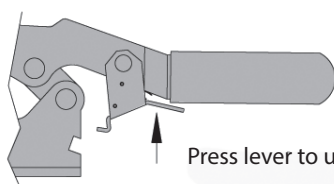

Press lever to unlock.

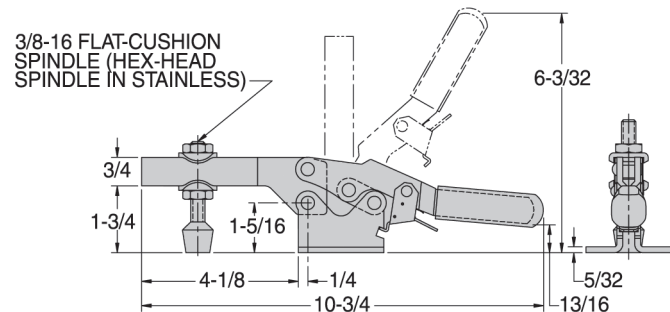
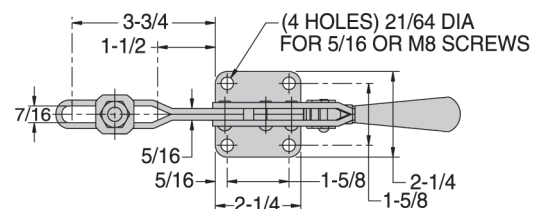

HORIZONTAL-HANDLE TOGGLE CLAMPS

INFO+: SEE PAGE 439 FOR MATERIAL SPECIFICATIONS

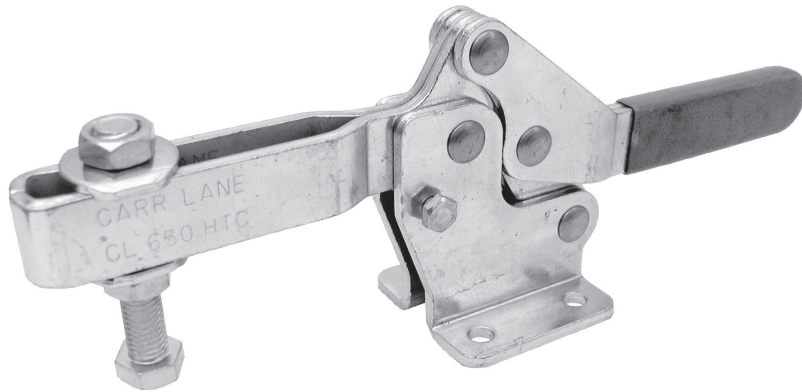

**1000 lbs
Open Arm**

CL-650-HTC Open Arm, Flanged Base

Largest and strongest horizontal-handle hold-down clamp with an open arm for spindle adjustment. Arm opens a wide 105° while handle moves 75°. Supplied with 1/2-13 hex-head spindle CL-12314-SA and (2) CL-1213-TW flanged washers. Shipping weight 3.3 lbs.

Holding capacity: **1000 lbs**

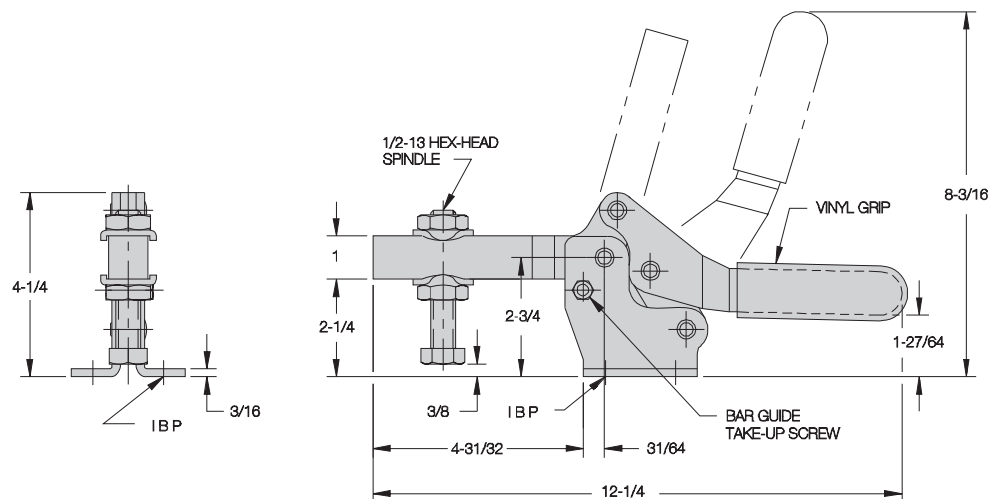
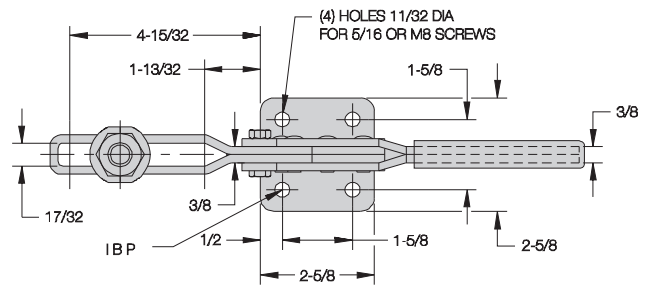

HORIZONTAL-HANDLE TOGGLE CLAMPS

INFO+: SEE PAGE 439 FOR MATERIAL SPECIFICATIONS

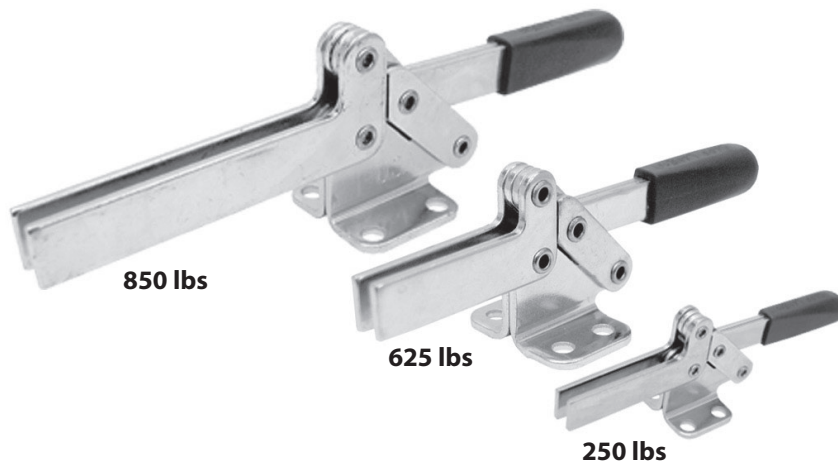

Classic-design horizontal-handle clamps with open arm for spindle adjustment. Arm opens 90° while handle moves 90°. Available in three sizes.

CL-151-TC Open Arm, Flanged Base

Smallest-size clamp. Accepts any #10-32 spindle and (2) CL-3166-TW flanged washers. For fixed spindle location, use a 1/4-20 spindle and a CL-1458-S bolt retainer.

Holding capacity: 250 lbs

CL-251-TC Open Arm, Flanged Base

Medium-size clamp. Accepts any 1/4-20 spindle and (2) CL-148-TW flanged washers. For fixed spindle location, use a CL-1458-S bolt retainer.

Holding capacity: 625 lbs

CL-351-TC Open Arm, Flanged Base

Largest-size clamp. Accepts any 5/16-18 spindle and (2) CL-51610-TW flanged washers. For fixed spindle location, use a CL-51658-S bolt retainer.

Holding capacity: 850 lbs

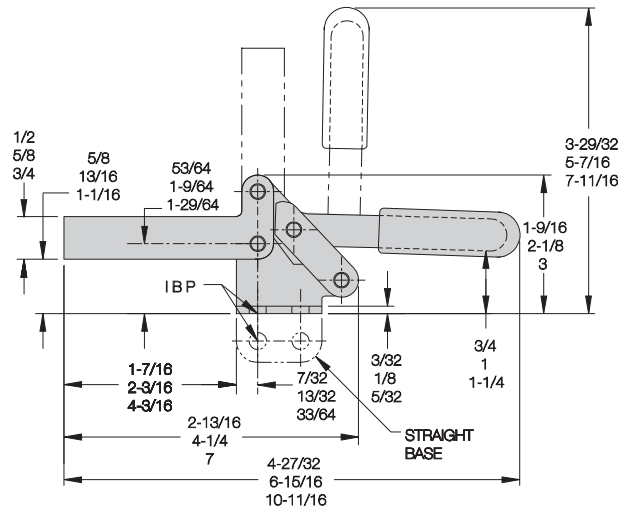
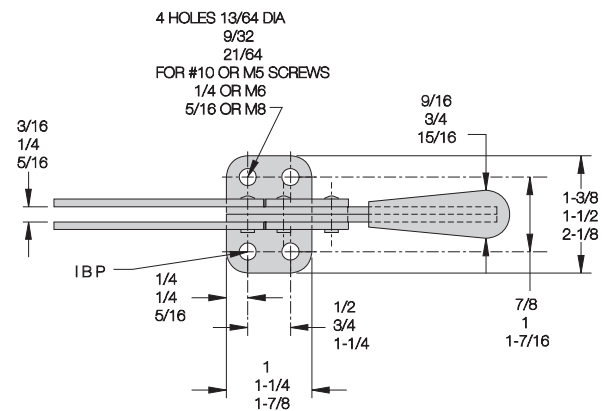

CL-151-TC (Top dimension)
CL-251-TC (Middle dimension)
CL-351-TC (Bottom dimension)

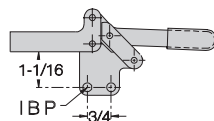

CL-252-TC
Straight Base
625 lbs

HORIZONTAL-HANDLE TOGGLE CLAMPS

INFO+: SEE PAGE 439 FOR MATERIAL SPECIFICATIONS

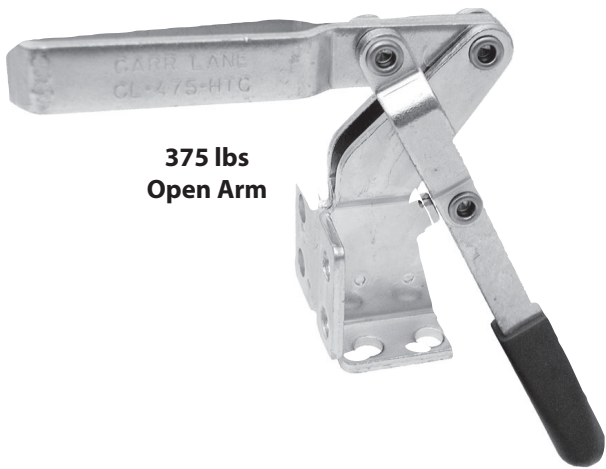

**375 lbs
Open Arm**

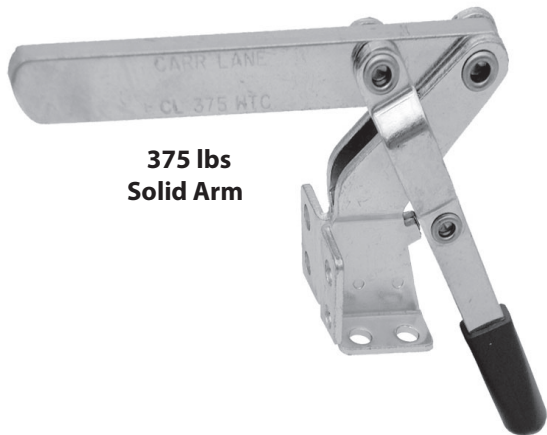

**375 lbs
Solid Arm**

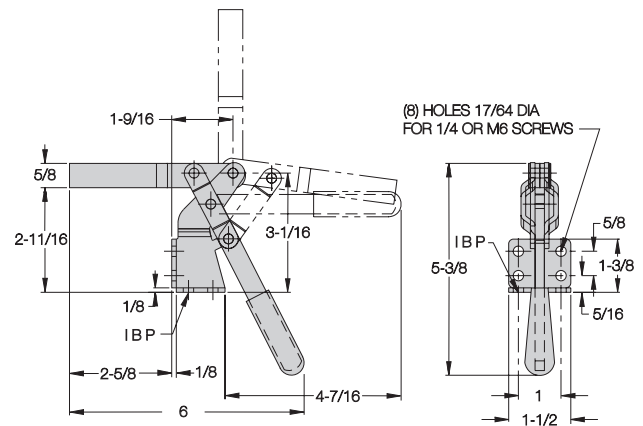
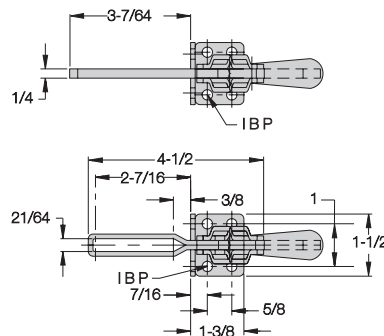
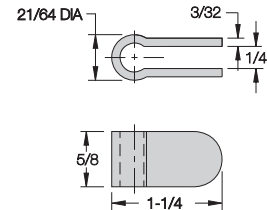

CL-375-HTC

Solid Arm

CL-475-HTC

Open Arm

Extra-wide-opening clamp with handle that locks at a downward angle. Unique up-then-down handle motion opens arm a full 185°. Dual flanged bases allow mounting on either horizontal or vertical surfaces. Available with a solid arm, or an open arm for spindle adjustment. Accepts all 5/16-18 spindles. INFO+: See pages 522-526 to order. Solid-arm version supplied with a CL-518000-BR bolt retainer. Open-arm version supplied with (2) CL-51610-TW flanged washers. Shipping weight 0.8 lbs.

Holding capacity:

375 lbs

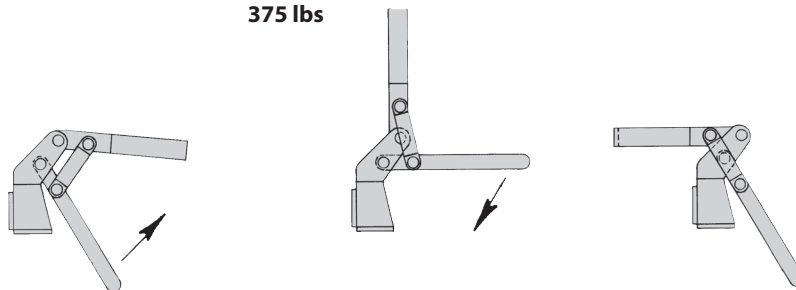

VERTICAL-HANDLE TOGGLE CLAMPS

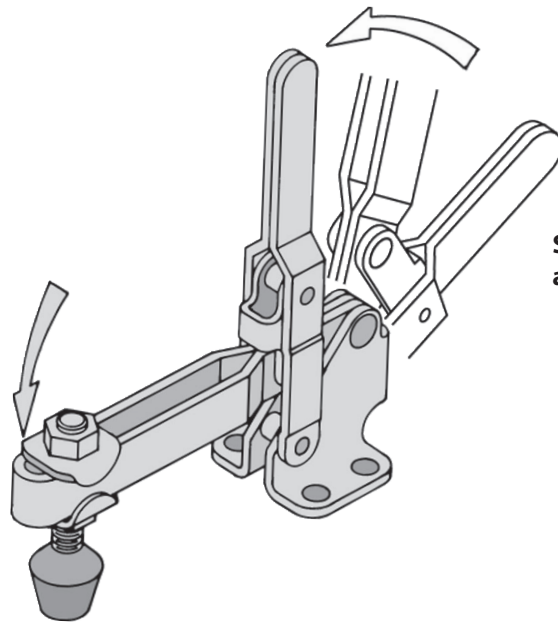

Sizes marked * are also available in stainless steel



Wide Opening p. 453-456

Clamping arm opens past 90° for excellent loading clearance. Most-popular and widest-range series of vertical-handle hold-down clamps. Choice of flanged or straight base, solid or open arm, and regular or T handle in most of the seven available sizes.



Wide Opening – Angle Arm p. 457

Clamps with arm tilted upward for increased clearance underneath. Also useful for applying clamping force at an angle. Wide-opening solid arm. Choice of flanged base or straight base. Available in two sizes.



Wide Opening Automatically Adjusting p. 465

Self-adjusting clamp automatically compensates for different workpiece heights without resetting the spindle. Clamping force is always consistent. Wide opening.

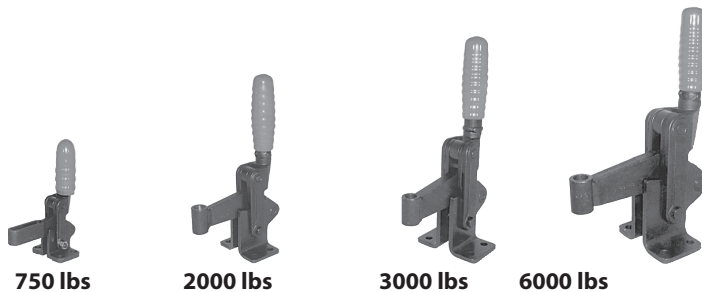

Wide Opening – Heavy-Duty p. 466-467

Heavy-duty production clamps designed for extreme durability. Available either as complete clamps or as basic mechanisms for adding custom clamping arms or handles. Choice of four sizes.

CONTINUED ON NEXT PAGE

VERTICAL-HANDLE TOGGLE CLAMPS

CONTINUED FROM PREVIOUS PAGE



150 lbs*



350 lbs*



750 lbs*

Low Profile p. 470-471

Extremely compact low-profile clamps with a unique finger-grip T handle. Available in three sizes.



100 lbs*



250 lbs



625 lbs



850 lbs

Low Arm p. 473-475

Simple, easy-opening clamps with excellent arm reach. Extends farther over workpiece than any clamp its size. Choice of flanged or straight base, and solid or open arm. Arm opens 83°. Available in seven sizes, the largest three forged.



1500 lbs



2500 lbs



5000 lbs



100 lbs*



250 lb



625 lbs



850 lbs

High Arm p. 472, 474

Simple, easy-opening clamps with extra arm height. Choice of flanged or straight base, and solid or open arm. Arm opens 83°. Available in seven sizes, the largest three forged.



1500 lbs



2500 lbs



5000 lbs

Vertical Handle Cam Clamps p. 464

Wide-opening clamp that locks by spiral-cam action rather than toggle action. Solid arm, flanged base.



1000 lbs

VERTICAL-HANDLE TOGGLE CLAMPS

INFO+: SEE PAGE 439 FOR MATERIAL SPECIFICATIONS

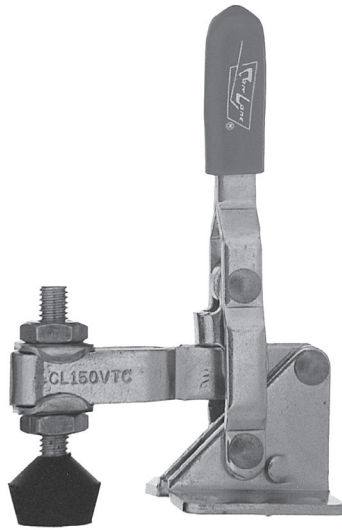

CL-150-VTC Open Arm, Flanged Base

Smallest wide-opening hold-down clamp available. Open arm provides adjustable spindle location. Arm opens 100° while handle moves 56°. Supplied with #10-32 flat-cushion spindle CL-316112-FC and (2) CL-3166-TW flanged washers. Shipping weight 0.2 lbs.

Holding capacity: 100 lbs

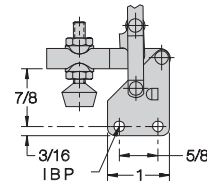
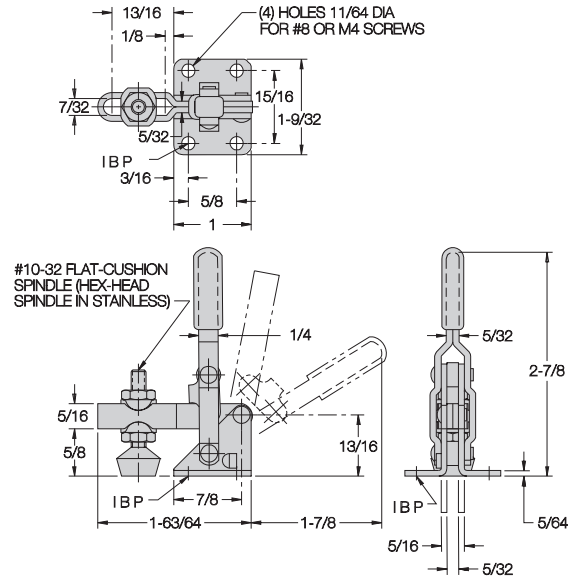

CL-151-VTC Straight Base

Also available in stainless steel...

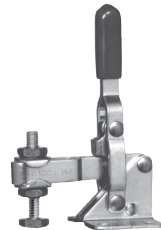

CL-150-VTC-S

Also available air powered...

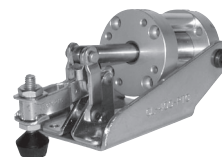

CL-400-PTC

VERTICAL-HANDLE TOGGLE CLAMPS

INFO+: SEE PAGE 439 FOR MATERIAL SPECIFICATIONS

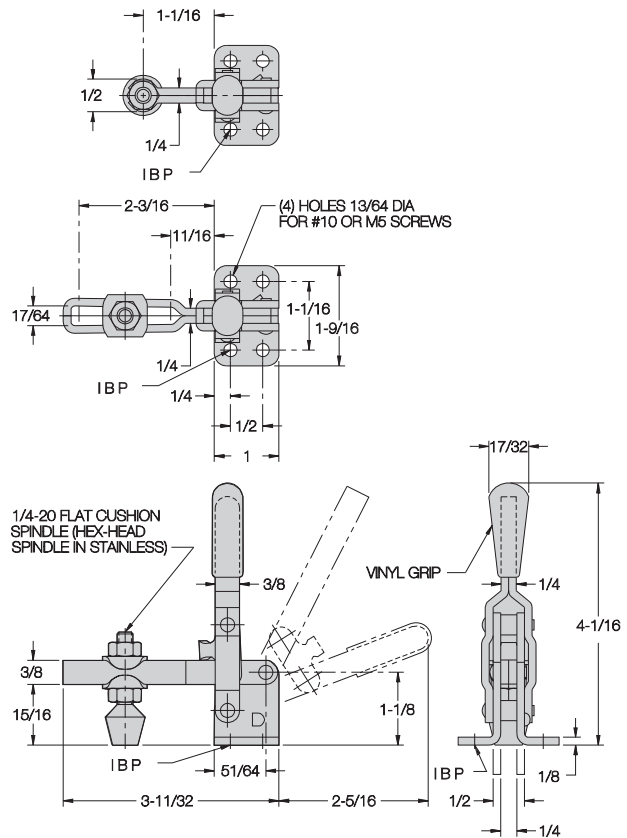
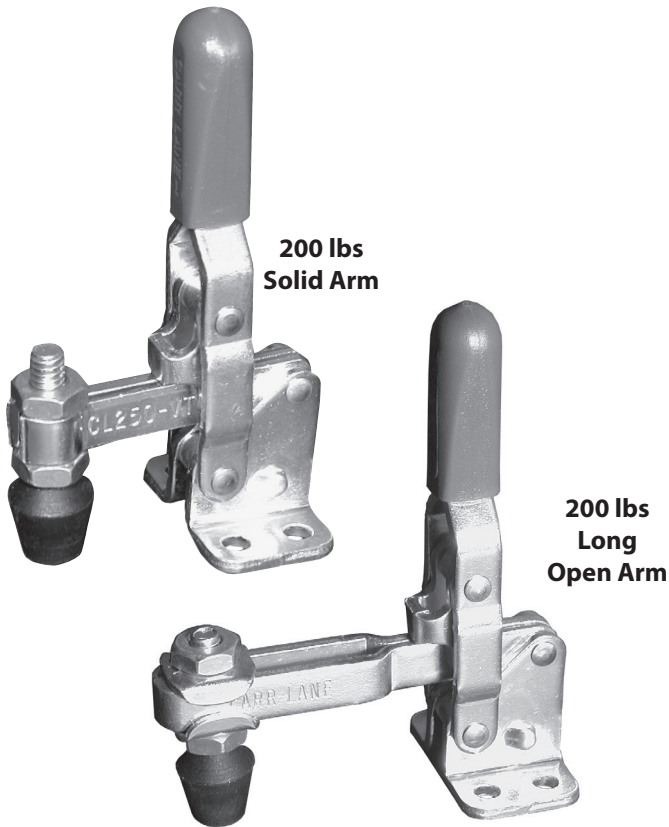

CL-250-VTC CL-253-VTC

Solid Arm, Flanged Base

Open Arm, Flanged Base

Small-yet-powerful clamp available in several configurations. Choose either a solid arm, or a long open arm for spindle adjustment. Arm opens 117° while handle moves 69°. Supplied with 1/4-20 short flat-cushion spindle CL-14112-FC. Open-arm version supplied with (2) CL-148-TW flanged washers. Shipping weight 0.4 lbs.

Holding capacity:

200 lbs

Also available in stainless steel...

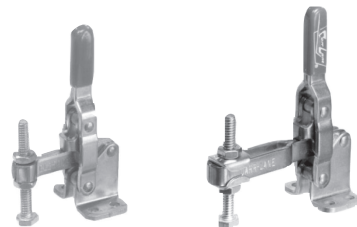

CL-250-VTC-S

CL-253-VTC-S

Also available air powered...



CL-500-PTC

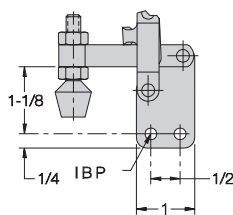

**CL-251-VTC
Solid Arm
Straight Base**

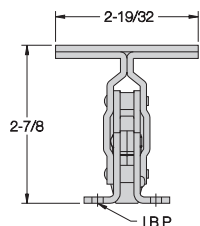

**CL-252-VTC
Solid Arm
Flanged Base
T Handle**

VERTICAL-HANDLE TOGGLE CLAMPS

INFO+: SEE PAGE 439 FOR MATERIAL SPECIFICATIONS

**200 lbs
Solid Arm
With Safety Lock**



**200 lbs
Long Open Arm
With Safety Lock**



CL-250-LVTC

Solid Arm, Flanged Base

CL-253-LVTC

Long, Open Arm, Flanged Base

INFO+: Same as the wide-opening toggle clamps shown on page 468, except with our unique safety-lock feature. This safety lock automatically engages when the clamp is closed, then remains locked until manually disengaged by pressing the handle. This prevents the clamp from being accidentally opened by bumping the handle.

Choose either a solid arm, or a long open arm for spindle adjustment. Arm opens 117° while handle moves 69°. Supplied with 1/4-20 short flat-cushion spindle CL-14112-FC. Open-arm version supplied with (2) CL-148-TW flanged washers. Shipping weight 0.4 lbs.

Holding capacity:

200 lbs

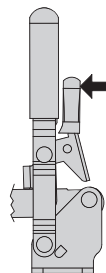

Press Lever To Unlock

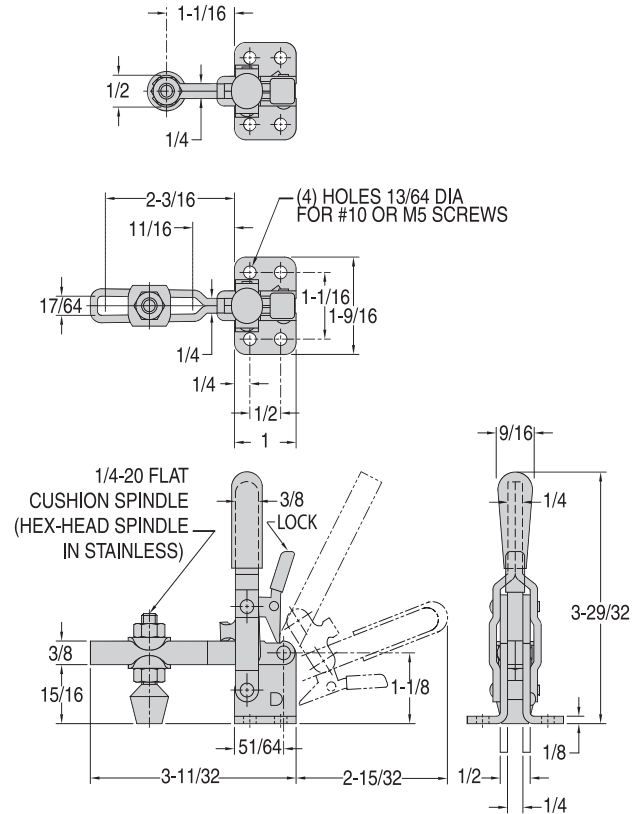

VERTICAL-HANDLE TOGGLE CLAMPS

INFO+: SEE PAGE 439 FOR MATERIAL SPECIFICATIONS



500 lbs
Solid Arm



500 lbs
Open Arm

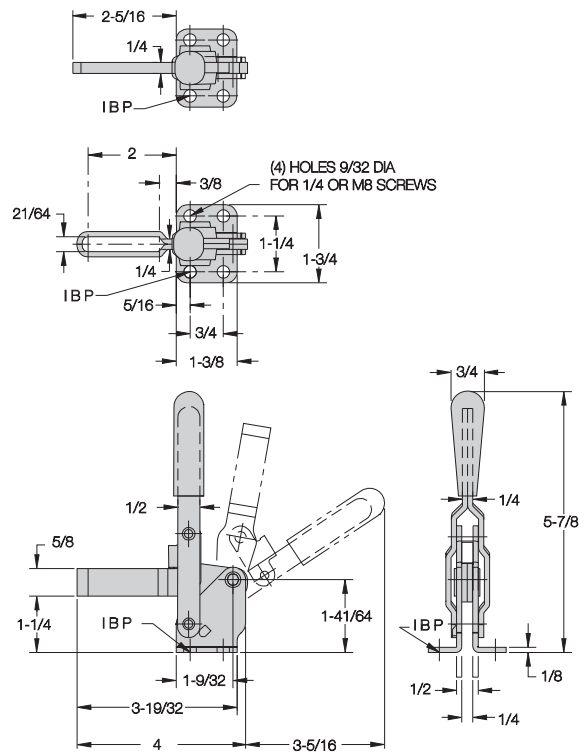

CL-350-VTC CL-450-VTC

Solid Arm, Flanged Base

Open Arm, Flanged Base

Most-popular wide-opening clamp available in many configurations. Choose either a solid arm, or an open arm for spindle adjustment (extra-long arms also available). Arm opens 100° while handle moves 60°. Accepts any 5/16-18 short spindle. Solid-arm versions supplied with a CL-518000-BR bolt retainer. Open-arm versions supplied with (2) CL-51610-TW flanged washers. Shipping weight 0.8 lbs.

Holding capacity:

500 lbs

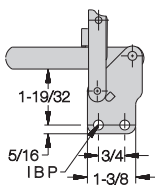

CL-351-VTC
Solid Arm
Straight Base

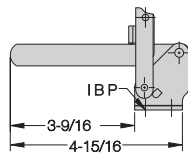

CL-353-VTC
Long Solid Arm
Flanged Base

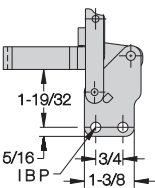

CL-451-VTC
Open Arm
Straight Base

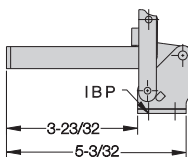

CL-453-VTC
Long Open Arm
Flanged Base

Also available
in stainless steel...



CL-450-VTC-S

Also available
air powered...

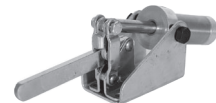

CL-1001-PTC
Solid Arm



CL-1000-PTC
Open Arm

VERTICAL-HANDLE TOGGLE CLAMPS

INFO+: SEE PAGE 439 FOR MATERIAL SPECIFICATIONS



CL-350-LVTC CL-450-LVTC

Solid Arm, Flanged Base

Open Arm, Flanged Base

INFO+: Same as the wide-opening toggle clamps shown on page 476, except with our unique safety-lock feature. This safety lock automatically engages when the clamp is closed, then remains locked until manually disengaged by pressing the handle. This prevents the clamp from being accidentally opened by bumping the handle.

Choose either a solid arm, or an open arm for spindle adjustment. Arm opens 100° while handle moves 60°. Accepts any 5/16-18 short spindle. Solid-arm version supplied with CL-518000-BR bolt retainer. Open-arm version supplied with (2) CL-51610-TW flanged washers. Shipping weight 0.9 lbs.

Holding capacity:

500 lbs

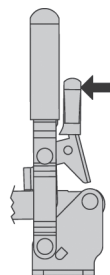
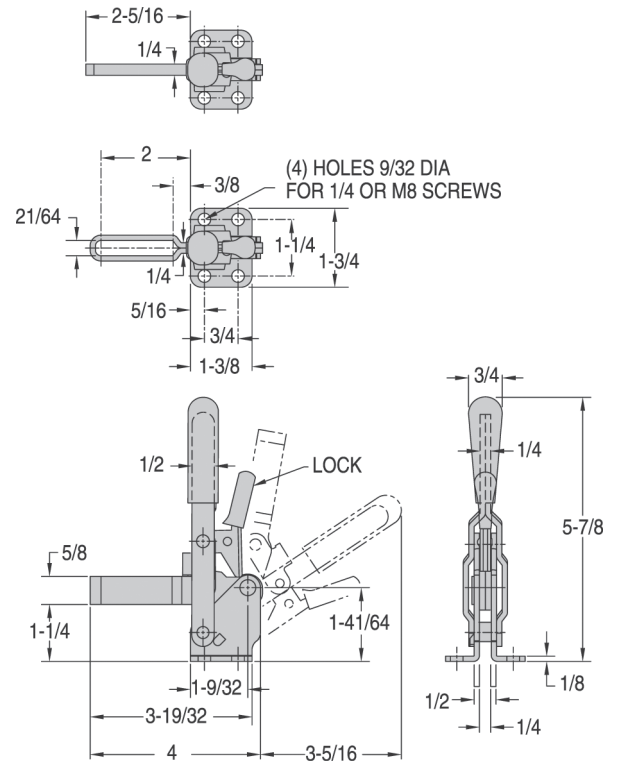

Press Lever to Unlock

Also available
in stainless steel...



CL-450-LVTC-S

VERTICAL-HANDLE TOGGLE CLAMPS

INFO+: SEE PAGE 439 FOR MATERIAL SPECIFICATIONS

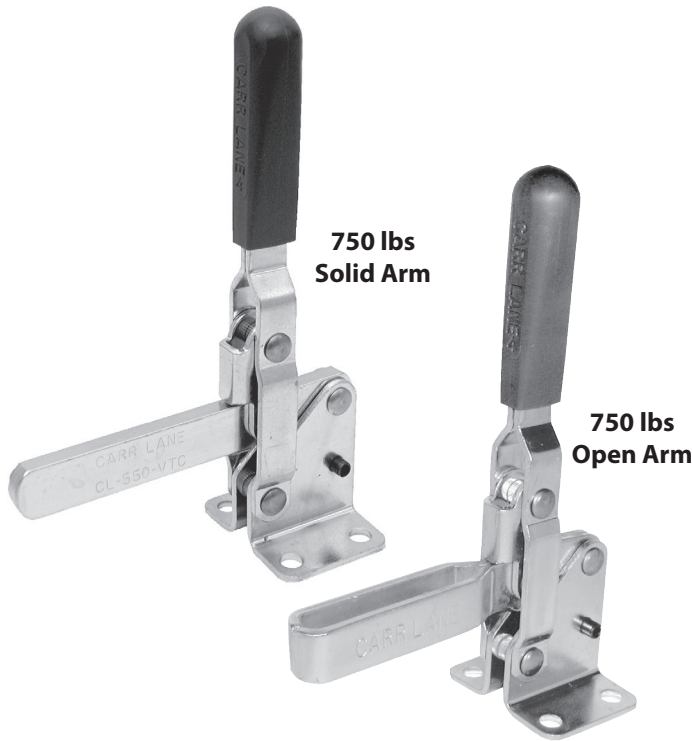

CL-550-VTC CL-650-VTC

Solid Arm, Flanged Base

Open Arm, Flanged Base

Larger wide-opening clamp available in several configurations. Choose either a solid arm, or an open arm for spindle adjustment. Arm opens 106° while handle moves 58°. Accepts any 3/8-16 spindle. Solid-arm version supplied with a CL-316000-BR bolt retainer. Open-arm version supplied with (2) CL-3811-TW flanged washers. Shipping weight 1.3 lbs.

Holding capacity:

750 lbs

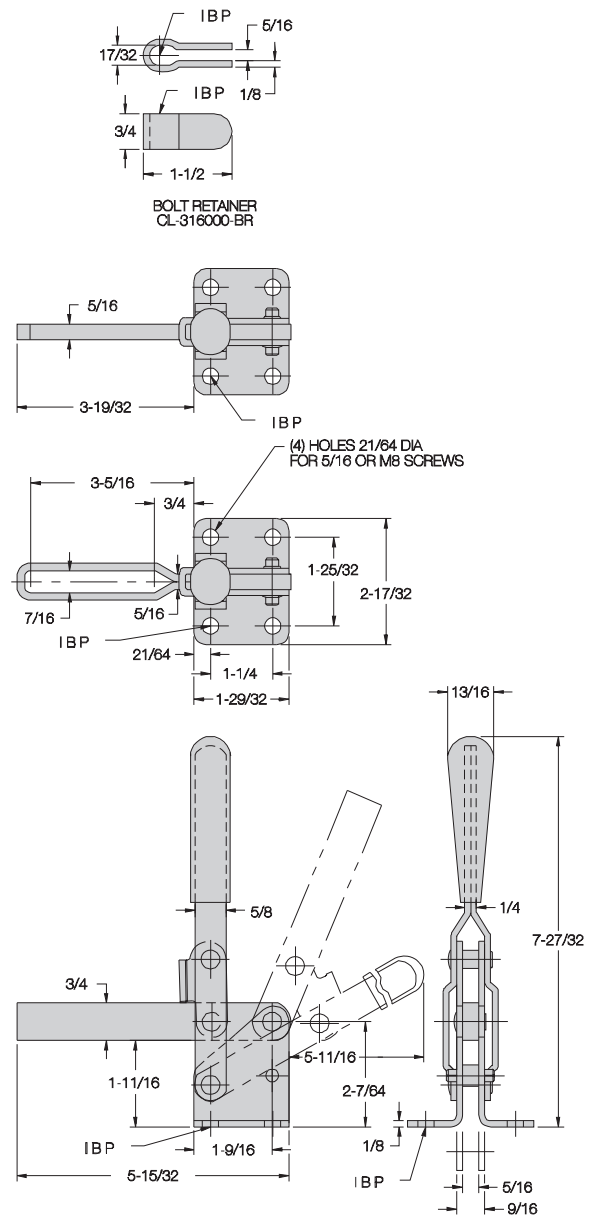

Also available with patented automatic adjustment!



CL-650-ATC

Also available in stainless steel...



CL-650-VTC-S

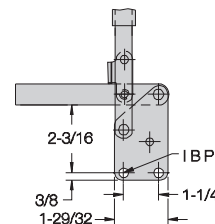

CL-651-VTC
Open Arm
Straight Base

VERTICAL-HANDLE TOGGLE CLAMPS

INFO+: SEE PAGE 439 FOR MATERIAL SPECIFICATIONS

**750 lbs
Open Arm
With Safety Lock**



CL-650-LVTC

Open Arm, Flanged Base

INFO+: Same as the wide-opening toggle clamps shown on page 472, except with our unique safety-lock feature. This safety lock automatically engages when the clamp is closed, then remains locked until manually disengaged by pressing the handle. This prevents the clamp from being accidentally opened by bumping the handle.

Open arm provides spindle adjustment. Arm opens 106° while handle moves 58°. Accepts any 3/8-16 spindle. Supplied with (2) CL-3811-TW flanged washers. Shipping weight 1.4 lbs.

Holding capacity:

750 lbs

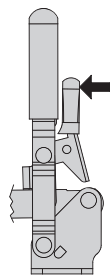
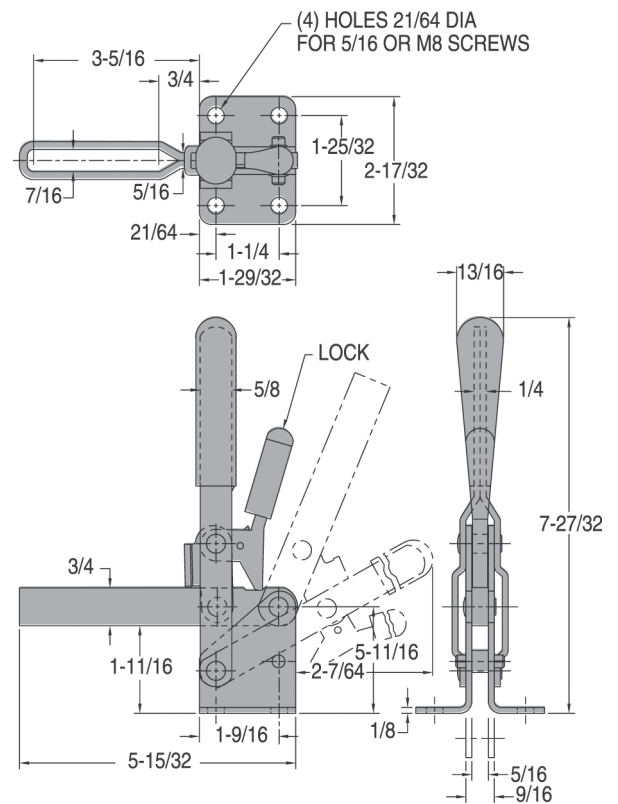

Press Lever To Unlock

VERTICAL-HANDLE TOGGLE CLAMPS

INFO+: SEE PAGE 439 FOR MATERIAL SPECIFICATIONS

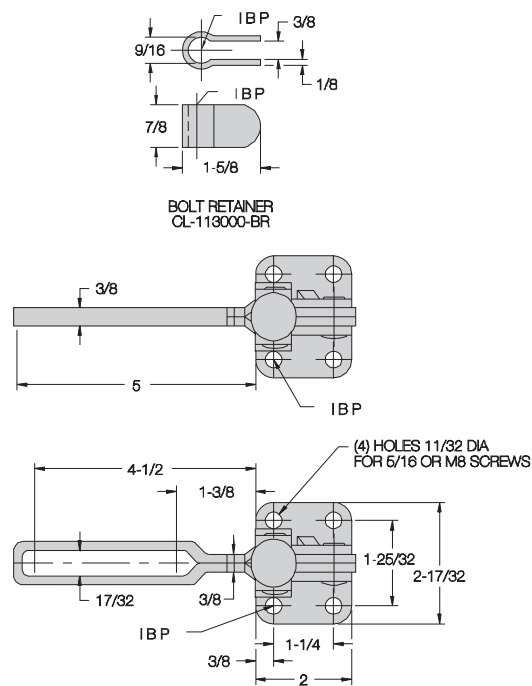
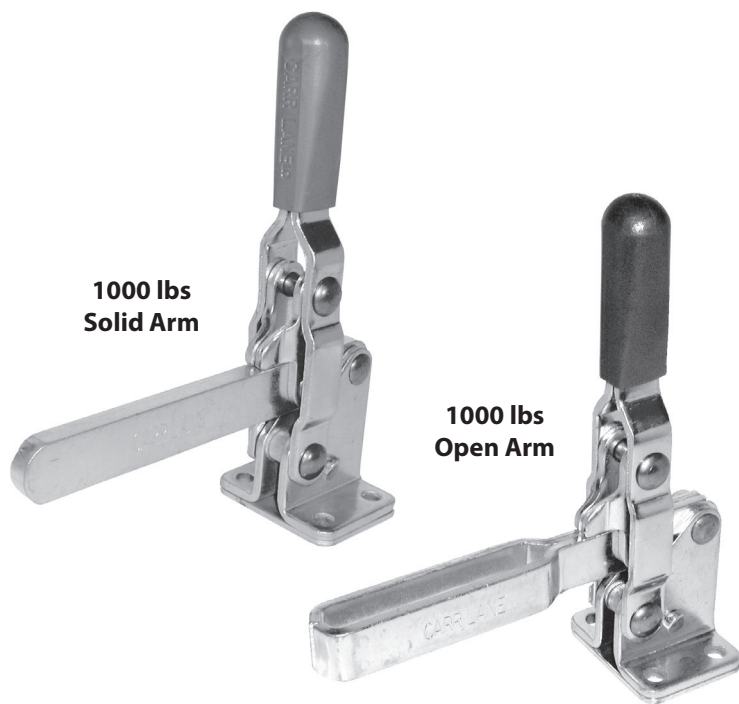

CL-750-VTC CL-850-VTC

Solid Arm, Flanged Base
Open Arm, Flanged Base

Extra-large wide-opening clamp. Choose either a solid arm, or an open arm for spindle adjustment. Arm opens 120° while handle moves 67°. Accepts any 1/2-13 spindle. Solid-arm version supplied with a CL-113000-BR bolt retainer. Open-arm version supplied with (2) CL-1213-TW flanged washers. Shipping weight 2.5 lbs.

Holding capacity: 1000 lbs

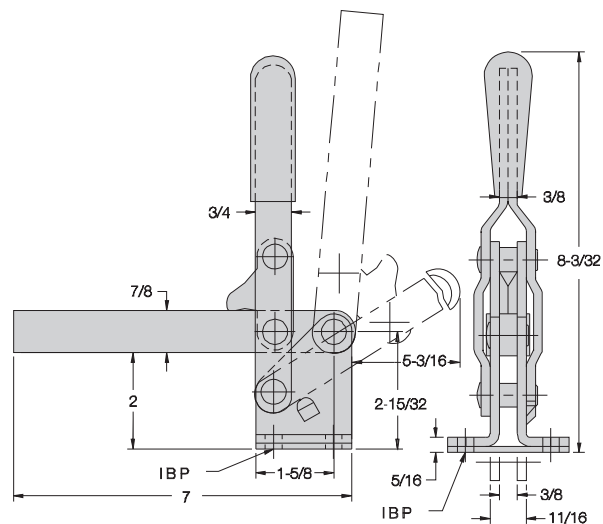

Also available air powered...



CL-2001-PTC
Solid Arm



CL-2000-PTC
Open Arm

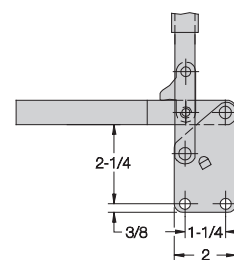

CL-851-VTC
Open Arm
Straight Base

VERTICAL-HANDLE TOGGLE CLAMPS

INFO+: SEE PAGE 439 FOR MATERIAL SPECIFICATIONS

**1000 lbs
Open Arm
With Safety Lock**



CL-850-LVTC

Open Arm, Flanged Base

INFO+: Same as the wide-opening toggle clamps shown on page 480, except with our unique safety-lock feature. This safety lock automatically engages when the clamp is closed, then remains locked until manually disengaged by pressing the handle. This prevents the clamp from being accidentally opened by bumping the handle.

Open arm provides spindle adjustment. Arm opens 120° while handle moves 67°. Accepts any 1/2-13 spindle. Supplied with (2) CL-1213-TW flanged washers. Shipping weight 2.5 lbs.

Holding capacity:

1000 lbs

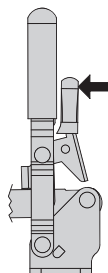
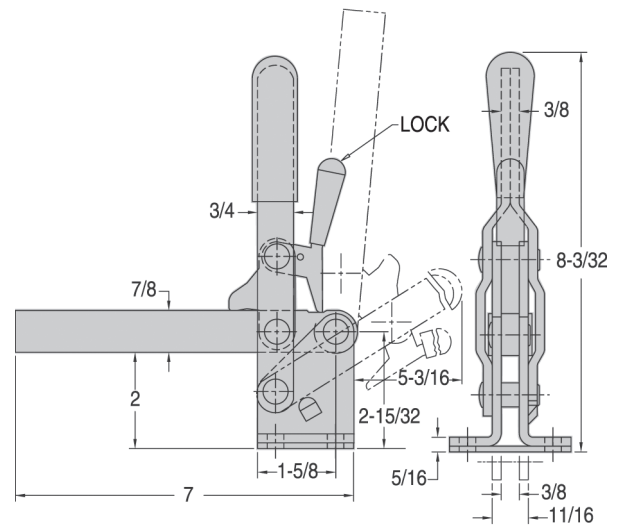
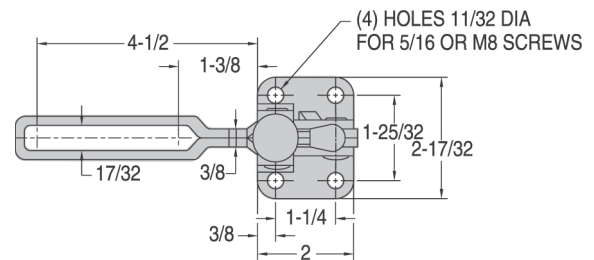

Press Lever To Unlock

11

VERTICAL-HANDLE TOGGLE CLAMPS

INFO+: SEE PAGE 439 FOR MATERIAL SPECIFICATIONS

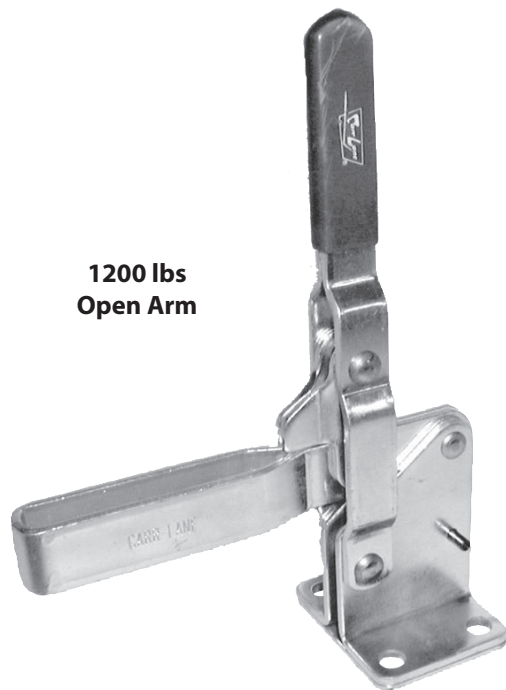

**1200 lbs
Open Arm**

CL-1050-VTC

Open Arm, Flanged Base

Largest wide-opening clamp available, with an open arm for spindle adjustment. Arm opens 140° while handle moves 70°. Accepts any 5/8-11 spindle. Supplied with (2) CL-5811-TW flanged washers. Shipping weight 5.2 lbs.

Holding capacity:

1200 lbs

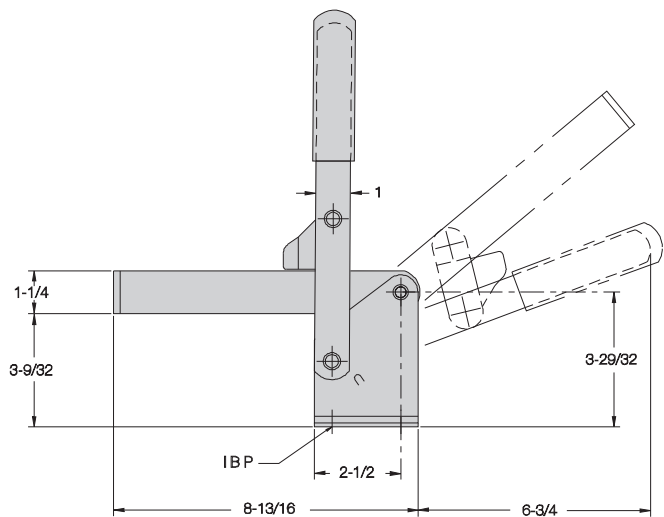
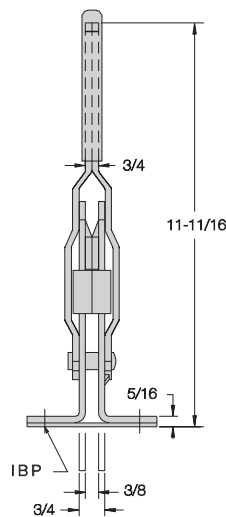
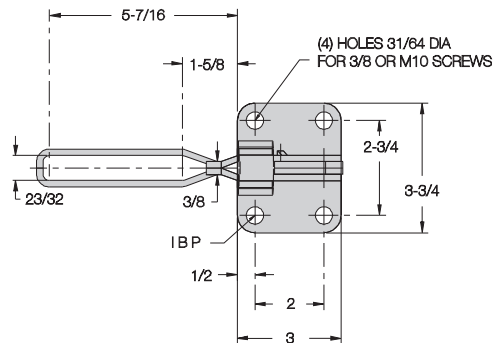

VERTICAL-HANDLE TOGGLE CLAMPS

INFO+: SEE PAGE 439 FOR MATERIAL SPECIFICATIONS



**750 lbs
Angled Arm**

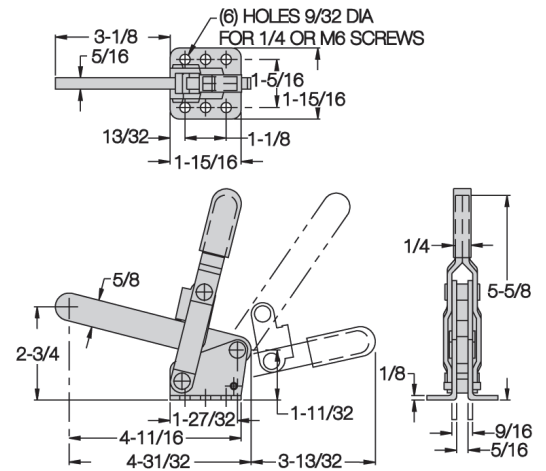

CL-600-VTC

Angled Arm, Flanged Base

Angled-arm clamp provides increased clearance underneath arm. Also useful for applying clamping force at an angle. Solid arm opens 113° while handle moves 66°. Accepts any 3/8-16 spindle. Supplied with a CL-316000-BR bolt retainer. Shipping weight 1.0 to 1.5 lbs.

Holding capacity:

750 lbs

Discover Solutions at CarrLane.com

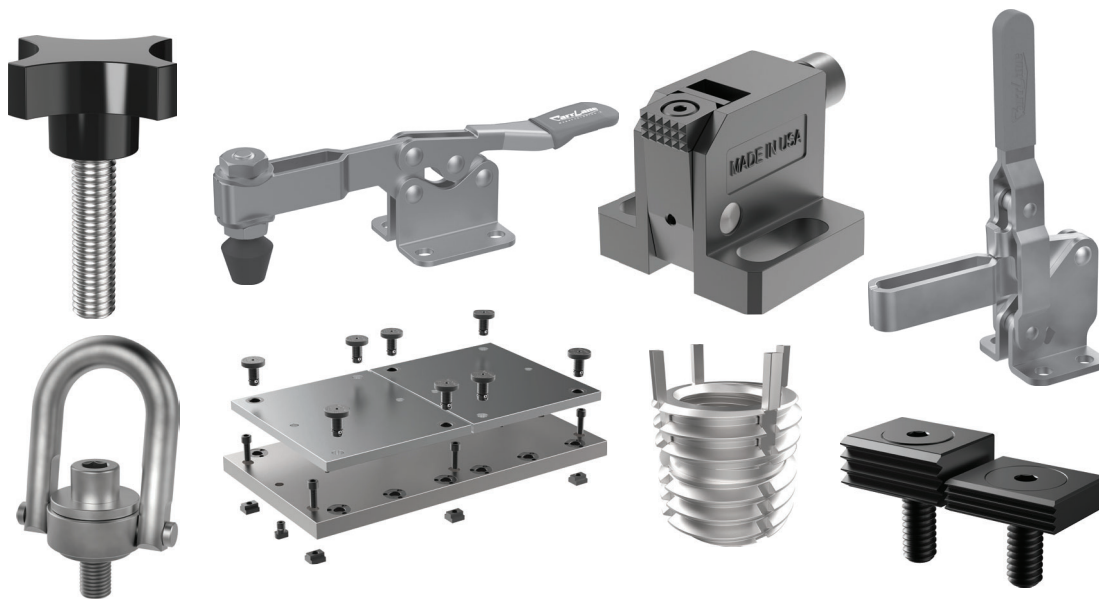

VERTICAL-HANDLE TOGGLE CLAMPS

INFO+: SEE PAGE 439 FOR MATERIAL SPECIFICATIONS



**1000 lbs
Cam Action**

CL-1000-VCC

Wide-opening clamp that locks by cam action rather than toggle action. Smooth spiral cam locks securely anywhere within a 3/16-inch clamping range. Rugged cast-steel components are flame hardened at all wear points. Solid arm can be tapped to accept a spindle, or otherwise modified. Shipping weight 2.5 lbs.

Holding capacity: 1000 lbs

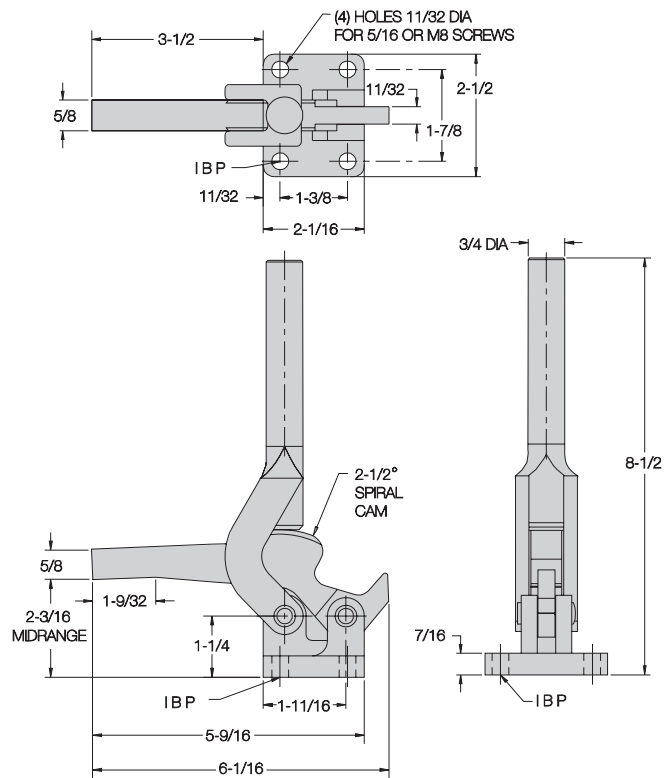

**Optional Vinyl Grip
CL-3-HVTC-G**

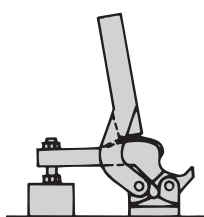

Low Limit

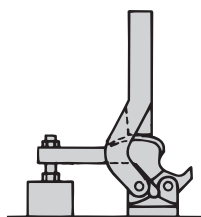

Average Setting

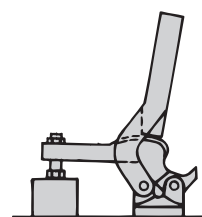

High Limit

VERTICAL-HANDLE TOGGLE CLAMPS

INFO+: SEE PAGE 439 FOR MATERIAL SPECIFICATIONS

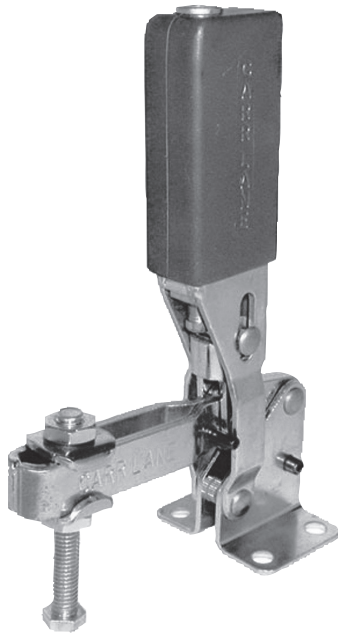

**750 lbs
Automatic Toggle Clamp
(Self Adjusting)**

CL-650-ATC

Automatically adjusts for different workpiece thicknesses! Clamps with the same force anywhere within its adjustment range (1-1/4"). Perfect for welding fixtures, machining fixtures for castings, fixtures holding several part sizes within the same family, or any other application where part size can vary.

Easy to use. To set up, simply adjust the contact spindle to the average workpiece height, and set desired clamping force. After that, operate just like a standard toggle clamp. The patented adjusting mechanism does the rest.

Clamping force is always consistent. The clamp's toggle action ensures that workpieces will remain clamped even under severe vibration. No additional spindle adjustment is ever needed. The clamp even compensates for wear in long production runs.

Fits in the same space, and provides the same clamping force as a standard toggle clamp. A maximum of 250 to 500 lbs clamping force (depending on spindle position) can be applied by hand. Arm opens 106° while handle moves 58°. Supplied with 3/8-16 radius spindle CL-38314-RS and (2) CL-3811-TW flanged washers. **Patent no. 4,407,493.** Shipping weight 1.9 lbs

Holding capacity:

750 lbs

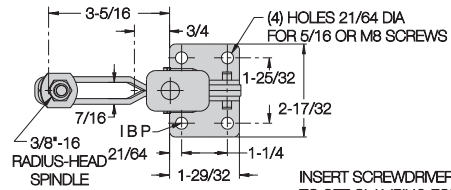

INSERT SCREWDRIVER HERE TO SET CLAMPING FORCE BY TURNING SLOTTED SCREW

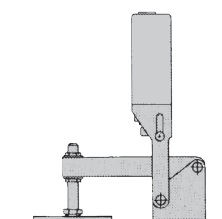
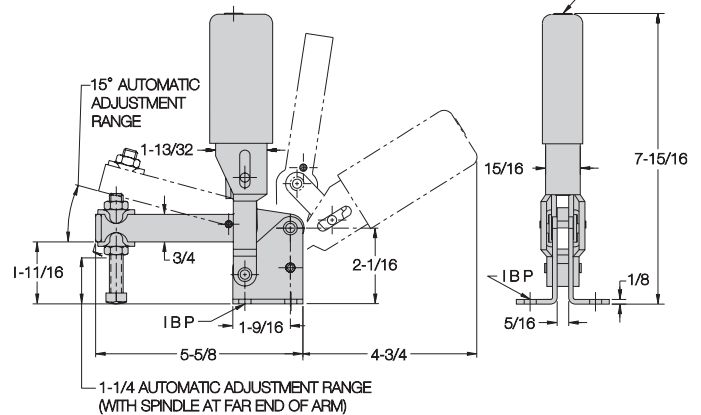

Low Limit

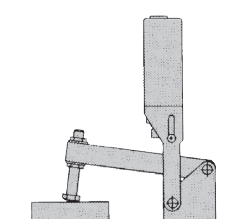

Average Setting

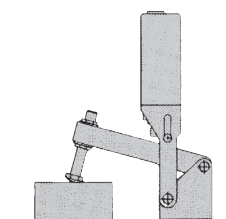

High Limit

VERTICAL-HANDLE TOGGLE CLAMPS

INFO+: SEE PAGE 439 FOR MATERIAL SPECIFICATIONS

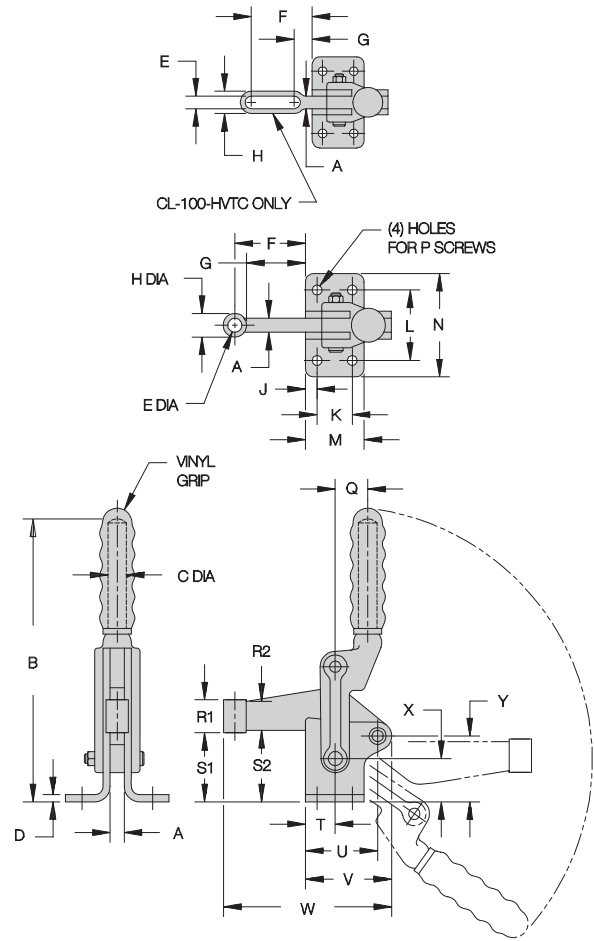
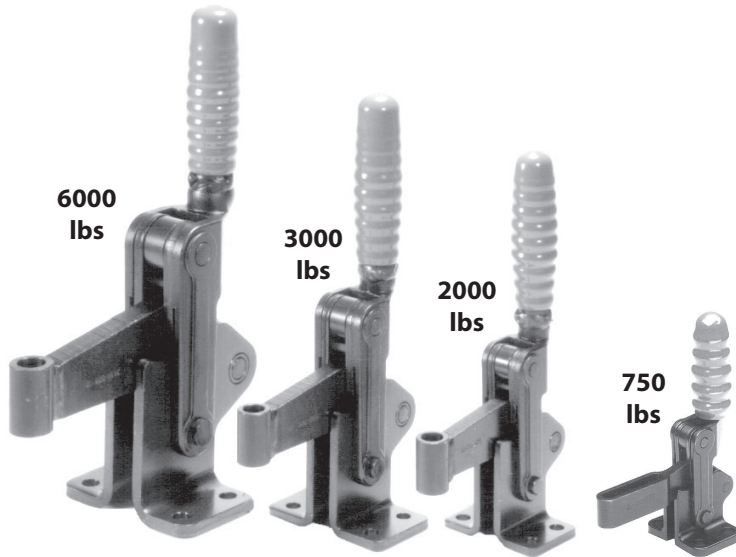

Heavy-duty automotive-type production clamps designed for extreme durability. The above configuration includes a long horizontal clamping arm with an attached bolt retainer, a vertical handle with vinyl grip, and an integral flanged base (INFO+: see pages 481-483 for other versions). Precision, close-tolerance steel components throughout provide exceptionally smooth operation. Rugged alloy steel handle fork. Guided-arm feature provides positive lateral arm support. All pivot pins are hardened and ground, running in either hardened bushings or the close-tolerance holes of hardened parts. The bottom pivot is a precision bolt which can be adjusted, if desired, to fine tune the amount of free play. These clamps are built to withstand abuse. With just occasional lubrication, they will provide extremely long service life. Black oxide finish. Available in four sizes.

CL-100-HVTC Complete Clamp, Flanged Base

Smallest of the four sizes, yet still quite powerful. Cast alloy steel base and slotted open clamping arm on this size only. Arm opens 130° while handle moves 90°. Accepts any 1/4-20 spindle. Supplied with (2) CL-148-TW flanged washers. Shipping weight 1.0 lbs.

Holding capacity: 750 lbs

CL-302-HVTC Complete Clamp, Flanged Base

Solid arm opens 180° while handle moves 120°. Accepts any 1/2-13 spindle. Shipping weight 2.8 lbs.

Holding capacity: 2000 lbs

CL-502-HVTC Complete Clamp, Flanged Base

Solid arm opens 180° while handle moves 125°. Accepts any 1/2-13 spindle. Shipping weight 4.3 lbs.

Holding capacity: 3000 lbs

CL-602-HVTC Complete Clamp, Flanged Base

Our most-powerful hold-down toggle clamp. Solid arm opens 195° while handle moves 130°. Accepts any 5/8-11 spindle. Shipping weight 9.1 lbs.

Holding capacity: 6000 lbs

11

PART NO. COMPLETE CLAMP	A	B	C DIA	D	E	F	G	H	J	K	L	M	N	P	Q	R1	R2	S1	S2	T	U	V	W	X	Y
CL-100-HVTC	.236	4.45	.50	.197	.26	1.54	.35	.49	.236	.748	1.260	1.22	1.73	1/4 or M6	.55	.59	.59	.98	.98	.59	1.26	1.54	3.31	.51	.87
CL-302-HVTC	.394	8.46	.75	.197	.52	1.97	1.57	.75	.394	.984	1.969	1.77	2.64	5/16 or M8	.91	1.18	.87	1.89	1.89	.98	2.13	2.52	4.87	1.10	1.72
CL-502-HVTC	.472	9.84	.87	.236	.52	2.36	1.97	.75	.394	1.181	2.362	1.97	3.46	5/16 or M8	.98	1.18	1.02	2.28	2.32	.98	2.40	2.92	5.66	1.42	2.19
CL-602-HVTC	.630	11.61	.98	.315	.64	2.95	2.36	1.00	.472	1.575	2.953	2.48	4.13	3/8 or M10	1.38	1.50	1.26	2.76	2.95	1.57	3.31	3.98	7.43	1.81	2.76

VERTICAL-HANDLE TOGGLE CLAMPS

INFO+: SEE PAGE 439 FOR MATERIAL SPECIFICATIONS

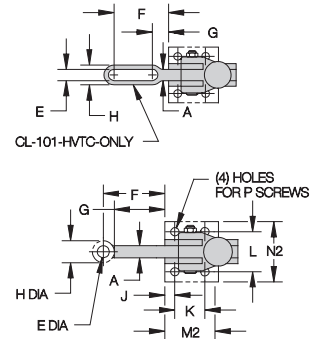
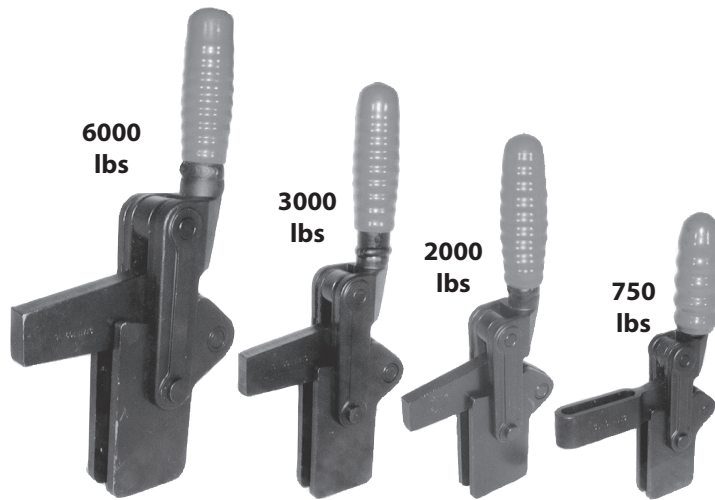

Heavy-duty automotive-type production clamps designed for extreme durability. The above configuration includes a long horizontal clamping arm furnished with a bolt retainer (not welded on), a vertical handle with vinyl grip, and a straight base for plate/tongue mounting at any angle. Precision, close-tolerance steel components throughout provide exceptionally smooth operation. Rugged alloy steel handle fork. Guided-arm feature provides positive lateral arm support. All pivot pins are hardened and ground, running in either hardened bushings or the close-tolerance holes of hardened parts. The bottom pivot is a precision bolt which can be adjusted, if desired, to fine tune the amount of free play. These clamps are built to withstand abuse. With just occasional lubrication, they will provide extremely long service life. Black oxide finish. Available in four sizes.

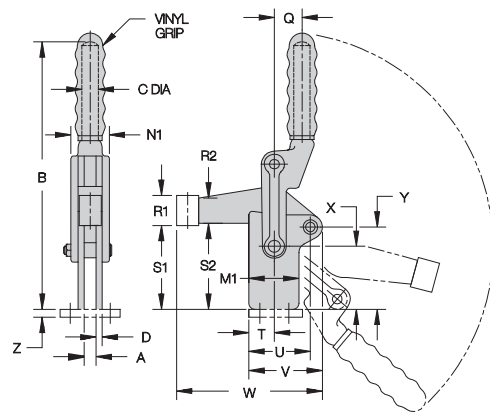

CL-101-HVTC Complete Clamp, Straight Base

Smallest of the four sizes, yet still quite powerful. Cast alloy steel slotted open clamping arm on this size only. Arm opens 205° while handle moves 130°. Accepts any 1/4-20 spindle. Supplied with (2) CL-148-TW flanged washers. Shipping weight 0.9 lbs.

Holding capacity: 750 lbs

CL-303-HVTC Complete Clamp, Straight Base

Solid arm opens 205° while handle moves 130°. Accepts any 1/2-13 spindle. Shipping weight 2.5 lbs.

Holding capacity: 2000 lbs

CL-503-HVTC Complete Clamp, Straight Base

Solid arm opens 195° while handle moves 130°. Accepts any 1/2-13 spindle. Shipping weight 4.0 lbs.

Holding capacity: 3000 lbs

CL-601-HVTC Complete Clamp, Straight Base

Our most-powerful hold-down toggle clamp. Solid arm opens 195° while handle moves 130°. Accepts any 5/8-11 spindle. Shipping weight 8.3 lbs.

Holding capacity: 6000 lbs

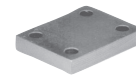
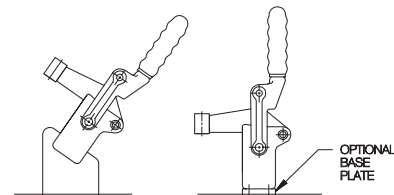

Base Plate (order separately)

CL-1-HVTC-P (750 lbs) CL-5-HVTC-P (3000 lbs)
CL-3-HVTC-P (2000 lbs) CL-6-HVTC-P (6000 lbs)

PART NO. COMPLETE CLAMP	A	B	C DIA	D	E	F	G	H	J	K	L	M1	M2	N1	N2	P	Q	R1	R2	S1	S2	T	U	V	W	X	Y	Z
CL-101-HVTC	.236	5.08	.50	.118	.26	1.54	.35	.49	.236	.748	1.260	1.06	1.10	.79	1.73	#10 or M5	.55	.59	.59	1.61	1.61	.59	1.26	1.54	3.31	1.14	1.50	.236
CL-303-HVTC	.394	9.25	.75	.197	.52	1.97	1.57	.75	.295	.984	1.378	1.77	1.57	1.26	1.97	1/4 or M6	.91	1.18	.87	2.76	2.76	.98	2.13	2.52	4.87	1.97	2.59	.315
CL-503-HVTC	.472	10.87	.87	.236	.52	2.36	1.97	.75	.394	1.181	1.575	1.97	1.97	1.50	2.36	5/16 or M8	.98	1.18	1.02	3.35	3.39	.98	2.40	2.92	5.66	2.48	3.25	.315
CL-601-HVTC	.630	12.60	.98	.315	.64	2.95	2.36	1.00	.394	1.772	1.969	2.48	2.56	1.97	2.76	5/16 or M8	1.38	1.50	1.26	3.94	4.13	1.57	3.31	3.98	7.43	2.99	3.94	.315

VERTICAL-HANDLE TOGGLE CLAMPS

INFO+: SEE PAGE 439 FOR MATERIAL SPECIFICATIONS

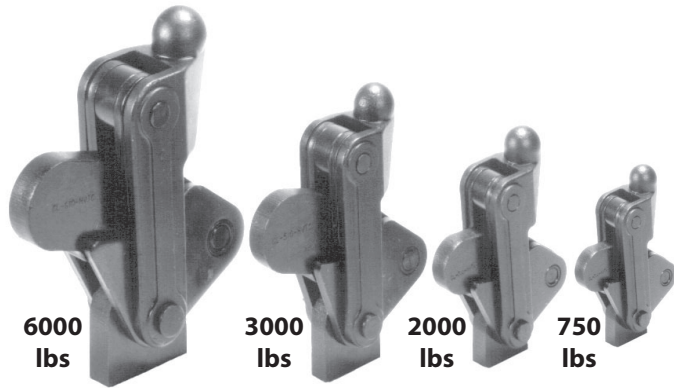

Heavy-duty automotive-type production clamps designed for extreme durability. The above configuration is a basic toggle mechanism onto which an arm and handle can be welded at any desired angle. The pivot base must be welded to both the clamp mechanism and the fixture, or the optional base plate, after setting the clamp at the proper angle. Precision, close-tolerance steel components throughout provide exceptionally smooth operation. Rugged alloy steel handle fork. Guided-arm feature provides positive lateral arm support. All pivot pins are hardened and ground, running in either hardened bushings or the close-tolerance holes of hardened parts. The bottom pivot is a precision bolt which can be adjusted, if desired, to fine tune the amount of free play. These clamps are built to withstand abuse. With just occasional lubrication, they will provide extremely long service life. Black oxide finish. Available in four sizes.

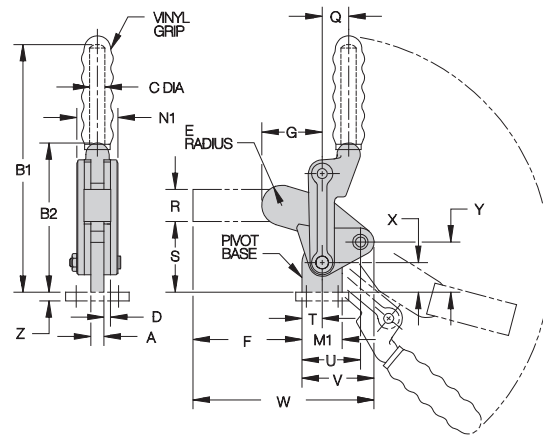
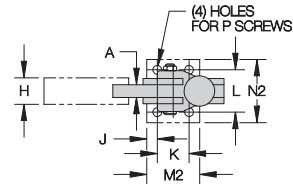

CL-110-HVTC Basic Mechanism, Pivot Base

Smallest of the four sizes, yet still quite powerful. Arm opens 205° while handle moves 130°. Shipping weight 0.6 lbs. To order basic mechanism without the pivot base, specify part no. CL-120-HVTC.

Holding capacity: 750 lbs

CL-312-HVTC Basic Mechanism, Pivot Base

Arm opens 205° while handle moves 130°. Shipping weight 1.6 lbs. To order basic mechanism without the pivot base, specify part no. CL-320-HVTC.

Holding capacity: 2000 lbs

CL-512-HVTC Basic Mechanism, Pivot Base

Arm opens 195° while handle moves 130°. Shipping weight 2.9 lbs. To order basic mechanism without the pivot base, specify part no. CL-520-HVTC.

Holding capacity: 3000 lbs

CL-610-HVTC Basic Mechanism, Pivot Base

Our most-powerful hold-down toggle clamp. Arm opens 195° while handle moves 130°. Shipping weight 6.4 lbs. To order basic mechanism without the pivot base, specify part no. CL-620-HVTC.

Holding capacity: 6000 lbs

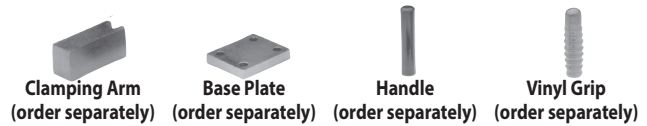
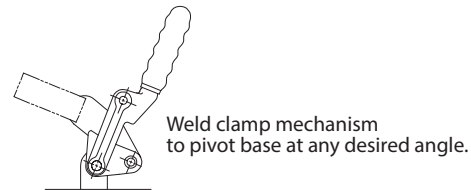

ACCESSORIES

CLAMP SIZE	PART NO. CLAMPING ARM	PART NO. BASE PLATE	PART NO. HANDLE	PART NO. VINYL GRIP
750 lbs	CL-1-HVTC-A	CL-1-HVTC-P	CL-1-HVTC-H	CL-1-HVTC-G
2000 lbs	CL-3-HVTC-A	CL-3-HVTC-P	CL-3-HVTC-H	CL-3-HVTC-G
3000 lbs	CL-5-HVTC-A	CL-5-HVTC-P	CL-5-HVTC-H	CL-5-HVTC-G
6000 lbs	CL-6-HVTC-A	CL-6-HVTC-P	CL-6-HVTC-H	CL-6-HVTC-G

PART NO. BASIC MECHANISM	A	B1	B2	C DIA	D	E	F	G	H	J	K	L	M1	M2	N1	N2	P	Q	R	S	T	U	V	W	X	Y	Z
CL-110-HVTC	.236	4.33	2.60	.50	.118	.39	2.76	1.14	.472	.197	.709	.984	.71	1.10	.79	1.38	#10 or M5	.55	.630	.94	.35	1.02	1.30	4.06	.39	.75	.236
CL-312-HVTC	.394	8.07	4.49	.75	.197	.55	2.97	1.57	.787	.295	.984	1.378	1.14	1.57	1.26	1.97	1/4 or M6	.91	.984	1.79	.57	1.71	2.11	5.08	.79	1.41	.315
CL-512-HVTC	.472	9.49	5.47	.87	.236	.75	4.06	2.24	.984	.394	1.181	1.575	1.50	1.97	1.54	2.36	5/16 or M8	.98	1.181	2.64	.75	2.17	2.68	6.74	1.10	1.87	.315
CL-610-HVTC	.630	10.91	6.97	.98	.315	.87	5.16	2.83	1.181	.394	1.772	1.969	2.05	2.56	1.97	2.76	5/16 or M8	1.38	1.378	3.33	1.02	2.74	3.43	8.59	1.30	2.24	.315

VERTICAL-HANDLE TOGGLE CLAMPS

INFO+: SEE PAGE 439 FOR MATERIAL SPECIFICATIONS

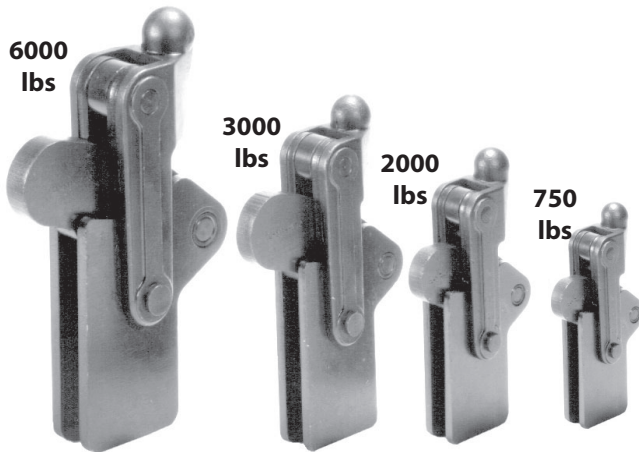

Heavy-duty automotive-type production clamps designed for extreme durability. The above configuration is a basic toggle mechanism onto which an arm and handle can be welded at any desired angle. The straight base is ideal for plate/tongue mounting at any angle. Alternatively, the optional base plate can be attached to construct a tall flanged-base clamp. Precision, close-tolerance steel components throughout provide exceptionally smooth operation. Rugged alloy steel handle fork. Guided-arm feature provides positive lateral arm support. All pivot pins are hardened and ground, running in either hardened bushings or the close-tolerance holes of hardened parts. The bottom pivot is a precision bolt which can be adjusted, if desired, to fine tune the amount of free play. These clamps are built to withstand abuse. With just occasional lubrication, they will provide extremely long service life. Black oxide finish. Available in four sizes.

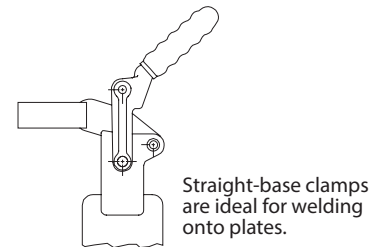
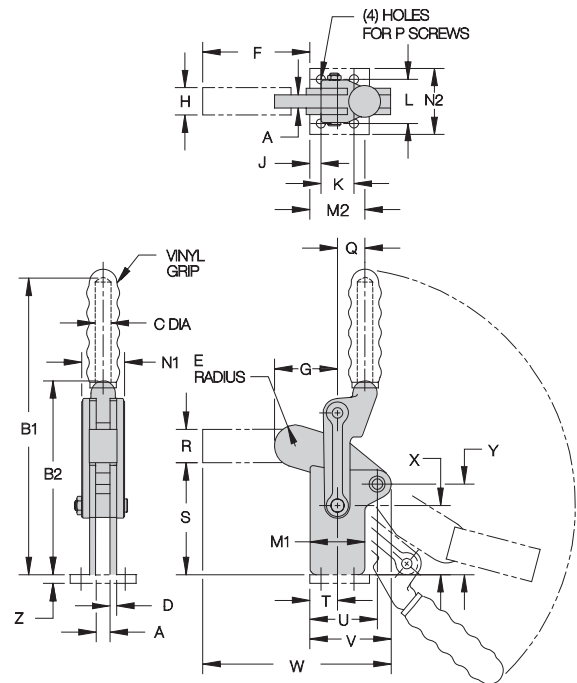

Straight-base clamps are ideal for welding onto plates.

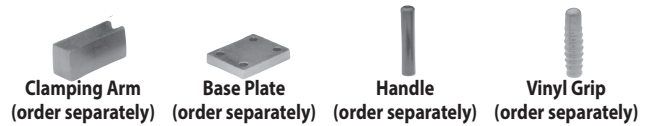

Clamping Arm (order separately) Base Plate (order separately) Handle (order separately) Vinyl Grip (order separately)

CL-111-HVTC Basic Mechanism, Straight Base

Smallest of the four sizes, yet still quite powerful. Arm opens 205° while handle moves 130°. Shipping weight 0.8 lbs.

Holding capacity: 750 lbs

CL-311-HVTC Basic Mechanism, Straight Base

Arm opens 205° while handle moves 130°. Shipping weight 1.8 lbs.

Holding capacity: 2000 lbs

CL-513-HVTC Basic Mechanism, Straight Base

Arm opens 195° while handle moves 130°. Shipping weight 3.2 lbs.

Holding capacity: 3000 lbs

CL-611-HVTC Basic Mechanism, Straight Base

Our most-powerful hold-down toggle clamp. Arm opens 195° while handle moves 130°. Shipping weight 7.1 lbs.

Holding capacity: 6000 lbs

ACCESSORIES

CLAMP SIZE	PART NO. CLAMPING ARM	PART NO. BASE PLATE	PART NO. HANDLE	PART NO. VINYL GRIP
750 lbs	CL-1-HVTC-A	CL-1-HVTC-P	CL-1-HVTC-H	CL-1-HVTC-G
2000 lbs	CL-3-HVTC-A	CL-3-HVTC-P	CL-3-HVTC-H	CL-3-HVTC-G
3000 lbs	CL-5-HVTC-A	CL-5-HVTC-P	CL-5-HVTC-H	CL-5-HVTC-G
6000 lbs	CL-6-HVTC-A	CL-6-HVTC-P	CL-6-HVTC-H	CL-6-HVTC-G

PART NO. BASIC MECHANISM	A	B1	B2	C DIA	D	E	F	G	H	J	K	L	M1	M2	N1	N2	P	Q	R	S	T	U	V	W	X	Y	Z
CL-111-HVTC	.236	5.08	3.39	.50	.118	.39	2.52	1.14	.472	.197	.709	.984	1.06	1.10	.79	1.38	#10 or M5	.55	.630	1.73	.59	1.26	1.54	4.06	1.18	1.54	.236
CL-311-HVTC	.394	9.25	5.67	.75	.197	.55	2.56	1.57	.787	.295	.984	1.378	1.77	1.57	1.26	1.97	1/4 or M6	.91	.984	2.97	.98	2.13	2.52	5.08	1.97	2.59	.315
CL-513-HVTC	.472	10.87	6.97	.87	.236	.75	3.82	2.24	.984	.394	1.181	1.575	1.97	1.97	1.50	2.36	5/16 or M8	.98	1.181	4.02	.98	2.40	2.92	6.74	2.48	3.25	.315
CL-611-HVTC	.630	12.60	8.66	.98	.315	.87	4.61	2.83	1.181	.394	1.772	1.969	2.48	2.56	1.97	2.76	5/16 or M8	1.38	1.378	5.02	1.57	3.31	3.98	8.59	2.99	3.94	.315

VERTICAL-HANDLE TOGGLE CLAMPS

INFO+: SEE PAGE 439 FOR MATERIAL SPECIFICATIONS

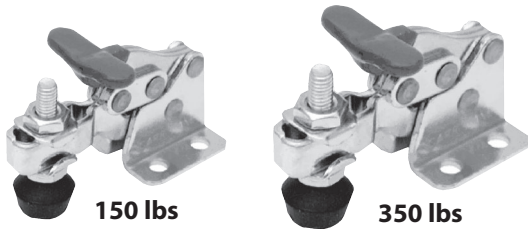

Hold-down toggle clamp with a unique finger-grip T handle. Extremely compact design. Open arm provides adjustable spindle location. Arm opens 92° while handle moves 175°.

CL-200-VTC

Miniature-size T-handle clamp. Supplied with #10-32 flat-cushion spindle CL-316112-FC and (2) CL-3166-TW flanged washers. Shipping weight 0.2 lbs.

Holding capacity: 150 lbs

CL-300-VTC

Medium-size T-handle clamp. Supplied with 5/16-18 flat-cushion spindle CL-518208-FC and (2) CL-51610-TW flanged washers. Shipping weight 0.6 lbs.

Holding capacity: 350 lbs

CL-500-VTC

Large-size T-handle clamp. Supplied with 3/8-16 flat-cushion spindle CL-38212-FC and (2) CL-3811-TW flanged washers. Shipping weight 1.3 lbs.

Holding capacity: 750 lbs

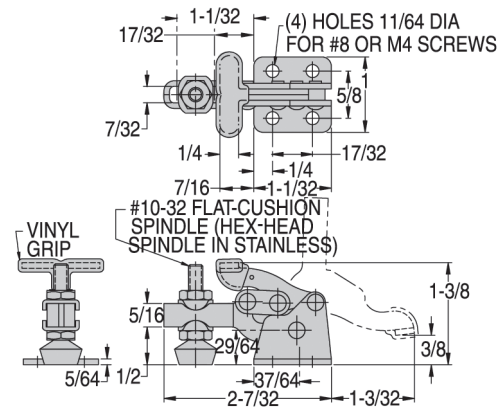

CL-200-VTC

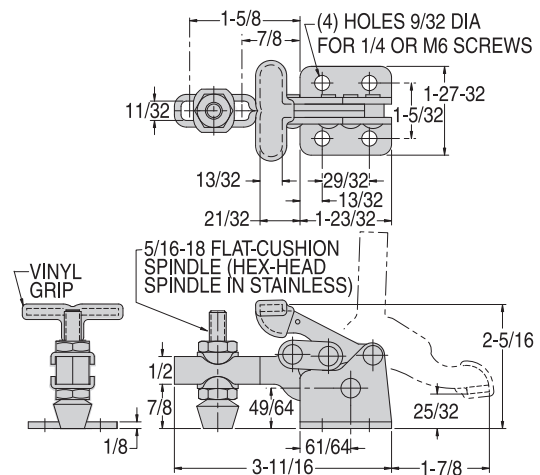

CL-300-VTC

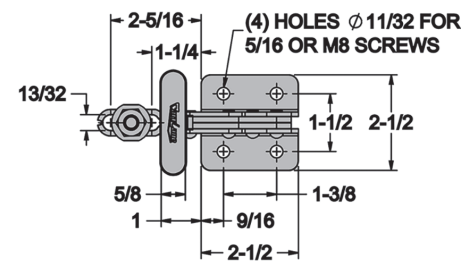

3/8-11 FLAT-CUSHION SPINDLE (HEX-HEAD SPINDLE IN STAINLESS)

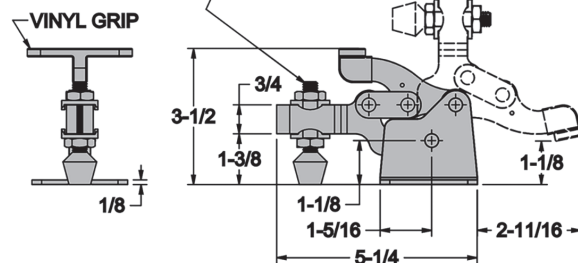

CL-500-VTC

Also available in stainless steel...



VERTICAL-HANDLE TOGGLE CLAMPS

INFO+: SEE PAGE 439 FOR MATERIAL SPECIFICATIONS

**750 lbs
With Safety Lock**

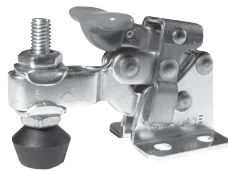
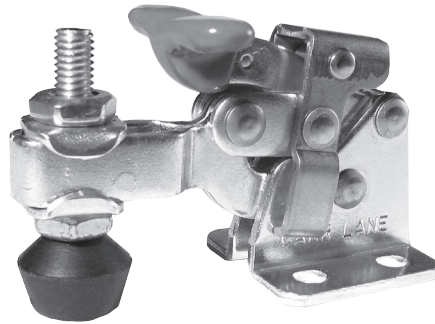

**150 lbs
With Safety Lock**

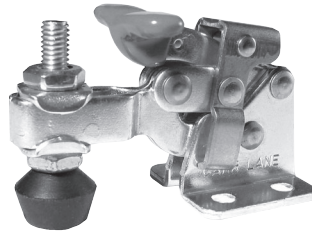

**350 lbs
With Safety Lock**

INFO+: Same as our hold-down toggle clamps on page 470, except with our unique safety-lock feature. This safety lock automatically engages when the clamp is closed, then remains locked until manually disengaged by pressing the lever before opening. This prevents the clamp from being accidentally opened by bumping the handle. This clamp has a unique finger-grip T handle. Extremely compact design. Open arm provides adjustable spindle location. Arm opens 92° while handle moves 175°.

CL-200-LVTC

Miniature-size T-handle clamp. Supplied with #10-32 flat-cushion spindle CL-316112-FC and (2) CL-3166-TW flanged washers. Shipping weight 0.2 lbs.

Holding capacity: 150 lbs

CL-300-LVTC

Medium-size T-handle clamp. Supplied with 5/16-18 flat-cushion spindle CL-518208-FC and (2) CL-51610-TW flanged washers. Shipping weight 0.6 lbs.

Holding capacity: 350 lbs

CL-500-LVTC

Large-size T-handle clamp. Supplied with 3/8-11 flat-cushion spindle CL-38212-FC and (2) CL-3811-TW flanged washers. Shipping weight 1.3 lbs.

Holding capacity: 750 lbs

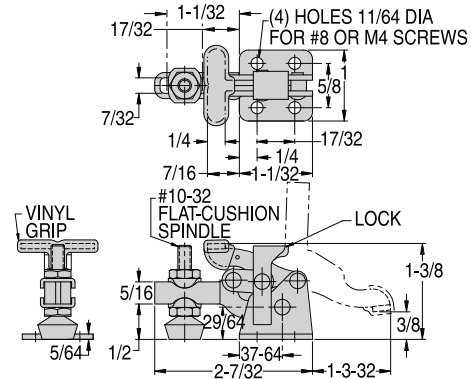

CL-200-LVTC

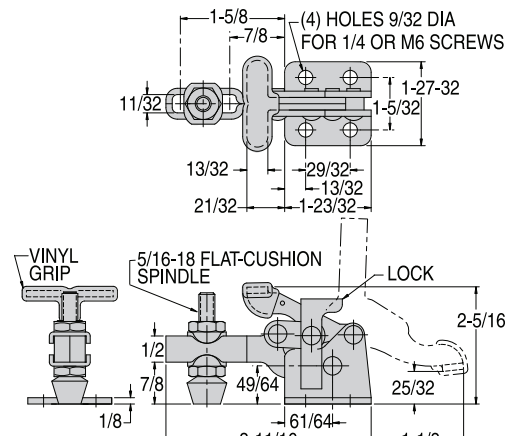

CL-300-LVTC

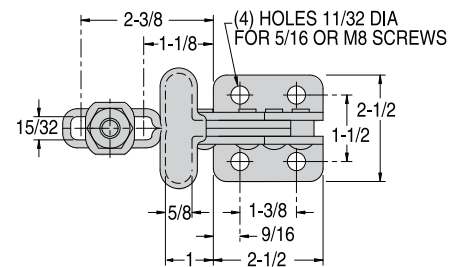

CL-500-LVTC

VERTICAL-HANDLE TOGGLE CLAMPS

INFO+: SEE PAGE 439 FOR MATERIAL SPECIFICATIONS

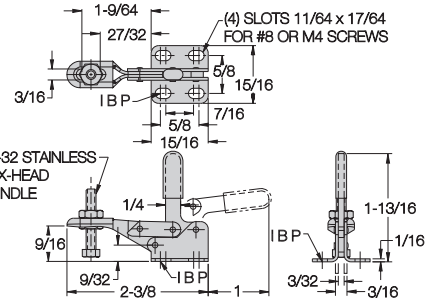
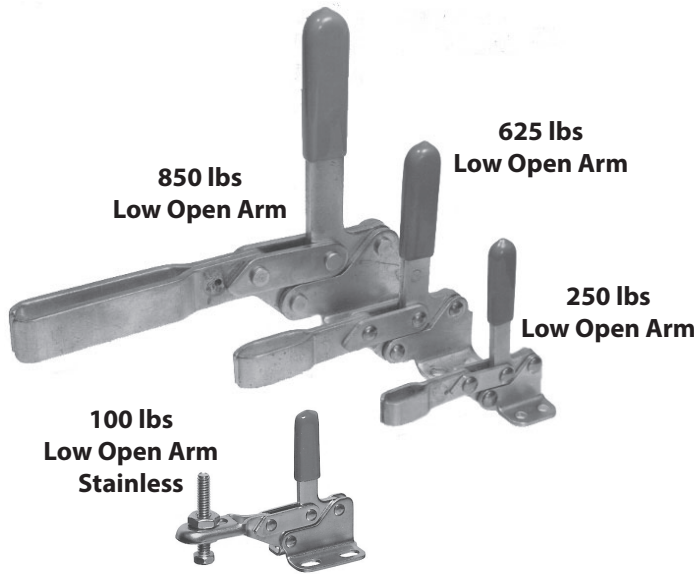

CL-11-TC

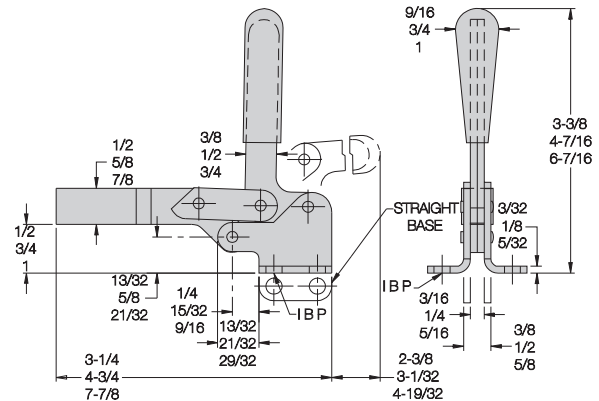
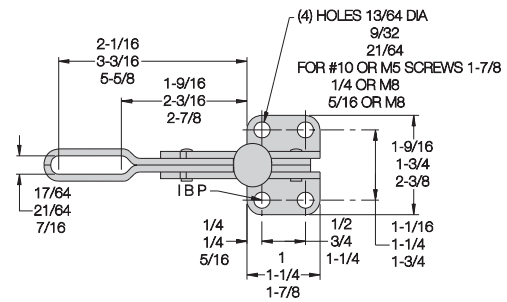

CL-111-TC (Top dimension)
CL-211-TC (Middle dimension)
CL-311-TC (Bottom dimension)

Simple, easy-opening clamps with excellent arm reach, extending farther over workpiece than any other clamps their size. Open arm allows spindle adjustment. Arm opens 83° while handle moves 83°. Available in four sizes.

CL-11-TC Low Open Arm, Flanged Base

Miniature clamp in stainless steel. Supplied with #8-32 hex-head spindle CL-832203-SA-S. Shipping weight 0.1 lbs.

Holding capacity: 100 lbs

CL-111-TC Low Open Arm, Flanged Base

Small-size clamp. Accepts any 1/4-20 spindle and (2) CL-147-TW flanged washers. Shipping weight 0.3 lbs.

Holding capacity: 250 lbs

CL-211-TC Low Open Arm, Flanged Base

Medium-size clamp. Accepts any 5/16-18 spindle and (2) CL-51610-TW flanged washers. Shipping weight 0.5 lbs.

Holding capacity: 625 lbs

CL-311-TC Low Open Arm, Flanged Base

Large-size clamp. Arm extends a full 6 inches over workpiece. Accepts any 3/8-16 spindle and (2) CL-3811-TW flanged washers. Shipping weight 1.4 lbs.

Holding capacity: 850 lbs

VERTICAL-HANDLE TOGGLE CLAMPS

INFO+: SEE PAGE 439 FOR MATERIAL SPECIFICATIONS

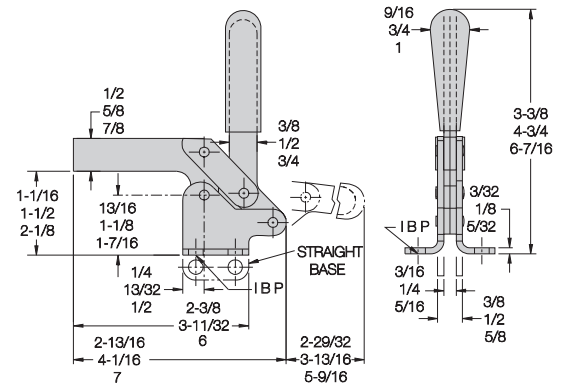
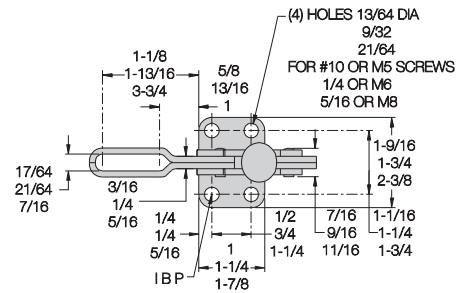
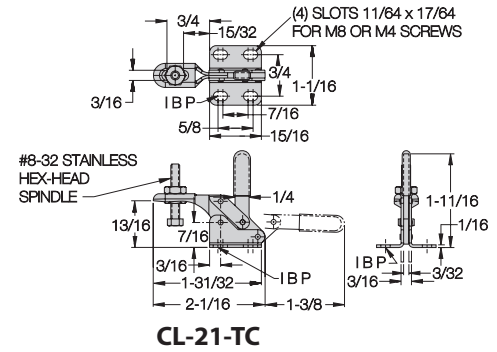
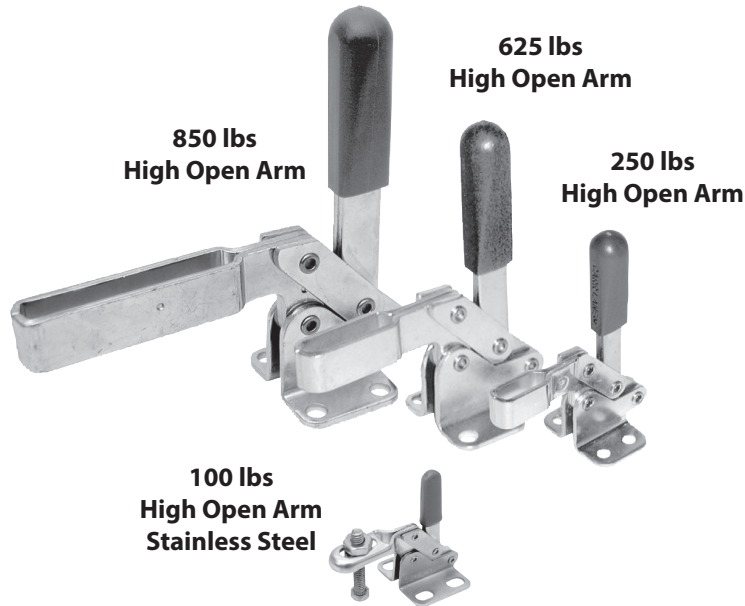

Simple, easy-opening clamps with extra arm height. Open arm allows spindle adjustment. Arm opens 83° while handle moves 83°. Available in four sizes.

CL-21-TC High Open Arm, Flanged Base

Miniature clamp in stainless steel. Supplied with #8-32 hex-head spindle CL-832203-SA-S. Shipping weight 0.1 lbs.

Holding capacity: 100 lbs

CL-101-TC High Open Arm, Flanged Base

Small-size clamp. Accepts any 1/4-20 spindle and (2) CL-147-TW flanged washers. Shipping weight 0.3 lbs.

Holding capacity: 250 lbs

CL-201-TC High Open Arm, Flanged Base

Medium-size clamp. Accepts any 5/16-18 spindle and (2) CL-51610-TW flanged washers. Shipping weight 0.5 lbs.

Holding capacity: 625 lbs

CL-301-TC High Open Arm, Flanged Base

Large-size clamp. Accepts any 3/8-16 spindle and (2) CL-3811-TW flanged washers. Shipping weight 1.4 lbs.

Holding capacity: 850 lbs

CL-101-TC (Top dimension)
CL-201-TC (Middle dimension)
CL-301-TC (Bottom dimension)

VERTICAL-HANDLE TOGGLE CLAMPS

INFO+: SEE PAGE 439 FOR MATERIAL SPECIFICATIONS

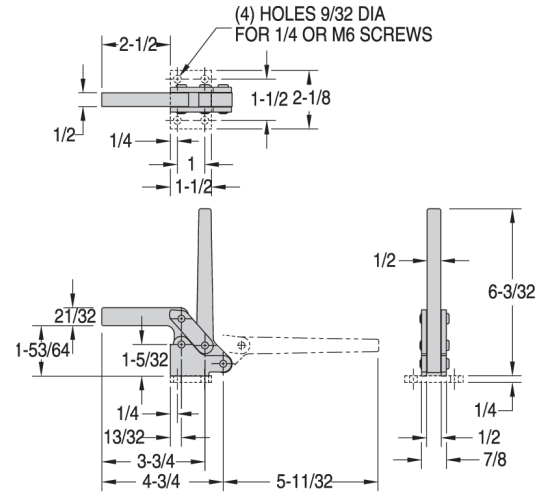

CL-45-HDC-121

Compact heavy-duty clamps with forged steel handles and clamping arms, available in three sizes. Low clamping arm extends far over workpiece. Simple, easy-opening linkage. Arm opens 83° while handle moves 83°. Weld-on flanged base is optional. To order clamp with flanged base attached, add "S" to part no. (example: CL-45-HDC-121S).

CL-45-HDC-121

Low Arm

Smallest of the three sizes, yet still quite powerful. Shipping weight 2.0 lbs.

Holding capacity:

1500 lbs

CL-50-HDC-121

Low Arm

Medium-size clamp with high strength. Shipping weight 2.5 lbs.

Holding capacity:

2500 lbs

CL-51-HDC-121

Low Arm

Largest of the three sizes. Shipping weight 5.0 lbs.

Holding capacity:

5000 lbs

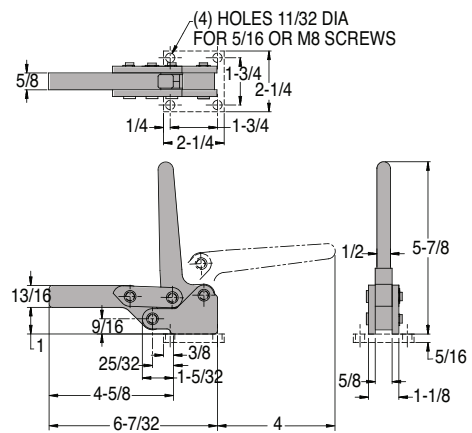

CL-50-HDC-121

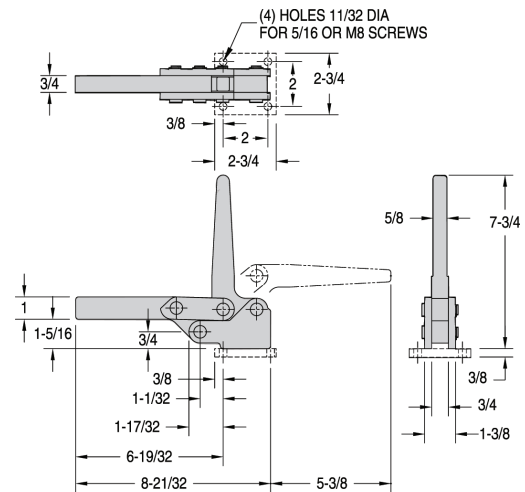

CL-51-HDC-121

Available with standard flanged base attached...



Add "S" to part no.

VERTICAL-HANDLE TOGGLE CLAMPS

INFO+: SEE PAGE 439 FOR MATERIAL SPECIFICATIONS



Compact heavy-duty clamps with forged steel handles and clamping arms, available in three sizes. High clamping arm provides extra room for thick workpieces. Simple, easy-opening linkage. Arm opens 83° while handle moves 83°. Weld-on flanged base is optional. To order clamp with flanged base attached, add "S" to part no. (example: CL-40-HDC-211S).

CL-40-HDC-211

High Arm

Smallest of the three sizes, yet still quite powerful. Shipping weight 2.0 lbs.

Holding capacity:

1500 lbs

CL-60-HDC-211

High Arm

Medium-size clamp with high strength. Shipping weight 2.5 lbs.

Holding capacity:

2500 lbs

CL-61-HDC-211

High Arm

Largest of the three sizes. Shipping weight 5.0 lbs.

Holding capacity:

5000 lbs

Available with standard flanged base attached...



Add "S" to part no.

Also available air powered...

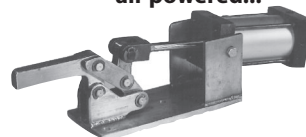

CL-3000-PTC

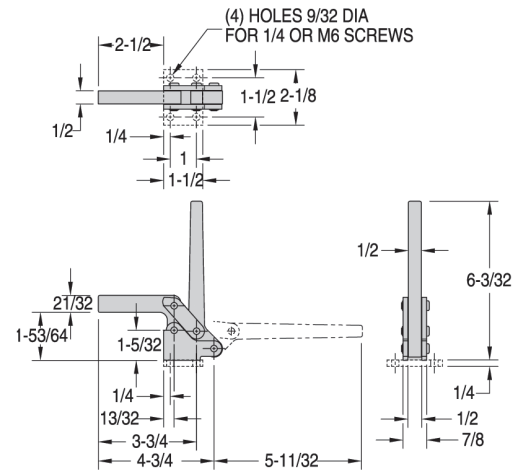

CL-40-HDC-211

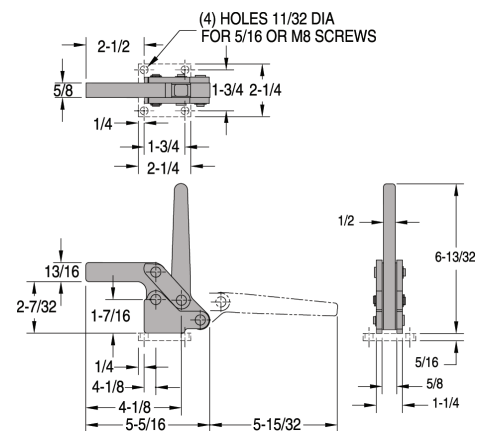

CL-60-HDC-211

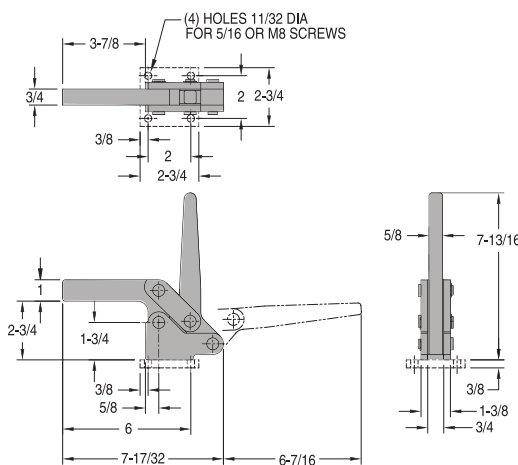

CL-61-HDC-211

PUSH / PULL TOGGLE CLAMPS

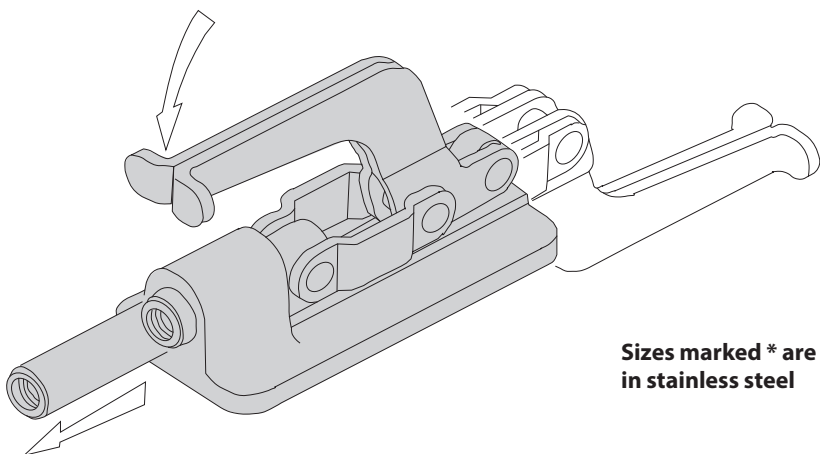

Sizes marked * are also available in stainless steel

All Carr Lane Manufacturing toggle clamps are DFARS and RoHS compliant.

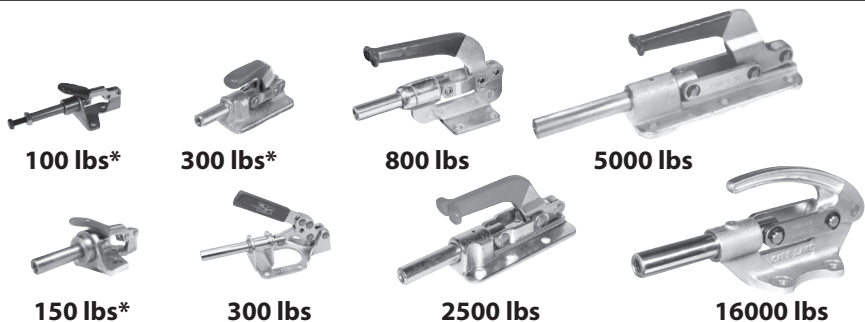

Standard SPC Design p. 477-482

Most popular series of push/pull clamps. Plunger advances and locks by moving the handle forward toward it. Clamp can also be used for pulling instead of pushing (handle locks back in downward position also). Choice of eight sizes.



Horizontal Handle p. 483

Reverse-action push clamp. Plunger advances and locks by moving the handle backward into horizontal position.



PC Design p. 484-485

Durable push/pull clamps with nodular iron bases. Plunger advances and locks by moving the handle forward toward it. Clamp can also be used for pulling instead of pushing (handle locks back in downward position also). Choice of three sizes.



Threaded Body p. 486-487

Compact push/pull clamps for mounting through panels, plates, or angle brackets. Install in a drilled or tapped hole. Plunger locks in either extended or retracted position. Rotate clamp to position handle anywhere within 360°. Choice of three sizes.

PUSH/PULL TOGGLE CLAMPS

INFO+: SEE PAGE 439 FOR MATERIAL SPECIFICATIONS

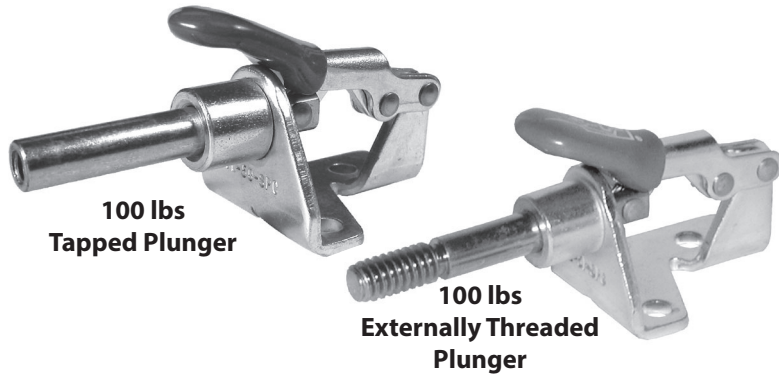

CL-50-SPC (Metric No. CLM-50-SPC)

Miniature plunger clamp, perfect for electronics fixturing and other light-duty applications. Locks in extended or retracted position. 5/8" plunger travel. Tapped-plunger version supplied with #8-32 nylon hex-head spindle CL-832203-SA (M4 in metric). Also available with 1/4-20 externally threaded plunger. Shipping weight 0.2 lbs.

Holding capacity:

100 lbs

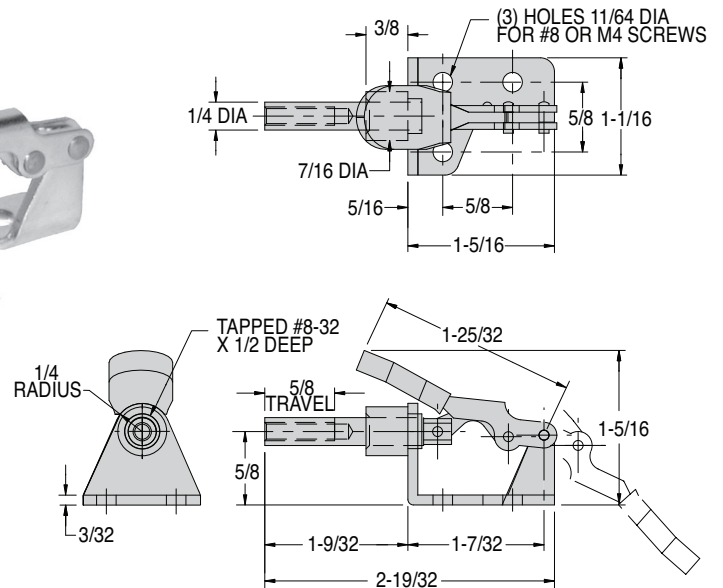
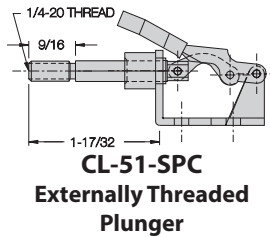

Also available in stainless steel...



PUSH/PULL TOGGLE CLAMPS

INFO+: SEE PAGE 439 FOR MATERIAL SPECIFICATIONS

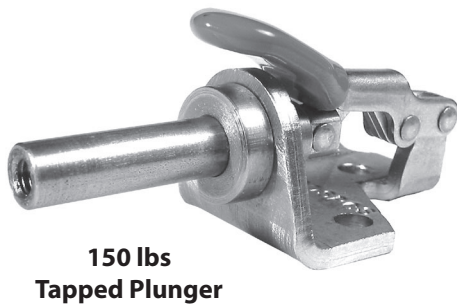

CL-60-SPC (Metric No. CLM-60-SPC)

Heavier-duty version of our smallest plunger clamp above. This is a powerful clamp in an extremely compact size. Unique base allows bottom or side mounting. Locks in extended or retracted position. 5/8" plunger travel. Plunger is tapped to accept any #8-32 spindle (M4 in metric). Shipping weight 0.2 lbs.

Holding capacity:

150 lbs

Also available in stainless steel...

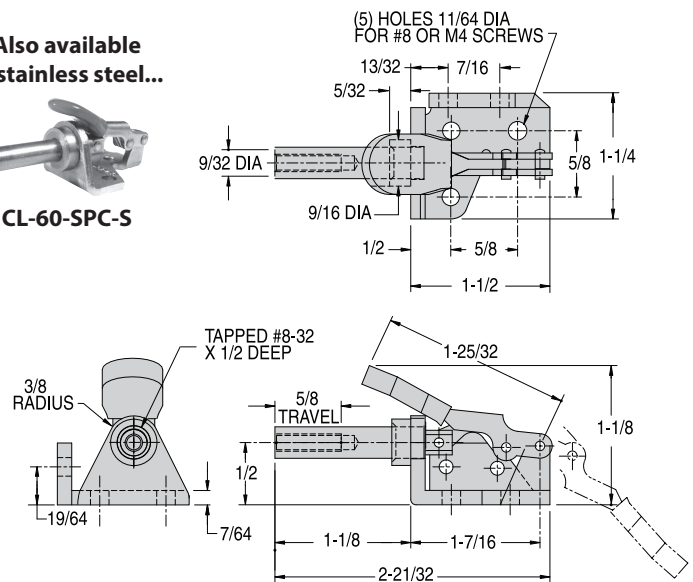
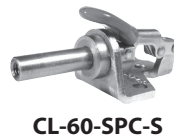

PUSH/PULL TOGGLE CLAMPS

INFO+: SEE PAGE 439 FOR MATERIAL SPECIFICATIONS

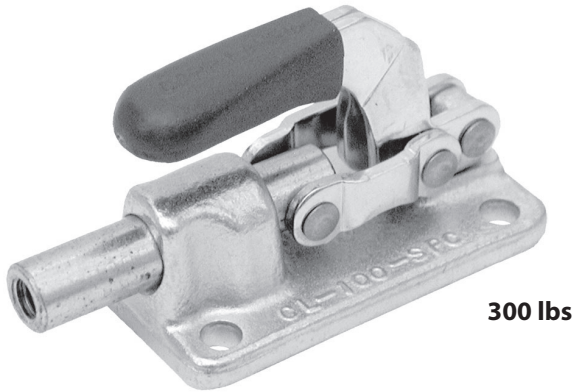

300 lbs

CL-100-SPC (Metric No. CLM-100-SPC)

Tiny, yet extremely powerful plunger clamp with a forged steel base. Requires very little mounting space due to its narrow base and compact low profile. Locks in extended or retracted position. 5/8" plunger travel. Plunger is tapped to accept any 1/4-20 spindle (M6 in metric). Shipping weight 0.5 lbs.

Holding capacity:

300 lbs

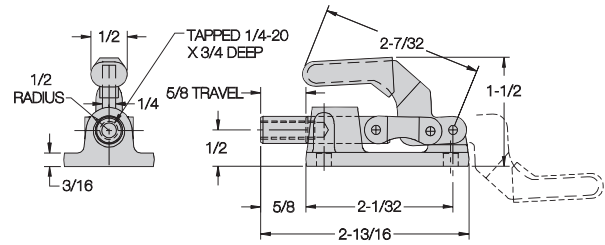
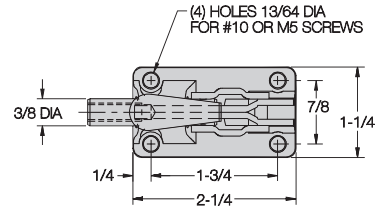

Also available
in stainless steel...



CL-100-SPC-S

PUSH/PULL TOGGLE CLAMPS

INFO+: SEE PAGE 439 FOR MATERIAL SPECIFICATIONS

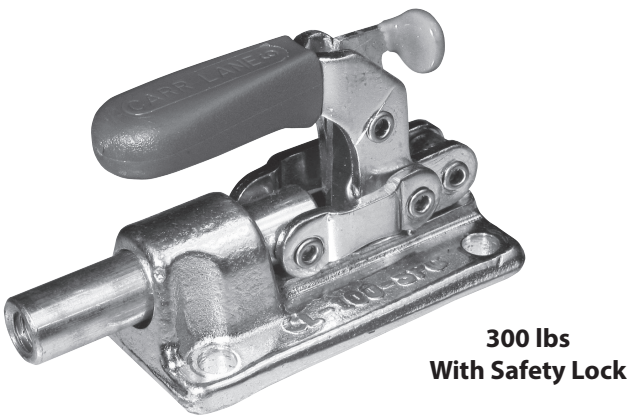

300 lbs
With Safety Lock

CL-100-LSPC (Metric No. CLM-100-LSPC)

Same as the toggle clamp shown above, except with our unique safety-lock feature. This safety lock automatically engages when the clamp is closed, then remains locked until manually disengaged by pressing the lever before opening. This prevents the clamp from being accidentally opened by bumping the handle. Shipping weight 0.6 lbs.

Holding capacity:

300 lbs

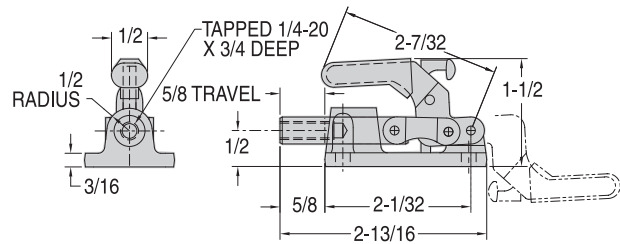
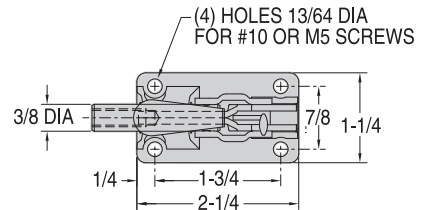

Also available
in stainless steel...

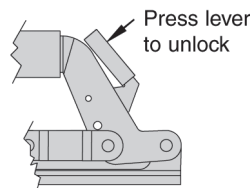

CL-100-LSPC-S

PUSH/PULL TOGGLE CLAMPS

INFO+: SEE PAGE 439 FOR MATERIAL SPECIFICATIONS



300 lbs

CL-150-SPC (Metric No. CLM-150-SPC)

Medium-size plunger clamp that locks in extended or retracted position. 1-1/4" plunger travel. Plunger is tapped to accept any 5/16-18 spindle (M8 in metric). Shipping weight 0.7 lbs.

Holding capacity:

300 lbs

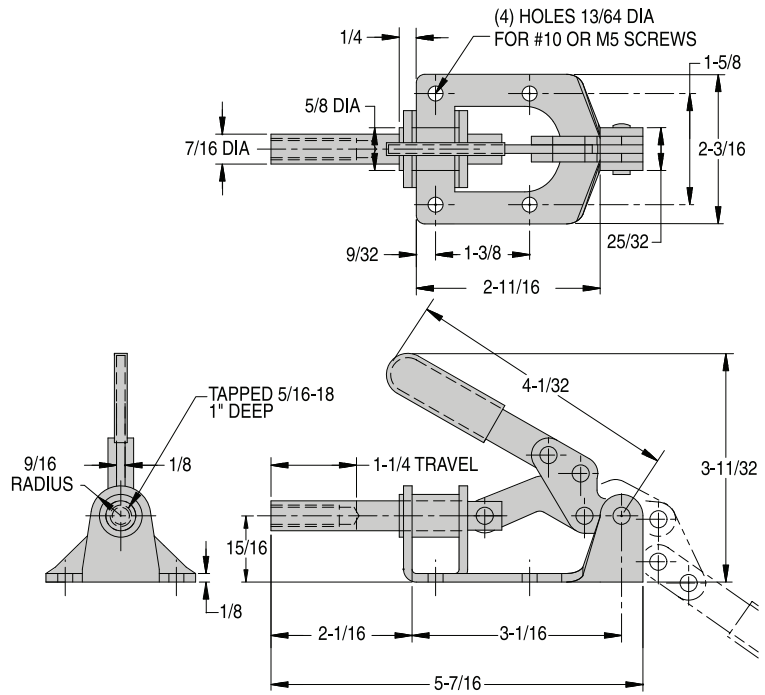

Go Lean With

CarrLock[®]
System

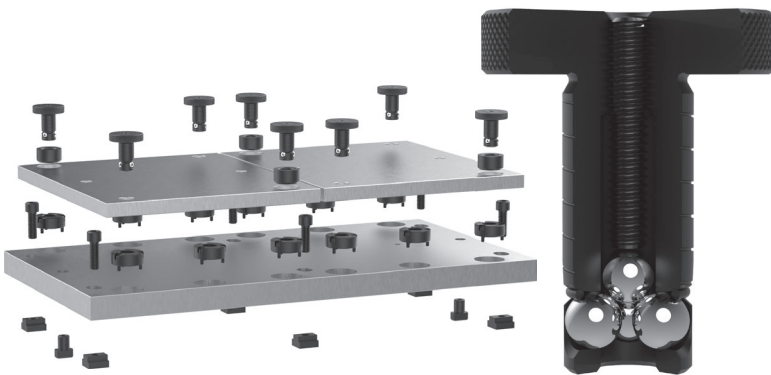

Change from job
to job in seconds

CarrLane[®]
MANUFACTURING CO.

PUSH/PULL TOGGLE CLAMPS

INFO+: SEE PAGE 439 FOR MATERIAL SPECIFICATIONS



800 lbs

CL-250-SPC (Metric No. CLM-250-SPC)

Heavier clamp with extra plunger height. Locks in extended or retracted position. 1-5/8" plunger travel. Plunger is tapped to accept any 3/8-16 spindle (M10 in metric). Shipping weight 1.9 lbs.

Holding capacity: 800 lbs

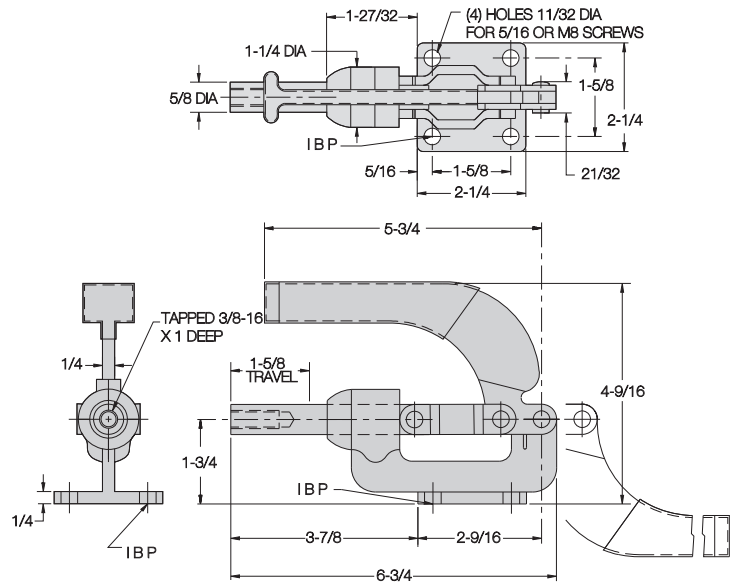

PUSH/PULL TOGGLE CLAMPS

INFO+: SEE PAGE 439 FOR MATERIAL SPECIFICATIONS

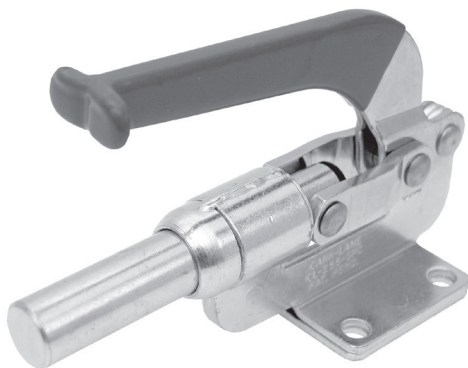

200 lbs
Self-Adjusting
Spring Force

CL-255-SPC

This toggle clamp is the same size as our CL-250-SPC above, and features our patented self-adjusting spring-loaded plunger. The self-adjusting version applies a consistent spring clamping force of 200 lbs (+/- 10%) anywhere within its .20" clamping range. 1-5/8" maximum plunger travel. This version locks only in the "push" direction, and cannot be tapped for a spindle. Optionally available as reverse-acting with a horizontal handle. **Patent no. 6,905,116.** Shipping weight 1.9 lbs.

Spring force (±10%): 200 lbs

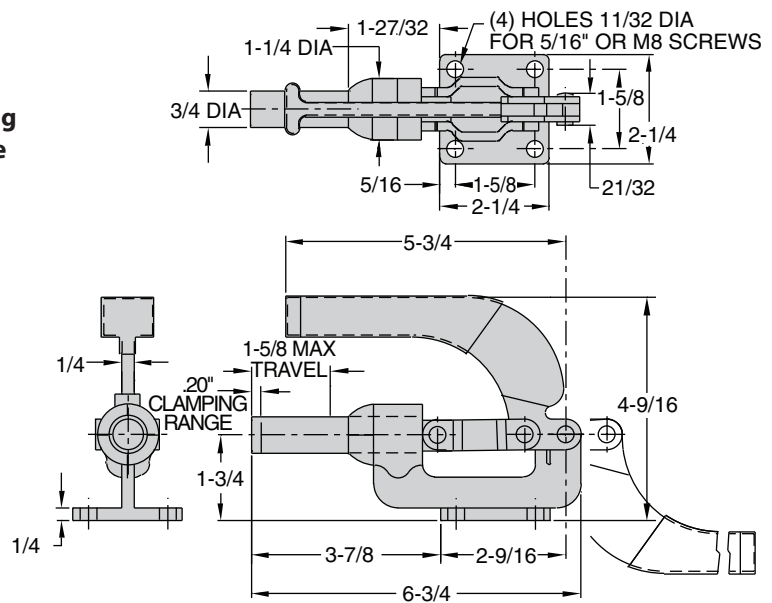

PUSH/PULL TOGGLE CLAMPS

INFO+: SEE PAGE 439 FOR MATERIAL SPECIFICATIONS

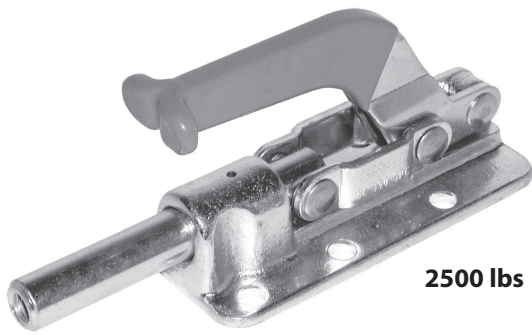

2500 lbs

CL-350-SPC (Metric No. CLM-350-SPC)

Compact heavy-duty plunger clamp with an extremely low profile. Rugged forged steel base. Locks in extended or retracted position. 2" plunger travel. Plunger is tapped to accept any 3/8-16 spindle (M10 in metric). Shipping weight 2.0 lbs.

Holding capacity: 2500 lbs

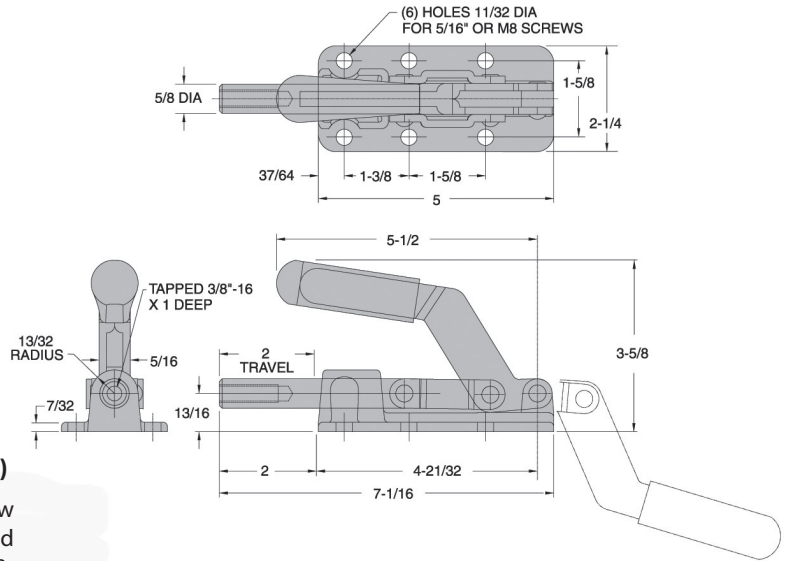

PUSH/PULL TOGGLE CLAMPS

INFO+: SEE PAGE 439 FOR MATERIAL SPECIFICATIONS



2500 lbs
With Safety Lock

CL-350-LSPC

Same as the toggle clamp shown above, except with our unique safety-lock feature. This safety lock automatically engages when the clamp is closed, then remains locked until manually disengaged by pressing the lever before opening. This prevents the clamp from being accidentally opened by bumping the handle. Shipping weight 2.0 lbs.

Holding capacity: 2500 lbs

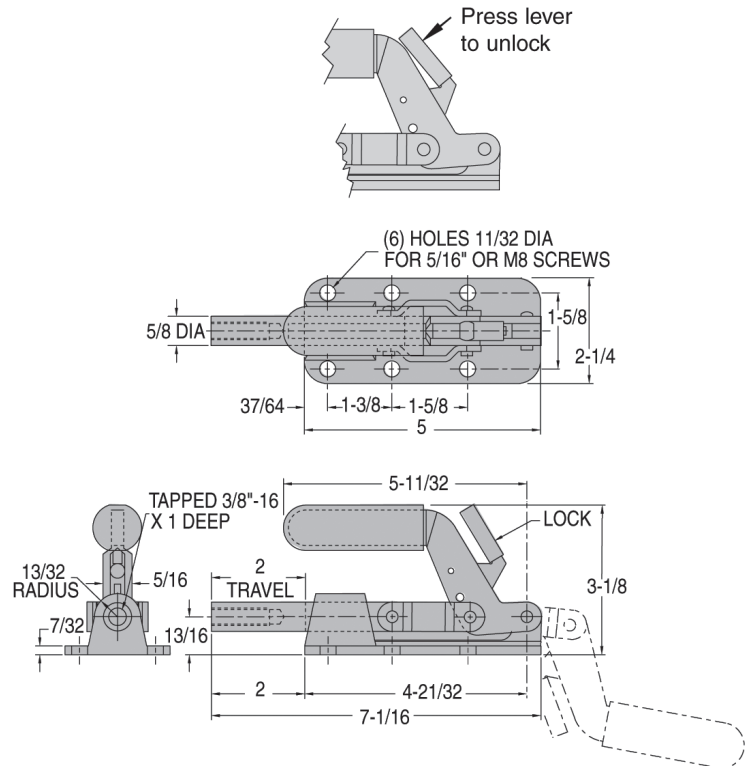

11

PUSH/PULL TOGGLE CLAMPS

INFO+: SEE PAGE 439 FOR MATERIAL SPECIFICATIONS

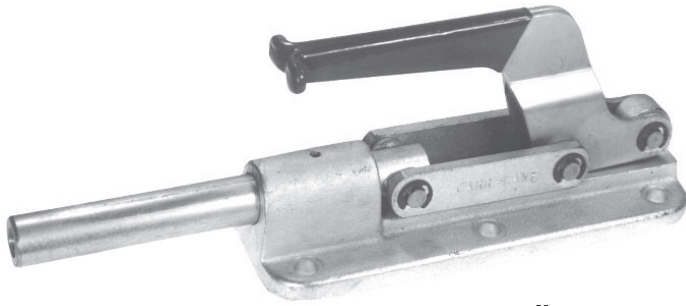

5000 lbs

CL-450-SPC (Metric No. CLM-450-SPC)

Extra-heavy-duty clamp features a full 4" plunger travel! Rugged nodular iron base and a 7/8"-diameter plunger combine to handle the toughest clamping jobs. Locks in extended or retracted position. Plunger is tapped to accept any 1/2-13 spindle (M12 in metric). Shipping weight 7.0 lbs.

Holding capacity: 5000 lbs

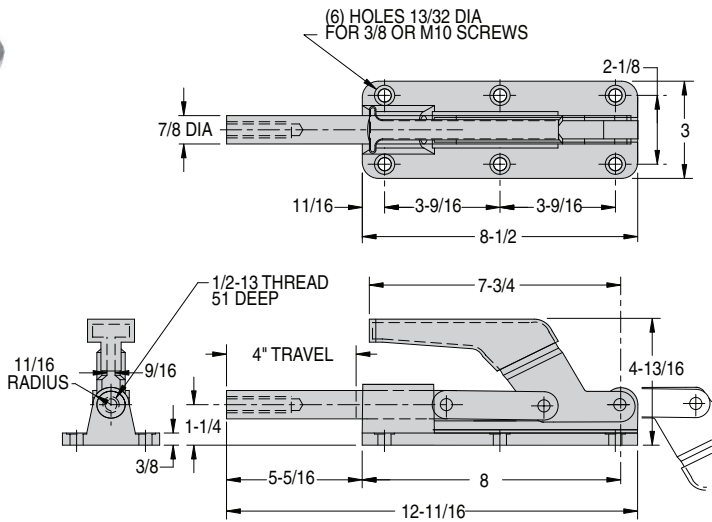

PUSH/PULL TOGGLE CLAMPS

INFO+: SEE PAGE 439 FOR MATERIAL SPECIFICATIONS



16000 lbs

CL-650-SPC (Metric No. CLM-650-SPC)

Strongest plunger clamp available. Handle and base are made of alloy steel. Precision unit with snap-ring pivot pins to allow removing the plunger even after the clamp is mounted. Locks in extended or retracted position. 3" plunger travel. Plunger is tapped to accept any 5/8-11 spindle (M16 in metric). Shipping weight 5.7 lbs.

Holding capacity: 16000 lbs

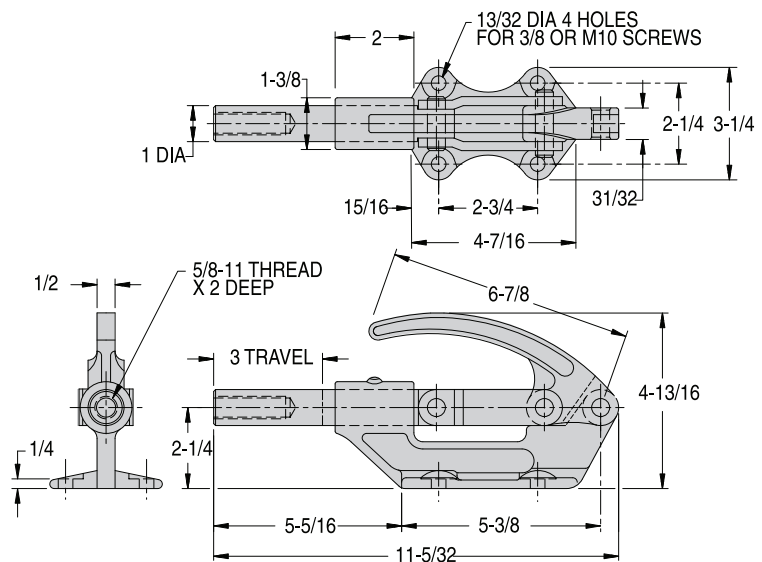

PUSH/PULL TOGGLE CLAMPS

INFO+: SEE PAGE 439 FOR MATERIAL SPECIFICATIONS

600 lbs



CL-275-SPC

(Metric No. CLM-275-SPC)

Similar to CL-250-SPC except with reverse handle action. Plunger advances and locks by moving handle backward into horizontal position. 1-3/16" plunger travel. Plunger is tapped to accept any 3/8-16 spindle (M10 in metric). Straight-base version supplied with separate base bracket to allow mounting clamp at an angle. Shipping weight 1.5 lbs.

Holding capacity:

600 lbs

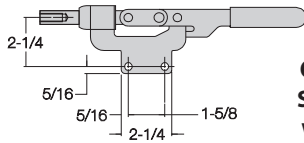

CL-276-SPC
Straight Base
with Bracket

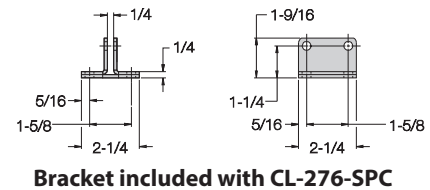
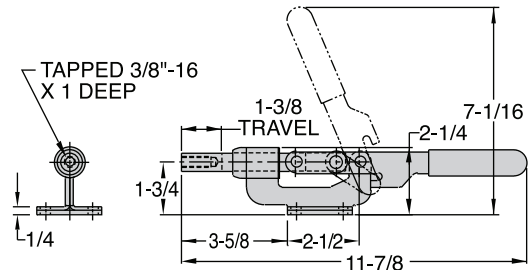
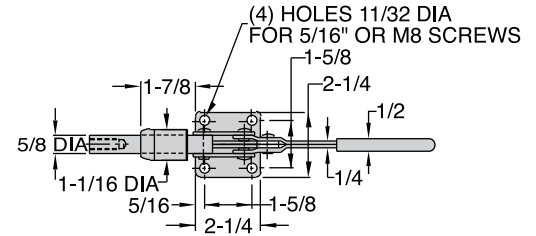

PUSH/PULL TOGGLE CLAMPS

INFO+: SEE PAGE 439 FOR MATERIAL SPECIFICATIONS

200 lbs Spring Force
Self-Adjusting Plunger



CL-285-SPC

This reverse-action toggle clamp is the same size as our CL-275-SPC above, and features our patented self-adjusting spring-loaded plunger. Reverse action advances and locks the plunger by pivoting the handle backward into horizontal position. The self-adjusting version applies a consistent spring clamping force of 200 lbs (+/-10%) anywhere within its .20" clamping range. 1-3/16" maximum plunger travel. This version locks only in the "push" direction, and cannot be tapped for a spindle. Patent no. 6,905,116. Shipping weight 1.5 lbs.

Spring force (±10%):

200 lbs

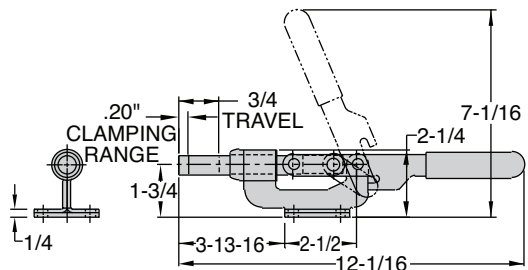
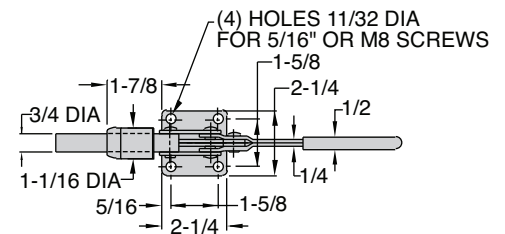

PUSH/PULL TOGGLE CLAMPS

INFO+: SEE PAGE 439 FOR MATERIAL SPECIFICATIONS

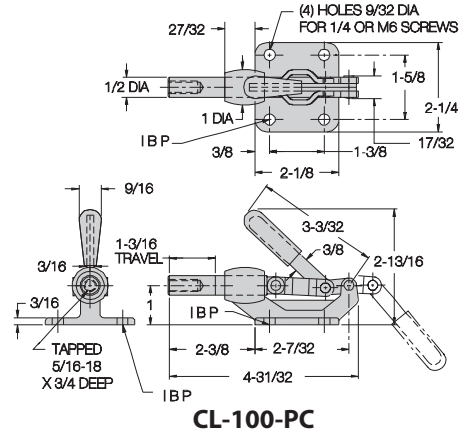
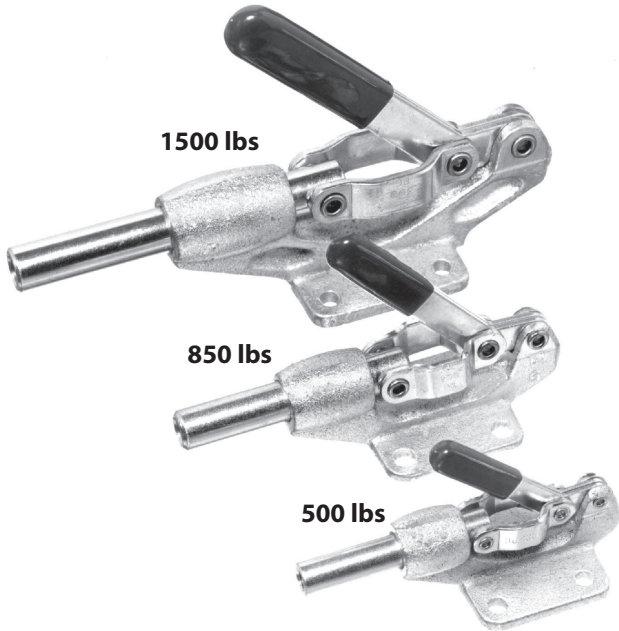

Durable plunger clamp with nodular iron base. Locks in either extended or retracted position. Choice of three sizes.

CL-100-PC (Metric No. CLM-100-PC)

Small-size clamp with 1-3/16" plunger travel. Accepts any 5/16-18 spindle (M8 in metric). Shipping weight 0.9 lbs.

Holding capacity: 500 lbs

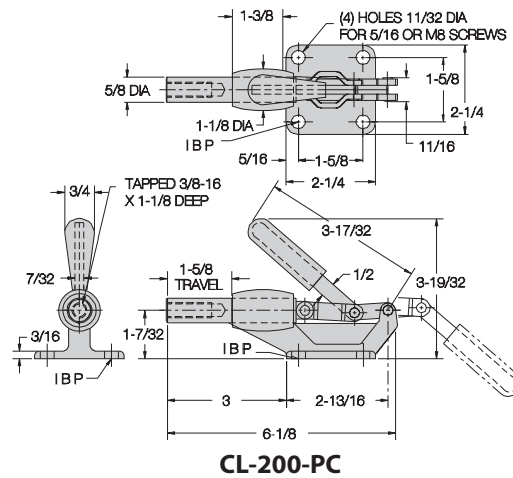

CL-200-PC (Metric No. CLM-200-PC)

Medium-size clamp with 1-5/8" plunger travel. Accepts any 3/8-16 spindle (M10 in metric). Shipping weight 1.4 lbs.

Holding capacity: 850 lbs

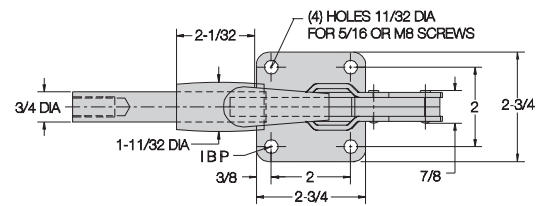

CL-300-PC (Metric No. CLM-300-PC)

Large-size clamp with 2-11/32" plunger travel. Accepts any 1/2-13 spindle (M12 in metric). Shipping weight 3.2 lbs.

Holding capacity: 1500 lbs

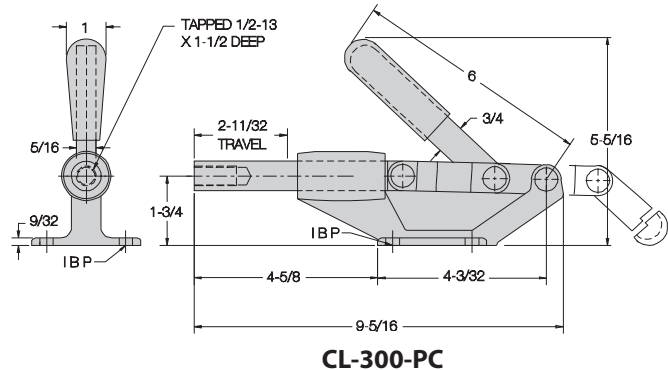

PUSH/PULL TOGGLE CLAMPS

INFO+: SEE PAGE 439 FOR MATERIAL SPECIFICATIONS

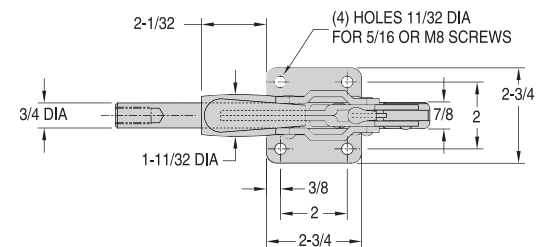
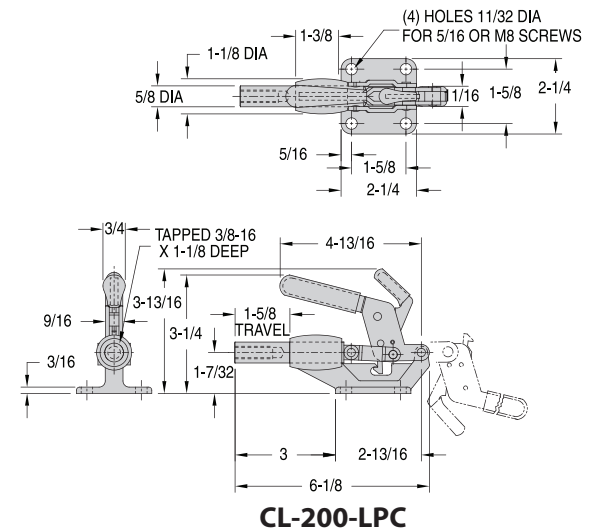
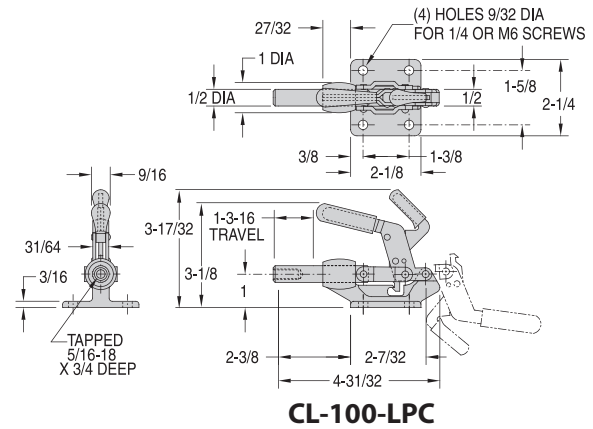
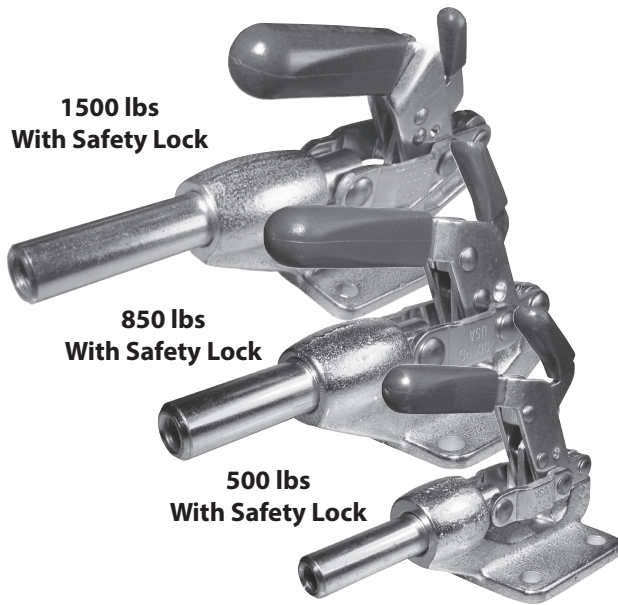

INFO+: Same as the toggle clamps shown on page 484, except with our unique safety-lock feature. This safety lock automatically engages when the clamp is closed, then remains locked until manually disengaged by pressing the lever before opening. This prevents the clamp from being accidentally opened by bumping the handle.

Durable plunger clamp with nodular iron base. Locks in extended or retracted position (safety lock functions only in extended position). Choice of three sizes.

CL-100-LPC

Small-size clamp with 1-3/16" plunger travel. Accepts any 5/16-18 spindle. Shipping weight 0.9 lbs.

Holding capacity: 500 lbs

CL-200-LPC

Medium-size clamp with 1-5/8" plunger travel. Accepts any 3/8-16 spindle. Shipping weight 1.4 lbs.

Holding capacity: 850 lbs

CL-300-LPC

Large-size clamp with 2-11/32" plunger travel. Accepts any 1/2-13 spindle. Shipping weight 3.2 lbs.

Holding capacity: 1500 lbs

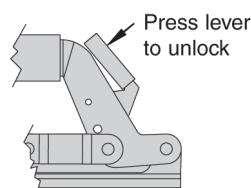

PUSH/PULL TOGGLE CLAMPS

INFO+: SEE PAGE 439 FOR MATERIAL SPECIFICATIONS

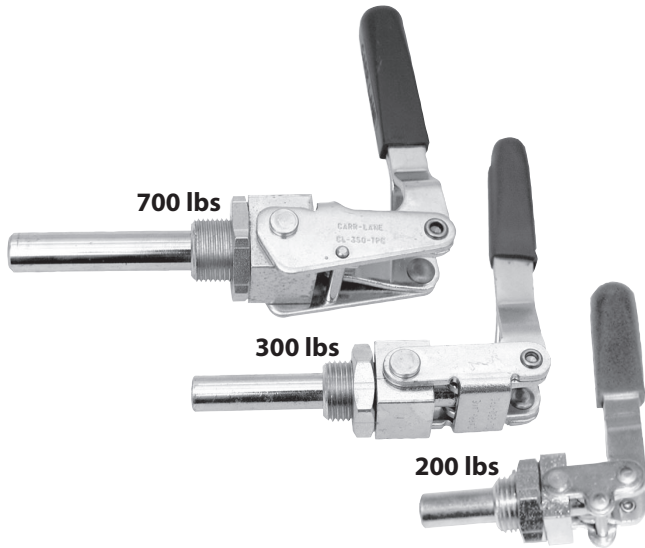

Compact plunger clamps for mounting through panels, plates, or angle brackets. Install in a drilled or tapped hole, securing with the locknut provided. Plunger locks in either extended or retracted position. Rotate clamp to position handle anywhere within 360°. Choice of three sizes.

CL-150-TPC (Metric No. CLM-150-TPC)

Small-size clamp with 3/4" plunger travel. Installs in a 5/8"-diameter drilled hole, or a 5/8-18 tapped hole (M16x1.5 in metric). Accepts any 1/4-20 spindle (M6 in metric). Shipping weight 0.4 lbs.

Holding capacity: 200 lbs

CL-250-TPC (Metric No. CLM-250-TPC)

Medium-size clamp with 1-1/2" plunger travel. Installs in a 3/4"-diameter drilled hole, or a 3/4-16 tapped hole (M20x1.5 in metric). Accepts any 5/16-18 spindle (M8 in metric). Shipping weight 0.7 lbs.

Holding capacity: 300 lbs

CL-350-TPC (Metric No. CLM-350-TPC)

Large-size clamp with 2-5/8" plunger travel. Installs in a 1"-diameter drilled hole, or a 1"-14 (M27x2 in metric) tapped hole. Accepts any 3/8-16 spindle (M10 in metric). Shipping weight 1.5 lbs.

Holding capacity: 700 lbs

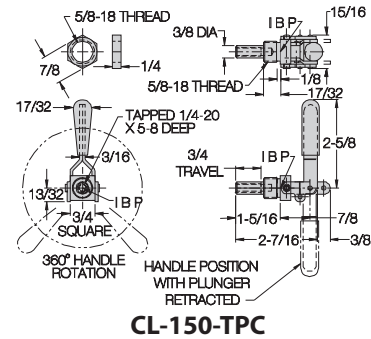

CL-150-TPC

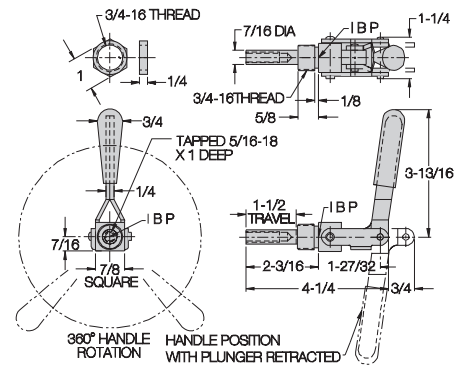

CL-250-TPC

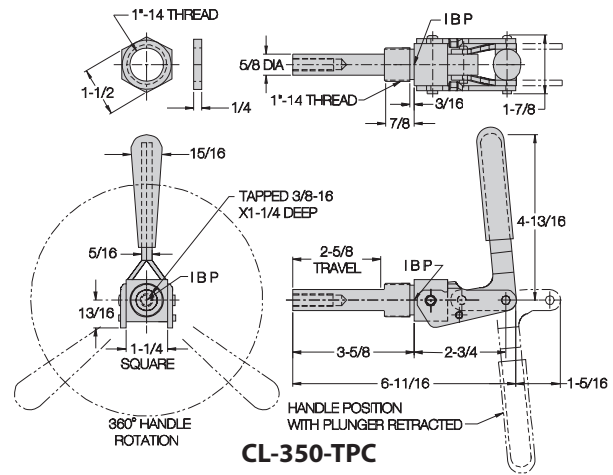

CL-350-TPC

Mounting Bracket for CL-250-TPC:

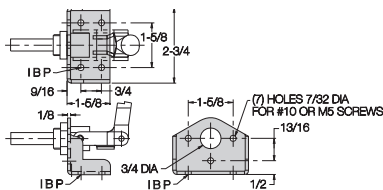

CL-250-TPCA

Also available in stainless steel...



CL-150-TPC-S
200 lbs

CL-250-TPC-S
300 lbs

CL-350-TPC-S
700 lbs

PUSH/PULL TOGGLE CLAMPS

INFO+: SEE PAGE 439 FOR MATERIAL SPECIFICATIONS

**200 lbs Spring Force
Self-Adjusting Plunger**



**100 lbs Spring Force
Self-Adjusting Plunger**

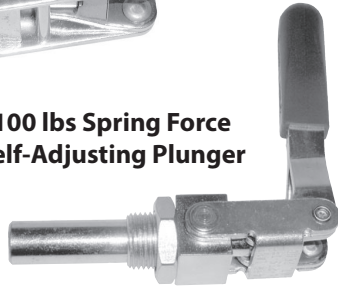

These toggle clamps are the same size as our CL-250-TPC and CL-350-TPC on the opposite page, and feature our patented self-adjusting spring-loaded plunger. The self-adjusting version applies a consistent spring clamping force anywhere within its clamping range. This version locks only in the "push" direction, and cannot be tapped for a spindle. Compact plunger clamps for mounting through panels, plates, or angle brackets. Install in a drilled or tapped hole, securing with the locknut provided. Rotate clamp to position handle anywhere within 360°. **Patent no. 6,905,116.** Choice of two sizes.

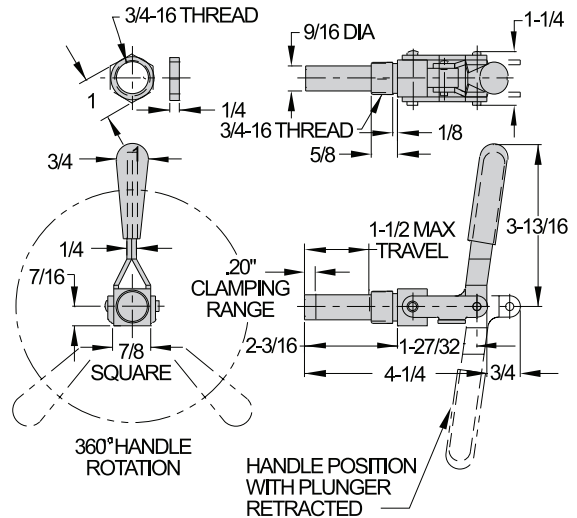

CL-255-TPC

CL-255-TPC

This medium-size self-adjusting clamp applies a consistent spring clamping force of 100 lbs (+/-10%) anywhere within its .20" clamping range. 1-1/2" maximum plunger travel. Installs in a 3/4"-diameter drilled hole, or a 3/4-16 tapped hole. Shipping weight 0.7 lbs.

Spring force (±10%): 100 lbs

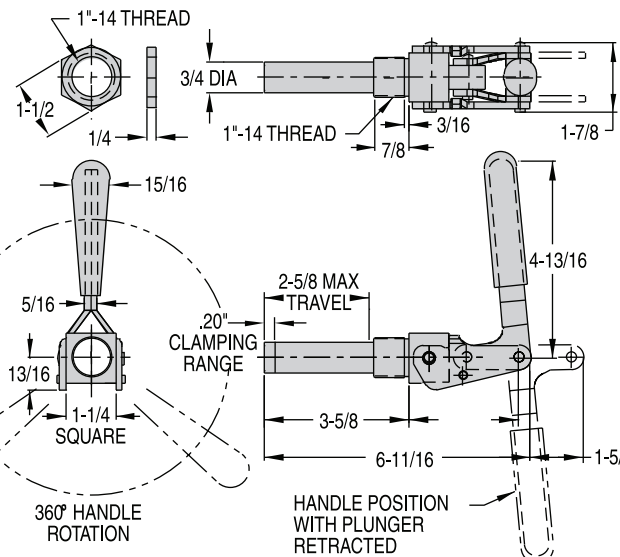

CL-355-TPC

CL-355-TPC

This large-size self-adjusting clamp applies a consistent spring clamping force of 200 lbs (+/-10%) anywhere within its .20" clamping range. 2-5/8" maximum plunger travel. Installs in a 1"-diameter drilled hole, or a 1"-14 tapped hole. Shipping weight 1.5 lbs.

Spring force (±10%): 200 lbs

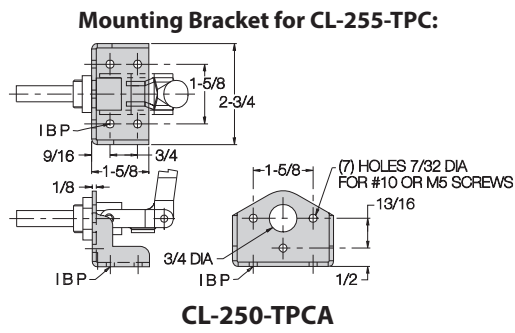

LATCH-ACTION TOGGLE CLAMPS

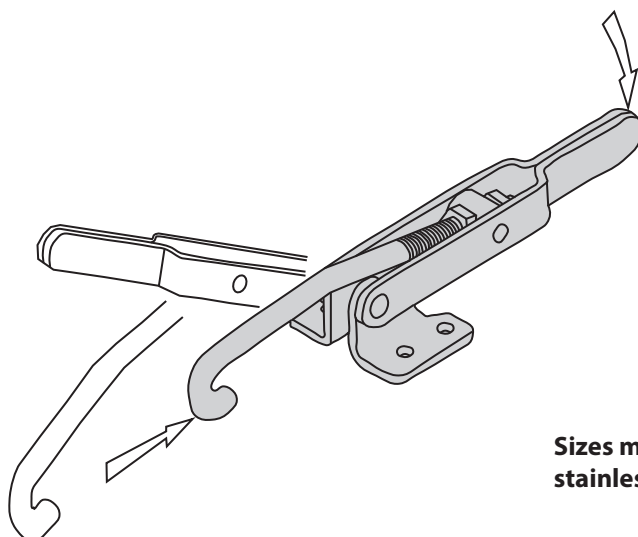

Sizes marked * are also available in stainless steel

All Carr Lane Manufacturing toggle clamps are DFARS and RoHS compliant.

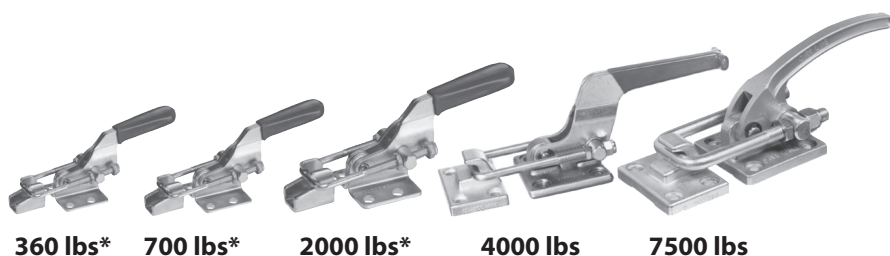

360 lbs* 700 lbs* 2000 lbs* 4000 lbs 7500 lbs

Adjustable U Bolt p. 489-493

Latch-action clamp with a threaded U bolt for adjustability. Supplied with matching latch plate (smallest three sizes). Large, comfortable handle grip. Available in five sizes.



500 lbs* 1000 lbs* 2000 lbs*

Right-Angle Adjustable U Bolt p. 494

Similar to the latch clamp above, except with its pulling direction perpendicular to the base. Supplied with matching latch plate. Large, comfortable handle grip. Available in three sizes.



375 lbs* 1000 lbs

Adjustable Hook p. 489

Popular hook-type latch clamp. Hook is threaded at one end for easy adjustment. Base rotates 90° to allow horizontal or vertical latching. Available in two sizes.



375 lbs*

Fixed Length p. 495

Latch clamp with fixed reach for installation where no length adjustment is required. Adjustable stop allows latching at different heights.

LATCH-ACTION TOGGLE CLAMPS

INFO+: SEE PAGE 439 FOR MATERIAL SPECIFICATIONS

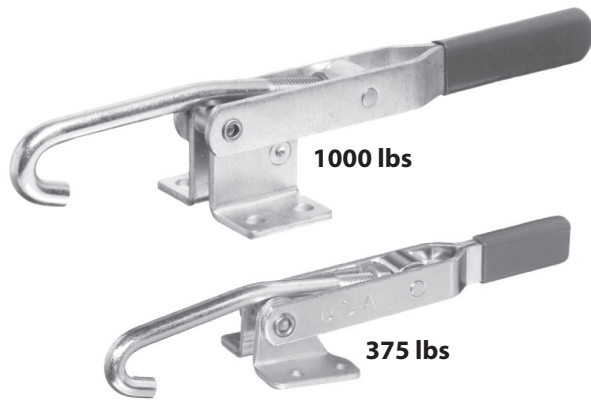

Latch clamp with a versatile hook for grasping a rod or rim. Hook is threaded at one end to allow adjustment after mounting. Base pivots to allow horizontal or vertical latching. Choice of two sizes. Optional latch plate can be mounted as shown in the drawings, or reversed, for mounting flexibility.

CL-250-PA

Medium-size latch clamp with a 4-inch drawing movement. Threaded hook allows a 5/16-inch adjustment range. Shipping weight 0.8 lbs. Order matching latch plate CL-250-PA-L separately (CL-250-PA-S-L in stainless).

Holding capacity: 375 lbs

CL-350-PA

Large-capacity latch clamp with 6-1/8-inch drawing movement. Threaded hook allows a 3/4-inch adjustment range. Shipping weight 2.5 lbs. Order matching latch plate CL-350-PA-L separately.

Holding capacity: 1000 lbs



CL-257-PA

Same as CL-250-PA except with a manual safety lock. Push knob in to lock, pull knob out to unlock.

Holding capacity: 375 lbs

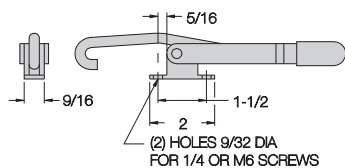
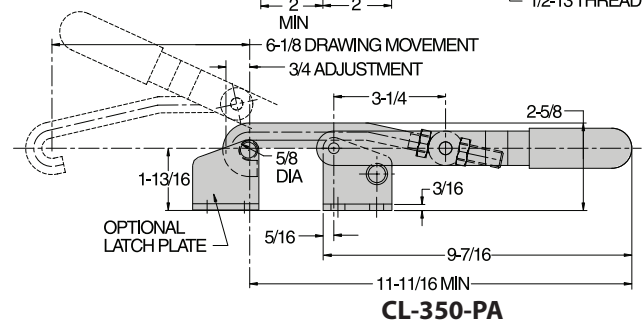
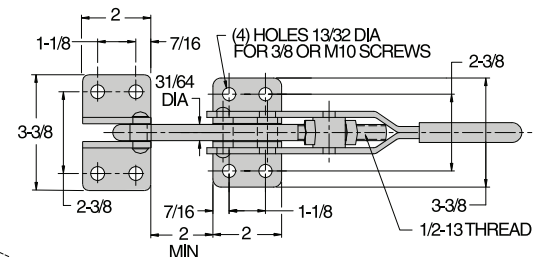
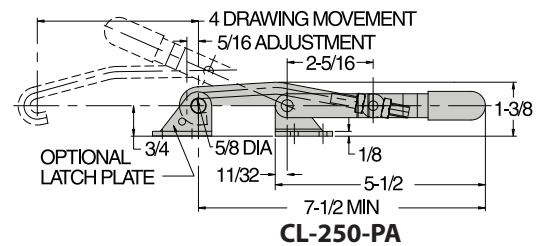
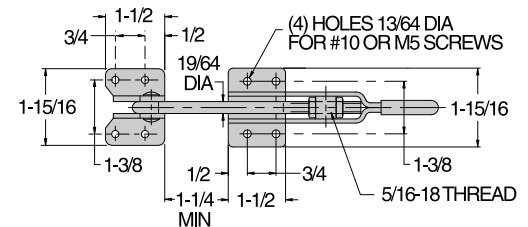
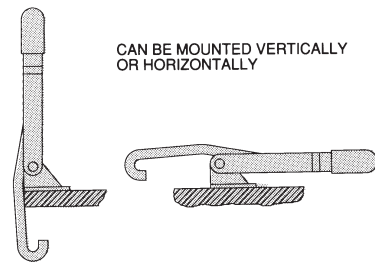

CL-251-PA
Narrow Base
375 lbs

Also available in stainless steel ...



CL-250-PA-S

Extra hooks available ...



CL-250-PA-HOOK
CL-250-PA-S-HOOK
CL-350-PA-HOOK

LATCH-ACTION TOGGLE CLAMPS

INFO+: SEE PAGE 439 FOR MATERIAL SPECIFICATIONS

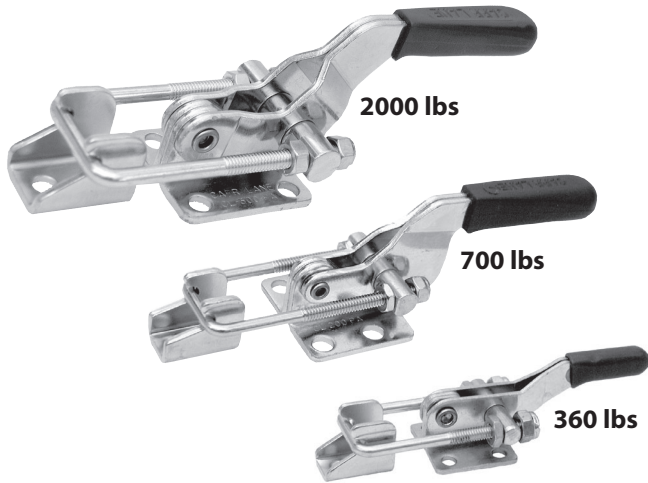

Versatile latch clamp with a threaded U bolt for adjustability. Supplied with matching latch plate. Large, comfortable handle grip. Available in three sizes (INFO+: See page 505 for two larger sizes).

CL-100-PA

Miniature latch clamp with high holding capacity. 1-3/16-inch drawing movement. Threaded U bolt allows a 25/64-inch adjustment range. Shipping weight 0.2 lbs.

Holding capacity: 360 lbs

CL-200-PA

Medium-size latch clamp with 2-inch drawing movement. Threaded U bolt allows a 3/8-inch adjustment range. Shipping weight 0.4 lbs.

Holding capacity: 700 lbs

CL-300-PA

Heavy-duty latch clamp. Well-suited for applications such as plastic molding. 2-1/2-inch drawing movement. Threaded U bolt allows a 15/16-inch adjustment range. Shipping weight 1.5 lbs.

Holding capacity: 2000 lbs

Also available in stainless steel...

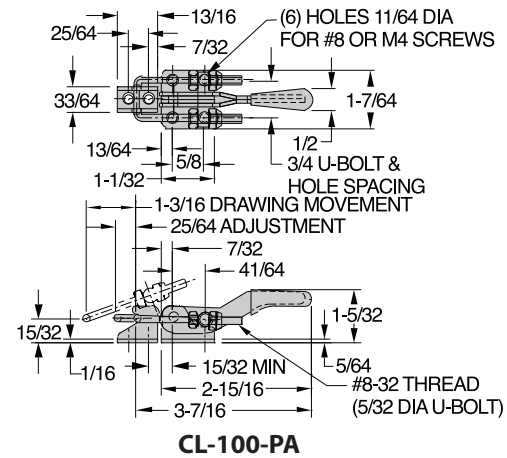

CL-100-PA

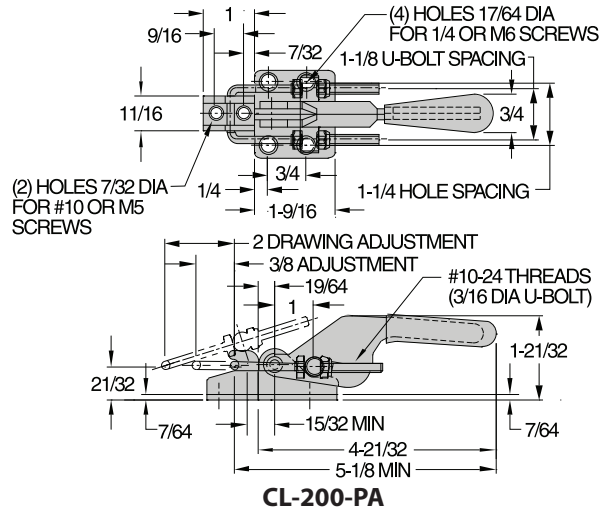

CL-200-PA

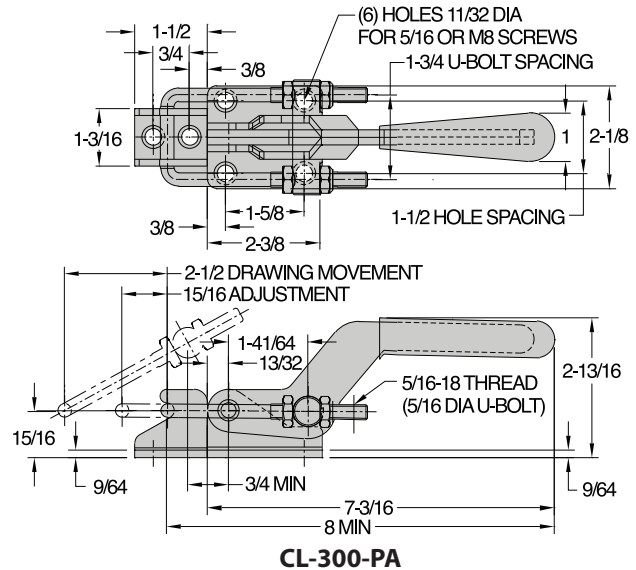

CL-300-PA

LATCH-ACTION TOGGLE CLAMPS

INFO+: SEE PAGE 439 FOR MATERIAL SPECIFICATIONS

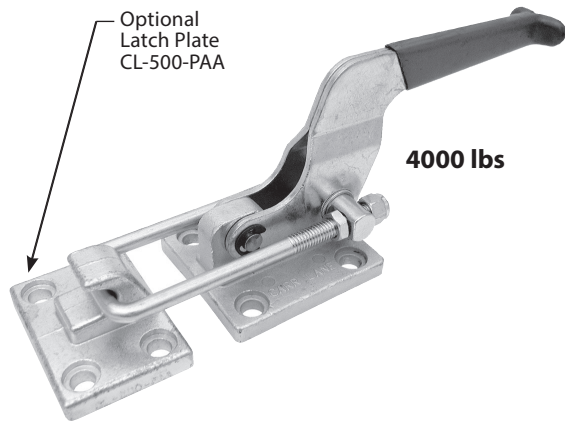

CL-400-PA

INFO+: Heavier-duty version of the latch clamps on page 516. Strong enough to resist the high expansion forces generated in polyurethane molds. Rugged alloy steel base and latch plate (order latch plate separately). Threaded U bolt allows a 3/4-inch adjustment range. 2-7/16" drawing movement. Shipping weight 2.8 lbs.

Holding capacity:

4000 lbs

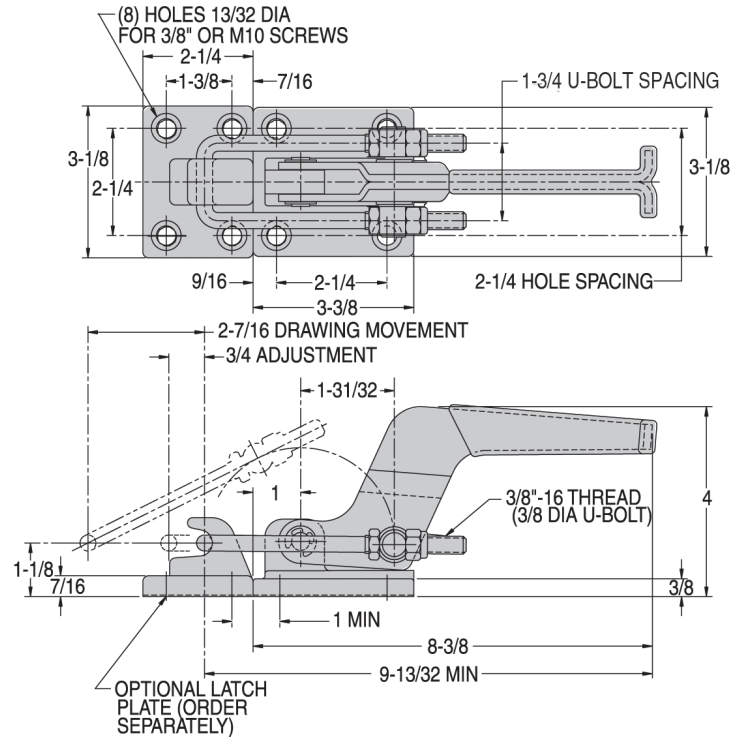

LATCH-ACTION TOGGLE CLAMPS

INFO+: SEE PAGE 439 FOR MATERIAL SPECIFICATIONS

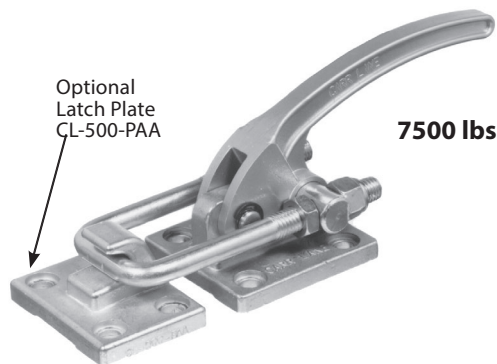

CL-500-PA

Strongest latch clamp available. Alloy steel handle provides even greater strength than the CL-400-PA above, yet with a more-compact overall size. Rugged alloy steel base and latch plate (order latch plate separately). Threaded U bolt allows a 1-1/8-inch adjustment range. 1-3/8" drawing movement. Shipping weight 3.3 lbs.

Holding capacity:

7500 lbs

Also available in stainless steel...

CL-500-PA-S (Clamp)

CL-500-PAA-S (Latch Plate)

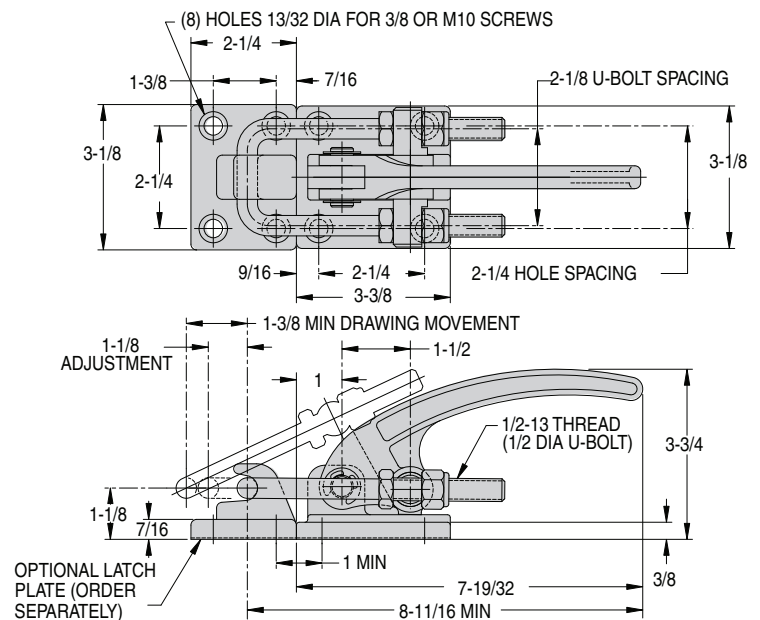
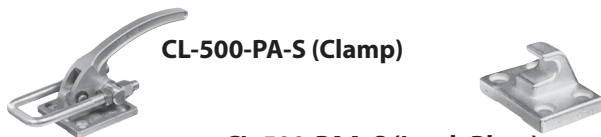

LATCH-ACTION TOGGLE CLAMPS

INFO+: SEE PAGE 439 FOR MATERIAL SPECIFICATIONS

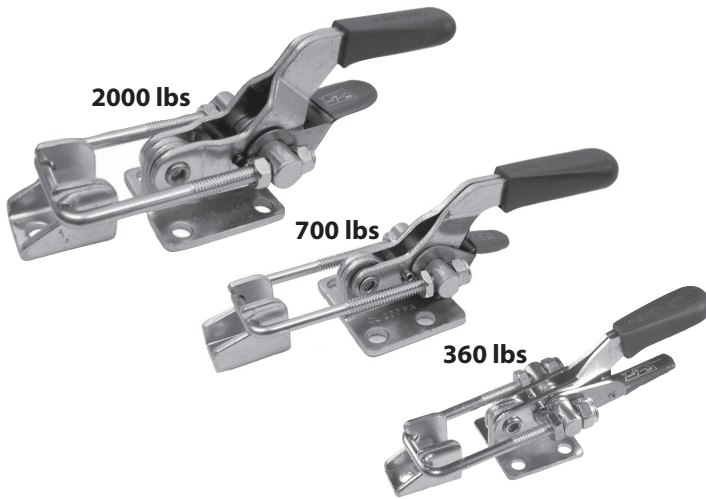

INFO+: Same as our latch clamps on page 491 except with safety-lock feature. This safety lock automatically engages when the clamp is closed, then remains locked until manually disengaged by pressing the lever before opening. This prevents the latch clamp from being accidentally opened by bumping the handle.

Versatile latch clamp with a threaded U bolt for adjustability. Supplied with matching latch plate. Large, comfortable handle grip. Available in two sizes.

CL-100-LPA

Miniature latch action clamp with high holding capacity. 1-3/16-inch drawing movement. Threaded U bolt allows a 25/64-inch adjustment range. Shipping weight 0.2 lbs.

Holding capacity: 360 lbs

CL-200-LPA

Medium-size latch clamp with 2-inch drawing movement. Threaded U bolt allows a 3/8-inch adjustment range. Shipping weight 0.4 lbs.

Holding capacity: 700 lbs

CL-300-LPA

Heavy-duty latch clamp. Well-suited for applications such as plastic molding. 2-1/2-inch drawing movement. Threaded U bolt allows a 15/16-inch adjustment range. Shipping weight 1.5 lbs.

Holding capacity: 2000 lbs

Also available in stainless steel...

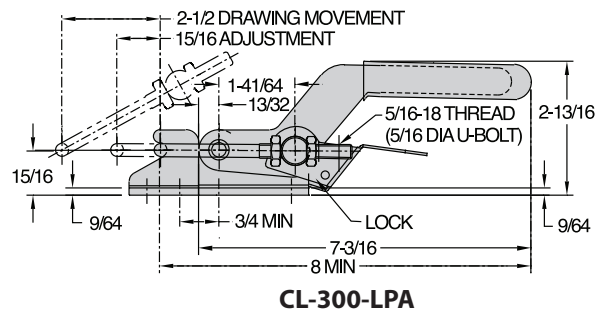
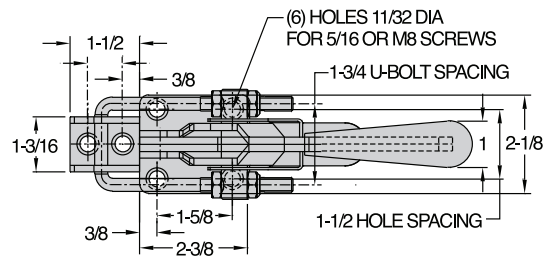
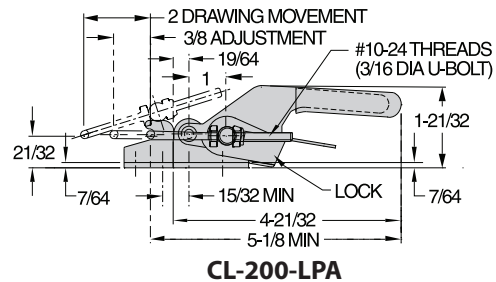
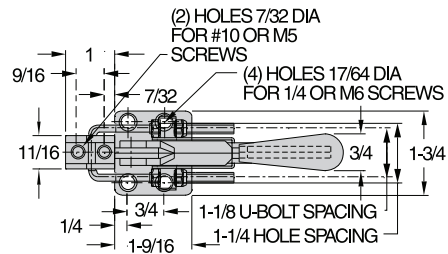
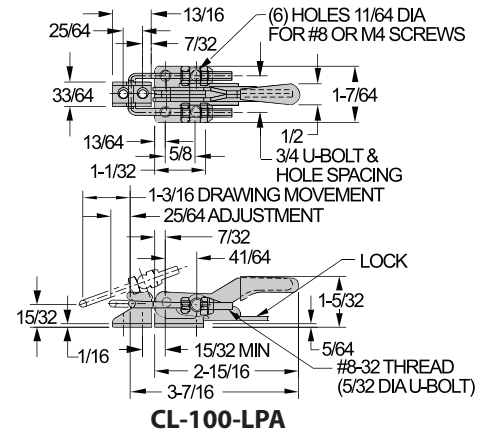

LATCH-ACTION TOGGLE CLAMPS

INFO+: SEE PAGE 439 FOR MATERIAL SPECIFICATIONS

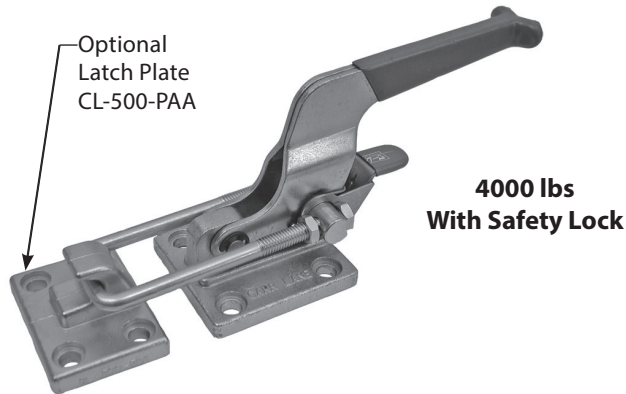

**4000 lbs
With Safety Lock**

CL-400-LPA

INFO+: Same as our latch clamps on page 491 except with our unique safety-lock feature. This safety lock automatically engages when the clamp is closed, then remains locked until manually disengaged by pressing the lever before opening. This prevents the latch clamp from being accidentally opened by bumping the handle. Rugged alloy steel base and latch plate (order latch plate separately). Threaded U bolt allows a 3/4-inch adjustment range. 2-7/16" drawing movement. Shipping weight 2.8 lbs.

Holding capacity:

4000 lbs

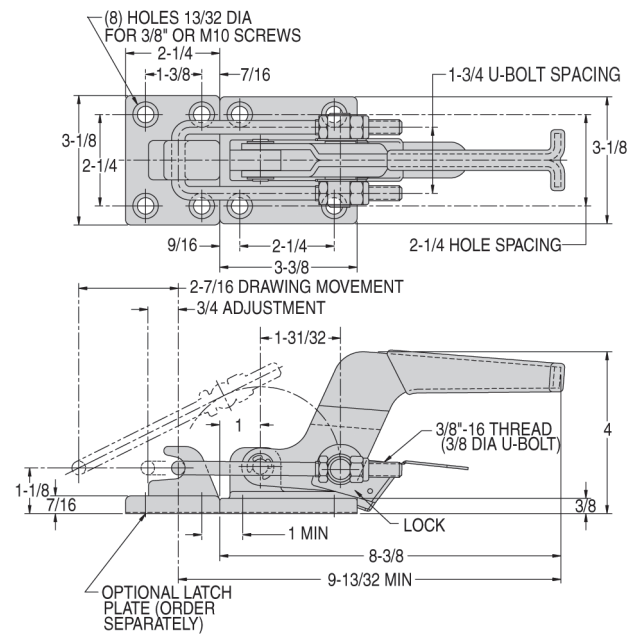
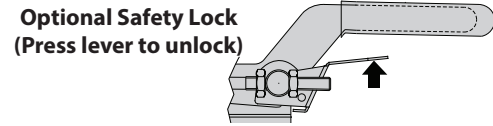

LATCH-ACTION TOGGLE CLAMPS

INFO+: SEE PAGE 439 FOR MATERIAL SPECIFICATIONS

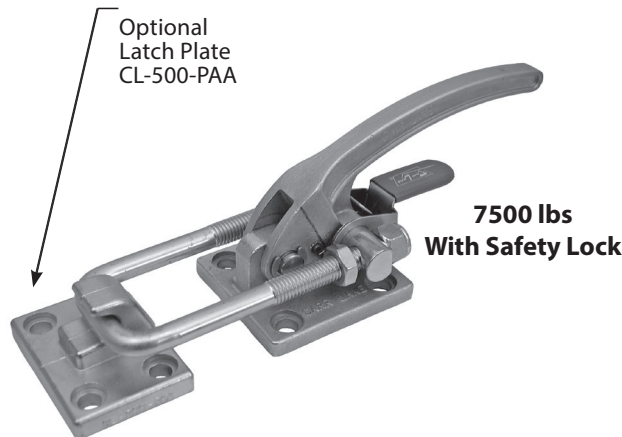

**7500 lbs
With Safety Lock**

CL-500-LPA

INFO+: Same as our latch clamps on page 491 except with our unique safety-lock feature. This safety lock automatically engages when the clamp is closed, then remains locked until manually disengaged by pressing the lever before opening. This prevents the latch clamp from being accidentally opened by bumping the handle. Rugged alloy steel base and latch plate (order latch plate separately). Threaded U bolt allows a 1-1/8-inch adjustment range. 1-3/8" drawing movement. Shipping weight 3.3 lbs.

Holding capacity:

7500 lbs

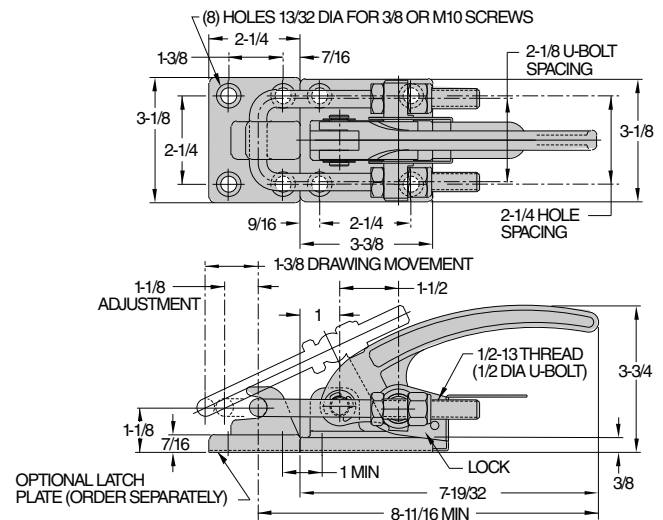

Also available in stainless steel...

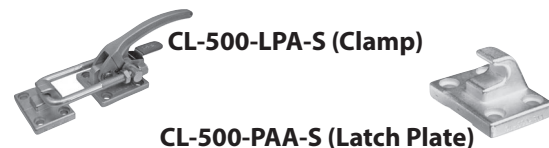

11

LATCH-ACTION TOGGLE CLAMPS

INFO+: SEE PAGE 439 FOR MATERIAL SPECIFICATIONS

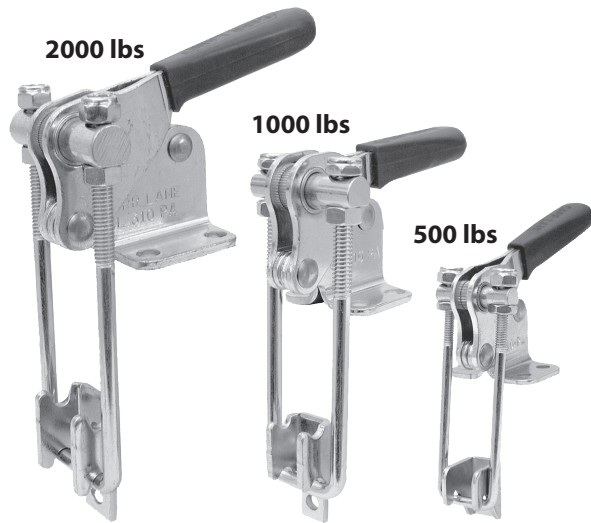

INFO+: Similar to the adjustable-U-bolt latch clamps on page 491, except with their pulling direction perpendicular to the base. Supplied with matching latch plate. Large, comfortable handle grip. Available in three sizes.

CL-110-PA

Miniature latch clamp with high holding capacity. 1-1/2-inch drawing movement. Threaded U bolt allows a 7/16-inch adjustment range. Shipping weight 0.3 lbs.

Holding capacity: 500 lbs

CL-210-PA

Medium-size latch clamp with 2-1/16-inch drawing movement. Threaded U bolt allows an 11/16-inch adjustment range. Shipping weight 0.6 lbs.

Holding capacity: 1000 lbs

CL-310-PA

Heavy-duty latch clamp. Well-suited for applications such as plastic molding. 2-1/2-inch drawing movement. Threaded U bolt allows an 1-1/8-inch adjustment range. Shipping weight 1.4 lbs.

Holding capacity: 2000 lbs

Also available in stainless steel . . .

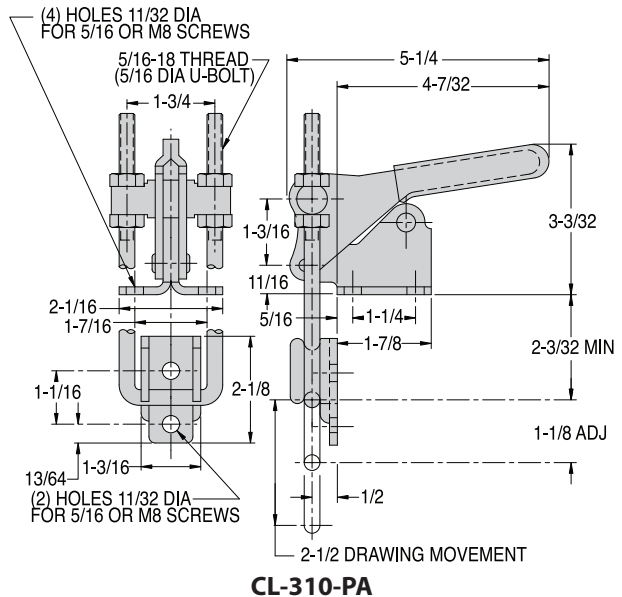
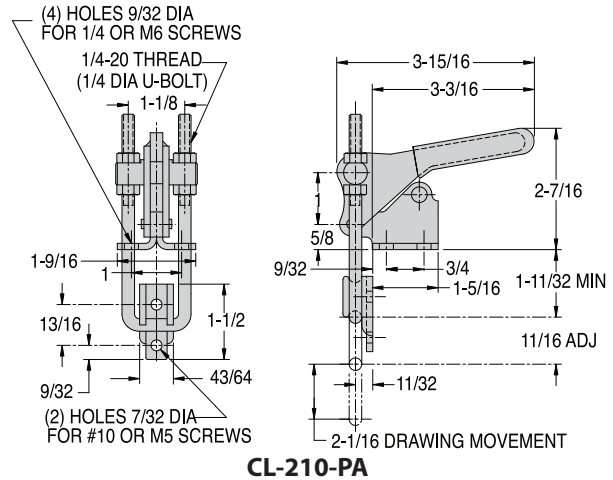
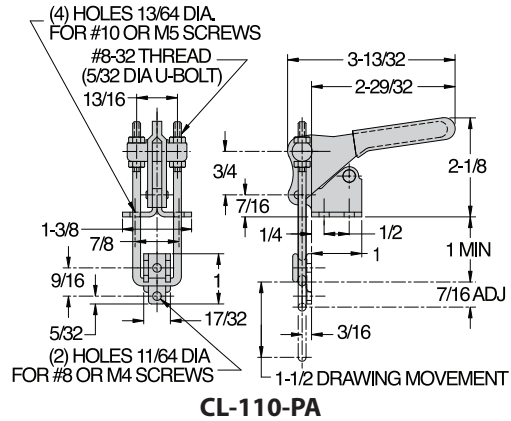

LATCH-ACTION TOGGLE CLAMPS

INFO+: SEE PAGE 439 FOR MATERIAL SPECIFICATIONS

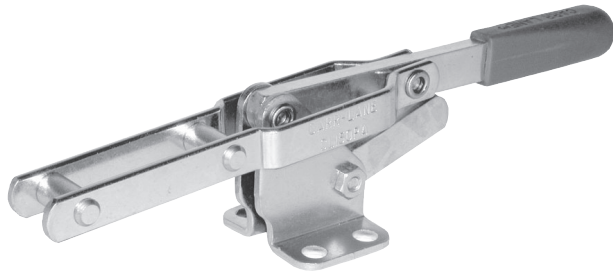

375 lbs

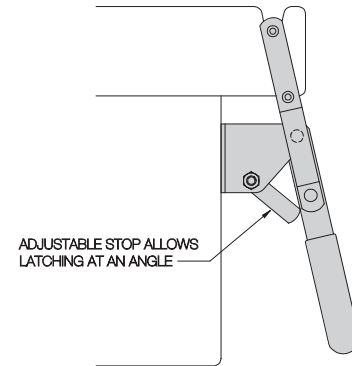

Latch clamp with fixed reach for installation where no length adjustment is required. An adjustable stop allows latching at different angles.

CL-150-PA

Medium-size clamp with 4-inch drawing movement. Shipping weight 0.8 lbs.

Holding capacity:

375 lbs

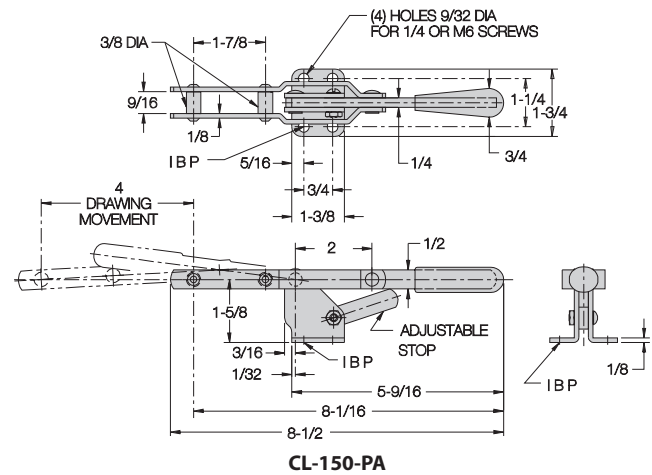

Also available in stainless steel...



CL-150-PA-S

TOGGLE PLIERS

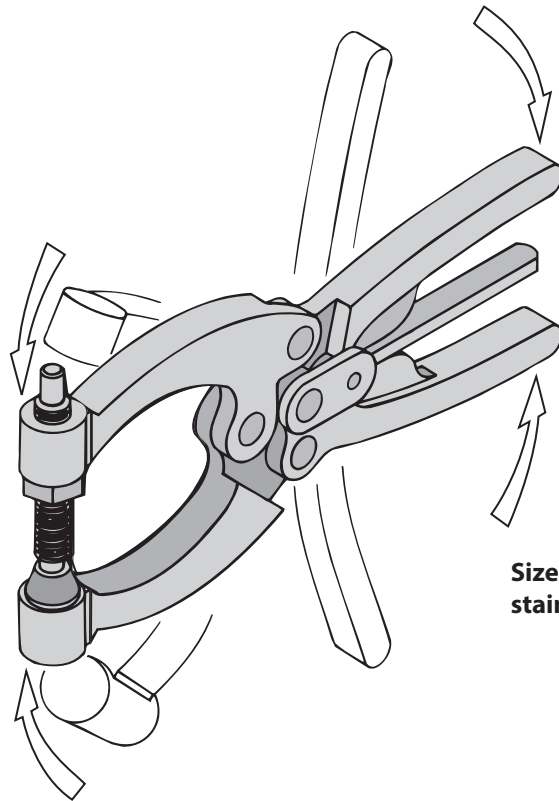

Sizes marked * are also available in stainless steel

All Carr Lane Manufacturing toggle clamps are DFARS and RoHS compliant.



200 lbs 350 lbs 700 lbs 700 lbs 700 lbs

Forged Toggle Pliers p. 497-499

Powerful forged steel toggle pliers. Available in five sizes. Larger sizes feature a quick-release lever for easy opening.



800 lbs*

Permanently Attached p. 500

Handy weld-on/bolt-on clamp for holding down lids, covers etc. Clamping jaw opens a full 90° for extra clearance.

TOGGLE PLIERS

INFO+: SEE PAGE 439 FOR MATERIAL SPECIFICATIONS



200 lbs

CL-50-PL

Tiny-yet-powerful toggle pliers made of forged steel. 1-inch jaw width. Supplied with 1/4-20 vinyl-coated hex-head spindle CL-14208-SA. Optionally available as CL-50-PL-2 with a bottom-jaw cushion, or as CL-50-PL-3 with (2) vinyl-coated hex-head spindles, CL-14100-SA. Shipping weight 0.4 lbs.

Holding capacity: 200 lbs

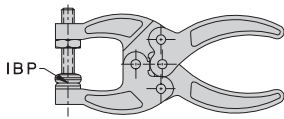
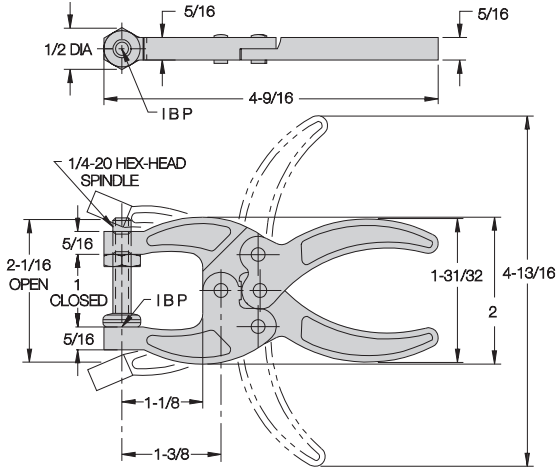

CL-50-PL-2
Hex-Head Spindle
and Bottom Cushion

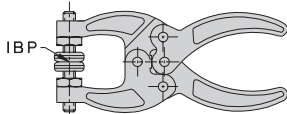

CL-50-PL-3
Dual Hex-Head Spindle

TOGGLE PLIERS

INFO+: SEE PAGE 439 FOR MATERIAL SPECIFICATIONS



350 lbs

CL-150-PL

Medium-size toggle pliers made of forged steel. 1-1/4-inch jaw width. Supplied with 5/16-18 hex-head spindle CL-516212-SA. Shipping weight 0.5 lbs.

Holding capacity: 350 lbs

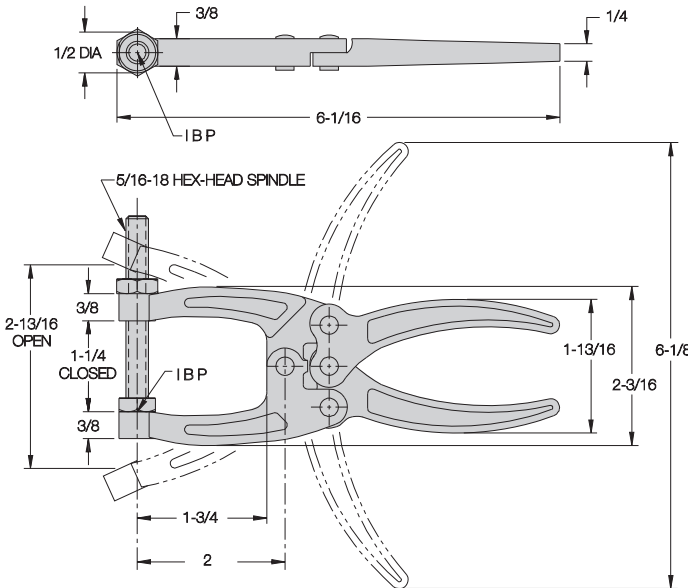

11

TOGGLE PLIERS

INFO+: SEE PAGE 439 FOR MATERIAL SPECIFICATIONS



700 lbs

CL-254-PL

Heavy-duty toggle pliers made of forged steel. 1-3/4 inch jaw width. Two-way quick-release lever for easy opening. Supplied with 3/8-16 swivel-foot spindle CL-38314-SF. Optionally available as CL-250-PL with hex-head spindle CL-38314-SA, as CL-254-PL-2 with (2) hex-head spindles CL-38314-SA, or as CL-252-PL with flat-cushion spindle CL-38314-FC. Shipping weight 1.3 lbs.

Holding capacity:

700 Lbs

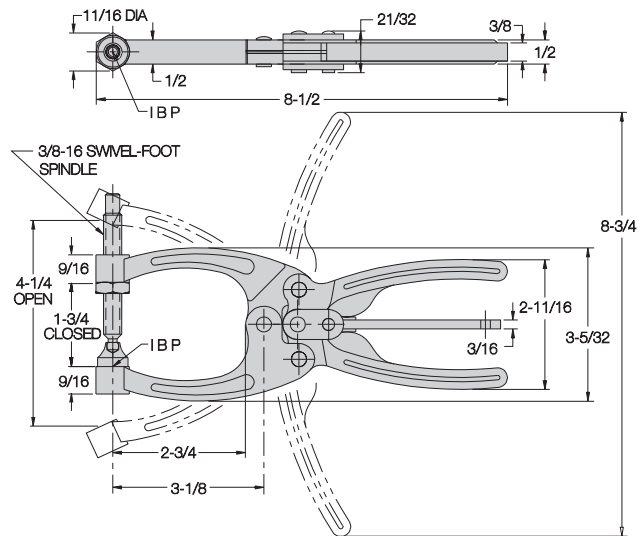

11

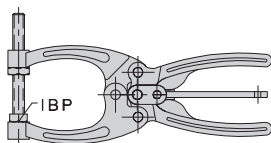

CL-250-PL
Hex-Head Spindle

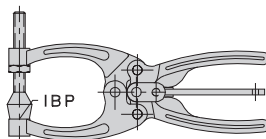

CL-252-PL
Flat Cushion Spindle

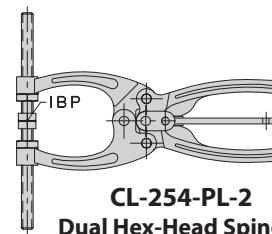

CL-254-PL-2
Dual Hex-Head Spindle

TOGGLE PLIERS

INFO+: SEE PAGE 439 FOR MATERIAL SPECIFICATIONS

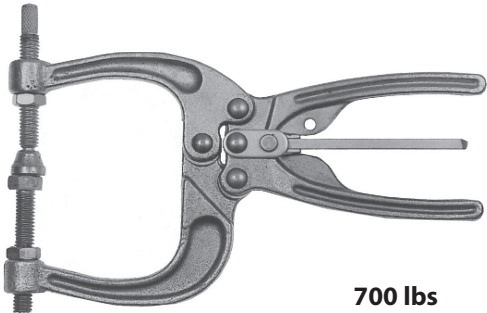

700 lbs

CL-454-PL

Wide-jaw heavy-duty toggle pliers made of forged steel. 3-inch jaw width. Two-way quick-release lever for easy opening. Supplied with 3/8-16 swivel-foot spindle CL-38314-SF and hex-head spindle CL-38314-SA. Shipping weight 1.4 lbs.

Holding capacity: **700 lbs**

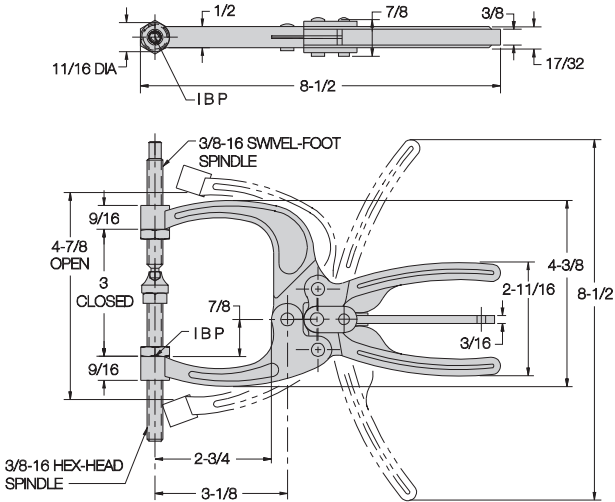

TOGGLE PLIERS

INFO+: SEE PAGE 439 FOR MATERIAL SPECIFICATIONS

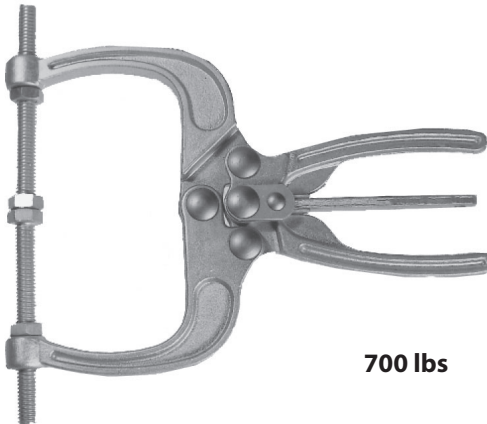

700 lbs

CL-550-PL

Extra-wide-jaw heavy-duty toggle pliers made of forged steel. 4-1/4-inch jaw width. Two-way quick-release lever for easy opening. Supplied with (2) 3/8-16 hex-head spindles CL-38314-SA. Shipping weight 1.6 lbs.

Holding capacity: **700 lbs**

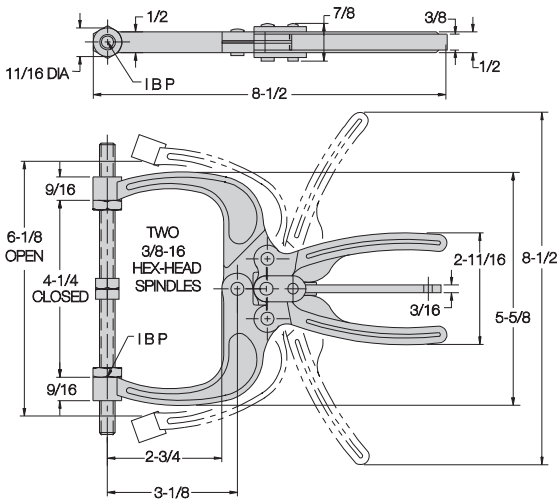

11

TOGGLE PLIERS

INFO+: SEE PAGE 439 FOR MATERIAL SPECIFICATIONS



**800 lbs
Stainless**

CL-325-PL-S

Handy weld-on/bolt-on stainless steel clamp for holding down lids, covers, etc. Clamping jaw opens a full 90° for extra clearance, while handle moves 50°. Supplied with 1/2-13 stainless hex-head spindle CL-12234-SA-S. Shipping weight 1.0 lbs.

Holding capacity:

800 lbs

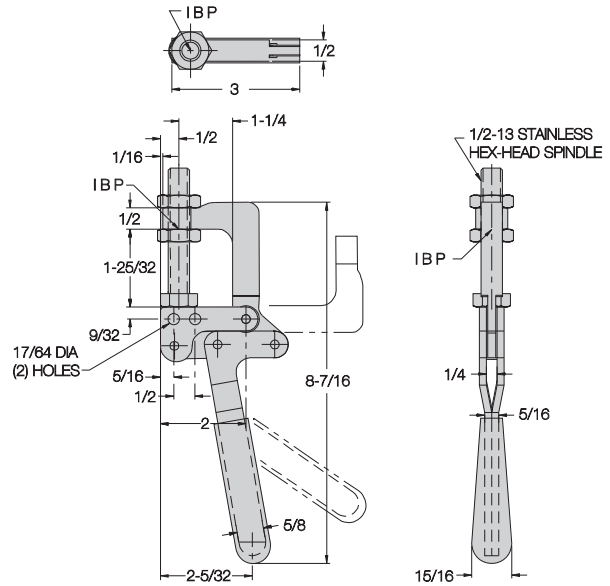

Need to configure a part? Try our
Part Configurator

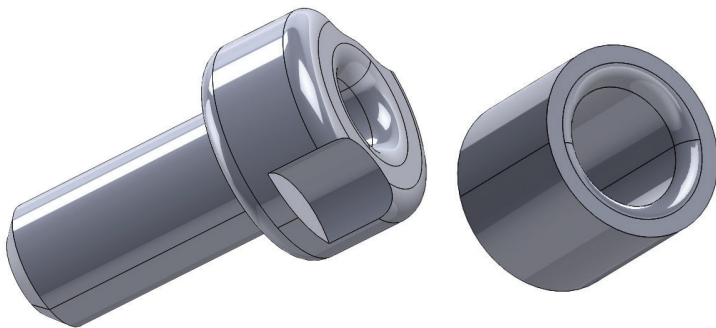

**Start Configuring
Parts Today!**

CarrLane
MANUFACTURING CO.

carrlane.com/configured-parts

AIR-POWERED CLAMPS

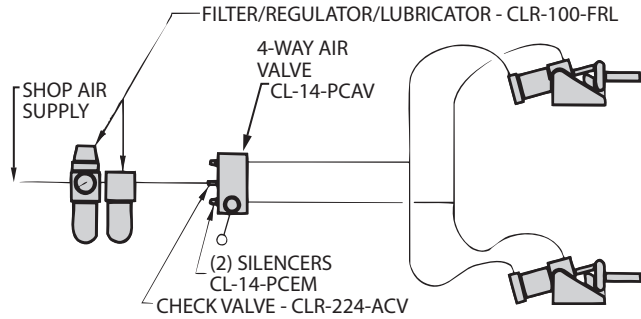
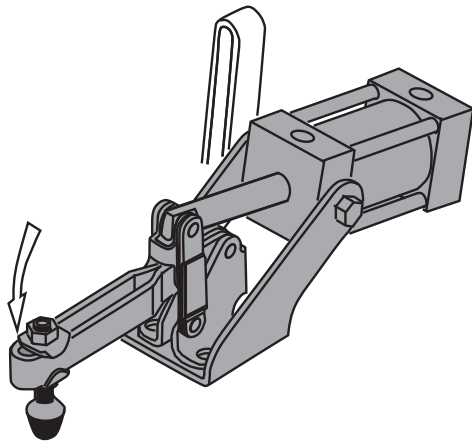

All Carr Lane Manufacturing toggle clamps are DFARS and RoHS compliant.

Toggle Hold-Down Clamps p. 502-506

Similar to a vertical-handle hold-down clamp, except linkage is operated by a double-acting air cylinder instead of by hand. Toggle linkage provides high holding capacity and insures positive mechanical locking even if air pressure fails. Complete selection of accessories including clamping valves, check valves, exhaust mufflers, and air fittings.

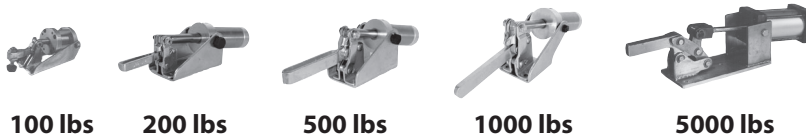

100 lbs

200 lbs

500 lbs

1000 lbs

5000 lbs

Swing Clamps Section 14

Hold-down clamp with a clamping arm that rotates 90° for clear loading. Sturdy helical-cam mechanism first rotates arm, then clamps down. Double acting.



14 lbs

25 lbs

66 lbs

100 lbs

165 lbs

277 lbs



Air Accessories p. 507

Complete selection of accessories including clamping valves, check valves, exhaust mufflers, and air fittings.

AIR-POWERED TOGGLE CLAMPS

INFO+: SEE PAGE 439 FOR MATERIAL SPECIFICATIONS

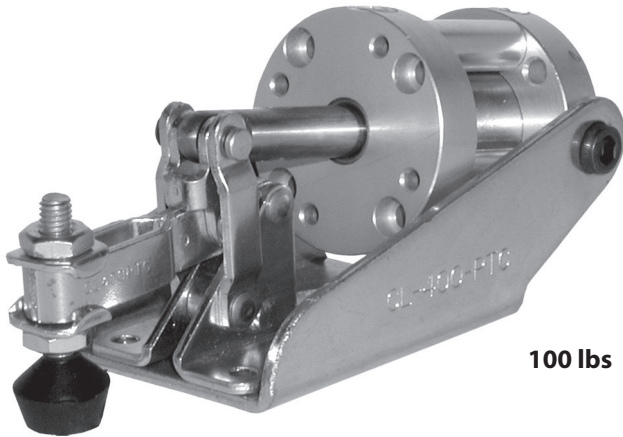

100 lbs

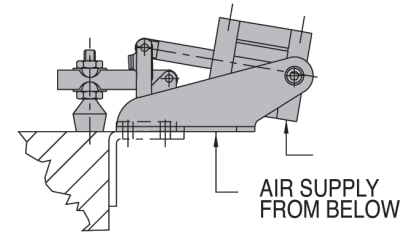
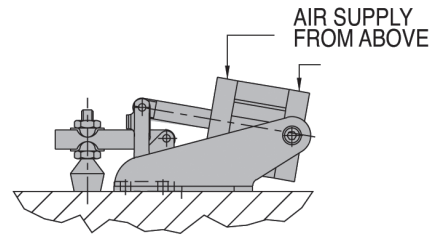

CL-400-PTC

Super-compact hold-down clamp for applications where space is at a premium. Open arm allows spindle adjustment. Toggle linkage provides high holding capacity and insures positive mechanical locking even if air pressure fails. Arm opens 100°. 3/4"-bore double-acting air cylinder with #10-32 ports. Supplied with #10-32 flat-cushion spindle CL-316112-FC and (2) CL-3166-TW flanged washers. 100-psi maximum input air pressure. Shipping weight 0.8 lbs. An optional bracket for side mounting is also available (CL-400-PCBR).

Holding capacity: 100 lbs

Clamping force at 100 psi, at center of arm: 100 lbs

Also available with position sensing...

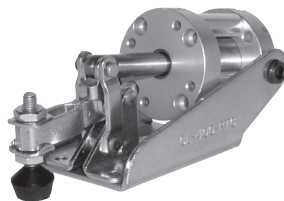

Please see our web catalog for more information.

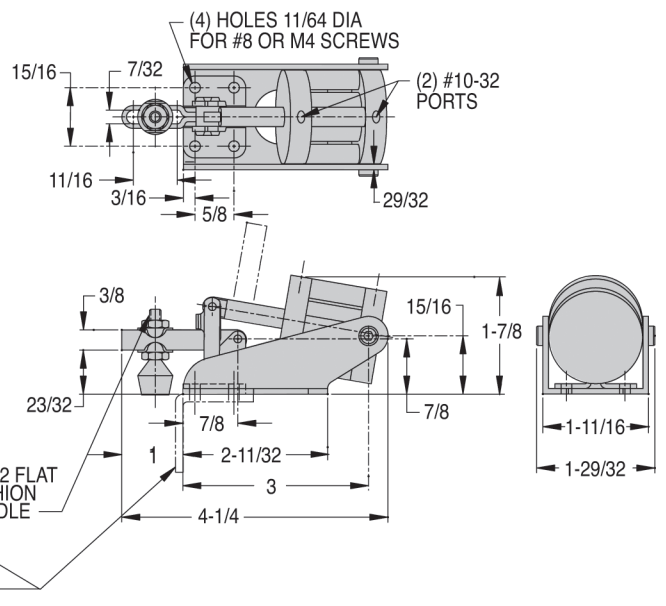

AIR-POWERED TOGGLE CLAMPS

INFO+: SEE PAGE 439 FOR MATERIAL SPECIFICATIONS

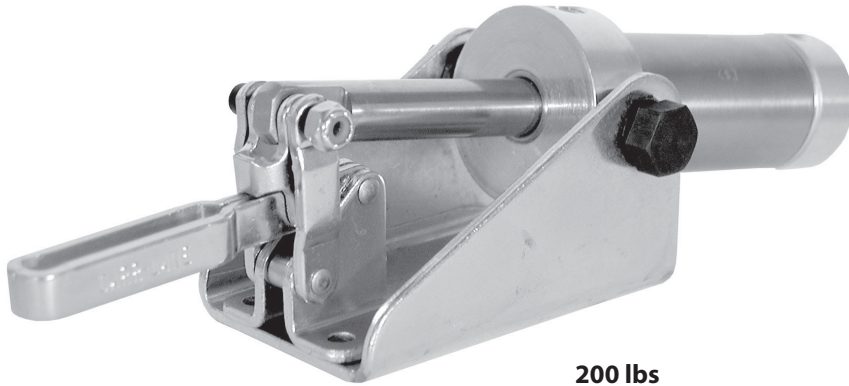

200 lbs

CL-500-PTC

Small-yet-powerful hold-down clamp with a long open arm. Toggle linkage provides high holding capacity and insures positive mechanical locking even if air pressure fails. Arm opens 100°. 1-1/4" bore double-acting air cylinder with 1/8-NPT ports. Accepts any 1/4-20 short spindle and (2) CL-148-TW flanged washers. 100-psi maximum input air pressure. Shipping weight 2.5 lbs.

Holding capacity: 200 lbs
Clamping force at 100 psi, at center of arm: 200 lbs

Also available with position sensing:

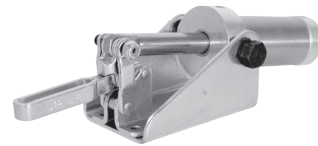

Please see our web catalog for more information.

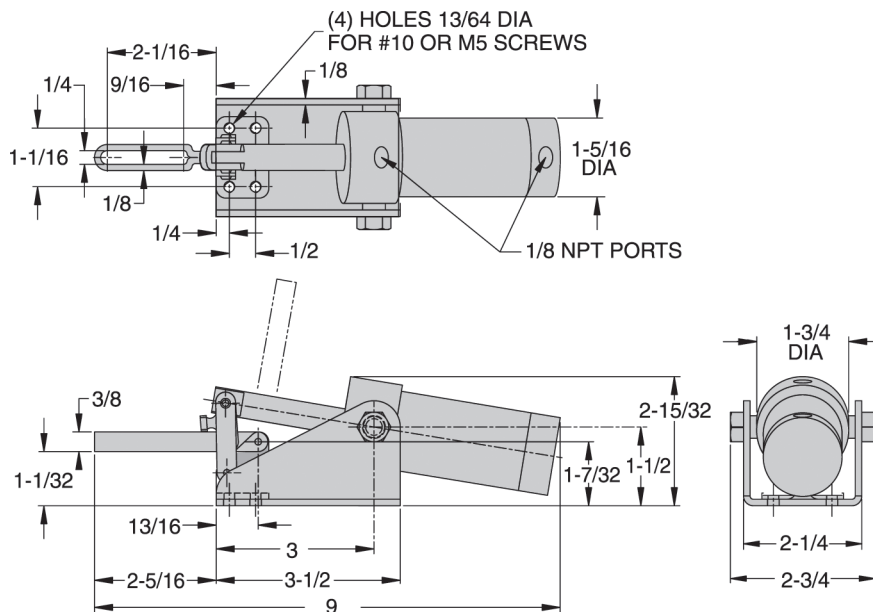

AIR-POWERED TOGGLE CLAMPS

INFO+: SEE PAGE 439 FOR MATERIAL SPECIFICATIONS

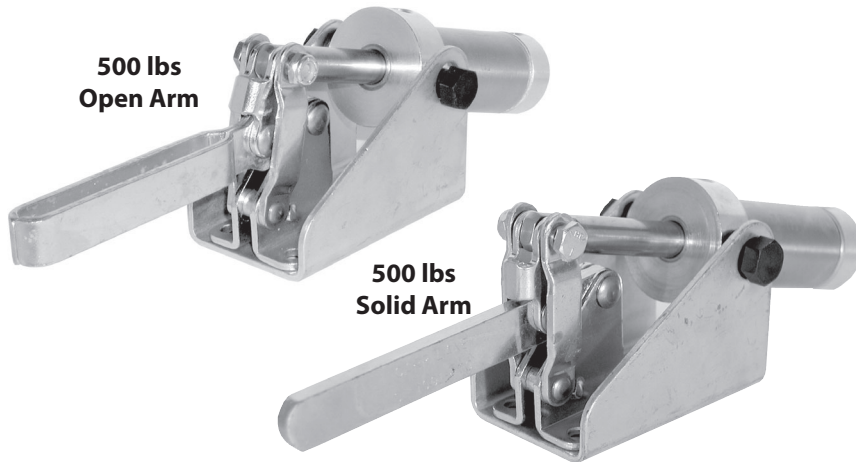

CL-1000-PTC CL-1001-PTC

Popular medium-size hold-down clamp available with a solid arm, or an open arm for spindle adjustment. Toggle linkage provides high holding capacity and insures positive mechanical locking even if air pressure fails. Arm opens 92°. 1-1/4"-bore double-acting air cylinder with 1/8"-NPT ports. Accepts any 5/16-18 short spindle and (2) CL-51610-TW flanged washers. Solid-arm version accepts a CL-518000-BR bolt retainer. 100-psi maximum input air pressure. Shipping weight 3.0 lbs.

Holding capacity: 500 lbs
Clamping force at 100 psi, at center of arm: 390 lbs

Also available with position sensing:



Please see our web catalog for more information.

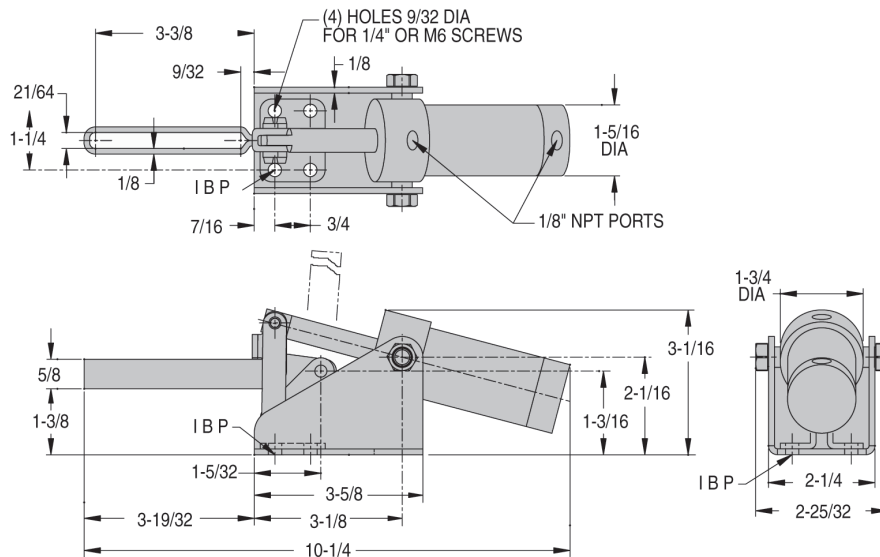

AIR-POWERED TOGGLE CLAMPS

INFO+: SEE PAGE 439 FOR MATERIAL SPECIFICATIONS

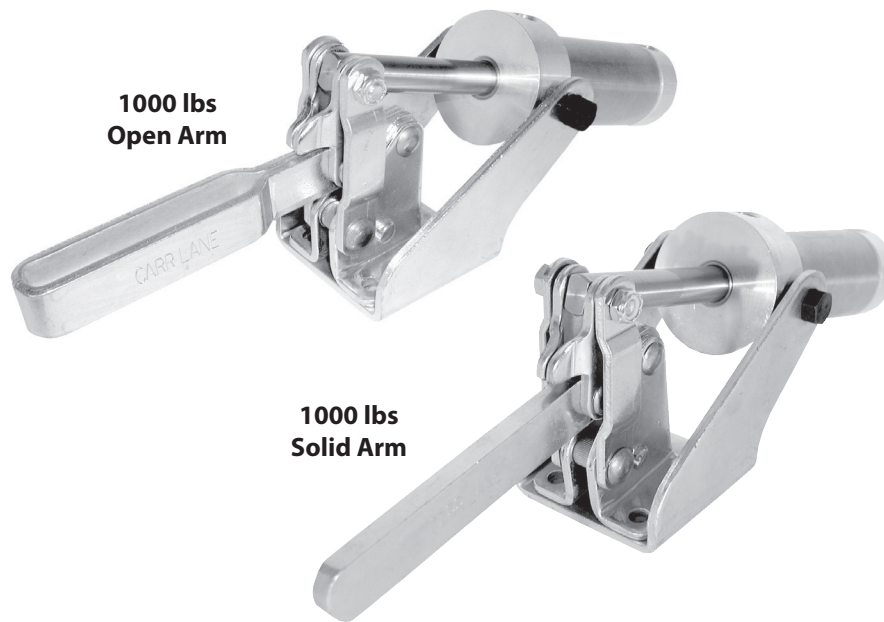

CL-2000-PTC CL-2001-PTC

Open Arm
Solid Arm

Extra-large hold-down clamp available with a solid arm, or an open arm for spindle adjustment. Toggle linkage provides high holding capacity and insures positive mechanical locking even if air pressure fails. Arm opens 83°. 1-3/4" bore double-acting air cylinder with 1/4-NPT ports. Accepts any 1/2-13 spindle and (2) CL-1213-TW flanged washers. Solid-arm version accepts a CL-113000-BR bolt retainer. 100 psi maximum input air pressure. Shipping weight 6.0 lbs.

Holding capacity: 1000 lbs
Clamping force at 100 psi, at center of arm 680 lbs

Also available with position sensing:



Please see our web catalog for more information.

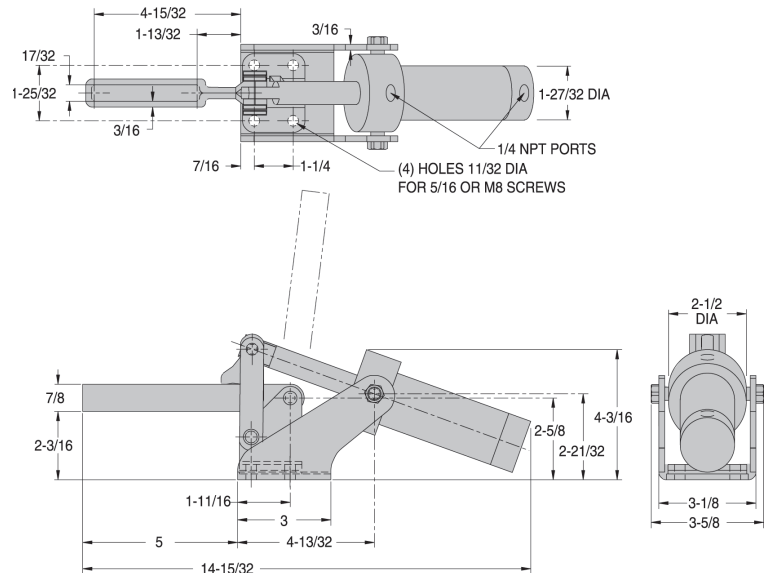

AIR-POWERED TOGGLE CLAMPS

INFO+: SEE PAGE 439 FOR MATERIAL SPECIFICATIONS

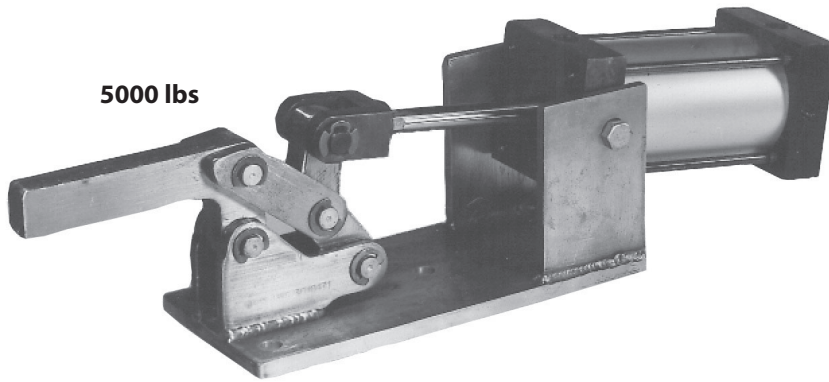

CL-3000-PTC

Heavy-duty hold-down clamp with a solid forged steel clamping arm. Toggle linkage provides high holding capacity and insures positive mechanical locking even if air pressure fails. Arm opens 83°. 2-1/2"-bore double-acting air cylinder with 1/4-NPT ports. 150-psi maximum input air pressure. Shipping weight 15.0 lbs.

Holding capacity: 5000 lbs
Clamping force at 100 psi, at center of arm: 1600 lbs

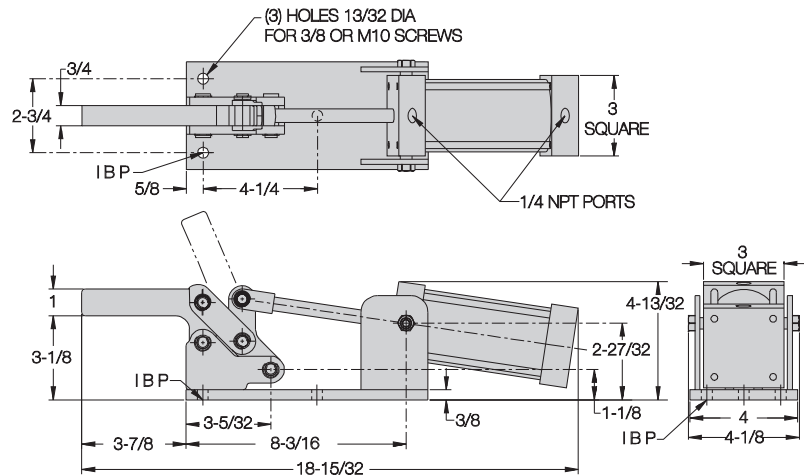

CLAMPING VALVES*

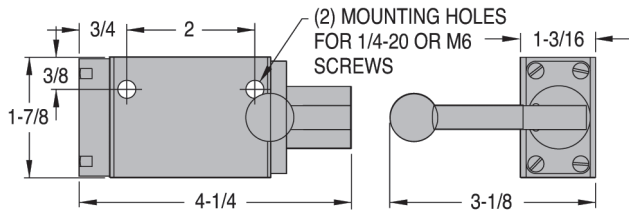

CL-14-PCAV

Versatile two-position, four-way valve for simple and convenient clamp control. Five 1/4-NPT ports. 150 psi maximum pressure.

CHECK VALVES*

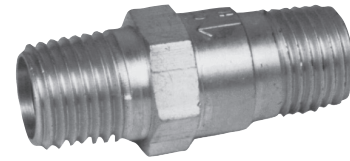

CLR-224-ACV

Allows air to flow in one direction only. 1/4-NPT male x 2.

EXHAUST MUFFLERS*

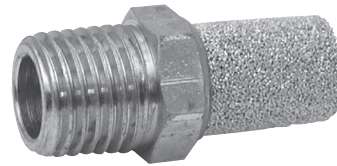

CL-14-PCEM

Durable, compact, sintered-bronze exhaust muffler. 1/4-NPT male.

AIR FITTINGS*

Quick-Disconnect Coupler



CL-14-PCQD
Both halves, 1/4-NPT female
CL-14-PCQDS
Female socket, 1/4-NPT female
CL-14-PCQDP
Male plug, 1/4-NPT female
(Industrial Interchange)

Adapter

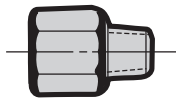

CL-1014-PCA
#10-32 female x 1/4-NPT male
CL-1418-PCA
1/4-NPT female x 1/8-NPT male
CL-3814-PCA
3/8-NPT female x 1/4-NPT male

Hex Nipple

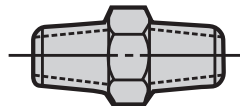

CL-10-PCHN
#10-32 male x 2
CL-14-PCHN
1/4-NPT male x 2
CL-38-PCHN
3/8-NPT male x 2
CL-3814-PCHN
3/8-NPT male x 1/4-NPT male

Coupling

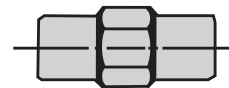

CL-10-PCCP
#10-32 female x 2
CL-14-PCCP
1/4-NPT female x 2

Tubing Connector

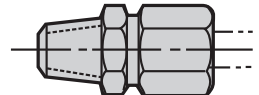

CL-1810-PCTC
1/8-OD tube x #10-32 male
CL-14-PCTC
1/4-OD tube x 1/4-NPT male
(Includes compression sleeve and nut)

Street Elbow

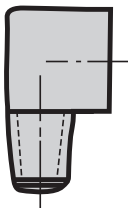

CL-14-PCSE
1/4-NPT
Female x 1/4-NPT male

Banjo Elbow

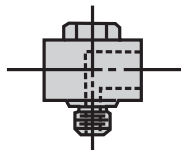

CL-10-PCBE
#10-32 female x #10-32 male

Tee

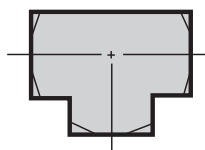

CL-10-PCTE
#10-32 female x 3
CL-14-PCTE
1/4-NPT female x 3

Branch Tee

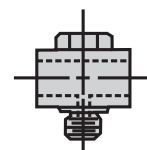

CL-10-PCBT
#10-32 female x 2,
#10-32 male

Cross

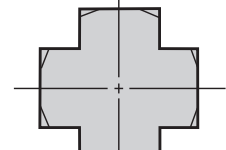

CL-14-PCCR
1/4-NPT female x 4

* Do not use in high-pressure hydraulic lines.

HEX-HEAD SPINDLES



Simple spindle design provides maximum clamping force. Fully threaded for maximum adjustment range. Assembly includes two jam nuts. Available in thread sizes from #8-32 to 5/8-11 (M4 to M16 in metric).

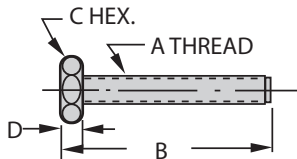

STEEL (INCH)

PART NO.	A	B	C	D
CL-316112-SA	#10-32	1-3/8	5/16	1/8
CL-14112-SA	1/4-20	1-11/16	7/16	3/16
CL-14200-SA		2-3/16		
CL-516212-SA	5/16-18	2-11/16	1/2	3/16
CL-38314-SA	3/8-16	3-1/4	9/16	1/4
CL-12314-SA	1/2-13	3-5/16	3/4	5/16
CL-58438-SA	5/8-11	4-3/8	15/16	3/8

VINYL-DIPPED STEEL (INCH)

CL-832208-FC	#8-32	1-3/16	1/4	1/8
CL-14100-SA	1/4-20	1	7/16	3/16
CL-14208-SA		1-1/2		

STAINLESS STEEL (INCH)

CL-83234-SA-S	#8-32	7/8	1/4	1/8
CL-832203-SA-S		1-1/8		
CL-316100-SA-S	#10-32	1-1/8	5/16	1/8
CL-14112-SA-S	1/4-20	1-11/16	7/16	3/16
CL-516200-SA-S	5/16-18	1-15/16	1/2	3/16
CL-516212-SA-S		2-11/16		
CL-38212-SA-S	3/8-16	2-1/2	9/16	1/4
CL-38314-SA-S		3-1/4		
CL-12234-SA-S	1/2-13	2-13/16	3/4	5/16

NYLON (INCH)

CL-832203-SA	#8-32	7/8	1/4	1/8
--------------	-------	-----	-----	-----

STEEL (METRIC)

PART NO.	A	B	C	D
CLM-530-SA	M5	1.32	8mm	.14
CLM-640-SA	M6	1.75	10mm	.18
CLM-650-SA		2.15		
CLM-850-SA	M8	2.19	13mm	.22
CLM-865-SA		2.78		
CLM-1070-SA	M10	3.03	17mm	.28
CLM-1275-SA	M12	3.27	19mm	.31
CLM-16100-SA	M16	4.33	24mm	.39

STAINLESS STEEL (METRIC)

CLM-416-SA-S	M4	.75	7mm	.12
CLM-425-SA-S		1.10		
CLM-530-SA-S	M5	1.32	8mm	.14
CLM-640-SA-S	M6	1.75	10mm	.18
CLM-650-SA-S		2.15		
CLM-850-SA-S	M8	2.19	13mm	.22
CLM-865-SA-S		2.78		
CLM-1070-SA-S	M10	3.03	17mm	.28

NYLON (METRIC)

CLM-416-SA	M4	.75	7mm	.12
------------	----	-----	-----	-----

FLAT-CUSHION SPINDLES



This is the standard spindle supplied with most clamps. Molded neoprene tip provides medium clamping force with some compensation for part-size variation. Also provides scratchfree clamping. Neoprene cushion has a durometer hardness of 70 shore A, and an operating temperature range of -40°F to 220°F. Spindle is fully threaded for maximum adjustment range. Assembly includes two jam nuts.

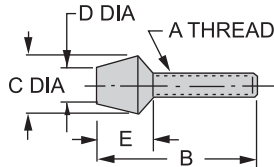

STEEL (INCH)

PART NO.	A	B	C DIA	D	E
CL-316112-FC	#10-32	1-3/8	9/16	7/16	7/16
CL-14112-FC	1/4-20	1-5/8	5/8	13/32	5/8
CL-14200-FC		2-1/8			
CL-518208-FC	5/16-18	2-1/4	3/4	1/2	3/4
CL-516212-FC		3			
CL-38212-FC	3/8-16	2-1/2	13/16	5/8	7/8
CL-38314-FC		3-1/2			

FLAT-CUSHION SPINDLES, QUICK ADJUSTING



Same as the Flat-Cushion Spindles above, except with two knurled nuts, instead of hex jam nuts, for convenient hand tightening. Use for quick spindle adjustment in applications where high-torque tightening with a wrench is not required.

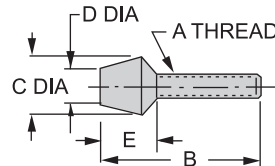

STEEL (INCH)

PART NO.	A	B	C DIA	D	E
CL-316112-FCQA	#10-32	1-3/8	9/16	7/16	7/16
CL-14112-FCQA	1/4-20	1-5/8	5/8	13/32	5/8
CL-14200-FCQA		2-1/8			
CL-518208-FCQA	5/16-18	2-1/4	3/4	1/2	3/4
CL-516212-FCQA		3			
CL-38212-FCQA	3/8-16	2-1/2	13/16	5/8	7/8
CL-38314-FCQA		3-1/2			

POLYURETHANE FLAT CUSHIONS



Polyurethane cushions are tougher and slightly harder than standard neoprene cushions. Ideal when greater clamping force is required while still providing scratchfree clamping and some compensation for part-size variation. Molded-in stainless steel insert provides superior thread strength. Ideal for making custom-length Flat Cushion Spindles by inserting a threaded stud. Polyurethane cushion has a hardness 85 Shore A, operating temperature range -90°F to 200°F.

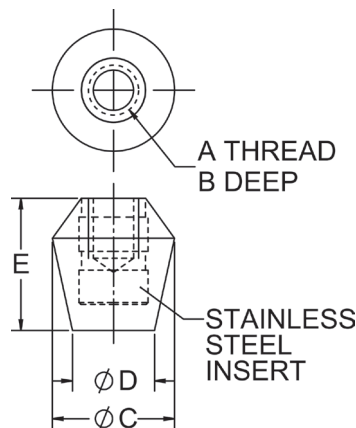

STAINLESS (INCH)

PART NO.	A	B	C DIA	D DIA	E
CL-1032-FCP	#10-32	.19	.56	.44	.53
CL-1420-FCP	1/4-20	.30	.63	.47	.63
CL-51618-FCP	5/16-18	.33	.75	.50	.75
CL-3816-FCP	3/8-16	.38	.81	.63	.88

STAINLESS (METRIC)

PART NO.	A	B	C DIA	D DIA	E
CLM-5-FCP	M5	.19	.56	.44	.53
CLM-6-FCP	M6	.24	.63	.47	.63
CLM-8-FCP	M8	.30	.75	.50	.75
CLM-10-FCP	M10	.35	.81	.63	.88

CONE-CUSHION SPINDLES



Excellent for clamping into drilled holes, slots, or corners. Molded neoprene tip provides medium clamping force with some compensation for part-size variation. Also provides scratchfree clamping. Neoprene cushion has a durometer hardness of 70 shore A, and an operating temperature range of -40°F to 220°F. Spindle is fully threaded for maximum adjustment range. Assembly includes two jam nuts.

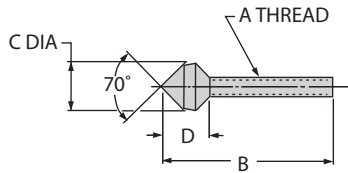

STEEL (INCH)

PART NO.	A	B	C DIA	D
CL-316112-CC	#10-32	1-3/8	9/16	7/16
CL-14112-CC	1/4-20	1-5/8	5/8	5/8
CL-14200-CC		2-1/8		5/8
CL-516212-CC	5/16-18	3	3/4	3/4
CL-38314-CC	3/8-16	3-1/2	13/16	7/8

SWIVEL-FOOT SPINDLES



Swivel foot provides full contact on uneven or sloped surfaces. Assembly includes two jam nuts.

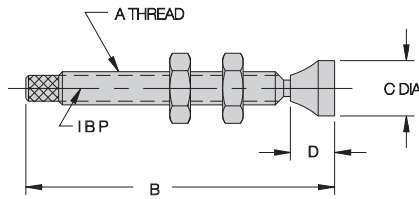

STEEL (INCH)

PART NO.	A	B	C DIA	D
CL-14112-SF	1/4-20	1-3/4	1/2	3/8
CL-14200-SF		2-1/4		
CL-516212-SF	5/16-18	2-3/4	9/16	7/16
CL-38314-SF	3/8-16	3-1/2	5/8	1/2

SWIVEL SCREW CLAMPS

11



Screw clamp with patented removable, interchangeable swivel foot, available in many sizes and varieties. Add "N" to part no. for Delrin® foot, e.g. CL-23-SSCN. **INFO+**: See page 121 for additional lengths and foot options. Order two jam nuts separately.

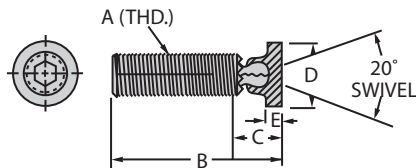

STEEL (INCH)

PART NO.	JAM NUT PART NO. (2 REQD)	A	B	C	D DIA	E
CL-23-SSC	CL-4-JN	1/4-20	1-19/32	23/64	3/8	1/8
CL-27-SSC	CL-5-JN	5/16-18	2-3/32	27/64	1/2	5/32
CL-43-SSC	CL-6-JN	3/8-16	3-1/8	1/2	9/16	3/16
CL-44-SSC	CL-8-JN	1/2-13	4-1/16	17/32	3/4	3/16
CL-46-SSC	CL-10-JN	5/8-11	5-3/64	21/32	15/16	7/32

STEEL (METRIC)

CLM-23-SSC	CLM-6-JN	M6	1.67	.36	3/8	1/8
CLM-27-SSC	CLM-8-JN	M8	2.06	.42	1/2	5/32
CLM-32-SSC	CLM-10-JN	M10	3.08	.62	9/16	3/16
CLM-36-SSC	CLM-12-JN	M12	4.00	.53	3/4	3/16
CLM-40-SSC	CLM-16-JN	M16	4.97	.66	15/16	7/32

STAINLESS STEEL (INCH)

CL-23-SSC-S	CL-4-JN-S	1/4-20	1-19/32	23/64	3/8	1/8
CL-27-SSC-S	CL-5-JN-S	5/16-18	2-3/32	27/64	1/2	5/32
CL-43-SSC-S	CL-6-JN-S	3/8-16	3-1/8	1/2	9/16	3/16

SPRING-LOADED SPINDLES



Clamps with strong spring force to compensate for varying part thicknesses. Excellent for clamping castings that vary slightly in size. To install, weld bolt retainer to clamping arm. Assembly includes two jam nuts, a die spring, and a bolt retainer.

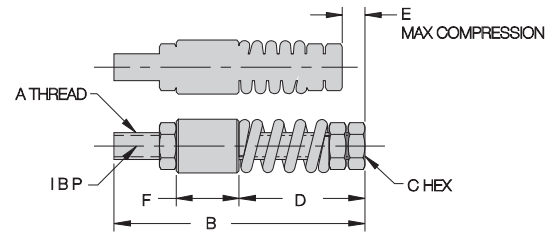

STEEL (INCH)

PART NO.	A	B	C	D		E	FORCE AT "E" (lbs)	F
				MIN	MAX			
CL-14200-SL	1/4-20	2-1/4	7/16	1-9/32	1-3/8	1/4	50	5/8
CL-516212-SL	5/16-18	2-3/4	1/2	1-11/16	1-7/8	1/4	100	5/8
CL-38314-SL	3/8-16	3-1/2	9/16	1-3/4	2-9/32	5/16	200	7/8

Our Customer Service team is here to help



Ordering
Information

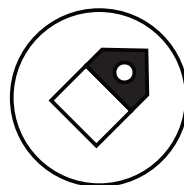

Price &
Availability



Request
A Quote



cs@carrlane.com
314.647.6200

FLANGED WASHERS



Two flanged washers required per clamp

For open-arm clamps. Use two flanged washers to mount spindle, one above the arm and one below.

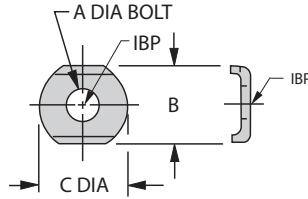

STEEL

PART NO.	A	B	C DIA
CL-832-TW	#8-32 or M4	7/16	15/32
CL-3166-TW	#10-32 or M5	1/2	9/16
CL-147-TW	1/4-20 or M6	9/16	5/8
CL-148-TW		19/32	11/16
CL-51610-TW	5/16-18 or M8	3/4	7/8
CL-3811-TW	3/8-16 or M10	15/16	1
CL-1213-TW	1/2-13 or M12	1-5/32	1-1/4
CL-5811-TW	5/8-11 or M16	1-3/8	1-15/32

STAINLESS STEEL

PART NO.	A	B	C DIA
CL-832-TW-S	#8-32 or M4	7/16	15/32
CL-3166-TW-S	#10-32 or M5	1/2	9/16
CL-147-TW-S	1/4-20 or M6	9/16	5/8
CL-148-TW-S		19/32	11/16
CL-51610-TW-S	5/16-18 or M8	3/4	7/8
CL-3811-TW-S	3/8-16 or M10	15/16	1

BOLT RETAINERS



BR
For VTC clamps



S
For TC clamps

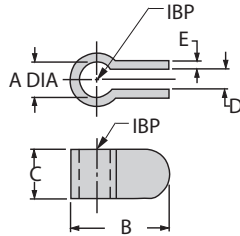

BR (FOR HTC & VTC CLAMPS)

PART NO.	SPINDLE SIZE	A DIA	B	C	D	E
CL-142000-BR	1/4-20 or M6	9/32	1-1/4	1/2	3/16	3/32
CL-518000-BR	5/16-18 or M8	21/64	1-1/4	5/8	1/4	3/32
CL-316000-BR	3/8-16 or M10	17/32	1-1/2	3/4	5/16	1/8
CL-113000-BR	1/2-13 or M12	9/16	1-5/8	7/8	3/8	1/8
CL-511000-BR	5/8-11 or M16	11/16	1-7/8	1-1/4	3/8	1/8

S (FOR TC CLAMPS)

PART NO.	SPINDLE SIZE	A DIA	B DIA	C
CL-1458-S	1/4-20 or M6	.257	5/8	5/8
CL-51658-S	5/16-18 or M8	.316	5/8	5/8
CL-3878-S	3/8-16 or M10	.397	3/4	7/8

For solid-arm clamps. Weld on bolt retainer at desired arm length and spindle angle.

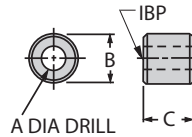

MOUNTING BRACKETS



Handy bracket for side-mounting small clamps. One reversible bracket fits several clamps.

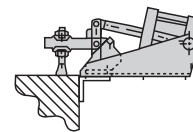
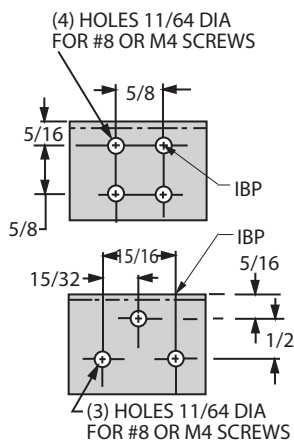

Downholding

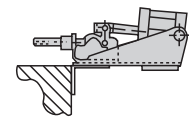

Push/Pull

PART NO.	FITS DOWNHOLDING CLAMPS	FITS PUSH CLAMPS
CL-400-PCBR	CL-150-VTC	CL-50-SPC
	CL-400-PTC	CL-600-PPC

STAGE AND FILM

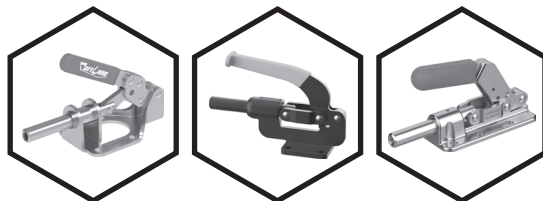

Stage & Film

Carr Lane tooling components including wagon brakes, lifting pins, hoist rings and more are trusted on stages across the globe.

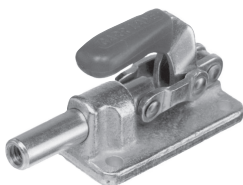

Push/Pull Toggle Clamps
p. 490-501



Lifting Pins
p. 58-59



Ball Lock Pins
p. 48-57



Glow Wagon Brakes
p. 514



Hoist Rings
p. 73-92



Threaded Inserts
p. 345-351



Hi-Viz Hammers
p. 338

GLOW WAGON BRAKES

CLAMP BODY: 1215, 1008, 1010, AND/OR 1018 STEEL, ZINC PLATED BLACK CHROMATE
 RIVETS: 400-SERIES STAINLESS
 HANDLE: GLOW-IN-THE-DARK VINYL



Medium-sized clamp locks in extended or retracted position.

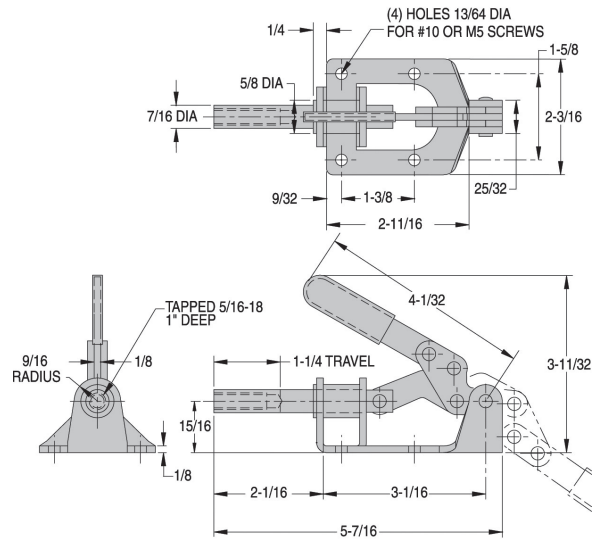

CL-150-SPC-BZ

Wagon Brakes with a black finish and glow-in-the-dark handles are specifically designed for use on stage-set designs, but can be used with other mobile jigs and carts. Wagon Brakes provide secure stabilization of your set designs, the ability to effortlessly re-arrange sets in an instant, and safety for your crew with special handles that glow in the dark for at least 8 hours. Glow-in-the-dark handles reduce the worry of trip hazards for stagehands as they work to set the scene.

Wagon Brakes literally lift your scenery off its movable casters, securing it in place and preventing any movement until you are ready to change the scene. A rugged toggle action provides the mechanical advantage to make lifting easy, and locks “over center” for safety. No drilling is ever required on your stage floor – just lock these Wagon Brakes in place to secure your stage set underneath the actors’ feet.

The medium-size plunger clamp shown here (CL-150-SPC-BZ) has a 1-1/4” plunger travel, is tapped to accept any 5/16-18 threaded foot and has a 300 lbs holding capacity. CL-250-SPC-BZ has a 1-5/8” plunger travel, is tapped to accept any 3/8-16 threaded foot and has an 800 pound holding capacity. Both lock in extended and retracted position. Made in USA.

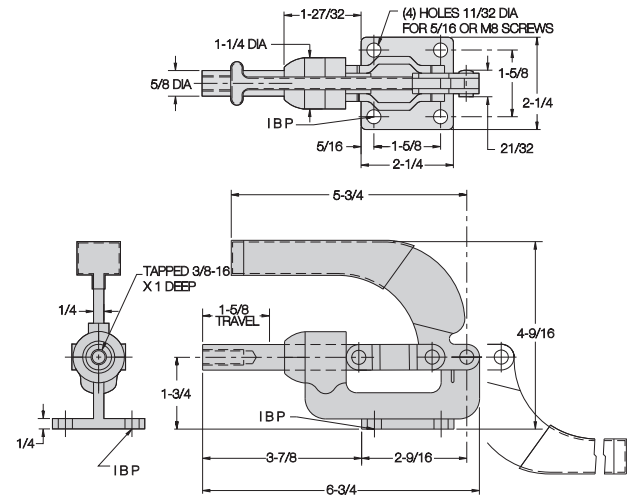

CL-250-SPC-BZ

PART NO.	DESCRIPTION	TAPPED HOLE IN PLUNGER	HOLDING CAPACITY	SHIPPING WEIGHT
CL-150-SPC-BZ	Tapped Plunger, Flanged Base	5/16-18	300 lbs.	.7 lbs.
CL-250-SPC-BZ	Tapped Plunger, Flanged Base	3/8-16	800 lbs.	1.9 lbs.

DRILL-JIG BUSHINGS

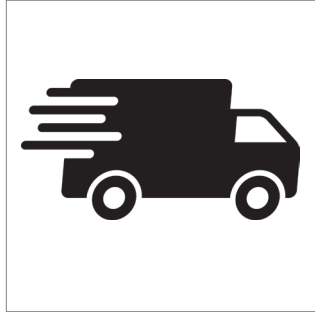

**Quick-Ship
Drill Bushings**



Press-Fit Bushings



Renewable Bushings



Liner Bushings



Bushing Handles



**Lockscrews &
Clamps**



Castable Bushings



**Chip-Breaker
Bushings**



**Directed-Coolant
Bushings**



Oil-Groove Bushings

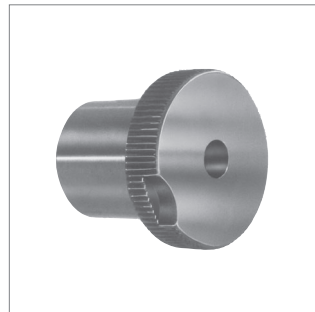

Gun-Drill Bushings



Template Bushings



**Threaded-Template
Bushings**



Air-Feed-Drill Bushings

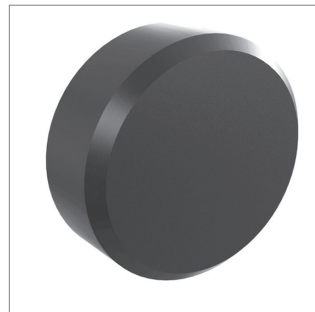

**See also:
Round Carbide Pads**

BUSHING SELECTION

INCH				METRIC			
P	- 20	- 8	- .1250	PM	- 8	- 12	- 4.50
Type	OD in 64ths of an inch	Length in 16ths of an inch	ID as 4-place decimal inch	Type	OD in mm	Length in mm	ID as 2-place decimal mm

PRESS FIT:

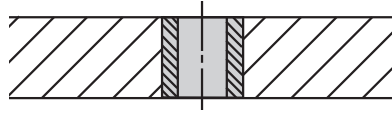

Types **P**, **PC** (carbide), and **PM** (metric). This is the most-popular and least-expensive drill bushing. P bushings are permanently pressed into the jig plate, usually flush with the top surface. They are generally used for single-step drilling or reaming operations when you do not expect to replace bushings during the tooling's lifetime. P bushings can be mounted closer together than headed bushings, but offer less resistance to heavy axial loads.

HEAD PRESS FIT:

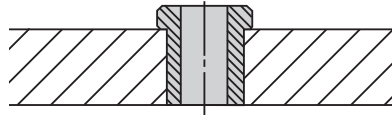

Types **H**, **HC** (carbide), and **HM** (metric). Similar to a P bushing, but with a head to resist heavy axial loads. H bushings are permanently pressed into the jig plate. They are generally used for single-step drilling or reaming operations when you do not expect to replace bushings during the tooling's lifetime. The head can be left exposed, or recessed by counterboring the installation hole. Note: The "length" listed for an inch head-press-fit bushing refers to its length under the head, while the metric version's "length" is its overall length.

SERRATED PRESS FIT:

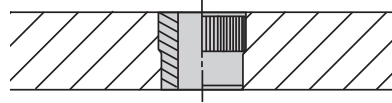

Types **SP** and **SPM** (metric). Similar to a P bushing, but with top serrations to prevent rotation in soft materials. Recommended in high-torque situations for materials such as magnesium, aluminum, masonite, or wood. Finish-ground OD ensures accurate ID location. Serrations also resist axial force to prevent pushing the bushing through the jig plate.

SLIP/FIXED RENEWABLE:

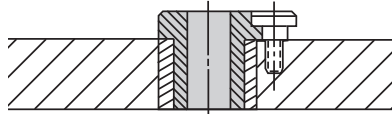

Types **SF**, **SFC** (carbide), and **SFM** (metric). Replaceable bushing generally used with a liner bushing and lockscrew. Use when you expect to replace bushings during the tooling's lifetime, or when you want to switch bushings to perform multi-step operations with the same tooling. SF bushings combine the benefits of older S-type slip-renewable and F-type fixed-renewable bushings: One side has a small recess for fixed mounting; the other has a locking recess that allows the bushing to slip down, then lock in place by rotating it. S and F types are now obsolete and combination SF bushings will be furnished at no extra charge.

FLAT MILLED RENEWABLE:

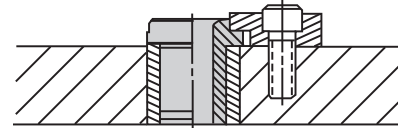

Types **FM** and **FMC** (carbide). Replaceable bushing used for extra resistance to rotational forces under harsh conditions. This bushing, generally used with a liner, has a milled locking flat to allow fastening securely with a flat clamp. FM bushings also have a standard recess on the other side to allow using a lockscrew instead.

LINER:

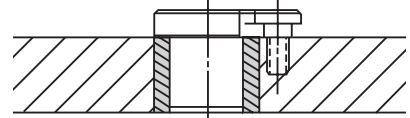

Types **L** and **PM** (metric). Liners are permanent bushings used to hold renewable drill bushings. The liner's ID has a precise sliding fit with the renewable bushing's OD. The hardened liner accurately locates the renewable bushing and protects the jig plate from wear caused by frequent bushing replacement. Note: Metric liner bushings are the same as metric press-fit bushings.

HEAD LINER:

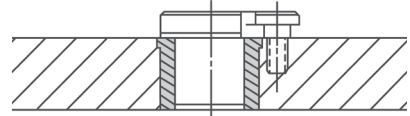

Types **HL** and **HM** (metric). Similar to an L bushing, but with a head to resist heavy axial loads. Head liners are permanent bushings used to hold renewable drill bushings. The head liner's ID has a precise sliding fit with the renewable bushing's OD. The hardened head liner accurately locates the renewable bushing and protects the jig plate from wear caused by frequent bushing replacement. Note: The "length" listed for a head liner refers to its overall length, not its length under the head. Metric head-liner bushings are the same as metric head-press-fit bushings.

UN-A-LOK™ LINER:

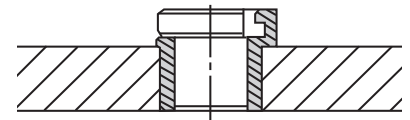

Types **UL** and **ULM** (metric). Similar to an HL head liner, but incorporating a special locking tab that eliminates the need for a lockscrew. Un-A-Lok liners are permanent bushings used to hold SF renewable drill bushings (on the "slip" side only, not the "fixed" side). Although slightly more expensive than a head liner plus a lock screw, installation time is dramatically reduced.

CHIP BREAKER:

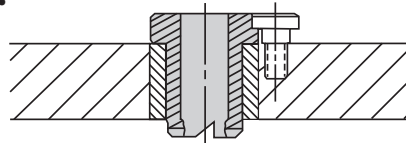

Types **CH** and **CHM** (metric). Similar to an SF renewable bushing, but with specially designed chip-breaking notches on the drill-exit end. Use to break up chips from tough, stringy materials, to reduce friction and heat buildup. Reduces bushing wear at the drill-exit end and reduces the chance of tool or workpiece damage. A chip-breaker bushing should extend beyond its liner to allow chips to escape. Chip breakers are also available on other bushing types such as P, H, and DC.

BUSHING SELECTION

DIRECTED COOLANT:

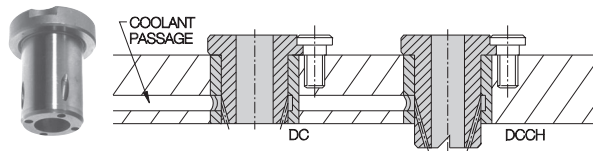

Types **DC**, **DCCH** (chip breaker), **DCL** (liner), and **DCHL** (head liner). Similar to an SF renewable bushing, but with passages to direct coolant to the cutting area. This design is particularly good for washing away chips, especially when ordered as the combination Directed Coolant Chip Breaker (DCCH). DC bushings require special liners, DCL or DCHL, to direct coolant from a drilled manifold passage to the holes in the bushing's OD wall.

OIL GROOVE:

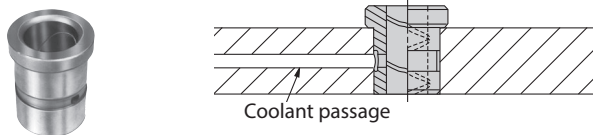

Oil grooves are available on most drill-bushing types, including P, H, and SF. Use when you need complete drill lubrication and cooling, such as when drilling hardened steel. Oil grooves are specially designed coolant passageways in the bushing's ID wall. Choose from 25 different groove styles. End wipers are also available, to keep out dirt and chips.

DIAMOND GROOVE:

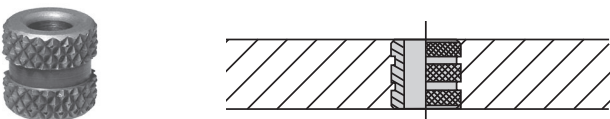

Types **DG** and **DGM** (metric). A bushing for cast-in-place or potted installation. Diamond-knurled OD provides superior holding strength against both rotational and axial forces. Since the bushing's OD is not ground, keep the ID accurately located during casting or potting to ensure accuracy in the finished tool.

SERRATA GROOVE:

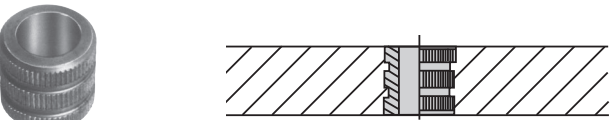

Type **SG**. Can be cast in place or potted, just as a diamond-groove bushing, or can also be pressed into an installation hole. Straight knurl provides less resistance to axial loads than the diamond knurl on a DG bushing. Since the bushing's OD is not ground, keep the ID accurately located during casting or potting to ensure accuracy in the finished tool.

DIAMOND-KNURL UN-A-LOK™ LINER:

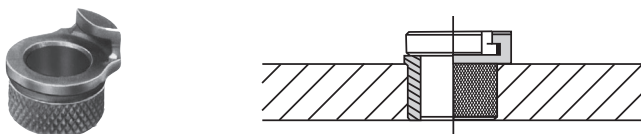

Types **ULD** and **ULDM** (metric). A liner for cast-in-place or potted installation, used to hold SF renewable drill bushings. Un-A-Lok™ liners incorporate a special locking tab that eliminates the need for a lockscrew. Holds only the "slip" side of an SF bushing, not the "fixed" side. Diamond-knurled OD provides superior holding strength against both rotational and axial forces. Since the bushing's OD is not ground, keep the ID accurately located during casting or potting to ensure accuracy in the finished tool.

EZ CAST LINER:

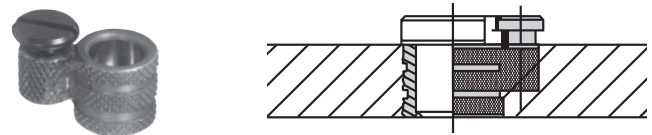

Type **EZ**. Another liner for cast-in-place or potted installation, used to hold SF renewable drill bushings. Unlike diamond-knurl unlock liners, EZ-cast liners hold either the "slip" or "fixed" side of an SF bushing, since they include an integral lockscrew holder. Diamond-knurled OD provides superior holding strength against both rotational and axial forces. Since the bushing's OD is not ground, keep the ID accurately located during casting or potting to ensure accuracy in the finished tool.

GUN DRILL:

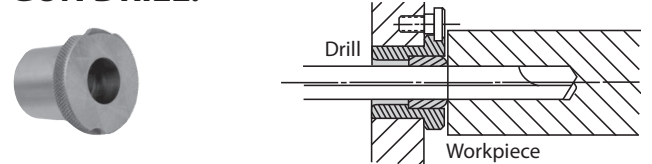

Types **GD**, **GDL** (liner), and **GDI** (insert). Drill bushings for gun-drilling machines, such as Eldorado, Drillmation, DeHoff, and Lahr. Gun drill bushings are similar to SF renewable bushings, but with the drill bearing at the bushing's head end. Depending on the gun-drilling machine, bushings are either one-piece or two-piece (a liner and an insert).

TEMPLATE:

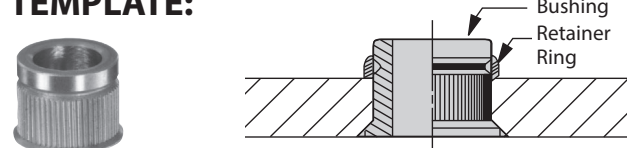

Type **TB**. An economical bushing designed for thin template jig plates from 1/16- to 3/8-inch thick. Bushings are held in place by a retainer ring. The OD serrations prevent the bushing from spinning. Bushings can be removed and reused by breaking the aluminum retainer ring (extra retainer rings available).

CIRCUIT BOARD:

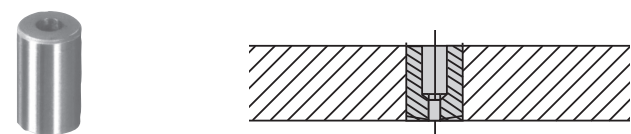

Types **CB** and **CBC** (carbide). Headless and head-type bushings made especially for circuit-board drilling machines. Available for Electro-Mechano, Excellon, Waco, Digital, Nationwide, Edlund, Tektronix, Leland-Gifford, Palomar, Hughes, Rapidrill, and Reliable drilling machines.

AIR-FEED DRILL:

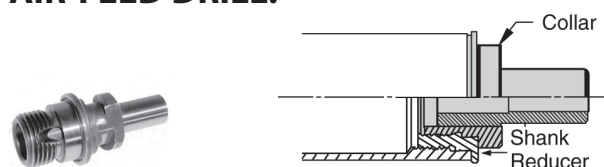

Type **A**. Drill-bushing shanks, collars, adaptors, and locking accessories for air-feed drills, tappers, and back-spotfacers. Available for all standard drill motors, including Gardner-Denver, Keller, Aro, Buckeye, Quackenbush, Desoutter, and Ingersoll-Rand.

INSTALLATION AND TECHNICAL DATA

RECOMMENDED CHIP CLEARANCE:

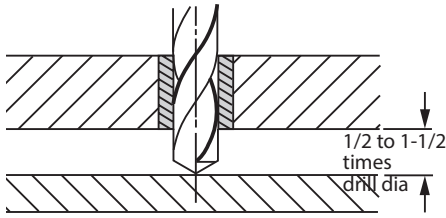

To minimize drill bending and maximize hole accuracy, mount drill bushings as close to the workpiece as possible while still allowing adequate chip clearance. The necessary clearance depends on workpiece material and chip stringiness. For example, cast iron, with fine chips requires about 1/2 times drill diameter for chip clearance. Materials that produce long, stringy chips, such as cold-rolled steel and aluminum, require at least one-drill-diameter clearance. To reduce clearance even with long, stringy chips, exit-end chip breakers are available.

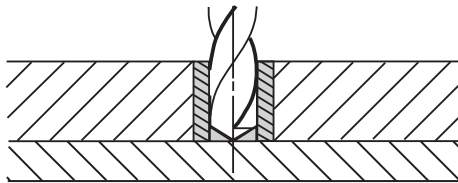

Direct workpiece contact is usually not recommended. Chips can escape only up through the drill's flutes, drill-bearing length is shortened by the drill point's length, and drill-withdrawal burrs can raise the jig plate. Direct contact may be necessary, though, for maximum bearing length when drilling sloped surfaces (see below). Also, reamer bushings can be mounted much closer than drill bushings, due to much finer chips, for more-accurate hole finishing.

SPECIAL BUSHINGS FOR SLOPED WORKPIECE SURFACES:

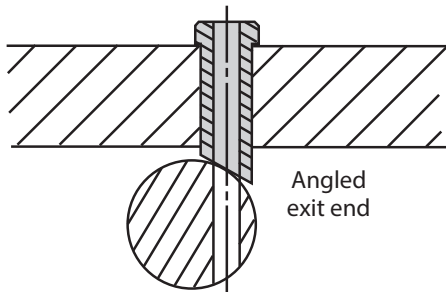

Whenever the drilling axis is not perpendicular to the workpiece surface, locate the exit end as close to the part as possible. Otherwise the drill will tend to wander. For maximum drill guiding, we recommend specifying bushings with an angle milled on the exit end, tangent to the workpiece surface at point of entry.

SPECIAL BUSHINGS FOR CLOSE HOLE SPACING:

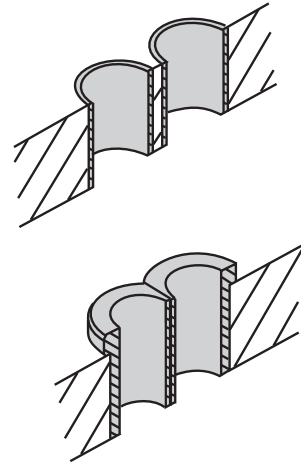

When holes are located close together, special bushings are sometimes required. Thinwall bushings, where the bushing ID is larger than the normal ID range for a given OD, are often a good solution. Holes for thinwall bushings must be very accurate and round, because these bushings are more easily distorted. For very-close hole spacing, especially with headed bushings, specify bushings with ground flats.

INSTALLATION-HOLE PREPARATION FOR PRESS-FIT BUSHINGS:

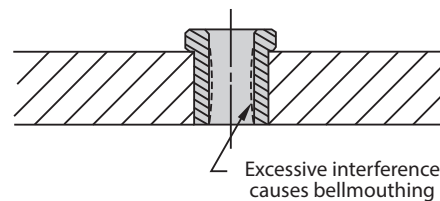

To avoid jig-plate or bushing distortion, do not use excessive interference fits on press-fit bushings. See tables on opposite page for recommended hole sizes in unhardened steel or cast iron jig plates. Always prepare installation holes using a jig borer or reamer. Standard chucking reamers (with a plus tolerance) usually produce installation holes to the tolerances shown in the table. Other factors to consider are: (1) headed bushings require less interference to resist drilling thrust; (2) longer bushings in thick plates require less interference; (3) bushings with thinner walls are more prone to distortion; (4) less-ductile jig-plate materials require less interference.

INSTALLATION AND TECHNICAL DATA

INSTALLATION PROCEDURE:

INCH

PRESS-FIT BUSHING OD		RECOMMENDED HOLE SIZE
NOMINAL	ACTUAL	
5/32	.1578-.1575	.1565-.1570
3/16	.1891-.1888	.1880-.1883
13/64	.2046-.2043	.2037-.2040
1/4	.2516-.2513	.2507-.2510
5/16	.3141-.3138	.3132-.3135
3/8	.3766-.3763	.3757-.3760
13/32	.4078-.4075	.4069-.4072
7/16	.4392-.4389	.4382-.4385
1/2	.5017-.5014	.5007-.5010
9/16	.5642-.5639	.5632-.5635
5/8	.6267-.6264	.6257-.6260
3/4	.7518-.7515	.7507-.7510
7/8	.8768-.8765	.8757-.8760
1	1.0018-1.0015	1.0007-1.0010
1-1/8	1.1270-1.1267	1.1257-1.1260
1-1/4	1.2520-1.2517	1.2507-1.2510
1-3/8	1.3772-1.3768	1.3757-1.3760
1-1/2	1.5021-1.5018	1.5007-1.5010
1-3/4	1.7523-1.7519	1.7507-1.7510
2-1/4	2.2525-2.2521	2.2507-2.2510
2-3/4	2.7526-2.7522	2.7507-2.7510

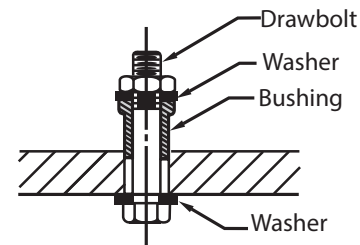
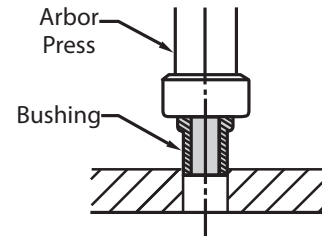

METRIC

PRESS-FIT BUSHING OD		RECOMMENDED HOLE SIZE (H7)
NOMINAL	ACTUAL (s6)	
3mm	3.020-3.014mm	3.000-3.010mm
4mm	4.027-4.019mm	4.000-4.012mm
5mm	5.027-5.019mm	5.000-5.012mm
6mm	6.027-6.019mm	6.000-6.012mm
7mm	7.032-7.023mm	7.000-7.015mm
8mm	8.032-8.023mm	8.000-8.015mm
10mm	10.032-10.023mm	10.000-10.015mm
12mm	12.039-12.028mm	12.000-12.018mm
15mm	15.039-15.028mm	15.000-15.018mm
18mm	18.039-18.028mm	18.000-18.018mm
22mm	22.048-22.035mm	22.000-22.021mm
26mm	26.048-26.035mm	26.000-26.021mm
30mm	30.048-30.035mm	30.000-30.021mm
35mm	35.059-35.043mm	35.000-35.025mm
42mm	42.059-42.043mm	42.000-42.025mm
48mm	48.059-48.043mm	48.000-48.025mm
55mm	55.072-55.053mm	55.000-55.030mm
62mm	62.072-62.053mm	62.000-62.030mm
70mm	70.078-70.059mm	70.000-70.030mm
78mm	78.078-78.059mm	78.000-78.030mm
85mm	85.093-85.071mm	85.000-85.035mm
95mm	95.093-95.071mm	95.000-95.035mm
105mm	105.101-105.079mm	105.000-105.035mm
115mm	115.101-115.079mm	115.000-115.035mm
125mm	125.117-125.092mm	125.000-125.040mm

We recommend installing bushings with an arbor press whenever possible. If the bushing's OD is large enough, you can also use a drawbolt with two washers as shown above. If a hammer is the only tool available, do not strike the bushing directly or it could fracture. Use a soft-metal punch to cushion the blows. Before installing a press-fit bushing, lubricate the inside of the mounting hole and outside of the bushing with a lubricant such as lithium grease. Otherwise the bushing may score the mounting hole, and may be difficult to replace later.

GROUND LEAD FOR EASY INSTALLATION:

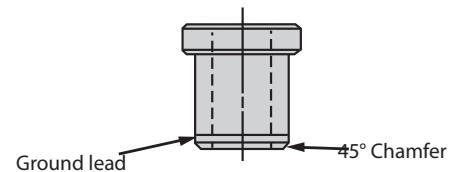

All bushings feature a concentric ground lead and a 45° chamfer on the exit end to ensure perfect alignment during installation.

INSTALLATION AND TECHNICAL DATA

DRILL ENTRANCE RADIUS:

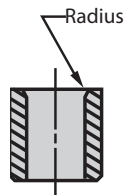

Bushings feature a blended and polished radius at the drill-entrance end for smooth drill entry and proper alignment, preventing drill wear and breakage. Radius size varies in proportion to drill size.

COUNTERBORES ON LONG BUSHINGS:

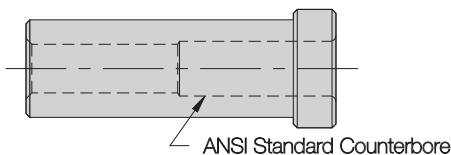

Long bushings with small IDs are slightly counterbored for proper drill-bearing length and chip clearance, as specified by ANSI standards. Counterbores prevent binding and heat buildup due to excessive bearing length. **INFO+:** See chart on page 521 for ANSI counterbore depths. Counterbore diameters are generally 1/32 inch larger than the inside diameter, and are angled at the bottom for smooth entrance. No-counterbore bushings are available on request as specials.

UNGROUND BUSHINGS AVAILABLE FOR OVERSIZE HOLES:

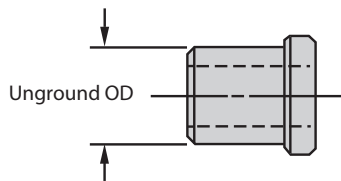

We offer bushings with unfinished ODs for custom-fitting to oversize holes. They are slightly larger than nominal diameter to provide grinding stock, .005-.020 extra, depending on the OD size (see charts under each specific bushing type). We recommend grinding on a mandrel to hold ID/OD concentricity.

CONCENTRICITY:

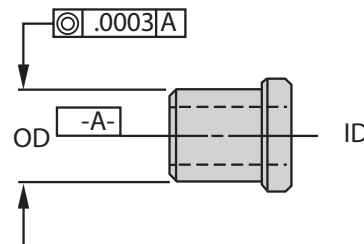

Bushing OD is ground concentric to the ID to within .0003 TIR for ID sizes from 1/8 inch to 1/2 inch (3mm to 12mm), unless otherwise indicated. For larger or smaller sizes, concentricity is within .0005 TIR. Unground bushings are concentric to within .006 TIR. On counterbored bushings, concentricity applies only over the drill-bearing length.

OTHER TOLERANCES:

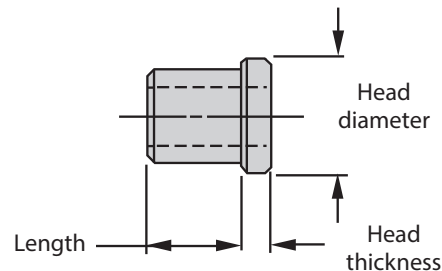

Any dimensions where tolerances are not specifically listed are held to +/- .015 inches on standard ANSI sizes. Special tolerances for any dimension are available on request as specials.

MATERIAL:

Standard drill-bushing material is 1144 or 52100 steel, heat treated to achieve RC 62-64 ID hardness, and other high-carbon steels. Optional materials such as tungsten carbide (Grade C2 carbide with steel head), 52100 steel, A2 tool steel, D2 tool steel, M2 tool steel, 416 stainless, 440C stainless, 17-4PH stainless, 303 stainless, 660 bronze, Ampco 18 bronze, Ampco 21 bronze, Oilite, and brass are available as specials.

COUNTERBORE DATA



TYPE P DRILL BEARING LENGTH

DRILL SIZE (ID)	OD	BUSHING LENGTH													
		1/4	5/16	3/8	1/2	3/4	1	1-3/8	1-1/2	1-3/4	2-1/8	2-1/2	3		
.0135 - .0291	5/32	FULL	FULL	FULL	5/16	5/16	5/16	5/16	5/16	5/16	5/16	5/16	5/16		
.0292 - .0519															
.0520 - .0625															
.0135 - .0291	3/16	FULL	FULL	FULL	5/16	5/16	5/16	5/16	5/16	5/16	5/16	5/16	5/16		
.0292 - .0519															
.0520 - .0634					FULL	7/16	7/16	7/16	7/16	7/16	7/16	7/16	7/16	7/16	7/16
.0635 - .0995															
.0135 - .0291	13/64	FULL	FULL	FULL	5/16	5/16	5/16	5/16	5/16	5/16	5/16	5/16	5/16		
.0292 - .0519															
.0520 - .0634					FULL	7/16	7/16	7/16	7/16	7/16	7/16	7/16	7/16	7/16	7/16
.0635 - .0995															
.0980 - .1406	1/4	FULL	FULL	FULL	FULL	7/16	5/8	5/8	5/8	5/8	5/8	5/8	5/8		
.1250 - .1935	5/16	FULL	FULL	FULL	FULL	FULL	5/8	5/8	5/8	5/8	5/8	5/8	5/8		
.1935 - .2880	3/8	FULL	FULL	FULL	FULL	FULL	5/8	5/8	5/8	5/8	5/8	5/8	5/8		
.1875 - .2570	13/32	FULL	FULL	FULL	FULL	FULL	5/8	5/8	5/8	5/8	5/8	5/8	5/8		
.2340 - .2900	7/16	FULL	FULL	FULL	FULL	FULL	5/8	5/8	5/8	5/8	5/8	5/8	5/8		
.1875 - .3160	1/2	FULL	FULL	FULL	FULL	FULL	5/8	3/4	3/4	3/4	3/4	3/4	3/4		
.3125 - .4375	5/8	FULL	FULL	FULL	FULL	FULL	FULL	FULL	FULL	FULL	FULL	FULL	1-1/2		
.3125 - .5313	3/4	FULL	FULL	FULL	FULL	FULL	FULL	FULL	FULL	FULL	FULL	FULL	1-1/2		



TYPE H DRILL BEARING LENGTH

RANGE (ID)	OD	BUSHING LENGTH (UNDER HEAD)												
		1/4	5/16	3/8	1/2	3/4	1	1-3/8	1-1/2	1-3/4	2-1/8	2-1/2	3	
.0135 - .0291	5/32	FULL	FULL	5/16	5/16	5/16	5/16	5/16	5/16	5/16	5/16	5/16	5/16	
.0292 - .0519				FULL										
.0520 - .0625														
.0135 - .0291	13/64	FULL	FULL	5/16	5/16	5/16	5/16	5/16	5/16	5/16	5/16	5/16	5/16	
.0292 - .0519														
.0520 - .0634				FULL	7/16	7/16	7/16	7/16	7/16	7/16	7/16	7/16	7/16	7/16
.0635 - .0995														
.0980 - .1406	1/4	FULL	FULL	FULL	7/16	7/16	5/8	5/8	5/8	5/8	5/8	5/8	5/8	
.1250 - .1935	5/16	FULL	FULL	FULL	FULL	FULL	5/8	5/8	5/8	5/8	5/8	5/8	5/8	
.1935 - .2280	3/8	FULL	FULL	FULL	FULL	FULL	5/8	5/8	5/8	5/8	5/8	5/8	5/8	
.1875 - .2570	13/32	FULL	FULL	FULL	FULL	FULL	5/8	5/8	5/8	5/8	5/8	5/8	5/8	
.2340 - .2900	7/16	FULL	FULL	FULL	FULL	FULL	5/8	5/8	5/8	5/8	5/8	5/8	5/8	
.1875 - .3160	1/2	FULL	FULL	FULL	FULL	FULL	3/4	3/4	3/4	3/4	3/4	3/4	3/4	
.3125 - .4375	5/8	FULL	FULL	FULL	FULL	FULL	FULL	FULL	FULL	FULL	FULL	FULL	1-1/2	
.3125 - .5313	3/4	FULL	FULL	FULL	FULL	FULL	FULL	FULL	FULL	FULL	FULL	FULL	1-1/2	



TYPE SF & FM DRILL BEARING LENGTH

DRILL SIZE (ID)	OD	BUSHING LENGTH (UNDER HEAD)																						
		1/4	5/16	3/8	1/2	3/4	1	1-3/8	1-1/2	1-3/4	2-1/8	2-1/2	3											
.0135 - .0291	3/16	1/4	5/16	5/16	5/16	5/16	5/16	5/16	5/16	5/16	5/16	5/16	5/16											
.0292 - .0519																								
.0520 - .0634																								
.0635 - .0980																								
.0995 - .1405	1/4	FULL	FULL	3/8	7/16	7/16	7/16	7/16	7/16	7/16	7/16	7/16												
.0135 - .0291	5/16	1/4	FULL	5/16	5/16	5/16	5/16	5/16	5/16	5/16	5/16	5/16	5/16											
.0292 - .0519																								
.0520 - .0634																								
.0635 - .0934																								
.0935 - .1249																								
.1250 - .1935		FULL												3/8	7/16	7/16	7/16	7/16	7/16	7/16	7/16	7/16	7/16	7/16
.1935 - .2280																								
.2340 - .2900	7/16	FULL	FULL	FULL	FULL	FULL	5/8	5/8	5/8	5/8	5/8	5/8	5/8											
.1405 - .1889	1/2	FULL	FULL	FULL	FULL	FULL	5/7	5/8	5/8	5/8	5/8	5/8	5/8											
.1890 - .3438							7/8	1	1	1	1	1	1	1	1	1								
.2950 - .5625																								

QUICK SHIP DRILL BUSHINGS



Quick-Ship Drill Bushings are popular bushing sizes that we do our best to keep in stock and ready for same-day shipment 100% of the time. These bushings include most common ID drill sizes.

PRESS-FIT BUSHINGS (P)

PART NO.	ID	OD	LENGTH
P-13-4-.0980	#40 (.0980)	13/64	1/4
P-13-8-.0980			1/2
P-16-4-.0980	#40 (.0980)	1/4	1/4
P-16-6-.0980			3/8
P-16-8-.0980			1/2
P-16-16-.0980			1
P-16-8-.0995	#39 (.0995)	1/4	1/2
P-16-8-.1065	#36 (.1065)	1/4	1/2
P-16-8-.1094	7/64 (.1094)	1/4	1/2
P-16-8-.1110	#34 (.1110)	1/4	1/2
P-16-8-.1130	#33 (.1130)	1/4	1/2
P-16-8-.1200	#31 (.1200)	1/4	1/2
P-16-4-.1250	1/8 (.1250)	1/4	1/4
P-16-8-.1250			1/2
P-20-4-.1250	1/8 (.1250)	5/16	1/4
P-20-6-.1250			3/8
P-20-8-.1250			1/2
P-20-12-.1250			3/4
P-16-4-.1285	#30 (.1285)	1/4	1/4
P-16-8-.1285			1/2
P-20-4-.1285	#30 (.1285)	5/16	1/4
P-20-8-.1285			1/2
P-16-8-.1360	#29 (.1360)	1/4	1/2
P-16-8-.1405	#28 (.1405)	1/4	1/2
P-16-8-.1406	9/64 (.1406)	1/4	1/2
P-20-4-.1406	9/64 (.1406)	5/16	1/4
P-20-8-.1406			1/2
P-20-12-.1406			3/4
P-20-8-.1440	#27 (.1440)	5/16	1/2
P-20-6-.1470	#26 (.1470)	5/16	3/8
P-20-8-.1470			1/2
P-20-6-.1495	#25 (.1495)	5/16	3/8
P-20-8-.1495			1/2
P-20-10-.1495			5/8
P-20-6-.1520	#24 (.1520)	5/16	3/8
P-20-6-.1562	5/32 (.1562)	5/16	3/8
P-20-12-.1562			1/2
P-20-4-.1570	#22 (.1570)	5/16	1/4
P-20-6-.1590	#21 (.1590)	5/16	3/8
P-20-8-.1590			1/2
P-20-12-.1590			3/4
P-20-6-.1610	#20 (.1610)	5/16	3/8
P-20-8-.1610			1/2
P-20-5-.1660	#19 (.1660)	5/16	5/16
P-20-8-.1660			1/2
P-20-6-.1719	11/64 (.1719)	5/16	3/8
P-20-8-.1719			1/2
P-20-12-.1719			3/4
P-20-6-.1730			3/8
P-20-8-.1730	#17 (.1730)	5/16	1/2
P-20-8-.1770	#16 (.1779)	5/16	1/2

PART NO.	ID	OD	LENGTH
P-20-6-.1800	#15 (.1800)	5/16	3/8
P-20-8-.1800			1/2
P-26-6-.1865	.1865	13/32	3/8
P-20-4-.1875	3/16 (.1875)	5/16	1/4
P-20-5-.1875			5/16
P-20-6-.1875			3/8
P-20-8-.1875			1/2
P-20-10-.1875			5/8
P-20-12-.1875			3/4
P-20-16-.1875			1
P-26-4-.1875			1/4
P-26-8-.1875			1/2
P-26-12-.1875	3/4		
P-26-16-.1875	1		
P-32-6-.1875	3/16 (.1875)	1/2	3/8
P-32-8-.1875			1/2
P-32-12-.1875			3/4
P-32-16-.1875			1
P-20-4-.1890	#12 (.1890)	5/16	1/4
P-20-6-.1890			3/8
P-20-8-.1890			1/2
P-20-4-.1910	#11 (.1910)	5/16	1/4
P-20-6-.1910			3/8
P-20-8-.1910			1/2
P-20-12-.1910			3/4
P-20-16-.1910			1
P-26-4-.1910	#11 (.1910)	13/32	1/4
P-26-6-.1910			3/8
P-26-8-.1910			1/2
P-32-8-.1910	#11 (.1910)	1/2	1/2
P-20-5-.1935	#10 (.1935)	5/16	5/16
P-20-8-.1935			1/2
P-26-8-.1935	#10 (.1935)	13/32	1/2
P-32-6-.1935	#10 (.1935)	1/2	3/8
P-32-8-.1935			1/2
P-26-8-.1960	#9 (.1960)	13/32	1/2
P-32-6-.1960	#9 (.1960)	1/2	3/8
P-32-8-.1960			1/2
P-32-12-.1960			3/4
P-24-8-.2010	#7 (.2010)	3/8	1/2
P-26-8-.2010	#7 (.2010)	13/32	1/2
P-32-6-.2010	#7 (.2010)	1/2	3/8
P-32-8-.2010			1/2
P-32-12-.2010			3/4
P-32-6-.2031	13/64 (.2031)	1/2	3/8
P-32-8-.2031			1/2
P-32-12-.2031			3/4
P-32-6-.2130	#3 (.2130)	1/2	3/8
P-32-8-.2130			1/2
P-32-16-.2130			1
P-26-6-.2188	7/32 (.2188)	13/32	3/8
P-26-8-.2188			1/2
P-32-6-.2188	7/32 (.2188)	1/2	3/8
P-32-8-.2188			1/2
P-32-12-.2188			3/4
P-32-16-.2188			1
P-26-16-.2210	#2 (.2210)	13/32	1
P-32-6-.2210	#2 (.2210)	1/2	3/8
P-32-8-.2210			1/2
P-32-12-.2210			3/4
P-32-6-.2280	#1 (.2280)	1/2	1/2
P-32-12-.2280			3/4
P-28-6-.2344			3/8
P-28-8-.2344	15/64 (.2344)	7/16	1/2
P-28-12-.2344			3/4
P-32-6-.2380	B (.2380)	1/2	3/8

PART NO.	ID	OD	LENGTH
P-26-6-.2490	.2490	13/32	3/8
P-20-6-.2500	1/4 (.2500)	5/16	3/8
P-24-8-.2500	1/4 (.2500)	3/8	1/2
P-26-4-.2500	1/4 (.2500)	13/32	1/4
P-26-5-.2500			5/16
P-26-6-.2500			3/8
P-26-8-.2500			1/2
P-26-12-.2500			3/4
P-26-16-.2500			1
P-28-4-.2500	1/4 (.2500)	7/16	1/4
P-28-5-.2500			5/16
P-28-6-.2500			3/8
P-28-8-.2500			1/2
P-28-10-.2500			5/8
P-28-12-.2500			3/4
P-28-16-.2500			1
P-32-4-.2500	1/4 (.2500)	1/2	1/4
P-32-6-.2500			3/8
P-32-8-.2500			1/2
P-32-12-.2500			3/4
P-32-16-.2500			1
P-26-8-.2510	.2510	13/32	1/2
P-26-12-.2510			3/4
P-28-8-.2510	.2510	7/16	1/2
P-32-8-.2520	6.40mm (.2520)	1/2	1/2
P-26-4-.2570	F (.2570)	13/32	1/4
P-26-5-.2570			5/16
P-26-8-.2570			1/2
P-28-16-.2570	F (.2570)	7/16	1
P-32-6-.2570	F (.2570)	1/2	3/8
P-32-8-.2570			1/2
P-32-12-.2570			3/4
P-32-8-.2610	G (.2610)	1/2	1/2
P-28-8-.2656	17/64 (.2656)	7/16	1/2
P-32-6-.2656	17/64 (.2656)	1/2	3/8
P-32-8-.2656			1/2
P-32-12-.2656			3/4
P-32-16-.2656			1
P-28-5-.2660	H (.2660)	7/16	5/16
P-32-16-.2660	H (.2660)	1/2	1
P-32-8-.2720	I (.2720)	1/2	1/2
P-32-8-.2770	J (.2770)	1/2	1/2
P-32-12-.2770			3/4
P-28-4-.2812	9/32 (.2812)	7/16	1/4
P-28-8-.2812			1/2
P-28-12-.2812			3/4
P-32-6-.2812	9/32 (.2812)	1/2	3/8
P-32-8-.2812			1/2
P-32-12-.2812			3/4
P-32-16-.2812			1
P-32-12-.2969			19/64 (.2969)
P-32-8-.3020	N (.3020)	1/2	1/2
P-32-12-.3020			3/4
P-32-6-.3115	.3115	1/2	3/8
P-32-6-.3125	5/16 (.3125)	1/2	3/8
P-32-8-.3125			1/2
P-32-12-.3125			3/4
P-32-16-.3125			1
P-40-8-.3125	5/16 (.3125)	5/8	1/2
P-40-16-.3125			1
P-40-22-.3125			1-3/8
P-32-6-.3160	O (.3160)	1/2	3/8
P-32-8-.3160			1/2
P-32-12-.3160			3/4
P-32-16-.3160			1
P-40-8-.3281	21/64 (.3281)	5/8	1/2

QUICK SHIP DRILL BUSHINGS

PRESS-FIT BUSHINGS (P), continued

PART NO.	ID	OD	LENGTH		
P-40-8-.3438	11/32 (.3438)	5/8	1/2		
P-40-8-.3740	9.50mm (.3740)	5/8	1/2		
P-32-6-.3750	3/8 (.3750)	1/2	3/8		
P-32-8-.3750			1/2		
P-40-6-.3750	3/8 (.3750)	5/8	3/8		
P-40-8-.3750			1/2		
P-40-12-.3750			3/4		
P-40-16-.3750			1		
P-48-8-.3750			1/2		
P-48-10-.3750	3/8 (.3750)	3/4	5/8		
P-48-12-.3750			3/4		
P-48-16-.3750			1		
P-48-22-.3750			1-3/8		
P-40-8-.3770			V (.3770)	5/8	1/2
P-40-12-.3770					3/4
P-40-8-.3906	25/64 (.3906)	5/8	1/2		
P-40-16-.3906			1		
P-40-8-.4062	13/32 (.4062)	5/8	1/2		
P-40-16-.4062			1		
P-40-8-.4219	27/64 (.4219)	5/8	1/2		
P-48-16-.4219	27/64 (.4219)	3/4	1		
P-40-8-.4375	7/16 (.4375)	5/8	1/2		
P-40-12-.4375			3/4		
P-40-16-.4375			1		
P-48-8-.4375			1/2		
P-48-12-.4375			3/4		
P-48-16-.4375			1		
P-48-22-.4375	1-3/8				
P-48-8-.4531	29/64 (.4531)	3/4	1/2		
P-48-12-.4531			3/4		
P-48-8-.4688	15/32 (.4688)	3/4	1/2		
P-48-8-.4844	31/64 (.4844)	3/4	1/2		
P-48-12-.4990	.4990	3/4	3/4		
P-40-8-.5000	1/2 (.5000)	5/8	1/2		
P-40-12-.5000			3/4		
P-40-16-.5000			1		
P-48-8-.5000			1/2		
P-48-10-.5000	1/2 (.5000)	3/4	5/8		
P-48-12-.5000			3/4		
P-48-16-.5000			1		
P-48-20-.5000			1-1/4		
P-48-22-.5000			1-3/8		
P-48-24-.5000			1-1/2		
P-56-10-.5000			5/8		
P-56-12-.5000			7/8		
P-56-16-.5000	1/2 (.5000)	1	1/2		
P-64-12-.5000	1/2 (.5000)	1	3/4		
P-64-16-.5000			1		
P-48-8-.5010	.5010	3/4	1/2		
P-48-10-.5156	33/64 (.5156)	3/4	5/8		
P-48-5-.5312	17/32 (.5312)	3/4	5/16		
P-48-12-.5312			3/4		
P-48-22-.5312			1-3/8		
P-56-8-.5625			1/2		
P-56-10-.5625	9/16 (.5625)	7/8	5/8		
P-56-12-.5625			3/4		
P-56-16-.5938			7/8		
P-48-24-.6250	5/8 (.6250)	3/4	1-1/2		
P-56-8-.6250	5/8 (.6250)	7/8	1/2		
P-56-10-.6250			5/8		
P-56-12-.6250			3/4		
P-56-16-.6250			1		
P-56-20-.6250			1-1/4		
P-56-22-.6250			1-3/8		
P-56-24-.6250			1-1/2		

PART NO.	ID	OD	LENGTH
P-64-8-.6250	5/8 (.6250)	1	1/2
P-64-12-.6250			3/4
P-64-16-.6250			1
P-64-22-.6250			1-3/8
P-56-8-.6406	41/64 (.6406)	7/8	1/2
P-64-8-.6562	21/32 (.6562)	1	1/2
P-64-12-.6562			3/4
P-64-16-.6562			1
P-64-20-.6719	43/64 (.6719)	1	1-1/4
P-64-8-.6875	11/16 (.6875)	1	1/2
P-64-16-.6875			1
P-64-20-.6875			1-1/4
P-64-8-.7500			1/2
P-64-12-.7500			3/4
P-64-16-.7500			1
P-64-20-.7500	1-1/4		
P-64-22-.7500	1-3/8		
P-64-24-.7500	1-1/2		

LINER BUSHINGS (L)

PART NO.	ID	OD	LENGTH
L-28-8	1/4	7/16	1/2
L-32-4	5/16	1/2	1/4
L-32-8			1/2
L-32-16			1
L-40-6-24	3/8	5/8	3/8
L-40-8-24			1/2
L-48-8	1/2	3/4	1/2
L-48-12			3/4
L-64-8	3/4	1	1/2
L-64-12			3/4
L-64-16			1
L-64-24			1-1/2
L-88-12	1	1-3/8	3/4
L-88-16			1
L-88-22			1-3/8

PRESS-FIT BUSHINGS METRIC (PM)

PART NO.	ID	OD	LENGTH
PM-6-8-3.00	3.00mm	6mm	8mm
PM-8-12-5.00	5.00mm	8mm	12mm
PM-10-10-6.00	6.00mm	10mm	10mm
PM-12-10-6.80	6.80mm	12mm	10mm
PM-12-10-8.00	8.00mm	12mm	10mm
PM-12-16-8.00			16mm
PM-15-12-8.40	8.40mm	15mm	12mm
PM-15-12-10.00	10.00mm	15mm	12mm
PM-18-12-12.00	12.00mm	18mm	12mm
PM-22-16-15.00	15.00mm	22mm	16mm
PM-30-20-20.00	20.00mm	30mm	20mm
PM-42-25-30.00	30.00mm	42mm	25mm

HEAD LINER BUSHINGS (HL)

PART NO.	ID	OD	LENGTH	F DIA	G
HL-48-12	1/2	3/4	3/4	7/8	3/32
HL-64-12	3/4	1	3/4	1-1	1/8

UN-A-LOK® LINER BUSHINGS (UL)

PART NO.	ID	OD	LENGTH	E	F DIA	G
UL-32-8	5/16	1/2	1/2	3/8	9/16	3/32
UL-48-8	1/2	3/4	1/2	1/2	13/16	3/32

HEAD PRESS-FIT BUSHINGS (H)

PART NO.	ID	OD	LENGTH UNDER HEAD	HEAD DIA	HEAD HEIGHT
H-16-8-.0980	#40 (.0980)	1/4	1/2	23/64	3/32
H-16-6-.1285	#30 (.1285)	1/4	3/8	23/64	3/32
H-16-8-.1285			1/2		
H-24-4-.2210	#2 (.2210)	3/8	1/4	1/2	3/32
H-26-6-.2500	1/4 (.2500)	13/32	3/8	1/2	5/32
H-32-8-.3125	5/16 (.3125)	1/2	1/2	39/64	7/32
H-40-8-.3750	3/8 (.3750)	5/8	1/2	51/64	7/32
H-48-4-.5000	1/2 (.5000)	3/4	1/4	59/64	7/32
H-48-6-.5000			3/8		
H-48-8-.5000			1/2		
H-56-8-.6250	5/8 (.6250)	7/8	1/2	1-7/64	1/4
H-56-16-.6250			1		
H-64-8-.7500	3/4 (.7500)	1	1/2	1-15/64	5/16

HEAD PRESS-FIT BUSHINGS METRIC (HM)

PART NO.	ID	OD	OVERALL LENGTH	HEAD DIA	HEAD HEIGHT
HM-12-16-8.00	8.00mm	12mm	16mm	15mm	3mm
HM-15-12-10.00	10.00mm	15mm	12mm	18mm	3mm
HM-18-20-12.00	12.00mm	18mm	20mm	22mm	4mm
HM-22-16-15.00	15.00mm	22mm	16mm	26mm	4mm
HM-30-20-20.00	20.00mm	30mm	20mm	34mm	5mm
HM-30-20-22.00	22.00mm	30mm	20mm	34mm	5mm
HM-55-30-42.00	42.00mm	55mm	30mm	59mm	5mm

PRESS FIT BUSHINGS

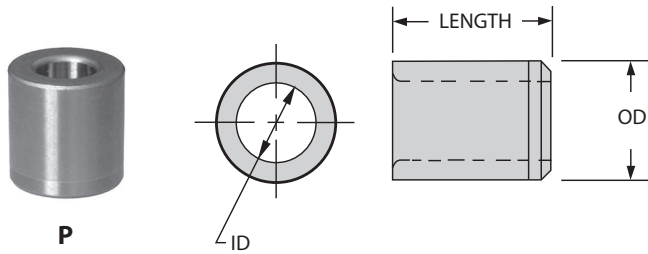

APPLICATIONS:

This is the most-popular and least-expensive drill bushing. P bushings are permanently pressed into the jig plate, usually flush with the top surface. They are generally used for single-step drilling or reaming operations when you do not expect to replace bushings during the tooling's lifetime. P bushings can be mounted closer together than headed bushings, but offer less resistance to heavy axial loads.

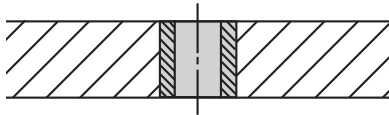

ORDERING EXAMPLES:

P-20-16-.1250	Standard inch bushing, inch ID
P-20-16-.1772	Standard inch bushing, mm ID (.1772 = 4.50mm)
P-20-16U-.1250	Unground OD
P-20-16-.1250 REAMER	Reamer tolerance on ID
P-20-16-.1250 NCB	No counterbore on long bushings marked with * (no counterbore is standard on all other bushings)
PC-20-16-.1250	Carbide bushing
PM-8-12-4.50	Standard metric bushing

Standard prices apply only to bushings with a standard-drill-size ID within the stated ID range. See catalog back cover for standard drill sizes and their decimal equivalents. For prices on non-standard ID sizes, including reamer-tolerance and tap-guide bushings, please contact factory.

STANDARD ID TOLERANCES:

From #80 to 1/4" + .0001/+0.0004	From .35 to 3mm +.002/+0.008mm
Over 1/4 to 3/4" + .0001/+0.0005	Over 3 to 6mm +.004/+0.012mm
Over 3/4 to 1-1/2" + .0002/+0.0006	Over 6 to 10mm +.005/+0.014mm
Over 1-1/2 to 2-3/4" + .0003/+0.0007	Over 10 to 18mm +.006/+0.017mm
	Over 18 to 30mm +.007/+0.020mm
	Over 30 to 50mm +.009/+0.025mm
	Over 50 to 80mm +.010/+0.029mm
	Over 80 to 120mm +.012/+0.034mm (G6 tolerance)

REAMER ID TOLERANCES:

From #60 to 1/4" + .0005/+0.0008	From 1 to 3mm +.006/+0.012mm
Over 1/4 to 1" + .0006/+0.0010	Over 3 to 6mm +.010/+0.018mm
Over 1" to 1-1/2" + .0008/+0.0012	Over 6 to 10mm +.013/+0.022mm
	Over 10 to 18mm +.016/+0.027mm
	Over 18 to 30mm +.020/+0.033mm (F6 tolerance)

ID RANGE	OD	LENGTH	ANSI PART NO.
.0135-.0291 #80-#70 .35-.70mm	5/32 .1578-.1575 (.166-.161 UNG)	1/4	P-10-4
		5/16	P-10-5
		3/8	P-10-6
		*1/2	P-10-8
.0292-.0519 #69-3/64 .75-1.25mm		1/4	P-10-4
		5/16	P-10-5
		3/8	P-10-6
		*1/2	P-10-8
.0520-.0625 #55-1/16 1.30-1.60mm		*3/4	P-10-12
		1/4	P-10-4
		5/16	P-10-5
		3/8	P-10-6
.0520-.0634 #55-1/16 1.30-1.60mm	*1/2	P-10-8	
	*3/4	P-10-12	
	1/4	P-12-4	
	5/16	P-12-5	
.0635-.0995 #52-#39 1.65-2.50mm	3/8	P-12-6	
	*1/2	P-12-8	
	*5/8	P-12-10	
	*3/4	P-12-12	
.0135-.0291 #80-#70 .35-.70mm	1/4	P-12-4	
	5/16	P-12-5	
	3/8	P-12-6	
	*1/2	P-12-8	
.0292-.0519 #69-3/64 .75-1.30mm	5/8	P-12-10	
	*3/4	P-12-12	
	1/4	P-13-4	
	5/16	P-13-5	
.0520-.0634 #55-1/16 1.35mm-1.60mm	3/8	P-13-6	
	*1/2	P-13-8	
	*3/4	P-13-12	
	*1	P-13-16	
.0635-.0995 #52-#39 1.65-2.50mm	1/4	P-13-4	
	5/16	P-13-5	
	3/8	P-13-6	
	1/2	P-13-8	
.0135-.0291 #80-#70 .35-.70mm	*3/4	P-13-12	
	*1	P-13-16	
	*1-3/8	P-13-22	
	1/4	P-13-4	
.0292-.0519 #69-3/64 .75-1.30mm	5/16	P-13-5	
	3/8	P-13-6	
	*1/2	P-13-8	
	*3/4	P-13-12	
.0520-.0634 #55-1/16 1.35mm-1.60mm	*1	P-13-16	
	1/4	P-13-4	
	5/16	P-13-5	
	3/8	P-13-6	
.0635-.0995 #52-#39 1.65-2.50mm	1/2	P-13-8	
	*3/4	P-13-12	
	*1	P-13-16	
	*1-3/8	P-13-22	

* **INFO+:** Counterbored, leaving correct drill-bearing length and clearance (see page 537 for bearing length).

CONTINUED ON NEXT PAGE

PRESS FIT BUSHINGS

ID RANGE	OD	LENGTH	ANSI PART NO.
.0980-.1406 #40-9/64 2.50-3.50mm	1/4 .2516-.2513 (.265-.260 UNG)	1/4	P-16-4
		5/16	P-16-5
		3/8	P-16-6
		1/2	P-16-8
		5/8	P-16-10
		*3/4	P-16-12
		*1	P-16-16
		*1-3/8	P-16-22
		*1-1/2	P-16-24
		*1-3/4	P-16-28
.1250-.1935 1/8-#10 3.20-4.90mm	5/16 .3141-.3138 (.327-.322 UNG)	1/4	P-20-4
		5/16	P-20-5
		3/8	P-20-6
		1/2	P-20-8
		5/8	P-20-10
		3/4	P-20-12
		*1	P-20-16
		*1-3/8	P-20-22
		*1-1/2	P-20-24
		*1-3/4	P-20-28
.1935-.2280 #10-#1 4.90-5.80mm	3/8 .3766-.3763 (.390-.385 UNG)	1/4	P-24-4
		5/16	P-24-5
		3/8	P-24-6
		1/2	P-24-8
		5/8	P-24-10
		3/4	P-24-12
		*1	P-24-16
.1875-.2570 3/16-F 4.75-6.50mm	13/32 .4078-.4075 (.421-.416 UNG)	1/4	P-26-4
		5/16	P-26-5
		3/8	P-26-6
		1/2	P-26-8
		3/4	P-26-12
		*1	P-26-16
		*1-3/8	P-26-22
		*1-1/2	P-26-24
		*1-3/4	P-26-28
.2340-.2900 A-L 5.90-7.40mm	7/16 .4392-.4389 (.453-.448 UNG)	1/4	P-28-4
		5/16	P-28-5
		3/8	P-28-6
		1/2	P-28-8
		5/8	P-28-10
		3/4	P-28-12
		*1	P-28-16
.1875-.3160 3/16-O 4.75-8.00mm	1/2 .5017-.5014 (.520-.515 UNG)	1/4	P-32-4
		5/16	P-32-5
		3/8	P-32-6
		1/2	P-32-8
		3/4	P-32-12
		*1	P-32-16
		*1-3/8	P-32-22
		*1-1/2	P-32-24
		*1-3/4	P-32-28
		*2-1/8	P-32-34

* **INFO+:** Counterbored, leaving correct drill-bearing length and clearance.

ID RANGE	OD	LENGTH	ANSI PART NO.
.2950-.3438 M-11/32 7.50-8.75mm	9/16 .5642-.5639 (.582-.577 UNG)	1/4	P-36-4
		5/16	P-36-5
		3/8	P-36-6
		1/2	P-36-8
		5/8	P-36-10
		3/4	P-36-12
		1	P-36-16
.3125-.4375 5/16-7/16 7.90-11.00mm	5/8 .6267-.6264 (.645-.640 UNG)	1/4	P-40-4
		5/16	P-40-5
		3/8	P-40-6
		1/2	P-40-8
		5/8	P-40-10
		3/4	P-40-12
		1	P-40-16
		1-1/4	P-40-20
		1-3/8	P-40-22
		1-1/2	P-40-24
		1-3/4	P-40-28
		2-1/8	P-40-34
.3125-.5312 5/16-17/32 7.90-13.50mm	3/4 .7518-.7515 (.770-.765 UNG)	1/4	P-48-4
		5/16	P-48-5
		3/8	P-48-6
		1/2	P-48-8
		5/8	P-48-10
		3/4	P-48-12
		1	P-48-16
		1-1/4	P-48-20
		1-3/8	P-48-22
		1-1/2	P-48-24
		1-3/4	P-48-28
		2-1/8	P-48-34
*2-1/2	P-48-40		
.5000-.6562 1/2-21/32 12.50-16.50mm	7/8 .8768-.8765 (.895-.890 UNG)	5/16	P-56-5
		3/8	P-56-6
		1/2	P-56-8
		5/8	P-56-10
		3/4	P-56-12
		1	P-56-16
		1-1/4	P-56-20
		1-3/8	P-56-22
		1-1/2	P-56-24
		1-3/4	P-56-28
		2-1/8	P-56-34
		2-1/2	P-56-40

CONTINUED ON NEXT PAGE

See also:
Round Carbide Pads, page 216

PRESS FIT BUSHINGS

ID RANGE	OD	LENGTH	ANSI PART NO.
.5000-.7656 1/2-49/64 12.50-19.50mm	1 1.0018-1.0015 (1.020-1.015 UNG)	1/2	P-64-8
		5/8	P-64-10
		3/4	P-64-12
		1	P-64-16
		1-1/4	P-64-20
		1-3/8	P-64-22
		1-1/2	P-64-24
		1-3/4	P-64-28
		2-1/8	P-64-34
		2-1/2	P-64-40
.7656-.8438 49/64-27/32 19.50-21.50mm	1-1/8 1.1270-1.1267 (1.145-1.140 UNG)	3	P-64-48
		1/2	P-72-8
		5/8	P-72-10
		3/4	P-72-12
		1	P-72-16
		1-1/4	P-72-20
		1-1/2	P-72-24
.8594-.9375 55/64-15/16 22.00-24.00mm	1-1/4 1.2520-1.2517 (1.270-1.265 UNG)	1-3/4	P-72-28
		5/8	P-80-10
		3/4	P-80-12
		1	P-80-16
		1-1/4	P-80-20
		1-1/2	P-80-24
		1-3/4	P-80-28
.6250-1.0312 5/8-1-1/32 16.00-26.00mm	1-3/8 1.3772-1.3768 (1.395-1.390 UNG)	2	P-80-32
		1/2	P-88-8
		5/8	P-88-10
		3/4	P-88-12
		1	P-88-16
		1-1/4	P-88-20
		1-3/8	P-88-22
		1-1/2	P-88-24
		1-3/4	P-88-28
		2	P-88-32
1.0156-1.1250 1-1/64-1-1/8 26.00-29.00mm	1-1/2 1.5021-1.5018 (1.520-1.515 UNG)	2-1/8	P-88-34
		2-1/2	P-88-40
		3	P-88-48
		3/4	P-96-12
		1	P-96-16
		1-1/4	P-96-20
		1-1/2	P-96-24
1-3/4	P-96-28		
		2	P-96-32
		2-1/4	P-96-36

* **INFO+:** Counterbored, leaving correct drill-bearing length and clearance.

ID RANGE	OD	LENGTH	ANSI PART NO.
1.0000-1.3906 1-1-25/64 25.00-35.00mm	1-3/4 1.7523-1.7519 (1.770-1.765 UNG)	3/4	P-112-12
		1	P-112-16
		1-3/8	P-112-22
		1-1/2	P-112-24
		1-3/4	P-112-28
		2-1/8	P-112-34
		2-1/2	P-112-40
		3	P-112-48
1.3750-1.7656 1-3/8-1-49/64 35.00-45.00mm	2-1/4 2.2525-2.2521 (2.270-2.265 UNG)	1	P-144-16
		1-3/8	P-144-22
		1-1/2	P-144-24
		1-3/4	P-144-28
		2-1/8	P-144-34
		2-1/2	P-144-40
		3	P-144-48

For extended-range bushings (larger sizes) please see our web catalog.

PRESS FIT BUSHINGS – CARBIDE



PC

ID RANGE	OD	LENGTH	ANSI PART NO.
.0280-.0468 #70-#56 .75-1.15mm	5/32 .1578-.1575	5/16	PC-10-5
		1/2	PC-10-8
.0469-.0625 3/64-1/16 1.20-1.55mm	5/32 .1578-.1575	5/16	PC-10-5
		1/2	PC-10-8
.0550-.0995 #54-#39 1.40-2.50mm	13/64 .2046-.2043	5/16	PC-13-5
		1/2	PC-13-8
.0995-.1360 #39-#29 2.55-3.40mm	1/4 .2516-.2513	5/16	PC-16-5
		1/2	PC-16-8
.1285-.1875 #30-3/16 3.30-4.75mm	5/16 .3141-.3138	5/16	PC-20-5
		1/2	PC-20-8
		3/4	PC-20-12
		1	PC-20-16
.1875-.2500 3/16-1/4 4.80-6.30mm	13/32 .4078-.4075	5/16	PC-26-5
		1/2	PC-26-8
		3/4	PC-26-12
		1	PC-26-16
.2188-.3125 7/32-5/16 5.60-7.90mm	1/2 .5017-.5014	5/16	PC-32-5
		1/2	PC-32-8
		3/4	PC-32-12
		1	PC-32-16
		1-3/8	PC-32-22
.3125-.4219 5/16-27/64 8.00-10.50mm	5/8 .6267-.6264	1/2	PC-40-8
		3/4	PC-40-12
		1	PC-40-16
		1-3/8	PC-40-22
.3750-.5000 3/8-1/2 9.60-12.50mm	3/4 .7518-.7515	1/2	PC-48-8
		3/4	PC-48-12
		1	PC-48-16
		1-3/8	PC-48-22
.5000-.6250 1/2-5/8 13.00-15.50mm	7/8 .8768-.8765	1/2	PC-56-8
		3/4	PC-56-12
		1	PC-56-16
		1-3/8	PC-56-22
		1-3/4	PC-56-28

ID RANGE	OD	LENGTH	ANSI PART NO.
.5000-.7500 1/2-3/4 13.00-19.00mm	1 1.0018-1.0015	1/2	PC-64-8
		3/4	PC-64-12
		1	PC-64-16
		1-3/8	PC-64-22
.7500-1.0000 3/4-1 19.50-25.00mm	1-3/8 1.3772-1.3768	1-3/4	PC-64-28
		3/4	PC-88-12
		1	PC-88-16
		1-3/8	PC-88-22
1.0000-1.3750 1-1-3/8 26.00-34.00mm	1-3/4 1.7523-1.7519	1-3/4	PC-88-28
		2-1/8	PC-88-34
		2-1/2	PC-88-40
		1	PC-88-40
1.0000-1.3750 1-1-3/8 26.00-34.00mm	1-3/4 1.7523-1.7519	1	PC-112-16
		1-3/8	PC-112-22
		1-3/4	PC-112-28
		2-1/8	PC-112-34
		2-1/2	PC-112-40
1.3750-1.7500 1-3/8-1-3/4 35.00-44.00mm	2-1/4 2.2525-2.2521	3	PC-112-48
		1	PC-144-16
		1-3/8	PC-144-22
		1-3/4	PC-144-28
		2-1/8	PC-144-34
1.3750-1.7500 1-3/8-1-3/4 35.00-44.00mm	2-1/4 2.2525-2.2521	2-1/2	PC-144-40
		3	PC-144-48
		3	PC-144-48

PRESS FIT BUSHINGS – METRIC



PM

ID RANGE (G6)	OD (s6)	LENGTH	ANSI PART NO.
.35-1.00mm	4mm	*6mm	PM-4-6
		*9mm	PM-4-9
1.01-1.80mm	4.027-4.019mm	6mm	PM-4-6
		9mm	PM-4-9
1.81-2.60mm	5mm	6mm	PM-5-6
		9mm	PM-5-9
2.61-3.30mm	5.027-5.019mm	8mm	PM-6-8
		12mm	PM-6-12
		16mm	PM-6-16
3.31-4.00mm	7mm	8mm	PM-7-8
		12mm	PM-7-12
		16mm	PM-7-16
4.01-5.00mm	8mm	8mm	PM-8-8
		12mm	PM-8-12
		16mm	PM-8-16
5.01-6.00mm	10mm	10mm	PM-10-10
		16mm	PM-10-16
		20mm	PM-10-20
6.01-8.00mm	12mm	10mm	PM-12-10
		16mm	PM-12-16
		20mm	PM-12-20
8.01-10.00mm	15mm	12mm	PM-15-12
		20mm	PM-15-20
		25mm	PM-15-25
10.01-12.00mm	18mm	12mm	PM-18-12
		20mm	PM-18-20
		25mm	PM-18-25
12.01-15.00mm	22mm	16mm	PM-22-16
		28mm	PM-22-28
		36mm	PM-22-36
15.01-18.00mm	26mm	16mm	PM-26-16
		28mm	PM-26-28
		36mm	PM-26-36
18.01-22.00mm	30mm	20mm	PM-30-20
		36mm	PM-30-36
		45mm	PM-30-45
22.01-26.00mm	35mm	20mm	PM-35-20
		36mm	PM-35-36
		45mm	PM-35-45
26.01-30.00mm	42mm	25mm	PM-42-25
		45mm	PM-42-45
		56mm	PM-42-56
30.01-35.00mm	48mm	25mm	PM-48-25
		45mm	PM-48-45
		56mm	PM-48-56
35.01-42.00mm	55mm	30mm	PM-55-30
		56mm	PM-55-56
		67mm	PM-55-67
42.01-48.00mm	62mm	30mm	PM-62-30
		56mm	PM-62-56
		67mm	PM-62-67

ID RANGE (G6)	OD (s6)	LENGTH	ANSI PART NO.
48.01-55.00mm	70mm	30mm	PM-70-30
		56mm	PM-70-56
		67mm	PM-70-67
55.01-63.00mm	78mm	35mm	PM-78-35
		67mm	PM-78-67
		78mm	PM-78-78
63.01-70.00mm	85mm	35mm	PM-85-35
		67mm	PM-85-67
		78mm	PM-85-78
70.01-78.00mm	95mm	40mm	PM-95-40
		78mm	PM-95-78
		105mm	PM-95-105
78.01-85.00mm	105mm	40mm	PM-105-40
		78mm	PM-105-78
		105mm	PM-105-105
85.01-95.00mm	115mm	45mm	PM-115-45
		89mm	PM-115-89
		112mm	PM-115-112
95.01-105.00mm	125mm	45mm	PM-125-45
		89mm	PM-125-89
		112mm	PM-125-112

* Small metric drill sizes through .80mm are counterbored 1.00mm diameter, with 3mm drill-bearing length.

HEAD PRESS FIT BUSHINGS

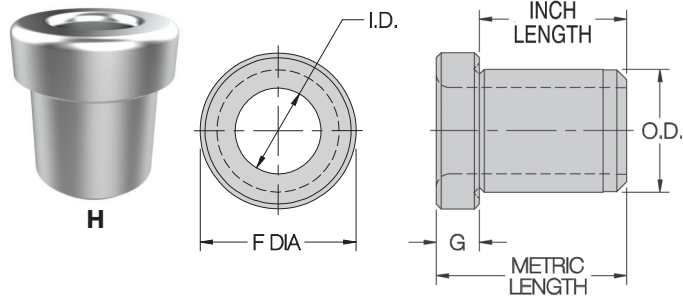

ORDERING EXAMPLES:

H-20-16-.1250	Standard inch bushing, inch ID
H-20-16-.1772	Standard inch bushing, mm ID (.1772 = 4.50mm)
H-20-16U-.1250	Unground OD
H-20-16-.1250 REAMER	Reamer tolerance on ID
H-20-16-.1250 NCB	No counterbore on long bushings marked with * (no counterbore is standard on all other bushings)
HC-20-16-.1250	Carbide bushing
HM-8-12-4.50	Standard metric bushing

Standard prices apply only to bushings with a standard-drill-size ID within the stated ID range. See catalog back cover for standard drill sizes and their decimal equivalents. For prices on non-standard ID sizes, including reamer-tolerance and tap-guide bushings, please contact factory.

INCH

BODY OD	F DIA	G
5/32	1/4	3/32
13/64	19/64	3/32
1/4	23/64	3/32
5/16	27/64	1/8
3/8	1/2	3/32
13/32	1/2	5/32
7/16	9/16	3/32
1/2	39/64	7/32
9/16	11/16	3/32
5/8	51/64	7/32
3/4	59/64	7/32
7/8	1-7/64	1/4
1	1-15/64	5/16
1-1/4	1-1/2	1/4
1-3/8	1-39/64	3/8
1-3/4	1-63/64	3/8
2-1/4	2-31/64	3/8

METRIC

BODY OD	F DIA	G
4mm	7mm	2mm
5mm	8mm	2mm
6mm	9mm	2.5mm
7mm	10mm	2.5mm
8mm	11mm	2.5mm
10mm	13mm	3mm
12mm	15mm	3mm
15mm	18mm	3mm
18mm	22mm	4mm
22mm	26mm	4mm
26mm	30mm	4mm
30mm	34mm	5mm
35mm	39mm	5mm
42mm	46mm	5mm
48mm	52mm	5mm
55mm	59mm	5mm
62mm	66mm	6mm
70mm	74mm	6mm
78mm	82mm	6mm
85mm	90mm	6mm
95mm	100mm	6mm
105mm	110mm	6mm
115mm	120mm	6mm
125mm	130mm	6mm

APPLICATIONS:

Similar to a P bushing, but with a head to resist heavy axial loads. H bushings are permanently pressed into the jig plate. They are generally used for single-step drilling or reaming operations when you do not expect to replace bushings during the tooling's lifetime. The head can be left exposed, or recessed by counterboring the installation hole.

Note: The "length" listed for an inch head-press-fit bushing refers to its length under the head, while the metric version's "length" is its overall length.

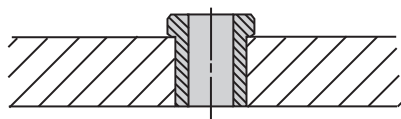

STANDARD ID TOLERANCES:

From #80 to 1/4"	+0.001/+0.004	From .35 to 3mm	+0.02/+0.08mm
Over 1/4 to 3/4"	+0.001/+0.005	Over 3 to 6mm	+0.04/+0.12mm
Over 3/4 to 1-1/2"	+0.002/+0.006	Over 6 to 10mm	+0.05/+0.14mm
Over 1-1/2 to 2-3/4"	+0.003/+0.007	Over 10 to 18mm	+0.06/+0.17mm
		Over 18 to 30mm	+0.07/+0.20mm
		Over 30 to 50mm	+0.09/+0.25mm
		Over 50 to 80mm	+0.10/+0.29mm
		Over 80 to 120mm	+0.12/+0.34mm
		(G6 tolerance)	

REAMER ID TOLERANCES:

From #60 to 1/4"	+0.005/+0.008	From 1 to 3mm	+0.06/+0.12mm
Over 1/4 to 1"	+0.006/+0.010	Over 3 to 6mm	+0.10/+0.18mm
Over 1 to 1-1/2"	+0.008/+0.012	Over 6 to 10mm	+0.13/+0.22mm
		Over 10 to 18mm	+0.16/+0.27mm
		Over 18 to 30mm	+0.20/+0.33mm
		(F6 tolerance)	

ID RANGE	OD	LENGTH	ANSI PART NO.
.0135-.0291 #80-#70 .35-.70mm	5/32 .1578-.1575 (.166-.161 UNG)	1/4	H-10-4
		5/16	H-10-5
		*3/8	H-10-6
		*1/2	H-10-8
.0292-.0519 #69-3/64 .75-1.25mm		1/4	H-10-4
		5/16	H-10-5
		*3/8	H-10-6
		*1/2	H-10-8
.0520-.0625 #55-1/16 1.30-1.60mm		*3/4	H-10-12
		1/4	H-10-4
		5/16	H-10-5
		3/8	H-10-6
		*1/2	H-10-8
		*3/4	H-10-12

* **INFO+**: Counterbored, leaving correct drill-bearing length and clearance.

CONTINUED ON NEXT PAGE

HEAD PRESS FIT BUSHINGS

ID RANGE	OD	LENGTH	ANSI PART NO.
.0135-.0291 #80-#70 .35-.70mm	13/64 .2046-.2043 (.213-.208 UNG)	1/4	H-13-4
		5/16	H-13-5
		*3/8	H-13-6
		*1/2	H-13-8
.0292-.0519 #69-3/64 .75-1.30mm		1/4	H-13-4
		5/16	H-13-5
		*3/8	H-13-6
		*1/2	H-13-8
.0520-.0634 #55-1/16 1.35-1.60mm		*3/4	H-13-12
		1/4	H-13-4
		5/16	H-13-5
		3/8	H-13-6
.0635-.0995 #52-#39 1.65-2.50mm	*1/2	H-13-8	
	*3/4	H-13-12	
	*1	H-13-16	
	1/4	H-13-4	
.0980-.1406 #40-9/64 2.50-3.50mm	5/16	H-13-5	
	3/8	H-13-6	
	*1/2	H-13-8	
	*3/4	H-13-12	
	*1	H-13-16	
	1/4	H-16-4	
	5/16	H-16-5	
.1250-.1935 1/8-#10 3.20-4.90mm	3/8	H-16-6	
	*1/2	H-16-8	
	*5/8	H-16-10	
	*3/4	H-16-12	
	*1	H-16-16	
	*1-3/8	H-16-22	
	*1-1/2	H-16-24	
.1935-.2280 #10-#1 4.90-5.80mm	1/4	H-20-4	
	5/16	H-20-5	
	3/8	H-20-6	
	1/2	H-20-8	
	5/8	H-20-10	
	3/4	H-20-12	
	*1	H-20-16	
	*1-3/8	H-20-22	
.1875-.2570 3/16-F 4.75-6.50mm	*1-1/2	H-20-24	
	1/4	H-24-4	
	5/16	H-24-5	
	3/8	H-24-6	
	1/2	H-24-8	
	5/8	H-24-10	
	3/4	H-24-12	
	*1	H-24-16	
	1/4	H-26-4	
	5/16	H-26-5	
.1875-.2570 3/16-F 4.75-6.50mm	3/8	H-26-6	
	1/2	H-26-8	
	3/4	H-26-12	
	*1	H-26-16	
	*1-3/8	H-26-22	
	*1-1/2	H-26-24	
	*1-3/4	H-26-28	
	1/4	H-26-4	

ID RANGE	OD	LENGTH	ANSI PART NO.
.2340-.2900 A-L 5.90-7.40mm	7/16 .4392-.4389 (.453-.448 UNG)	1/4	H-28-4
		5/16	H-28-5
		3/8	H-28-6
		1/2	H-28-8
		5/8	H-28-10
		3/4	H-28-12
.1875-.3160 3/16-O 4.75-8.00mm	1/2 .5017-.5014 (.520-.515 UNG)	*1	H-28-16
		1/4	H-32-4
		5/16	H-32-5
		3/8	H-32-6
		1/2	H-32-8
		3/4	H-32-12
.2950-.3438 M-11/32 7.50-8.75mm	9/16 .5642-.5639 (.582-.577 UNG)	*1	H-32-16
		*1-3/8	H-32-22
		*1-1/2	H-32-24
		*1-3/4	H-32-28
		1/4	H-36-4
		5/16	H-36-5
.3125-.4375 5/16-7/16 7.90-11.00mm	5/8 .6267-.6264 (.645-.640 UNG)	3/8	H-36-6
		1/2	H-36-8
		5/8	H-36-10
		3/4	H-36-12
		1	H-36-16
		1/4	H-40-4
.3125-.5312 5/16-17/32 7.90-13.50mm	3/4 .7518-.7515 (.770-.765 UNG)	5/16	H-40-5
		3/8	H-40-6
		1/2	H-40-8
		5/8	H-40-10
		3/4	H-40-12
		1	H-40-16
		1-3/8	H-40-22
		1-1/2	H-40-24
1/4	H-48-4		
5/16	H-48-5		
3/8	H-48-6		
1/2	H-48-8		
5/8	H-48-10		
3/4	H-48-12		
1	H-48-16		
1-1/4	H-48-20		
1-3/8	H-48-22		
1-1/2	H-48-24		
1-3/4	H-48-28		
2-1/8	H-48-34		

CONTINUED ON NEXT PAGE

* **INFO+**: Counterbored, leaving correct drill-bearing length and clearance (see page 537 for bearing length).

HEAD PRESS FIT BUSHINGS

ID RANGE	OD	LENGTH	ANSI PART NO.
.5000-.6562 1/2-21/32 12.50-16.50mm	7/8 .8768-.8765 (.895-.890 UNG)	1/2	H-56-8
		5/8	H-56-10
		3/4	H-56-12
		1	H-56-16
		1-1/4	H-56-20
		1-3/8	H-56-22
		1-1/2	H-56-24
		1-3/4	H-56-28
		2-1/8	H-56-34
	2-1/2	H-56-40	
.5000-.7656 1/2-49/64 12.50-19.50mm	1 1.0018-1.0015 (1.020-1.015 UNG)	1/2	H-64-8
		3/4	H-64-12
		1	H-64-16
		1-3/8	H-64-22
		1-1/2	H-64-24
		1-3/4	H-64-28
		2-1/8	H-64-34
		2-1/2	H-64-40
		3	H-64-48
.8594-.9375 55/64-15/16 22.00-24.00mm	1-1/4 1.2520-1.2517 (1.270-1.265 UNG)	5/8	H-80-10
		3/4	H-80-12
		1	H-80-16
		1-1/4	H-80-20
		1-1/2	H-80-24
		1-3/4	H-80-28
		2	H-80-32
.6250-1.0312 5/8-1-1/32 16.00-26.00mm	1-3/8 1.3772-1.3768 (1.395-1.390 UNG)	1/2	H-88-8
		3/4	H-88-12
		1	H-88-16
		1-3/8	H-88-22
		1-1/2	H-88-24
		1-3/4	H-88-28
		2-1/8	H-88-34
		2-1/2	H-88-40
		3	H-88-48
1.0000-1.3906 1-1-25/64 26.00-35.00mm	1-3/4 1.7523-1.7519 (1.770-1.765 UNG)	3/4	H-112-12
		1	H-112-16
		1-3/8	H-112-22
		1-1/2	H-112-24
		1-3/4	H-112-28
		2-1/8	H-112-34
		2-1/2	H-112-40
1.3750-1.7656 1-3/8-1-49/64 35.00-45.00mm	2-1/4 2.2525-2.2521 (2.270-2.265 UNG)	1	H-144-16
		1-3/8	H-144-22
		1-1/2	H-144-24
		1-3/4	H-144-28
		2-1/8	H-144-34
		2-1/2	H-144-40
		3	H-144-48

For extended-range bushings (larger sizes) please see our web catalog.

HEAD PRESS FIT BUSHINGS – CARBIDE



HC

ID RANGE	OD	LENGTH	ANSI PART NO.
.0280-.0468 #70-#56 .75-1.15mm	5/32 .1578-.1575	5/16	HC-10-5
		1/2	HC-10-8
.0469-.0625 3/64-1/16 1.20-1.55mm	5/32 .1578-.1575	5/16	HC-10-5
		1/2	HC-10-8
.0550-.0995 #54-#39 1.40-2.50mm	13/64 .2046-.2043	5/16	HC-13-5
		1/2	HC-13-8
.0995-.1360 #39-#29 2.55-3.40mm	1/4 .2516-.2513	5/16	HC-16-5
		1/2	HC-16-8
.1285-.1875 #30-3/16 3.30-4.75mm	5/16 .3141-.3138	5/16	HC-20-5
		1/2	HC-20-8
		3/4	HC-20-12
		1	HC-20-16
.1875-.2500 3/16-1/4 4.80-6.30mm	13/32 .4078-.4075	5/16	HC-26-5
		1/2	HC-26-8
		3/4	HC-26-12
		1	HC-26-16
.2188-.3125 7/32-5/16 5.60-7.90mm	1/2 .5017-.5014	5/16	HC-32-5
		1/2	HC-32-8
		3/4	HC-32-12
		1	HC-32-16
		1-3/8	HC-32-22
.3125-.4219 5/16-27/64 8.00-10.50mm	5/8 .6267-.6264	1/2	HC-40-8
		3/4	HC-40-12
		1	HC-40-16
		1-3/8	HC-40-22
.3750-.5000 3/8-1/2 9.60-12.50mm	3/4 .7518-.7515	1/2	HC-48-8
		3/4	HC-48-12
		1	HC-48-16
		1-3/8	HC-48-22
.5000-.6250 1/2-5/8 13.00-15.50mm	7/8 .8768-.8765	1/2	HC-56-8
		3/4	HC-56-12
		1	HC-56-16
		1-3/8	HC-56-22
		1-3/4	HC-56-28

ID RANGE	OD	LENGTH	ANSI PART NO.
.5000-.7500 1/2-3/4 13.00-19.00mm	1 1.0018-1.0015	1/2	HC-64-8
		3/4	HC-64-12
		1	HC-64-16
		1-3/8	HC-64-22
		1-3/4	HC-64-28
.7500-1.0000 3/4-1 19.50-25.00mm	1-3/8 1.3772-1.3768	3/4	HC-88-12
		1	HC-88-16
		1-3/8	HC-88-22
		1-3/4	HC-88-28
		2-1/8	HC-88-34
1.0000-1.3750 1-1-3/8 26.00-34.00mm	1-3/4 1.7523-1.7519	2-1/2	HC-88-40
		1	HC-112-16
		1-3/8	HC-112-22
		1-3/4	HC-112-28
		2	HC-112-32
1.3750-1.7500 1-3/8-1-3/4 35.00-44.00mm	2-1/4 2.2525-2.2521	2-1/8	HC-112-34
		2-1/2	HC-112-40
		3	HC-112-48
		1	HC-144-16
		1-3/8	HC-144-22
		1-3/4	HC-144-28
		2-1/8	HC-144-34
		2-1/2	HC-144-40
		3	HC-144-48

Note: Due to manufacturing requirements, head dimensions of some carbide bushings may differ slightly from ANSI standards. Most carbide bushings have steel heads.

HEAD PRESS FIT BUSHINGS – METRIC



HM

ID RANGE (G6)	OD (s6)	LENGTH	ANSI PART NO.
.35-1.00mm	4mm	*6mm	HM-4-6
		*9mm	HM-4-9
1.01-1.80mm	4.027-4.019mm	6mm	HM-4-6
		9mm	HM-4-9
1.81-2.60mm	5mm	6mm	HM-5-6
		9mm	HM-5-9
2.61-3.30mm	6mm	8mm	HM-6-8
		12mm	HM-6-12
3.31-4.00mm	7mm	16mm	HM-6-16
		8mm	HM-7-8
4.01-5.00mm	8mm	12mm	HM-7-12
		16mm	HM-7-16
5.01-6.00mm	10mm	8mm	HM-8-8
		12mm	HM-8-12
6.01-8.00mm	12mm	16mm	HM-8-16
		10mm	HM-10-10
8.01-10.00mm	15mm	16mm	HM-10-16
		20mm	HM-10-20
10.01-12.00mm	18mm	20mm	HM-10-20
		25mm	HM-10-25
12.01-15.00mm	22mm	12mm	HM-12-12
		20mm	HM-12-20
15.01-18.00mm	26mm	25mm	HM-12-25
		16mm	HM-15-16
18.01-22.00mm	30mm	28mm	HM-15-28
		36mm	HM-15-36
22.01-26.00mm	35mm	16mm	HM-16-16
		20mm	HM-16-20
26.01-30.00mm	42mm	28mm	HM-16-28
		36mm	HM-16-36
30.01-35.00mm	48mm	45mm	HM-16-45
		20mm	HM-20-20
35.01-42.00mm	55mm	36mm	HM-20-36
		45mm	HM-20-45
42.01-48.00mm	62mm	56mm	HM-20-56
		67mm	HM-20-67

* **INFO+**: Counterbored, leaving correct drill-bearing length and clearance (see page 537 for bearing length).

ID RANGE (G6)	OD (s6)	LENGTH	ANSI PART NO.
48.01-55.00mm	70mm 70.078-70.059mm	30mm	HM-70-30
		56mm	HM-70-56
		67mm	HM-70-67
55.01-63.00mm	78mm 78.078-78.059mm	35mm	HM-78-35
		67mm	HM-78-67
		78mm	HM-78-78
63.01-70.00mm	85mm 85.093-85.071mm	35mm	HM-85-35
		67mm	HM-85-67
		78mm	HM-85-78
70.01-78.00mm	95mm 95.093-95.071mm	40mm	HM-95-40
		78mm	HM-95-78
		105mm	HM-95-105
78.01-85.00mm	105mm 105.101-105.079mm	40mm	HM-105-40
		78mm	HM-105-78
		105mm	HM-105-105
85.01-95.00mm	115mm 115.101-115.079mm	45mm	HM-115-45
		89mm	HM-115-89
		112mm	HM-115-112
95.01-105.00mm	125mm 125.117-125.092mm	45mm	HM-125-45
		89mm	HM-125-89
		112mm	HM-125-112

* Small metric drill sizes through .80mm are counterbored 1.00mm diameter, with 3mm drill-bearing length.

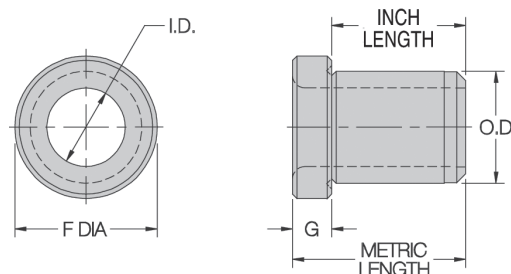

Note: The "length" listed on this page for a metric head-press-fit bushing refers to its overall length, while the inch version's "length" is its length under the head.

SERRATED PRESS FIT BUSHINGS

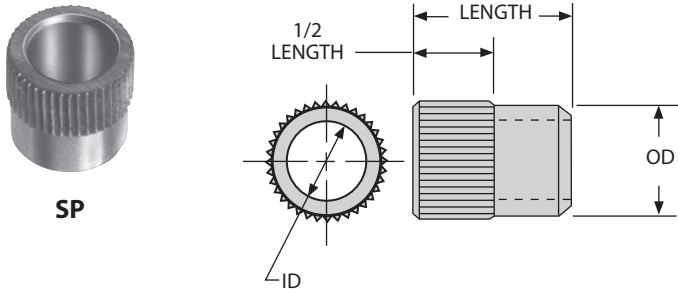

APPLICATIONS:

Similar to a P bushing, but with top serrations to prevent rotation in soft materials. Recommended in high-torque situations for materials such as magnesium, aluminum, masonite, or wood. Finish-ground OD ensures accurate ID location. Serrations also resist axial force to prevent pushing the bushing through the jig plate.

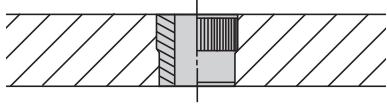

ORDERING EXAMPLES:

SP-26-16-.1875	Standard inch bushing, inch ID
SP-26-16-.1772	Standard inch bushing, mm ID (.1772 - 4.50mm)
SP-26-16-.1875 REAMER	Reamer tolerance on ID
SP-26-16-.1875 NCB	No counterbore on long bushings marked with * (no counterbore is standard on all other bushings)
SPM-8-12-4.50	Standard metric bushing

Standard prices apply only to bushings with a standard-drill-size ID within the stated ID range. See catalog back cover for standard drill sizes and their decimal equivalents. For prices on non-standard ID sizes, including reamer-tolerance and tap-guide bushings, please contact factory.

STANDARD ID TOLERANCES:

From #55 to 1/4"	+ .0001/+ .0004	From 1 to 3mm	+ .002/+ .008mm
		Over 3 to 6mm	+ .004/+ .012mm
Over 1/4 to 3/4"	+ .0001/+ .0005	Over 6 to 10mm	+ .005/+ .014mm
		Over 10 to 18mm	+ .006/+ .017mm
Over 3/4 to 1-1/2"	+ .0002/+ .0006	Over 18 to 19mm	+ .007/+ .020mm
			(G6 tolerance)

REAMER ID TOLERANCES:

From #60 to 1/4"	+ .0005/+ .0008	From 1 to 3mm	+ .006/+ .012mm
		Over 3 to 6mm	+ .010/+ .018mm
Over 1/4 to 1"	+ .0006/+ .0010	Over 6 to 10mm	+ .013/+ .022mm
		Over 10 to 18mm	+ .016/+ .027mm
		Over 18 to 19mm	+ .020/+ .033mm
			(F6 tolerance)

ID RANGE	OD	LENGTH	ANSI PART NO.
.0520-.0995 #55-#39 1.35-2.50mm	13/64 .2031-.2029	1/4	SP-13-4
		5/16	SP-13-5
		3/8	SP-13-6
		1/2	SP-13-8
.0980-.1406 #40-9/64 2.50-3.50mm	1/4 .2500-.2498	1/4	SP-16-4
		5/16	SP-16-5
		3/8	SP-16-6
		1/2	SP-16-8
.1250-.1935 1/8-#10 3.20-4.90mm	5/16 .3125-.3123	1/4	SP-20-4
		5/16	SP-20-5
		3/8	SP-20-6
		1/2	SP-20-8
		3/4	SP-20-12
.1562-.2570 5/32-F 4.00-6.50mm	13/32 .4062-.4060	5/16	SP-26-5
		3/8	SP-26-6
		1/2	SP-26-8
		3/4	SP-26-12
		*1	SP-26-16
.1562-.3160 5/32-O 4.00-8.00mm	1/2 .5000-.4998	5/16	SP-32-5
		3/8	SP-32-6
		1/2	SP-32-8
		3/4	SP-32-12
		*1	SP-32-16
.3125-.4375 5/16-7/16 7.90-11.00mm	5/8 .6250-.6248	3/8	SP-40-6
		1/2	SP-40-8
		3/4	SP-40-12
		1	SP-40-16
.3125-.5312 5/16-17/32 8.00-13.00mm	3/4 .7500-.7498	3/8	SP-48-6
		1/2	SP-48-8
		3/4	SP-48-12
		1	SP-48-16
.5000-.6562 1/2-21/32 13.00-16.50mm	7/8 .8750-.8748	3/8	SP-56-6
		1/2	SP-56-8
		3/4	SP-56-12
		1	SP-56-16
.5000-.7656 1/2-49/64 13.00-19.00mm	1 1.0000-.9998	1/2	SP-64-8
		3/4	SP-64-12
		1	SP-64-16
		1-3/8	SP-64-22

* **INFO+**: Counterbored, leaving correct drill-bearing length and clearance.

SERRATED PRESS FIT BUSHINGS – METRIC



SPM

ID RANGE (G6)	OD (h5)	LENGTH	ANSI PART NO.
1.00-1.80mm	5mm	6mm	SPM-5-6
		9mm	SPM-5-9
1.81-2.60mm	5.000-4.995mm	6mm	SPM-5-6
		9mm	SPM-5-9
2.61-3.30mm	6.000-5.995mm	8mm	SPM-6-8
		12mm	SPM-6-12
		16mm	SPM-6-16
3.31-4.00mm	7.000-6.994mm	8mm	SPM-7-8
		12mm	SPM-7-12
		16mm	SPM-7-16
4.01-5.00mm	8.000-7.994mm	8mm	SPM-8-8
		12mm	SPM-8-12
		16mm	SPM-8-16
5.01-6.00mm	10.000-9.994mm	10mm	SPM-10-10
		16mm	SPM-10-16
		20mm	SPM-10-20
6.01-8.00mm	12.000-11.992mm	10mm	SPM-12-10
		16mm	SPM-12-16
		20mm	SPM-12-20
8.01-10.00mm	15.000-14.992mm	12mm	SPM-15-12
		20mm	SPM-15-20
		25mm	SPM-15-25
10.01-12.00mm	18.000-17.992mm	12mm	SPM-18-12
		20mm	SPM-18-20
		25mm	SPM-18-25
12.01-15.00mm	22.000-21.991mm	16mm	SPM-22-16
		28mm	SPM-22-28
		36mm	SPM-22-36
15.01-18.00mm	26.000-25.991mm	16mm	SPM-26-16
		28mm	SPM-26-28
		36mm	SPM-26-36

Discover Solutions at CarrLane.com

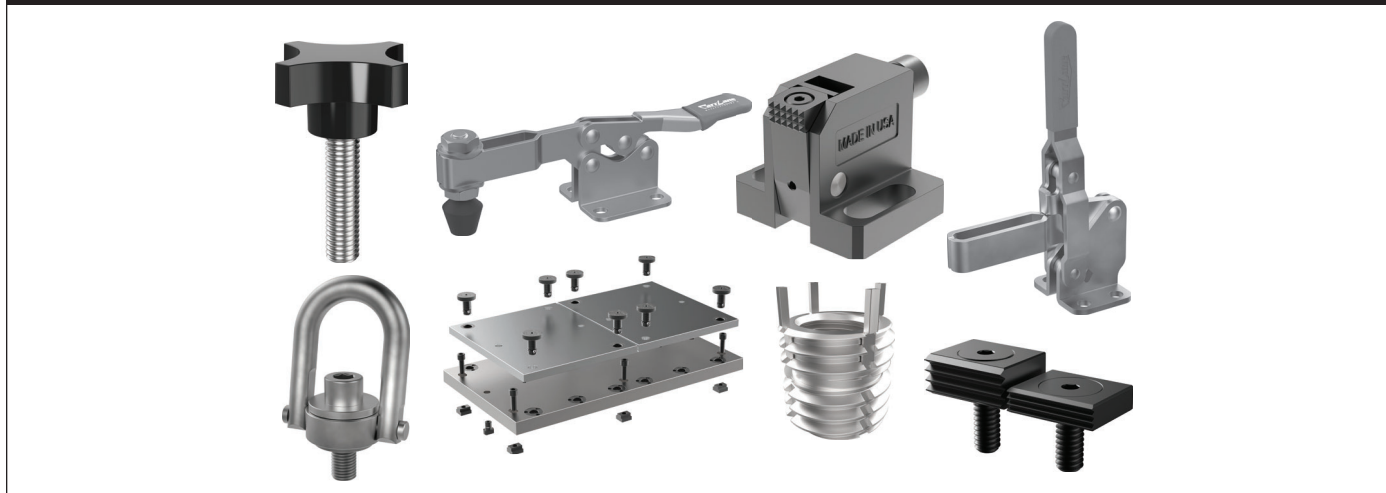

SLIP/FIXED RENEWABLE BUSHINGS

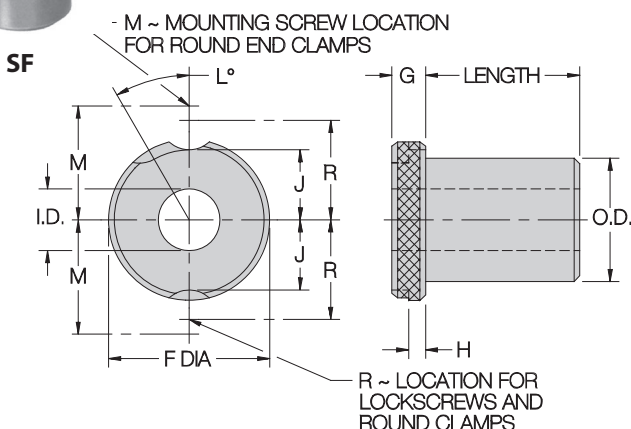

APPLICATIONS:

Replaceable bushing generally used with a liner bushing and lock screw. Use when you expect to replace bushings during the tooling's lifetime, or when you want to switch bushings to perform multi-step operations with the same tooling. SF bushings combine the benefits of older S-type slip-renewable and F-type fixed-renewable bushings: One side has a small recess for fixed mounting; the other has a locking recess that allows the bushing to slip down, then lock in place by rotating it. S and F types are now obsolete and combination SF bushings will be furnished at no extra charge.

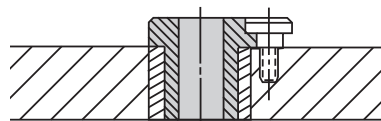

ORDERING EXAMPLES:

- SF-20-16-.1250 Standard inch bushing, inch ID
- SF-20-16-.1772 Standard inch bushing, mm ID (.1772 = 4.50mm)
- SF-20-16-.1250 REAMER Reamer tolerance on ID
- SF-20-16-.1250 NCB No counterbore on long bushings marked with * (no counterbore is standard on all other bushings)
- SFC-20-16-.1250 Carbide bushing
- SFM-8-16-4.50 Standard metric bushing

Standard prices apply only to bushings with a standard-drill-size ID within the stated ID range. See catalog back cover for standard drill sizes and their decimal equivalents. For prices on non-standard ID sizes, including reamer-tolerance and tap-guide bushings, please contact factory.

STANDARD ID TOLERANCES:

From #80 to 1/4"	+0.001/+0.004	From .35 to 3mm	+0.02/+0.08mm
Over 1/4 to 3/4"	+0.001/+0.005	Over 3 to 6mm	+0.04/+0.12mm
Over 3/4 to 1-1/2"	+0.002/+0.006	Over 6 to 10mm	+0.05/+0.14mm
Over 1-1/2 to 2-3/4"	+0.003/+0.007	Over 10 to 18mm	+0.06/+0.17mm
		Over 18 to 30mm	+0.07/+0.20mm
		Over 30 to 50mm	+0.09/+0.25mm
		Over 50 to 80mm	+0.10/+0.29mm
		Over 80 to 120mm	+0.12/+0.34mm
		(G6 tolerance)	

REAMER ID TOLERANCES:

From #60 to 1/4"	+0.005/+0.008	From 1 to 3mm	+0.06/+0.12mm
Over 1/4 to 1"	+0.006/+0.010	Over 3 to 6mm	+0.10/+0.18mm
Over 1 to 1-1/2"	+0.008/+0.012	Over 6 to 10mm	+0.13/+0.22mm
		Over 10 to 18mm	+0.16/+0.27mm
		Over 18 to 30mm	+0.20/+0.33mm
		(F6 tolerance)	

INCH

BODY OD	F DIA	G	H	J	L	M	R	LOCK SCREW		
3/16	5/16	3/16	3/32	3/32	55°		17/64	LS-0		
1/4	7/16	1/4	1/8	9/64	30°		23/64	TW-2		
5/16	35/64			11/64	65°	5/8	1/2	LS-1		
3/8	5/8			15/64	30°		29/64	TW-2		
7/16	5/8			15/64	30°		29/64	TW-2		
1/2	51/64			19/64	65°	3/4	5/8	LS-1		
9/16	7/8			23/64	65°		37/64	TW-2		
5/8	7/8			23/64	30°		37/64	TW-2		
3/4	1-3/64			27/64	50°	7/8	3/4	LS-1		
7/8	1-1/4			3/8	3/16	31/64	30°		53/64	TW-7
1	1-27/64					19/32	35°	1-7/64	59/64	LS-2
1-1/4	1-5/8	43/64	30°				1-1/64			
1-3/8	1-51/64	25/32	30°			1-19/64	1-7/64			
1-1/2	1-7/8	51/64	30°				1-9/64			
1-3/4	2-19/64	3/8	3/16			1	30°	1-41/64	1-25/64	LS-3
2-1/4	2-51/64					1-1/4	25°	1-57/64	1-41/64	

METRIC

8mm	15mm	6mm	3mm	4.5mm	65°	11.5mm	LSM-1		
10mm	18mm			6mm	65°		13mm	LSM-2	
12mm	22mm	8mm	4mm	7.5mm	60°	16mm	LSM-3		
15mm	26mm			9.5mm	50°	18mm	LSM-4		
18mm	30mm			11.5mm	50°	20mm			
22mm	34mm			10mm	5.5mm	13mm	35°	23.5mm	LSM-5
26mm	39mm	15.5mm	35°			26mm	LSM-6		
30mm	46mm	19mm	30°			29.5mm			
35mm	52mm	22mm	30°			32.5mm			
42mm	59mm	25.5mm	30°			36mm			
48mm	66mm	12mm	7mm			28.5mm	30°	41mm	LSM-7
55mm	74mm					32.5mm	25°	45mm	LSM-8
62mm	82mm					36.5mm	25°	49mm	
70mm	90mm					40.5mm	25°	53mm	
78mm	100mm					45.5mm	25°	58mm	
85mm	110mm			50.5mm	20°	63mm			
95mm	120mm			55.5mm	20°	68mm			
105mm	130mm			60.5mm	20°	73mm			

SLIP/FIXED RENEWABLE BUSHINGS

ID RANGE	OD	LENGTH	ANSI PART NO.	LOCK SCREW
.0135-.0291 #80-#70 .35-.70mm	3/16 .1875-.1873	*1/4	SF-12-4	LS-0
		*5/16	SF-12-5	
		*3/8	SF-12-6	
		*1/2	SF-12-8	
		*5/8	SF-12-10	
		*3/4	SF-12-12	
.0292-.0519 #69-3/64 .75-1.25mm		1/4	SF-12-4	
		*5/16	SF-12-5	
		*3/8	SF-12-6	
		*1/2	SF-12-8	
		*5/8	SF-12-10	
		*3/4	SF-12-12	
.0520-.0634 #55-1/16 1.30-1.60mm		1/4	SF-12-4	
		*5/16	SF-12-5	
		*3/8	SF-12-6	
		*1/2	SF-12-8	
		*5/8	SF-12-10	
		*3/4	SF-12-12	
.0635-.0980 #52-#40 1.65-2.50mm	1/4	SF-12-4		
	*5/16	SF-12-5		
	*3/8	SF-12-6		
	*1/2	SF-12-8		
	*5/8	SF-12-10		
	*3/4	SF-12-12		
.0995-.1405 #39-#28 2.55-3.50mm	1/4 .2500-.2498	1/4	SF-16-4	TW-2
		5/16	SF-16-5	
		*3/8	SF-16-6	
		*1/2	SF-16-8	
		*5/8	SF-16-10	
		*3/4	SF-16-12	

ID RANGE	OD	LENGTH	ANSI PART NO.	LOCK SCREW
.0135-.0291 #80-#70 .35-.70mm	5/16 .3125-.3123	*1/4	SF-20-4	LS-1 RC-01 RK-01 RK-10
		*5/16	SF-20-5	
		*3/8	SF-20-6	
		*1/2	SF-20-8	
		*3/4	SF-20-12	
		*5/16	SF-20-5	
.0292-.0519 #69-3/64 .75-1.30mm		*3/8	SF-20-6	
		*1/2	SF-20-8	
		*3/4	SF-20-12	
		*5/16	SF-20-5	
		*3/8	SF-20-6	
		*1/2	SF-20-8	
.0520-.0634 #55-1/16 1.35-1.60mm		*3/4	SF-20-12	
		5/16	SF-20-5	
		*3/8	SF-20-6	
		*1/2	SF-20-8	
		*3/4	SF-20-12	
		*1	SF-20-16	
.0635-.0934 #52-#43 1.65-2.35mm	5/16	SF-20-5		
	3/8	SF-20-6		
	*1/2	SF-20-8		
	*3/4	SF-20-12		
	*1-3/8	SF-20-22		
	*1	SF-20-16		
.0935-.1249 #42-#31 2.40-3.15mm	*1-3/8	SF-20-22		
	5/16	SF-20-5		
	3/8	SF-20-6		
	1/2	SF-20-8		
	5/8	SF-20-10		
	*3/4	SF-20-12		
.1250-.1935 1/8-#10 3.20-4.90mm	*1	SF-20-16		
	*1-3/8	SF-20-22		
	1/4	SF-24-4	TW-2	
	5/16	SF-24-5		
	3/8	SF-24-6		
	1/2	SF-24-8		
5/8	SF-24-10			
3/4	SF-24-12			
.1935-.2280 #10-#1 4.90-5.80mm	*1	SF-24-16		
	1/4	SF-28-4	TW-2	
	5/16	SF-28-5		
	3/8	SF-28-6		
	1/2	SF-28-8		
	5/8	SF-28-10		
3/4	SF-28-12			
.2340-.2900 A-L 5.90-7.40mm	7/16 .4375-.4373	*1	SF-28-16	

* **INFO+**: Counterbored, leaving correct drill-bearing length and clearance (see page 537 for bearing length).

CONTINUED ON NEXT PAGE

SLIP/FIXED RENEWABLE BUSHINGS

ID RANGE	OD	LENGTH	ANSI PART NO.	LOCK SCREW
.1405-.1889 #28-3/16 3.60-4.75mm	1/2 .5000-.4998	5/16	SF-32-5	LS-1 RC-01 RK-01 RK-10
		3/8	SF-32-6	
		1/2	SF-32-8	
		*3/4	SF-32-12	
		*1	SF-32-16	
		*1-3/8	SF-32-22	
		*1-1/2	SF-32-24	
		*1-3/4	SF-32-28	
.1890-.3438 #12-11/32 4.80-8.70mm	1/2 .5000-.4998	5/16	SF-32-5	
		3/8	SF-32-6	
		1/2	SF-32-8	
		3/4	SF-32-12	
		*1	SF-32-16	
		*1-3/8	SF-32-22	
		*1-1/2	SF-32-24	
		*1-3/4	SF-32-28	
.2950-.3438 M-11/32 7.50-8.80mm	9/16 .5625-.5623	1/4	SF-36-4	TW-2
		5/16	SF-36-5	
		3/8	SF-36-6	
		1/2	SF-36-8	
		5/8	SF-36-10	
		3/4	SF-36-12	
		1	SF-36-16	
.3480-.4375 S-7/16 8.90-11.00mm	5/8 .6250-.6248	3/8	SF-40-6	TW-2
		1/2	SF-40-8	
		5/8	SF-40-10	
		3/4	SF-40-12	
		1	SF-40-16	
		1-1/4	SF-40-20	
.2812-.5625 9/32-9/16 7.20-14.00mm	3/4 .7500-.7498	3/8	SF-48-6	LS-1 RC-01 RK-01 RK-11
		1/2	SF-48-8	
		3/4	SF-48-12	
		1	SF-48-16	
		1-3/8	SF-48-22	
		1-1/2	SF-48-24	
		1-3/4	SF-48-28	
		2-1/8	SF-48-34	
		*2-1/2	SF-48-40	
*3	SF-48-48			
.5469-.6562 35/64-21/32 13.50-16.50mm	7/8 .8750-.8748	1/2	SF-56-8	TW-7
		5/8	SF-56-10	
		3/4	SF-56-12	
		1	SF-56-16	
		1-1/4	SF-56-20	
		1-1/2	SF-56-24	
.4688-.7812 15/32-25/32 12.00-19.50mm	1 1.0000-.9998	1/2	SF-64-8	LS-2 RC-02 RK-02 RK-12
		3/4	SF-64-12	
		1	SF-64-16	
		1-3/8	SF-64-22	
		1-1/2	SF-64-24	
		1-3/4	SF-64-28	
		2-1/8	SF-64-34	
		2-1/2	SF-64-40	
3	SF-64-48			

* **INFO+**: Counterbored, leaving correct drill-bearing length and clearance (see page 537 for bearing length).

ID RANGE	OD	LENGTH	ANSI PART NO.	LOCK SCREW
.7188-1.0625 23/32-1-1/16 18.50-27.00mm	1-3/8 1.3750-1.3747	3/4	SF-88-12	LS-2 RC-02 RK-02 RK-12
		1	SF-88-16	
		1-3/8	SF-88-22	
		1-1/2	SF-88-24	
		1-3/4	SF-88-28	
		2-1/8	SF-88-34	
		2-1/2	SF-88-40	
		3	SF-88-48	
.9688-1.4062 31/32-1-13/32 25.00-35.00mm	1-3/4 1.7500-1.7497	3/4	SF-112-12	LS-3 RC-03 RK-03 RK-14
		1	SF-112-16	
		1-3/8	SF-112-22	
		1-1/2	SF-112-24	
		1-3/4	SF-112-28	
		2-1/8	SF-112-34	
		2-1/2	SF-112-40	
		3	SF-112-48	
1.3438-1.8750 1-11/32-1-7/8 35.00-47.00mm	2-1/4 2.2500-2.2496	3/4	SF-144-12	LS-3 RC-03 RK-03 RK-14
		1	SF-144-16	
		1-3/8	SF-144-22	
		1-1/2	SF-144-24	
		1-3/4	SF-144-28	
		2-1/8	SF-144-34	
		2-1/2	SF-144-40	
		3	SF-144-48	

For extended-range bushings (larger sizes) please see our web catalog.

SLIP/FIXED RENEWABLE BUSHINGS – CARBIDE



SFC

ID RANGE	OD	LENGTH	ANSI PART NO.	LOCK SCREW
.0520-.0934 #55-#43 1.35-2.35mm	5/16 .3125-.3123	5/16	SFC-20-5	LS-1 RC-01 RK-01 RK-10
		1/2	SFC-20-8	
		3/4	SFC-20-12	
		1	SFC-20-16	
.0935-.1562 #42-5/32 2.40-3.90mm	5/16 .3125-.3123	5/16	SFC-20-5	
		1/2	SFC-20-8	
		3/4	SFC-20-12	
		1	SFC-20-16	
.1406-.1889 9/64-3/16 3.60-4.75mm	1/2 .5000-.4998	5/16	SFC-32-5	LS-1 RC-01 RK-01 RK-10
		1/2	SFC-32-8	
		3/4	SFC-32-12	
		1	SFC-32-16	
.1890-.3438 #12-11/32 4.80-8.70mm	1/2 .5000-.4998	1-3/8	SFC-32-22	
		5/16	SFC-32-5	
		1/2	SFC-32-8	
		3/4	SFC-32-12	
.2812-.5312 9/32-17/32 7.20-13.00mm	3/4 .7500-.7498	1	SFC-32-16	LS-1 RC-01 RK-01 RK-10
		1-3/8	SFC-32-22	
		1/2	SFC-48-8	
		3/4	SFC-48-12	
.4688-.7812 15/32-25/32 12.00-19.50mm	1 1.0000-.9998	1	SFC-48-16	LS-2 RC-02 RK-02 RK-12
		1-3/8	SFC-48-22	
		1-3/4	SFC-64-28	
		1/2	SFC-64-8	
.7188-1.0312 23/32 - 1-1/32 18.50-27.00mm	1-3/8 1.3750-1.3747	3/4	SFC-64-12	LS-2 RC-02 RK-02 RK-12
		1	SFC-64-16	
		1-3/8	SFC-88-22	
		1-3/4	SFC-88-28	
.9688-1.4062 31/32 - 1-13/32 25.00-35.00mm	1-3/4 1.7500-1.7497	2-1/8	SFC-88-34	LS-3 RC-03 RK-03 RK-14
		2-1/2	SFC-88-40	
		1	SFC-112-16	
		1-3/8	SFC-112-22	
1.3438-1.7812 1-11/32- 1-25/32 35.00-45.00mm	2-1/4 2.2500-2.2496	1-3/4	SFC-112-28	LS-3 RC-03 RK-03 RK-14
		2-1/8	SFC-112-34	
		2-1/2	SFC-112-40	
		3	SFC-144-48	
1.3438-1.7812 1-11/32- 1-25/32 35.00-45.00mm	2-1/4 2.2500-2.2496	1	SFC-144-16	LS-3 RC-03 RK-03 RK-14
		1-3/8	SFC-144-22	
		1-3/4	SFC-144-28	
		2-1/8	SFC-144-34	
1.3438-1.7812 1-11/32- 1-25/32 35.00-45.00mm	2-1/4 2.2500-2.2496	2-1/2	SFC-144-40	LS-3 RC-03 RK-03 RK-14
		3	SFC-144-48	

Note: Due to manufacturing requirements, head dimensions of some carbide bushings may differ slightly from ANSI standards. Most carbide bushings have steel heads.

SLIP/FIXED RENEWABLE BUSHINGS – METRIC



SFM

ID RANGE	OD	LENGTH	ANSI PART NO.	LOCK SCREW	
.35-1.00mm	8mm 8.000-7.994mm	*10mm	SFM-8-10	LSM-1 LSM-2 RCM-1 RCM-2	
		*16mm	SFM-8-16		
10mm		SFM-8-10			
16mm		SFM-8-16			
10mm		SFM-8-10			
16mm		SFM-8-16			
1.01-1.80mm	8mm 8.000-7.994mm	12mm	SFM-10-12	LSM-3 LSM-4 RCM-3 RCM-4	
1.81-4.00mm		20mm	SFM-10-20		
		25mm	SFM-10-25		
4.01-6.00mm		10mm 10.000-9.994mm	12mm		SFM-12-12
			20mm		SFM-12-20
			25mm		SFM-12-25
6.01-8.00mm	12mm 12.000-11.992mm	16mm	SFM-15-16	LSM-5 LSM-6 RCM-5 RCM-6	
		28mm	SFM-15-28		
		36mm	SFM-15-36		
8.01-10.00mm	15mm 15.000-14.992mm	16mm	SFM-18-16	LSM-7 LSM-8 RCM-7 RCM-8	
		28mm	SFM-18-28		
		36mm	SFM-18-36		
10.01-12.00mm	18mm 18.000-17.992mm	20mm	SFM-22-20	LSM-7 LSM-8 RCM-7 RCM-8	
		36mm	SFM-22-36		
		45mm	SFM-22-45		
12.01-15.00mm	22mm 22.000-21.991mm	20mm	SFM-26-20	LSM-7 LSM-8 RCM-7 RCM-8	
		36mm	SFM-26-36		
		45mm	SFM-26-45		
15.01-18.00mm	26mm 26.000-25.991mm	25mm	SFM-30-25	LSM-7 LSM-8 RCM-7 RCM-8	
		45mm	SFM-30-45		
		56mm	SFM-30-56		
18.01-22.00mm	30mm 30.000-29.991mm	25mm	SFM-35-25	LSM-7 LSM-8 RCM-7 RCM-8	
		45mm	SFM-35-45		
		56mm	SFM-35-56		
22.01-26.00mm	35mm 35.000-34.989mm	30mm	SFM-42-30	LSM-7 LSM-8 RCM-7 RCM-8	
		56mm	SFM-42-56		
		67mm	SFM-42-67		
26.01-30.00mm	42mm 42.000-41.989mm	30mm	SFM-48-30	LSM-7 LSM-8 RCM-7 RCM-8	
		56mm	SFM-48-56		
		67mm	SFM-48-67		
30.01-35.00mm	48mm 48.000-47.989mm	30mm	SFM-55-30	LSM-7 LSM-8 RCM-7 RCM-8	
		56mm	SFM-55-56		
		67mm	SFM-55-67		
35.01-42.00mm	55mm 55.000-54.987mm	35mm	SFM-62-35	LSM-7 LSM-8 RCM-7 RCM-8	
		67mm	SFM-62-67		
		78mm	SFM-62-78		
42.01-48.00mm	62mm 62.000-61.987mm	35mm	SFM-62-35	LSM-7 LSM-8 RCM-7 RCM-8	
		67mm	SFM-62-67		
		78mm	SFM-62-78		

ID RANGE (G6)	OD (h5)	LENGTH	ANSI PART NO.	LOCK SCREW
48.01-55.00mm	70mm 70.000-69.987mm	35mm	SFM-70-35	LSM-7 LSM-8 RCM-7 RCM-8
		67mm	SFM-70-67	
		78mm	SFM-70-78	
55.01-62.00mm	78mm 78.000-77.987mm	40mm	SFM-78-40	LSM-7 LSM-8 RCM-7 RCM-8
		78mm	SFM-78-78	
		105mm	SFM-78-105	
62.01-70.00mm	85mm 85.000-84.985mm	40mm	SFM-85-40	LSM-7 LSM-8 RCM-7 RCM-8
		78mm	SFM-85-78	
		105mm	SFM-85-105	
70.01-78.00mm	95mm 95.000-94.985mm	45mm	SFM-95-45	LSM-7 LSM-8 RCM-7 RCM-8
		89mm	SFM-95-89	
		112mm	SFM-95-112	
78.01-85.00mm	105mm 105.000-104.985mm	45mm	SFM-105-45	LSM-7 LSM-8 RCM-7 RCM-8
		89mm	SFM-105-89	
		112mm	SFM-105-112	

* Small metric drill sizes through .80mm are counterbored 1.00mm diameter, with 3mm drill-bearing length.

FLAT MILLED RENEWABLE BUSHINGS

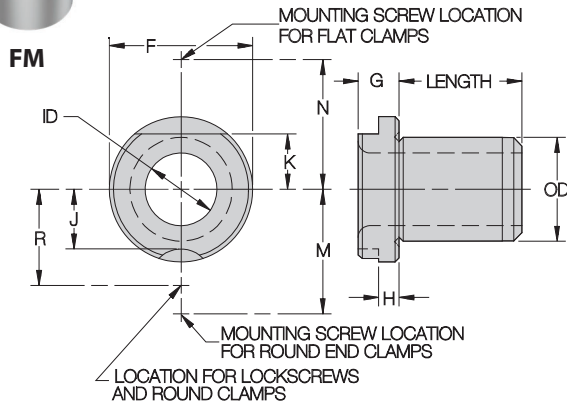

BODY OD	F	G	H	J	K	M	N	R	FLAT CLAMP	LOCK SCREW
5/16	35/64			11/64	11/64	5/8	11/16	1/2	FC-01 FC-10	LS-1
1/2	51/64	1/4	1/8	19/64	17/64	3/4	25/32	5/8		
3/4	1-3/64			27/64	25/64	7/8	57/64	3/4	FC-02 FC-12	LS-2
1	1-27/64	3/8	3/16	19/32	1/2	1-7/64	1-9/64	59/64		
1-3/8	1-51/64			25/32	11/16	1-19/54	1-21/64	1-7/64	FC-03 FC-14 FC-15	LS-3
1-3/4	2-19/64	3/8	3/16	1	7/8	1-41/64	1-33/64	1-25/64		
2-1/4	2-51/64			1-1/4	1-1/8	1-57/64	1-49/64	1-41/64		

APPLICATIONS:

Replaceable bushing used for extra resistance to rotational forces under harsh conditions. This bushing, generally used with a liner, has a milled locking flat to allow fastening securely with a flat clamp. FM bushings also have a standard recess on the other side to allow using a lock screw instead.

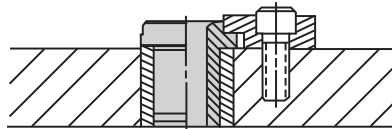

ORDERING EXAMPLES:

FM-20-16-.1250	Standard inch Bushing, inch ID
FM-20-16-.1772	Standard inch Bushing, mm ID (.1772 = 4.50mm)
FM-20-16-.1250 REAMER	Reamer Tolerance on ID
FM-20-16-.1250 NCB	No counterbore on long bushings marked with * (no counterbore is standard on all other bushings)
FMC-20-16-.1250	Carbide Bushing

Standard prices apply only to bushings with a standard-drill-size ID within the stated ID range. See catalog back cover for standard drill sizes and their decimal equivalents. For prices on non-standard ID sizes, including reamer-tolerance and tap-guide bushings, please contact factory.

STANDARD ID TOLERANCES:

From #80 to 1/4"	+0.001/+0.0004	From .35 to 3mm	+0.002/+0.008mm
Over 1/4 to 3/4"	+0.001/+0.0005	Over 3 to 6mm	+0.004/+0.012mm
Over 3/4 to 1-1/2"	+0.002/+0.0006	Over 6 to 10mm	+0.005/+0.014mm
Over 1-1/2 to 2-3/4"	+0.003/+0.0007	Over 10 to 18mm	+0.006/+0.017mm
		Over 18 to 30mm	+0.007/+0.020mm
		Over 30 to 50mm	+0.009/+0.025mm (G6 tolerance)

REAMER ID TOLERANCES:

From #60 to 1/4"	+0.005/+0.0008	From 1 to 3mm	+0.006/+0.012mm
Over 1/4 to 1"	+0.006/+0.0010	Over 3 to 6mm	+0.010/+0.018mm
Over 1" to 1-1/2"	+0.008/+0.0012	Over 6 to 10mm	+0.013/+0.022mm
		Over 10 to 18mm	+0.016/+0.027mm
		Over 18 to 30mm	+0.020/+0.033mm (F6 tolerance)

ID RANGE	OD	LENGTH	ANSI PART NO.	CLAMP
.0135-.0291 #80-#70 .35-.70mm	5/16 .3125-.3123	*1/4	FM-20-4	FC-01 FC-10 LS-1 RC-01 RK-01 RK-10
		*5/16	FM-20-5	
		*3/8	FM-20-6	
		*1/2	FM-20-8	
*3/4		FM-20-12		
.0292-.0519 #69-3/64 .75-1.30mm		*5/16	FM-20-5	
		*3/8	FM-20-6	
		*1/2	FM-20-8	
		*3/4	FM-20-12	
.0520-.0634 #55-1/16 1.35-1.60mm		*5/16	FM-20-5	
		*3/8	FM-20-6	
		*1/2	FM-20-8	
	*3/4	FM-20-12		
.0635-.0934 #52-#43 1.65-2.35mm	5/16	FM-20-5		
	*3/8	FM-20-6		
	*1/2	FM-20-8		
	*3/4	FM-20-12		
.0935-.1249 #42-#31 2.40-3.15mm	*1	FM-20-16		
	5/16	FM-20-5		
	3/8	FM-20-6		
	*1/2	FM-20-8		
.1250-.1935 1/8-#10 3.20-4.90mm	*3/4	FM-20-12		
	*1	FM-20-16		
	*1-3/8	FM-20-22		
	5/16	FM-20-5		
	3/8	FM-20-6		
	1/2	FM-20-8		
	5/8	FM-20-10		

* **INFO+:** Counterbored, leaving correct drill-bearing length and clearance.

CONTINUED ON NEXT PAGE

FLAT MILLED RENEWABLE BUSHINGS

ID RANGE	OD	LENGTH	ANSI PART NO.	CLAMP
.1405-1889 #28-3/16 3.60-4.75mm	1/2 .5000-.4998	5/16	FM-32-5	FC-01 FC-10 LS-1 RC-01 RK-01 RK-10
		3/8	FM-32-6	
		1/2	FM-32-8	
		*3/4	FM-32-12	
		*1	FM-32-16	
		*1-3/8	FM-32-22	
		*1-1/2	FM-32-24	
		*1-3/4	FM-32-28	
		5/16	FM-32-5	
		3/8	FM-32-6	
.1890-3438 #12-11/32 4.80-8.70mm	1/2 .5000-.4998	1/2	FM-32-8	
		3/4	FM-32-12	
		*1	FM-32-16	
		*1-3/8	FM-32-22	
		*1-1/2	FM-32-24	
		*1-3/4	FM-32-28	
		*2-1/8	FM-32-34	
		3/8	FM-48-6	FC-01 FC-11 LS-1 RC-01 RK-01 RK-11
		1/2	FM-48-8	
		3/4	FM-48-12	
1	FM-48-16			
1-3/8	FM-48-22			
1-1/2	FM-48-24			
1-3/4	FM-48-28			
2-1/8	FM-48-34			
*2-1/2	FM-48-40			
*3	FM-48-48			
.4688-7812 15/32-25/32 12.00-19.50mm	1 1.0000-.9998	1/2	FM-64-8	FC-02 FC-12 LS-2 RC-02 RK-02 RK-12
		3/4	FM-64-12	
		1	FM-64-16	
		1-3/8	FM-64-22	
		1-1/2	FM-64-24	
		1-3/4	FM-64-28	
		2-1/8	FM-64-34	
		2-1/2	FM-64-40	
		3	FM-64-48	
		.7188-1.0625 23/32 – 1-1/16 18.50-27.00mm	1-3/8 1.3750-1.3747	
1	FM-88-16			
1-3/8	FM-88-22			
1-1/2	FM-88-24			
1-3/4	FM-88-28			
2-1/8	FM-88-34			
2-1/2	FM-88-40			
3	FM-88-48			

* **INFO+**: Counterbored, leaving correct drill-bearing length and clearance (see page 551 for bearing length).

ID RANGE	OD	LENGTH	ANSI PART NO.	CLAMP
.9688-1.4062 31/32 – 1-13/32 25.00-35.00mm	1-3/4 1.7500-1.7497	3/4	FM-112-12	FC-03 FC-14 FC-15 LS-3 RC-03 RK-03 RK-14
		1	FM-112-16	
		1-3/8	FM-112-22	
		1-1/2	FM-112-24	
		1-3/4	FM-112-28	
		2-1/8	FM-112-34	
		2-1/2	FM-112-40	
		3	FM-112-48	
1.3438-1.8750 1-11/32 – 1-7/8 35.00-47.00mm	2-1/4 2.2500-2.2496	3/4	FM-144-12	FC-03 FC-14 FC-15 LS-3 RC-03 RK-03 RK-14
		1	FM-144-16	
		1-3/8	FM-144-22	
		1-1/2	FM-144-24	
		1-3/4	FM-144-28	
		2-1/8	FM-144-34	
		2-1/2	FM-144-40	
		3	FM-144-48	

For extended-range bushings (larger sizes) please see our web catalog.



Follow Us



LINER BUSHINGS

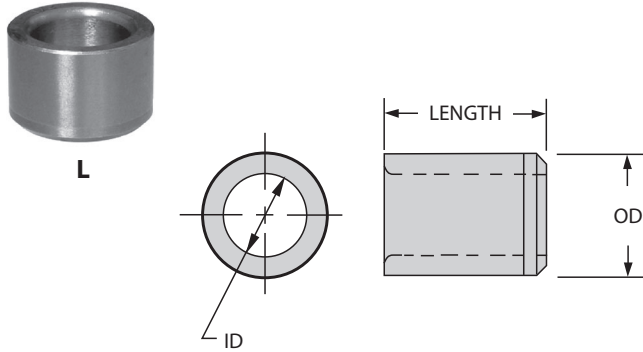

APPLICATIONS:

Liners are permanent bushings used to hold renewable drill bushings. The liner's ID has a precise sliding fit with the renewable bushing's OD. The hardened liner accurately locates the renewable bushing and protects the jig plate from wear caused by frequent bushing replacement. Note: Metric liner bushings are the same as metric press-fit bushings.

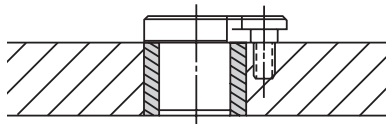

ORDERING EXAMPLES:

L-32-16 Standard inch liner bushing
 L-32-16U Unground OD
 L-40-16-24 Standard inch liner bushing with a choice of ID in that OD size
 PM-18-25-12.00 Standard metric liner bushing (same as metric press-fit type)

STANDARD LINER ID TOLERANCES:

3/16 to 3/8"	+0.001/+0.004	8 to 10mm	+0.005/+0.014mm
7/16 to 5/8"	+0.002/+0.005	12 to 18mm	+0.006/+0.017mm
3/4"	+0.003/+0.006	22 to 30mm	+0.007/+0.020mm
7/8 to 1"	+0.004/+0.007	35 to 48mm	+0.009/+0.025mm
1-3/8"	+0.006/+0.010	55 to 78mm	+0.010/+0.029mm
1-3/4"	+0.008/+0.012	85 to 105mm	+0.012/+0.034mm
2-1/4"	+0.010/+0.015		(G6 tolerance)

ID	OD	LENGTH	ANSI PART NO.
3/16	5/16 .3141-.3138 (.327-.322 UNG)	1/4	L-20-4
		5/16	L-20-5
		3/8	L-20-6
		1/2	L-20-8
		5/8	L-20-10
		3/4	L-20-12
1/4	7/16 .4392-.4389 (.453-.448 UNG)	1/4	L-28-4
		5/16	L-28-5
		3/8	L-28-6
		1/2	L-28-8
		5/8	L-28-10
		3/4	L-28-12

ID	OD	LENGTH	ANSI PART NO.
5/16	1/2 .5017-.5014 (.520-.515 UNG)	1/4	L-32-4
		5/16	L-32-5
		3/8	L-32-6
		1/2	L-32-8
		5/8	L-32-10
		3/4	L-32-12
		1	L-32-16
	9/16 .5642-.5639 (.582-.577 UNG)	1-3/8	L-32-22
		1/4	L-36-4
		5/16	L-36-5
		3/8	L-36-6
		1/2	L-36-8
		5/8	L-36-10
		3/4	L-36-12
3/8	5/8 .6267-.6264 (.645-.640 UNG)	1	L-36-16
		1/4	L-40-4-24
		5/16	L-40-5-24
		3/8	L-40-6-24
		1/2	L-40-8-24
		5/8	L-40-10-24
		3/4	L-40-12-24
		1	L-40-16-24
		1/4	L-40-4-28
		5/16	L-40-5-28
		3/8	L-40-6-28
		1/2	L-40-8-28
		5/8	L-40-10-28
		3/4	L-40-12-28
1	L-40-16-28		
1/2	3/4 .7518-.7515 (.770-.765 UNG)	5/16	L-48-5
		3/8	L-48-6
		1/2	L-48-8
		3/4	L-48-12
		1	L-48-16
		1-3/8	L-48-22
		1-1/2	L-48-24
		1-3/4	L-48-28
		2-1/8	L-48-34
		9/16	7/8 .8768-.8765 (.895-.890 UNG)
3/8	L-56-6-36		
1/2	L-56-8-36		
5/8	L-56-10-36		
3/4	L-56-12-36		
1	L-56-16-36		
1-1/4	L-56-20-36		
5/16	L-56-5-40		
3/8	L-56-6-40		
1/2	L-56-8-40		
5/8	L-56-10-40		
3/4	L-56-12-40		
1	L-56-16-40		
1-1/4	L-56-20-40		
5/8			

CONTINUED ON NEXT PAGE

LINER BUSHINGS

ID	OD	LENGTH	ANSI PART NO.
3/4	1 1.0018-1.0015 (1.020-1.015 UNG)	1/2	L-64-8
		3/4	L-64-12
		1	L-64-16
		1-3/8	L-64-22
		1-1/2	L-64-24
		1-3/4	L-64-28
		2-1/8	L-64-34
		2-1/2	L-64-40
		3	L-64-48
7/8	1-1/4 1.2520-1.2517 (1.270-1.265 UNG)	1/2	L-80-8
		5/8	L-80-10
		3/4	L-80-12
		1	L-80-16
		1-1/4	L-80-20
		1-1/2	L-80-24
1	1-3/8 1.3772-1.3768 (1.395-1.390 UNG)	1/2	L-88-8
		3/4	L-88-12
		1	L-88-16
		1-3/8	L-88-22
		1-1/2	L-88-24
		1-3/4	L-88-28
		2-1/8	L-88-34
		2-1/2	L-88-40
		3	L-88-48
1-3/8	1-3/4 1.7523-1.7519 (1.770-1.765 UNG)	3/4	L-112-12
		1	L-112-16
		1-3/8	L-112-22
		1-1/2	L-112-24
		1-3/4	L-112-28
		2-1/8	L-112-34
		2-1/2	L-112-40
		3	L-112-48
		1-3/4	2-1/4 2.2525-2.2521 (2.270-2.265 UNG)
1	L-144-16		
1-3/8	L-144-22		
1-1/2	L-144-24		
1-3/4	L-144-28		
2-1/8	L-144-34		
2-1/2	L-144-40		
3	L-144-48		
2-1/4	2-1/4 2.2525-2.2521 (2.270-2.265 UNG)		
		1	L-176-16
		1-3/8	L-176-22
		1-1/2	L-176-24
		1-3/4	L-176-28
		2-1/8	L-176-34
		2-1/2	L-176-40
		3	L-176-48

For extended-range bushings (larger sizes) please see our web catalog.

LINER BUSHINGS – METRIC



PM

ID (G6)	OD (s6)	LENGTH	ANSI PART NO.
8mm	12mm 12.039-12.028mm	10mm	PM-12-10-8.00
		16mm	PM-12-16-8.00
10mm	15mm 15.039-15.028mm	12mm	PM-15-12-10.00
		20mm	PM-15-20-10.00
		25mm	PM-15-25-10.00
12mm	18mm 18.039-18.028mm	12mm	PM-18-12-12.00
		20mm	PM-18-20-12.00
		25mm	PM-18-25-12.00
15mm	22mm 22.048-22.035mm	16mm	PM-22-16-15.00
		28mm	PM-22-28-15.00
		36mm	PM-22-36-15.00
18mm	26mm 26.048-26.035mm	16mm	PM-26-16-18.00
		28mm	PM-26-28-18.00
		36mm	PM-26-36-18.00
22mm	30mm 30.048-30.035mm	20mm	PM-30-20-22.00
		36mm	PM-30-36-22.00
		45mm	PM-30-45-22.00
26mm	35mm 35.059-35.043mm	20mm	PM-35-20-26.00
		36mm	PM-35-36-26.00
		45mm	PM-35-45-26.00
30mm	42mm 42.059-42.043mm	25mm	PM-42-25-30.00
		45mm	PM-42-45-30.00
		56mm	PM-42-56-30.00
35mm	48mm 48.059-48.043mm	25mm	PM-48-25-35.00
		45mm	PM-48-45-35.00
		56mm	PM-48-56-35.00
42mm	55mm 55.072-55.053mm	30mm	PM-55-30-42.00
		56mm	PM-55-56-42.00
		67mm	PM-55-67-42.00
48mm	62mm 62.072-62.053mm	30mm	PM-62-30-48.00
		56mm	PM-62-56-48.00
		67mm	PM-62-67-48.00
55mm	70mm 70.078-70.059mm	30mm	PM-70-30-55.00
		56mm	PM-70-56-55.00
		67mm	PM-70-67-55.00
62mm	78mm 78.078-78.059mm	35mm	PM-78-35-62.00
		67mm	PM-78-67-62.00
		78mm	PM-78-78-62.00

ID (G6)	OD (s6)	LENGTH	ANSI PART NO.
70mm	85mm 85.093-85.071mm	35mm	PM-85-35-70.00
		67mm	PM-85-67-70.00
		78mm	PM-85-78-70.00
78mm	95mm 95.093-95.071mm	40mm	PM-95-40-78.00
		78mm	PM-95-78-78.00
		105mm	PM-95-105-78.00
85mm	105mm 105.101-105.079mm	40mm	PM-105-40-85.00
		78mm	PM-105-78-85.00
		105mm	PM-105-105-85.00
95mm	115mm 115.101-115.079mm	45mm	PM-115-45-95.00
		89mm	PM-115-89-95.00
		112mm	PM-115-112-95.00
105mm	125mm 125.117-125.092mm	45mm	PM-125-45-105.00
		89mm	PM-125-89-105.00
		112mm	PM-125-112-105.00

Note: Metric liner bushings are the same as metric press-fit bushings.

HEAD LINER BUSHINGS



HL

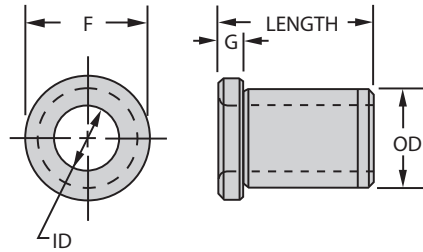

INCH

BODY OD	F DIA	G
1/2	5/8	3/32
3/4	7/8	3/32
1	1-1/8	1/8
1-3/8	1-1/2	1/8
1-3/4	1-7/8	3/16
2-1/4	2-3/8	3/16
2-3/4	2-7/8	3/16

METRIC

BODY OD	F DIA	G
12mm	15mm	3mm
15mm	18mm	3mm
18mm	22mm	4mm
22mm	26mm	4mm
26mm	30mm	4mm
30mm	34mm	5mm
35mm	39mm	5mm
42mm	46mm	5mm
48mm	52mm	5mm
55mm	59mm	5mm
62mm	66mm	6mm
70mm	74mm	6mm
78mm	82mm	6mm
85mm	90mm	6mm
95mm	100mm	6mm
105mm	110mm	6mm
115mm	120mm	6mm
125mm	130mm	6mm

APPLICATIONS:

Similar to an L bushing, but with a head to resist heavy axial loads. Head liners are permanent bushings used to hold renewable drill bushings. The head liner's ID has a precise sliding fit with the renewable bushing's OD. The hardened head liner accurately locates the renewable bushing and protects the jig plate from wear caused by frequent bushing replacement. Note: The "length" listed for a head liner refers to its overall length, not its length under the head. Metric head-liner bushings are the same as metric head-press-fit bushings.

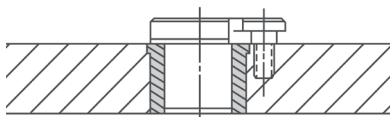

ORDERING EXAMPLES:

HL-32-16 Standard inch liner bushing
 HL-32-16U Unground OD
 HM-18-25-12.00 Standard metric liner bushing (same as metric press-fit type)

STANDARD LINER ID TOLERANCES:

5/16"	+0.001/+0.004	8 to 10mm	+0.05/+0.14mm
1/2"	+0.002/+0.005	12 to 18mm	+0.06/+0.17mm
3/4"	+0.003/+0.006	22 to 30mm	+0.07/+0.20mm
1"	+0.004/+0.007	35 to 48mm	+0.09/+0.25mm
1-3/8"	+0.006/+0.010	55 to 78mm	+0.10/+0.29mm
1-3/4"	+0.008/+0.012	85 to 105mm	+0.12/+0.34mm
2-1/4"	+0.010/+0.015	(G6 tolerance)	

ID RANGE	OD	LENGTH	ANSI PART NO.		
5/16	1/2 .5017-.5014 (.520-.515 UNG)	5/16	HL-32-5		
		3/8	HL-32-6		
		1/2	HL-32-8		
		3/4	HL-32-12		
		1	HL-32-16		
1/2	3/4 .7518-.7515 (.770-.765 UNG)	1-3/8	HL-32-22		
		5/16	HL-48-5		
		3/8	HL-48-6		
		1/2	HL-48-8		
		3/4	HL-48-12		
		1	HL-48-16		
		1-3/8	HL-48-22		
		1-1/2	HL-48-24		
		1-3/4	HL-48-28		
		2-1/8	HL-48-34		
3/4	1 1.0018-1.0015 (1.020-1.015 UNG)	1/2	HL-64-8		
		3/4	HL-64-12		
		1	HL-64-16		
		1-3/8	HL-64-22		
		1-1/2	HL-64-24		
		1-3/4	HL-64-28		
		2-1/8	HL-64-34		
		2-1/2	HL-64-40		
		3	HL-64-48		
		1	1-3/8 1.3772-1.3768 (1.395-1.390 UNG)	1/2	HL-88-8
3/4	HL-88-12				
1	HL-88-16				
1-3/8	HL-88-22				
1-1/2	HL-88-24				
1-3/4	HL-88-28				
2-1/8	HL-88-34				
2-1/2	HL-88-40				
3	HL-88-48				
1-3/8	1-3/4 1.7523-1.7519 (1.770-1.765 UNG)			3/4	HL-112-12
		1	HL-112-16		
		1-3/8	HL-112-22		
		1-1/2	HL-112-24		
		1-3/4	HL-112-28		
		2-1/8	HL-112-34		
		2-1/2	HL-112-40		
		3	HL-112-48		
		1-3/4	2-1/4 2.2525-2.2521 (2.270-2.265 UNG)	3/4	HL-144-12
				1	HL-144-16
1-3/8	HL-144-22				
1-1/2	HL-144-24				
1-3/4	HL-144-28				
2-1/8	HL-144-34				
2-1/2	HL-144-40				
3	HL-144-48				
2-1/4	2-3/4 2.7526-2.7522 (2.770-2.765 UNG)			3/4	HL-176-12
				1	HL-176-16
		1-3/8	HL-176-22		
		1-1/2	HL-176-24		
		1-3/4	HL-176-28		
		2-1/8	HL-176-34		
		2-1/2	HL-176-40		
		3	HL-176-48		

HEAD LINER BUSHINGS – METRIC



HM

ID (G6)	OD (s6)	LENGTH	ANSI PART NO.
8mm	12mm 12.039-12.028mm	10mm	HM-12-10-8.00
		16mm	HM-12-16-8.00
10mm	15mm 15.039-15.028mm	12mm	HM-15-12-10.00
		20mm	HM-15-20-10.00
		25mm	HM-15-25-10.00
12mm	18mm 18.039-18.028mm	12mm	HM-18-12-12.00
		20mm	HM-18-20-12.00
		25mm	HM-18-25-12.00
15mm	22mm 22.048-22.035mm	16mm	HM-22-16-15.00
		28mm	HM-22-28-15.00
		36mm	HM-22-36-15.00
18mm	26mm 26.048-26.035mm	16mm	HM-26-16-18.00
		28mm	HM-26-28-18.00
		36mm	HM-26-36-18.00
22mm	30mm 30.048-30.035mm	20mm	HM-30-20-22.00
		36mm	HM-30-36-22.00
		45mm	HM-30-45-22.00
26mm	35mm 35.059-35.043mm	20mm	HM-35-20-26.00
		36mm	HM-35-36-26.00
		45mm	HM-35-45-26.00
30mm	42mm 42.059-42.043mm	25mm	HM-42-25-30.00
		45mm	HM-42-45-30.00
		56mm	HM-42-56-30.00
35mm	48mm 48.059-48.043mm	25mm	HM-48-25-35.00
		45mm	HM-48-45-35.00
		56mm	HM-48-56-35.00
42mm	55mm 55.072-55.053mm	30mm	HM-55-30-42.00
		56mm	HM-55-56-42.00
		67mm	HM-55-67-42.00
48mm	62mm 62.072-62.053mm	30mm	HM-62-30-48.00
		56mm	HM-62-56-48.00
		67mm	HM-62-67-48.00
55mm	70mm 70.078-70.059mm	30mm	HM-70-30-55.00
		56mm	HM-70-56-55.00
		67mm	HM-70-67-55.00
62mm	78mm 78.078-78.059mm	35mm	HM-78-35-62.00
		67mm	HM-78-67-62.00
		78mm	HM-78-78-62.00

ID (G6)	OD (s6)	LENGTH	ANSI PART NO.
70mm	85mm 85.093-85.071mm	35mm	HM-85-35-70.00
		67mm	HM-85-67-70.00
		78mm	HM-85-78-70.00
78mm	95mm 95.093-95.071mm	40mm	HM-95-40-78.00
		78mm	HM-95-78-78.00
		105mm	HM-95-105-78.00
85mm	105mm 105.101-105.079mm	40mm	HM-105-40-85.00
		78mm	HM-105-78-85.00
		105mm	HM-105-105-85.00
95mm	115mm 115.101-115.079mm	45mm	HM-115-45-95.00
		89mm	HM-115-89-95.00
		112mm	HM-115-112-95.00
105mm	125mm 125.117-125.092mm	45mm	HM-125-45-105.00
		89mm	HM-125-89-105.00
		112mm	HM-125-112-105.00

Note: Metric head-liner bushings are the same as metric head-press-fit bushings.

UN-A-LOK™ LINER BUSHINGS



UL
ULM

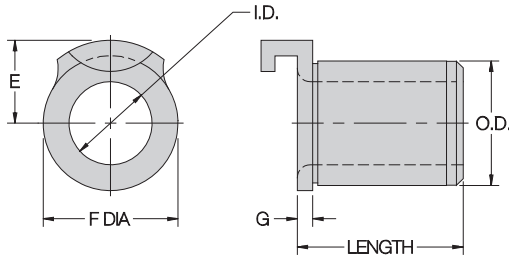

INCH

BODY OD	E	F DIA	G
5/16	1/4	.365	3/32
1/2	3/8	9/16	3/32
3/4	1/2	13/16	3/32
1	21/32	1-1/16	1/8
1-3/8	7/8	1-7/16	1/8

METRIC

BODY OD	E	F DIA	G
12mm	9.5mm	15mm	3mm
15mm	11mm	18mm	3mm
18mm	13mm	22mm	4mm
22mm	15.5mm	26mm	4mm
26mm	17.5mm	30mm	4mm

APPLICATIONS:

Similar to an HL head liner, but incorporating a special locking tab that eliminates the need for a lockscrew. Un-A-Lok™ liners are permanent bushings used to hold SF renewable drill bushings (on the “slip” side only, not the “fixed” side). Although slightly more expensive than a head liner plus a lockscrew, installation time is dramatically reduced. **Patent no. 3,015,242 and 3,099,079.**

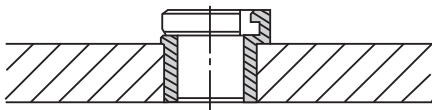

ORDERING EXAMPLES:

UL-20-5	Standard inch liner bushing
UL-20-5U	Unground OD
ULM-12-10	Standard metric liner bushing

STANDARD LINER ID TOLERANCES:

3/16 to 5/16"	+0.001/+0.004	8 to 10mm	+0.05/+0.14mm
1/2"	+0.002/+0.005	12 to 18mm	+0.06/+0.17mm
3/4"	+0.003/+0.006		(G6 tolerance)
1"	+0.004/+0.007		

INCH

ID	OD	LENGTH	ANSI PART NO.
3/16	5/16 .3141-.3138 (.327-.322 UNG)	5/16	UL-20-5
		3/8	UL-20-6
		1/2	UL-20-8
		3/4	UL-20-12
5/16	1/2 .5017-.5014 (.520-.515 UNG)	3/8	UL-32-6
		1/2	UL-32-8
		3/4	UL-32-12
1/2	3/4 .7518-.7515 (.770-.765 UNG)	1/2	UL-48-8
		3/4	UL-48-12
		1	UL-48-16
		1	UL-48-22
3/4	1 1.0018-1.0015 (1.020-1.015 UNG)	1/2	UL-64-8
		3/4	UL-64-12
		1	UL-64-16
1	1-3/8 1.3772-1.3768 (1.395-1.390 UNG)	1/2	UL-88-8
		3/4	UL-88-12
		1	UL-88-16
		1-3/8	UL-88-22

METRIC

ID (G6)	OD (s6)	LENGTH	PART NO.
8mm	12mm 12.039-12.028mm	10mm	ULM-12-10-8.00
		16mm	ULM-12-16-8.00
10mm	15mm 15.039-15.028mm	12mm	ULM-15-12-10.00
		20mm	ULM-15-20-10.00
		25mm	ULM-15-25-10.00
12mm	18mm 18.039-18.028mm	12mm	ULM-18-12-12.00
		20mm	ULM-18-20-12.00
		25mm	ULM-18-25-12.00
15mm	22mm 22.048-22.035mm	16mm	ULM-22-16-15.00
		28mm	ULM-22-28-15.00
		36mm	ULM-22-36-15.00
18mm	26mm 26.048-26.035mm	16mm	ULM-26-16-18.00
		28mm	ULM-26-28-18.00
		36mm	ULM-26-36-18.00

BUSHING HANDLES

QUICK-CHANGE HANDLE: ALUMINUM WITH 1144 STEEL UN-A-LOK LINER
PERMANENT HANDLE: MILD STEEL



Quick-Change Bushing Handle

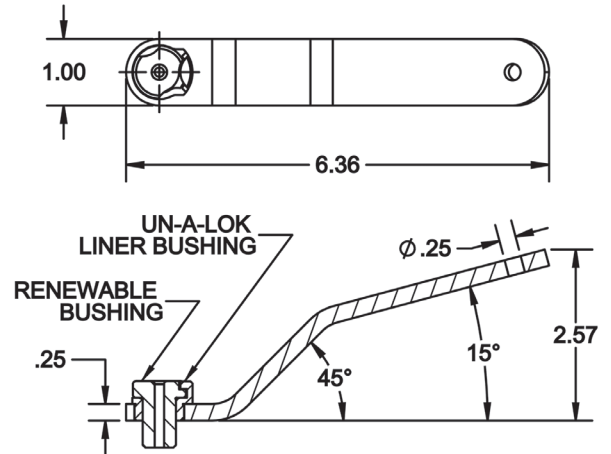

Quick-Change Bushing Handles are ready to hold any Slip/Fixed Renewable Drill Bushing in a choice of three OD sizes – 3/16, 5/16, or 1/2". These comfortable, high-quality handles provide convenient handling and extra support when using a portable drill motor. A Un-A-Lok liner bushing permanently installed in the handle provides excellent wear resistance and quick bushing changes. The handle is provided with a hole in the end for cable attachment.

PART NO.	SF BUSHING OD
CL-12-BHQC	3/16
CL-20-BHQC	5/16
CL-32-BHQC	1/2



Permanent Bushing Handle

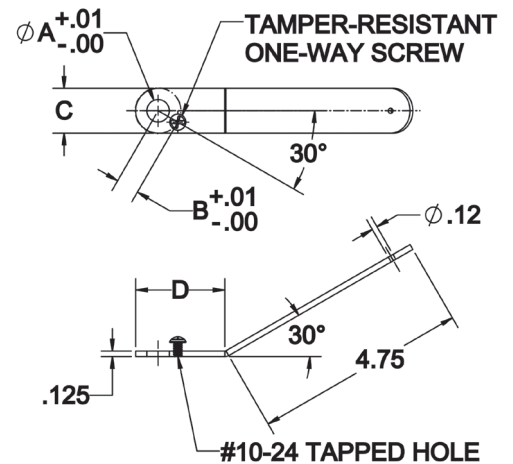

Permanent Bushing Handles are designed for one-time installation of a Slip/Fixed Bushing directly into the steel handle, where it is fastened with a tamper-resistant one-way screw to create a permanent assembly.

PART NO.	SF BUSHING OD	A DIA	B	C	D
CL-20-BH	5/16	.313	.383	1	1.12
CL-32-BH	1/2	.501	.508	1	1.12

LOCKSCREWS AND CLAMPS

LOCKSCREWS

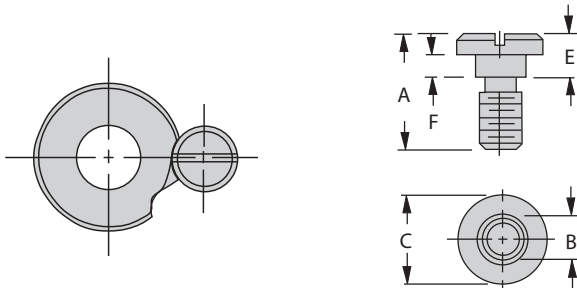

The most popular locking device for renewable drill bushings. Use on either the "slip" or "fixed" side of a slip-fixed bushing. Simple, strong, compact, and economical.

STANDARD MOUNTING (INCH)

PART NO. (PACK OF 5)	A	B DIA	C DIA	E	F	THREAD
LS-0-PACKOF5	7/16	3/16	5/16	3/16	.105/.100	#8-32
LS-1-PACKOF5	5/8	3/8	5/8	1/4	.138/.132	5/16-18
LS-2-PACKOF5	7/8			3/8	.200/.194	
LS-3-PACKOF5	1	7/16	3/4	3/8	.200/.194	3/8-16
LS-4-PACKOF5*	1-1/16			7/16	.231/.225	
LS-5-PACKOF5*	1-1/8			1/2	.263/.257	

STANDARD MOUNTING - THINWALL (INCH)

PART NO.	A	B DIA	C DIA	E	F	THREAD
TW-1-PACKOF5	7/16	3/16	5/16	3/16	.105/.100	#8-32
TW-2-PACKOF5	1/2	1/4	3/8	1/4	.138/.132	#10-32
TW-3-PACKOF5	11/16		7/16	3/8	.200/.194	
TW-4-PACKOF5	7/8	3/8	9/16	1/2	.263/.257	5/16-18
TW-5-PACKOF5	1	3/8	5/8	5/8	.325/.319	
TW-7-PACKOF5	3/4			3/8	.200/.194	

STANDARD MOUNTING (METRIC)

PART NO.	A	B DIA	C DIA	E	F	THREAD
LSM-1-PACKOF5	15mm	7.5mm	13mm	6mm	3.3mm	M5
LSM-3-PACKOF5	18mm	9.5mm	16mm	8mm	4.3mm	M6
LSM-5-PACKOF5	22mm	12mm	20mm	10mm	5.8mm	M8
LSM-7-PACKOF5	32mm	15mm	24mm	12mm	7.3mm	M10

PROJECTED MOUNTING (METRIC)

PART NO.	A	B DIA	C DIA	E	F	THREAD
LSM-2-PACKOF5	18mm	7.5mm	13mm	9mm	6.3mm	M5
LSM-4-PACKOF5	22mm	9.5mm	16mm	12mm	8.3mm	M6
LSM-6-PACKOF5	27mm	12mm	20mm	15mm	10.8mm	M8
LSM-8-PACKOF5	38mm	15mm	24mm	18mm	13.3mm	M10

* For extended-range bushings.

ROUND CLAMPS

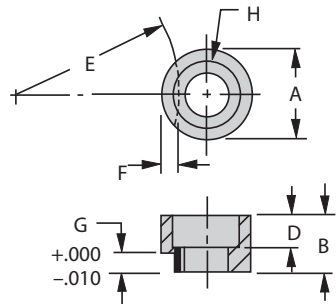

13

Alternative to lock screws when using the "fixed" side of a slip-fixed SF bushing. Round clamps have less clearance under their heads, to clamp bushings tighter (which is why you cannot use them on the bushing's "slip" side). Use them with a Socket-Head Cap Screw.

STANDARD MOUNTING (INCH)

PART NO.	A DIA	B	D	E	F	G	H SOCKET-HEAD CAP SCREW	REPLACES LOCK SCREW
RC-01	5/8	5/16	5/32	17/32	.109	.125	5/16-18	LS-1
RC-02		7/16	7/32	29/32	.125	.188		LS-2
RC-03	3/4	1/2	9/32	1-13/32	.156	.188	3/8-16	LS-3
RC-04*		17/32	1/4	2-1/2		.219		LS-4
RC-05*		9/16				.250		LS-5

STANDARD MOUNTING (METRIC)

PART NO.	A DIA	B	D	E	F	G	H SOCKET-HEAD CAP SCREW	REPLACES LOCK SCREW
RCM-1	13mm	8mm	4mm	9.5mm	2.8mm	3mm	M5	LSM-1
RCM-3	16mm	10mm	5mm	15mm	3.3mm	4mm	M6	LSM-3
RCM-5	20mm	12mm	5mm	30mm	3.8mm	5.5mm	M8	LSM-5
RCM-7	24mm	16mm	7mm	80mm	4.5mm	7mm	M10	LSM-7

* For extended-range bushings.

LOCKSCREWS AND CLAMPS

ROUND END CLAMPS

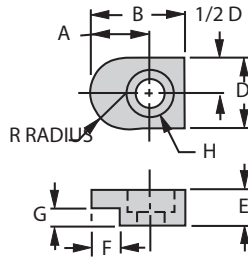

A heavy-duty alternative to lockscrews. Allows locating tapped hole farther away from bushing to avoid interference with a larger liner. Use on either the "slip" or "fixed" side of a slip-fixed renewable bushing. Available in two heights: standard for recessed liner mounting; tall for projected head-liner mounting. Use with a Socket-Head Cap Screw.

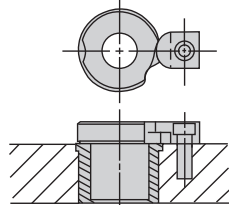

Standard Mounting

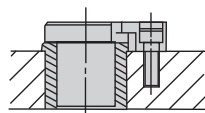

Projected Mounting

STANDARD MOUNTING (INCH)

PART NO.	A	B	D	E	F	G	H SOCKET-HEAD CAP SCREW	R
RK-01	7/16	3/4	5/4	5/16	3/16	1/8	1/4-20	5/16
RK-02	1/2			3/8	1/4	3/16		
RK-03	5/8	1	3/4	3/8	5/16	3/16	5/16-18	3/8
RK-04*	11/16	1-1/8	3/4	7/16	5/16	7/32	3/8-16	3/8
RK-05*				1/2		1/4		

PROJECTED MOUNTING (INCH)

RK-10	7/16	3/4	5/8	3/8	3/16	7/32	1/4-20	5/16
RK-11				1/4				
RK-12	1/2	3/4	5/8	1/2	1/4	5/16	3/8-16	3/8
RK-13				3/8				
RK-14	5/8	1	3/4	1/2	5/16	3/8	3/8-16	3/8

* For extended-range bushings.

FLAT CLAMPS

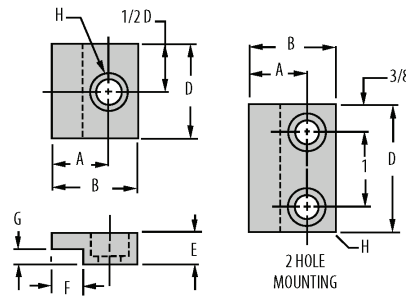
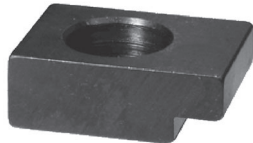

Use to lock FM-type fixed-renewable bushings which have a milled locking flat. Available in two heights: standard for recessed liner mounting; tall for projected head-liner mounting. Use with one or two Socket-Head Cap Screws.

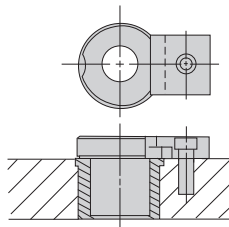

Standard Mounting

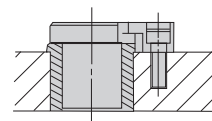

Projected Mounting

STANDARD MOUNTING (INCH)

PART NO.	NO. OF HOLES	A	B	D	E	F	G	H SOCKET-HEAD CAP SCREW
FC-01	1	1/2	7/8	5/8	5/16	3/16	1/8	1/4-20
FC-02		5/8	1	1	3/8	1/4	3/16	5/16-18
FC-03		1-1/8	1	3/8	5/16	3/16	1/8	1/4-20
FC-04*	1	51/64	1-11/64	1-1/4	3/8	27/64	7/32	3/8-16
FC-05*	2			1-3/4				
FC-06*	1			1-1/4	1/2			
FC-07*	2			1-3/4				

PROJECTED MOUNTING (INCH)

FC-10	1	1/2	7/8	5/8	3/8	3/16	7/32	1/4-20
FC-11							1/4	
FC-12	1	5/8	1	1	1/2	1/4	5/16	5/16-18
FC-13							3/8	

* For extended-range bushings.

CHIP-BREAKER BUSHINGS



CH

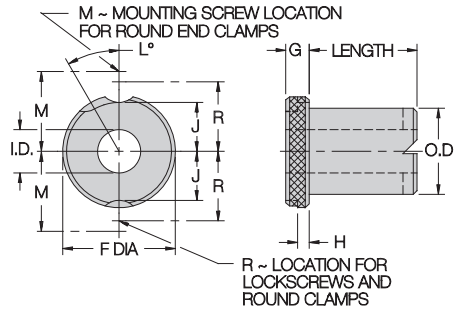

INCH

BODY OD	F	G	H	J	L	M	R	LOCK SCREW
5/16	35/64			11/64	65°	5/8	1/2	
1/2	51/64	1/4	1/8	19/64	65°	3/4	5/8	LS-1
3/4	1-3/64			27/64	50°	7/8	3/4	
1	1-27/64	3/8	3/16	19/32	35°	1-7/64	59/64	LS-2
1-3/8	1-51/64			25/32	30°	1-19/64	1-7/64	
1-3/4	2-19/64	3/8	3/16	1	30°	1-41/64	1-25/64	LS-3
2-1/4	2-51/64			1-1/4	25°	1-57/64	1-41/64	

METRIC

8mm	15mm	6mm	3mm	4.5mm	65°		11.5mm	LSM-1
10mm	18mm			6mm	65°		13mm	LSM-2
12mm	22mm			7.5mm	60°		16mm	LSM-3
15mm	26mm	8mm	4mm	9.5mm	50°		18mm	LSM-4
18mm	30mm			11.5mm	50°		20mm	
22mm	34mm			13mm	35°		23.5mm	LSM-5
26mm	39mm			15.5mm	35°		26mm	LSM-6
30mm	46mm	10mm	5.5mm	19mm	30°		29.5mm	
35mm	52mm			22mm	30°		32.5mm	
42mm	59mm			25.5mm	30°		36mm	
48mm	66mm			28.5mm	30°		41mm	LSM-7
55mm	74mm	12mm	7mm	32.5mm	25°		45mm	LSM-8
62mm	82mm			36.5mm	25°		49mm	

APPLICATIONS:

Similar to an SF renewable bushing, but with specially designed chip-breaking notches on the drill-exit end. Use to break up chips from tough stringy materials, to reduce friction and heat buildup. Reduces bushing wear at the drill-exit end and reduces the chance of tool or workpiece damage. A chip-breaker bushing should extend beyond its liner to allow chips to escape. Chip breakers are also available on other bushing types such as P, H, and DC (directed coolant).

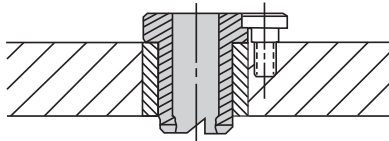

ORDERING EXAMPLES:

- CH-20-16-.1250 Standard inch SF-type bushing with chip breaker, inch ID
 CH-20-16-.1772 Standard inch SF-type bushing with chip breaker, mm ID (.1772 = 4.50mm)

- CH-20-16-.1250 NCB No counterbore on long bushings marked with * (no counterbore is standard on all other bushings)
 CHM-10-20-4.50 Standard metric SF-type bushing with chip breaker
 PCH-20-16-.1250 P bushing with chip breaker
 HCH-20-16-.1250 H bushing with chip breaker
 DCCH-20-16-.1250 Directed coolant bushing with chip breaker

STANDARD ID TOLERANCES:

From #80 to 1/4"	+0.001/+0.0004	From .35 to 3mm	+0.02/+0.008mm
Over 1/4 to 3/4"	+0.001/+0.0005	Over 3 to 6mm	+0.04/+0.012mm
Over 3/4 to 1-1/2"	+0.002/+0.0006	Over 6 to 10mm	+0.05/+0.014mm
Over 1-1/2 to 2-3/4"	+0.003/+0.0007	Over 10 to 18mm	+0.06/+0.017mm
		Over 18 to 30mm	+0.07/+0.020mm
		Over 30 to 50mm	+0.09/+0.025mm

(G6 tolerance)

ID RANGE	OD	LENGTH	ANSI PART NO.	LOCK SCREW
.0625-.0934 1/16-#43 1.60-2.35mm	5/16 .3125-.3123	*3/4	CH-20-12	LS-1
		*1	CH-20-16	RC-01
		*1-3/8	CH-20-22	RK-01
		*1-3/8	CH-20-22	RK-10
.0935-.1935 #42-#10 2.40-4.90mm		*3/4	CH-20-12	LS-1
		*1	CH-20-16	RC-01
		*1-3/8	CH-20-22	RK-01
		*1-3/8	CH-20-22	RK-10
.1405-.3438 #28-11/32 3.60-8.70mm	1/2 .5000-.4998	*3/4	CH-32-12	LS-1
		*1	CH-32-16	RC-01
		*1-3/8	CH-32-22	RK-01
		*1-3/4	CH-32-28	RK-10
.2812-.5625 9/32-9/16 7.20-14.00mm	3/4 .7500-.7498	1	CH-48-16	LS-1
		1-3/8	CH-48-22	RC-01
		1-3/4	CH-48-28	RK-01
		2-1/8	CH-48-34	RK-11
.4688-.7812 15/32-25/32 11.50-19.50mm	1 1.0000-.9998	1	CH-64-16	LS-2
		1-3/8	CH-64-22	RC-02
		1-3/4	CH-64-28	RK-02
		2-1/8	CH-64-34	RK-12
.7188-1.0625 23/32-1-1/16 18.50-27.00mm	1-3/8 1.3750-1.374	1	CH-88-16	LS-2
		1-3/8	CH-88-22	RC-02
		1-3/4	CH-88-28	RK-02
		2-1/8	CH-88-34	RK-12
.9688-1.4062 31/32-1-13/32 25.00-35.00mm	1-3/4 1.7500-1.7497	1-3/8	CH-112-22	LS-3
		1-3/4	CH-112-28	RC-03
		2-1/8	CH-112-34	RK-03
		2-1/2	CH-112-40	RK-13
1.3438-1.8750 1-11/32-1-7/8 35.00-47.00mm	2-1/4 2.2500-2.2496	1-3/8	CH-144-22	LS-3
		1-3/4	CH-144-28	RC-03
		2-1/8	CH-144-34	RK-03
		2-1/2	CH-144-40	RK-13
		3	CH-144-48	

* INFO+: Counterbored, leaving correct drill-bearing length and clearance (see page 537 for bearing length).

CHIP-BREAKER BUSHINGS – METRIC



CHM

ID RANGE (G6)	OD (h5)	LENGTH	ANSI PART NO.	LOCK SCREW
1.00-4.00mm	8mm 8.000-7.994mm	*10mm	CHM-8-10	LSM-1 LSM-2 RCM-1 RCM-2
		*16mm	CHM-8-16	
4.01-6.00mm	10mm 10.000-9.994mm	12mm	CHM-10-12	LSM-3 LSM-4 RCM-3 RCM-4
		20mm	CHM-10-20	
		25mm	CHM-10-25	
6.01-8.00mm	12mm 12.000-11.992mm	12mm	CHM-12-12	LSM-3 LSM-4 RCM-3 RCM-4
		20mm	CHM-12-20	
		25mm	CHM-12-25	
8.01-10.00mm	15mm 15.000-14.992mm	16mm	CHM-15-16	LSM-3 LSM-4 RCM-3 RCM-4
		28mm	CHM-15-28	
		36mm	CHM-15-36	
10.01-12.00mm	18mm 18.000-17.992mm	16mm	CHM-18-16	LSM-3 LSM-4 RCM-3 RCM-4
		28mm	CHM-18-28	
		36mm	CHM-18-36	

ID RANGE (G6)	OD (h5)	LENGTH	ANSI PART NO.	LOCK SCREW
12.01-15.00mm	22mm 22.000-21.991mm	20mm	CHM-22-20	LSM-5 LSM-6 RCM-5 RCM-6
		36mm	CHM-22-36	
		45mm	CHM-22-45	
15.01-18.00mm	26mm 26.000-25.991mm	20mm	CHM-26-20	LSM-5 LSM-6 RCM-5 RCM-6
		36mm	CHM-26-36	
		45mm	CHM-26-45	
18.01-22.00mm	30mm 30.000-29.991mm	25mm	CHM-30-25	LSM-5 LSM-6 RCM-5 RCM-6
		45mm	CHM-30-45	
		56mm	CHM-30-56	
22.01-26.00mm	35mm 35.000-34.989mm	25mm	CHM-35-25	LSM-5 LSM-6 RCM-5 RCM-6
		45mm	CHM-35-45	
		56mm	CHM-35-56	
26.01-30.00mm	42mm 42.000-41.989mm	30mm	CHM-42-30	LSM-5 LSM-6 RCM-5 RCM-6
		56mm	CHM-42-56	
		67mm	CHM-42-67	
30.01-35.00mm	48mm 48.000-47.989mm	30mm	CHM-48-30	LSM-7 LSM-8 RCM-7 RCM-8
		56mm	CHM-48-56	
		67mm	CHM-48-67	
35.01-42.00mm	55mm 55.000-54.987mm	30mm	CHM-55-30	LSM-7 LSM-8 RCM-7 RCM-8
		56mm	CHM-55-56	
		67mm	CHM-55-67	
42.01-48.00mm	62mm 62.000-61.987mm	35mm	CHM-62-35	LSM-7 LSM-8 RCM-7 RCM-8
		67mm	CHM-62-67	
		78mm	CHM-62-78	

* Small metric drill sizes through .80mm are counterbored 1.00mm diameter, with 3mm drill-bearing length.

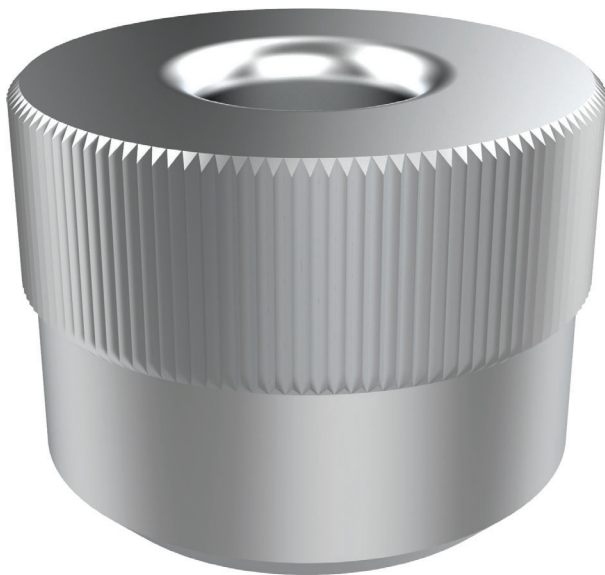

Quick-Ship Bushings

In-Stock and Ready for Same-Day Shipping

CarrLane
MANUFACTURING CO.

DIRECTED-COOLANT BUSHINGS



DC

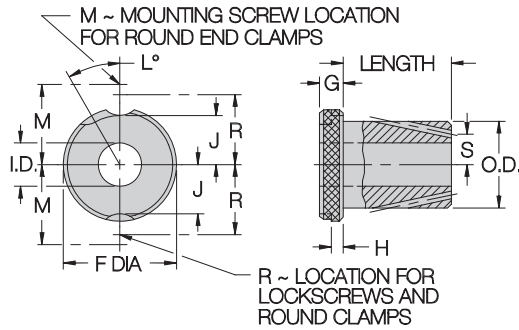

BODY OD	F DIA	G	H	J	L	M	N DIA
5/16	35/64	1/4	1/8	11/64	65°	5/8	5/8
1/2	51/64			19/64	65°	3/4	7/8
3/4	1-3/64			27/64	50°	7/8	1-1/8
1	1-27/64	3/8	3/16	19/32	35°	1-7/64	1-1/2
1-3/8	1-51/64			25/32	30°	1-19/64	1-7/8
1-3/4	2-19/64			1	30°	1-41/64	2-3/8
2-1/4	2-51/64			1-1/4	25°	1-57/64	2-7/8

BODY OD	P	Q	R	S	T DIA	U DIA	V
5/16	3/32	3/16	1/2	5/64	.067	25/64	5/32
1/2	3/32	5/16**	5/8	9/64	.093	19/32**	7/32**
3/4	1/8	5/16	3/4	17/64	.104	55/64	7/32
1	1/8	5/16	59/64	23/64	.125	1-5/32	7/32
1-3/8	3/16	7/16	1-7/64	17/32	.147	1-17/32	9/32
1-3/4	3/16		1-25/64	11/16	.173	1-31/32	
2-1/4	3/16		1-41/64	7/8	.173	2-15/32	

** Q = 3/16, U = 39/64, V = 5/32 on 1/2" long liner bushings.

APPLICATIONS:

Similar to an SF renewable bushing, but with passages to direct coolant to the cutting area. This design is particularly good for washing away chips, especially when ordered as the combination Directed Coolant Chip Breaker (DCCH). DC bushings require special liners, DCL or DCHL, to direct coolant from a drilled manifold passage to the holes in the bushing's OD wall. **INFO+**: Important note: Always order matching liner length.

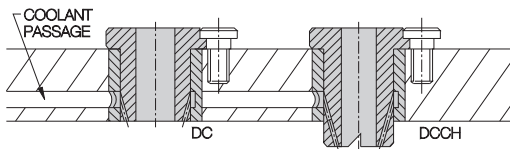

ORDERING EXAMPLES:

DC-20-12-1250	Standard inch directed-coolant bushing, inch ID
DCCH-20-16-1250	Same as above, except with chip breakers (go to next length so that chip breakers extend beyond the liner)
DC-20-12-1772	Standard inch directed-coolant bushing, mm ID (.1772 = 4.50 mm)
DC-20-12-1250 REAMER	Reamer tolerance on ID
DC-20-12-1250 NCB	No counterbore on long bushings marked with * (no counterbore is standard on all other bushings)
DCL-32-12	Liner for renewable bushings above
DCHL-32-12	Head liner for renewable bushings above

STANDARD ID TOLERANCES:

From #80 to 1/4"	+0.001/+0.004	From .35 to 3mm	+0.02/+0.08mm
Over 1/4 to 3/4"	+0.001/+0.005	Over 3 to 6mm	+0.04/+0.12mm
Over 3/4 to 1-1/2"	+0.002/+0.006	Over 6 to 10mm	+0.05/+0.14mm
		Over 10 to 18mm	+0.06/+0.17mm
		Over 18 to 30mm	+0.07/+0.20mm
		Over 30 to 50mm	+0.09/+0.25mm
Over 1-1/2 to 2-3/4"	+0.003/+0.007		

REAMER ID TOLERANCES:

From #60 to 1/4"	+0.005/+0.008	From 1 to 3mm	+0.06/+0.12mm
Over 1/4 to 1"	+0.006/+0.010	Over 3 to 6mm	+0.10/+0.18mm
		Over 6 to 10mm	+0.13/+0.22mm
		Over 10 to 18mm	+0.16/+0.27mm
Over 1 to 1-1/2"	+0.008/+0.012	Over 18 to 30mm	+0.20/+0.33mm

STANDARD LINER ID TOLERANCES:

5/16"	+0.001/+0.004	1-3/8"	+0.006/+0.010
1/2"	+0.002/+0.005	1-3/4"	+0.008/+0.012
3/4"	+0.003/+0.006	2-1/4"	+0.010/+0.015
1"	+0.004/+0.007		

ID RANGE	OD	LENGTH	ANSI PART NO.	LOCK SCREW
.0625-.0934 1/16-#43 1.60-2.35mm	5/16 .3125-.3123	*3/4	DC-20-12	LS-1 RC-01 RK-01
		*1	DC-20-16	RK-11
		*1-3/8	DC-20-22	
.0935-.1935 #42-#10 2.40-4.90mm	1/2 .5000-.4998	*3/4	DC-20-12	LS-1 RC-01 RK-01
		*1	DC-20-16	RK-11
		*1-3/8	DC-20-22	
1405-.3438 #28-11/32 3.60-8.70mm	3/4 .7500-.7498	*3/4	DC-32-12	LS-1 RC-01 RK-01 RK-11
		*1	DC-32-16	
		*1-3/8	DC-32-22	
		*1-3/4	DC-32-28	
		*2-1/8	DC-32-34	
.4688-.7812 15/32-25/32 11.50-19.50mm	1 1.0000-.9998	1	DC-48-16	LS-2 RC-02 RK-02 RK-12
		1-3/8	DC-48-22	
		1-3/4	DC-48-28	
		2-1/8	DC-48-34	
		2-1/2	DC-48-40	
.7188-1.0625 23/32-1-1/16 18.50-27.00mm	1-3/8 1.3750-1.3747	1	DC-88-16	LS-2 RC-02 RK-02 RK-12
		1-3/8	DC-88-22	
		1-3/4	DC-88-28	
		2-1/8	DC-88-34	
		2-1/2	DC-88-40	
.9688-1.4062 31/32-1-13/32 25.00-35.00mm	1-3/4 1.7500-1.7497	1-3/8	DC-112-22	LS-3 RC-03 RK-03 RK-13
		1-3/4	DC-112-28	
		2-1/8	DC-112-34	
		2-1/2	DC-112-40	
1.3438-1.8750 1-11/32-1-7/8 35.00-47.00mm	2-1/4 2.2500-2.2496	3	DC-112-48	LS-3 RC-03 RK-03 RK-13
		1-3/8	DC-144-22	
		1-3/4	DC-144-28	
		2-1/8	DC-144-34	
		2-1/2	DC-144-40	

* **INFO+**: Counterbored, leaving correct drill-bearing length and clearance (see page 537 for bearing length).

DIRECTED-COOLANT BUSHINGS

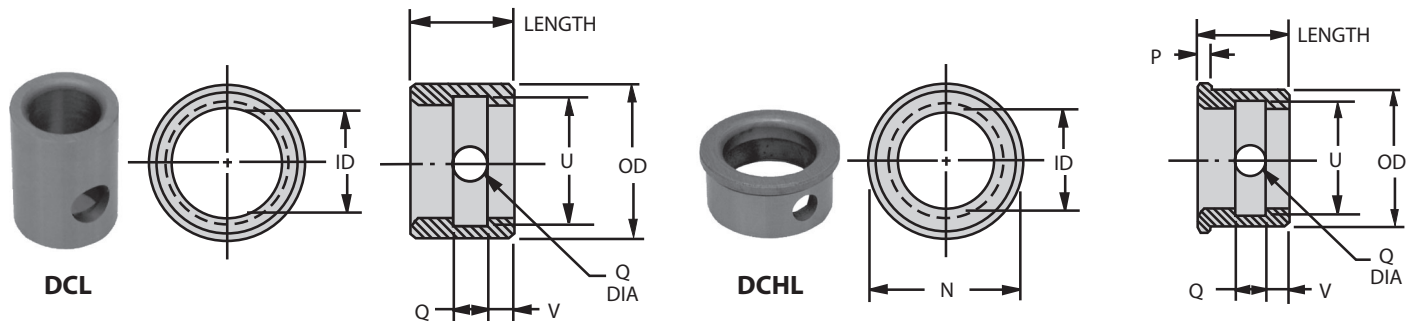

LINERS

ID	OD	LENGTH	PART NO.	MATCHING RENEWABLE BUSHING	
				STANDARD	CHIP BREAKER
5/16	1/2 .5017-.5014 (.520-.515 UNG)	1/2	DCL-32-8	—	DCCH-20-12
		3/4	DCL-32-12	DC-20-12	DCCH-20-16
		1	DCL-32-16	DC-20-16	DCCH-20-22
		1-3/8	DCL-32-22	DC-20-22	—
1/2	3/4 .7518-.7515 (.770-.765 UNG)	1/2	DCL-48-8	—	DCCH-32-12
		3/4	DCL-48-12	DC-32-12	DCCH-32-16
		1	DCL-48-16	DC-32-16	DCCH-32-22
		1-3/8	DCL-48-22	DC-32-22	DCCH-32-28
		1-3/4	DCL-48-28	DC-32-28	DCCH-32-34
		2-1/8	DCL-48-34	DC-32-34	—
3/4	1 1.0018-1.0015 (1.020-1.015 UNG)	3/4	DCL-64-12	—	DCCH-48-16
		1	DCL-64-16	DC-48-16	DCCH-48-22
		1-3/8	DCL-64-22	DC-48-22	DCCH-48-28
		1-3/4	DCL-64-28	DC-48-28	DCCH-48-34
		2-1/8	DCL-64-34	DC-48-34	DCCH-48-40
		2-1/2	DCL-64-40	DC-48-40	—
1	1-3/8 1.3772-1.3768 (1.395-1.390 UNG)	3/4	DCL-88-12	—	DCCH-64-16
		1	DCL-88-16	DC-64-16	DCCH-64-22
		1-3/8	DCL-88-22	DC-64-22	DCCH-64-28
		1-3/4	DCL-88-28	DC-64-28	DCCH-64-34
		2-1/8	DCL-88-34	DC-64-34	DCCH-64-40
		2-1/2	DCL-88-40	DC-64-40	DCCH-64-48
		3	DCL-88-48	DC-64-48	—
1-3/8	1-3/4 1.7523-1.7519 (1.770-1.765 UNG)	3/4	DCL-112-12	—	DCCH-88-16
		1	DCL-112-16	DC-88-16	DCCH-88-22
		1-3/8	DCL-112-22	DC-88-22	DCCH-88-28
		1-3/4	DCL-112-28	DC-88-28	DCCH-88-34
		2-1/8	DCL-112-34	DC-88-34	DCCH-88-40
		2-1/2	DCL-112-40	DC-88-40	DCCH-88-48
		3	DCL-112-48	DC-88-48	—
1-3/4	2-1/4 2.2525-2.2521 (2.270-2.265 UNG)	1	DCL-144-16	—	DCCH-112-22
		1-3/8	DCL-144-22	DC-112-22	DCCH-112-28
		1-3/4	DCL-144-28	DC-112-28	DCCH-112-34
		2-1/8	DCL-144-34	DC-112-34	DCCH-112-40
		2-1/2	DCL-144-40	DC-112-40	DCCH-112-48
		3	DCL-144-48	DC-112-48	—
2-1/4	2-3/4 2.7526-2.7522 (2.770-2.765 UNG)	1	DCL-176-16	—	DCCH-144-22
		1-3/8	DCL-176-22	DC-144-22	DCCH-144-28
		1-3/4	DCL-176-28	DC-144-28	DCCH-144-34
		2-1/8	DCL-176-34	DC-144-34	DCCH-144-40
		2-1/2	DCL-176-40	DC-144-40	DCCH-144-48
		3	DCL-176-48	DC-144-48	—

HEAD LINERS

HEAD LINER PART NO.	MATCHING RENEWABLE BUSHING	
	STANDARD	CHIP BREAKER
DCHL-32-8	—	DCCH-20-12
DCHL-32-12	DC-20-12	DCCH-20-16
DCHL-32-16	DC-20-16	DCCH-20-22
DCHL-32-22	DC-20-22	—
DCHL-48-8	—	DCCH-32-12
DCHL-48-12	DC-32-12	DCCH-32-16
DCHL-48-16	DC-32-16	DCCH-32-22
DCHL-48-22	DC-32-22	DCCH-32-28
DCHL-48-28	DC-32-28	DCCH-32-34
DCHL-48-34	DC-32-34	—
DCHL-64-12	—	DCCH-48-16
DCHL-64-16	DC-48-16	DCCH-48-22
DCHL-64-22	DC-48-22	DCCH-48-28
DCHL-64-28	DC-48-28	DCCH-48-34
DCHL-64-34	DC-48-34	DCCH-48-40
DCHL-64-40	DC-48-40	—
DCHL-88-12	—	DCCH-64-16
DCHL-88-16	DC-64-16	DCCH-64-22
DCHL-88-22	DC-64-22	DCCH-64-28
DCHL-88-28	DC-64-28	DCCH-64-34
DCHL-88-34	DC-64-34	DCCH-64-40
DCHL-88-40	DC-64-40	DCCH-64-48
DCHL-88-48	DC-64-48	—
DCHL-112-12	—	DCCH-88-16
DCHL-112-16	DC-88-16	DCCH-88-22
DCHL-112-22	DC-88-22	DCCH-88-28
DCHL-112-28	DC-88-28	DCCH-88-34
DCHL-112-34	DC-88-34	DCCH-88-40
DCHL-112-40	DC-88-40	DCCH-88-48
DCHL-112-48	DC-88-48	—
DCHL-144-16	—	DCCH-112-22
DCHL-144-22	DC-112-22	DCCH-112-28
DCHL-144-28	DC-112-28	DCCH-112-34
DCHL-144-34	DC-112-34	DCCH-112-40
DCHL-144-40	DC-112-40	DCCH-112-48
DCHL-144-48	DC-112-48	—
DCHL-176-16	—	DCCH-144-22
DCHL-176-22	DC-144-22	DCCH-144-28
DCHL-176-28	DC-144-28	DCCH-144-34
DCHL-176-34	DC-144-34	DCCH-144-40
DCHL-176-40	DC-144-40	DCCH-144-48
DCHL-176-48	DC-144-48	—

OIL-GROOVE BUSHINGS



APPLICATIONS:

Oil grooves are available on most drill-bushing types, including P, H, and SF. Use when you need complete drill lubrication and cooling, such as when drilling hardened steel. Oil grooves are specially designed coolant passageways in the bushing's ID wall. Choose from 25 different groove styles. End wipers are also available, to keep out dirt and chips.

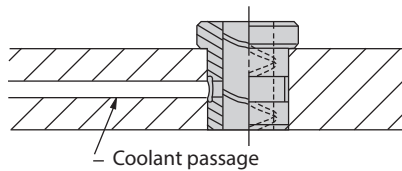

ORDERING EXAMPLES:

P-48-16-.5000-AJ	P bushing with AJ oil groove, inch ID
P-48-16-.4724-AJ	P bushing with AJ oil groove, mm ID (.4724 = 12.00mm)
P-48-16-.5000-AJ-AAA	P bushing with AJ oil groove and AAA wiper
SF-48-16-.5000-AJ	SF bushing with AJ oil groove

THREE GENERAL TYPES:

1. With oil hole. A single radial hole in the bushing wall allows coolant to flow from a manifold passage to the internal oil grooves. Bushing must be installed to line up the radial hole with the manifold passage.

2. With oil hole and external groove. OD groove allows coolant to flow around the bushing, then through the radial hole in the bushing's wall to the internal oil grooves. Allows installing the bushing at any orientation, and mounting bushings in series using a single manifold passage. This type is our most popular.

3. Without oil feed. No external coolant feed through a manifold passage, so all coolant enters through the top. This type is also commonly used as a bearing bushing, packed with oil or grease.

OIL-GROOVE STYLES:

We offer a wide selection of oil-groove styles in each general type. This allows choosing a style to suit various operating conditions, lubrication requirements, and individual preferences.

OPTIONAL WIPERS:

To guard against dirt and chips entering the bushing ID, order oil-groove bushings with a wiper end. Note: do not order an oil-groove style that breaks out at the wiper end (AA, AB, AG, AH, AD, or AE). Order style AAA for headless bushings (install wiper in either direction). Order style ABB or ACC for head-type bushings.

TECHNICAL DATA:

Oil-groove dimensions - 1/16" wide x 1/32" deep
 Oil-hole dimensions - 1/4" diameter
 External-groove dimensions - 5/16" wide x 3/64" deep
 Allowable ID range - 1/2" to 8"
 Allowable length range - 1/2" to 8"
 Oil grooves stop 1/8" short of bushing end.

OPTIONAL WIPERS

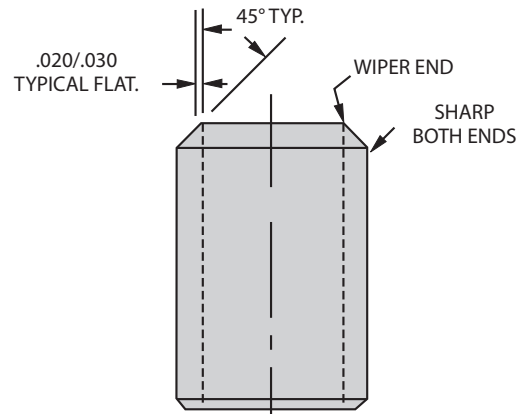

STYLE AAA
HEADLESS BUSHINGS

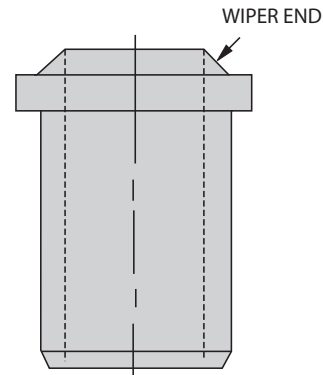

STYLE ABB
HEAD-TYPE BUSHINGS

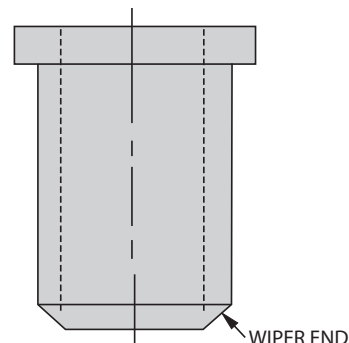

STYLE ACC
HEAD-TYPE BUSHINGS

OIL-GROOVE BUSHINGS

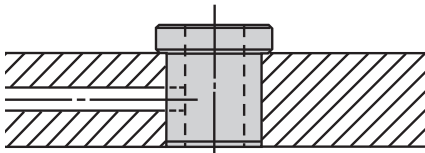



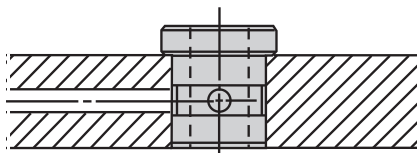

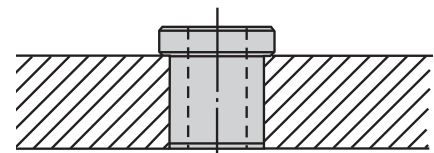

**WITH
OIL HOLE**

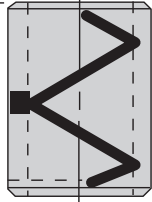
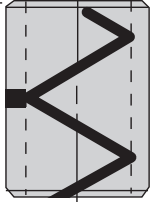
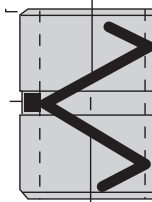
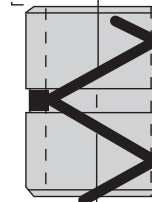
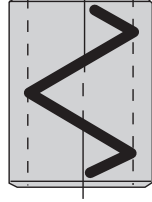
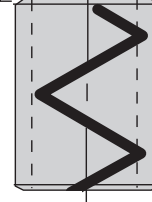
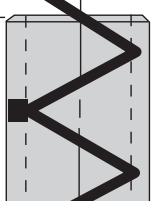
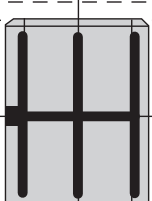
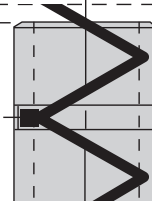
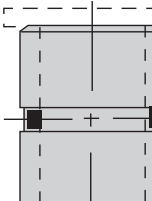
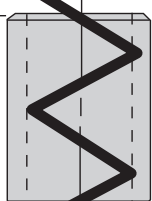
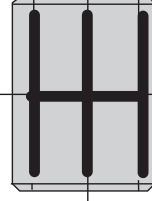

**WITH OIL HOLE &
EXTERNAL GROOVE**

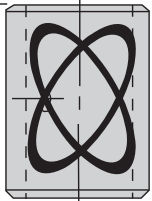

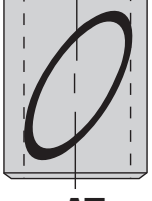
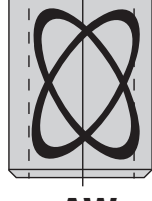
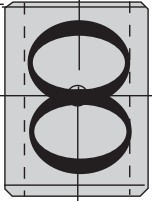
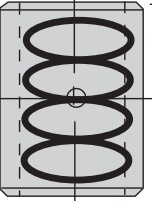
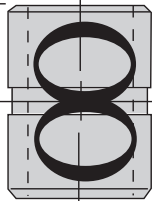
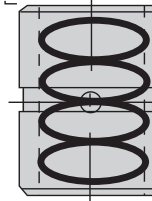
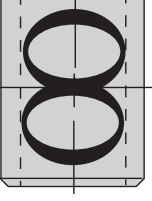
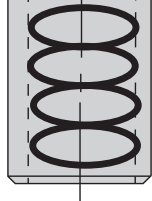
**WITHOUT
OIL FEED**

 AC Helix	 AA Helix Open Bottom	 AJ Helix	 AG Helix Open Bottom	 AF Helix	 AD Helix Open Bottom
 AB Helix Open both ends	 AL Straight	 AH Helix Open both ends	 AO Two Holes	 AE Helix Open both ends	 AK Straight
 AR Loop	 AU Double Loop	 AS Loop	 AV Double Loop	 AT Loop	 AW Double Loop
 AN Figure 8	 AX Double Figure 8	 AP Figure 8	 AY Double Figure 8	 AQ Figure 8	 AZ Double Figure 8
				 AM Helix with ID groove	

OIL-GROOVE BUSHINGS

OIL-GROOVE CONVERSION CHART

Carr Lane Mfg.	Ace	Acme	American	Briney	Economy	United	Universal	Welch
Style AA	Type 1	Style 5	Style 1	Style A	Style A	Style 1A	Style A	Style A
Style AB	Type 2	Style 8	Style 2	Style B	Style B	Style 2A	Style B	Style B
Style AC	Type 3	Style 2	Style 3	Style C	Style C	Style 3A	Style C	Style C
Style AD	Type 4	Style 4	Style 4	Style D	Style D	Style 1	Style D	Style D
Style AE	Type 6	Style 7	Style 5	Style E	Style E	Style 2	Style E	Style E
Style AF	Type 5	Style 1	Style 6	Style F	Style F	Style 3	Style F	Style F
Style AG	Type 7	Style 6	Style 7	Style G	Style G	Style 1B	Style G	Style G
Style AH	Type 8	Style 9	Style 8	Style H	Style H	Style 2B	Style H	Style H
Style AJ	Type 9	Style 3	Style 9	Style J	Style J	Style 3B	Style J	Style J
Style AK	Type 10	Style 10	Style 10	Style K	Style K	Style 4	Style K	Style K
Style AL	Type 11	Style 11	Style 11	Style L	Style L	Style 4A	Style L	Style L
Style AM	Type 12	—	Style 12	Style M	Style M	Style 6	Style M	Style M
Style AN	Type 14	Style 20	Style 13	Style N	Style N	Style 7A	Style N	Style N
Style AO	Type 13	Style 12	Style 14	Style O	Style O	Style 12C	Style O	Style O
Style AP	Type 15	Style 21	Style 15	Style P	Style P	Style 7B	Style P	Style P
Style AQ	Type 16	Style 19	Style 16	Style Q	Style Q	Style 7	Style Q	Style Q
Style AR	Type 17	Style 14	Style 17	Style R	Style R	Style 9A	Style R	Style R
Style AS	Type 18	Style 15	Style 18	Style S	Style S	Style 9B	Style S	Style S
Style AT	Type 19	Style 13	Style 19	Style T	Style T	Style 9	Style T	Style T
Style AU	Type 20	Style 17	Style 20	Style U	Style U	Style 10A	Style U	Style U
Style AV	Type 21	Style 18	Style 21	Style V	Style V	Style 10B	Style V	Style V
Style AW	Type 22	Style 16	Style 22	Style W	Style W	Style 10	Style W	Style W
Style AX	Type 23	Style 23	Style 23	Style X	Style X	Style 8A	Style X	Style X
Style AY	Type 24	Style 24	Style 24	Style Y	Style Y	Style 8B	Style Y	Style Y
Style AZ	Type 25	Style 22	Style 25	Style Z	Style Z	Style 8	Style Z	Style Z

WIPER CONVERSION CHART

Carr Lane Mfg.	Ace	Acme	American	Briney	Economy	United	Universal	Welch
Style AAA	Type WEA	Style WA	Style A	Style AA	Style AA	Style PE	Style AA	Style AA
Style ABB	Type WEB	Style WB	Style B	Style BB	Style BB	Style HW	Style BB	Style BB
Style ACC	Type WEC	Style WC	Style C	Style CC	Style CC	Style HE	Style CC	Style CC

DIAMOND-GROOVE BUSHINGS



DG

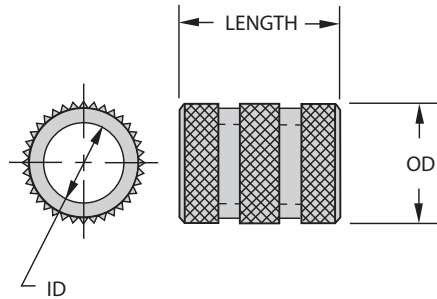

APPLICATIONS:

A bushing for cast-in-place or potted installation. Diamond-knurled OD provides superior holding strength against both rotational and axial forces. Since the bushing's OD is not ground, keep the ID accurately located during casting or potting to ensure accuracy in the finished tool.

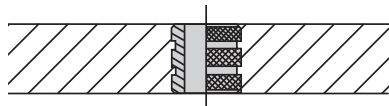

ORDERING EXAMPLES:

DG-26-16-.1875	Standard inch bushing, inch ID
DG-26-16-.1772	Standard inch bushing, mm ID (.1772 = 4.50mm)
DG-26-16-.1875 REAMER	Reamer tolerance on ID
DG-26-16-.1875 NCB	No counterbore on long bushings marked with * (no counterbore is standard on all other bushings)
DGM-8-12-4.50	Standard metric bushing

Standard prices apply only to bushings with a standard-drill-size ID within the stated ID range. See catalog back cover for standard drill sizes and their decimal equivalents. For prices on non-standard ID sizes, including reamer-tolerance and tap-guide bushings, please contact factory.

STANDARD ID TOLERANCES:

From #55 to 1/4"	+ .0001/+ .0004	From 1 to 3mm	+ .002/+ .008mm
		Over 3 to 6mm	+ .004/+ .012mm
Over 1/4 to 3/4"	+ .0001/+ .0005	Over 6 to 10mm	+ .005/+ .014mm
		Over 10 to 18mm	+ .006/+ .017mm
Over 3/4 to 1-1/2"	+ .0002/+ .0006	Over 18 to 19mm	+ .007/+ .020mm
			(G6 tolerance)

REAMER ID TOLERANCES:

From #60 to 1/4"	+ .0005/+ .0008	From 1 to 3mm	+ .006/+ .012mm
		Over 3 to 6mm	+ .010/+ .018mm
Over 1/4 to 1"	+ .0006/+ .0010	Over 6 to 10mm	+ .013/+ .022mm
		Over 10 to 18mm	+ .016/+ .027mm
		Over 18 to 19mm	+ .020/+ .033mm
			(F6 tolerance)

ID RANGE	OD	LENGTH	ANSI PART NO.
.0520-.0995 #55-#39 1.35-2.50mm	13/64 .223-.213	1/4	DG-13-4
		5/16	DG-13-5
		3/8	DG-13-6
		1/2	DG-13-8
.0980-.1406 #40-9/64 2.50-3.50mm	1/4 .275-.260	1/4	DG-16-4
		5/16	DG-16-5
		3/8	DG-16-6
		1/2	DG-16-8
		*3/4	DG-16-12
.1250-.1935 1/8-#10 3.20-4.90mm	5/16 .337-.322	1/4	DG-20-4
		5/16	DG-20-5
		3/8	DG-20-6
		1/2	DG-20-8
		3/4	DG-20-12
.1562-.2570 5/32-F 4.00-6.50mm	13/32 .431-.416	*1	DG-20-16
		1/4	DG-26-4
		5/16	DG-26-5
		3/8	DG-26-6
		1/2	DG-26-8
.1562-.3160 5/32-O 4.00-8.00mm	1/2 .525-.510	3/4	DG-26-12
		*1	DG-26-16
		5/16	DG-32-5
		3/8	DG-32-6
		1/2	DG-32-8
.3125-.4375 5/16-7/16 7.90-11.00mm	5/8 .650-.635	3/4	DG-32-12
		*1	DG-32-16
		3/8	DG-40-6
		1/2	DG-40-8
		3/4	DG-40-12
.3125-.5312 5/16-17/32 8.00-13.00mm	3/4 .775-.760	1	DG-40-16
		1-3/8	DG-40-22
		3/8	DG-48-6
		1/2	DG-48-8
		3/4	DG-48-12
.5000-.6562 1/2-21/32 13.00-16.50mm	7/8 .900-.885	1	DG-48-16
		1-3/8	DG-48-22
		3/8	DG-56-6
		1/2	DG-56-8
		3/4	DG-56-12
.5000-.7656 1/2-49/64 13.00-19.00mm	1 1.035-1.010	1	DG-56-16
		1-3/8	DG-56-22
		1/2	DG-64-8
		3/4	DG-64-12
		1	DG-64-16
		1-3/8	DG-64-22
		1-1/2	DG-64-24

* **INFO+:** Counterbored, leaving correct drill-bearing length and clearance (see page 537 for bearing length).

DIAMOND-GROOVE BUSHINGS – METRIC



DGM

ID RANGE (G6)	OD	LENGTH	ANSI PART NO.
1.00-1.80mm	5mm 5.50-5.25mm	6mm	DGM-5-6
		9mm	DGM-5-9
1.81-2.60mm	5.50-5.25mm	6mm	DGM-5-6
		9mm	DGM-5-9
2.61-3.30mm	6mm 6.65-6.25mm	8mm	DGM-6-8
		12mm	DGM-6-12
		16mm	DGM-6-16
3.31-4.00mm	7mm 7.65-7.25mm	8mm	DGM-7-8
		12mm	DGM-7-12
		16mm	DGM-7-16
4.01-5.00mm	8mm 8.65-8.25mm	8mm	DGM-8-8
		12mm	DGM-8-12
		16mm	DGM-8-16
5.01-6.00mm	10mm 10.65-10.25mm	10mm	DGM-10-10
		16mm	DGM-10-16
		20mm	DGM-10-20

ID RANGE (G6)	OD	LENGTH	ANSI PART NO.
6.01-8.00mm	12mm 12.65-12.25mm	10mm	DGM-12-10
		16mm	DGM-12-16
		20mm	DGM-12-20
8.01-10.00mm	15mm 15.65-15.25mm	12mm	DGM-15-12
		20mm	DGM-15-20
		25mm	DGM-15-25
10.01-12.00mm	18mm 18.65-18.25mm	12mm	DGM-18-12
		20mm	DGM-18-20
		25mm	DGM-18-25
12.01-15.00mm	22mm 22.65-22.25mm	16mm	DGM-22-16
		28mm	DGM-22-28
		36mm	DGM-22-36
15.01-18.00mm	26mm 26.90-26.25mm	16mm	DGM-26-16
		28mm	DGM-26-28
		36mm	DGM-26-36

NOW AVAILABLE IN STAINLESS STEEL!

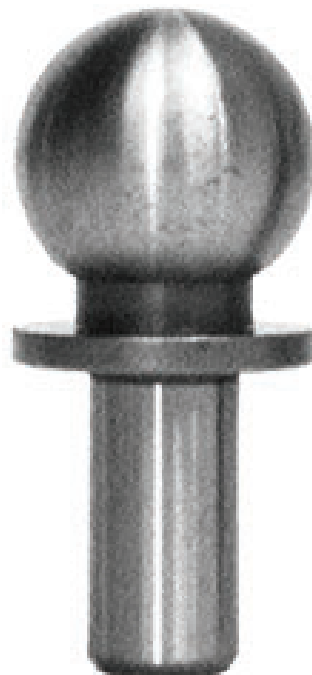

Precision Reference Construction Balls from Carr Lane Mfg.

Ball diameters from 1/4 to 3/4" (6 to 12 mm) various shank diameters and lengths shoulder or adjustable type. See page 248 for more information



SERRATA-GROOVE BUSHINGS



SG

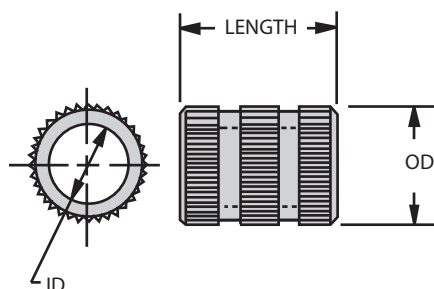

APPLICATIONS:

Can be cast in place or potted, just as a diamond-groove bushing, or can also be pressed into an installation hole. Straight knurl provides less resistance to axial loads than the diamond knurl on a DG bushing. Since the bushing's OD is not ground, keep the ID accurately located during casting or potting to ensure accuracy in the finished tool.

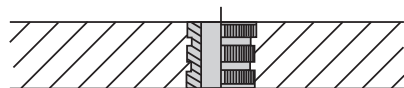

ORDERING EXAMPLES:

SG-26-16-.1875 Standard inch bushing, inch ID
 SG-26-16-.1772 Standard inch bushing, mm ID
 (.1772 = 4.50mm)
 SG-26-16-.1875 REAMER Reamer tolerance on ID
 SG-26-16-.1875 NCB No counterbore on long bushings
 marked with * (no counterbore is
 standard on all other bushings)

Standard prices apply only to bushings with a standard-drill-size ID within the stated ID range. See catalog back cover for standard drill sizes and their decimal equivalents. For prices on non-standard ID sizes, including reamer-tolerance and tap-guide bushings, please contact factory.

STANDARD ID TOLERANCES:

From #55 to 1/4"	+0.001/+0.004	From 1 to 3mm	+0.02/+0.08mm
Over 1/4 to 3/4"	+0.001/+0.005	Over 3 to 6mm	+0.04/+0.12mm
Over 3/4 to 1-1/2"	+0.002/+0.006	Over 6 to 10mm	+0.05/+0.14mm
Over 10 to 18mm	+0.06/+0.17mm	Over 18 to 19mm	+0.07/+0.20mm

(G6 tolerance)

REAMER ID TOLERANCES:

From #60 to 1/4"	+0.005/+0.008	From 1 to 3mm	+0.06/+0.12mm
		Over 3 to 6mm	+0.10/+0.18mm
Over 1/4 to 1"	+0.006/+0.010	Over 6 to 10mm	+0.13/+0.22mm
		Over 10 to 18mm	+0.16/+0.27mm
		Over 18 to 19mm	+0.20/+0.33mm

(F6 tolerance)

ID RANGE	OD	LENGTH	ANSI PART NO.
.0520-.0995 #55-#39 1.35-2.50mm	13/64 .223-.213	1/4	SG-13-4
		5/16	SG-13-5
		3/8	SG-13-6
		1/2	SG-13-8
.0980-.1406 #40-9/64 2.50-3.50mm	1/4 .275-.260	1/4	SG-16-4
		5/16	SG-16-5
		3/8	SG-16-6
		1/2	SG-16-8
		*3/4	SG-16-12
.1250-.1935 1/8-#10 3.20-4.90mm	5/16 .337-.322	1/4	SG-20-4
		5/16	SG-20-5
		3/8	SG-20-6
		1/2	SG-20-8
		3/4	SG-20-12
.1562-.2570 5/32-F 4.00-6.50mm	13/32 .431-.416	*1	SG-20-16
		1/4	SG-26-4
		5/16	SG-26-5
		3/8	SG-26-6
		1/2	SG-26-8
.1562-.3160 5/32-O 4.00-8.00mm	1/2 .525-.510	3/4	SG-26-12
		*1	SG-26-16
		5/16	SG-32-5
		3/8	SG-32-6
		1/2	SG-32-8
.3125-.4375 5/16-7/16 7.90-11.00mm	5/8 .650-.635	3/4	SG-32-12
		*1	SG-32-16
		3/8	SG-40-6
		1/2	SG-40-8
		3/4	SG-40-12
.3125-.5312 5/16-17/32 8.00-13.00mm	3/4 .775-.760	1	SG-40-16
		1-3/8	SG-40-22
		3/8	SG-48-6
		1/2	SG-48-8
		3/4	SG-48-12
.5000-.6562 1/2-21/32 13.00-16.50mm	7/8 .900-.885	1	SG-48-16
		1-3/8	SG-48-22
		3/8	SG-56-6
		1/2	SG-56-8
		3/4	SG-56-12
.5000-.7656 1/2-49/64 13.00-19.00mm	1 1.035-1.010	1	SG-56-16
		1-3/8	SG-56-22
		1/2	SG-64-8
		3/4	SG-64-12
		1	SG-64-16
		1-3/8	SG-64-22
		1-1/2	SG-64-24

* **INFO+**: Counterbored, leaving correct drill-bearing length and clearance (see page 537 for bearing length).

DIAMOND-KNURL UN-A-LOK™ LINER BUSHINGS

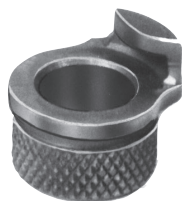

ULD
ULDM

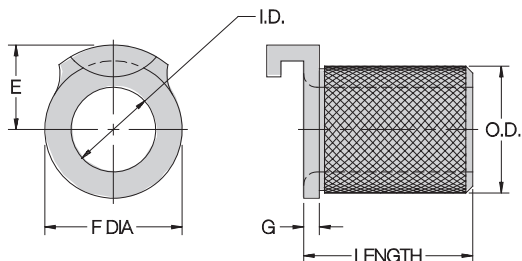

INCH

BODY OD	E	F DIA	G
5/16	1/4	.365	3/32
1/2	3/8	9/16	3/32
3/4	1/2	13/16	3/32
1	21/32	1-1/16	1/8
1-3/8	7/8	1-7/16	1/8

METRIC

BODY OD	E	F DIA	G
12mm	9.5mm	15mm	3mm
15mm	11mm	18mm	3mm
18mm	13mm	22mm	4mm
22mm	15.5mm	26mm	4mm
26mm	17.5mm	30mm	4mm

APPLICATIONS:

A liner for cast-in-place or potted installation, used to hold SF renewable drill bushings. Un-A-Lok™ liners incorporate a special locking tab that eliminates the need for a lockscrew. Holds only the “slip” side of an SF bushing, not the “fixed” side. Diamond-knurled OD provides superior holding strength against both rotational and axial forces. Since the bushing’s OD is not ground, keep the ID accurately located during casting or potting to ensure accuracy in the finished tool.

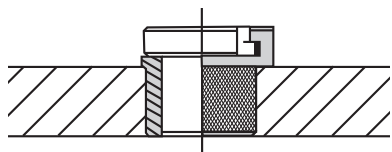

ORDERING EXAMPLES:

ULD-20-5 Standard inch liner bushing
 ULDM-12-10 Standard metric liner bushing

STANDARD LINER ID TOLERANCES:

3/16 to 5/16"	+0.001/+0.004	8 to 10mm	+0.005/+0.014mm
1/2"	+0.002/+0.005	12 to 18mm	+0.006/+0.017mm
3/4"	+0.003/+0.006		(G6 tolerance)
1"	+0.004/+0.007		

INCH

ID	OD	LENGTH	PART NO.
3/16	5/16 .342-.332	5/16	ULD-20-5
		3/8	ULD-20-6
		1/2	ULD-20-8
		3/4	ULD-20-12
5/16	1/2 .533-.523	3/8	ULD-32-6
		1/2	ULD-32-8
		3/4	ULD-32-12
1/2	3/4 .785-.775	1/2	ULD-48-8
		3/4	ULD-48-12
		1	ULD-48-16
3/4	1 1.035-1.025	1/2	ULD-64-8
		3/4	ULD-64-12
		1	ULD-64-16
1	1-3/8 1.415-1.405	1/2	ULD-88-8
		3/4	ULD-88-12
		1	ULD-88-16
		1-3/8	ULD-88-22

METRIC

ID (G6)	OD	LENGTH	PART NO.
8mm	12mm 12.65-12.25mm	10mm	ULDM-12-10
		16mm	ULDM-12-16
10mm	15mm 15.65-15.25mm	12mm	ULDM-15-12
		20mm	ULDM-15-20
		25mm	ULDM-15-25
12mm	18mm 18.65-18.25mm	12mm	ULDM-18-12
		20mm	ULDM-18-20
		25mm	ULDM-18-25
15mm	22mm 22.65-22.25mm	16mm	ULDM-22-16
		28mm	ULDM-22-28
		36mm	ULDM-22-36
18mm	26mm 26.90-26.25mm	16mm	ULDM-26-16
		28mm	ULDM-26-28
		36mm	ULDM-26-36

EZ-CAST LINER BUSHINGS



EZ

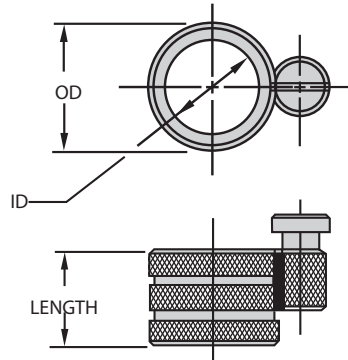

APPLICATIONS:

Another liner for cast-in-place or potted installation, used to hold SF renewable drill bushings. Unlike diamond-knurl unlock liners, EZ-cast liners hold either the “slip” or “fixed” side of an SF bushing, since they include an integral lockscrew holder. Diamond-knurled OD provides superior holding strength against both rotational and axial forces. Since the bushing’s OD is not ground, keep the ID accurately located during casting or potting to ensure accuracy in the finished tool.

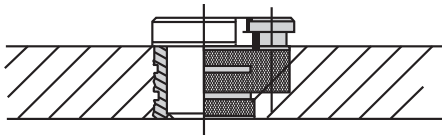

ID RANGE	OD	LENGTH	PART NO.
5/16 .3126-.3129	1/2 .525-.510	1/2	EZ-32-8
		3/4	EZ-32-12
		1	EZ-32-16
1/2 .5002-.5005	3/4 .775-.760	1/2	EZ-48-8
		3/4	EZ-48-12
		1	EZ-48-16
		1-3/8	EZ-48-22
3/4 .7503-.7506	1 1.035-1.010	1/2	EZ-64-8
		3/4	EZ-64-12
		1	EZ-64-16
		1-3/8	EZ-64-22
1 1.0004-1.0007	1-3/8 1.410-1.385	3/4	EZ-88-12
		1	EZ-88-16
		1-3/8	EZ-88-22

ORDERING EXAMPLE:

EZ-32-8 Standard inch liner bushing

STANDARD LINER ID TOLERANCES:

5/16"	+0.0001/+0.0004
1/2"	+0.0002/+0.0005
3/4"	+0.0003/+0.0006
1"	+0.0004/+0.0007

TEMPLATE BUSHINGS



TB

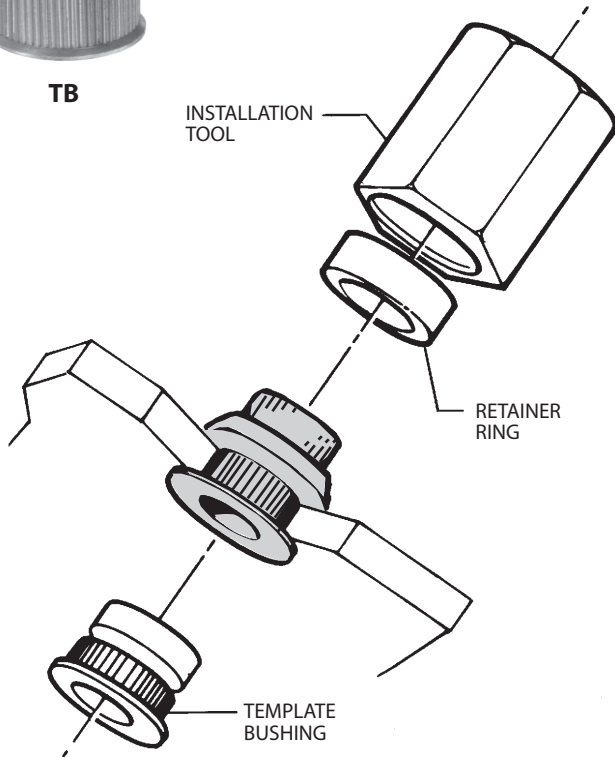

APPLICATIONS:

An economical bushing designed for thin template jig plates from 1/16 to 3/8" thick. Bushings are held in place by a Retainer Ring (order Retainer Ring and Installation Tool separately). The OD serrations prevent the bushing from spinning. Bushings can be removed and reused by breaking the aluminum Retainer Ring (extra rings available separately).

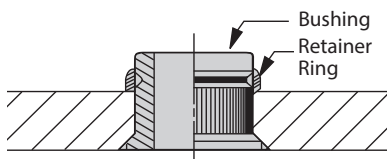

ORDERING EXAMPLES:

TB-24-6-4-.1250 Bushing with 1/8" ID
 TR-10 Matching Retainer Ring for 1/16" thick template
 TR-30 Matching Retainer Ring for 1/8" thick template

Standard prices apply only to bushings with a standard-drill-size ID within the stated ID range. See catalog back cover for standard drill sizes and their decimal equivalents. For prices on non-standard ID sizes, including reamer-tolerance and tap-guide bushings, please contact factory.

STANDARD ID TOLERANCES:

#55 to 1/2" +.0001/+0.011 | 1.30 to 12mm +.002/+0.030mm

CONCENTRICITY:

ID concentric with OD to within .002 TIR

INSTALLATION STEPS

1. LAY OUT HOLES

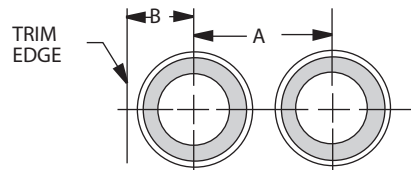

When laying out holes, observe the minimum hole spacing and edge distance listed below:

BUSHING OD	A MINIMUM	B MINIMUM
3/8	.60	.250
1/2	.73	.312
3/4	.98	.438

2. REAM AND COUNTERSINK

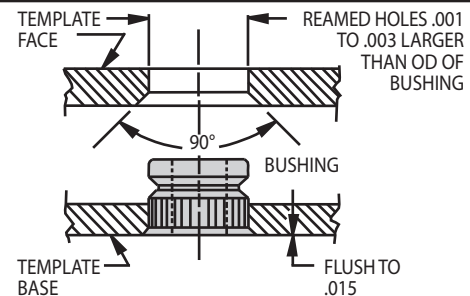

Ream hole .001 to .003 larger than bushing OD. Countersink reamed hole to allow the bushing to seat .015 below flush with surface. For best results, use a piloted countersink tool so that the countersink is concentric and free of chatter marks.

3. INSTALL

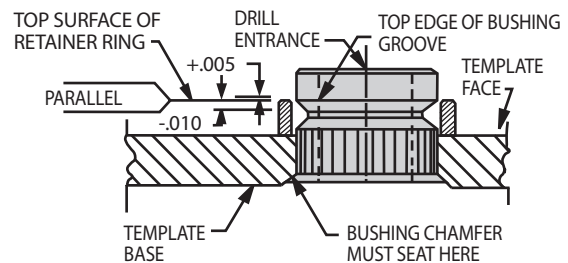

Install Retainer Ring with an arbor press whenever possible. The Installation Tool is also tapped for mounting on a rivet gun or other impact tool. Check that Retainer Ring top surface is within +.005 / -.010 of the bushing groove's top edge before installing.

TEMPLATE BUSHINGS

TEMPLATE BUSHINGS AND RETAINER RINGS

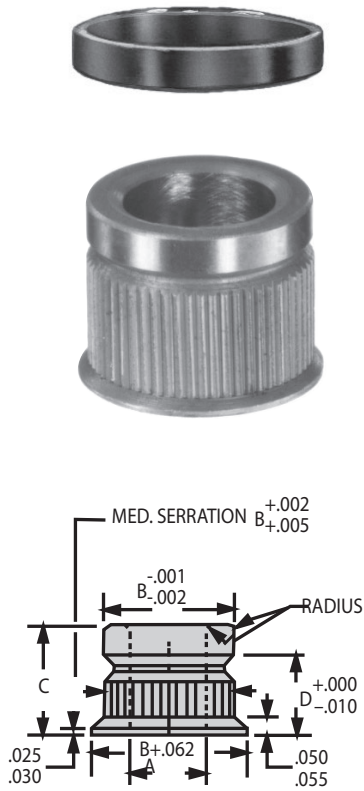

ID RANGE A	OD B	LENGTH C	GRIP D	BUSHING PART NO.	RETAINER RING PART NO.	TEMPLATE THICKNESS
.0520-.1960 #55-#9 1.30-5.00mm	3/8	3/8	1/4	TB-24-6-4	TR-10	1/16
					TR-20	3/32
				TR-30	1/8	
		5/16	TB-24-6-5	TR-10	1/8	
				TR-30	3/16	
				TR-40	1/16	
	1/2	5/16	5/16	TB-24-8-5	TR-10	1/8
					TR-30	3/16
		3/8	5/16	TB-24-8-6	TR-10	3/16
					TR-30	1/4
		7/16	5/16	TB-24-8-7	TR-10	1/4
					TR-30	5/16
.1960-.3160 #9-O 5.00-8.00mm	1/2	3/8	1/4	TB-32-6-4	TR-40	1/16
					TR-50	3/32
				TR-60	1/8	
		5/16	TB-32-6-5	TR-40	1/8	
				TR-60	3/16	
				TR-70	1/8	
	1/2	5/16	5/16	TB-32-8-5	TR-40	1/8
					TR-60	3/16
		3/8	5/16	TB-32-8-6	TR-40	3/16
					TR-60	1/4
		7/16	5/16	TB-32-8-7	TR-40	1/4
					TR-60	5/16
.3125-.5000 5/16-1/2 8.00-12.00mm	3/4	3/8	1/4	TB-48-6-4	TR-40	5/16
					TR-60	3/8
				TR-70	1/16	
		5/16	TB-48-6-5	TR-80	3/32	
				TR-90	1/8	
				TR-70	1/8	
	1/2	5/16	5/16	TB-48-8-5	TR-70	1/8
					TR-90	3/16
		3/8	5/16	TB-48-8-6	TR-70	3/16
					TR-90	1/4
		7/16	5/16	TB-48-8-7	TR-70	1/4
					TR-90	5/16
5/8	1/2	5/8	TB-48-10-8	TR-70	5/16	
				TR-90	3/8	
			TR-70	1/16		
			TR-80	3/32		
			TR-90	1/8		
			TR-70	1/8		

RETAINER RINGS

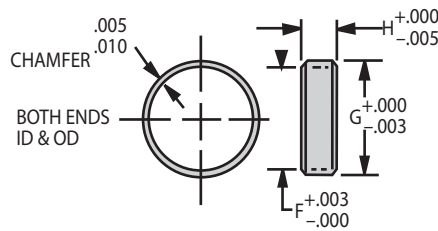

PART NO.	OD B	G OD	H
TR-10	.375	.468	.205
TR-20			.173
TR-30			.142
TR-40	.500	.593	.205
TR-50			.173
TR-60			.142
TR-70	.750	.843	.205
TR-80			.173
TR-90			.142

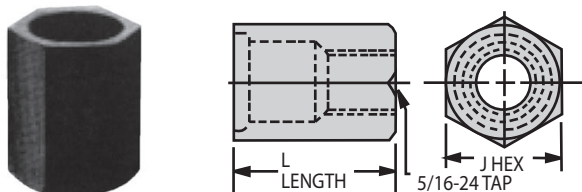

INSTALLATION TOOLS

PART NO.	FOR BUSHING SERIES	FOR RING SERIES	J	L	COMPLETE SET
					PART NO.
TBT-100	TB-24	TR-10,TR-20,TR-30	5/8	1	TBT-400
TBT-200	TB-32	TR-40,TR-50,TR-60	3/4	1	
TBT-300	TB-48	TR-70,TR-80,TR-90	1	1	

THREADED TEMPLATE BUSHINGS



Retainer Ring (TTR)



Threaded Template Bushing (TTB)

STANDARD ID TOLERANCE:

From #55 to 1/2" +.0001/+0.0015
(ID concentric with OD to within .002" TIR)

INSTALLATION:

Drill hole in jig plate to nominal bushing OD (B diameter). Countersink 90° to allow bushing to seat flush to .015" below surface of plate (standard version only, not flanged version). Install and tighten Retainer Ring to secure. To make Retainer Ring installation easier, we offer a handy Socket-Type Installation Tool that fits 1/4" square drives.

APPLICATIONS:

This economical bushing is designed for thin template jig plates from 3/64 to 3/8" thick. Bushings are held in place by a threaded Retainer Ring (order separately). Left-hand thread is self tightening during drilling to prevent the Retainer Ring from loosening. Flush contact of the Retainer Ring against the jig plate ensures perpendicular drill alignment. OD serrations prevent the bushing from rotating during drilling. Choose standard countersunk type for flush mounting, or flanged type for installation without countersinking the jig plate. Threaded Template Bushings can be easily removed to replace or reuse.

ORDERING EXAMPLES:

Available in 3/8", 1/2", 5/8", 3/4", and 1" OD sizes. Standard prices apply to standard bushings only, with any standard inch or metric ID size within the stated range.

- TTB-24-1250 Bushing with 1/8" ID
- TTR-24-3 Matching Retainer Ring for 1/4" thick template

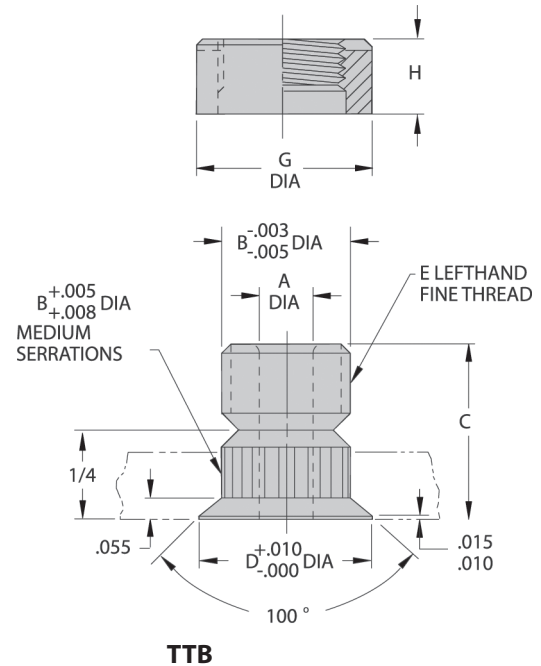

THREADED TEMPLATE BUSHINGS — STANDARD (ORDER BUSHING AND RETAINER RING SEPARATELY)

A ID RANGE	B OD	C LENGTH	D DIA	E	G DIA	H	BUSHING PART NO.	RETAINER RING PART NO.	TEMPLATE THICKNESS
.0520-.1960 #55-#9 1.30-5.00mm	3/8	1/2	.475	3/8-24 LH	1/2	3/8	TTB-24	TTR-24-6	3/64-1/8
						5/16		TTR-24-5	9/64-3/16
						3/16		TTR-24-3	13/64-3/8
.1960-.3160 #9-0 5.00-8.00mm	1/2	1/2	.600	1/2-20 LH	5/8	3/8	TTB-32	TTR-32-6	3/64-1/8
						5/16		TTR-32-5	9/64-3/16
						3/16		TTR-32-3	13/64-3/8
.3125-.4375 5/16-7/16 7.90-11.00mm	5/8	1/2	.725	5/8-18 LH	3/4	3/8	TTB-40	TTR-40-6	3/64-1/8
						5/16		TTR-40-5	9/64-3/16
						3/16		TTR-40-3	13/64-3/8
.3125-.5312 5/16-17/32 8.00-13.00mm	3/4	1/2	.850	3/4-16 LH	1	3/8	TTB-48	TTR-48-6	3/64-1/8
						5/16		TTR-48-5	9/64-3/16
						3/16		TTR-48-3	13/64-3/8
.5000-.7656 1/2-49/64 13.00-19.00mm	1	1/2	1.100	1"-14 LH	1-1/4	3/8	TTB-64	TTR-64-6	3/64-1/8
						5/16		TTR-64-5	9/64-3/16
						3/16		TTR-64-3	13/64-3/8

THREADED TEMPLATE BUSHINGS

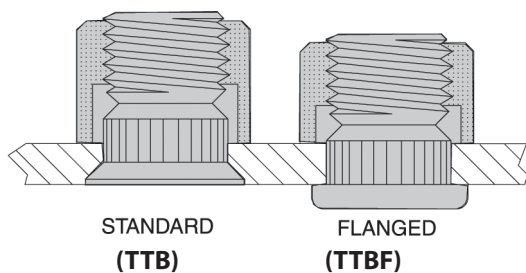

Choose standard countersunk type for flush mounting, or flanged type for installation without countersinking the jig plate.

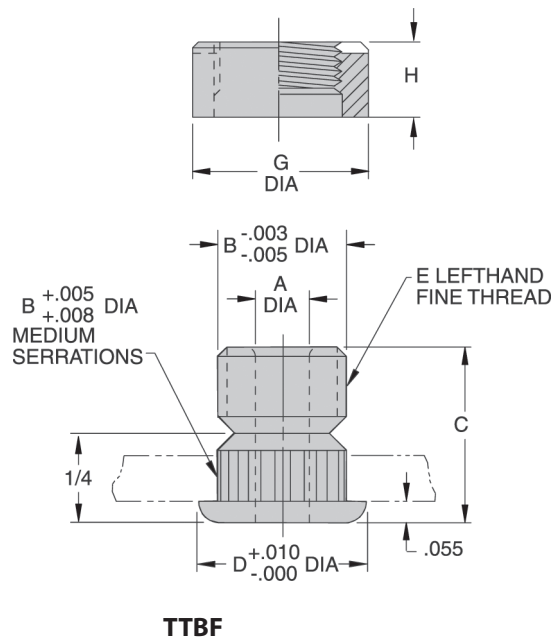

THREADED TEMPLATE BUSHINGS — FLANGED (ORDER BUSHING AND RETAINER RING SEPARATELY)

A ID RANGE	B OD	C LENGTH	D DIA	E	G DIA	H	BUSHING PART NO.	RETAINER RING PART NO.	TEMPLATE THICKNESS
.0520-.1960 #55-#9 1.30-5.00mm	3/8	1/2	.475	3/8-24 LH	1/2	3/8	TTBF-24	TTR-24-6	3/64-1/8
						5/16		TTR-24-5	9/64-3/16
						3/16		TTR-24-3	13/64-3/8
.1960-.3160 #9-0 5.00-8.00mm	1/2	1/2	.600	1/2-20 LH	5/8	3/8	TTBF-32	TTR-32-6	3/64-1/8
						5/16		TTR-32-5	9/64-3/16
						3/16		TTR-32-3	13/64-3/8
.3125-.4375 5/16-7/16 7.90-11.00mm	5/8	1/2	.725	5/8-18 LH	3/4	3/8	TTBF-40	TTR-40-6	3/64-1/8
						5/16		TTR-40-5	9/64-3/16
						3/16		TTR-40-3	13/64-3/8
.3125-.5312 5/16-17/32 8.00-13.00mm	3/4	1/2	.850	3/4-16 LH	1	3/8	TTBF-48	TTR-48-6	3/64-1/8
						5/16		TTR-48-5	9/64-3/16
						3/16		TTR-48-3	13/64-3/8
.5000-.7656 1/2-49/64 13.00-19.00mm	1	5/8	1.100	1"-14 LH	1-1/4	3/8	TTBF-64	TTR-64-6	3/64-1/8
						5/16		TTR-64-5	9/64-3/16
						3/16		TTR-64-3	13/64-3/8

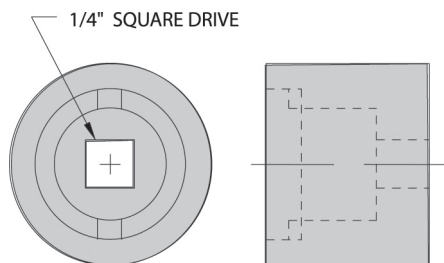

SOCKET-TYPE INSTALLATION TOOLS

PART NO.	FOR INSTALLING RETAINER RINGS		
TTBT-24	TTR-24-3	TTR-24-5	TTR-24-6
TTBT-32	TTR-32-3	TTR-32-5	TTR-32-6
TTBT-40	TTR-40-3	TTR-40-5	TTR-40-6
TTBT-48	TTR-48-3	TTR-48-5	TTR-48-6
TTBT-64	TTR-64-3	TTR-64-5	TTR-64-6

GUN DRILL BUSHINGS



GDL

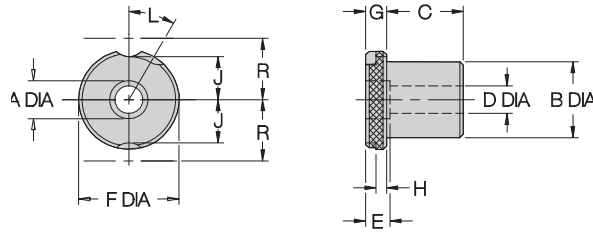

TYPE GDL GUN-DRILL LINER

BODY OD	E	F DIA	G	H	J	L	R	LOCK SCREW
1	7/16	1-27/64	3/8	3/16	19/32	35°	59/64	LS-2
1-3/8	7/16	1-51/64	3/8	3/16	25/32	30°	1-7/64	LS-2
1-3/4	3/4	2-19/64	3/8	3/16	1	30°	1-25/64	LS-2

A ID	B OD	C LENGTH	D	PART NO.	LOCK SCREW
13/64	1 1.0000-9998	1	1/8	GDL-64-16-13	LS-2
1/4			5/32	GDL-64-16-16	
5/16			7/32	GDL-64-16-20	
1/2			11/32	GDL-64-16-32	
3/4			9/16	GDL-64-16-48	
13/64	1-3/8 1.3750-1.3747	1-3/8	1/8	GDL-88-22-13	LS-2
1/4			5/32	GDL-88-22-16	
5/16			7/32	GDL-88-22-20	
1/2			11/32	GDL-88-22-32	
3/4			9/16	GDL-88-22-48	
1			51/64	GDL-88-22-64	
13/64	1-3/4 1.7500-1.7497	1-3/4	1/8	GDL-112-28-13	LS-2
1/4			5/32	GDL-112-28-16	
5/16			7/32	GDL-112-28-20	
1/2			11/32	GDL-112-28-32	
3/4			9/16	GDL-112-28-48	
1			51/64	GDL-112-28-64	
1-3/8			1-3/64	GDL-112-28-88	

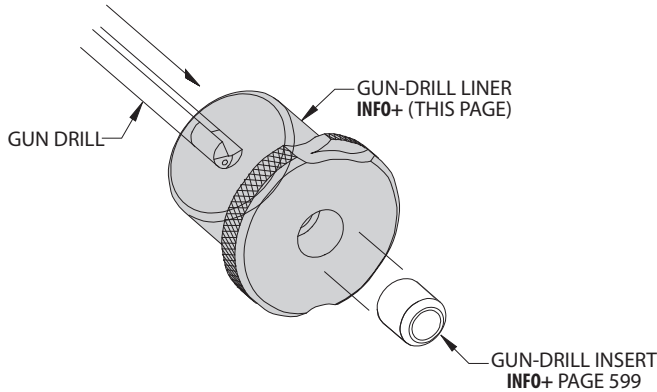

APPLICATIONS:

These bushings are for gun-drilling machines, such as Eldorado, Drillmation, deHoff, and Lahr. Gun-drill bushings are similar to SF renewable bushings, but with the drill bearing at the bushing's head end. Depending on the gun-drilling machine, bushings are either one-piece or two-piece (a liner and an insert).

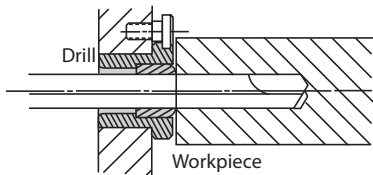

ORDERING EXAMPLE:

GDL-112-28-20 Liner for any insert with a 5/16 OD

Standard prices apply only to bushings with a standard-drill-size ID within the stated ID range. See catalog back cover for standard drill sizes and their decimal equivalents. For prices on non-standard ID sizes, including reamer-tolerance and tap-guide bushings, please contact factory.

STANDARD LINER ID TOLERANCES:

13/64"	+0.0014/+0.0016
1/4 to 5/16"	+0.0015/+0.0017
1/2"	+0.0016/+0.0018
3/4 to 1"	+0.0017/+0.0019
1-3/8"	+0.0021/+0.0023

GUN DRILL BUSHINGS



GDI

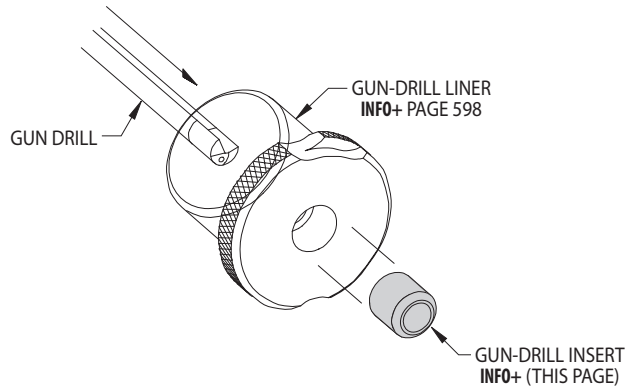
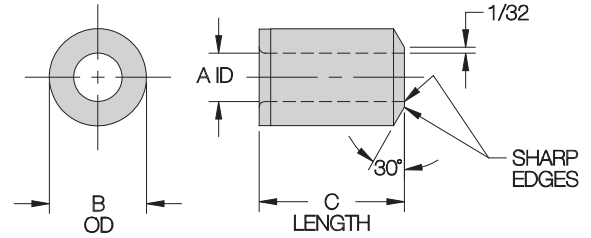

TYPE GDI GUN-DRILL INSERTS

A ID	B OD	C LENGTH	PART NO.	MATCHING LINER
.0635-.0995 #52-#39 1.65-2.50mm	13/64 .2046-.2043	1/2	GDI-13-8	GDL-64-16-13
		3/4	GDI-13-12	GDL-88-22-13
		1	GDI-13-16	GDL-112-28-13
.0980-.1406 #40-9/64 2.50-3.50mm	1/4 .2516-.2513	1/2	GDI-16-8	GDL-64-16-16
		3/4	GDI-16-12	GDL-88-22-16
		1	GDI-16-16	GDL-112-28-16
.1250-.1935 1/8-#10 3.20-4.90mm	5/16 .3141-.3138	1/2	GDI-20-8	GDL-64-16-20
		3/4	GDI-20-12	GDL-88-22-20
		1	GDI-20-16	GDL-112-28-20
.1875-.3160 3/16-0 4.80-8.00mm	1/2 .5017-.5014	1/2	GDI-32-8	GDL-64-16-32
		3/4	GDI-32-12	GDL-88-22-32
		1	GDI-32-16	GDL-112-28-32
.3125-.5312 5/16-17/32 8.00-13.50mm	3/4 .7518-.7515	1/2	GDI-48-8	GDL-64-16-48
		3/4	GDI-48-12	GDL-88-22-48
		1	GDI-48-16	GDL-112-28-48
.5000-.7656 1/2-49/64 13.00-19.00mm	1 1.0018-1.0015	3/4	GDI-64-12	GDL-88-22-64
		1	GDI-64-16	GDL-112-28-64
.6250-1.0312 5/8-1-1/32 16.00-26.00mm	1-3/8 1.3772-1.3768	1	GDI-88-16	GDL-112-28-88

ORDERING EXAMPLES:

- GDI-20-16-.1250 Gun-drill insert for 1-3/4" OD liner
GDL-112-28-20, inch ID
- GDI-20-16-.1772 Gun-drill insert for 1-3/4" OD liner
GDL-112-28-20, mm ID
(.1772 = 4.50mm)

Standard prices apply only to bushings with a standard-drill-size ID within the stated ID range. See catalog back cover for standard drill sizes and their decimal equivalents. For prices on non-standard ID sizes, including reamer-tolerance and tap-guide bushings, please contact factory.

STANDARD ID TOLERANCES:

#52 to 1-1/32" -.0000/+0.0002 | 1.65 to 26mm -.000/+0.005mm

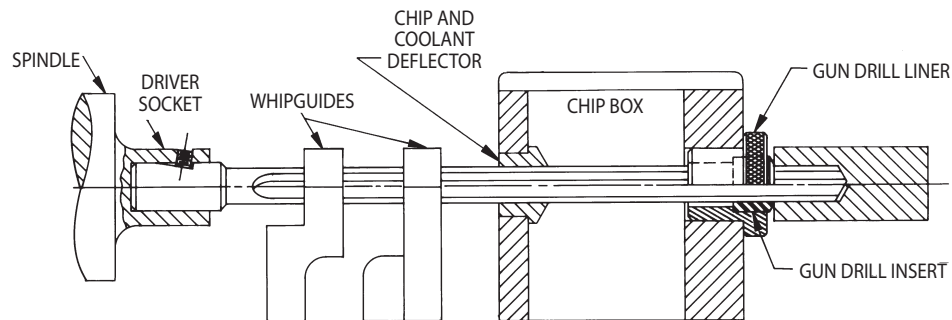

GUN DRILL BUSHINGS



GDE

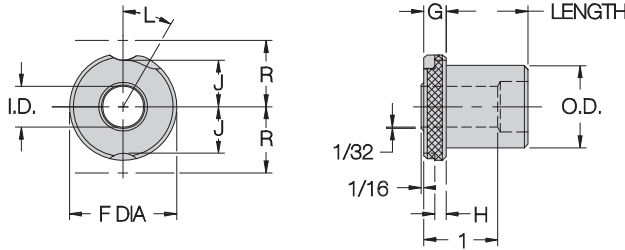

BODY OD	F DIA	G	H	J	L	R
1	1-27/64	3/8	3/16	19/32	35°	59/64
1-3/8	1-51/64	3/8	3/16	25/32	30°	1-7/64

ORDERING EXAMPLES:

GDE-64-12-.1250 Standard gun-drill bushing, inch ID
 GDE-64-12-.1772 Standard gun-drill bushing, mm ID (.1772 = 4.50mm)

STANDARD ID TOLERANCES:

1/8 to 1-1/16" -0.000/+0.002 | 3 to 27mm -0.00/+0.005mm

TYPE GDE — ONE-PIECE ELDORADO TYPE

ID RANGE	OD	LENGTH	PART NO.	LOCK SCREW
.1250-.7812	1 1.0000-.9998	3/4	GDE-64-12	LS-2
1/8-25/32		1	GDE-64-16	
3.20-19.50mm		1-3/8	GDE-64-22	
.1250-1.0625	1-3/8 1.3750-1.3747	1	GDE-88-16	LS-2
1/8-1-1/16		1-3/8	GDE-88-22	
3.20-27.00mm				



GDD

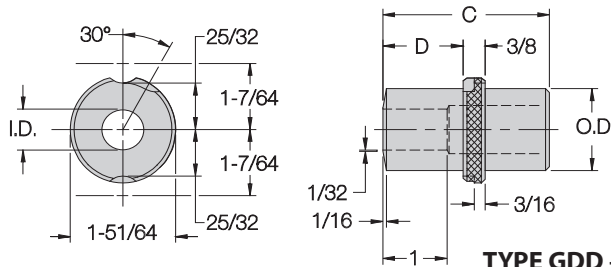

ORDERING EXAMPLES:

GDD-88-30-.1250 Standard gun-drill bushing, inch ID
 GDD-88-30-.1772 Standard gun-drill bushing, mm ID (.1772 = 4.50mm)

STANDARD ID TOLERANCES:

1/8 to 1-1/16" -0.000/+0.002 | 3 to 27mm -0.00/+0.005mm

TYPE GDD — ONE-PIECE ELDORADO DEEP TYPE

ID RANGE	OD	C LENGTH	D EXT.	PART NO.	LOCK SCREW
.1250-1.0625	1-3/8 1.3750-1.3747	1-7/8	1/2	GDD-88-30	LS-2
1/8-1-1/16		2-3/8	1	GDD-88-38	
3.20-27.00mm		2-7/8	1-1/2	GDD-88-46	
		3-3/8	2	GDD-88-54	

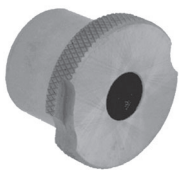

GDH

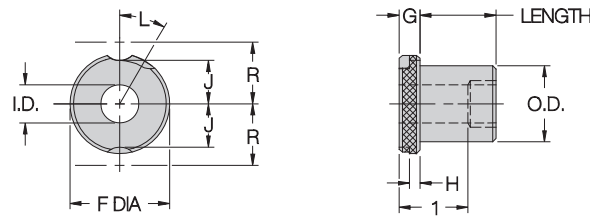

BODY OD	F DIA	G	H	J	L	R
1	1-27/64	3/8	3/16	19/32	35°	59/64
1-3/8	1-51/64	3/8	3/16	25/32	30°	1-7/64

ORDERING EXAMPLES:

GDH-64-12-.1250 Standard gun-drill bushing, inch ID
 GDH-64-12-.1772 Standard gun-drill bushing, mm ID (.1772 = 4.50mm)

STANDARD ID TOLERANCES:

1/8 to 1-1/16" -0.000/+0.002 | 3 to 27mm -0.00/+0.005mm

TYPE GDH — ONE-PIECE DEHOFF TYPE

ID RANGE	OD	LENGTH	PART NO.	LOCK SCREW
.1250-.7812	1 1.0000-.9998	3/4	GDH-64-12	LS-2
1/8-25/32		1	GDH-64-16	
3.20-19.50mm		1-3/8	GDH-64-22	
.1250-1.0625	1-3/8 1.3750-1.3747	1	GDH-88-16	LS-2
1/8-1-1/16		1-3/8	GDH-88-22	
3.20-27.00mm				

AIR FEED BUSHINGS



ADAPTOR TIP ASSEMBLY

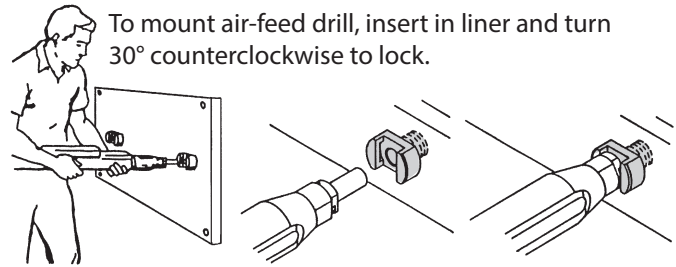
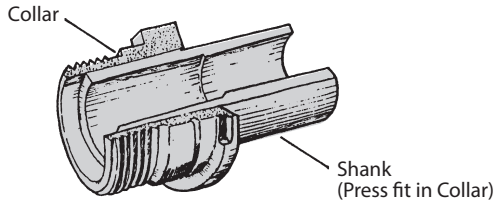

To mount air-feed drill, insert in liner and turn 30° counterclockwise to lock.

STANDARD AIR-FEED DRILLS

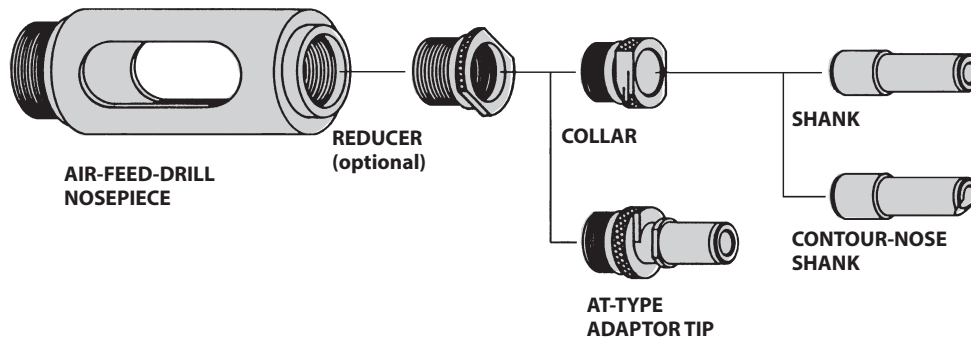

COOLANT-TYPE AIR-FEED DRILLS

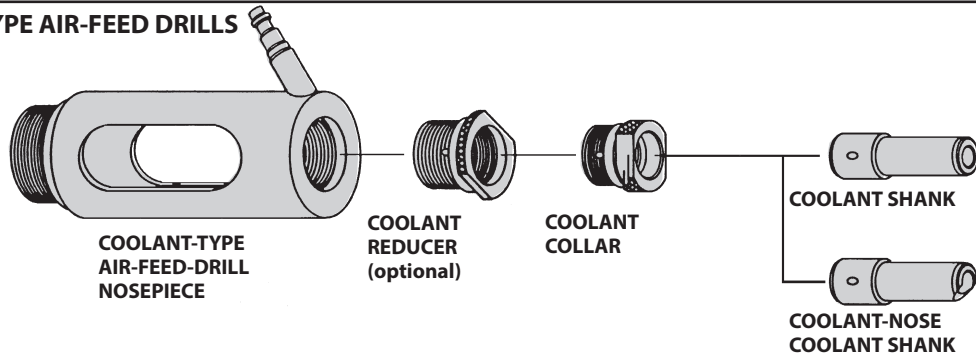

MOUNTING OPTIONS

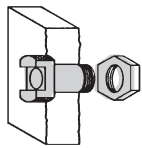

TAPER-LOK LINERS

New-design one-piece lock liner has angular locking surfaces for superior strength. Allows very close hole spacing. Hold in place with a lock nut. Also available knurled for installing in plastic tooling.

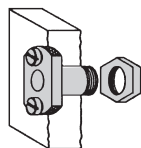

LOCK LINERS

Conventional lock liner incorporating two lock screws. Hold in place with a lock nut.

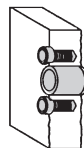

TAPER-LOK AIR-FEED LOCKSCREWS

New-design lock screw especially for air-feed drills. Angular locking surface for superior strength. Install two lock screws and a liner directly in jig plate.

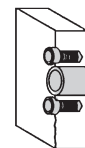

LOCKSCREWS

Conventional-style lock screws. Install two lock screws and a liner bushing directly in jig plate.

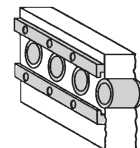

LOCK STRIPS

Allows the closest possible hole spacing. Use together with liner bushings.

AIR FEED BUSHINGS

APPLICATIONS:

Drill-bush shanks, collars, adaptors, and locking accessories for air-feed drills, tappers, and back-spotfacers. Available for all standard drill motors, including Gardner-Denver, Keller, Aro, Buckeye, Quackenbush, Desoutter, and Ingersoll-Rand.

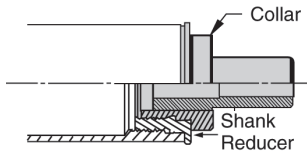

CONSTRUCTION:

Adaptor-tip assemblies consist of two pieces: a locking collar and a pressed-in shank. The collar screws into the air-feed-drill nosepiece, precisely aligns the shank, and locks the drill in place by rotating 30° counter-clockwise after mounting. Shanks and collars can be ordered separately for replacement purposes.

ORDERING EXAMPLES:

A-21101-.1250	Complete adaptor-tip assembly
21101-.1250	Shank only
21000	Collar only
A-21101-.1250-C	Complete assembly with contour nose
21101-.1250-C	Shank only, with contour nose
A-11101-.1250	Coolant-type assembly
A-11101-.1250-C	Coolant-type assembly with contour nose

Standard prices apply only to bushings with a standard-drill-size ID within the stated ID range. See catalog back cover for standard drill sizes and their decimal equivalents. For prices on non-standard ID sizes, including reamer-tolerance and tap-guide bushings, please contact factory.

STANDARD ID TOLERANCES:

From #70 to 1/4"	+0.001/+0.004	From 1 to 3mm	+0.002/+0.008mm
Over 1/4 to 3/4"	+0.001/+0.005	Over 3 to 6mm	+0.004/+0.012mm
Over 3/4 to 1-1/2"	+0.002/+0.006	Over 6 to 10mm	+0.005/+0.014mm
		Over 10 to 18mm	+0.006/+0.017mm
AT-Type	+0.000/+0.003	Over 18 to 30mm	+0.007/+0.020mm

OPTIONAL COOLANT TYPE:

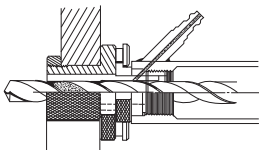

For coolant-inducing air-feed drills. Special shanks, collars, and reducers with internal coolant passages. Contact factory for pricing.

OPTIONAL CONTOUR NOSE:

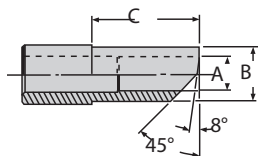

Angular-nose shank recommended for close drilling along sloped or curved surfaces. Available on standard and coolant-type shanks. To order, add "-C" suffix to part number. Contact factory for pricing.

ADAPTOR TIP ASSEMBLIES

21000 SERIES

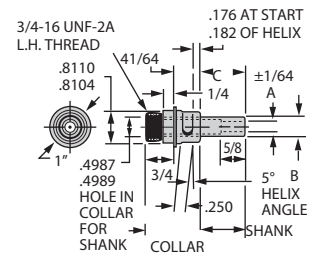

22000 SERIES

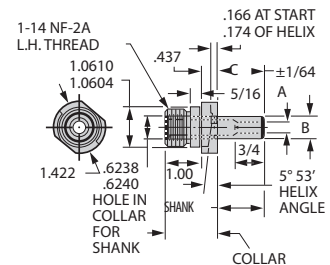

23000 SERIES

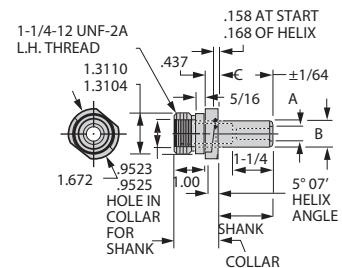

24000 SERIES

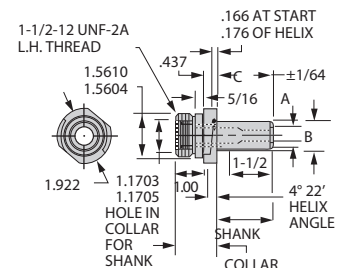

25000 SERIES

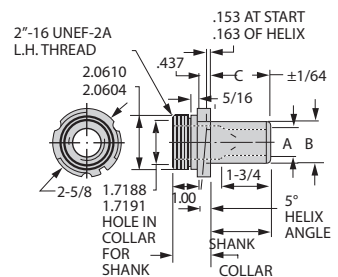

AIR FEED BUSHINGS



21000 SERIES

A ID RANGE	B OD	C LENGTH	TIP ASSEMBLY		SHANK ONLY		COLLAR ONLY		TAPER-LOK LINER PART NO.	LOCK LINER PART NO.	LOCK NUT PART NO.	TAPER-LOK LOCKSCREW PART NO.	LOCK SCREW PART NO.	LINER PART NO.										
			STANDARD TYPE PART NO.	COOLANT TYPE PART NO.	STANDARD TYPE PART NO.	COOLANT TYPE PART NO.	STANDARD TYPE PART NO.	COOLANT TYPE PART NO.																
.0938-.2500 3/32-1/4 2.40-6.35mm	3/8 .3748-.3745	3/8	A-21101	A-11101	21101	11101	21000	11000	TLL-16520 (Matches A-21106 tip)	A-16520 (Matches A-16500 tip)	14441			19936										
		1/2	A-21102	A-11102	21102	11102																		
		5/8	A-21103	A-11103	21103	11103																		
		3/4	A-21104	A-11104	21104	11104																		
		7/8	A-21105	A-11105	21105	11105																		
		1	A-21106	A-11106	21106	11106																		
		1-1/16	A-16500	A-11107	16500	11107																		
		1-1/8	A-21108	A-11108	21108	11108																		
		1-1/4	A-21110	A-11110	21110	11110																		
		1-3/8	A-21111	A-11111	21111	11111																		
		1-1/2	A-21113	A-11113	21113	11113																		
		1-5/8	A-21114	A-11114	21114	11114																		
		1-3/4	A-21115	A-11115	21115	11115																		
		1-7/8	A-21116	A-11116	21116	11116																		
		2	A-21118	A-11118	21118	11118																		
		2-1/8	A-21119	A-11119	21119	11119																		
		2-1/4	A-21120	A-11120	21120	11120																		
		2-3/8	A-21121	A-11121	21121	11121																		
		2-1/2	A-21122	A-11122	21122	11122																		
		2-3/4	A-21124	A-11124	21124	11124																		
		3	A-21125	A-11125	21125	11125																		
		3-1/4	A-21126	A-11126	21126	11126																		
		6	A-21131	A-11131	21131	11131																		
		.0938-.3125 3/32-5/16 2.40-7.90mm	7/16 .4373-.4370	1/2	A-21202	A-11202									21202	11202	21000	11000				CL-11-AFL or CL-13-AFL or CL-14-AFL	16531	19937
				5/8	A-21203	A-11203									21203	11203								
				3/4	A-21204	A-11204									21204	11204								
				7/8	A-21205	A-11205									21205	11205								
				1	A-21206	A-11206									21206	11206								
1-1/8	A-21208			A-11208	21208	11208																		
1-1/4	A-21210			A-11210	21210	11210																		
1-3/8	A-21211			A-11211	21211	11211																		
1-1/2	A-21213			A-11213	21213	11213																		
1-5/8	A-21214			A-11214	21214	11214																		
1-3/4	A-21215			A-11215	21215	11215																		
1-7/8	A-21216			A-11216	21216	11216																		
2	A-21218			A-11218	21218	11218																		
2-1/8	A-21219			A-11219	21219	11219																		
2-1/4	A-21220			A-11220	21220	11220																		
2-3/8	A-21221			A-11221	21221	11221																		
2-1/2	A-21222			A-11222	21222	11222																		
2-3/4	A-21224			A-11224	21224	11224																		
3	A-21225			A-11225	21225	11225																		
3-1/4	A-21226			A-11226	21226	11226																		
.0938-.3750 3/32-3/8 2.40-9.50mm	1/2 .4998-.4995			3/8	A-21301	A-11301	21301	11301	21000	11000	TLL-16521 (Matches A-21306 tip)	A-16521 (Matches A-16501 tip)	14442			19938								
				1/2	A-21302	A-11302	21302	11302																
				5/8	A-21303	A-11303	21303	11303																
				3/4	A-21304	A-11304	21304	11304																
				7/8	A-21305	A-11305	21305	11305																
				1	A-21306	A-11306	21306	11306																
				1-1/16	A-16501	A-11307	16501	11307																
				1-1/8	A-21308	A-11308	21308	11308																
		1-1/4	A-21310	A-11310	21310	11310																		
		1-3/8	A-21311	A-11311	21311	11311																		
		1-1/2	A-21313	A-11313	21313	11313																		
		1-5/8	A-21314	A-11314	21314	11314																		
		1-3/4	A-21315	A-11315	21315	11315																		
		1-7/8	A-21316	A-11316	21316	11316																		
		2	A-21318	A-11318	21318	11318																		
		2-1/8	A-21319	A-11319	21319	11319																		
		2-1/4	A-21320	A-11320	21320	11320																		
		2-3/8	A-21321	A-11321	21321	11321																		
		2-1/2	A-21322	A-11322	21322	11322																		
		2-3/4	A-21324	A-11324	21324	11324																		
		3	A-21325	A-11325	21325	11325																		
		3-1/4	A-21326	A-11326	21326	11326																		
		5	A-21330	A-11330	21330	11330																		

AIR FEED BUSHINGS



22000 SERIES

A ID RANGE	B OD	C LENGTH	TIP ASSEMBLY		SHANK ONLY		COLLAR ONLY		TAPER-LOK LINER PART NO.	LOCK LINER PART NO.	LOCK NUT PART NO.	TAPER-LOK LOCKSREW PART NO.	LOCK SCREW PART NO.	LINER PART NO.										
			STANDARD TYPE PART NO.	COOLANT TYPE PART NO.	STANDARD TYPE PART NO.	COOLANT TYPE PART NO.	STANDARD TYPE PART NO.	COOLANT TYPE PART NO.																
.1875-.2812 3/16-9/32 4.80-7.10mm	7/16 .4373-.4370	3/8	A-22101	A-12101	22101	12101	22000	12000				CL-11-AFL or CL-13-AFL or CL-14-AFL		19937										
		1/2	A-22102	A-12102	22102	12102																		
		5/8	A-22103	A-12103	22103	12103																		
		3/4	A-22104	A-12104	22104	12104																		
		7/8	A-22105	A-12105	22105	12105																		
		1	A-22106	A-12106	22106	12106																		
		1-1/8	A-22108	A-12108	22108	12108																		
		1-1/4	A-22110	A-12110	22110	12110																		
		1-3/8	A-22111	A-12111	22111	12111																		
		1-1/2	A-22113	A-12113	22113	12113																		
		1-5/8	A-22114	A-12114	22114	12114																		
		1-3/4	A-22115	A-12115	22115	12115																		
		1-7/8	A-22116	A-12116	22116	12116																		
		2	A-22118	A-12118	22118	12118																		
		2-1/8	A-22119	A-12119	22119	12119																		
		2-1/4	A-22120	A-12120	22120	12120																		
		2-3/8	A-22121	A-12121	22121	12121																		
		2-1/2	A-22122	A-12122	22122	12122																		
		2-3/4	A-22124	A-12124	22124	12124																		
		3	A-22125	A-12125	22125	12125																		
		3-1/4	A-22126	A-12126	22126	12126																		
		3-1/2	A-22127	A-12127	22127	12127																		
		3-3/4	A-22128	A-12128	22128	12128																		
		4	A-22129	A-12129	22129	12129																		
		5	A-22130	A-12130	22130	12130																		
		6	A-22131	A-12131	22131	12131																		
		.1875-.3438 3/16-11/32 4.80-8.70mm	1/2 .4998-.4995	1/2	A-22202	A-12202									22202	12202	22000	12000				CL-11-AFL or CL-13-AFL or CL-14-AFL		19938
				5/8	A-22203	A-12203									22203	12203								
3/4	A-22204			A-12204	22204	12204																		
7/8	A-22205			A-12205	22205	12205																		
1	A-22206			A-12206	22206	12206																		
1-1/8	A-22208			A-12208	22208	12208																		
1-1/4	A-22210			A-12210	22210	12210																		
1-3/8	A-22211			A-12211	22211	12211																		
1-1/2	A-22213			A-12213	22213	12213																		
1-5/8	A-22214			A-12214	22214	12214																		
1-3/4	A-22215			A-12215	22215	12215																		
1-7/8	A-22216			A-12216	22216	12216																		
2	A-22218			A-12218	22218	12218																		
2-1/8	A-22219			A-12219	22219	12219																		
2-1/4	A-22220			A-12220	22220	12220																		
2-3/8	A-22221			A-12221	22221	12221																		
2-1/2	A-22222			A-12222	22222	12222																		
2-3/4	A-22224			A-12224	22224	12224																		
3	A-22225			A-12225	22225	12225																		
3-1/4	A-22226			A-12226	22226	12226																		
3-1/2	A-22227			A-12227	22227	12227																		
3-3/4	A-22228			A-12228	22228	12228																		
4	A-22229			A-12229	22229	12229																		
5	A-22230			A-12230	22230	12230																		
6	A-22231			A-12231	22231	12231																		
.1875-.4062 3/16-13/32 4.80-10.20mm	9/16 .5623-.5620			5/8	A-22303	A-12303	22303	12303	22000	12000				CL-11-AFL or CL-13-AFL or CL-14-AFL		19939								
				3/4	A-22304	A-12304	22304	12304																
				7/8	A-22305	A-12305	22305	12305																
		1	A-22306	A-12306	22306	12306																		
		1-1/8	A-22308	A-12308	22308	12308																		
		1-1/4	A-22310	A-12310	22310	12310																		
		1-3/8	A-22311	A-12311	22311	12311																		
		1-1/2	A-22313	A-12313	22313	12313																		
		1-5/8	A-22314	A-12314	22314	12314																		
		1-3/4	A-22315	A-12315	22315	12315																		
		1-7/8	A-22316	A-12316	22316	12316																		

CONTINUED ON NEXT PAGE

AIR FEED BUSHINGS

22000 SERIES (CONT.)

A ID RANGE	B OD	C LENGTH	TIP ASSEMBLY		SHANK ONLY		COLLAR ONLY		TAPER-LOK LINER PART NO.	LOCK LINER PART NO.	LOCK NUT PART NO.	TAPER-LOK LOCKSCREW PART NO.	LOCK SCREW PART NO.	LINER PART NO.
			STANDARD TYPE PART NO.	COOLANT TYPE PART NO.	STANDARD TYPE PART NO.	COOLANT TYPE PART NO.	STANDARD TYPE PART NO.	COOLANT TYPE PART NO.						
			CONTINUED FROM PRECEDING PAGE.											
.1875-.4062 3/16-13/32 4.80-10.20mm	9/16 .5623-.5620	2	A-22318	A-12318	22318	12318								
		2-1/8	A-22319	A-12319	22319	12319								
		2-1/4	A-22320	A-12320	22320	12320								
		2-3/8	A-22321	A-12321	22321	12321								
		2-1/2	A-22322	A-12322	22322	12322								
		2-3/4	A-22324	A-12324	22324	12324								
		3	A-22325	A-12325	22325	12325								
		3-1/4	A-22326	A-12326	22326	12326								19939
		3-1/2	A-22327	A-12327	22327	12327								
		3-3/4	A-22328	A-12328	22328	12328								
		4	A-22329	A-12329	22329	12329								
		5	A-22330	A-12330	22330	12330								
		6	A-22331	A-12331	22331	12331								
		.1875-.4688 3/16-15/32 4.80-11.80mm	5/8 .6248-.6245	3/8	A-22401	A-12401	22401	12401						
1/2	A-22402			A-12402	22402	12402								
5/8	A-22403			A-12403	22403	12403								
3/4	A-22404			A-12404	22404	12404								
7/8	A-22405			A-12405	22405	12405								
1	A-22406			A-12406	22406	12406								
1-1/8	A-22408			A-12408	22408	12408								
1-3/16	A-16502			A-12409	16502	12409								
1-1/4	A-22410			A-12410	22410	12410								
1-3/8	A-22411			A-12411	22411	12411								
1-1/2	A-22413			A-12413	22413	12413								
1-5/8	A-22414			A-12414	22414	12414								
1-3/4	A-22415			A-12415	22415	12415								
1-7/8	A-22416			A-12416	22416	12416								
2	A-22418			A-12418	22418	12418								
2-1/8	A-22419			A-12419	22419	12419								
2-1/4	A-22420			A-12420	22420	12420								
2-3/8	A-22421			A-12421	22421	12421								
2-1/2	A-22422			A-12422	22422	12422								
2-3/4	A-22424			A-12424	22424	12424								
3	A-22425			A-12425	22425	12425								
3-1/4	A-22426			A-12426	22426	12426								
3-1/2	A-22427			A-12427	22427	12427								
3-3/4	A-22428			A-12428	22428	12428								
4	A-22429	A-12429	22429	12429										
5	A-22430	A-12430	22430	12430										
6	A-22431	A-12431	22431	12431										
.1875-.4688 3/16-15/32 4.80-11.80mm	3/4 .7498-.7495	3/4	A-22504	A-12504	22504	12504								
		7/8	A-22505	A-12505	22505	12505								
		1	A-22506	A-12506	22506	12506								
		1-1/8	A-22508	A-12508	22508	12508								
		1-1/4	A-22510	A-12510	22510	12510								
		1-3/8	A-22511	A-12511	22511	12511								
		1-1/2	A-22513	A-12513	22513	12513								
		1-5/8	A-22514	A-12514	22514	12514								
		1-3/4	A-22515	A-12515	22515	12515								
		1-7/8	A-22516	A-12516	22516	12516								
		2	A-22518	A-12518	22518	12518								
		2-1/8	A-22519	A-12519	22519	12519								
		2-1/4	A-22520	A-12520	22520	12520								
		2-3/8	A-22521	A-12521	22521	12521								
		2-1/2	A-22522	A-12522	22522	12522								
		2-3/4	A-22524	A-12524	22524	12524								
		3	A-22525	A-12525	22525	12525								
		3-1/4	A-22526	A-12526	22526	12526								
		3-1/2	A-22527	A-12527	22527	12527								
		3-3/4	A-22528	A-12528	22528	12528								
		4	A-22529	A-12529	22529	12529								
		5	A-22530	A-12530	22530	12530								
		6	A-22531	A-12531	22531	12531								

AIR FEED BUSHINGS

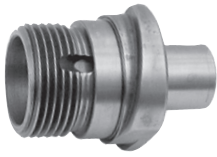

23000 SERIES

A ID RANGE	B OD	C LENGTH	TIP ASSEMBLY		SHANK ONLY		COLLAR ONLY		TAPER-LOK LINER PART NO.	LOCK LINER PART NO.	LOCK NUT PART NO.	TAPER-LOK LOCKSREW PART NO.	LOCK SCREW PART NO.	LINER PART NO.										
			STANDARD TYPE PART NO.	COOLANT TYPE PART NO.	STANDARD TYPE PART NO.	COOLANT TYPE PART NO.	STANDARD TYPE PART NO.	COOLANT TYPE PART NO.																
.2500-.5312 1/4-17/32 6.30-13.50mm	3/4 .7498-.7495	3/4	A-23104	A-13104	23104	13104	23000	13000				CL-11-AFL or CL-13-AFL or CL-14-AFL	16532	19942										
		7/8	A-23105	A-13105	23105	13105																		
		1	A-23106	A-13106	23106	13106																		
		1-1/8	A-23108	A-13108	23108	13108																		
		1-1/4	A-23110	A-13110	23110	13110																		
		1-3/8	A-23111	A-13111	23111	13111																		
		1-1/2	A-23113	A-13113	23113	13113																		
		1-5/8	A-23114	A-13114	23114	13114																		
		1-3/4	A-23115	A-13115	23115	13115																		
		1-7/8	A-23116	A-13116	23116	13116																		
		2	A-23118	A-13118	23118	13118																		
		2-1/8	A-23119	A-13119	23119	13119																		
		2-1/4	A-23120	A-13120	23120	13120																		
		2-3/8	A-23121	A-13121	23121	13121																		
		2-1/2	A-23122	A-13122	23122	13122																		
		2-3/4	A-23124	A-13124	23124	13124																		
		3	A-23125	A-13125	23125	13125																		
		3-1/4	A-23126	A-13126	23126	13126																		
		3-1/2	A-23127	A-13127	23127	13127																		
		3-3/4	A-23128	A-13128	23128	13128																		
		4	A-23129	A-13129	23129	13129																		
		5	A-23130	A-13130	23130	13130																		
		6	A-23131	A-13131	23131	13131																		
		.2500-.5938 1/4-19/32 6.30-15.00mm	13/16 .8123-.8120	3/4	A-23204	A-13204									23204	13204	23000	13000				CL-11-AFL or CL-13-AFL or CL-14-AFL	16532	19943
				7/8	A-23205	A-13205									23205	13205								
				1	A-23206	A-13206									23206	13206								
1-1/8	A-23208			A-13208	23208	13208																		
1-1/4	A-23210			A-13210	23210	13210																		
1-3/8	A-23211			A-13211	23211	13211																		
1-1/2	A-23213			A-13213	23213	13213																		
1-5/8	A-23214			A-13214	23214	13214																		
1-3/4	A-23215			A-13215	23215	13215																		
1-7/8	A-23216			A-13216	23216	13216																		
2	A-23218			A-13218	23218	13218																		
2-1/8	A-23219			A-13219	23219	13219																		
2-1/4	A-23220			A-13220	23220	13220																		
2-3/8	A-23221			A-13221	23221	13221																		
2-1/2	A-23222			A-13222	23222	13222																		
2-3/4	A-23224			A-13224	23224	13224																		
3	A-23225			A-13225	23225	13225																		
3-1/4	A-23226			A-13226	23226	13226																		
3-1/2	A-23227			A-13227	23227	13227																		
3-3/4	A-23228			A-13228	23228	13228																		
4	A-23229			A-13229	23229	13229																		
5	A-23230			A-13230	23230	13230																		
6	A-23231			A-13231	23231	13231																		

CONTINUED ON NEXT PAGE

AIR FEED BUSHINGS

23000 SERIES (CONT.)

A ID RANGE	B OD	C LENGTH	TIP ASSEMBLY		SHANK ONLY		COLLAR ONLY		TAPER-LOK LINER PART NO.	LOCK LINER PART NO.	LOCK NUT PART NO.	TAPER-LOK LOCKSREW PART NO.	LOCK SCREW PART NO.	LINER PART NO.										
			STANDARD TYPE PART NO.	COOLANT TYPE PART NO.	STANDARD TYPE PART NO.	COOLANT TYPE PART NO.	STANDARD TYPE PART NO.	COOLANT TYPE PART NO.																
.2500-.6562 1/4-21/32 6.30-16.50mm	7/8 .8748-.8745	3/4	A-23304	A-13304	23304	13304	23000	13000	TLL-16523 (Matches A-23310 Tip)	A-16523 (Matches A-16504 Tip)	14445			19944										
		7/8	A-23305	A-13305	23305	13305																		
		1	A-23306	A-13306	23306	13306																		
		1-1/8	A-23308	A-13308	23308	13308																		
		1-1/4	A-23310	A-13310	23310	13310																		
		1-3/8	A-23311	A-13311	23311	13311																		
		1-7/16	A-16503	A-13312	16503	13312																		
		1-1/2	A-23313	A-13313	23313	13313																		
		1-5/8	A-23314	A-13314	23314	13314																		
		1-3/4	A-23315	A-13315	23315	13315																		
		1-7/8	A-23316	A-13316	23316	13316																		
		2	A-23318	A-13318	23318	13318																		
		2-1/8	A-23319	A-13319	23319	13319																		
		2-1/4	A-23320	A-13320	23320	13320																		
		2-3/8	A-23321	A-13321	23321	13321																		
		2-1/2	A-23322	A-13322	23322	13322																		
		2-3/4	A-23324	A-13324	23324	13324																		
		3	A-23325	A-13325	23325	13325																		
		3-1/4	A-23326	A-13326	23326	13326																		
		3-1/2	A-23327	A-13327	23327	13327																		
		3-3/4	A-23328	A-13328	23328	13328																		
		4	A-23329	A-13329	23329	13329																		
		5	A-23330	A-13330	23330	13330																		
		6	A-23331	A-13331	23331	13331																		
		.2500-.7188 1/4-23/32 6.30-18.00mm	1 .9998-.9995	1	A-23406	A-13406									23406	13406	23000	13000				CL-11-AFL or CL-13-AFL or CL-14-AFL	16532	19945
				1-1/8	A-23408	A-13408									23408	13408								
				1-1/4	A-23410	A-13410									23410	13410								
				1-3/8	A-23411	A-13411									23411	13411								
				1-1/2	A-23413	A-13413									23413	13413								
				1-5/8	A-23414	A-13414									23414	13414								
1-3/4	A-23415			A-13415	23415	13415																		
1-7/8	A-23416			A-13416	23416	13416																		
2	A-23418			A-13418	23418	13418																		
2-1/8	A-23419			A-13419	23419	13419																		
2-1/4	A-23420			A-13420	23420	13420																		
2-3/8	A-23421			A-13421	23421	13421																		
2-1/2	A-23422			A-13422	23422	13422																		
2-3/4	A-23424			A-13424	23424	13424																		
3	A-23425			A-13425	23425	13425																		
3-1/4	A-23426			A-13426	23426	13426																		
3-1/2	A-23427			A-13427	23427	13427																		
3-3/4	A-23428			A-13428	23428	13428																		
4	A-23429			A-13429	23429	13429																		
5	A-23430			A-13430	23430	13430																		
6	A-23431			A-13431	23431	13431																		
.2500-.7188 5/16-23/32 6.30-18.00mm	1-1/8 1.1248-1.1245	1	A-23506	A-13506	23506	13506	23000	13000	TTL-16524 (Matches A-23515 Tip)	A-16524 (Matches A-16504 Tip)	14446			19946										
		1-1/8	A-23508	A-13508	23508	13508																		
		1-1/4	A-23510	A-13510	23510	13510																		
		1-3/8	A-23511	A-13511	23511	13511																		
		1-1/2	A-23513	A-13513	23513	13513																		
		1-5/8	A-23514	A-13514	23514	13514																		
		1-3/4	A-23515	A-13515	23515	13515																		
		1-7/8	A-23516	A-13516	23516	13516																		
		1-15/16	A-16504	A-13517	16504	13517																		
		2	A-23518	A-13518	23518	13518																		
		2-1/8	A-23519	A-13519	23519	13519																		
		2-1/4	A-23520	A-13520	23520	13520																		
		2-3/8	A-23521	A-13521	23521	13521																		
		2-1/2	A-23522	A-13522	23522	13522																		
		2-3/4	A-23524	A-13524	23524	13524																		
		3	A-23525	A-13525	23525	13525																		
		3-1/4	A-23526	A-13526	23526	13526																		
		3-1/2	A-23527	A-13527	23527	13527																		
		3-3/4	A-23528	A-13528	23528	13528																		
		4	A-23529	A-13529	23529	13529																		
		5	A-23530	A-13530	23530	13530																		
6	A-23531	A-13531	23531	13531																				

AIR FEED BUSHINGS



24000 SERIES

A ID RANGE	B OD	C LENGTH	TIP ASSEMBLY		SHANK ONLY		COLLAR ONLY		TAPER-LOK LINER PART NO.	LOCK LINER PART NO.	LOCK NUT PART NO.	TAPER-LOK LOCKSREW PART NO.	LOCK SCREW PART NO.	LINER PART NO.	
			STANDARD TYPE PART NO.	COOLANT TYPE PART NO.	STANDARD TYPE PART NO.	COOLANT TYPE PART NO.	STANDARD TYPE PART NO.	COOLANT TYPE PART NO.							
.3125-.4062 5/16-13/32 8.00-10.20mm	5/8 .6248-.6245	5/8	A-24103	A-14103	24103	14103									
		3/4	A-24104	A-14104	24104	14104									
		7/8	A-24105	A-14105	24105	14105									
		1	A-24106	A-14106	24106	14106									
		1-1/8	A-24108	A-14108	24108	14108									
		1-1/4	A-24110	A-14110	24110	14110									
		1-3/8	A-24111	A-14111	24111	14111									
		1-1/2	A-24113	A-14113	24113	14113									
		1-5/8	A-24114	A-14114	24114	14114									
		1-3/4	A-24115	A-14115	24115	14115									
		1-7/8	A-24116	A-14116	24116	14116									
		2	A-24118	A-14118	24118	14118									
		2-1/8	A-24119	A-14119	24119	14119									
		2-1/4	A-24120	A-14120	24120	14120								19947	
		2-3/8	A-24121	A-14121	24121	14121									
		2-1/2	A-24122	A-14122	24122	14122									
		2-3/4	A-24124	A-14124	24124	14124									
		3	A-24125	A-14125	24125	14125									
		3-1/4	A-24126	A-14126	24126	14126									
		3-1/2	A-24127	A-14127	24127	14127									
		3-3/4	A-24128	A-14128	24128	14128									
		4	A-24129	A-14129	24129	14129									
		5	A-24130	A-14130	24130	14130	24000					CL-11-AFL or CL-13-AFL or CL-14-AFL			
		6	A-24131	A-14131	24131	14131	14000						16532		
		.3125-.5312 5/16-17/32 8.00-13.50mm	3/4 .7498-.7495	3/4	A-24304	A-14304	24304	14304							
				7/8	A-24305	A-14305	24305	14305							
				1	A-24306	A-14306	24306	14306							
				1-1/8	A-24308	A-14308	24308	14308							
1-1/4	A-24310			A-14310	24310	14310									
1-3/8	A-24311			A-14311	24311	14311									
1-1/2	A-24313			A-14313	24313	14313									
1-5/8	A-24314			A-14314	24314	14314									
1-3/4	A-24315			A-14315	24315	14315									
1-7/8	A-24316			A-14316	24316	14316									
2	A-24318			A-14318	24318	14318									
2-1/8	A-24319			A-14319	24319	14319									
2-1/4	A-24320			A-14320	24320	14320							19949		
2-3/8	A-24321			A-14321	24321	14321									
2-1/2	A-24322			A-14322	24322	14322									
2-3/4	A-24324			A-14324	24324	14324									
3	A-24325			A-14325	24325	14325									
3-1/4	A-24326			A-14326	24326	14326									
3-1/2	A-24327			A-14327	24327	14327									
3-3/4	A-24328			A-14328	24328	14328									
4	A-24329			A-14329	24329	14329									
5	A-24330			A-14330	24330	14330									
6	A-24331			A-14331	24331	14331									

AIR FEED BUSHINGS

24000 SERIES (CONT.)

A ID RANGE	B OD	C LENGTH	TIP ASSEMBLY		SHANK ONLY		COLLAR ONLY		TAPER-LOK LINER PART NO.	LOCK LINER PART NO.	LOCK NUT PART NO.	TAPER-LOK LOCKSREW PART NO.	LOCK SCREW PART NO.	LINER PART NO.	
			STANDARD TYPE PART NO.	COOLANT TYPE PART NO.	STANDARD TYPE PART NO.	COOLANT TYPE PART NO.	STANDARD TYPE PART NO.	COOLANT TYPE PART NO.							
.3125-.6562 5/16-21/32 8.00-16.50mm	7/8 .8745-.8748	7/8	A-24405	A-14405	24405	14405									
		1	A-24406	A-14406	24406	14406									
		1-1/8	A-24408	A-14408	24408	14408									
		1-1/4	A-24410	A-14410	24410	14410									
		1-3/8	A-24411	A-14411	24411	14411									
		1-1/2	A-24413	A-14413	24413	14413									
		1-5/8	A-24414	A-14414	24414	14414									
		1-3/4	A-24415	A-14415	24415	14415									
		1-7/8	A-24416	A-14416	24416	14416									
		2	A-24418	A-14418	24418	14418									
		2-1/8	A-24419	A-14419	24419	14419									
		2-1/4	A-24420	A-14420	24420	14420									19950
		2-3/8	A-24421	A-14421	24421	14421									
		2-1/2	A-24422	A-14422	24422	14422									
		2-3/4	A-24424	A-14424	24424	14424									
		3	A-24425	A-14425	24425	14425									
		3-1/4	A-24426	A-14426	24426	14426									
		3-1/2	A-24427	A-14427	24427	14427									
		3-3/4	A-24428	A-14428	24428	14428									
		4	A-24429	A-14429	24429	14429									
		5	A-24430	A-14430	24430	14430									
6	A-24431	A-14431	24431	14431											
.3125-.7812 5/16-25/32 8.00-19.50mm	1 .9998-.9995	1	A-24506	A-14506	24506	14506									
		1-1/8	A-24508	A-14508	24508	14508									
		1-1/4	A-24510	A-14510	24510	14510									
		1-3/8	A-24511	A-14511	24511	14511									
		1-1/2	A-24513	A-14513	24513	14513									
		1-5/8	A-24514	A-14514	24514	14514									
		1-3/4	A-24515	A-14515	24515	14515									
		1-7/8	A-24516	A-14516	24516	14516									
		2	A-24518	A-14518	24518	14518									
		2-1/8	A-24519	A-14519	24519	14519									
		2-1/4	A-24520	A-14520	24520	14520									
		2-3/8	A-24521	A-14521	24521	14521									
		2-1/2	A-24522	A-14522	24522	14522									
		2-3/4	A-24524	A-14524	24524	14524									
		3	A-24525	A-14525	24525	14525									
		3-1/4	A-24526	A-14526	24526	14526									
		3-1/2	A-24527	A-14527	24527	14527									
		3-3/4	A-24528	A-14528	24528	14528									
		4	A-24529	A-14529	24529	14529									
		5	A-24530	A-14530	24530	14530									
		6	A-24531	A-14531	24531	14531									
.3125-.9062 5/16-29/32 8.00-23.00mm	1-1/8 1.1248-1.1245	1	A-24606	A-14606	24606	14606									
		1-1/8	A-24608	A-14608	24608	14608									
		1-1/4	A-24610	A-14610	24610	14610									
		1-3/8	A-24611	A-14611	24611	14611									
		1-1/2	A-24613	A-14613	24613	14613									
		1-5/8	A-24614	A-14614	24614	14614									
		1-3/4	A-24615	A-14615	24615	14615									
		1-7/8	A-24616	A-14616	24616	14616									
		1-15/16	A-16505	A-14617	16505	14617									
		2	A-24618	A-14618	24618	14618									
		2-1/8	A-24619	A-14619	24619	14619									
		2-1/4	A-24620	A-14620	24620	14620									
		2-3/8	A-24621	A-14621	24621	14621									
		2-1/2	A-24622	A-14622	24622	14622									
		2-3/4	A-24624	A-14624	24624	14624									
		3	A-24625	A-14625	24625	14625									
		3-1/4	A-24626	A-14626	24626	14626									
		3-1/2	A-24627	A-14627	24627	14627									
		3-3/4	A-24628	A-14628	24628	14628									
		4	A-24629	A-14629	24629	14629									
		5	A-24630	A-14630	24630	14630									
6	A-24631	A-14631	24631	14631											

CONTINUED ON NEXT PAGE

AIR FEED BUSHINGS

24000 SERIES (CONT.)

A ID RANGE	B OD	C LENGTH	TIP ASSEMBLY		SHANK ONLY		COLLAR ONLY		TAPER-LOK LINER PART NO.	LOCK LINER PART NO.	LOCK NUT PART NO.	TAPER-LOK LOCKSCREW PART NO.	LOCK SCREW PART NO.	LINER PART NO.										
			STANDARD TYPE PART NO.	COOLANT TYPE PART NO.	STANDARD TYPE PART NO.	COOLANT TYPE PART NO.	STANDARD TYPE PART NO.	COOLANT TYPE PART NO.																
.3125-.9375 5/16-15/16 8.00-23.50mm	1-1/4 1.2498-1.2495	1-1/4	A-24710	A-14710	24710	14710	24000	14000						19952										
		1-3/8	A-24711	A-14711	24711	14711																		
		1-1/2	A-24713	A-14713	24713	14713																		
		1-5/8	A-24714	A-14714	24714	14714																		
		1-3/4	A-24715	A-14715	24715	14715																		
		1-7/8	A-24716	A-14716	24716	14716																		
		2	A-24718	A-14718	24718	14718																		
		2-1/8	A-24719	A-14719	24719	14719																		
		2-1/4	A-24720	A-14720	24720	14720																		
		2-3/8	A-24721	A-14721	24721	14721																		
		2-1/2	A-24722	A-14722	24722	14722																		
		2-3/4	A-24724	A-14724	24724	14724																		
		3	A-24725	A-14725	24725	14725																		
		3-1/4	A-24726	A-14726	24726	14726																		
		3-1/2	A-24727	A-14727	24727	14727																		
		3-3/4	A-24728	A-14728	24728	14728																		
		4	A-24729	A-14729	24729	14729																		
		5	A-24730	A-14730	24730	14730																		
		6	A-24731	A-14731	24731	14731																		
		.3125-.9375 5/16-15/16 8.00-23.50mm	1-1/2 1.4998-1.4995	1	A-24806	A-14806									24806	14806								CL-11-AFL or CL-13-AFL or CL-14-AFL
				1-3/8	A-24811	A-14811									24811	14811								
1-1/2	A-24813			A-14813	24813	14813																		
1-5/8	A-24814			A-14814	24814	14814																		
1-3/4	A-24815			A-14815	24815	14815																		
1-7/8	A-24816			A-14816	24816	14816																		
1-15/16	A-16506			A-14817	16506	14817																		
2	A-24818			A-14818	24818	14818																		
2-1/8	A-24819			A-14819	24819	14819																		
2-1/4	A-24820			A-14820	24820	14820																		
2-3/8	A-24821			A-14821	24821	14821																		
2-1/2	A-24822			A-14822	24822	14822																		
2-3/4	A-24824			A-14824	24824	14824																		
3	A-24825			A-14825	24825	14825																		
3-1/4	A-24826			A-14826	24826	14826																		
3-1/2	A-24827			A-14827	24827	14827																		
3-3/4	A-24828			A-14828	24828	14828																		
4	A-24829			A-14829	24829	14829																		
5	A-24830			A-14830	24830	14830																		
6	A-24831			A-14831	24831	14831																		



25000 SERIES

.3750-1.0312 3/8-1-1/32 9.50-26.00mm	1-1/4 1.2498-1.2495	1-1/4	A-25110	A-15110	25110	15110	25000	15000						CL-12-AFL	16530	19953
		1-3/8	A-25111	A-15111	25111	15111										
		1-1/2	A-25113	A-15113	25113	15113										
		1-5/8	A-25114	A-15114	25114	15114										
		1-3/4	A-25115	A-15115	25115	15115										
		1-7/8	A-25116	A-15116	25116	15116										
		2	A-25118	A-15118	25118	15118										
		2-1/8	A-25119	A-15119	25119	15119										
		2-1/4	A-25120	A-15120	25120	15120										
		2-3/8	A-25121	A-15121	25121	15121										
		2-1/2	A-25122	A-15122	25122	15122										
		2-3/4	A-25124	A-15124	25124	15124										
		3	A-25125	A-15125	25125	15125										
		3-1/4	A-25126	A-15126	25126	15126										
		3-1/2	A-25127	A-15127	25127	15127										
		3-3/4	A-25128	A-15128	25128	15128										
		4	A-25129	A-15129	25129	15129										
		5	A-25130	A-15130	25130	15130										
6	A-25131	A-15131	25211	15131												

AIR FEED BUSHINGS

25000 SERIES (CONT.)

A ID RANGE	B OD	C LENGTH	TIP ASSEMBLY		SHANK ONLY		COLLAR ONLY		TAPER-LOK LINER PART NO.	LOCK LINER PART NO.	LOCK NUT PART NO.	TAPER-LOK LOCKSREW PART NO.	LOCK SCREW PART NO.	LINER PART NO.	
			STANDARD TYPE PART NO.	COOLANT TYPE PART NO.	STANDARD TYPE PART NO.	COOLANT TYPE PART NO.	STANDARD TYPE PART NO.	COOLANT TYPE PART NO.							
.3750-1.1562 3/8-1-5/32 9.50-29.00mm	1-3/8 1.3748-1.3745	1-3/8	A-25211	A-15211	25213	15211									
		1-1/2	A-25213	A-15213	25214	15213									
		1-5/8	A-25214	A-15214	25215	15214									
		1-3/4	A-25215	A-15215	25216	15215									
		1-7/8	A-25216	A-15216	25218	15216									
		2	A-25218	A-15218	25219	15218									
		2-1/8	A-25219	A-15219	25220	15219									
		2-1/4	A-25220	A-15220	25221	15220									
		2-3/8	A-25221	A-15221	25222	15221									
		2-1/2	A-25222	A-15222	25224	15222									
		2-3/4	A-25224	A-15224	25225	15224									
		3	A-25225	A-15225	25226	15225									
		3-1/4	A-25226	A-15226	25227	15226									
		3-1/2	A-25227	A-15227	25228	15227									
		3-3/4	A-25228	A-15228	25229	15228									
		4	A-25229	A-15229	25230	15229									
		5	A-25230	A-15230	25231	15230									
		6	A-25231	A-15231	25313	15231									
.3750-1.2812 3/8-1-9/32 9.50-32.00mm	1-1/2 1.4998-1.4995	1-1/2	A-25313	A-15313	25314	15313									
		1-5/8	A-25314	A-15314	25315	15314									
		1-3/4	A-25315	A-15315	25316	15315									
		1-7/8	A-25316	A-15316	25318	15316									
		2	A-25318	A-15318	25319	15318									
		2-1/8	A-25319	A-15319	25320	15319									
		2-1/4	A-25320	A-15320	25321	15320									
		2-3/8	A-25321	A-15321	25322	15321									
		2-1/2	A-25322	A-15322	25324	15322									
		2-3/4	A-25324	A-15324	25325	15324									
		3	A-25325	A-15325	25326	15325									
		3-1/4	A-25326	A-15326	25327	15326									
		3-1/2	A-25327	A-15327	25328	15327									
		3-3/4	A-25328	A-15328	25329	15328									
		4	A-25329	A-15329	25330	15329									
		5	A-25330	A-15330	25331	15330									
		6	A-25331	A-15331	25415	15331									
		.3750-1.4688 3/8-1-15/32 9.50-37.00mm	1-3/4 1.7498-1.7495	1-3/4	A-25415	A-15415	25416	15415							
1-7/8	A-25416			A-15416	25418	15416									
2	A-25418			A-15418	25419	15418									
2-1/8	A-25419			A-15419	25420	15419									
2-1/4	A-25420			A-15420	25421	15420									
2-3/8	A-25421			A-15421	25422	15421									
2-1/2	A-25422			A-15422	25424	15422									
2-3/4	A-25424			A-15424	25425	15424									
3	A-25425			A-15425	25426	15425									
3-1/4	A-25426			A-15426	25427	15426									
3-1/2	A-25427			A-15427	25428	15427									
3-3/4	A-25428			A-15428	25429	15428									
4	A-25429			A-15429	25430	15429									
5	A-25430			A-15430	25431	15430									
6	A-25431			A-15431	25518	15431									
2	A-25518			A-15518	16513	15518									
.3750-1.4688 3/8-1-15/32 9.50-37.00mm	2 1.9998-1.9995			2-5/8	A-16513	A-15523	25524	15523							
				2-3/4	A-25524	A-15524	25525	15524							
		3	A-25525	A-15525	25526	15525									
		3-1/4	A-25526	A-15526	25527	15526									
		3-1/2	A-25527	A-15527	25528	15527									
		3-3/4	A-25528	A-15528	25529	15528									
		4	A-25529	A-15529	25530	15529									
		5	A-25530	A-15530	25531	15530									
6	A-25531	A-15531		15531											

AIR FEED BUSHINGS

AT-TYPE ONE-PIECE ADAPTER TIPS

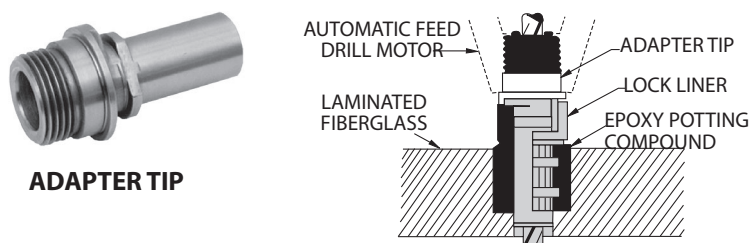

ADAPTER TIP

AT-series adapter tips are one-piece adapters primarily for fiberglass and plastic tooling. They are used with AT-series knurled liners, and are not compatible with any other liners or air-feed accessories. AT-series bushings are available in 3/4-16 and 1"-14 mounting-thread sizes, in a total of four OD sizes, to fit drill diameters from .1910" to .6250".

AT-TYPE ADAPTER TIPS

PART NO.	A ID RANGE	B OD	C	D	L.H. THREAD
AT-1	.1910-.2055 #11-#5	11/32 .3437-.3435	2-7/16	1-9/16	3/4-16
AT-2	.1910-.2850 #11-9/32	7/16 .4375-.4373			
AT-3	.2810-.4130 K-Z	9/16 .5625-.5623			
AT-4	.2810-.6250 K-5/8	3/4 .7500-.7498			1-14



LOCK LINER

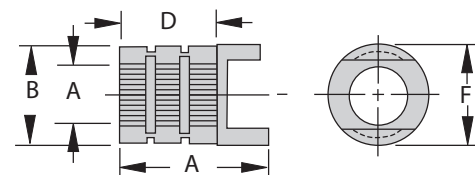

Precision knurled liner bushing for mounting air-feed drills in fiberglass or plastic tooling. AT-series knurled lock liners are designed especially for AT-series one-piece adapter tips, and are not compatible with any other liners or air-feed accessories. Press-fit AT-series liners are available as specials. Available in four sizes.

AT-TYPE LOCK LINERS

PART NO.	A ID RANGE	B OD	C	D	F DIA
LL-1	11/32 .3440-.3443	9/16	1-3/8	7/8	11/16
LL-2	7/16 .4377-.4380	11/16			13/16
LL-3	9/16 .5627-.5630	13/16			15/16
LL-4	3/4 .7503-.7506	1			1-1/8

AIR FEED BUSHINGS

MOUNTING DIMENSIONS FOR LOCKSCREWS AND LOCK STRIPS

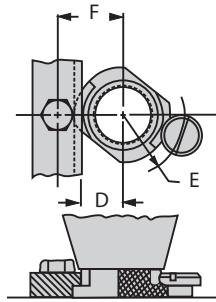

DIMENSION	21000 SERIES	22000 SERIES	23000 SERIES	24000 SERIES	25000 SERIES
D	.312	.609	.734	.859	—
E	.625	.922	1.047	1.172	1.562
F	.687	.984	1.109	1.234	—

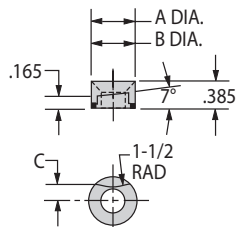

TAPER-LOK AIR-FEED LOCKSCREWS

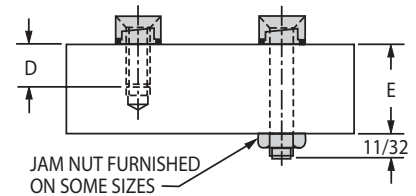

Angular locking surface mates perfectly with air-feed collars. Use instead of standard lock screws for greater strength . . . eliminates worn, bent, or broken lock screws caused by point contact. Serrations at bottom bite into the fixture plate to positively prevent rotation under heavy torque loads. Alloy steel mounting screws furnished. **Patent no. 3,336,822.**

PART NO.	MOUNTING SCREW DIA.	MOUNTING SCREW	A DIA	B DIA	C	D	E	REPLACES STANDARD LOCKSCREW
CL-9-AFL	5/16	Not Furnished	5/8	19/32	3/16	—	—	—
CL-11-AFL		5/16-18x1.00				19/32	—	16531 & 16532
CL-13-AFL		5/16-18x1.50 w/Jam Nut				1-3/32	3/4	—
CL-14-AFL		5/16-18x2.00 w/Jam Nut				1-19/32	1-1/4	—
CL-10-AFL	3/8	Not Furnished	3/4	23/32	7/32	—	—	—
CL-12-AFL		3/8-16x1.00				19/32	—	16530

LOCKSCREWS

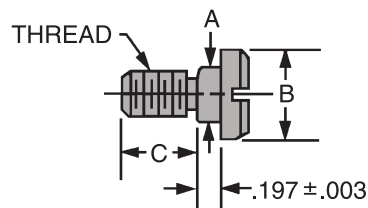

PART NO. (PACK OF 5)	A DIA	B DIA	C	B THREAD
16531-PACKOF5	3/8	5/8	5/16	5/16-18
16532-PACKOF5			7/16	
16530-PACKOF5	7/16	3/4	5/8	3/8-16

LINERS

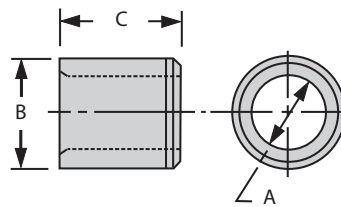

PART NO.	A ID	B OD	C LENGTH
19936	3/8	5/8	1
19937	7/16	3/4	1
19938	1/2		
19939	9/16	7/8	1
19940	5/8		1-3/4
19941		1	
19942	3/4	1	1-3/8
19949			1-3/4
19943	13/16	1-3/8	1-3/8
19944	7/8		1-3/4
19950			1-3/8
19945	1		1-3/4
19951			1-3/4
19946	1-1/8	1-3/4	1-3/4
19952	1-1/4		2-1/2
19953	1-3/8		
19954	1-1/2	2-1/4	2-1/2
19955	1-3/4		
19956			

LOCK STRIPS

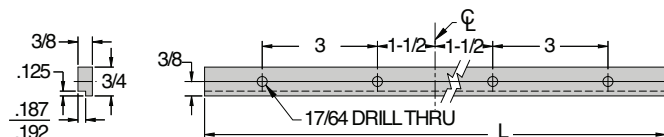
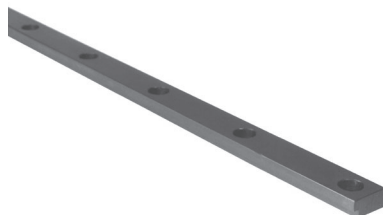

PART NO.	L OVERALL LENGTH	NO. OF HOLES
LSM-12	12	4
LSM-24	24	8
LSM-36	36	12

AIR FEED BUSHINGS

TAPER-LOK LINERS



PRESS FIT

Precision liner bushing for mounting air-feed drills through a jig plate. One-piece design has two angled locking surfaces to lock the drill motor in place, for superior strength. Milled flats allow close hole spacing. Press fit into jig plate, then fasten from behind with a Lock Nut (order separately). Optional heavy-duty type has precisely machined helical locking surfaces that mate exactly with the air-feed collar for added impact resistance. **Patent no. 3,015,242.** Available for 21000 through 24000 series air-feed drills (not 25000 series).

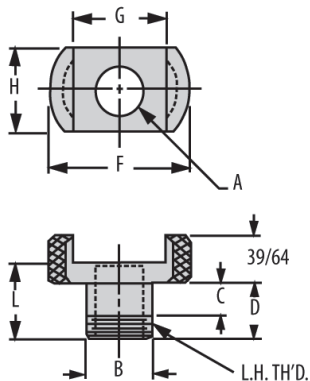

PRESS FIT – STANDARD

PART NO.	A DIA	B DIA	C	D	F DIA	G	H	L	L.H. THREAD	MATCHING LOCK NUT	MATCHING ADAPTOR TIP
TLL-16520	.3750 .3755	.4995 .4990	7/16	3/4	1-1/8	.625	3/4	1	1/2-20	14441	A-21106
TLL-16521	.5000 .5005	.7495 .7490	7/16	3/4	1-3/16	.625	7/8	1	3/4-16	14442	A-21306
TLL-16522	.6250 .6255	.8745 .8740	7/16	3/4	1-13/16	1.218	1-1/8	1	7/8-14	14443	A-22406
TLL-16523	.8750 .8756	1.2495 1.2490	9/16	1	2-1/8	1.468	1-3/8	1-1/4	1-1/4-12	14445	A-23310
TLL-16524	1.1252 1.1258	1.4990 1.4985	27/32	1-1/2	2-1/8	1.468	1-5/8	1-3/4	1-1/2-12	14446	A-23515
TLL-16525	1.1252 1.1258	1.4990 1.4985			2-7/16						1.718
TLL-16526	1.5002 1.5008	1.9990 1.9985	27/32	1-1/2	2-7/16	1.718	2-1/2	1-3/4	2"-16	14447	A-24815

PRESS FIT – HEAVY DUTY

PART NO.	A DIA	B DIA	C	D	F DIA	G	H	L	L.H. THREAD	MATCHING LOCK NUT	MATCHING ADAPTOR TIP
HLL-16520	.3750 .3755	.4995 .4990	7/16	3/4	1-1/8	.625	3/4	1	1/2-20	14441	A-21106
HLL-16521	.5000 .5005	.7495 .7490	7/16	3/4	1-3/16	.625	7/8	1	3/4-16	14442	A-21306
HLL-16522	.6250 .6255	.8745 .8740	7/16	3/4	1-13/16	1.218	1-1/8	1	7/8-14	14443	A-22406
HLL-16523	.8750 .8756	1.2495 1.2490	9/16	1	2-1/8	1.468	1-3/8	1-1/4	1-1/4-12	14445	A-23310
HLL-16524	1.1252 1.1258	1.4990 1.4985	27/32	1-1/2	2-1/8	1.468	1-5/8	1-3/4	1-1/2-12	14446	A-23515
HLL-16525	1.1252 1.1258	1.4990 1.4985			2-7/16						1.718
HLL-16526	1.5002 1.5008	1.9990 1.9985	27/32	1-1/2	2-7/16	1.718	2-1/2	1-3/4	2"-16	14447	A-24815



KNURLED

Precision knurled liner bushing for mounting air-feed drills in fiberglass or plastic tooling. One-piece design has two angled locking surfaces to lock the drill motor in place, for superior strength. Optional heavy-duty type has precisely machined helical locking surfaces that mate exactly with the air-feed collar for added impact resistance. Milled flats allow close hole spacing. Available for 21000 and 22000 series air-feed drills. **Patent no. 3,015,242.**

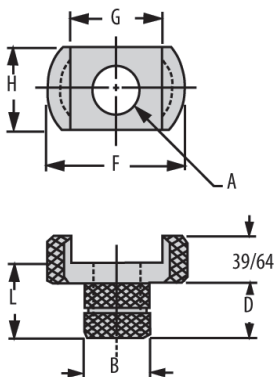

KNURLED – STANDARD

PART NO.	A DIA	B DIA	D	F DIA	G	H	L	MATCHING ADAPTOR TIP
TLD-375	.3750 .3755	3/4	7/8	1-3/16	.625	7/8	1-1/8	A-21108
TLD-500	.5000 .5005	3/4	7/8	1-3/16	.625	7/8	1-1/8	A-21308
TLD-750	.7500 .7505	1-1/8	7/8	1-13/16	1.218	1-1/8	1-1/8	A-22508

KNURLED – HEAVY DUTY

PART NO.	A DIA	B DIA	D	F DIA	G	H	L	MATCHING ADAPTOR TIP
HLD-375	.3750 .3755	3/4	7/8	1-3/16	.625	7/8	1-1/8	A-21108
HLD-500	.5000 .5005	3/4	7/8	1-3/16	.625	7/8	1-1/8	A-21308
HLD-750	.7500 .7505	1-1/8	7/8	1-13/16	1.218	1-1/8	1-1/8	A-22508

AIR FEED BUSHINGS

LOCK LINERS

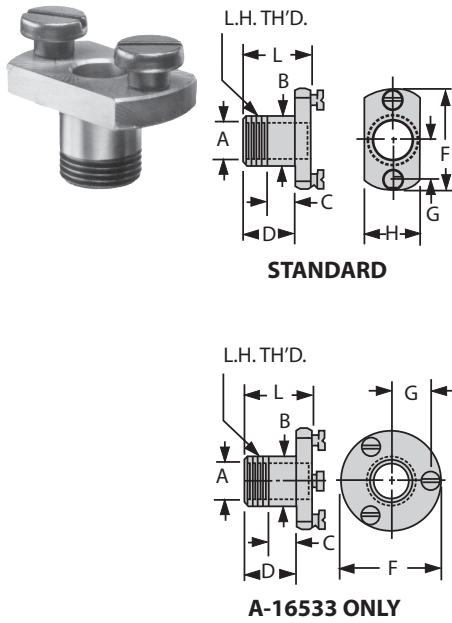

Precision liner bushing for mounting air-feed drills through a jig plate. The large head holds two standard Lockscrews, to lock the drill motor in place. Milled flats allow close hole spacing. Press fit into jig plate, then fasten from behind with a Lock Nut (order separately). Available for 21000 through 25000 series air-feed drills.

PART NO.	A DIA	B DIA	C	D	F DIA	G	H	L	L.H. THREAD	MATCHING LOCK NUT	MATCHING ADAPTOR TIP
.3750	.3750	.4995	7/16	3/4	1-3/4	5/8	3/4	1-1/16	1/2-20	14441	A-16500
	.3756	.4989									
.5000	.5000	.7495	7/16	3/4	1-3/4	5/8	1	1-1/16	3/4-16	14442	A-16501
	.5006	.7489									
.6250	.6250	.8745	7/16	3/4	2-7/16	59/64	1-1/8	1-3/16	7/8-14	14443	A-16502
	.6256	.8739									
.8750	.8750	1.2495	9/16	1	2-11/16	1-3/64	1-1/2	1-7/16	1-1/4-12	14445	A-16503
	.8756	1.2485									
1.1250	1.1250	1.4990	27/32	1-1/2	2-11/16	1-3/64	1-3/4	1-15/16	1-1/2-12	14446	A-16504
	1.1260	1.4980									
1.1250	1.1250	1.4990	27/32	1-1/2	3	1-11/64	1-3/4	1-15/16	1-1/2-12	14446	A-16505
	1.1260	1.4980									
1.5000	1.5000	1.9990	27/32	1-1/2	3	1-11/64	2-1/2	1-15/16	2"-16	14447	A-16506
	1.5010	1.9980									
2.0000	2.0000	2.4990	1-3/8	2	3-3/4	1-9/16	—	2-5/8	2-1/2-16	14448	A-16513
	2.0015	2.4980									

LOCK NUTS

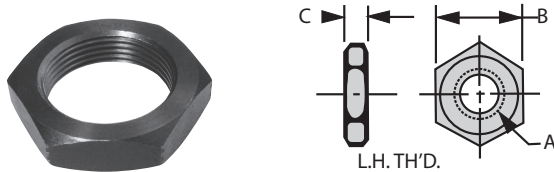

These fine-thread Lock Nuts fit the entire range of standard lock liners. Lock Liners press fit into the jig plate, then fasten from behind with a Lock Nut.

LOCK NUT PART NO.	A (THREAD SIZE)	B	C
14441	1/2-20	3/4	1/4
14442	3/4-16	1	1/4
14443	7/8-14	1-1/4	1/4
14445	1-1/4-12	1-3/4	3/8
14446	1-1/2-12	2	1/2
14447	2-16	2-1/2	1/2
14448	2-1/2-16	3	1/2

REDUCERS

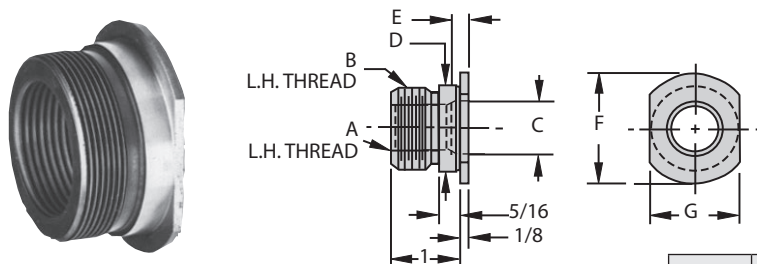

These Reducers allow mounting a smaller-series air-feed adaptor tip on a larger-series drill motor. Available for either standard or coolant-type air-feed drills. Available for 22000 through 25000 series air-feed drill motors. Two Reducers can be used together to step down several sizes.

PART NO. STANDARD TYPE	PART NO. COOLANT TYPE	A INSIDE THREAD	B OUTSIDE THREAD	C DIA	D DIA	E	F DIA	G*
17952	A-17952		1-14		1.0610-1.0604		1-3/8	1-1/16
25018	A-25018	3/4-16	1-1/4-12	.8125	1.3110-1.3104	9/32	1-5/8	1-5/16
25582	A-25582		1-1/2-12		1.5610-1.5604		1-15/16	1-9/16
25583	A-25583	1-1/4	1-1/4-12	1.0625	1.3110-1.3104	11/32	1-5/8	1-5/16
20132	A-20132		1-1/2-12		1.5610-1.5604		1-15/16	1-9/16
20017	A-20017	1-1/4-12	1-1/2-12	1.3125	1.5610-1.5604	11/32	1-15/16	1-9/16
27910	A-27910	1-1/2-12	2-16	1.5625	2.0610-2.0604	11/32	2-1/2	2-1/16

* Coolant type does not have wrench flats.

INCH DRILL SIZES

Drill/Decimal	Drill/Decimal	Drill/Decimal
80 .0135	9/64 .1406	23/64 .3594
79 .0145	27 .1440	U .3680
1/64 .0156	26 .1470	3/8 .3750
78 .0160	25 .1495	V .3770
77 .0180	24 .1520	W .3860
76 .0200	23 .1540	25/64 .3906
75 .0210	5/32 .1562	X .3970
74 .0225	22 .1570	Y .4040
73 .0240	21 .1590	13/32 .4062
72 .0250	20 .1610	Z .4130
71 .0260	19 .1660	27/64 .4219
70 .0280	18 .1695	7/16 .4375
69 .0292	11/64 .1719	29/64 .4531
68 .0310	17 .1730	15/32 .4688
1/32 .0312	16 .1770	31/64 .4844
67 .0320	15 .1800	1/2 .5000
66 .0330	14 .1820	33/64 .5156
65 .0350	13 .1850	17/32 .5312
64 .0360	3/16 .1875	35/64 .5469
63 .0370	12 .1890	9/16 .5625
62 .0380	11 .1910	37/64 .5781
61 .0390	10 .1935	19/32 .5938
60 .0400	9 .1960	39/64 .6094
59 .0410	8 .1990	5/8 .6250
58 .0420	7 .2010	41/64 .6406
57 .0430	13/64 .2031	21/32 .6562
56 .0465	6 .2040	43/64 .6719
3/64 .0469	5 .2055	11/16 .6875
55 .0520	4 .2090	45/64 .7031
54 .0550	3 .2130	23/32 .7188
53 .0595	7/32 .2188	47/64 .7344
1/16 .0625	2 .2210	3/4 .7500
52 .0635	1 .2280	49/64 .7656
51 .0670	A .2340	25/32 .7812
50 .0700	15/64 .2344	51/64 .7969
49 .0730	B .2380	13/16 .8125
48 .0760	C .2420	53/64 .8281
5/64 .0781	D .2460	27/32 .8438
47 .0785	E .2500	55/64 .8594
46 .0810	1/4 .2500	7/8 .8750
45 .0820	F .2570	57/64 .8906
44 .0860	G .2610	29/32 .9062
43 .0890	17/64 .2656	59/64 .9219
42 .0935	H .2660	15/16 .9375
3/32 .0938	I .2720	61/64 .9531
41 .0960	J .2770	31/32 .9688
40 .0980	K .2810	63/64 .9844
39 .0995	9/32 .2812	1 .10000
38 .1015	L .2900	
37 .1040	M .2950	+64th increments up to 1-7/8"
36 .1065	19/64 .2969	
7/64 .1094	N .3020	
35 .1100	5/16 .3125	
34 .1110	O .3160	+32nd increments up to 2-1/4"
33 .1130	P .3230	
32 .1160	21/64 .3281	
31 .1200	Q .3320	
1/8 .1250	R .3390	+16th increments up to 4-1/4"
30 .1285	11/32 .3438	
29 .1360	S .3480	
28 .1405	T .3580	

METRIC DRILL SIZES

Drill/Decimal	Drill/Decimal	Drill/Decimal
.35mm .0138	3.60mm .1417	8.70mm .3425
.38mm .0150	3.70mm .1457	8.75mm .3445
.40mm .0157	3.75mm .1476	8.80mm .3465
.42mm .0165	3.80mm .1496	8.90mm .3504
.45mm .0177	3.90mm .1535	9.00mm .3543
.48mm .0189	4.00mm .1575	9.10mm .3583
.50mm .0197	4.10mm .1614	9.20mm .3622
.55mm .0217	4.20mm .1654	9.25mm .3642
.60mm .0236	4.25mm .1673	9.30mm .3661
.65mm .0256	4.30mm .1693	9.40mm .3701
.70mm .0276	4.40mm .1732	9.50mm .3740
.75mm .0295	4.50mm .1772	9.60mm .3780
.80mm .0315	4.60mm .1811	9.70mm .3819
.85mm .0335	4.70mm .1850	9.75mm .3839
.90mm .0354	4.75mm .1870	9.80mm .3858
.95mm .0374	4.80mm .1890	9.90mm .3898
1.00mm .0394	4.90mm .1929	10.00mm .3937
1.05mm .0413	5.00mm .1969	10.20mm .4016
1.10mm .0433	5.10mm .2008	10.50mm .4134
1.15mm .0453	5.20mm .2047	10.80mm .4252
1.20mm .0472	5.25mm .2067	11.00mm.4331
1.25mm .0492	5.30mm .2087	11.20mm .4409
1.30mm .0512	5.40mm .2126	11.50mm .4528
1.35mm .0531	5.50mm .2165	11.80mm .4646
1.40mm .0551	5.60mm .2205	12.00mm .4724
1.45mm .0571	5.70mm .2244	12.20mm .4803
1.50mm .0591	5.75mm .2264	12.50mm .4921
1.55mm .0610	5.80mm .2283	13.00mm .5118
1.60mm .0630	5.90mm .2323	13.50mm .5315
1.65mm .0650	6.00mm .2362	14.00mm .5512
1.70mm .0669	6.10mm .2402	14.50mm .5709
1.75mm .0689	6.20mm .2441	15.00mm .5906
1.80mm .0709	6.25mm .2461	15.50mm .6102
1.85mm .0728	6.30mm .2480	16.00mm .6299
1.90mm .0748	6.40mm .2520	16.50mm .6496
1.95mm .0768	6.50mm .2559	17.00mm .6693
2.00mm .0787	6.60mm .2598	17.50mm .6890
2.05mm .0807	6.70mm .2638	18.00mm .7087
2.10mm .0827	6.75mm .2657	18.50mm .7283
2.15mm .0846	6.80mm .2677	19.00mm .7480
2.20mm .0866	6.90mm .2717	19.50mm .7677
2.25mm .0886	7.00mm .2756	20.00mm .7874
2.30mm .0906	7.10mm .2795	20.50mm .8071
2.35mm .0925	7.20mm .2835	21.00mm .8268
2.40mm .0945	7.25mm .2854	21.50mm .8465
2.45mm .0965	7.30mm .2874	22.00mm .8661
2.50mm .0984	7.40mm .2913	22.50mm .8858
2.55mm .1004	7.50mm .2953	23.00mm .9055
2.60mm .1024	7.60mm .2992	23.50mm .9252
2.65mm .1043	7.70mm .3031	24.00mm .9449
2.70mm .1063	7.75mm .3051	24.50mm .9646
2.75mm .1083	7.80mm .3071	25.00mm.9843
2.80mm .1102	7.90mm .3110	
2.90mm .1142	8.00mm .3150	+1.00mm increments up to 48mm
3.00mm .1181	8.10mm .3189	
3.10mm .1220	8.20mm .3228	
3.20mm .1260	8.25mm .3248	
3.25mm .1280	8.30mm .3268	+5.00mm increments from 50mm up to 105mm
3.30mm .1299	8.40mm .3307	
3.40mm .1339	8.50mm .3346	
3.50mm .1378	8.60mm .3386	

TAP GUIDE SIZES

(Priced as specials)

Tap Size*	Tap Guide Nominal ID Size	Tap Drill Size**
#0-80	.0616	3/64
#2-56	.0883	#50
#2-64	.0880	#50
#4-40	.1152	#43
#4-48	.1147	#42
#5-40	.1282	#38
#5-44	.1280(3.25mm)	#37
#6-32	.1421	#36
#6-40	.1412	#33
#8-32	.1681	#29
#8-36	.1676	#29
#10-24	.1954	#25
#10-32	.1941	#21
1/4-20	.2565	#7
1/4-28	.2546	#3
5/16-18	.3197	F
5/16-24	.3179	I
3/8-16	.3831	5/16
3/8-24	.3804	Q
7/16-14	.4468	U
7/16-20	.4440	25/64
1/2-13	.5100	27/64
1/2-20	.5065	29/64
9/16-12	.5733	31/64
9/16-18	.5697	33/64
5/8-11	.6368	17/32
5/8-18	.6322	17/32
3/4-10	.7630	37/64
3/4-16	.7581	21/32
7/8-9	.8894	11/16
7/8-14	.8843	49/64
1-8	1.0162	13/16
1-14	1.0093	7/8
METRIC		
M1.6x0.35	.0651	1.25mm or #55
M2x0.4	.0810 (#46)	1.60mm or #52
M2.5x0.45	.1008	2.05mm or #46
M3x0.5	.1207	2.50mm or #39
M3.5x0.6	.1407	2.90mm or #32
M4x0.7	.1613	3.30mm or #30
M5x0.8	.2010 (#7)	4.20mm or #19
M6x1	.2410	5.00mm or #8
M8x1.25	.3214	6.80mm or H
M8x1	.3197	7.00mm or J
M10x1.5	.4009	8.50mm or R
M10x1.25	.4002	8.80mm or 11/32
M12x1.75	.4805	10.20mm or 13/32
M12x1.25	.4789	10.80mm or 27/64
M14x2	.5600	12.00mm or 15/32
M14x1.5	.5584	12.50mm or 1/2
M16x2	.6387	14.00mm or 35/64
M16x1.5	.6372	14.50mm or 37/64
M18x2.5	.7191	15.50mm or 39/64
M18x1.5	.7159	16.50mm or 21/32
M20x2.5	.7978	17.50mm or 11/16
M20x1.5	.7946	18.50mm or 47/64
M22x2.5	.8765	19.50mm or 49/64
M22x1.5	.8734	20.50mm or 13/16
M24x3	.9583	21.00mm or 53/64
M24x2	.9537	22.00mm or 7/8

* Coarse series shown in bold. Pitch callout not required on metric coarse series.
** Closest size for 75% theoretical thread.

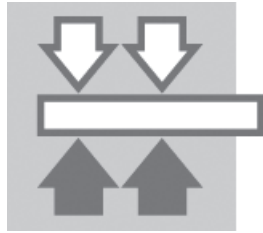

ROEMHELD

HILMA ■ STARK

Carr Lane Roemheld Mfg. Co.

Power Workholding For CNC Machining

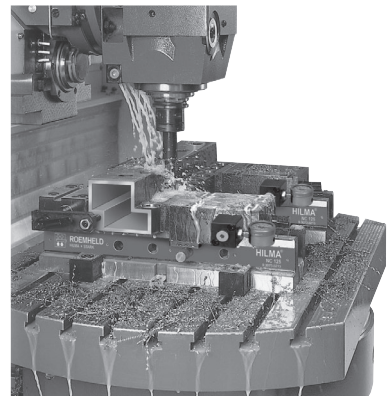
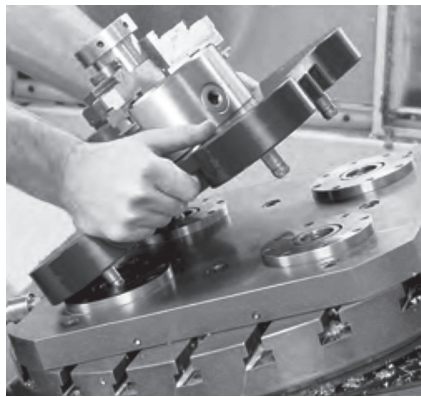
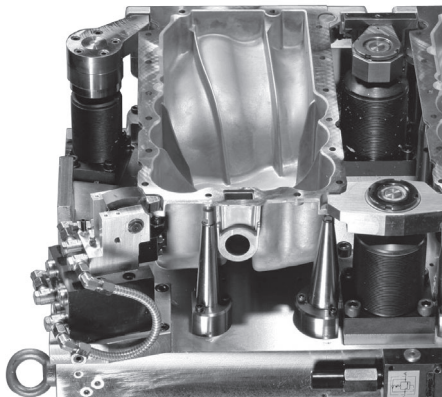

Power Workholding
Precision Vises
Zero Point Mounting
Assembly and Handling

CARR LANE ROEMHELD MFG. CO.

In 1982 an independent joint venture was established to marry the proven product expertise of Roemheld with the tooling industry know-how and distribution network of Carr Lane Manufacturing. This partnership now offers to the American manufacturer the finest in international power workholding, combined with the best in local service and support.



Carr Lane Roemheld supplies North America with engineered hydraulic clamping and quick tool change systems, backed by responsive service and technical support. Used in the automotive, aerospace, appliance and other markets, these high-quality machine tool

accessories and workholders greatly increase manufacturing productivity.



Founded in 1952 in St. Louis, Missouri by Earl E. Walker and family to make standardized tooling components, Carr Lane Manufacturing has grown, through constant innovation, to become the foremost manufacturer and supplier to the American machine tool

industry. Now the most complete line available, Carr Lane Manufacturing offers jig and fixture components, toggle clamps, hoist rings, alignment pins, drill bushings, spring plungers, and modular fixturing. Setting the standard for American tool engineers, Carr Lane Manufacturing's catalog is recognized as the manufacturing engineer's tooling reference.



Drawing upon a centuries-old tradition of German craftsmanship, metalworking was already well established in Laubach, Germany when the Roemheld family began to manage operations in 1870. Development of the hydraulic workholding components

began in the early 1960's and soon grew to dominate the European market. Today, Roemheld GmbH is by far the world leader in this productivity-enhancing technology, offering a tremendous range of power workholding components of superior design and the highest quality.

We invite you to review this section of the catalog in depth and to visit roemheld-usa.com for more information. We at Carr Lane Roemheld welcome the opportunity to assist you in your manufacturing process in the most productive way possible — with the world's most dependable power workholding equipment.

About Us

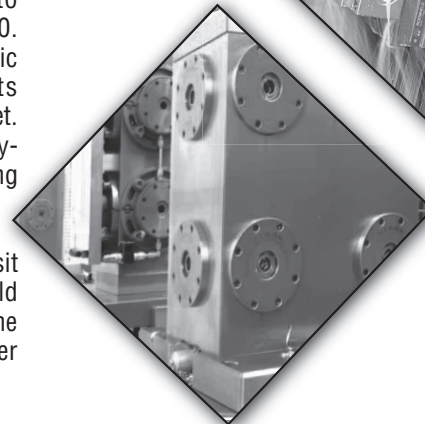
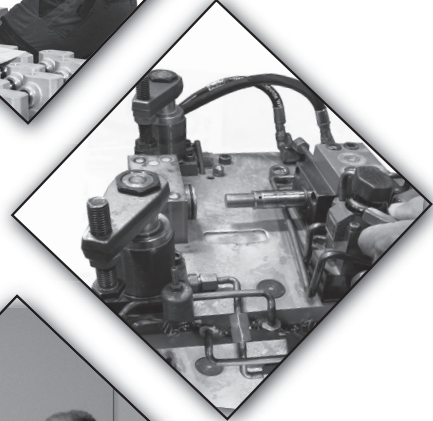

Carr Lane Roemheld Mfg. Co.

Sales — Phone (314) 647-6200 Fax (314) 647-5736

Engineering — Phone 1-800-827-2526 Web roemheld-usa.com

CARR LANE ROEMHELD GUARANTEE OF QUALITY

Carr Lane Roemheld components are carefully designed, manufactured, inspected, and individually tested prior to shipment. In the unlikely case you find a defect in materials or workmanship within 12 months after receipt, we will promptly repair or replace the component, in accordance with our Limited Warranty below. Our liability is limited to replacement of the part and this warranty does not apply to altered or misapplied products.

Limited Warranty

Seller warrants that the product described herein will be free from defects in material and workmanship. If any failure to conform to this warranty be found within twelve (12) months, from date of receipt of the product by Buyer, and Seller is given immediate notification thereof, Seller, upon being satisfied of the existence of such nonconformity, will correct the same by replacement of the defective product or making suitable repairs. If the Seller is unable to correct such nonconformity by replacement of the product or making suitable repairs, whether due to the nature of such nonconformity, the use made by the Buyer of the product, or for any other reason, it will return to Buyer the price set forth herein, or where appropriate, the unit price for such number or quantity of products as shall have such nonconformity which Seller is unable to correct, upon Seller's receipt of the nonconforming product f.o.b. its plant; provided, however, no product shall be returned to Seller without its express written consent; and provided further that such receipt of any nonconforming product will not be required where it is no longer possible for Buyer to return the same to Seller. In no event shall Seller be liable to Buyer, either directly or by way of contribution or indemnity, for direct, special, incidental or consequential damages such as, but not limited to, property damage, loss of profit, damages based on loss of use of the product, or damages for cover, whether the claim for any such damages be based on warranty, express or implied, contract, tort, or otherwise. THE FOREGOING IS SELLER'S SOLE WARRANTY WITH RESPECT TO THE PRODUCT. SELLER MAKES NO OTHER WARRANTIES, EXPRESS OR IMPLIED, INCLUDING IMPLIED WARRANTIES OF MERCHANTABILITY AND FITNESS FOR A PARTICULAR PURPOSE.



ROEMHELD
HILMA ■ STARK

Carr Lane Roemheld Mfg. Co.
Sales — Phone (314) 647-6200 Fax (314) 647-5736
Engineering — Phone 1-800-827-2526 Web roemheld-usa.com

Contents

	Technical Information	Product Features 593-594 Design Information 599-600 Safety Precautions 601
	Clamps & Cylinders	Low-Pressure Clamps and Supports 602 Extending Clamps 603-606 Swing Clamps 613-623 Push Clamps 624-628 Block Clamps 629-630 Universal Cylinders 631-632 Pull Clamps 633-635
	Work Supports	Spring-Extended Work Supports 637-640 Fluid-Advanced Work Supports 637-640 Air-Advanced Work Supports 637-640 Double-Acting Fluid-Advanced Work Supports 641
	Vises, Concentric Clamps & Zero Point Mounting	Machining-Center Vises 644-645 Vise Jaws and Accessories 646-647 CL5 5-Axis Machining Vises 649-655 MC-P Mini Clamp Vises 655 5-Axis Riser, Vise Jaws 656-657 Concentric Vises 652 DropZero Zero-Point Mounting 658-661 Fixture Clamps 662-664
	Power Sources	Electric Power Units 667-670 Air Power Units 671-673 Hand Pumps 674 Screw Pumps 675 Hydraulic Intensifiers 676-677
	Valves	Clamping Valves 680-682 Sequence Valves 684-685 Pressure-Reducing and Closing Valves 683 Check Valves 687 Shutoff and Pressure-Relief Valves 688 Flow-Control Valves 689
	Fittings & Accessories	Rotary Couplings and Pallet Decouplers 691-699 Accumulators 700 Quick Connects and Couplers 701-702 Pressure Switches 703 Air Accessories, Manifolds and Gauges 704 Quick Disconnects 705 Filters, Tubing, Hoses and Fluid 706-708 Fittings, Tubing Tools 709-719 Contact Bolts 717 Lifting Devices 720

Featured Power Workholding Items

BRAND NEW! DropZero™



New Drop Zero!
pages 658-661

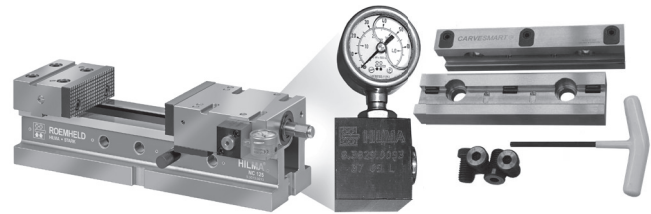

NC Machine Vises with Gauge Carvesmart Bundle
pages 644-645

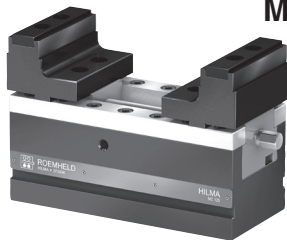

MC-P Z Concentric Machine Vise
page 649



Hinge Clamp Flat Clamping Lever
pages 613-623

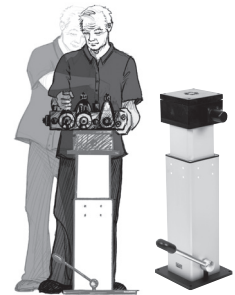

Lifting Units
page 720



Double Acting Threaded-Body Work Support
page 641



Robust Swing Clamps
pages 613-623



Work Supports
pages 637-640



Hinge/Link Clamps
pages 613-623



Compact Clamps
pages 613-623



5-Axis Machining
pages 649-655

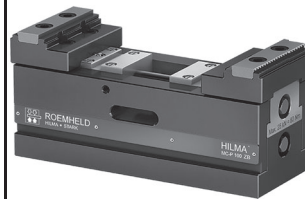
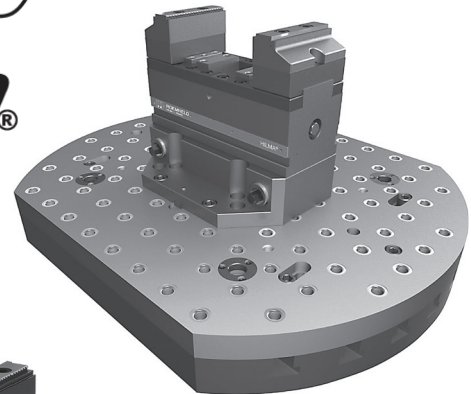

5-Axis Machining Vises
pages 649-655



Quintus Quick-Change Riser
page 654

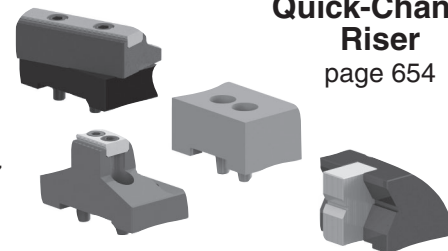

5-Axis Vise Jaws
pages 656-657



ROEMHELD
HILMA ■ STARK

Carr Lane Roemheld Mfg. Co.
Sales — Phone (314) 647-6200 Fax (314) 647-5736
Engineering — Phone 1-800-827-2526 Web roemheld-usa.com

PRECISION MACHINE VISES INCREASE PRODUCTIVITY

Use in Conjunction with the Zero Point Mounting System for Faster, More Accurate Fixture Set Ups

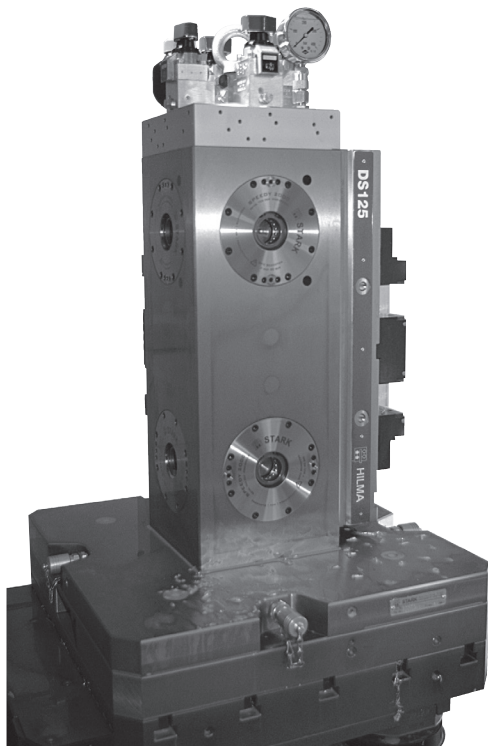
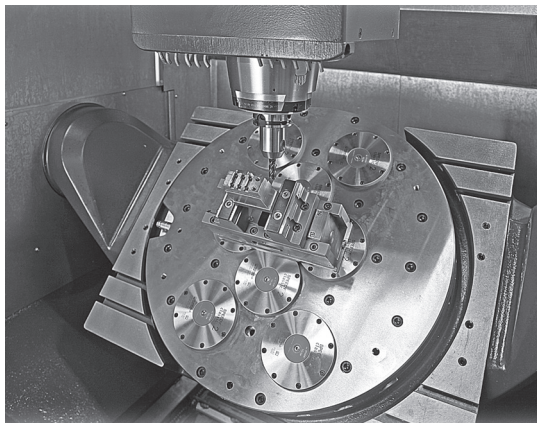
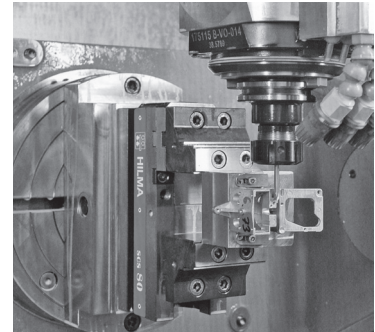

REDUCE SET-UP AND DOWNTIME!

Zero Point Mounting System for Quick Change Fixturing

This comprehensive system utilizes clamping components and insertion nipples, which provide an immediate zero point orientation.

- Reduce set up time by as much as 90% with zero point mounting
- Existing fixtures can be easily adapted
- Highly accurate positioning and repeatability
- Increased productivity
- Fast payback
- Set-up times slashed
- Fixture life extended

View Stark Zero Point Mounting Products at:

www.roemheld-usa.com

Fenton, MO 63026
(636) 386-8022



What makes Roemheld Power Workholding better than earlier hydraulic clamps?

1 Designs specifically and purely for workholding

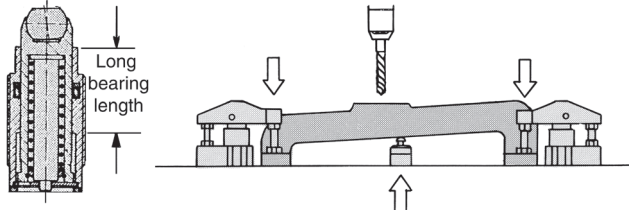

Earlier power clamping products descended from industrial jacks, pipe benders, and rams. Although these early devices (many still on the market) are fine for their original uses, they do not meet the special demands of modern workholding. For example, in a machining application, components are often subject to side loading due to cutting forces, not simply axial loads. This condition requires totally different engineering to provide sufficient bearing lengths for durability. As another example, workholding components are frequently exposed to coolant, chips, dirt, and grit, so clamps must include effective wipers and vent filters. Also, industrial cylinders converted to clamps are usually too bulky to fit easily on fixtures.

2 Compactness, with 7250-psi operating pressure

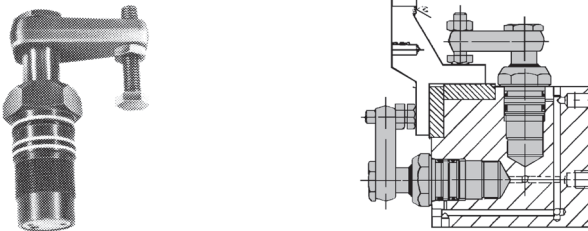

Earlier power clamps could operate at only 2000 to 3500 psi (pounds per square inch) fluid pressure. You needed large, bulky clamps with large internal cylinders to provide enough clamping force. Roemheld components are designed differently, inside and out, to fit easily on fixtures. They work comfortably even at 7250 psi, letting you use much smaller clamps to get the same clamping force. Compact Roemheld clamps open up new fixturing possibilities: you can now place clamps in tighter spots than before, and with the extra space, you can put more workpieces on a fixture (for example, six parts per cycle instead of only 4).

3 Zero-leakage sealing technology

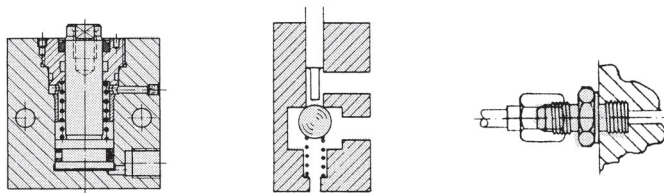

Another feature unique to Roemheld power workholding is leak-free hydraulic sealing. Zero leakage is always important for safe clamping, and is absolutely vital on portable palletized fixtures. Maintaining pressure in a closed, disconnected system requires that *all* components – clamps, valves, and fittings – be leak-free. This calls for drastic changes in sealing techniques: cylinder seals are different, poppet valves (not leaky spool valves) are used whenever possible, and all fittings use metal-to-metal sealing (straight BSPP pipe threads with knife-edge sealing, instead of leak-prone tapered pipe threads).

4 State-of-the-art product development

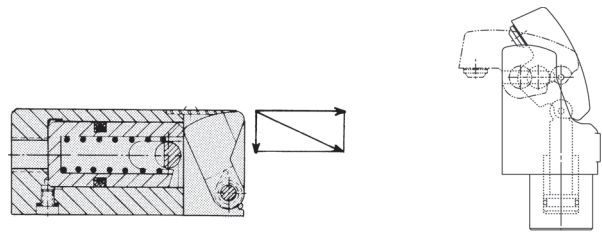

The Edge Clamps and Extending Clamps shown above are just two examples of advanced clamp designs in the Roemheld line. Both set new standards for good engineering and compact size. Our many new products and product improvements result from constant, extensive research and development. New products are field tested and proven, often for years, before they are ever offered for sale.

5 Extensive clamp sizes that follow a logical progression



Roemheld offers a vast selection of clamp sizes and varieties, to match your requirements exactly. In fact, we offer *several times* as many catalog models as our closest competitor (with much better stock too)! Just as important, our clamp sizes follow a logical progression of clamping forces, so you can usually find a clamp that is just the right size.

6 Manifold mounting

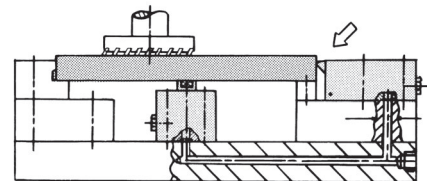

Our Roemheld line pioneered the ever-increasing use of manifold mounting: supplying fluid to clamps through passages drilled in the fixture, rather than through tubing or hoses. Manifold mounting, which requires specially designed clamps, allows designing totally "clean" fixtures without chip traps. Also, manifold mounting lets you put clamps closer together and in tighter spots, often letting you put more workpieces on a fixture.



Carr Lane Roemheld Mfg. Co.

Sales — Phone (314) 647-6200 Fax (314) 647-5736

Engineering — Phone 1-800-827-2526 Web roemheld-usa.com

7 Work Supports

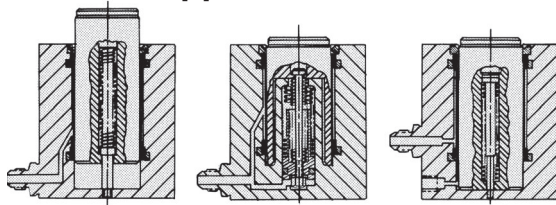

One of the most important improvements in power workholding is the work support. These components do not exert clamping force; instead, they lock off to restrain a workpiece during machining to prevent deflection and vibration. Roemheld work supports offer two major improvements: (1) drastically improved accuracy, with +/- .0002 inches repeatability, and (2) fluid-advanced and air-advanced supports. Fluid- and air-advanced versions offer significant advantages over conventional spring-loaded work supports. A spring-loaded support relies on a workpiece's weight to depress its support plunger to the proper height. While fluid pressure is off, the plunger remains in a raised position on the machine and can hamper loading and unloading. A fluid-advanced work support's plunger, on the other hand, is retracted when fluid pressure is off. Applying pressure first raises the plunger gently to the workpiece, then automatically locks it at the correct height. When pressure is released, the plunger retracts again for clear loading.

8 Swing Clamps

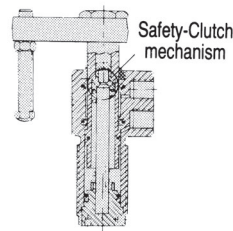
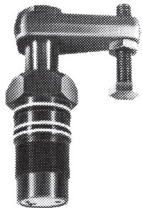

In all modesty, Roemheld Swing Clamps are by far the finest available anywhere, both in features and durability. Our proprietary safety-clutch mechanism prevents damage if the clamping arm strikes an unexpected object, such as an incorrectly loaded workpiece. The arm clutch disengages to avoid damaging the object or the clamp's helical-cam mechanism. In addition, our swing clamps incorporate a fast, totally dependable spring return, unlike our competitors'. We offer many varieties and sizes of swing clamps, including super-miniature and manifold-mounted versions.

9 Power Units for Workholding

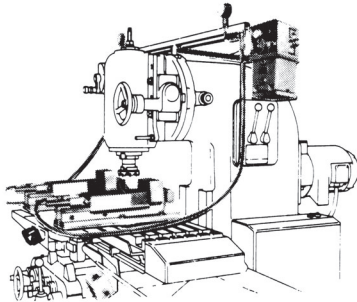

Early power-clamping systems relied either on limited-capacity air/oil intensifiers or on massive, noisy pumps for hydraulic power. Roemheld Electric and Air Power Units are totally different: they are compact, quiet power units designed especially for workholding. These turnkey units include an extremely durable pump, large fluid reservoir, clamping valves, switches, gauges, and numerous safety devices. Workholding power units are becoming a standard accessory on milling machines and machining centers.

10 Pallet Coupling Systems

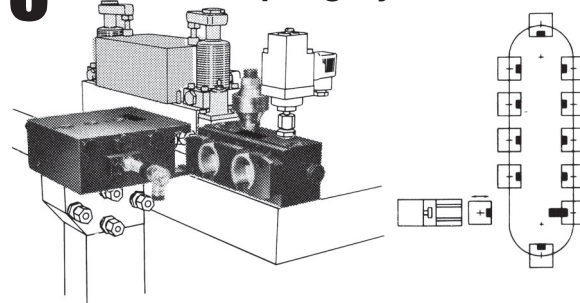

Power clamping on portable palletized fixtures is becoming quite common, yet presents some special challenges, such as maintaining full clamping pressure while the fixture is separated from its power source. We offer a wide choice of solutions, from rotary couplings, to manual pallet decouplers, to automatic coupling systems with programmable controllers.

11 Specials

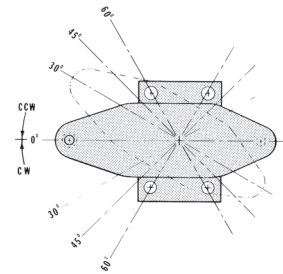
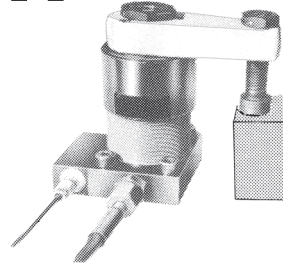

Because many tough clamping problems require modified or totally special components, we offer full specials-engineering capabilities. Our research and development staff can quickly design products to meet your special requirements. And unlike our competitors, we are a full-capability manufacturer, from start to finish, so lead times are always reasonable.

12 Engineering and Service Support

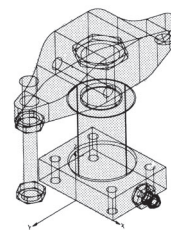

Drawing Files Available at
www.carrlane.com

The combined resources of Carr Lane Roemheld Mfg. Co., Carr Lane Mfg. Co, and Roemheld GmbH bring you the world's finest technical support. Our capabilities include:

- (1) Field engineers and regional managers helping our fine authorized distributors give you on-site assistance nationwide.
- (2) Extensive CAD/CAM capabilities, both inhouse and for customer use, including a complete CAD library of catalog items available for users.
- (3) A large stock of catalog items, plus quick-response manufacturing capabilities.
- (4) Quality products that rarely need service, unlike those of our competitors, who regularly sell replacement parts and need repair stations throughout the country.

Design Information

1. Operating Pressure

Although most Roemheld components operate comfortably and safely at up to 7250 psi, we recommend selecting a standard "design pressure" of 6000-psi for workholding fixtures. The table on each clamp's catalog page shows 6000-psi forces in bold for quick reference.

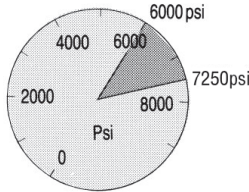

Designing at 6000 psi gives you most of the compactness benefits of high pressures, yet leaves a 25% reserve in case you find that you need additional holding force after building the fixture. Adjust up or down if necessary after checking the fixture. We recommend permanently labeling or stamping the fixture with the chosen operating pressure, for future reference. Operating at low pressures is somewhat a waste of our components' capabilities, but may occasionally be desirable with delicate workpieces. Whenever possible, stay with high pressures and use smaller clamps for better economy and minimum size. Minimum operating pressure is generally 1500 psi using an Electric Power Unit, or 2200 psi using an Air Power Unit. Work supports require at least 1500 psi. Please note, a few products in this catalog are limited to pressures lower than 7250 psi. To use these components in full-pressure systems, see Pressure Reducing Valves.

2. Machining Operations and Fixture Layout

While developing your fixture concept, consider the following factors wherever possible:

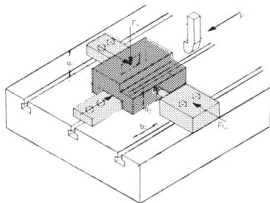

Use positive stops to resist machining forces, rather than relying just on clamp forces. With well-placed locators, you can use smaller clamps.

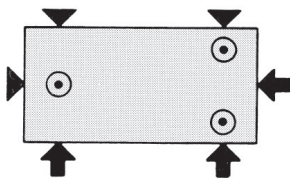

Choose clamping points that are backed up by solid stops or rests to resist clamping forces. Clamping forces can distort a workpiece unless counteracted by firm supports.

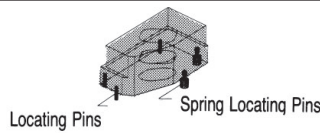

Evaluate workpiece-loading procedure and clamping sequence. Loading and clamping can be completely automatic, or involve some manual steps. To position the workpiece against locators, spring-loaded positioners (above) are often helpful. Sequence Valves are extremely useful to position hydraulically with push clamps before clamping. Total positioning force should be 30-50% of the workpiece's weight to overcome friction.

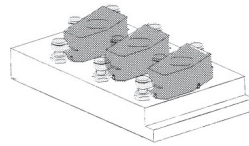

Decide how many parts you want to place on the fixture. For example, to place three workpieces on the above fixture, super-miniature Swing Clamps are necessary. With only one workpiece, just about any clamp would do.

3. Plumbing Options

Supplying fluid to hydraulic fixtures is not merely an afterthought. Fluid supply is an integral part of fixture design. The following Swing Clamp fixtures illustrate four distinct plumbing concepts.

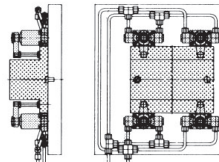

1. Tubing lines on top of fixture plate. This is the oldest, most traditional method of supplying fluid to hydraulic clamps. Before manifold mounting, using tubing was about the only option available. Advantages; less baseplate machining is required; quick build time. Disadvantages: chips are easily trapped in tubing lines; a large base-plate area is required; exposed tubing is subject to damage.

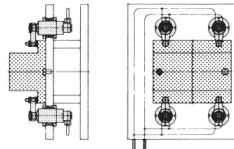

2. Tubing lines underneath fixture plate. Running tubing lines below the working area is an improvement on option 1. Advantages: no chip traps in working area; more freedom to position clamps with tubing out of the way. Disadvantages: a large base-plate area is still required; more complicated fixture construction.

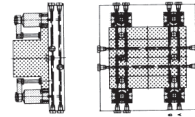

3. Manifold mounting, with O-ring ports. This option uses passages drilled in the fixture to feed fluid directly to O-ring ports underneath the clamps. Advantages: more compact fixture size; no chip traps in working area; most economical construction. Disadvantages; gundrilling is sometimes required; less freedom to mount clamps in odd positions.

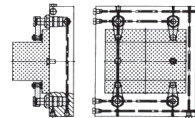

4. Cartridge-type manifold mounting. Similar to option 3, except clamps are embedded in specially prepared, tapped mounting holes. Advantages: most compact fixture size; great freedom to position clamps in tight places; no chip traps in working area. Disadvantages: gundrilling is sometimes required; a thicker base plate is usually required (this is also an advantage because it makes the fixture more rigid).

4. Cutting Forces

An important step in most fixture designs is looking at the planned machining operations to estimate cutting forces on the workpiece, both magnitude and direction. Your "estimate" can be a rough guess based on experience, or a calculation based on machining data. One simple formula for force magnitude is based on the physical relationship:

$$Force = \frac{Power}{Velocity}$$

$$F = \frac{P}{V}$$

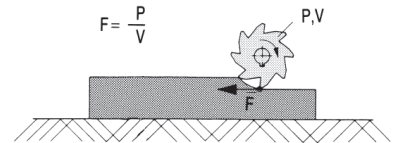

Cutting force (lbs)	Heaviest-cut horsepower × Machine efficiency × 33,000	
	Cutting speed (sfpm)	

Please note: heaviest-cut horsepower is not total machine horsepower, rather it is the maximum horsepower actually used during the machining cycle. Typical machine efficiency is roughly 75%. (.75). The number 33,000 is a units-conversion factor.

The above formula only calculates force magnitude, not direction. Cutting force can have X, Y, and/or Z components. Force direction (and magnitude) can vary drastically from the beginning, to the middle, to end of the cut.



Carr Lane Roemheld Mfg. Co.
Sales — Phone (314) 647-6200 Fax (314) 647-5736
Engineering — Phone 1-800-827-2526 Web roemheld-usa.com

Design Information

Example

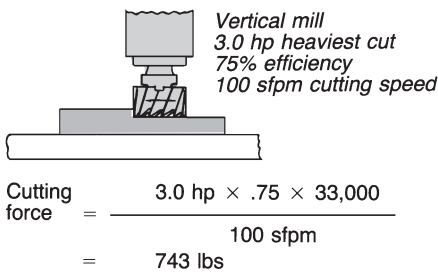

Intuitively, force direction is virtually all horizontal. In this example (negligible z-axis component). Direction varies between the x and y axes as the cut progresses.

5. Clamp Forces / Sizes

Clamping-force calculations can be quite complicated. Sometimes an approximate method is good enough. See table below for how much clamping force is available from manual clamp straps of various sizes (with a 2-to-1 clamping-force ratio) to compare with power-clamp forces.

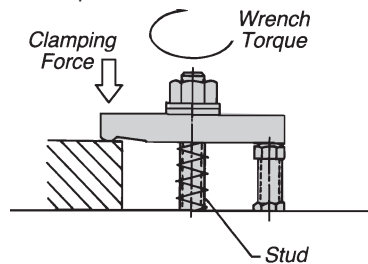

Stud Size	Recommended Torque* (ft-lbs)	Clamping Force (lbs)
1/4-20	4	500
5/16-18	9	900
3/8-16	16	1300
1/2-13	38	2300
5/8-11	77	3700
3/4-10	138	5500

* Clean, dry clamping stud torqued to approximately 33% of its 100,000 psi yield strength (2:1 lever ratio).

You can also calculate required clamping forces based on calculated cutting force. A simplified example appears below, with cutting force entirely horizontal, and no workpiece stops

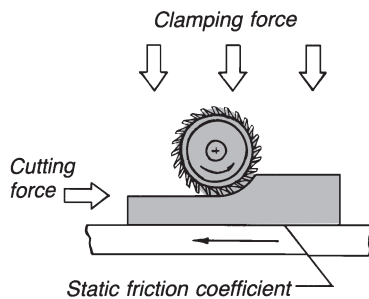

$$\text{Clamping force (lbs)} = \frac{\text{Cutting force (lbs)}}{\text{Static friction coefficient}} \times \text{Safety factor (usually 2)}$$

Contact surfaces	Friction coefficient (Dry)	Friction coefficient (Lubricated)
Steel on steel	.15	.12
Steel on cast iron	.19	.10
Cast iron on cast iron	.30	.19

(frictional force resists the entire cutting force). With workpiece stops and multi-direction forces, calculations become much more complicated. To simplify somewhat, determine the worst-case force situation intuitively, then treat the calculation as a two-dimensional static-mechanics problem (using a free-body diagram). In the example below, cutting force is already known to be 1800 lbs from previous calculations. The workpiece weighs 1500 lbs. Unknown forces are:

- F_R = Total force from all clamps on right side
- F_L = Total force from all clamps on left side
- R_1 = Horizontal reaction force from fixed stop
- R_2 = Vertical reaction force from fixed stop
- R_3 = Vertical reaction force on right side
- N = Normal force = $F_L + F_R + 1500$
- μ = Coefficient of friction = .19

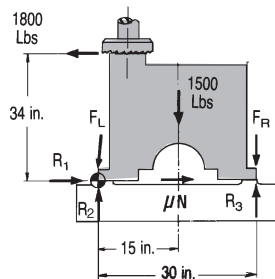
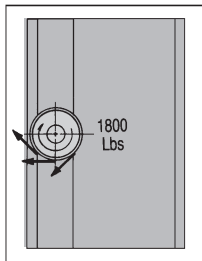

The equations below solve for unknown forces assuming that for a static condition:

- The sum of forces in the x direction must equal zero
- The sum of forces in the y direction must equal zero
- The sum of moments about any point must equal zero

At first glance, the example above looks "statically indeterminate," i.e. there are 5 variables and only 3 equations. But for the minimum required clamping force, R_3 would be zero (workpiece barely touching) and F_L would be zero (there is no tendency to lift on the left side). Now with only 3 variables, we can solve:

$$\begin{aligned} \sum F_x &= 0 \\ \sum F_y &= 0 \\ \sum M &= 0 \end{aligned}$$

$$\begin{aligned} &= -1800 + R_1 + (.19)(1500 + F_R) \\ &= R_2 - 1500 - F_R \\ &= (34)(1800) - (15)(1500) - (30)(F_R) \end{aligned}$$

Solving for the variables,

$$\begin{aligned} F_R &= 1290 \text{ lbs} \\ R_1 &= 1270 \text{ lbs} \\ R_2 &= 2790 \text{ lbs} \end{aligned}$$

In other words, the combined force from all clamps on the right side must be greater than 1290 lbs. We recommend a 2-to-1 safety factor (2580 lbs). Even though F_L (the combined force from all clamps on the left side) equals zero, a small clamping force may be desirable to prevent vibration. Too much clamping force

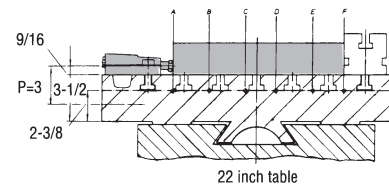

can be as bad as too little. Excess force can cause fixture and machine-table distortion or even damage. Even a small hydraulic clamp can generate tremendous stresses (S). In the

$$S = P \times \left(1 - \frac{1}{1 + \frac{FL^2}{2EI}} \right)$$

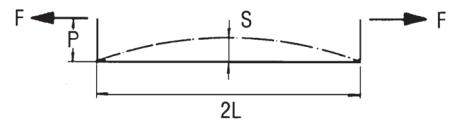

example above, three 4560-lb Edge Clamps cause some machine-table bending. Using static beam-binding calculations, maximum distortion, at point D, is about .0006 inches (probably acceptable). However, if the clamping point were higher off the machine table (P dimension), distortion would be much greater. Higher clamps would require adding an intermediate fixture plate to increase table rigidity.

6. Work Supporting

Unlike clamps, work supports do not actually exert force on a workpiece. After adjusting to the part, work supports essentially become fixed supports or rests. A work support's load capacity increases proportionally as fluid pressure rises:

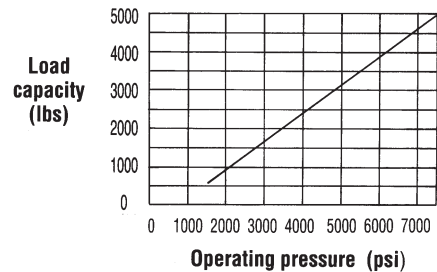

Design Information

Choose enough load capacity to resist: (1) machining forces; (2) workpiece weight; (3) clamping forces not resisted by fixed stops.

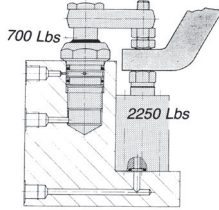

When supporting underneath a clamp, as in the example above, load capacity should be substantially greater than clamping force. Not only must the support resist static clamping force, it must resist dynamic load too (the "hammering" due to clamping-arm momentum). We recommend a load capacity of at least 2 times the clamping force. Another factor when clamping over a work support is that the clamp may build up force faster than the support builds up load capacity. To avoid this, use a sequence valve to delay clamping until load capacity builds up.

7. Single Acting vs. Double Acting

The return side of single acting elements, with a few exceptions (small work supports), require breather ports on the return side, and when used in systems with high flow or pressurized cutting fluids/coolants, great care must be taken to ensure that these fluids do not enter the return side of the clamps. It is highly recommended that double acting elements be used in such systems, thus eliminating the problem, and resultant machine down time. Double acting clamps should also be used in systems having an automatic load/unload, so that all functions can easily be coordinated.

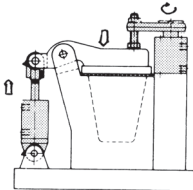

1. Moving linkages or retracting heavy loads. For a quick, positive return when weight is too heavy for spring return.

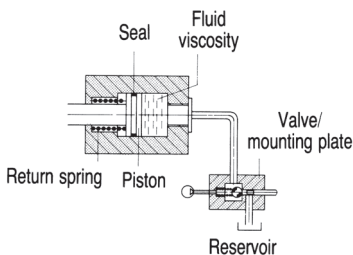

2. Large fixtures with long tubing runs or flow restrictions. Return speed is adversely affected by: (1) pressure drop in tubing and hoses; (2) pressure drop in valves; (3) high fluid viscosity, especially at lower temperatures; (4) frictional force at piston seals, especially when clamped for an extended time, which displaces the fluid film on cylinder walls.

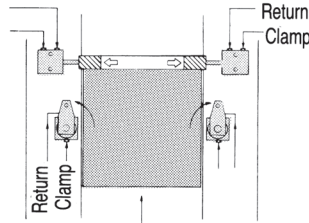

3. Machine-tool interlock. In automated systems where timing and synchronization are important, double-acting clamps are the best choice. By installing pressure switches in both clamping and return lines, a machine controller knows exact clamp status at all times.

8. Clamping Time

Hydraulic clamping is usually fast, but not instantaneous. To estimate clamping time, consider the two phases of clamping:

1. Extending time, under low-pressure free flow
2. Pressure-building time

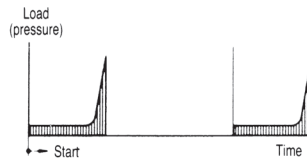

Extending time is fairly easy to calculate, knowing fluid required by each clamp and the power units flow rate, using the formula below. One obvious way to reduce clamping time is to set clamps as close to the workpiece as possible, to use as little stroke as possible.

$$\text{Extend time (sec)} = \frac{\text{Maximum fluid req'd for all clamps (cu.in.)} \times \text{Portion of stroke used (usually 1/2)}}{\text{Power Unit flow rate (cu. in./min.)}}$$

After extending, an additional volume of fluid must be pumped into the system to build pressure. This is due mainly to:

1. Compressibility of the hydraulic fluid (add about 4% of total system volume to build to 7250 psi)
2. Volume expansion of hydraulic hoses (.066 cu.in. per foot)
3. Charging an accumulator, if used

By calculating fluid required for each of the above factors, you can estimate pressure-building time. Using Sequence Valves lengthens clamping time, because each sequence step requires extending time and pressure-building time. To reduce clamping time, set Sequence-Valve trigger pressure as low as possible. With multiple Sequence Valves, set trigger-pressure differences at their minimum allowables value.

9. Other Hydraulic Considerations

The basis of hydraulic clamping systems is "Pascal's Law", which says that if pressure is applied to a static fluid that is completely enclosed, that pressure is transmitted equally in all directions: This principle is used to transmit force to remote locations,

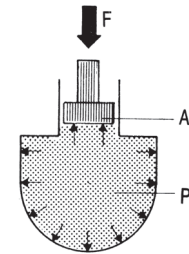

via hose, tubing, or drilled passages. When hydraulic pressure acts on a clamp's piston area, it generates external force according to the physical relationship $F=P \times A$:

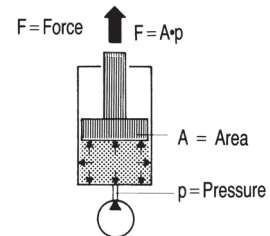

Clamping with hydraulics causes some strange effects not occurring with manual clamps. One such phenomenon is fluid shifting between equal-force opposing clamps.

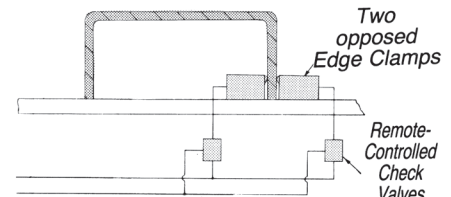

In the example above, the two opposed clamps allow the workpiece to float between them. Pushing on one clamp encounters no resistance because fluid just shifts to the opposing clamp (if the check valves were not present). Do not let equal-force clamps oppose each other without Remote-Controlled Check Valves.

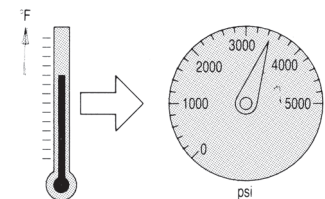

Another strange effect is pressure change due to temperature change of a closed system. In fact, pressure changes about 80 psi per 1° F! Be careful of excessive temperature changes, especially increases. Use a Pressure-Relief Valve for safety.

10. Hydraulic Symbols and Circuit Diagrams

Hydraulic symbols and diagrams are a useful "shorthand" method of describing how a clamping circuit works without detailed drawings. The following pages show two circuit examples, and a summary listing of hydraulic symbols.



Carr Lane Roemheld Mfg. Co.
Sales — Phone (314) 647-6200 Fax (314) 647-5736
Engineering — Phone 1-800-827-2526 Web roemheld-usa.com

Design Information

Bleeding of the Spring Area ■ A0.110

Introduction

Due to increased use of coolants and cutting fluids in machining, there is an increased possibility that these fluids may penetrate into the spring areas of single acting cylinders and work supports. Many fluids can cause corrosion, which can lead to malfunction and possible failure.

Why bleeding is necessary

If not vented, excess pressure or vacuum in the spring area changes the spring forces which may lead to malfunctions.

Condensation from coolants can lead to corrosion on the piston, spring or housing.

Leakage of hydraulic seals must drain properly to avoid malfunctions.

Using sintered metal filters minimizes dust and chips.

Liquids are the real problem because they can be drawn through the air filter. This can cause the spring area to be reduced. Malfunctions can occur due to this excess pressure or vacuum.

Catalog elements with bleeding of the spring area

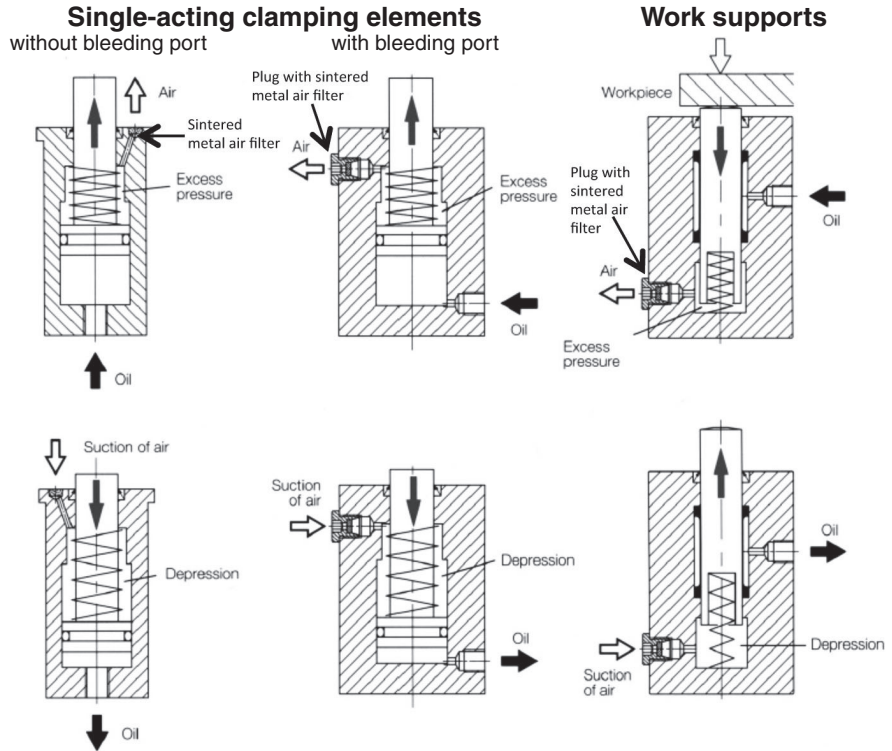

• Venting of Spring Air ■ A0.110

Cover

Clamping elements without bleeding port can be covered, but due to today's normal quantities of coolants this does not seem to be successful. In such applications you should use other clamping elements, preferably double-acting elements.

Bleeding hose

Connection of a bleeding hose is preferred and the opening is to be displaced to a point where no liquid can penetrate.

Closed bleeding system

Connecting the breather port to an external area can increase the spring area volume. By doing this, the amount of additional pressure or vacuum generated is minimal. This serves a dual purpose in allowing the spring area to be vented as well as protection from aggressive coolants. A good solution is to use sealed electrical wiring boxes with connecting threads. **The volume of this additional area should be ten times the stroke volume of all connected elements.**

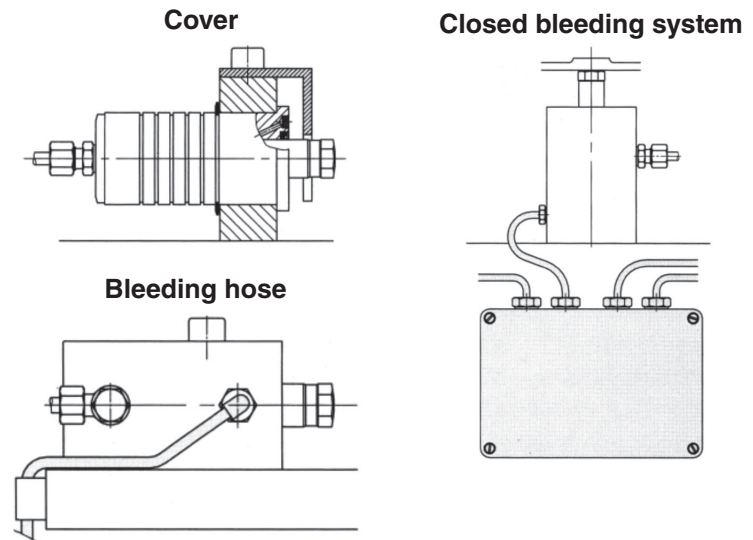

Subject to change. For further details, including detailed dimensions and mounting instructions, visit roemheld-usa.com.

Design Information

Example Hydraulic Circuit Diagrams

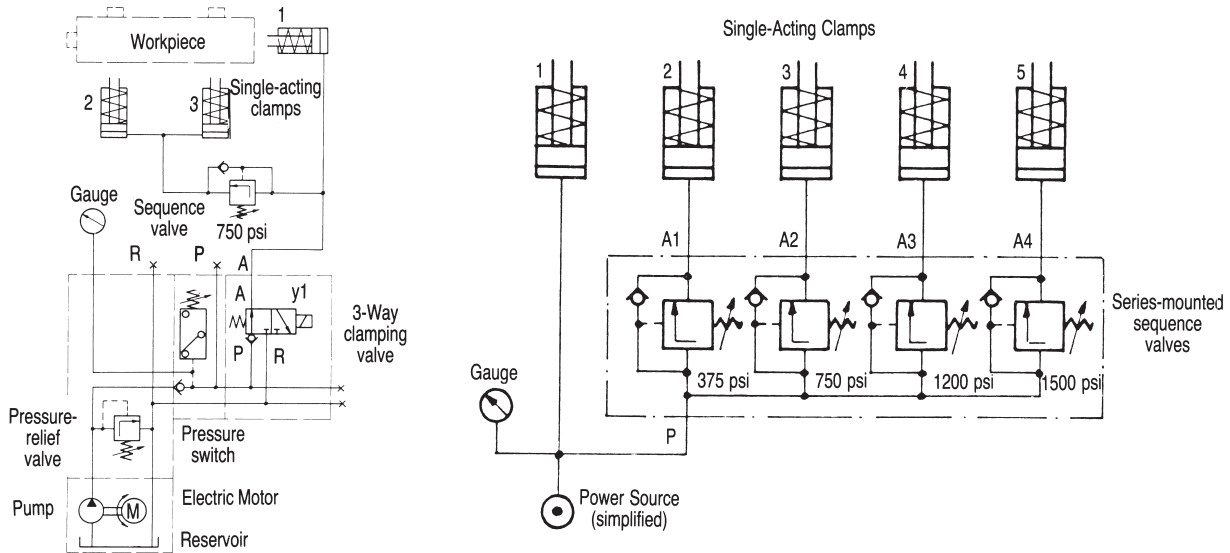





































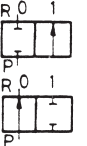

Clamp & Cylinder Symbols		Valve Symbols	
	Push clamp or cylinder, single acting		3/2 directional-control valve (3-way, 2-position), complete symbol with solenoid operator and spring return (normally open)
	Push clamp or cylinder, double acting		Boxes showing valve positions (two). For valves with spring return, the neutral position is shown at left (0).
	Pull clamp, single acting		Inlet and outlet connections are drawn at the neutral-position box, and are designed by capital letters: P = Inlet pressure from pump A, B, C... = Operating connections R, S, T = Outlet return (tank) L = Leakage line Z, Y, Z = Control Lines
	Swing clamp, single acting	Valve Symbols	
	Swing clamp, double acting		
	Extending clamp, single acting	Power Source Symbols	
	Extending clamp, double acting		
	Work support, spring extended		
	Work support, fluid advanced		Power source (simplified)
	Work support, air advanced		



Carr Lane Roemheld Mfg. Co.
 Sales — Phone (314) 647-6200 Fax (314) 647-5736
 Engineering — Phone 1-800-827-2526 Web roemheld-usa.com

Design Information

	Flow lines and directions are shown in each valve-position box. Lines show flow path, arrows show flow direction. Shutoffs are designated by capped-off lines inside the box.		Check valve
			Remote-controlled check valve (pilot operated)
			Shutoff valve
			Pressure-relief valve
			Flow control valve, with unrestricted return line
	Valve operators are shown outside the boxes	Accessory Symbols	
	Solenoid operated		Operating line, pressure or return
	Spring operated (or returned)		Control line, for transmitting control/pilot signals
	Manually operated		Leakage line, for carrying away fluid leakage
	Detent position		Flexible line, such as hydraulic hose
	Lever operated		Line connection
	Foot-pedal operated		Line crossing, without connection
	Push-button operated		Pressure-connection point, such as a port
	Cam-roller operated		Bleeding point
	Plunger operated		Quick disconnect, coupled
	Air-pilot operated		Quick disconnect, decoupled
	2/2 directional-control valve, normally closed on top, normally open below.		Rotary coupling (2 passage shown)
	4/2 directional-control valve, for double-acting clamps		Accumulator
	Sequence valve, with unrestricted return line		Gage
	Pressure-reducing valve, with unrestricted return line		Pressure switch
			Air filter/regulator/lubricator

Recommended Precautions For The Designer, Builder & Operator



IMPORTANT: READ THIS SHEET CAREFULLY BEFORE OPERATING.

Roemheld power workholding components are high quality products, engineered and manufactured to give you long, dependable and safe performance. For proper and safe operation, please follow all instructions on this sheet. Save these instructions for future reference.

SERVICE NOTE: Most Roemheld components are 100% individually tested for proper operation before leaving the factory. Please recheck these instructions if your new unit does not work properly. Should any component ever need service, please contact the factory. Do not disassemble the unit yourself — many are not user serviceable. Roemheld components incorporate advanced sealing technologies that eliminate the need for routine seal replacement.

TUBING: Use only *steel* tubing as specified in the Roemheld catalog: Seamless steel tubing, C1010, cold drawn, fully annealed, 5/16 OD, .065 wall thickness (Certified to 37,500 psi burst). Follow all tubing installation guidelines. We highly recommend the CLR-300-TL flaring tool to effectively flare this heavy-walled tubing.

HOSES: Use only hydraulic hoses as specified in the Roemheld catalog: 1/4 ID hydraulic hose, 25,520 psi min. burst pressure, (2) female swivel-nut ends, 5/16 JIC 37° flare.

FLUID CONNECTIONS: Connect fluid lines to the 5/16 JIC 37° flare male connection on each clamp (two for double-acting clamps). This fitting accepts either 5/16 OD 37° flared tubing, or a hydraulic hose with 5/16 JIC 37° swivel nuts (female) at each end. **Do not screw NPT pipe fittings into Roemheld components, or use NPT fittings anywhere in a workholding system.** Roemheld fittings are 5/16 JIC 37°. These fittings offer a positive metal-to-metal seal. **Do not use teflon tape or sealant.** Do not use fitting sizes other than 5/16. This size is ideal for workholding fixtures. Smaller tube sizes have poor flow rates. Larger tube sizes are not readily available with sufficient wall thickness for high pressure operation, and are difficult to flare. Never use brass fittings.

OPERATING PRESSURE: Do not operate components above their maximum allowable fluid pressure stated in the Roemheld catalog (7250 psi for most components). Always use a gauge to monitor fluid pressure. Locate pressure gauge where the machine operator can easily read it. Often, placing it directly on the machining fixture is best. All Roemheld Electric and Air Power units include a fluid-pressure gauge.

ADDITIONAL SAFETY PRECAUTIONS: If losing fluid pressure (due to a cut hose, etc.) would pose any danger to the operator, install a pressure switch, or other pressure-monitoring device, to monitor system pressure. This switch electrically signals the machine tool to shut down if fluid pressure is inadequate.

COMPONENT COMPATIBILITY: Do not mix non-Roemheld components into a Roemheld power-workholding circuit. Other brands are not leakfree, and their performance may be unpredictable.

HYDRAULIC FLUID: Always use absolutely clean, fresh hydraulic fluid. Fill the fluid under absolutely clean conditions. **Almost all service problems are caused by dirty, contaminated fluid. Fluid must be clean to 10 micron or better nominal filtration.** Use only the following DIN 51524, HLP, ISO Grade fluids to preserve your warranty:

Oil Temp. [°C]	Designation [as per DIN 51524]	Application
10-40	HLP 22	Power units with poppet valves or single acting circuits
15-50	HLP 32	Mechanical pumps or double acting circuits

See also CLR-000-V, high pressure in-line filter.

BLEEDING AIR: Usually components will bleed trapped air automatically when you clamp and unclamp them several times. If manual bleeding is still necessary, bleed at an elevated tube or hose connection, farthest from the power source. With the clamps actuated (system pressurized) slightly loosen the connection. After fluid seeps out for a few seconds, retighten. Repeat at other connections if necessary. After bleeding, unclamp (depressurize system) and refill the power sources fluid reservoir.

CAUTION: ALWAYS KEEP HANDS CLEAR OF POWER CLAMPS DURING OPERATION. THESE COMPONENTS EXERT VERY HIGH FORCES AND CAN CAUSE SERIOUS INJURY. DISCONNECT POWER SOURCE BEFORE CONNECTING, DISCONNECTING, ADJUSTING, OR OTHERWISE HANDLING COMPONENTS.

FLOW CONTROL: When using Swing Clamps, Extending Clamps, or Fluid-Advanced Work Supports with a high-flow-rate power source, make sure the fluid flow rate to each component is under the maximum stated in the catalog. Otherwise the components may not activate properly. See the Roemheld catalog for flow control valves.

FLOOD COOLANT: Work Supports and Swing Clamps have air vents protected by sintered-metal filters. These vents could draw in coolant if the components are submerged. To prevent this, attach an air vent tube via the tapped hole provided (see each component's catalog page for air-vent-fitting part numbers).

PRESS-TOOL CLAMPING: Clamping die sets on presses require different components and safety devices than found in our Roemheld Power Workholding catalog. Contact factory for press-tool clamping systems.

MOUNTING: Carefully follow mounting instructions as shown in the Roemheld catalog for each component.



ROEMHELD
HILMA ■ STARK

Carr Lane Roemheld Mfg. Co.
Sales — Phone (314) 647-6200 Fax (314) 647-5736
Engineering — Phone 1-800-827-2526 Web roemheld-usa.com

Low Pressure Clamps ■ Work Supports

Advantages

- Low pressure high clamping force.
- Can be ran off machine hydraulic, so an additional power unit is unnecessary.
- Improved production rate and quality over manual clamping.
- See website or contact engineering for more information.

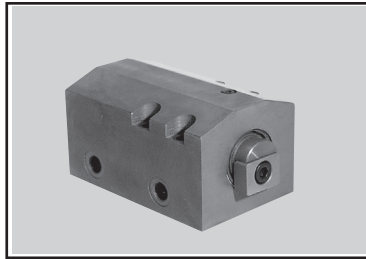

B1.8233 Block Clamps 70 / 100 bar

Hydraulic block clamps are particularly suitable for clamping of workpieces, that require a large free space for machining, and for applications where conventional clamps and swing clamps are too big. Clamping direction adjustable and in small recesses and bores. Clamping force of 540-2920 lbf.

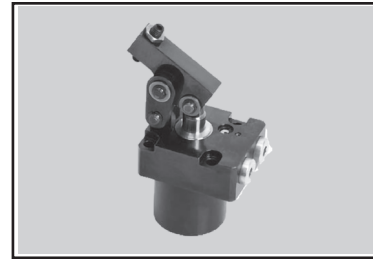

B1.8268 Hinge Clamps with Throttle Valve 70 bar

Hydraulic Hinge Clamps are designed for the direct connection to the lowpressure hydraulics of machine tools. Special kinematics allow clamping without side loads of workpieces which are very sensitive against deformation. Clamping force of 515-3865 lbf.

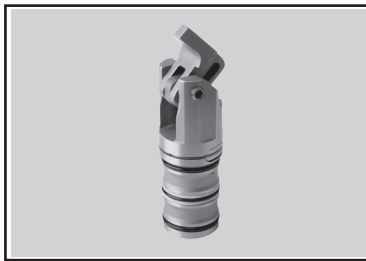

B1.8271 Mini Compact Clamp 200 bar

Mini compact clamps are designed for application in hydraulic clamping fixtures where oil supply is effected through drilled channels in the fixture body. Clamping force of 20-290 lbf.

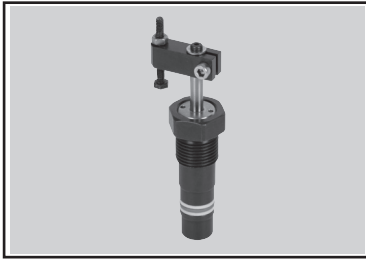

B1.848 Mini Swing Clamps with Sturdy Swing Mechanism 150 bar

This double-acting mini swing clamp works as pull-type cylinder where a part of the total stroke is used to swing the piston. Mini swing clamps are particularly suitable for machining of thin-walled workpieces, which require only little clamping forces. Clamping force of 20-135 lbf.

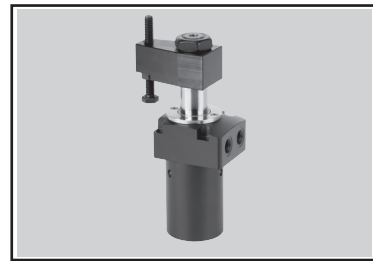

B1.8500 Swing Clamps with Sturdy Swing Mechanism 70 bar

The hydraulic swing clamp with sturdy swing mechanism can be directly connected to the low-pressure hydraulics of the machine tool. Clamping force of 135-2990 lbf.

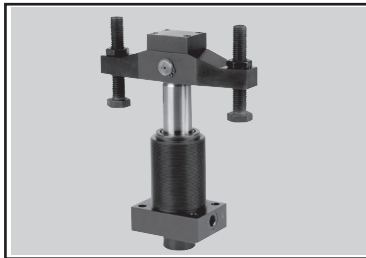

B1.8802 Swing Clamps with Reinforced Swing Mechanism 160 bar

The Swing Clamps with Reinforced Swing Mechanisms are designed with a double clamping arm which gives the ability to clamp 2 work pieces at the same time. Forked head for simple clamping arms. Clamping force of 315-785 lbf.



B1.947 Threaded-Body Work Supports 70 bar

Hydraulic work supports are used to provide a self-adjusting rest for the workpiece during the machining operations. They compensate the workpiece surface irregularities, also vibration and deflection under machining loads. Support force up to 900 lbf.



B1.9472 Threaded-Body Work Supports 70 bar

This series of Threaded-Body Work Supports can be directly connected to the low-pressure hydraulics of the machine tool. The extension, a shaft diameter of 16 mm, enables the support of surfaces in recesses and cavities that otherwise would be inaccessible. Support force up to 675 lbf.

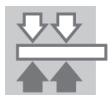

Down-Holding Clamps

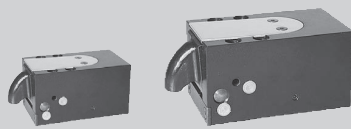

Flat Profile
pages 605-606

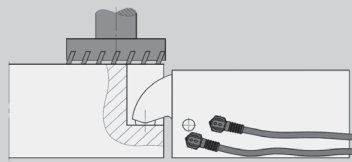

Compact Clamps
page 608

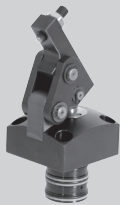
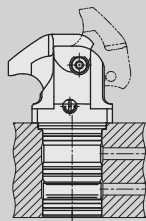

Hinge/Link Clamps
pages 609-611

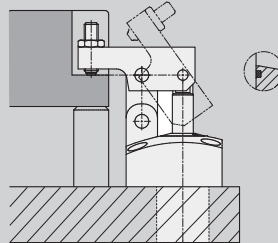

Extending Clamps

Arm extends forward to clamp, then retracts again for clear loading when unclamped. Ideal for clamping in narrow recesses.

Flat Profile Clamps extend in a smooth, continuous radial motion. The arm retracts fully for loading. Choice of swivel-pad arm or spherical-nose arm. **Compact** Clamps have a sturdy lever mechanism that pivots into clamping position. These clamps are extremely compact both in footprint and overall height. The clamping lever pivots a full 90° for clear loading even when using custom long clamping levers. Ideal for clamping in narrow recesses.

Compact Clamps have a metallic wiper edge, and are especially suited for applications where space is limited. Two different clamping levers are available, which can be machined to adapt to your workpiece, then swiveled into small recesses for unimpeded loading and unloading. Four different sizes of the clamp are available, each with a short or long clamping arm.

Hinge or Link Clamps are ideal in narrow recesses, and have a fully retractable arm for clear loading from above. Hinge clamps are ideal for manifold mounting, and are available in more than 100 variations.



Low Profile
page 607

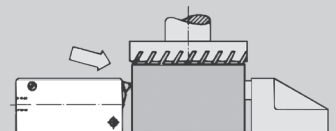

Edge Clamps

Nose advances to grip side of workpiece. Clamping thrust is both forward and down. Ideal when clamping from above would interfere with machining.

Low profile edge clamp sits below cutter path yet still clamps high on workpiece...important for solid, vibration-free clamping.



ROEMHELD
HILMA ■ STARK

Carr Lane Roemheld Mfg. Co.
Sales — Phone (314) 647-6200 Fax (314) 647-5736
Engineering — Phone 1-800-827-2526 Web roemheld-usa.com

Down-Holding Clamps

Air-Powered Swing Clamps

Ideal when only light clamping force is required. Powered by low-pressure shop air.

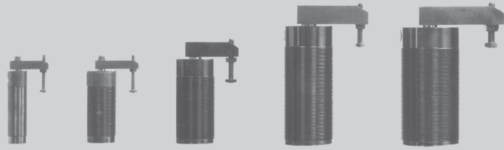

pages 613-614

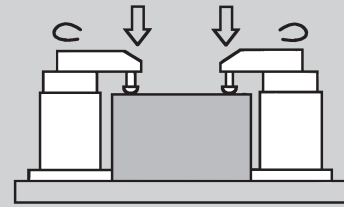

Swing Clamps

Arm swings 90 degrees then clamps down. Ideal when you need maximum reach and clearance for loading/unloading. Proprietary safety-clutch mechanism prevents damage if the clamping arm strikes an unexpected object during its swing.

Flange base swing clamp is good for taller workpieces. Very popular because it takes up little area on the fixture. Mount either on top of fixture or through fixture plate.

All threaded swing clamp is well-suited for through-hole mounting. Fittings are underneath clamp to keep plumbing away from workpiece area.

Top Flange swing clamp has high-level fittings. Mounts in a tapped or bored hole, with plumbing running above the fixture plate or using manifold mounting.

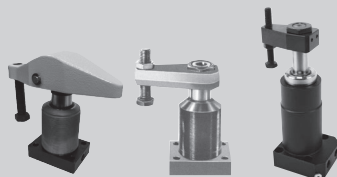

Flange Base
pages 615-616

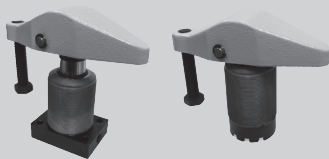

All Threaded
pages 619-620

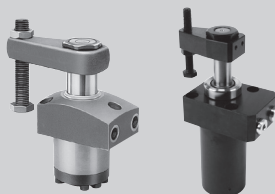

Top Flange
pages 617-618

Swing Clamp Arms pages 618-620



Extending Clamps ■ Flat Clamp ■ B1.8231

Flat Clamp ■ with optional position monitoring ■ Double Acting
Max. Operating Pressure ■ 7250 psi (500 bar)



- Flat, compact design
- High protection against chips and spatter
- Large clamping stroke
- Clamping lever completely retracts
- Optional position monitoring
- Designed to resist side forces at the clamping point

The flat clamp is a double-acting hydraulic clamping element available in two sizes with two lever options. Oil can be supplied via fitting connection or manifold mounted. The clamping lever is connected to the piston by a connecting rod and retracts completely within the body of the clamp allowing for vertical part loading.

IMPORTANT NOTES: When mounted vertically, it is recommended to remove the cover plate to allow for coolant and chip drainage. Other notes can be found in A 0.100.

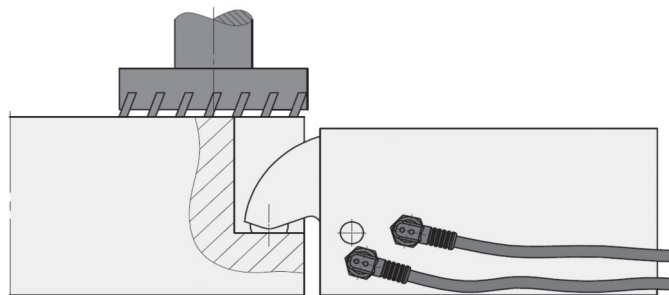

These extending clamps have an extremely low profile for excellent machining clearance.

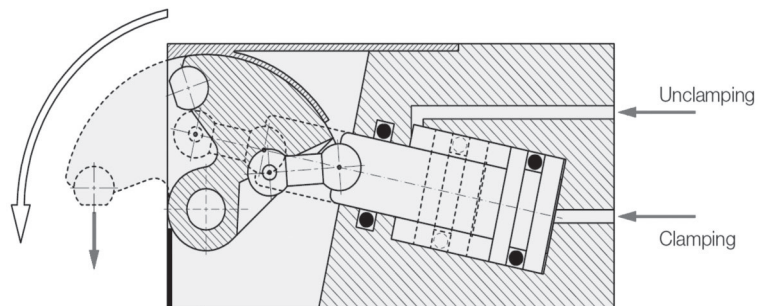

Cutaway view of Swivel Nose Model



ROEMHELD
HILMA ■ STARK

Extending Clamps ■ **Flat Clamp** ■ B1.8231

Flat Clamp ■ with optional position monitoring ■ Double Acting
 Max. Operating Pressure ■ 7250 psi (500 bar)

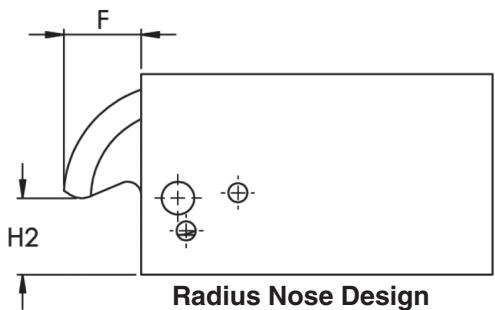
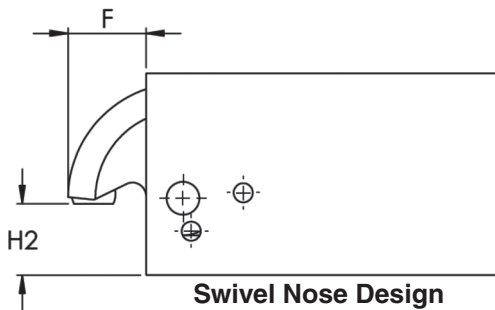
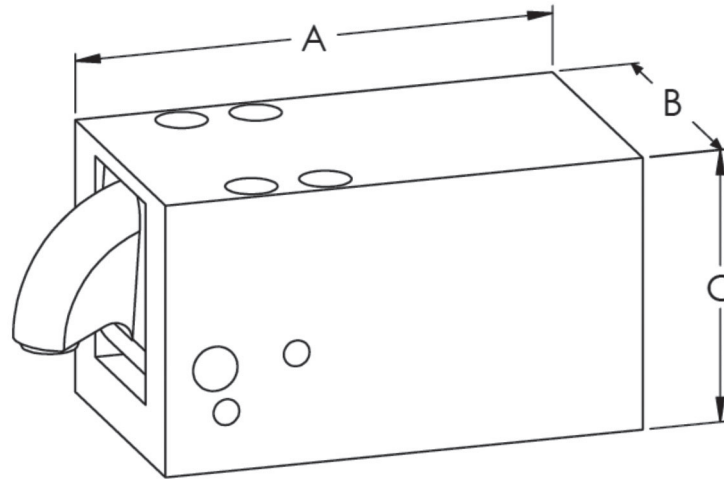

Swivel Pad Contact Bolt

Clamp Force (lbs)	Size	
	Size 1	Size 2
7250 psi	3050	4940
4000 psi	1680	2720
2000 psi	840	1360
A	4.27	5.08
B	2.36	2.95
C	2.30	2.89
F	0.94	1.12
H2 (min.)	0.75	0.96
Weight (lbs)	5.0	9.5
Part No., Clamp	CLR-1824-202	CLR-1824-262

Radius Nose Contact Bolt

Clamp Force (lbs)	Size	
	Size 1	Size 2
7250 psi	2760	4780
4000 psi	1520	2640
2000 psi	760	1320
H2 (min.)	0.71	0.87
Part No., Clamp	CLR-1824-201	CLR-1824-261

Accessories

Part No., Screw Plug G 1/4	CLR-810-F
Part No., Plug Connection NW5	CLR-9210-132
Part No., Inductive Prox Switch	CLR-3829-263
Part No., Rt Angle Plug for Switch	CLR-3829-099

Subject to change. For further details, including detailed dimensions and mounting instructions, visit roemheld-usa.com.



Carr Lane Roemheld Mfg. Co.
 Sales — Phone (314) 647-6200 Fax (314) 647-5736
 Engineering — Phone 1-800-827-2526 Web roemheld-usa.com

Edge Clamps

7250 psi max
Single acting

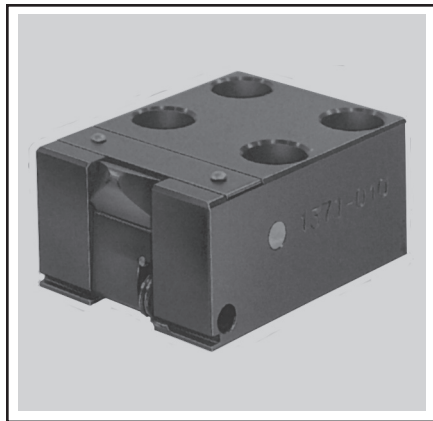

Low Profile

- Grips side of workpiece . . . pushes forward and down
- Ideal when clamping from above is difficult
- Down-holding force is 1/3 of total clamping force
- Sits low yet clamps high . . . just below the cutter path to reduce vibration
- Choice of three sizes

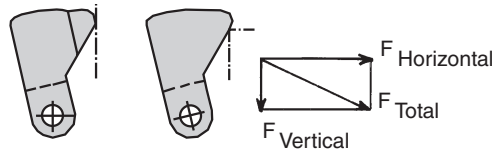

Low-profile edge clamps can be used to grip the side of a workpiece for machining clearance, or to clamp over the top edge.

CLAMPING ACTION: Fluid pressure advances the cylinder, which in turn pivots the nose forward and down to grip side of workpiece. Spring return.

MOUNTING: Fasten with four socket-head cap screws. 1/4 BSPP connection. Same unit may be mounted without external plumbing lines. To manifold mount, order CLR-3000-347-SW O-ring and CLR-810-F port plug.

CONSTRUCTION: Internal cylinder pushes pivoting nose. Nose cover keeps out chips and debris. Body made from carbon steel, black oxide finish. Forged, alloy steel nose, hardened to RC 56-58. Nose is through-hardened so that it can be ground to suit the workpiece if desired.

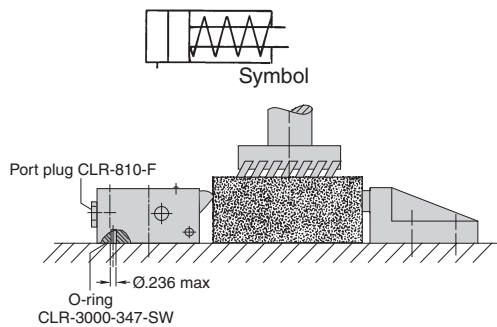

Low-profile edge clamps can be mounted low, yet clamp up high, just below the cutter path to reduce vibration. Edge clamps can be manifold mounted on a flat surface by unplugging the bottom port and installing o-ring CLR-3000-347-SW, then plugging the 1/4 BSPP port plug.

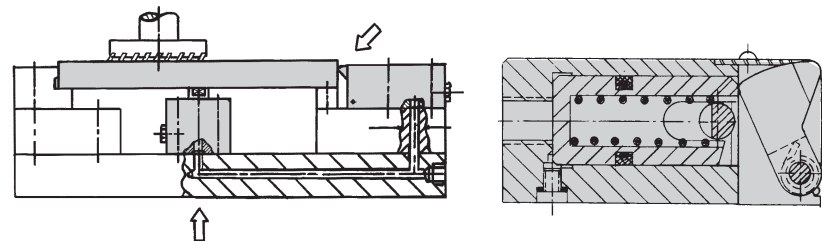

Edge clamp used with a block-type work support, both components manifold mounted for easy chip removal.

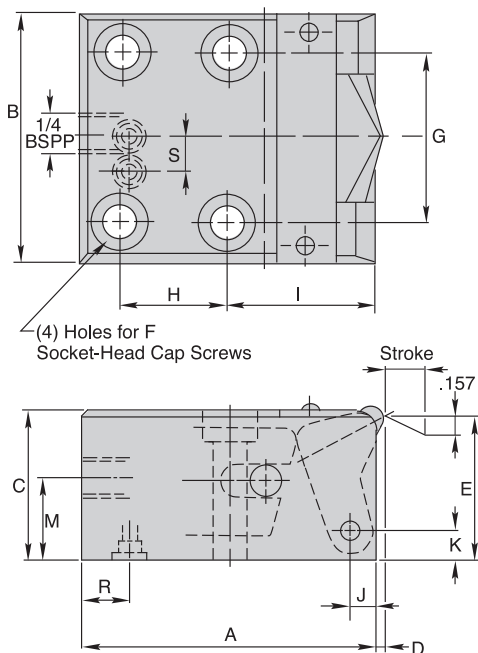

Clamping force (lbs)	7250 psi	1910	4495	8990
	6000 psi	1600	3700	7400
	5000 psi	1300	3100	6200
	4000 psi	1100	2500	5000
	3000 psi	790	1900	3700
Clamping stroke	.31	.39	.39	
Fluid required (in. ³)	.10	.30	.62	
Piston Ø	16mm	25mm	36mm	
Force per 1000 psi (lbs)	260	612	1223	
Max. operating pressure (psi)	7500	7500	7500	
A	2.677	3.543	3.780	
B	1.97	2.36	3.15	
C	1.26	1.57	1.97	
D	.079	0	.079	
E	1.220	1.535	1.929	
F	5/16 or M8	5/16 or M8	3/8 or M10	
G	1.260	1.575	2.205	
H	1.063	1.496	1.496	
I	1.260	1.654	1.811	
J	.217	.236	.315	
K	.236	.354	.433	
M	.75	.91	1.06	
R	.512	.551	.630	
S	0	0	.551	
Weight (lbs)	2.0	2.5	4.6	
Part No.	CLR-110-EC	CLR-310-EC	CLR-410-EC	



Carr Lane Roemheld Mfg. Co.

Sales — Phone (314) 647-6200 Fax (314) 647-5736

Engineering — Phone 1-800-827-2526 Web roemheld-usa.com

Extending Clamps ■ Compact Clamp ■ B1.827

Compact Clamp ■ Cartridge type with pneumatic clamping monitoring
Double Acting ■ Max. Operating Pressure ■ 3625 psi (250 bar)

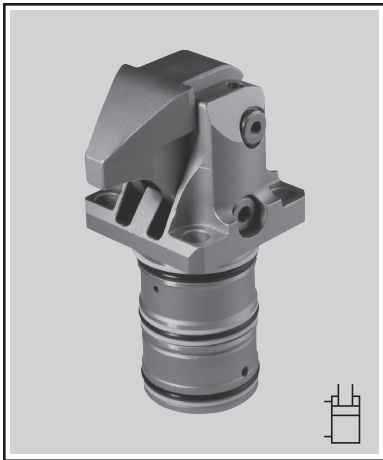

The compact clamp pivots over the workpiece, then clamps in a downward stroke without applying any side load to the part like similar clamps. When retracted, the arm is behind the front plane of the clamp allowing for unobstructed top loading. It has a small footprint with large clamping force. Metal wiper on piston rod and nitrated finish helps protect

this clamp from chips and coolant for a long life cycle. Four Sizes, three mounting options and two arm options help the designer choose the optimal clamp for their application. The long arm can be machined to fit into pockets. The clamp for closed bore mounting does not include the lower protective cap which makes the overall height shorter.

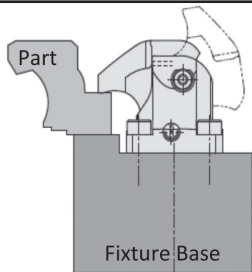

Open Bore Mounting

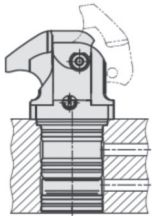

Closed Bore Mounting

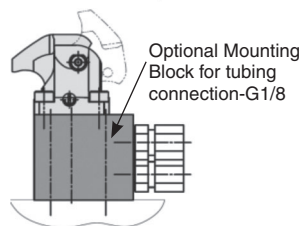
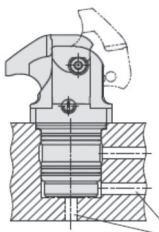

Optional Mounting Block for tubing connection-G1/8

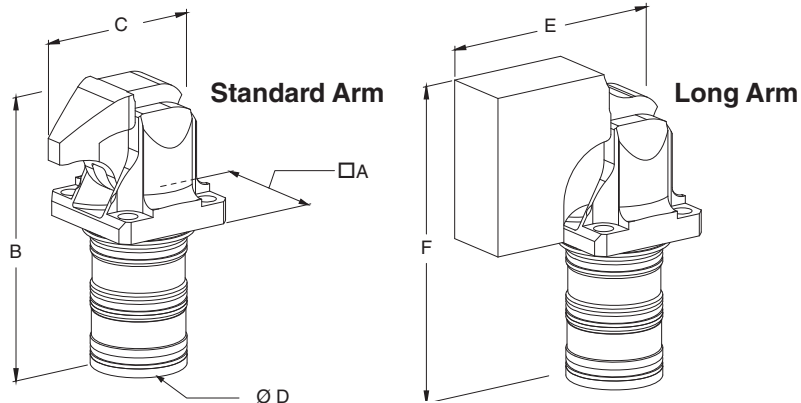

Clamp Force (lbs)	3625 psi	Size 1	Size 2	Size 3	Size 4	
		2000 psi	560	900	1680	2360
		1000 psi	310	495	930	1300
		150	245	465	650	

Open Bore Mounting				
A	1.34	1.65	1.89	2.17
B	3.03	3.33	3.90	4.15
C	1.73	1.93	2.38	2.52
Ø D	0.98	1.26	1.57	1.77
E	2.19	3.19	3.60	3.74
F	3.38	3.60	3.90	4.15
Weight standard version	0.60	1.06	1.87	2.31
Part No., Clamp - Standard Arm	CLR-1801-110	CLR-1802-110	CLR-1803-110	CLR-1804-110
Part No., Clamp - Long Arm	CLR-1801-130	CLR-1802-130	CLR-1803-130	CLR-1804-130

Closed Bore Mounting				
B	2.73	2.97	3.58	3.77
F	3.09	3.24	3.59	3.77
Weight standard version	0.53	0.93	1.68	2.03
Part No., Clamp - Standard Arm	CLR-1801-111	CLR-1802-111	CLR-1803-111	CLR-1804-111
Part No., Clamp - Long Arm	CLR-1801-131	CLR-1802-131	CLR-1803-131	CLR-1804-131

Accessories				
Part No., Spare Standard Arm	CLR-3548-1121	CLR-3548-1122	CLR-3548-1123	CLR-3548-1124
Part No., Spare Long Arm	CLR-3548-1071	CLR-3548-1072	CLR-3548-1073	CLR-3548-1074
Part No., Mounting Block	CLR-3468-381	CLR-3468-382	CLR-3468-383	CLR-3468-384

Subject to change. For further details, including detailed dimensions and mounting instructions, visit roemheld-usa.com.



ROEMHELD
 HILMA ■ STARK

Carr Lane Roemheld Mfg. Co.

Sales — Phone (314) 647-6200 Fax (314) 647-5736
 Engineering — Phone 1-800-827-2526 Web roemheld-usa.com

Extending Clamps ■ Hinge Clamp ■ B1.829

Hinge Clamp with Flat Clamping Lever ■ with pneumatic position monitoring* Single and Double Acting ■ Max. Operating Pressure ■ 3625 psi (250 bar)



The cartridge style compact hinge clamp with flat clamping lever is especially suitable for fixtures with minimal space. It allows for machining of surfaces that are only a few millimeters above the clamping point. When clamping, the piston moves upwards against the rear edge of the lever and pivots it to the clamped position. The piston force is diverted 180° onto the workpiece. The force is dependent on the operating pressure and length of lever.

When unclamping the lever is pivots back to the unclamp position by means of a hook-shaped carrier on the piston. Double acting is required for time and cycle dependent installations, since the return stroke is precisely defined. Typical applications for double acting are multiple clamping fixtures with many workpieces that are closely arranged, rotary indexing fixtures in horizontal and vertical machining centers, assembly lines. These clamps are intended to be used with hydraulic fluid only.

Installation and connecting possibilities

Single acting

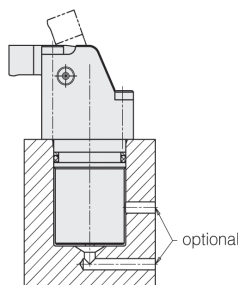

Double acting

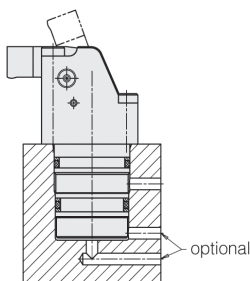

Long clamping lever (blank)

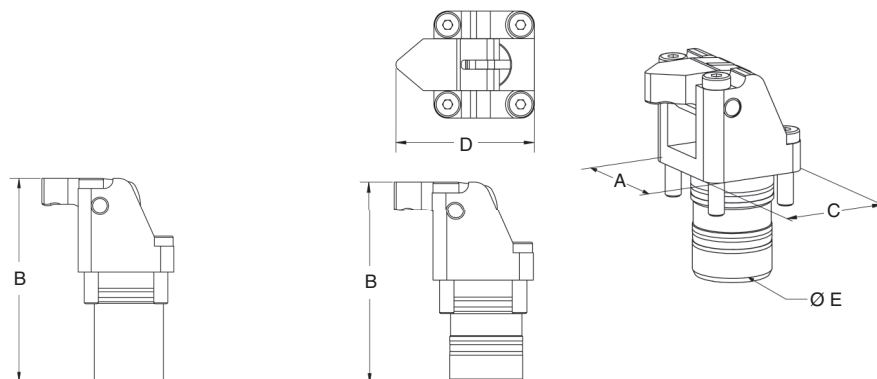
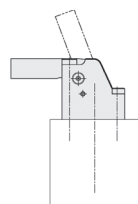

Double acting with standard arm

			Size 1	Size 2	Size 3	Size 4
Clamping Force (lbs)	3625 psi	Single acting	560	740	1300	2200
		Double acting	720	1125	1955	2920
	2000 psi	Single acting	310	410	720	1215
		Double acting	395	620	1080	1610
1000 psi	Single acting	155	205	360	610	
	Double acting	200	310	540	805	

Single Acting - Without Position Monitoring

A (in.)	1.38	1.65	2.09	2.60
B (in.)	2.77	3.45	3.91	5.02
C (in.)	1.30	1.65	2.13	2.48
D (in.)	1.83	2.28	2.95	3.48
Ø E (in.)	0.98	1.30	1.57	1.81
Weight (lbs) standard version	0.67	1.39	2.70	4.81
Part No., without standard arm	CLR-1829-610E00	CLR-1829-620E00	CLR-1829-630E00	CLR-1829-640E00
Part No., with standard arm	CLR-1829-610E18	CLR-1829-620E24	CLR-1829-630E28	CLR-1829-640E33

Double Acting - With Position Monitoring*

B (in.)	2.62	3.21	3.94	4.41
Weight (lbs) standard version	0.63	1.27	2.53	4.18
Part No., without standard arm	CLR-1829-613D00	CLR-1829-623D00	CLR-1829-633D00	CLR-1829-643D00
Part No., with standard arm	CLR-1829-613D18	CLR-1829-623D24	CLR-1829-633D28	CLR-1829-643D33

Accessories

Part No., standard arm	CLR-0354-974	CLR-0354-975	CLR-0354-976	CLR-0354-977
Part No., long blank arm	CLR-0354-978	CLR-0354-979	CLR-0354-980	CLR-0354-981

Subject to change. For further details, including detailed dimensions and mounting instructions, visit roemheld-usa.com.



ROEMHELD
HILMA ■ STARK

Carr Lane Roemheld Mfg. Co.

Sales — Phone (314) 647-6200 Fax (314) 647-5736

Engineering — Phone 1-800-827-2526 Web roemheld-usa.com

Hinge Clamps ■ R-Series ■ B1.8251

Hinge Clamp ■ with metal wiper and optional position monitoring
Double Acting ■ Max. Operating Pressure ■ 3625 psi (250 bar)

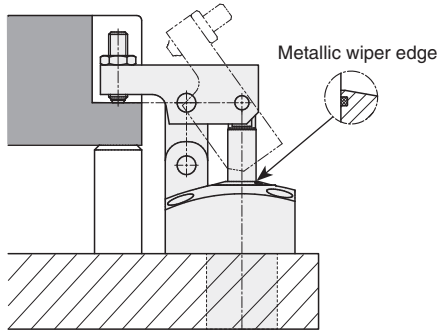
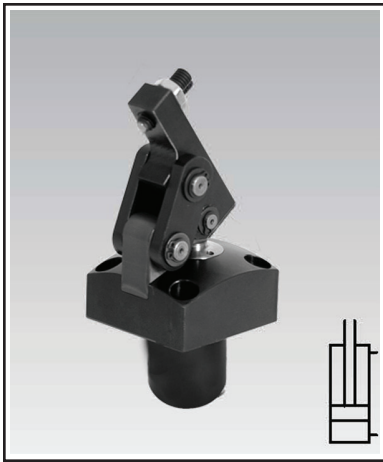

The hinge clamp family of workholding clamps offer many different variations in order to satisfy your fixturing goal. As the hydraulic piston moves upward, the hinge mechanism swivels the arm over your workpiece. The optimized design location of the pins and linkage can reduce or eliminate the transmission of side loading into your part. When retracted, the standard arm is behind the front plane of the clamp allowing for unobstructed top loading. It has a small footprint with large clamping force and FKM seals are standard. Metal wiper on piston rod and contoured top surface provides excellent protection from chips and coolant drainage for a long life cycle. Three sizes, three mounting options, and two arm options help the designer choose the optimal clamp for their application. The long arm can be machined to fit into pockets.

Other Manufacturers have uneven clamping forces

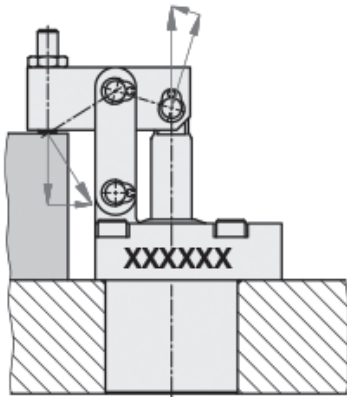

Roemheld gives you true vertical forces at the clamping point

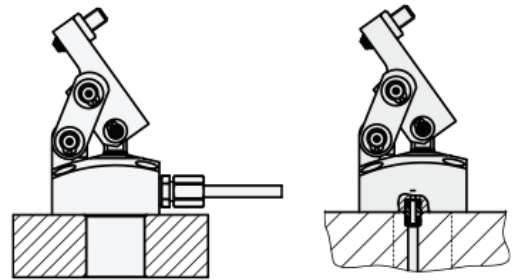
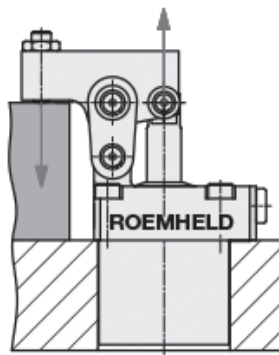

Standard Body comes with your choice of oil connection; fitting connection (left) or connecting insert (right)

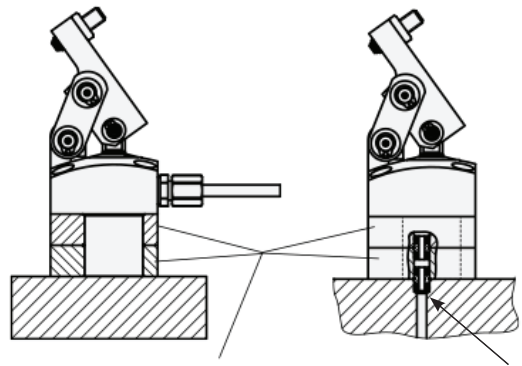
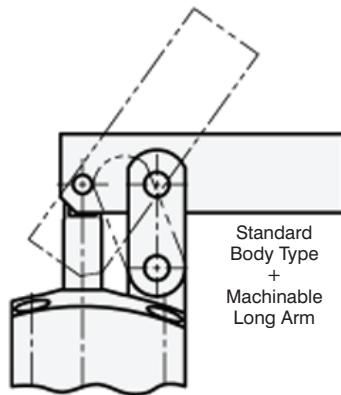
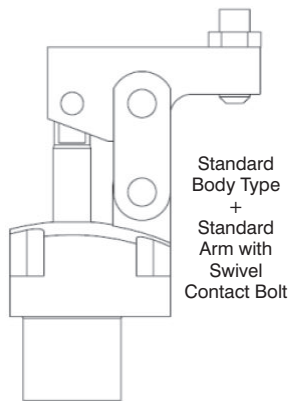

Intermediate Spacer Plates

Oil Connecting Insert

Subject to change. For further details, including detailed dimensions and mounting instructions, visit roemheld-usa.com.



Carr Lane Roemheld Mfg. Co.
 Sales — Phone (314) 647-6200 Fax (314) 647-5736
 Engineering — Phone 1-800-827-2526 Web roemheld-usa.com

Hinge Clamps ■ R-Series ■ B1.8251

Hinge Clamp ■ with metal wiper and optional position monitoring
Double Acting ■ Max. Operating Pressure ■ 3625 psi (250 bar)

Part Number Coding: **CLR-1825-X 3 0**

Size
1 = Size 1
2 = Size 2
3 = Size 3
4 = Size 4

Body Type
3 = STANDARD: Rear Fitting Connection OR Manifold connection via inserts

Arm Type
0 = STANDARD: Without clamping arm; Arms are sold separately

Other Body Types and Position Monitoring are available per data sheet B1.8251

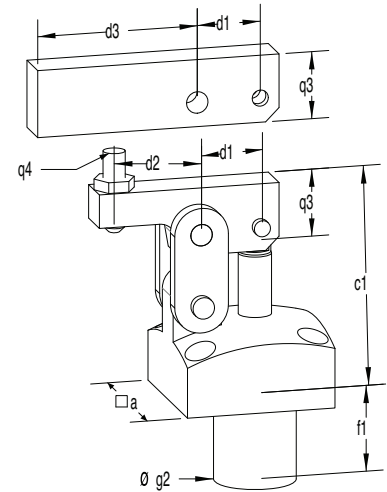

	Size 1	Size 2	Size 3	Size 4
Clamping Force (lbf) at max pressure, 3625 psi, and using standard clamping arm	900	2200	3200	5000
Effective Piston Area Extend (in ²)	0.312	0.761	1.247	1.948
Effective Piston Area Retract (in ²)	0.136	0.449	0.760	1.187
a (in)	2.165	2.756	3.346	3.937
c1 (in)	3.150	4.567	5.630	6.417
f1 (in)	1.260	1.693	1.752	2.067
g2 Ø (in)	1.173	1.646	2.039	2.551
q4	M8	M12	M16	M16
Part No. without arm	CLR-1825-130	CLR-1825-230	CLR-1825-330	CLR-1825-430

Arms (Sold Separately)

	Size 1	Size 2	Size 3	Size 4
d1 (in)	0.925	1.299	1.457	1.713
d2 standard arm only (in)	1.142	1.555	1.929	2.382
d3 long arm only (in)	2.343	3.209	3.858	4.488
q3 (in)	0.984	1.575	1.969	2.165
Standard Arm with swivel contact bolt	CLR-3548-510	CLR-3548-556	CLR-3548-587	CLR-3548-1035
Long Arm	CLR-3548-511	CLR-3548-557	CLR-3548-588	CLR-3548-1036

Accessories

	Size 1	Size 2	Size 3	Size 4
Intermediate spacer plate	CLR-3456-449	CLR-3456-468	CLR-3456-489	CLR-3456-534
Oil connecting insert	CLR-9210-145	CLR-9210-145	CLR-9210-145	CLR-9210-132

See data sheet B1.8251 for full technical details



ROEMHELD
HILMA ■ STARK

Carr Lane Roemheld Mfg. Co.
Sales — Phone (314) 647-6200 Fax (314) 647-5736
Engineering — Phone 1-800-827-2526 Web roemheld-usa.com

Why Carr Lane Roemheld Swing Clamps?

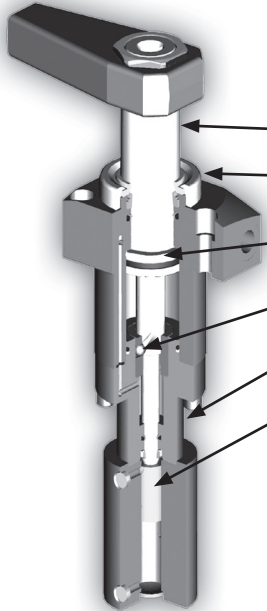

Designed for 1,000,000 cycles

2,000,000+ cycles tested at full load

- Rod diameter 30% larger to eliminate part deflection
- Viton wiper is standard (metal wiper optional)
- Exclusive safety clutch design available to prevent damage to part, fixture, or operator
- Reinforced swivel mechanism with 2 or 3 helix paths depending on size for longer life
- Up to 7500 psi maximum pressure for more compact clamp design
- Position monitoring available, either inductive or pneumatic via movable sensing bolt
- Over 1000 different standard sizes and styles available with clamping forces from 130 lb. to 8265 lb. stroke up to 2"
- Special stroke and clamping forces available upon request.

See Page 628-638

Versatile Modular Units For Assembly and Handling

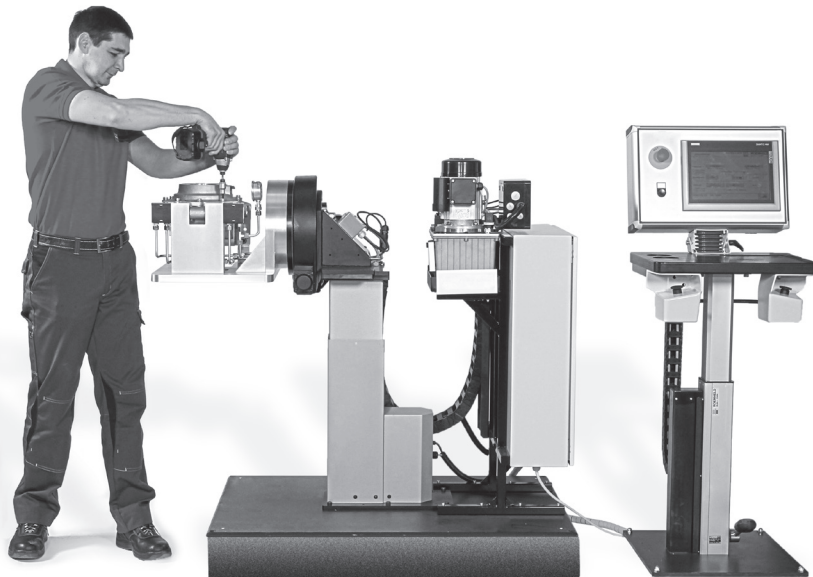

- Combine our modular units to Lift, Tilt, Rotate or Move your assembly
- Easily move your assembly to optimal position to increase productivity and reduce fatigue
- Preset positions for long runs or adjustable locations for flexibility

See Pages 734-735

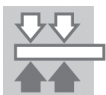

ROEMHELD
HILMA ■ STARK

Carr Lane Roemheld Mfg. Co.

Sales — Phone (314) 647-6200 Fax (314) 647-5736

Engineering — Phone 1-800-827-2526 Web roemheld-usa.com

Swing Clamps ■ Pneumatic ■ J7.201

Swing Clamps ■ All threaded and bottom flange type with pipe thread air connection
Double Acting ■ Max. Operating Pressure ■ 102 psi (7 bar)



The pneumatic swing clamp is a pull type cylinder where a part of the total stroke is used to swing the piston, for when it is essential to keep the clamping area free for unrestricted workpiece loading/unloading. Used in applications that require low clamping forces. Can be mounted in any position. The robust swing cam allows for maximum life. Five sizes, and two arm options help the designer

choose the optimal clamp for their application. The long arm can be machined to fit your application. Guide bushing, housing and flange are made of hardcoated aluminum and the piston rod is made of corrosion resistant steel.. Special swing angles are available. Electric position monitoring available and switching point can be adjusted to any point in the stroke range.

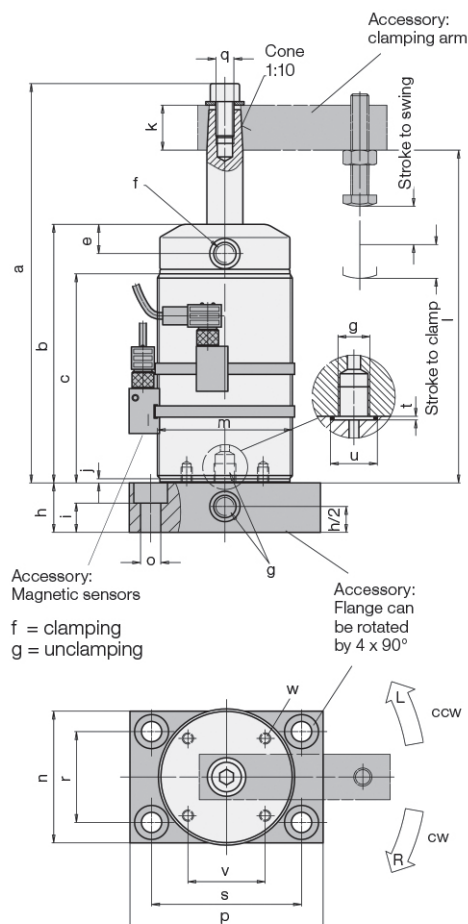

Max. clamping force with Standard Arm at 102 psi (lbs)	31	85	126	200	315
Piston Ø (in)	0.7874	1.2598	1.5748	1.9685	2.4803
Piston rod Ø (in)	0.3150	0.4724	0.6299	0.7874	0.9842
Stroke to swing (in)	0.2953	0.3740	0.6693	0.7087	0.9055
Stroke to clamp (in)	0.2756	0.3543	0.5905	0.5905	0.7087
Min. operating pressure (psi)	44				
Max. operating pressure (psi)	102				
Angle of rotation (°)	90° ± 2°				
Weight (kg)	0.44	0.66	1.54	1.98	4.63
a (in)	4.5000	5.2401	7.1890	7.8149	9.4685
b (in)	2.9527	3.4055	4.5275	4.9212	6.1417
c (in)	2.3031	2.6575	3.6614	3.9764	4.8819
e (in)	0.3740	0.4724	0.5118	0.5118	0.6693
f (in)	M5	M5	G 1/8	G 1/8	G 1/4
g (mm)	M5	M5	G 1/8	G 1/8	G 1/4
h (in)	0.4724	0.6299	0.8661	0.8661	0.9842
i (in)	0.2165	0.3740	0.5118	0.5118	0.5512
j (in)	0.0787	0.0787	0.0787	0.0787	0.0787
k (in)	0.4724	0.6299	0.7874	0.9842	1.1811
l (in)	3.8386	4.3110	6.0236	6.2598	7.7953
m (mm)	M30x1.5	M40x1.5	M50x1.5	M60x1.5	M80x1.5
n (in)	1.1811	1.4961	1.9685	2.2835	2.9527
o (in)	0.2598	0.2598	0.3543	0.3543	0.4331
p (in)	2.3622	2.5590	3.1496	3.3464	4.3307
q (mm)	M4	M6	M8	M12	M10
r (in)	0.6693	0.9055	1.1811	1.5748	2.1653
s (in)	1.6929	1.9685	2.3622	2.5984	3.4646
t (in)	0.0433	0.0433	0.0433	0.0433	0.0591
Øu (in)	0.3858	0.3858	0.5630	0.5630	0.7795
v (in)	0.5591	0.6929	1.0583	1.3386	1.5315
w (mm)	M4x5.5	M5x5	M5x7	M5x7	M8x10
Right swing direction 90 degree cw	CLR-1873-305	CLR-1874-303	CLR-1875-303	CLR-1876-303	CLR-1877-303
Left swing direction 90 degree ccw	CLR-1873-405	CLR-1874-403	CLR-1875-403	CLR-1876-403	CLR-1877-403
Accessory Flange	CLR-0345-403	CLR-0345-404	CLR-0345-405	CLR-0345-406	CLR-0345-407



ROEMHELD
HILMA ■ STARK

Carr Lane Roemheld Mfg. Co.
Sales — Phone (314) 647-6200 Fax (314) 647-5736
Engineering — Phone 1-800-827-2526 Web roemheld-usa.com

Swing Clamps ■ Pneumatic ■ J7.201

Swing Clamps ■ All threaded and bottom flange type with pipe thread air connection
Double Acting ■ Max. Operating Pressure ■ 102 psi (7 bar)

Seat of clamping arm (dimensions)

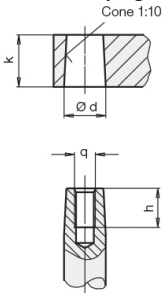

Swing clamp series	Ø d + 0.002	□k	h	q
CLR-1873-X05	0.3091	0.4724	0.3543	M4
CLR-1874-X03	0.4665	0.6299	0.5905	M6
CLR-1875-X03	0.6240	0.7874	0.7480	M8
CLR-1876-X03	0.7815	0.9842	0.7087	M12
CLR-1877-X03	0.9783	1.1811	0.9842	M10

Standard clamping arm

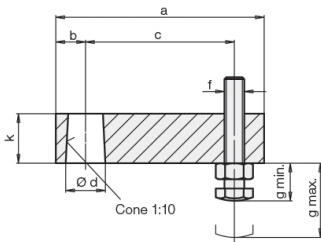

Swing clamp series	a	b	c	Ø d + 0.002	f	g min.	g max.	□k	Part No.
CLR-1873-X05	1.6535	0.2756	1.1811	0.3091	M4	0.3150	0.8071	0.4724	CLR-0187-324
CLR-1874-X03	2.0472	0.3937	1.3779	0.4665	M6	0.4724	0.6890	0.6299	CLR-0187-424
CLR-1875-X03	2.7559	0.4724	1.9685	0.6240	M6	0.4724	1.1220	0.7874	CLR-0187-524
CLR-1876-X03	3.2283	0.5512	2.3622	0.7815	M8	0.5905	0.9842	0.9842	CLR-0187-624
CLR-1877-X03	4.0945	0.7087	2.9527	0.9783	M10	0.7480	1.4370	1.1811	CLR-0187-724

Long machinable arm

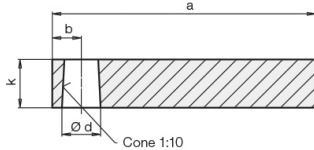

Swing clamp series	a	b	Ø d + 0.002	□k	Part No.
CLR-1873-X05	2.4409	0.2756	0.3091	0.4724	CLR-3548-355
CLR-1874-X03	2.8346	0.3937	0.4665	0.6299	CLR-3548-356
CLR-1875-X03	3.7401	0.4724	0.6240	0.7874	CLR-3548-357
CLR-1876-X03	4.5669	0.5512	0.7815	0.9842	CLR-3548-353
CLR-1877-X03	5.6299	0.7087	0.9783	1.1811	CLR-3548-358

Locking ring (flanged nut)

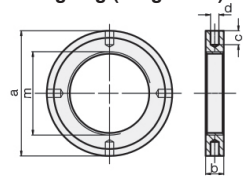

Swing clamp series	Øa	b	c	Ød (mm)	m	Part No.
CLR-1873-X05	1.9685	0.3937	0.2756	4 x 5	M30 x 1.5	CLR-3527-071
CLR-1874-X03	2.4409	0.4724	0.3150	4 x 6	M40 x 1.5	CLR-3527-040
CLR-1875-X03	2.9527	0.5118	0.3937	6 x 6	M50 x 1.5	CLR-3527-041
CLR-1876-X03	3.5433	0.5118	0.3937	6 x 6	M60 x 1.5	CLR-3527-042
CLR-1877-X03	4.5275	0.6299	0.4724	6 x 8	M80 x 1.5	CLR-3527-043

Threaded nut

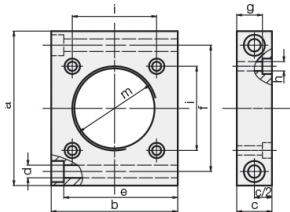

Swing clamp series	a	b	c	Ød	e	f	g	Øh	i	m	Part No.
CLR-1873-X05	2.5590	2.1653	0.5905	0.2165	1.9409	1.9685	0.4094	0.1772	1.1811	M30 x 1.5	CLR-3527-073
CLR-1874-X03	3.1496	2.5590	0.5905	0.2165	2.3346	2.3622	0.4094	0.1772	1.5748	M40 x 1.5	CLR-3527-044
CLR-1875-X03	3.7401	2.9527	0.7874	0.2598	2.6850	2.9527	0.5630	0.2165	1.9685	M50 x 1.5	CLR-3527-045
CLR-1876-X03	4.3307	3.5433	0.9842	0.3543	3.1890	3.5433	0.7165	0.2598	2.3622	M60 x 1.5	CLR-3527-046
CLR-1877-X03	5.5118	4.7244	0.9842	0.4331	4.2913	4.5275	0.6299	0.3543	2.9527	M80 x 1.5	CLR-3527-047

Contact bolts, dome head

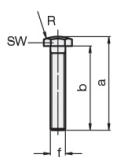

Swing clamp series	a	b	f	R	HEX (mm)	Part No.
CLR-1873-X05	1.2795	1.1811	M4	0.5905	7	CLR-3614-141
CLR-1874-X03	1.3189	1.1811	M6	0.7874	10	CLR-3614-137
CLR-1875-X03	1.9094	1.7716	M6	0.7874	10	CLR-3614-138
CLR-1876-X03	1.9685	1.7716	M8	0.7874	13	CLR-3614-139
CLR-1877-X03	2.6181	2.3622	M10	1.3779	17	CLR-3614-140

Swing Clamps

7250/3000 psi max
Single and double acting



Flange Base



All Threaded

- Popular series of swing clamps that provides many plumbing options
- Unique safety clutch prevents damage if arm strikes an object during swing
- Double-acting clamps are also available with longer clamping strokes (25mm or 50mm). Please contact factory.
- Choice of four sizes (3, 5, 6, and 7 series)

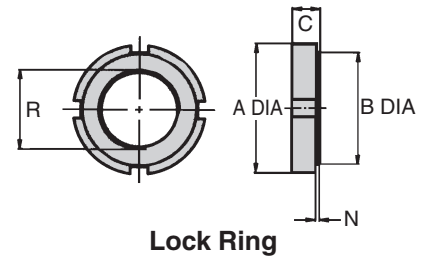

Lock Ring

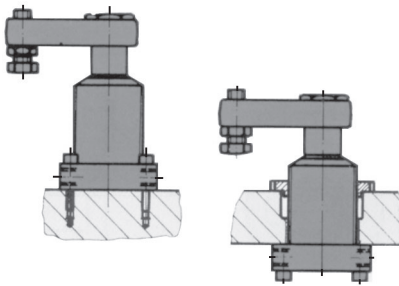

Version 1
Flange Base
Standard Fittings

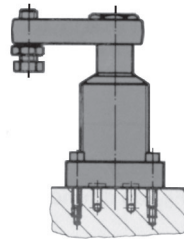

Version 2
Flange Base
Manifold Mounted

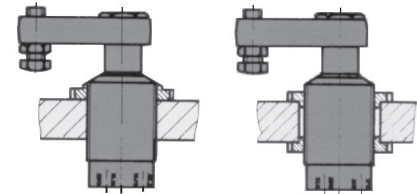

Version 3
All Threaded
Standard Fittings

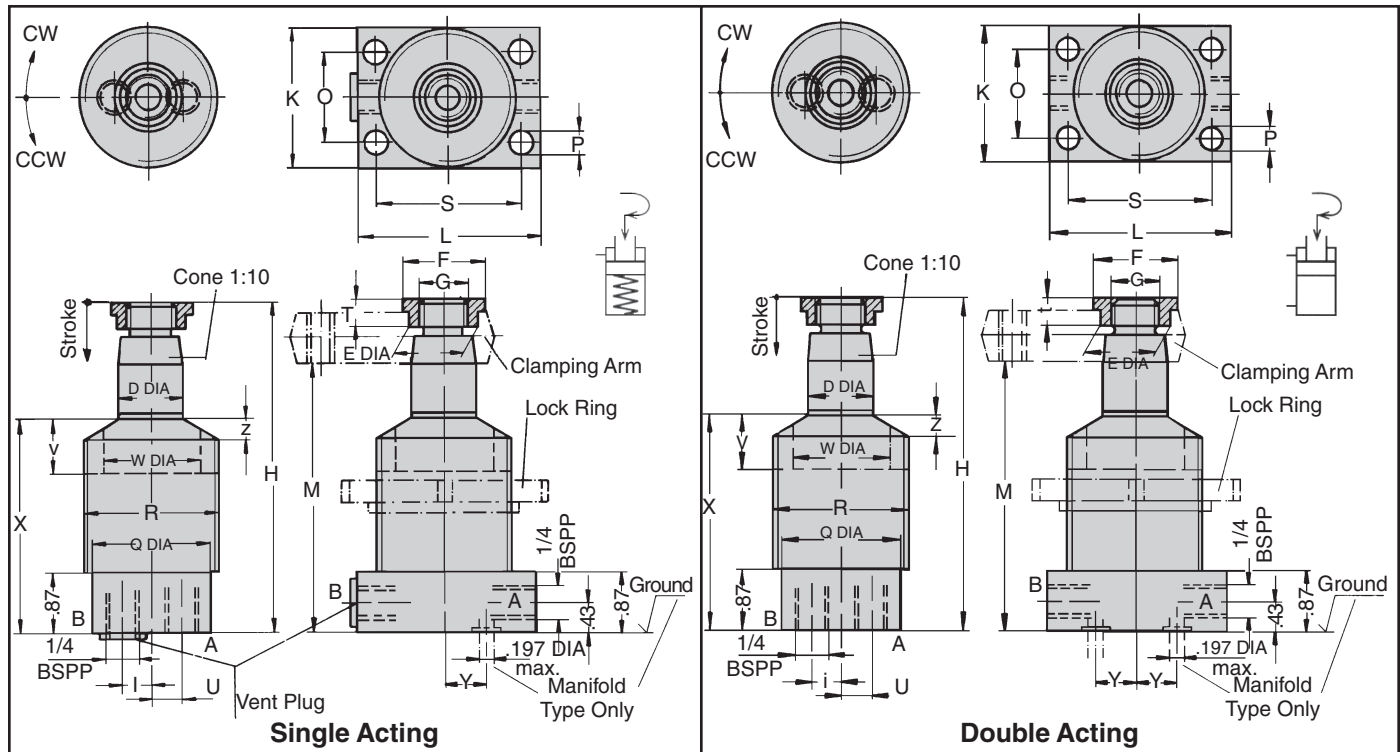

ROEMHELD
HILMA ■ STARK

Carr Lane Roemheld Mfg. Co.
Sales — Phone (314) 647-6200 Fax (314) 647-5736
Engineering — Phone 1-800-827-2526 Web roemheld-usa.com

Swing Clamps

7250/3000 psi max
Single and double acting

CLAMPING ACTION: Fluid pressure swings arm 90° over workpiece then clamps down. Spring return lifts arm then swings in back 90° for loading/unloading. Optional fluid return version (double-acting). Choose either clockwise or counterclockwise rotation to clamping position.

MOUNTING: Choose from many possible mounting methods: (1) Fasten to top of fixture plate with four capscrews inserted through flange base from above; (2) Mount through a hole in the fixture plate, fastening with four capscrews inserted through flange base from below; (3) Mount through a bored hole and secure with two lockings. Mount in any position, horizontal or vertical. Standard clamping arm requires a rear support.

DESIGN CONSIDERATIONS: The clamping arm must go through its full swing to operate properly. Stopping the arm short by obstructing it could possibly cause damage. Use low operating pressure during initial setting. May require a simple flow-control valve if fixture contains only a few clamps and is powered by a high-flow-rate power source. See power source pages to check. Cycle time must be at least one second.

STANDARD CLAMPING ARM: Rugged nodular iron arm pivots on a forged steel carrier. Arm can be mounted to start its 90° swing from any position within 360°. Contact bolt furnished.

OPTIONAL HALF ARM: Forged steel, furnished with contact bolt. Whenever possible, use standard clamping arms, with rear supports, for best mechanical leverage and full clamping force. Half arms are more compact and useful when there is no room for a rear support, but the maximum clamping force is greatly reduced. Half arms cause bending in the piston rods. This bending lowers the allowable maximum fluid pressure to 3000 psi. Exceeding 3000 psi can cause internal damage and decrease service life considerably. Arm extensions will further reduce the allowable operating pressure (inversely proportional to arm length.) To order Swing Clamps with half arms instead of standard arms, add an "H" to the part no.

FLUID CONNECTION: Male 37° tubing/hose connection (two with double-acting clamps). Do not use NPT fittings.

CONSTRUCTION: Sturdy helical-cam mechanism first rotates arm, then clamps. Integral safety clutch. Unit sealed to keep out dirt and chips.

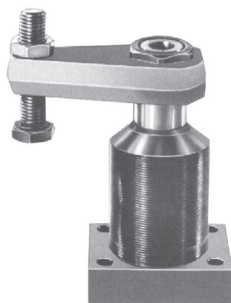

3000 psi maximum

Optional Half Arm

To order a Swing Clamp with a half arm instead of a standard pivoting arm, add on "H" to the part no. Example:

CLR-314-SC Standard Arm
CLR-314-SCH Half Arm

Clamping force (lbs) standard pivoting arm SA/DA (lbs)	7250 psi	1065/1080	2810/2845	4120/4495	7305/7490
	6000 psi	860/920	2200/2300	3400/3700	6000/6500
	5000 psi	710/770	1800/2000	2800/3100	4900/5500
	4000 psi	580/620	1480/1560	2340/2480	4030/4340
	3000 psi	400/450	960/1200	1600/1900	2800/3300
Clamping force half arm SA/DA (lbs) See pgs. 646-648 for special arm lengths	3000 psi	540/630	1320/1560	1700/2360	3360/3810
Clamping stroke		.43	.55	.59	.59
Stroke during swing		.28	.32	.43	.35
Fluid required to clamp (cu. in.)		.20	.61	1.12	1.69
Fluid required to unclamp, DA (cu. in.)		.54	1.69	3.11	4.60
Max. fluid flow rate (cu. in./min.)		11	36	67	101
Min. operating pressure (psi)		450	450	450	450
A Dia		2.68	3.54	4.53	5.12
B Dia		2.047/2.039	2.677/2.669	3.543/3.535	3.937/3.929
C		.47	.51	.63	.63
D Dia		.787	1.260	1.575	1.969
E Dia		.925	1.319	1.772	2.185
F Dia		1.18	1.57	2.17	2.68
G		M18 x 1.5	M28 x 1.5	M35 x 1.5	M45 x 1.5
H		4.98	5.81	6.77	7.17
I		.47	.49	.75	1.00
K		1.77	2.48	3.15	3.54
L		2.56	3.35	3.94	4.53
M (standard arm/half arm)		4.13/4.13	4.69/4.69	5.43/5.43	5.69/5.57
N		.12	.16	.20	.20
O		1.181	1.732	2.362	2.677
P Dia		.256	.335	.531	.630
Q Dia		1.69	2.28	3.03	3.46
R		M45 x 1.5	M60 x 1.5	M80 x 2	M90 x 2
S		1.969	2.559	3.150	3.543
T		.354	.394	.433	.472
U		.47	.77	1.04	1.34
V		.79	.79	1.18	1.57

Flange Base – Standard Fittings

Part No., Clamp without Arm	Single-Acting, CW	CLR-1883-104-SC	CLR-1885-104-SC	CLR-1886-104-SC	CLR-1887-104-SC
	Single-Acting, CCW	CLR-1883-204-SC	CLR-1885-204-SC	CLR-1886-204-SC	CLR-1887-204-SC
	Double-Acting, CW	CLR-1893-104-SCD	CLR-1895-104-SCD	CLR-1896-104-SCD	CLR-1897-104-SCD
	Double-Acting, CCW	CLR-1893-204-SCD	CLR-1895-204-SCD	CLR-1896-204-SCD	CLR-1897-204-SCD
Part No., Clamp with Standard Arm	Single-Acting, CW	CLR-314-SC	CLR-514-SC	CLR-614-SC	CLR-714-SC
	Single-Acting, CCW	CLR-324-SC	CLR-524-SC	CLR-624-SC	CLR-724-SC
	Double-Acting, CW	CLR-314-SCD	CLR-514-SCD	CLR-614-SCD	CLR-714-SCD
	Double-Acting, CCW	CLR-324-SCD	CLR-524-SCD	CLR-624-SCD	CLR-724-SCD

Flange Base – Manifold Mounted

Part No., Clamp without Arm	Single-Acting, CW	CLR-1883-504-SC	CLR-1885-504-SC	CLR-1886-504-SC	CLR-1887-504-SC
	Single-Acting, CCW	CLR-1883-604-SC	CLR-1885-604-SC	CLR-1886-604-SC	CLR-1887-604-SC
	Double-Acting, CW	CLR-1893-504-SCD	CLR-1895-504-SCD	CLR-1896-504-SCD	CLR-1897-504-SCD
	Double-Acting, CCW	CLR-1893-604-SCD	CLR-1895-604-SCD	CLR-1896-604-SCD	CLR-1897-604-SCD
Part No., Clamp with Standard Arm	Single-Acting, CW	CLR-354-SC	CLR-554-SC	CLR-654-SC	CLR-754-SC
	Single-Acting, CCW	CLR-364-SC	CLR-564-SC	CLR-664-SC	CLR-764-SC
	Double-Acting, CW	CLR-354-SCD	CLR-554-SCD	CLR-654-SCD	CLR-754-SCD
	Double-Acting, CCW	CLR-364-SCD	CLR-564-SCD	CLR-664-SCD	CLR-764-SCD



Carr Lane Roemheld Mfg. Co.

Sales — Phone (314) 647-6200 Fax (314) 647-5736

Engineering — Phone 1-800-827-2526 Web roemheld-usa.com

Swing Clamps

7250 psi max
Single and double acting

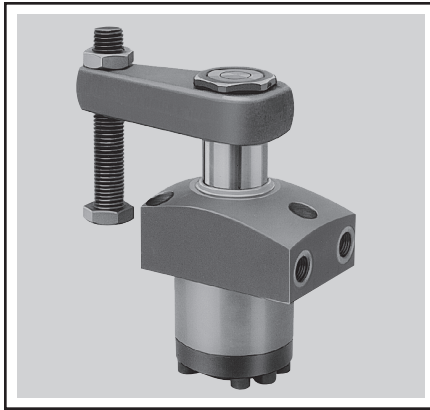

Top Flange

CLAMPING ACTION: Fluid pressure swings arm 90° over workpiece then clamps down. Spring return lifts arm then swings it back 90° for loading/unloading. Optional fluid return version (double-acting). Choose either clockwise or counterclockwise rotation to clamping position.

DESIGN CONSIDERATIONS: The clamping arm must go through its full swing to operate properly. Stopping the arm short by obstructing it could possibly cause damage. Use low operating pressure during initial setting. May require a simple flow-control valve if fixture contains only a few clamps and is powered by a high-flow-rate power source. See power source pages to check. Swing cycle time must be at least one second.

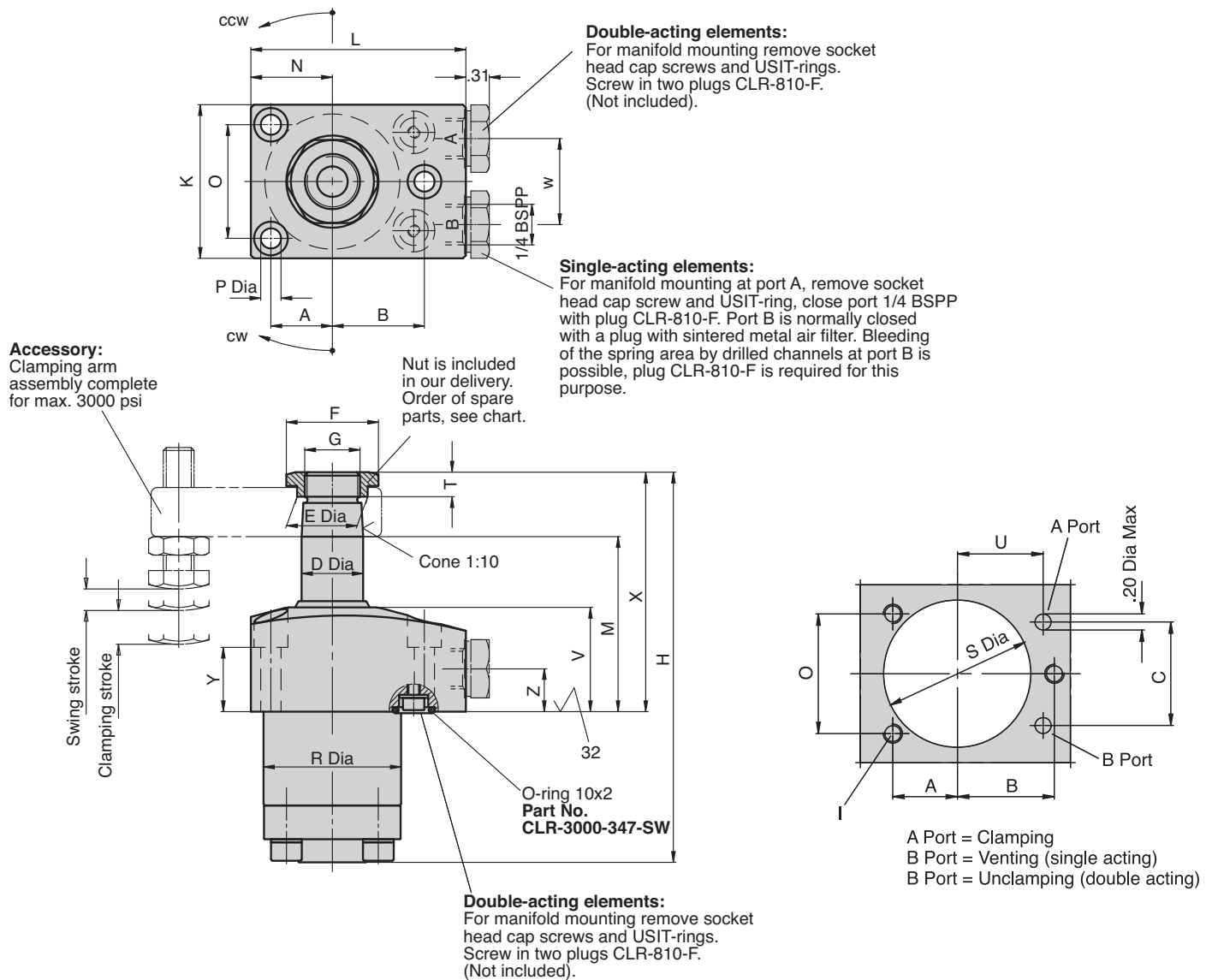

ROEMHELD
HILMA ■ STARK

Carr Lane Roemheld Mfg. Co.
Sales — Phone (314) 647-6200 Fax (314) 647-5736
Engineering — Phone 1-800-827-2526 Web roemheld-usa.com

Swing Clamps

7250 psi max
Single and double acting

Connecting possibilities

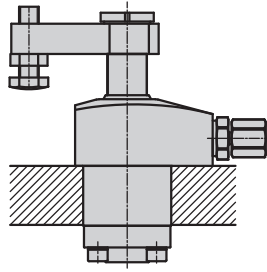

Tube connection

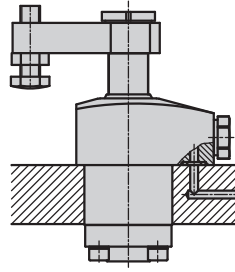

Top Flange with O-ring
sealing for manifold mounting

FLUID CONNECTION: 1/4 BSPP Port fittings with optional manifold mounting.

CONSTRUCTION: Sturdy helical-cam mechanism first rotates arm, then clamps. Integral safety clutch. Unit sealed to keep out dirt and chips.

INFO+: See pages 634-635 for arm options. Also available in 60° and 45° swing.

Clamping force (lbs) standard pivoting arm SA/DA (lbs)	7250 psi	1130/1125	2755/2845	4420/4495	7680/7865
	6000 psi	860/920	2200/2300	3400/3700	6000/6500
	5000 psi	710/770	1800/2000	2800/3100	4900/5500
	4000 psi	580/620	1480/1560	2340/2480	4030/4340
	3000 psi	400/450	960/1200	1600/1900	2800/3300
Clamping force half arm SA/DA (lbs) See pgs. 622-623 for special arm lengths	3000 psi	540/630	1320/1560	1700/2360	3360/3810
Clamping stroke		.43	.55	.59	.59
Swing stroke		.28	.31	.43	.35
Total stroke		.71	.86	1.02	.94
Operating pressure to swing min. (psi)		450	450	450	450
Max. oil flow rate (cu.in)		11	36	67	101
Oil to clamp (cu.in.)		.20	.61	1.12	1.69
Oil to return (cu.in.)		.54	1.69	3.11	4.58
D Dia		.787	1.260	1.575	1.969
A		.787	1.063	1.457	1.654
B		1.181	1.496	1.969	2.165
C		1.260	1.811	2.441	2.953
E Dia		.93	1.32	1.77	2.19
F		1.18	1.57	2.17	2.68
G		M18 x 1.5	M28 x 1.5	M35 x 1.5	M45 x 1.5
H		4.98	5.81	6.77	7.17
I		M6	M8	M10	M12
K		1.97	2.48	3.35	3.74
L		2.76	3.35	4.33	4.92
M		2.22	2.60	2.76	2.72
N		1.04	1.36	1.85	2.17
O		1.457	1.890	2.559	2.835
P Dia		.26	.35	.43	.55
R Dia		1.76	2.35	3.14	3.54
S Dia		1.79	2.38	3.17	3.56
T		.35	.39	.43	.47
U		1.043	1.220	1.575	1.772
V		1.34	1.57	1.57	1.57
W		1.10	1.61	2.17	2.76
X		3.07	3.70	4.09	4.29
Y		.83	.87	.59	.55
Z		.55	.55	.47	.47

Single Acting

Part No., Clockwise rotation	CLR-1883-103-SC	CLR-1885-103-SC	CLR-1886-103-SC	CLR-1887-103-SC
Part No., Counterclockwise rotation	CLR-1883-203-SC	CLR-1885-203-SC	CLR-1886-203-SC	CLR-1887-203-SC
Part No., 0 degree	CLR-1883-243-SC	CLR-1885-243-SC	CLR-1886-243-SC	CLR-1887-243-SC

Double Acting**

Part No., Clockwise rotation	CLR-1893-103-SCD	CLR-1895-103-SCD	CLR-1896-103-SCD	CLR-1897-103-SCD
Part No., Counterclockwise rotation	CLR-1893-203-SCD	CLR-1895-203-SCD	CLR-1896-203-SCD	CLR-1897-203-SCD
Part No., 0 degree	CLR-1893-243-SCD	CLR-1895-243-SCD	CLR-1896-243-SCD	CLR-1897-243-SCD

** Longer stroke versions available - Consult Engineering.



Carr Lane Roemheld Mfg. Co.

Sales — Phone (314) 647-6200 Fax (314) 647-5736

Engineering — Phone 1-800-827-2526 Web roemheld-usa.com

Swing Clamp Arms

7250 psi max
Single and double acting

Swing Clamp Part Number	Arm Size
CLR-3XX-SC(D)	Small
CLR-5XX-SC(D)	Medium
CLR-6XX-SC(D)	Large
CLR-7XX-SC(D)	Extra Large

Swing Clamp Part Number	Arm Size
CLR-18X3-XXX-SC(D)	Small
CLR-18X5-XXX-SC(D)	Medium
CLR-18X6-XXX-SC(D)	Large
CLR-18X7-XXX-SC(D)	Extra Large

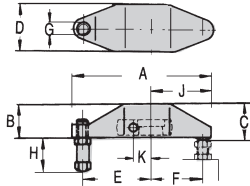
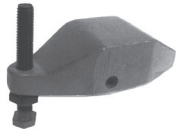

Standard Arm (Includes Carrier & Contact Bolt)

Size	Part No.	A	B	C	D	E	F	G	H	J	K
Small	CLR-0354-000-SCA	4.8	1.18	1.24	1.73	2.36	1.77	M10	.16-2.5	2.09	.57
Medium	CLR-0354-002-SCA	7.28	1.77	1.85	2.3	3.27	2.95	M16	.35-3.13	3.43	.88
Large	CLR-0354-041-SCA	8	2.13	2.22	3.23	3.62	3.23	M16	.35-3.75	3.74	1.1
Extra Large	CLR-0354-004-SCA	8.78	2.32	2.42	3.86	3.94	3.54	M20	.47-4.13	4.33	1.3

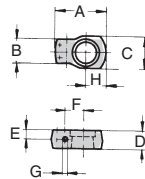

Carrier Only

Size	Part No.	A	B	C	D	E	F	G Dia.	H
Small	CLR-3542-093-SCA	1.81	1.02	1.26	0.63	0.33	0.57	.3150	0.63
Medium	CLR-3542-094-SCA	2.32	1.26	1.57	0.91	0.39	0.83	.3937	0.87
Large	CLR-3542-132-SCA	3.23	1.75	2.28	1.1	0.43	1.1	.4724	1.34
Extra Large	CLR-3542-096-SCA	3.54	2.2	2.68	1.34	0.51	1.3	.5512	1.42



Untapped Half Arm

Size	Part No.	A	B	C	D	F
Small	CLR-3921-016-SCA	2.95	.63	1.26	.63	.63
Medium	CLR-3921-017-SCA	4.53	0.87	1.89	0.91	0.98
Large	CLR-3921-021-SCA	5.51	1.1	2.36	1.1	1.18
Extra Large	CLR-3921-018-SCA	7.01	1.57	3.07	1.34	1.57

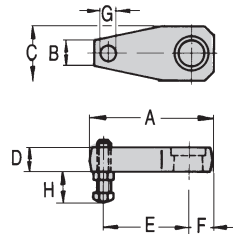

Tapped Half Arm (Includes Contact Bolt)

Size	Part No.	A	B	C	D	E	F	G	H
Small	CLR-0354-001-SCA	2.95	0.63	1.26	0.63	1.97	0.63	M10	.24-2.52
Medium	CLR-0354-003-SCA	4.53	0.87	1.89	0.91	2.95	0.98	M16	.36-3.11
Large	CLR-0354-042-SCA	5.51	1.1	2.36	1.1	3.74	1.18	M16	.36-3.11
Extra Large	CLR-0354-005-SCA	7.01	1.57	3.07	1.34	4.72	1.57	M20	.48-3.86



ROEMHELD
HILMA ■ STARK

Carr Lane Roemheld Mfg. Co.

Sales — Phone (314) 647-6200 Fax (314) 647-5736
Engineering — Phone 1-800-827-2526 Web roemheld-usa.com

Swing Clamp Arms

7250 psi max
Single and double acting

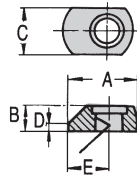

Short Arm

Size	Part no.	A	B	C	D	E
Small	CLR-3548-159-SCA	1.61	0.63	1.26	0.24	0.98
Medium	CLR-3548-165-SCA	2.4	0.91	1.89	0.24	1.46
Large	CLR-3548-304-SCA	2.99	1.1	2.36	0.43	1.77
Extra Large	CLR-3548-163-SCA	3.54	1.34	3.07	0.55	2.05

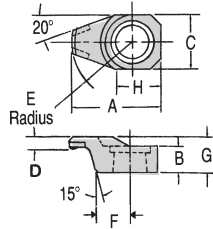

Thin Nose Arm

Size	Part no.	A	B	C	D	E	F	G	H
Small	CLR-3548-238-SCA	2.03	0.61	1.26	0.26	1.32	0.78	0.83	1.03
Medium	CLR-3548-236-SCA	2.99	0.89	1.81	0.35	1.97	0.88	1.1	1.31
Large	CLR-3548-301-SCA	3.94	1.1	2.6	0.43	2.52	1.72	1.34	1.94
Extra Large	CLR-3548-302-SCA	4.84	1.34	2.95	0.51	3.25	1.84	1.57	2.13

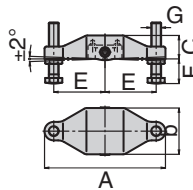
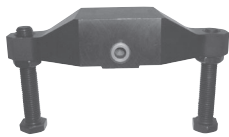

Double Arm (Includes Carrier & Contact Bolts)

Size	Part no.	A	B	C	D	E	F Max.
Small	CLR-0354-131-SCA	5.43	2.32	1.12	M10	2.36	2.52
Medium	CLR-0354-132-SCA	7.72	2.95	1.5	M16	3.27	3.11
Large	CLR-0354-133-SCA	8.5	3.35	1.85	M16	3.62	3.11
Extra Large	CLR-0354-134-SCA	9.29	4.13	2.2	M20	3.94	3.86

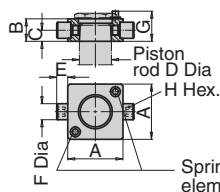
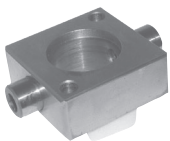

Carrier Only For Double-Arm

Size	Part no.	A	B	C	D Dia	E	F Dia	G*	H Hex
Small	CLR-0354-141-SCA	1.69	0.63	0.3	.79	0.35	0.39	0.85	M5
Medium	CLR-0354-142-SCA	2.17	0.91	0.43	1.26	0.43	0.63	1.14	M8
Large	CLR-0354-143-SCA	2.48	1.1	0.59	1.57	0.47	0.71	1.38	M8
Extra Large	CLR-0354-144-SCA	3.03	1.34	0.67	1.97	0.59	0.79	1.61	M8

*Stop for spring elements

Dimensions for Customer Manufactured Arms

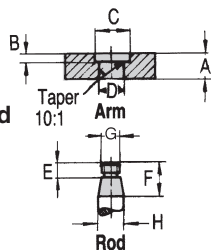

Customer Manufactured Arm

Clamp Size	A	B	C Dia.	D Dia (10:1 taper)	E	F	G	H Dia.
Small	0.63	0.16	0.94	.7815/.7835	0.39	0.83	M18x1.5	0.79
Medium	0.91	0.2	1.34	1.2539/1.2559	0.47	1.1	M28x1.5	1.26
Large	1.1	0.2	1.81	1.5689/1.5709	0.47	1.34	M35x1.5	1.57
Extra Large	1.34	0.24	2.2	1.9626/1.9646	0.51	1.57	M45x1.5	1.97



Swing Clamp Arm Options

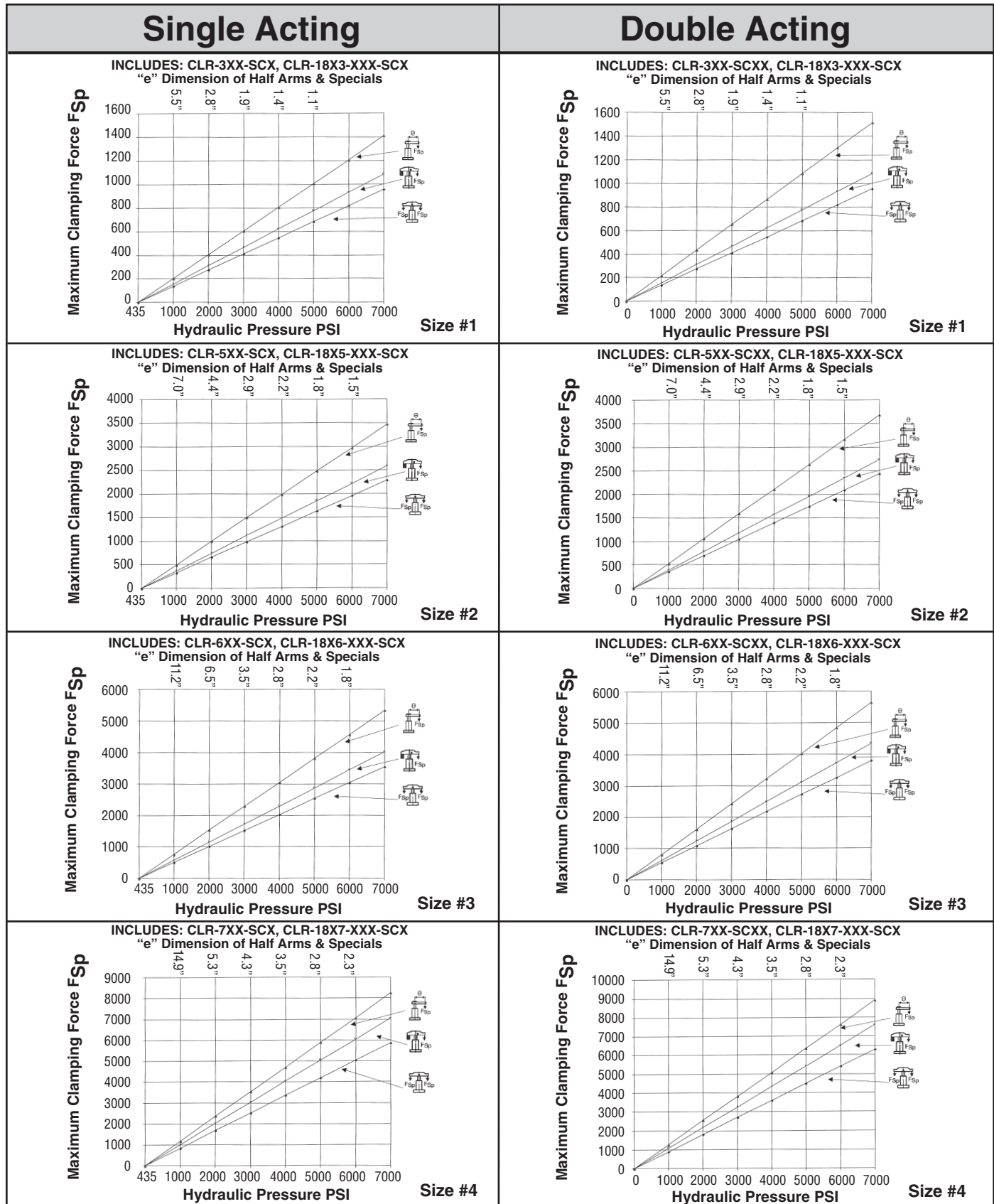

ROEMHELD
HILMA ■ STARK

Carr Lane Roemheld Mfg. Co.
Sales — Phone (314) 647-6200 Fax (314) 647-5736
Engineering — Phone 1-800-827-2526 Web roemheld-usa.com

Swing Clamps ■ R-Series ■ B1.853

Swing Clamps ■ Top flange type with pipe thread and manifold connection options
Double Acting ■ Max. Operating Pressure ■ 5075 psi (350 bar)

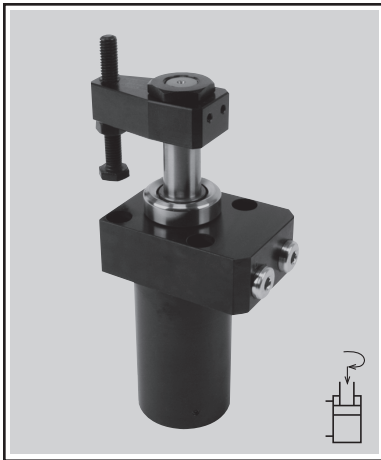

The hydraulic swing clamp is a pull type cylinder where a part of the total stroke is used to swing the piston, for when it is essential to keep the clamping area free for unrestricted workpiece loading/unloading. High clamping force at low pressures. Can be mounted in any position. The robust swing cam allows

for maximum life at the fastest swing speeds. Standard FKM seals. Special swing angle and indexing of clamp arm available. Multiple pneumatic and electric position monitoring available. Metallic wiper option. Four sizes allow the designer to choose the optimal clamp for their application.

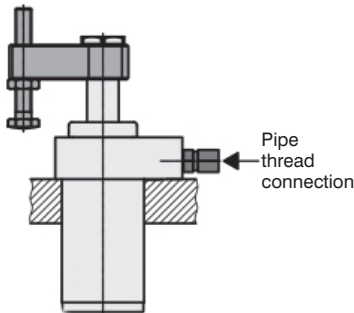
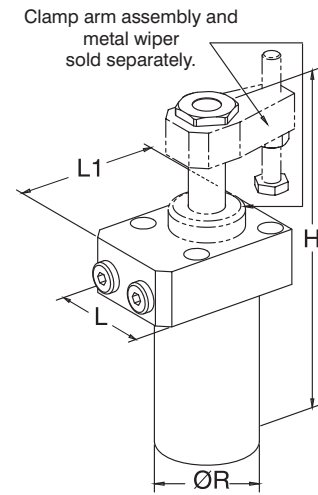
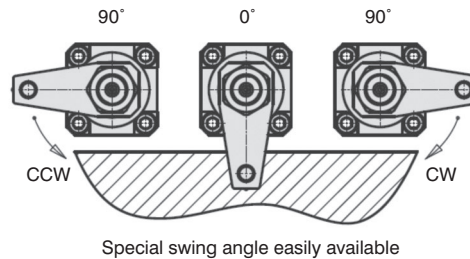
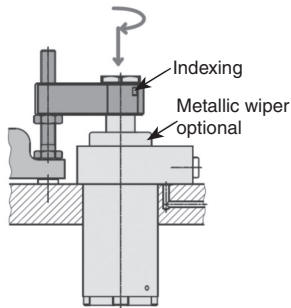

Clamping Force With Accessory Arm		Size 1	Size 2	Size 3	Size 4
Clamp Force (lbs)	5075 psi	1350	1888	3372	4946
	2000 psi	630	1012	1843	2698
	1000 psi	270	337	629	900

General Dimension specifications (in inches)

	Size 1	Size 2	Size 3	Size 4
L	2.17	2.48	3.03	3.35
L1	2.36	2.60	2.95	3.54
H	6.39	6.92	8.06	9.20
R Diameter	1.77	2.05	2.36	2.99
Clamping Stroke	0.47	0.47	0.59	0.59
Approx. Weight (Lbs)	3.75	5.07	8.60	13.23
Right Swing Direction 90 Degree CW	CAR-1843-A090-R23	CAR-1844-A090-R24	CAR-1845-A090-R30	CAR-1846-A090-R36
Left Swing Direction 90 Degree CCW	CAR-1843-A090-L23	CAR-1844-A090-L24	CAR-1845-A090-L30	CAR-1846-A090-L36
No Swing Direction 90 Degree CCW	CAR-1843-A000-023	CAR-1844-A000-024	CAR-1845-A000-030	CAR-1846-A000-036

Add "M" to the end of any part number to add metal wiper.

Accessories

	CLR-0354-152	CLR-0354-153	CLR-0354-154	CLR-0354-155
Standard Arm With Contact Bolt	CLR-0354-152	CLR-0354-153	CLR-0354-154	CLR-0354-155
Untapped Clamp Arm	CLR-3548-660	CLR-3548-661	CLR-3548-803	CLR-3548-804
Double Clamping Arm	CLR-7990-661	CLR-7990-662	CLR-7990-663	CLR-7990-664
Metallic Wiper	CLR-0341-104	CLR-0341-107	CLR-0341-105	CLR-0341-100

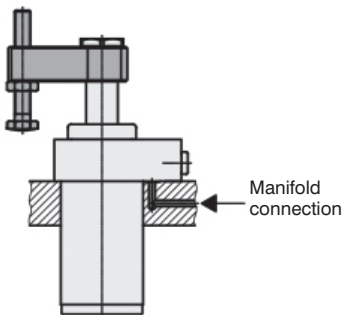

See data sheet B1.853 for full technical details



Carr Lane Roemheld Mfg. Co.
 Sales — Phone (314) 647-6200 Fax (314) 647-5736
 Engineering — Phone 1-800-827-2526 Web roemheld-usa.com

Swing Clamps ■ R-Series ■ B1.854

Swing Clamps ■ Bottom flange type with pipe thread and manifold oil connection options

Double Acting ■ Max. Operating Pressure ■ 5075 psi (350 bar)

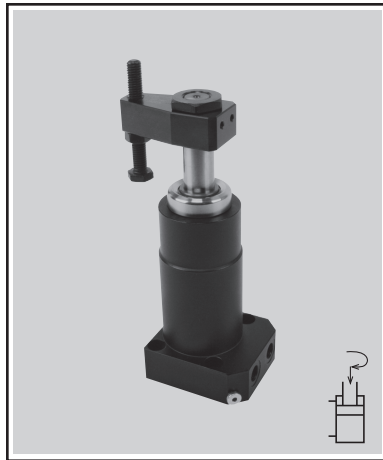

The hydraulic swing clamp is a pull type cylinder where a part of the total stroke is used to swing the piston, for when it is essential to keep the clamping area free for unrestricted workpiece loading/unloading. High clamping force at low pressures. Can be mounted in any position. The robust swing cam allows

for maximum life at the fastest swing speeds. Standard FKM seals. Special swing angle and indexing of clamp arm available. Multiple pneumatic and electric position monitoring available. Metallic wiper option. Four sizes allow the designer to choose the optimal clamp for their application.

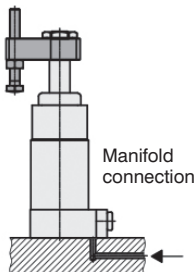
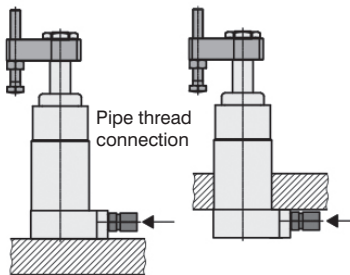
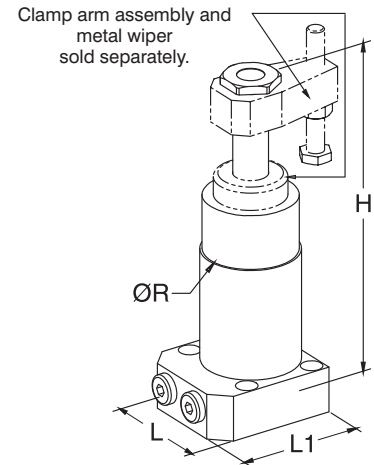
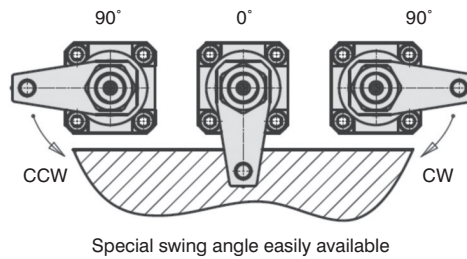
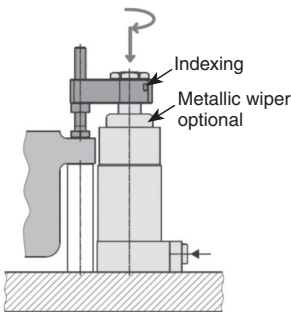

Clamping Force - Accessory Arm		Size 1	Size 2	Size 3	Size 4
Clamp Force (lbs)	5075 psi	1350	1890	3370	4945
	2000 psi	630	1010	1845	2700
	1000 psi	270	340	630	900

General Dimension Specifications (in inches)

	Size 1	Size 2	Size 3	Size 4
L	2.17	2.48	3.03	3.35
L1	2.36	2.60	2.95	3.54
H	6.39	6.92	8.06	9.20
R Diameter	1.77	2.05	2.36	2.99
Clamping Stroke	0.47	0.47	0.59	0.59
Approx. Weight (lbs.)	3.75	5.07	7.50	12.57
Right Swing Direction 90 Degree CW	CLR-1843-L090-R23	CLR-1844-L090-R24	CLR-1845-L090-R30	CLR-1846-L090-R36
Left Swing Direction 90 Degree CCW	CLR-1843-L090-L23	CLR-1844-L090-L24	CLR-1845-L090-L30	CLR-1846-L090-L36
No Swing 0 Degree	CLR-1843-L000-023	CLR-1844-L000-024	CLR-1845-L000-030	CLR-1846-L000-036

Add "M" to the end of any part number to add metal wiper.

Accessories

Standard Arm With Contact Bolt	CLR-0354-152	CLR-0354-153	CLR-0354-154	CLR-0354-155
Untapped Clamp Arm	CLR-3548-660	CLR-3548-661	CLR-3548-803	CLR-3548-804
Double Clamping Arm	CLR-7990-661	CLR-7990-662	CLR-7990-663	CLR-7990-664
Metallic Wiper	CLR-0341-104	CLR-0341-107	CLR-0341-105	CLR-0341-100

See data sheet B1.854 for full technical details.



ROEMHELD
HILMA ■ STARK

Carr Lane Roemheld Mfg. Co.
Sales — Phone (314) 647-6200 Fax (314) 647-5736
Engineering — Phone 1-800-827-2526 Web roemheld-usa.com

Push Clamps/Cylinders



Mini
page 625

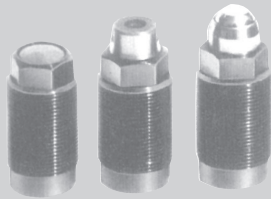

Single Acting
page 626

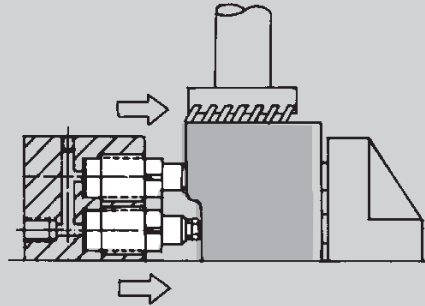

Threaded-Body Push Clamps

Achieve high force in a compact size. Wide variety of types and sizes. Various models offer different mounting options, such as using accessory brackets, screwing directly into fixture, or manifold mounting.

Accessories, page 643

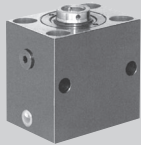

Block Clamps
pages 629-647

Block Clamps

Block Clamps are easy to mount horizontally or vertically on flat surfaces.

Available single and double acting, are excellent for punching and assembly operations, with high forces available. Wide range of sizes. Large sizes are often used for presswork applications (up to 180 tons).



**Threaded-Body
Universal Cylinder**
pages 631-632

Threaded-Body Universal Cylinder

Achieve space-saving mounting in fixture walls with this universal cylinder, in a wide range of sizes. Alternatively single acting with spring return or double acting.



Threaded-Body Push Clamps - Mini

7250/2300 psi max
Single acting



**Tube Mount
(Metric Only)**

Manifold Mount

- Can be mounted very close together
 - High force in a small size
 - Mount using accessory brackets or screw directly into fixture
 - Positive stroke stop and long plunger guide for superior reliability
 - Choice of five sizes
- **Do not use NPT fittings**

DESCRIPTION: These threaded body cylinders are particularly suitable for clamping of smaller workpieces in multiple clamping fixtures. Sealing is made by connecting directly to compression nut or by the included sealing washer. Multiple mounting options allow versatility when designing your fixture. Offered as flush mount piston or extended piston. High-speed cylinders are offered at a lower max. pressure.

IMPORTANT NOTES: These cylinders may not be subjected to load in the retracted position. The tube connection model has no stop for the tube, so it cannot be used for pre-mount of the compression sleeve. Please protect cylinders from chips and coolant.

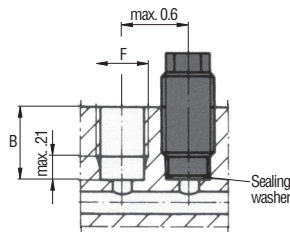
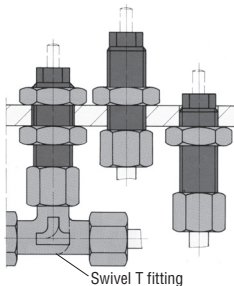
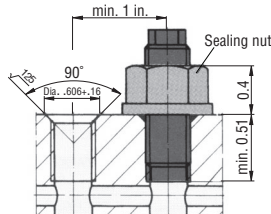
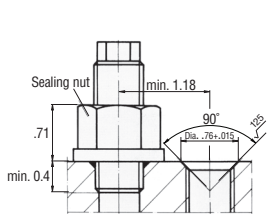
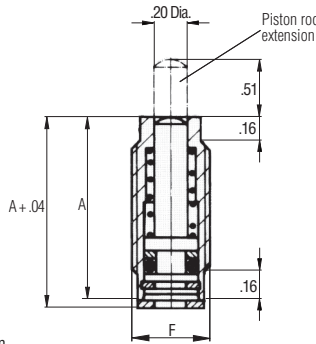
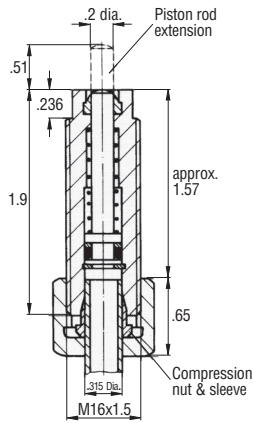
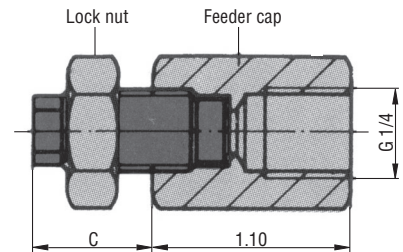
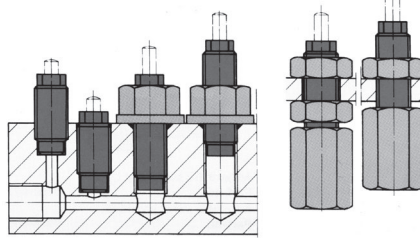

Clamping Force (lbs)	7250 psi	560	
	6000 psi	470	
	5000 psi	390	
	4000 psi	310	
	3000 psi	230	
Mounting Type	Tube Mount	Manifold Mount	
Stroke	0.39	0.197	0.39
Piston dia in.	0.315	0.315	0.315
Min psi	75	75	75
Spring return force (lbs)	3.4	3.4	3.4
A	—	1.06	1.57
B min/max	—	.43 / .95	.43 / 1.46
C	—	0.67	1.18
Seating torque (lbs)	8	8	8
Weight (lbs)	0.12	0.04	0.05

Inch			
F Thread	—	1/2 - 20	1/2 - 20
Part No.	—	CLR-801-TB	CLR-802-TB
Part No., Lock Nut	—	CLR-408-TBA	
Part No., Sealing Washer	—	CLR-3000-183-SW	
Part No., Sealing Nut	—	CLR-508-TBA	
Part No., Feeder Cap	—	CLR-308-TBA	
Part No., Mounting Block	—	CLR-108-TBA	

Metric			
F Thread	—	M12 X 1.5	M12 X 1.5
Part No.	CLR-1459-001-TB	CLR-1458-001-TB	CLR-1458-002-TB
Part No. with ext rod	CLR-1459-011-TB	CLR-1458-011-TB	CLR-1458-012-TB
Part No., High Speed 2300 psi max	CLR-1459-101-TB	CLR-1458-101-TB	CLR-1458-102-TB
Part No., High Speed w/ ext rod 2300 psi max	CLR-1459-111-TB	CLR-1458-111-TB	CLR-1458-112-TB
Part No., Lock Nut	CLR-3300-409-TBA	CLR-3300-408-TBA	
Part No., Sealing Washer	—	CLR-3000-036-SW	
Part No., Sealing Nut	CLR-3300-407-TBA	CLR-3300-406-TBA	
Part No., Swivel T Fitting	CLR-9208-035-F	—	
Part No., Swivel Elbow	CLR-9208-036-F	—	
Part No., Compression Nut	CLR-9208-100-F	—	
Part No., Compression Sleeve	CLR-9208-101-F	—	
Part No., Feeder Cap	—	CLR-3467-064-TBA	



ROEMHELD
HILMA ■ STARK

Carr Lane Roemheld Mfg. Co.
Sales — Phone (314) 647-6200 Fax (314) 647-5736
Engineering — Phone 1-800-827-2526 Web roemheld-usa.com

Threaded-Body Push Clamps - Standard Wiper

7250 psi max
Single acting

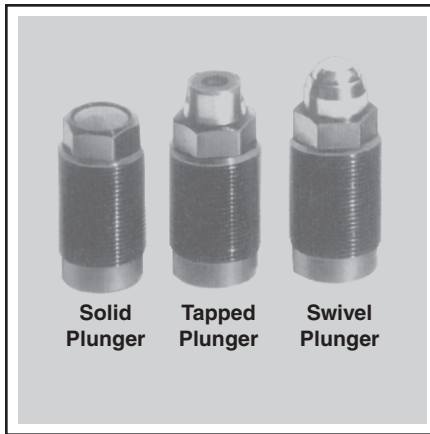

- Can be mounted very close together
 - High force in a small size
 - Mount using accessory brackets or screw directly into fixture
 - Positive stroke stop and long plunger guide for superior reliability
 - Choice of five sizes
- **Do not use NPT fittings

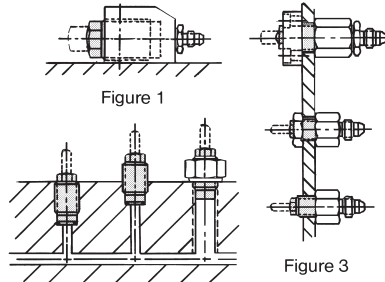

Figure 1
Figure 2
Figure 3
Mounting Options

See Threaded-Body Push Clamp accessories section

MOUNTING ON FIXTURE BASE: (Figure 1) Fasten mounting block to fixture. Screw clamp into block. (See table below for recommended seating torque. Sealing washer provided). Block has male 37° fluid connection.

MANIFOLD MOUNTING: (Figure 2) Screw clamp into tapped hole prepared as shown below. Supply fluid through passages drilled in fixture. Smallest size may be mounted with optional sealing nut. (Part no. CLR-508-TBA, 7/8 Hex. x. 46 thick).

MOUNTING THROUGH FIXTURE WALL: (Figure 3) (Through a tapped or bored hole). Secure clamp using optional locknut or mounting flange (two required for bored holes). Feeder cap required for fluid connection.

CONSTRUCTION: Steel plunger, case-hardened and ground. Positive stroke stop prevents over-extending the plunger. Long plunger guide provides support against side loads. Do not load plunger in its retracted position. Carbon steel body, black oxide finish.

PLUNGERS: Choose solid, tapped, or swivel plunger. Tapped plunger accepts contact bolts. Swivel plunger distributes force to prevent marring. Plunger extensions available by special order.

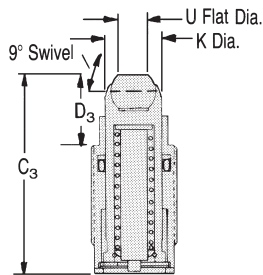
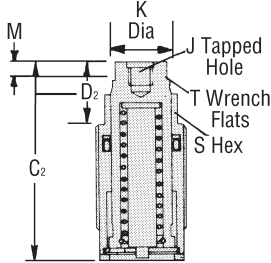
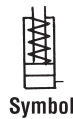
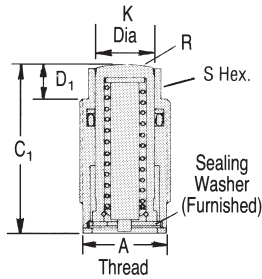

See F&A section for contact bolts

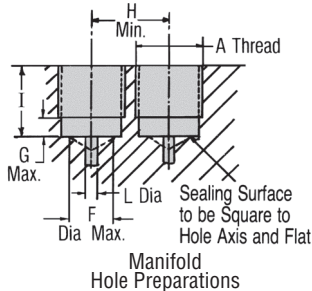

Clamping force (lbs)	7250 psi	1280	2270	3530	5530	8990
	6000 psi	1100	1900	2900	4500	7400
	5000 psi	900	1600	2400	3800	6200
	4000 psi	700	1200	1900	3000	5000
	3000 psi	500	900	1400	2300	3700
Max. clamping force (lbs)	1310	2340	3650	5700	9350	
Stroke	.38	.47	.59	.63	.78	
Fluid req'd (cu. in.)	.069	.147	.228	.479	.981	
Piston area (sq. in.)	.175	.312	.487	.760	1.247	
Force per 1000 psi (lbs)	175	312	487	760	1247	
Max. oper. pressure (psi)	7500	7500	7500	7500	7500	
A	7/8-14	1-1/8-12	1-1/4-16	1-1/2-16	1-7/8-16	
C ₁	1.50	1.81	2.19	2.34	3.44	
C ₂	1.78	2.06	2.59	2.69	3.88	
C ₃	1.80	2.09	2.73	2.86	—	
D ₁	.28	.38	.44	.53	.66	
D ₂	.56	.66	.81	.88	1.09	
D ₃	.56	.69	.97	1.05	—	
F dia	.47	.63	.78	1.00	1.25	
G	.31	.34	.34	.44	.50	
H	1.00	1.19	1.38	1.69	2.16	
I min.	.63	.78	.97	1.13	1.66	
I max.	1.53	1.41	1.75	1.81	2.75	
J	1/4-20x1/4	1/4-20x1/4	5/16-18x5/16	5/16-18x5/16	1/2-13x1/2	
K dia	.47	.63	.78	1.00	1.25	
L dia	.19	.19	.19	.19	.19	
M	.22	.22	.25	.28	.34	
R	.75	1.00	1.25	1.56	2.00	
S	.69	.94	1.69	1.25	1.69	
T	.38	.50	.63	.75	.94	
U	.28	.28	.41	.41	—	
Seating torque (ft.-lbs)	29	36	43	58	163	
Weight (lbs)	.18	.33	.48	.48	2.13	
Part No., solid plunger	CLR-000-TB	CLR-100-TB	CLR-200-TB	CLR-300-TB	CLR-400-TB	
Part No., tapped plunger	CLR-001-TB	CLR-101-TB	CLR-201-TB	CLR-301-TB	CLR-401-TB	
Part No., swivel plunger	CLR-010-TB	CLR-110-TB	CLR-210-TB	CLR-310-TB	—	
Spare sealing washer	CLR-3000-840-SW	CLR-3000-179-SW	CLR-3000-180-SW	CLR-3000-843-SW	CLR-3000-181-SW	



Carr Lane Roemheld Mfg. Co.
Sales — Phone (314) 647-6200 Fax (314) 647-5736
Engineering — Phone 1-800-827-2526 Web roemheld-usa.com

Threaded-Body Push Clamps

Application Examples

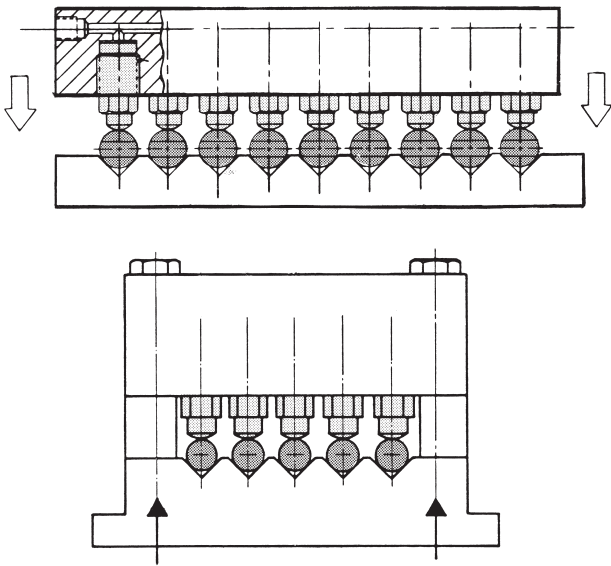

V-block fixtures allow very close workpiece spacing. Bottom example shows bridging bolt parallel to, and in the same plane as, the push clamps. This eliminates bending moments in the fixture.

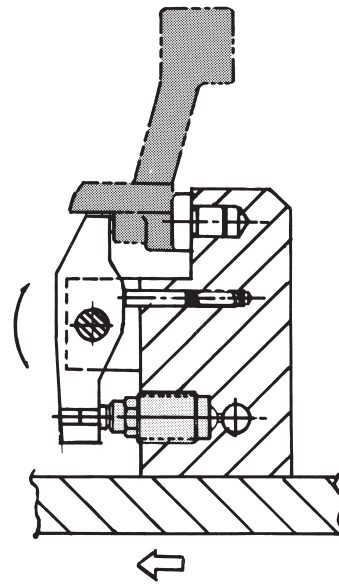

Custom clamping unit made using a pivoting lever with a return spring. By altering the lever ratio, you can make workpiece contact greater or less than clamp force.

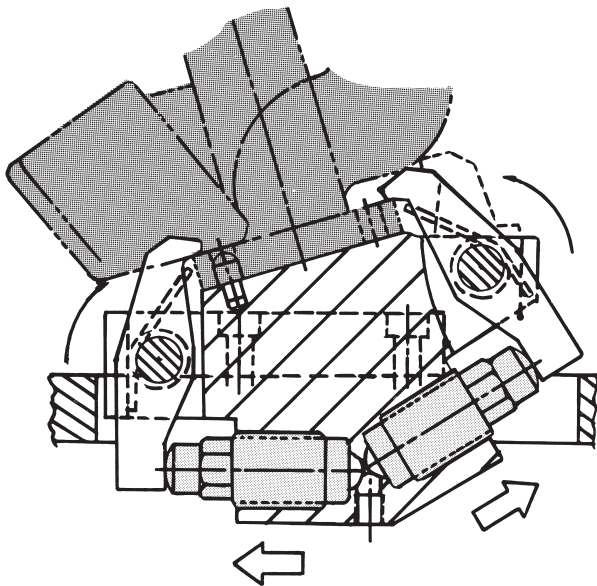

Twin clamping levers hold an exhaust manifold under extreme space limitations. Clamps are almost totally clear of workpiece area.

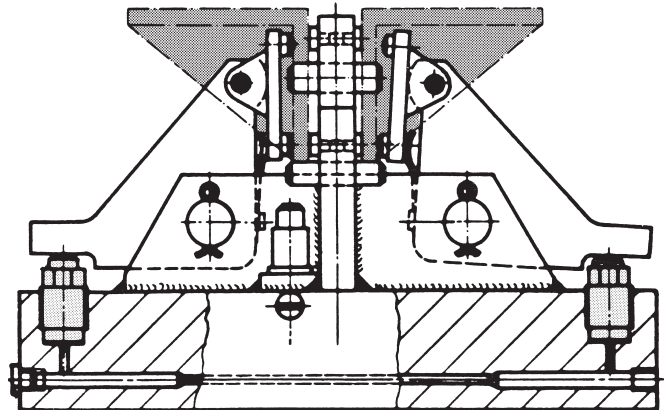

Pivoting levers clamp two angle brackets against a central locator. Each lever also has a pivoting contact pad to distribute clamping force evenly.



ROEMHELD
HILMA ■ STARK

Carr Lane Roemheld Mfg. Co.
Sales — Phone (314) 647-6200 Fax (314) 647-5736
Engineering — Phone 1-800-827-2526 Web roemheld-usa.com

Threaded-Body Push Clamp Accessories

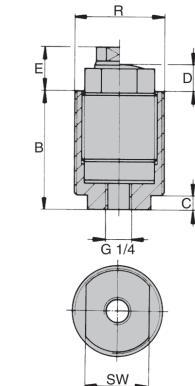
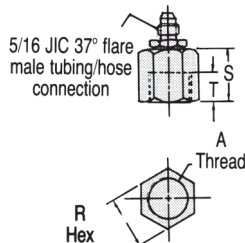
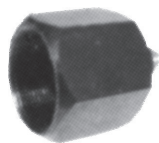
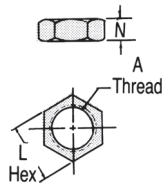
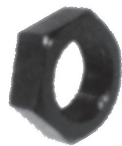
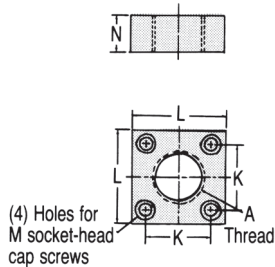
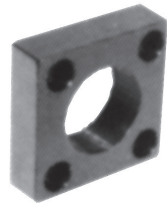
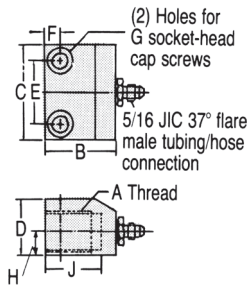
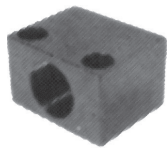

Mounting Blocks — Inch

A	1/2-20	7/8-14	1-1/8-12	1-1/4-16	1-1/2-16	1-7/8-16
B	1.63	1.75	2.00	2.25	2.38	3.25
C	1.50	2.25	2.75	3.00	3.50	4.00
D	1.00	1.25	1.50	1.75	2.00	2.50
E	1.00	1.50	1.88	2.00	2.38	2.75
F	.25	.38	.44	.50	.56	.63
G Dia.	1/4-20	5/16-18	3/8-16	1/2-13	1/2-13	5/8-11
H	.50	.56	.75	.75	1.00	1.25
J	.94	1.22	1.41	1.75	1.81	2.75
Part No.	CLR-108-TBA	CLR-100-TBA	CLR-101-TBA	CLR-102-TBA	CLR-103-TBA	CLR-104-TBA

Mounting Flanges — Inch

A	1-1/4 - 16	1-1/2 - 16	1-7/8 - 16
K	1.56	1.75	2.13
L	2.25	2.5	3.00
M	5/16 - 18	5/16 - 18	3/8 - 16
N	.88	1.00	1.25
Part No.	CLR-202-TBA	CLR-203-TBA	CLR-204-TBA

Jam Nuts — Inch

A	1/2 - 20	7/8 - 14	1-1/8 - 12
L	.75	1.94	1.69
N	.31	.50	.63
Part No.	CLR-408-TBA	CLR-400-TBA	CLR-401-TBA

Jam Nuts — Metric

A	M 28 X 1.5	M 32 X 1.5	M 38 X 1.5	M 45 X 1.5	M 60 X 1.5
L	50	62	58	68	90
N	10	11	11	12	13
Part No.	CLR-3301-423-TBA	CLR-3301-019-TBA	CLR-3300-088-TBA	CLR-3300-326-TBA	CLR-3300-411-TBA

Feeder Caps — Inch

A	1/2-20	7/8-14	1-1/8-12	1-1/4-16	1-1/2-16	1-1/2-16
R	.75	1.13	1.38	1.50	1.75	1.75
S	.63	1.13	1.25	1.44	1.63	1.63
T	.44	.63	.78	.97	1.13	1.13
Part No.	CLR-308-TBA	CLR-300-TBA	CLR-301-TBA	CLR-302-TBA	CLR-303-TBA	CLR-304-TBA

Feeder Caps — Metric

Fits	CLR-1460-0XX-TB	CLR-1461-0XX-TB	CLR-1462-0XX-TB	CLR-1463-0XX-TB	CLR-1464-0XX-TB
A	M 22 X 1.5	M 26 X 1.5	M 30 X 1.5	M 38 X 1.5	M 48 X 1.5
B	44	49	58	59	85
C	7	7	7	7	8
D	7	10	11	13.5	17
E	14	16.5	20.5	22.5	28
R	M 28 X 1.5	M 32 X 1.5	M 38 X 1.5	M 45 X 1.5	M 60 X 1.5
SW	22	24	27	32	41
Part No.	CLR-3467-084-TBA	CLR-3467-085-TBA	CLR-3467-086-TBA	CLR-3467-087-TBA	CLR-3467-093-TBA



Block Clamps

7250 psi max
Single and double acting

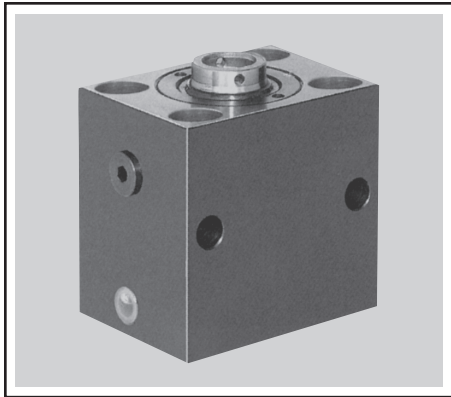

- Easy to mount on flat surfaces
- Excellent for punching and assembly operations (very high forces available)
- Mount either horizontally or vertically
- Available with short or long stroke
- Choice of eight sizes
- Do not use NPT fittings

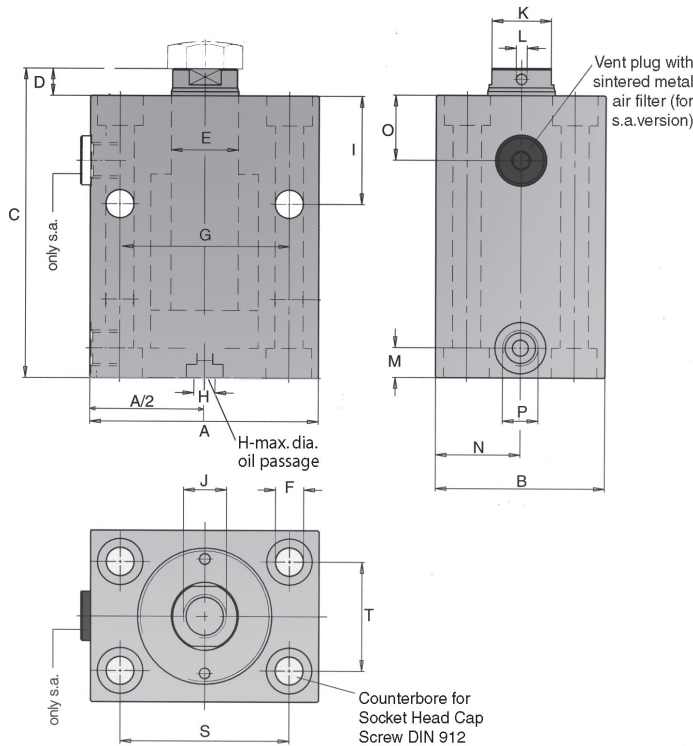
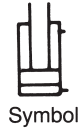
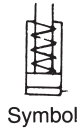

CLAMPING ACTION: Fluid pressure advances plunger. Spring return. Optional fluid-return version (double-acting).

STROKE LENGTH: Short-stroke version is more compact. Choose it whenever possible. Longer strokes than listed below are available in all sizes...please contact factory.

MOUNTING: Either fasten with long cap screws through the block and threaded into fixture, or tap holes in block to accept screws. See below for locations to drill additional holes if desired. If clamping thrust is not backed up by the fixture, a support should be provided to prevent slight screw shifting in the mounting holes...see example below. Support may be a rectangular strip or dowel pins (height should be at least 1/3 of B dimension). Male 37° fluid connection (two with double-acting clamps).

CONSTRUCTION: Steel plunger, case hardened and ground. Body made from carbon steel, or nodular iron in larger sizes. Spring-return versions have a sintered-metal vent filter to keep out dirt. If flood coolant could enter through the vent, replace vent filter with a CLR-815-AF air-vent fitting.

ACCESSORIES: Contact bolts for plunger recommended...see F&A section.

OPTIONAL VITON SEALS: For high-temperature applications (up to 300°F maximum) we offer viton seals as an option in all sizes. Please contact factory for more information.

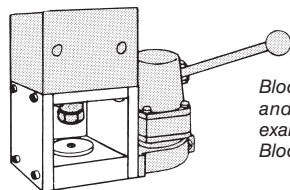
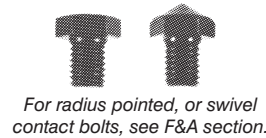
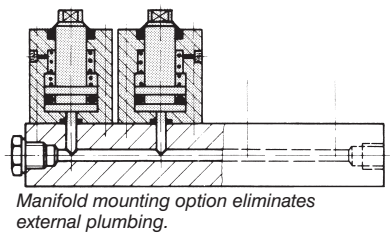
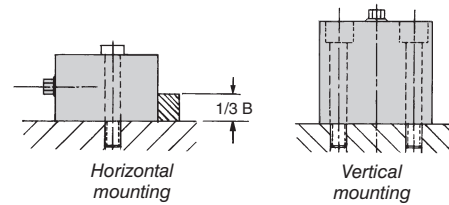

Block Clamps are ideal for punching and assembly operations. In this example, a small press is made using a Block Clamp and Hand Pump.

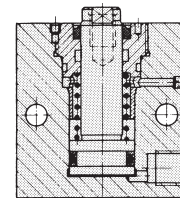

ROEMHELD
HILMA ■ STARK

Carr Lane Roemheld Mfg. Co.
Sales — Phone (314) 647-6200 Fax (314) 647-5736
Engineering — Phone 1-800-827-2526 Web roemheld-usa.com

Block Clamps

7250 psi max
Single and double acting

Clamping force (lbs)	7250 psi	2250	5505	9035	14120	22145	35070	56650	88125
	6000 psi	1900	4600	7500	11700	18300	29000	46900	72900
	5000 psi	1600	3800	6200	9700	15300	24200	39100	60800
	4000 psi	1200	3000	5000	7800	12200	19300	31300	48600
	3000 psi	900	2300	3700	5800	9200	14500	23400	36500
Piston Area (sq. in.)	.312	.760	1.247	1.950	3.050	4.833	7.791	12.150	
Max. Oper. Pressure (psi)	7500	7500	7500	7500	7500	7500	7500	7500	
A	2.38	2.56	2.97	3.34	3.94	4.94	6.31	7.88	
B	1.38	1.75	2.19	2.50	2.94	3.75	4.75	5.94	
C short stroke	2.44	2.81	3.34	3.50	3.94	4.56	5.19	5.69	
C long stroke	3.81	4.00	4.34	4.50	4.94	5.88	7.06	8.06	
D	.22	.28	.38	.38	.38	.56	.56	.59	
E dia.	.39	.63	.79	.98	1.26	1.57	1.97	2.48	
F dia. screw	1/4	5/16	3/8	3/8	7/16	5/8	3/4	7/8	
G	1.181	1.969	2.165	2.480	2.992	3.740	4.724	6.220	
H dia.	.19	.19	.19	.19	.19	.31	.31	.31	
I	1.19	1.31	1.50	1.56	1.75	1.97	2.38	2.50	
J	1/4-20 x 15/32	3/8-16 x 19/32	1/2-13 x 19/32	5/8-11 x 31/32	3/4-10 x 1-3/16	1-8 x 1-9/16	M30x40	M42x60	
K	.31	.50	.63	—	—	—	—	—	
L dia.	—	—	—	.16	.16	.16	.19	.22	
M	.44	.44	.44	.44	.50	.66	.81	1.00	
N	.69	.88	1.09	1.25	1.47	1.88	2.38	2.94	
O	.66	.72	.88	.94	1.06	1.03	1.31	1.38	
P-Port size	G1/4	G1/4	G1/4	G1/4	G1/4	G1/2	G1/2	G1/2	
S	1.575	1.969	2.165	2.480	2.992	3.740	4.724	6.220	
T	.866	1.181	1.378	1.575	1.772	2.559	3.150	4.252	
Weight, short stroke (lbs.)	1.8	2.6	4.0	5.7	8.4	14.7	28.2	52.8	
Weight, long stroke (lbs.)	1.9	4.2	5.9	7.9	11.6	21.5	43.6	81.4	

Single Acting — Inch

Stroke, short	.31	.31	.38	.38	.47	.47	.47	.47
Stroke, long	.78	.78	.78	.78	.78	1.0	1.25	1.25
Fluid reqd., short (cu. in.)	.10	.24	.48	.73	1.37	2.26	3.68	5.75
Fluid reqd., long (cu. in.)	.23	.57	.94	1.46	2.29	4.83	9.81	15.34
Spring return force (lbs)	11	31	44	61	92	97	170	270
Part No. short stroke	CLR-1511-705	CLR-1513-705	CLR-1514-705	CLR-1515-705	CLR-1516-705	CLR-1517-705	—	—
Part No. long stroke	CLR-1511-725	CLR-1513-725	CLR-1514-725	CLR-1515-725	CLR-1516-725	CLR-1517-735	—	—
Part No. short stroke, manifold mount	CLR-1511-705B	CLR-1513-705B	CLR-1514-705B	CLR-1515-705B	CLR-1516-705B	CLR-1517-705B	—	—

Single Acting — Metric

J x Depth of thread	M6 x 12	M10 x 15	M12 x 15	M16 x 25	M20 x 30	M27 x 40	M30 x 40	M42 x 60
Part No. short stroke	CLR-1511-005	CLR-1513-005	CLR-1514-105	CLR-1515-005	CLR-1516-005	CLR-1517-005	CLR-1518-005	CLR-1519-005
Part No. long stroke	CLR-1511-025	CLR-1513-025	CLR-1514-125	CLR-1515-025	CLR-1516-025	CLR-1517-035	CLR-1518-045	CLR-1519-045
Part No. short stroke, manifold mount	CLR-1511-005B	CLR-1513-005B	CLR-1514-105B	CLR-1515-005B	CLR-1516-005B	CLR-1517-005B	CLR-1518-005B	CLR-1519-005B

Double Acting — Inch

Stroke, short	0.63	.78	1.00	1.00	1.00	1.19	1.25	1.56
Stroke, long	2.0	2.00	2.00	2.00	2.00	2.50	3.13	3.94
Fluid reqd., short (cu. in.)	.20	.57	1.25	1.95	3.05	5.74	9.81	19.17
Fluid reqd., long (cu. in.)	.62	1.52	2.50	3.90	6.10	12.08	24.54	47.93
Return piston area	.190	.448	.759	1.187	1.796	2.882	4.748	7.342
Part No. short stroke	CLR-1541-705	CLR-1543-705	CLR-1544-705	CLR-1545-705	CLR-1546-705	CLR-1547-705	—	—
Part No. long stroke	CLR-1541-765	CLR-1543-765	CLR-1544-765	CLR-1545-765	CLR-1546-765	CLR-1547-775	—	—

Double Acting — Metric

J x Depth of Thread	M6 x 12	M10 x 15	M12 x 15	M16 x 25	M20 x 30	M27 x 40	M30 x 40	M42 x 60
Part No. short stroke	CLR-1541-105	CLR-1543-105	CLR-1544-105	CLR-1545-105	CLR-1546-105	CLR-1547-105	CLR-1548-105	CLR-1549-105
Part No. long stroke	CLR-1541-165	CLR-1543-165	CLR-1544-165	CLR-1545-165	CLR-1546-165	CLR-1547-175	CLR-1548-185	CLR-1549-195

Larger sizes and strokes available (metric only).



Threaded-Body Universal Cylinder

7250 psi max
Single and double acting



- 6 piston diameters from 16 up to 63mm
- 3 different strokes per size
- Sealing with very little leakage
- Alternatively single acting with spring return or double acting
- Ports 1/4 BSPP at the cylinder bottom
- Axial regulation due to external thread
- Lock nuts as per DIN 1804 can be used
- Space-saving mounting in fixture walls
- Piston rod with internal thread for fixing of different contact bolts

DESCRIPTION: The threaded-body universal cylinders are delivered with the same piston diameters and strokes as the well-proven block cylinders. Hydraulic connection is exclusively effected at the cylinder bottom by hydraulic tubes or hoses.

Sealing of the case-hardened piston rod is made by a tandem sealing with minimum leakage and a wiper.

APPLICATION: The threaded-body universal cylinders can be used as clamping cylinders for workpiece clamping as well as for general motion tasks.

For temperatures exceeding 100°C a version with VITON® seals is available. Fixing is made in cross holes with 2 lock nuts or in threaded holes with 1 lock nut. The lock nuts allow exact positioning of the cylinder in axial direction.

BLEEDING OF THE SPRING AREA FOR SINGLE-ACTING VERSIONS: If there is a possibility that aggressive cutting lubricants and coolants penetrate through the sintered metal air filter into the cylinder's interior, a vent hose has to be connected and be placed in a protected position, see accessories.

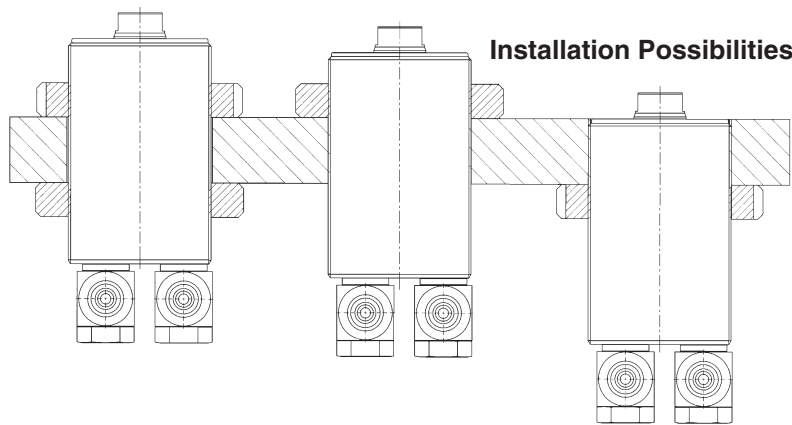

Installation Possibilities

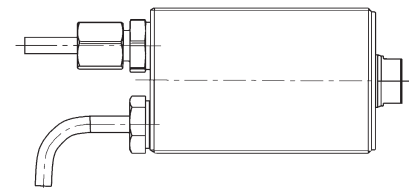

For this purpose the sintered metal air filter has to be exchanged by an insertion nipple fitting, or a corresponding male connector, see accessories.

Application examples

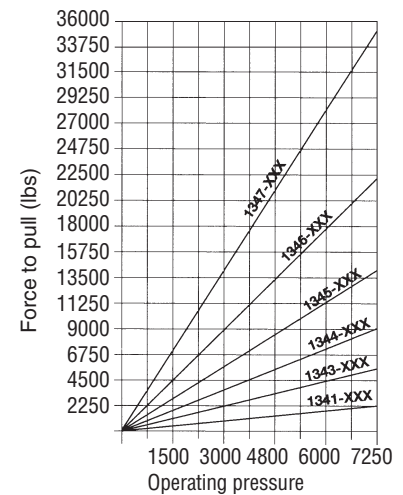
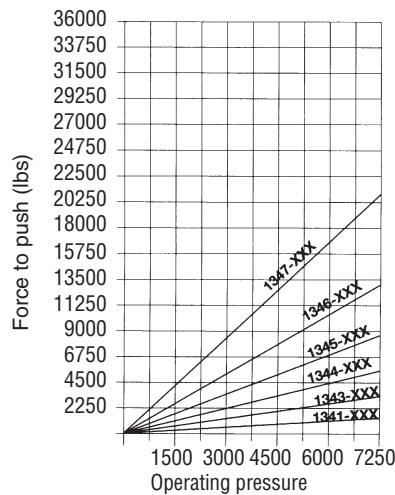
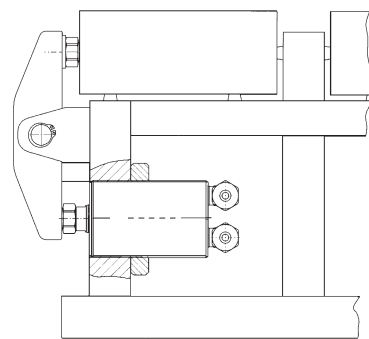
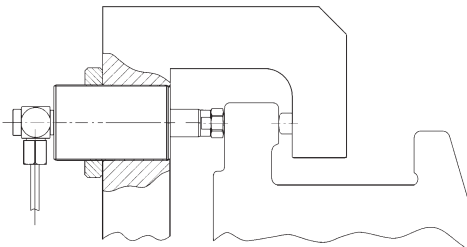

Carr Lane Roemheld Mfg. Co.
Sales — Phone (314) 647-6200 Fax (314) 647-5736
Engineering — Phone 1-800-827-2526 Web roemheld-usa.com

Threaded-Body Universal Cylinder

7250 psi max
Single and double acting

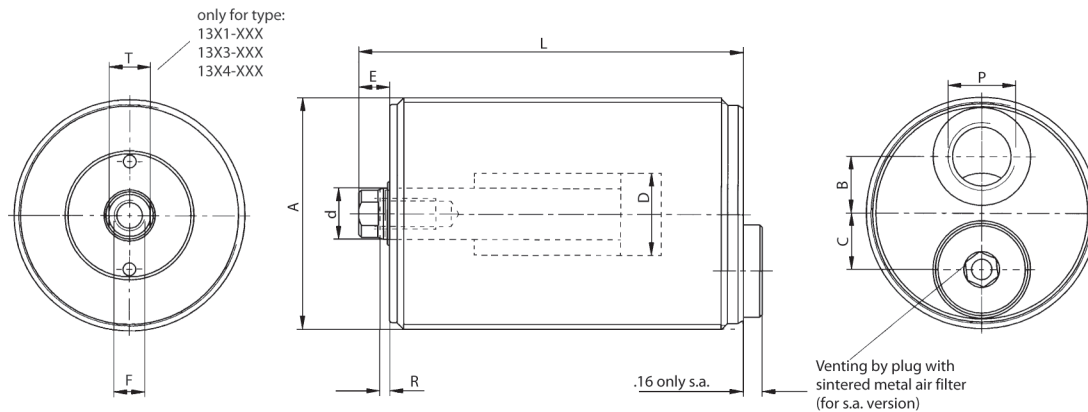

Clamping force (lbs)	7250 psi	2250	5510	9035	14120	22145	35070
	6000 psi	1900	4600	7500	11700	18400	29100
	5000 psi	1600	3800	6200	9700	15300	24200
	4000 psi	1300	3100	5000	7800	12300	19400
	3000 psi	1000	2300	3800	5900	9200	14600
Piston Dia. D		.630	.984	1.260	1.575	1.969	2.480
Rod Dia. D		.394	.630	.787	.984	1.260	1.575
Spring return force, min. (lbs)		11	32	44	61	92	97
Oil Volume in Cubic Inches for each .39 inch of stroke	Stroke to Extend	.12	.3	.5	.8	1.21	2
	Stroke to Retract	.07	.18	.30	.5	.71	1.1
A		M45X1.5	M48x1.5	M55x1.5	M65x1.5	M75x1.5	M90x2
B		.43	.53	.51	.65	.83	1.10
C		.43	.53	.67	.85	1.06	1.32
F		M6X12	M10x15	M12x15	M16x25	M20x30	M27x40
E		.24 (.28)*	.28	.39	.39	.39	.55
P		1/4 BSPP	1/4 BSPP	1/4 BSPP	1/4 BSPP	1/4 BSPP	1/4 BSPP
R		—	—	—	.16	.16	.16
T		8mm	13mm	17mm	—	—	—

Single Acting, with Spring Return

Stroke, short	.31	.31	.39	.39	.47	.47
Total length l	2.95	3.31	3.78	3.90	4.29	4.80
Weight (lbs)	1.5	2	3	4.3	6.3	10
Part No.	CLR-1311-005-TB	CLR-1313-005-TB	CLR-1314-105-TB	CLR-1315-005-TB	CLR-1316-005-TB	CLR-1317-005-TB

Stroke, long	.79	.79	.79	.79	.79	.98
Total length l	4.33	4.49	4.76	4.88	5.28	6.10
Weight (lbs)	2.5	2.8	4	5.6	8	13
Part No.	CLR-1311-025-TB	CLR-1313-025-TB	CLR-1314-125-TB	CLR-1315-025-TB	CLR-1316-025-TB	CLR-1317-035-TB

Double Acting

Stroke, short	.63	.79	.98	.98	.98	1.18
Total length l	2.95	3.31	3.78	3.90	4.29	4.80
Weight (lbs)	1.5	2	3	4	6	9.4
Part No.	CLR-1341-105-TBD	CLR-1343-105-TBD	CLR-1344-105-TBD	CLR-1345-105-TBD	CLR-1346-105-TBD	CLR-1347-105-TB

Stroke, medium	1.97	1.97	1.97	1.97	1.97	2.48
Total length l	4.33	4.49	4.76	4.88	5.28	6.10
Weight (lbs)	2.4	2.7	3.6	5.2	7.5	12
Part No.	CLR-1341-165-TBD	CLR-1343-165-TBD	CLR-1344-165-TBD	CLR-1345-165-TBD	CLR-1346-165-TBD	CLR-1347-175-TBD

Stroke, long	3.94	3.94	3.94	3.94	3.94	3.94
Total length l	6.42	6.46	6.73	6.85	7.24	7.56
Weight (lbs)	3.7	4	5.2	7.4	10.3	14.8
Part No.	CLR-1341-195-TBD	CLR-1343-195-TBD	CLR-1344-195-TBD	CLR-1345-195-TBD	CLR-1346-195-TBD	CLR-1347-195-TBD

Accessories

Part No. lock nut	CLR-3300-326-TBA	CLR-24-HCA	CLR-3300-992-TBA	CLR-3301-661-TBA	CLR-73-HCA	CLR-3300-412-TBA
--------------------------	-------------------------	-------------------	-------------------------	-------------------------	-------------------	-------------------------

* Only for CLR-1311-025-TB and CLR-1341-165-TBD, -195-TBD



Carr Lane Roemheld Mfg. Co.

Sales — Phone (314) 647-6200 Fax (314) 647-5736

Engineering — Phone 1-800-827-2526 Web roemheld-usa.com

Pull Clamps

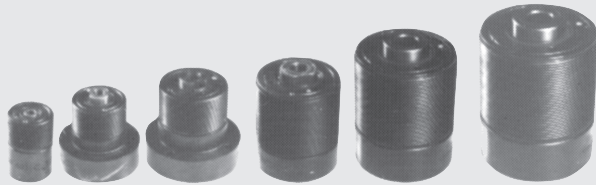

Page 634-635

Hollow-Plunger Clamps

Insert stud through center hole. Quickly converts clamps straps from manual to power operation. Ideal for pulling or pushing a draw bar, and many other applications.

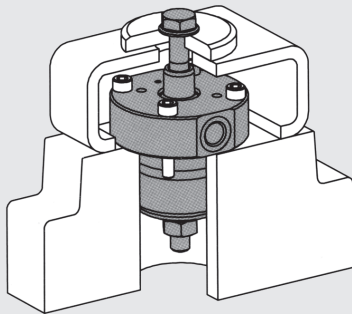

Use in combination with push-pull bolt and "C"-washer to clamp workpieces with center holes.

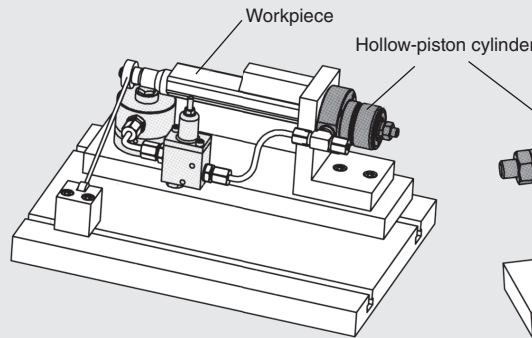

In a machine table, the workpiece can be supported by a work support after clamping with a hollow-piston cylinder in combination with a sequence valve.

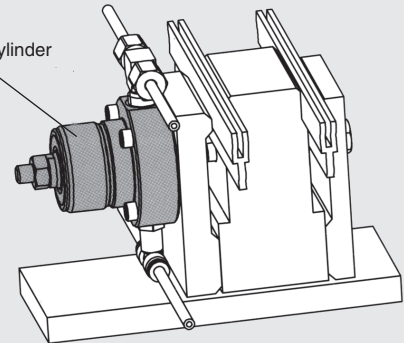

Use for a milling fixture, in conjunction with hollow piston cylinders.



ROEMHELD
HILMA ■ STARK

Carr Lane Roemheld Mfg. Co.
Sales — Phone (314) 647-6200 Fax (314) 647-5736
Engineering — Phone 1-800-827-2526 Web roemheld-usa.com

Hollow-Plunger Clamps

7250 psi max
Single and double acting



- Quickly converts clamp straps from manual to power operation
 - Accepts stud through hollow plunger
 - May be used either to pull or to push
 - Useful for transmitting force to a remote location via a rod
 - Choice of six sizes
- **Do not use NPT fittings**

DESCRIPTION: The piston of this cylinder is provided with a through hole or internal thread. In connection with a standard tie rod and C-washer combination, a variety of applications are possible.

The thread in the piston can be drilled out, if required. If the hollow-piston cylinder is mounted onto movable parts, e.g. clamps, the oil has to be supplied through a high-pressure hose.

CLAMPING ACTION: Fluid pressure pushes up plunger, pulling up a clamping stud inserted through center hole. Spring or fluid return.

CENTER HOLE: Choose either threaded or unthreaded center hole. Threaded version is ideal for pulling/pushing a drawbar or replacing a nut on a clamp strap. Unthreaded version is useful when clamp is removed for workpiece loading.

IMPORTANT NOTES: For operating pressures exceeding 5000 psi, use a grade 8 stud or equivalent.

It is important to torque the lock nut used sufficiently to prevent damaging the piston threads.

Penetration of aggressive cutting lubricants and coolants through the sintered metal air filter into the cylinder's interior should be avoided by appropriate arrangement or covering.

Installation Possibilities

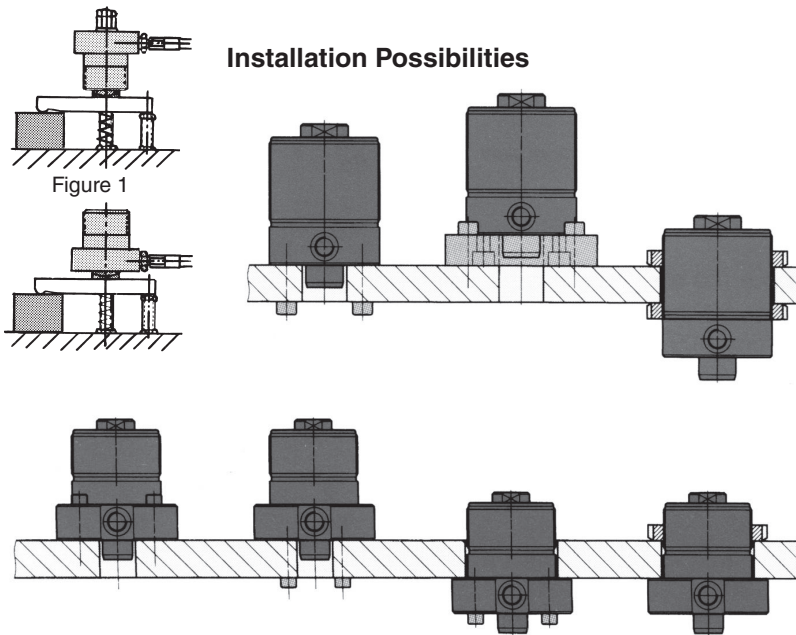

Application Examples

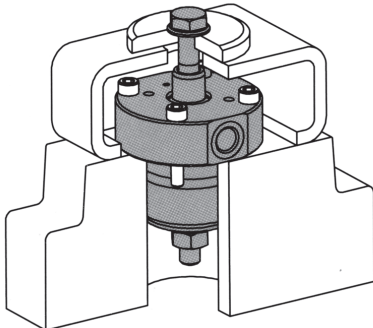

Hollow-piston cylinders in combination with push-pull bolt and "C"-washer can be used efficiently in many cases to clamp workpieces with center holes.

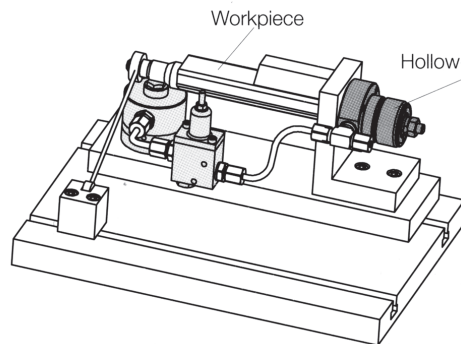

In the shown machine table, the workpiece is supported by means of a work support after clamping with a hollow-piston cylinder in combination with a sequence valve.

The savings in workpiece exchange time, compared to a mechanical clamping system amounts to 58%.

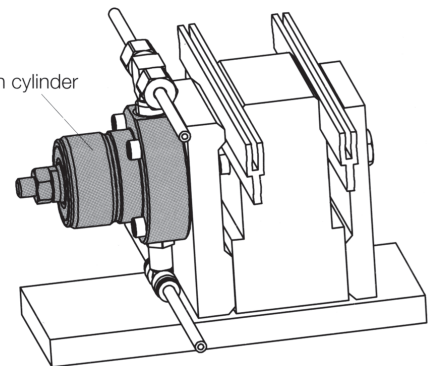

This clamping fixture is for milling operation on a light extruded rail. Workholding by means of hollow-piston cylinders in individual clamping stations mounted on a base plate. Positioning and support of the rail is effected with two longitudinal members matching the cross section of the rail.

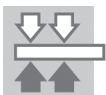

Hollow Plunger Clamps

7250 psi max
Single and double acting

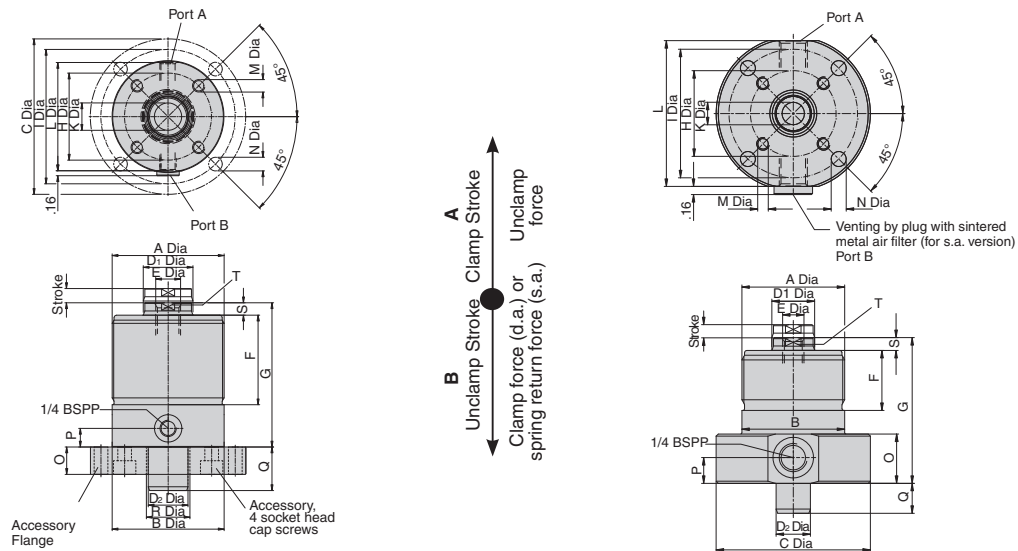

	7250 psi	2250	6745	10565	16545	25990	42375
Clamping Force/ Unclamping Force	6000 psi	1900/1900	5600/4500	8800/7100	13700/10800	21600/17400	35100/28500
	5000 psi	1600/1600	4700/3800	7300/5900	11500/9000	18000/14500	29300/23800
	4000 psi	1300/1300	3800/3000	5900/4800	9200/7200	14400/11600	23400/19000
	3000 psi	1000/1000	2800/2300	4400/3600	6900/5400	10800/8700	17600/14300
	Spring return force (s.a.)	20	45	61	86	106	214
Piston area-clamp (sq.in.)	.3	.93	1.46	2.28	3.56	5.84	
Piston area-unclamp (sq.in.)	.3	.76	1.19	1.80	2.88	4.74	
Oil volume clamp	.25	1.17	2.30	4.50	8.83	18.4	
Oil volume unclamp	.25	.96	1.87	3.54	7.14	15.93	
A Dia	M40x1.5	M48x1.5	M60x1.5	M75x1.5	M90x2	M120x2	
B Dia	1.57	1.89	2.36	2.95	3.54	4.72	
C Dia	2.56	2.83	3.35	4.13	4.92	6.30	
D1 Dia	.472	.787	.984	1.256	1.575	1.969	
D2 Dia	.472	.623	.787	.984	1.256	1.575	
E Dia x depth of thread	M6x8	M10x12	M12x15	M16x20	M20x25	M24x30	
F	1.18	1.10	1.34	2.36	2.83	3.94	
G	2.28	2.68	3.15	3.70	4.57	5.39	
H Dia	1.181	1.575	1.969	2.362	2.756	3.858	
I Dia	2.05	2.36	2.83	3.54	4.25	5.51	
K Dia	.26	.41	.49	.65	.83	.98	
L	2.36	2.68	3.23	2.83	3.43	4.61	
M Dia x depth of thread	M6x8	M6x8	M6x10	M8x10	M10x14	M12x15	
N Dia	.27	.27	.27	.35	.43	.53	
O	.91	.91	.91	.79	.87	.98	
P	.47	.47	.47	.47	.59	.59	
Q	.47	.55	.75	.91	1.38	1.69	
R Dia	—	—	—	1.102	1.378	1.693	
S	.20	.24	.28	.35	.39	.39	
T A/Flats	10mm	17mm	22mm	27mm	36mm	46mm	
Weight (lbs)	1.8	2.6	4	4.9	9.7	2.14	

Single Acting, with Spring Return

Stroke	.24	.31	.39	.47	.63	.79
Part No.	CLR-1752-004-HC	CLR-1754-004-HC	CLR-1755-004-HC	CLR-1756-004-HC	CLR-1757-004-HC	CLR-1758-004-HC

Double Acting

Stroke	.39	.47	.63	.79	1.26	1.57
Part No.	CLR-1752-023-HCD	CLR-1754-023-HCD	CLR-1755-023-HCD	CLR-1756-023-HCD	CLR-1757-023-HCD	CLR-1758-023-HCD

Flange Base

Part No.	—	—	—	CLR-3456-310-HCA	CLR-3456-313-HCA	CLR-3456-312-HCA
Part No., cap screw	—	—	—	CLR-3300-237-HCA	CLR-3300-277-HCA	CLR-3300-054-HCA
Part No., lock ring	CLR-99-HCA	CLR-24-HCA	CLR-11-HCA	CLR-73-HCA	CLR-12-HCA	CLR-34-HCA



ROEMHELD
HILMA ■ STARK

Carr Lane Roemheld Mfg. Co.
Sales — Phone (314) 647-6200 Fax (314) 647-5736
Engineering — Phone 1-800-827-2526 Web roemheld-usa.com

Work Supports

7250 psi max
Single and double acting

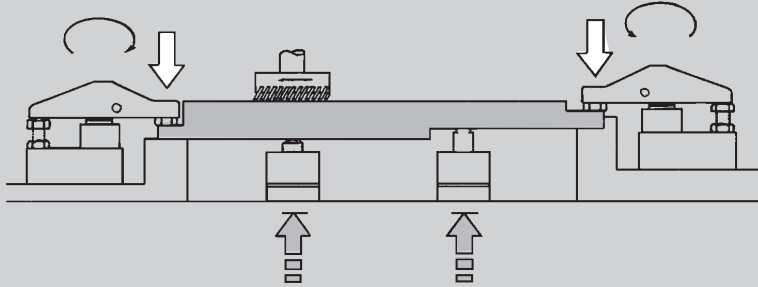

Automatically adjusts to proper height for supporting workpiece. Prevents deflection and vibration due to machining forces. May also be used underneath clamps to back up clamping force. More accurate, more consistent, and much faster than screw jacks.

Precision sleeve around support plunger holds it absolutely vertical while unlocked, then locks it securely when fluid pressure is applied. Plunger remains perfectly stationary during locking. Far better accuracy and repeatability than earlier segmented-collet or sandwiched-plate work supports. Choice of three actions:



Threaded Body
pages 637-641

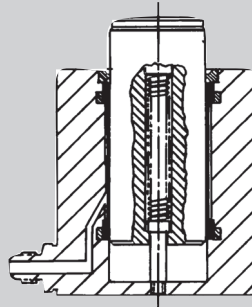

Spring Extended (Plunger floats then locks)

Plunger is normally extended by light spring force. Workpiece's weight depresses plunger to proper height. Applying fluid pressure locks plunger securely.



Threaded Body
pages 637-641

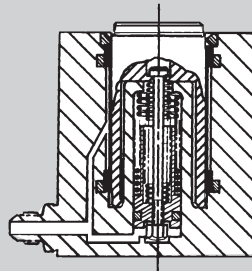

Fluid Advanced (Plunger advances then locks)

Plunger is normally retracted for clear loading/unloading. Applying fluid pressure gently advances plunger to the workpiece, then automatically locks it. Note: do not use advancing plunger to lift loads.

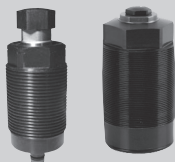

Threaded Body
pages 637-641

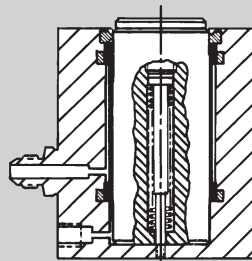

Air Advanced/Extended (Plunger floats or advances by air pressure)

Plunger is normally retracted for clear loading/unloading. Applying air pressure advances plunger to the workpiece. This allows fine tuning contact pressure using a simple air regulator. Contact force may be as light as a few ounces. Applying fluid pressure locks plunger securely.



Threaded-Body Work Supports

7250 psi max
Single Acting



Spring Extended

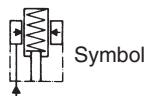

Fluid Advanced

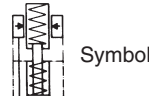

Air Advanced

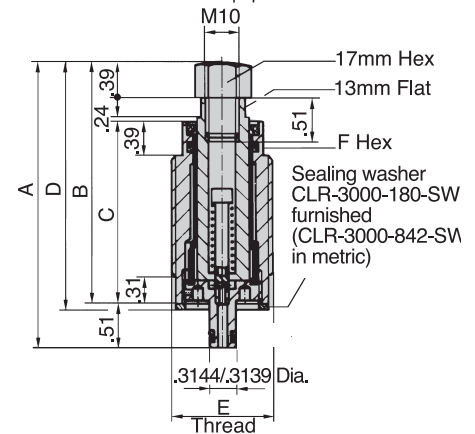
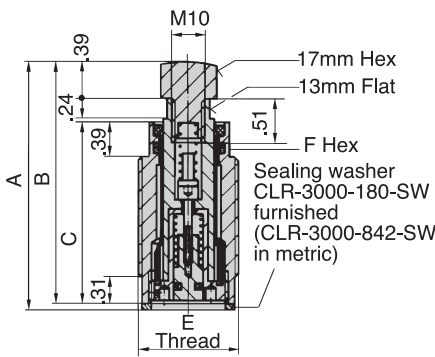
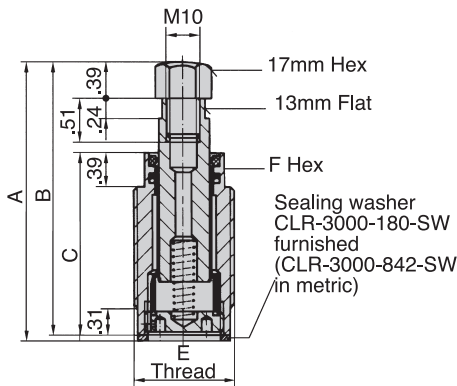
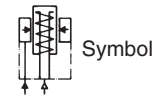

Load Capacity at 7250 psi	1460 Lbs				2135 Lbs				
	Spring Extended	Fluid Advanced	Air Advanced	Spring Extended	Fluid Advanced	Air Advanced	Spring Extended	Fluid Advanced	Air Advanced
Plunger action	Spring Extended	Fluid Advanced	Air Advanced	Spring Extended	Fluid Advanced	Air Advanced	Spring Extended	Fluid Advanced	Air Advanced
Stroke	.31	.31	.59	.31	.31	.59	.31	.31	.59
Max. load capacity (lbs)	1460	1460	1460	1460	2135	2135	1460	2135	2135
Fluid required (cu.in)	.01	.10	.10	.01	.10	.18	.01	.10	.01
Max. fluid flow rate (cu.in./min.)	—	100	100	—	100	100	—	100	—
Contact force, min/max (lbs)	1.8 to 3.0	2.2 to 5.2	2.2 to 5.2	See text	1.8 to 3.0	2.2 to 5.2	2.2 to 5.2	See text	See text
Max. operating pressure (psi)	7250	7250	7250	7250	7250	7250	7250	7250	7250
Min. operating pressure (psi)	1460	1460	1460	1460	1460	1460	1460	1460	1460
A	3.17	2.85	3.13	3.31	3.56	3.25	3.52	3.70	3.70
B	3.11	2.80	3.07	2.80	3.50	3.19	3.46	3.19	3.19
C	2.13	2.13	2.40	2.13	2.52	2.52	2.80	2.52	2.52
D	—	—	—	2.85	—	—	—	—	3.25
Weight (lbs)	.6	.6	.6	.6	.6	.6	.6	.6	.6

Inch

	1-1/4-16	1-1/4-16	—	1-1/4-16	—	—	—	—
E Thread	1-1/4-16	1-1/4-16	—	1-1/4-16	—	—	—	—
F Hex	1.06	1.06	—	1.06	—	—	—	—
Part No., Work Support only	CLR-001-WS	CLR-201-WS	—	CLR-101-WS	—	—	—	—
Part No., Base only	CLR-712-WSA	CLR-712-WSA	—	CLR-711-WSA	—	—	—	—
Part No., Work Support with Base	CLR-000-WS	CLR-200-WS	—	CLR-100-WS	—	—	—	—

Metric

	M30x1.5	M30x1.5	M30x1.5	M30x1.5	M30x1.5	M30x1.5	M30x1.5	M30x1.5
E Thread	M30x1.5	M30x1.5	M30x1.5	M30x1.5	M30x1.5	M30x1.5	M30x1.5	M30x1.5
F Hex	24mm	24mm	24mm	24mm	24mm	24mm	24mm	24mm
Part No., Work Support only	CLR-1940-000-WS	CLR-1942-000-WS	CLR-1942-005-WS	CLR-1941-000-WS	CLR-1940-010-WS	CLR-1942-010-WS	CLR-1942-015-WS	CLR-1941-010-WS



ROEMHELD
HILMA ■ STARK

Carr Lane Roemheld Mfg. Co.
Sales — Phone (314) 647-6200 Fax (314) 647-5736
Engineering — Phone 1-800-827-2526 Web roemheld-usa.com

Threaded-Body Work Supports

7250 psi max
Single acting

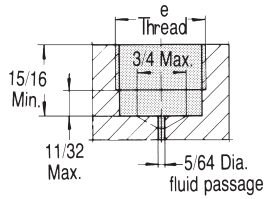

**Hole Preparation
(Spring Extended and
Fluid Advanced)**

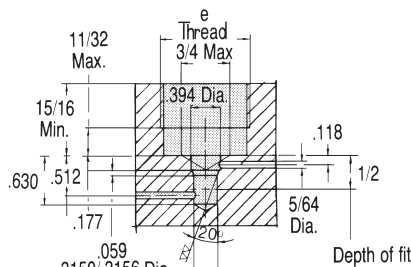

Hole Preparation (Air Advanced)

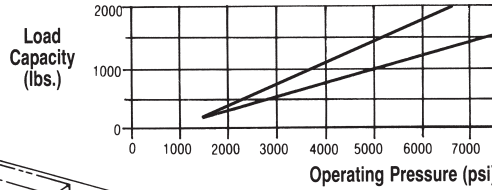
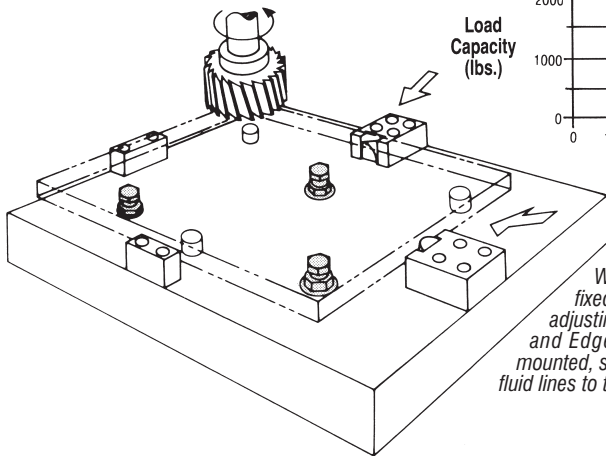

*Example:
Workpiece supported by three
fixed rest buttons and three
self-adjusting Work Supports. Supports
and Edge Clamps are all manifold
mounted, so the fixture has no exposed
fluid lines to trap chips.*

OPTIONAL BASE

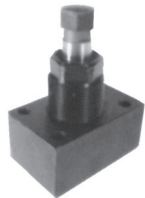

**Spring-Extended
Work Support
with Base
CLR-000-WS**

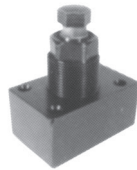

**Fluid-Advanced
Work Support
with Base
CLR-200-WS**

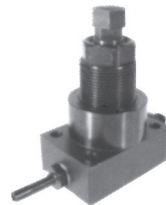

**Air-Advanced
Work Support
with Base
CLR-100-WS**

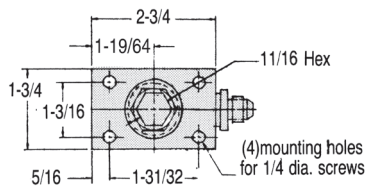

**Base Only
CLR-712-WSA**

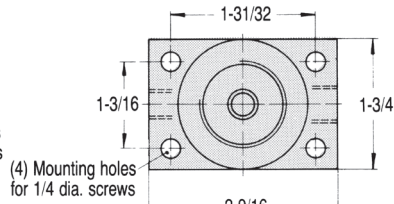

**Base Only
CLR-711-WSA**

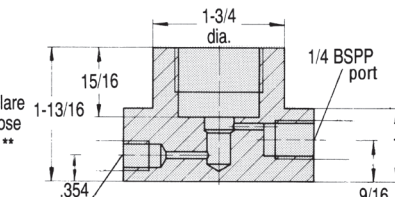
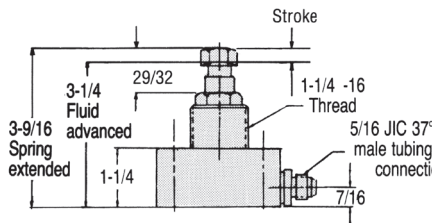

- Amazingly compact threaded body work support, only 1-1/4 inches in diameter!
- Height adjusts automatically with repeatability with $\pm .0002$ inches
- Choice of two sizes in each of three-action types, plus a long-stroke fluid-advanced model (1700 lbs)
- Support plunger held by an advanced design, sliding-fit pressure sleeve (holds plunger absolutely vertical, locked or unlocked)

SUPPORT ACTION (SPRING EXTENDED): Plunger is normally extended by light spring force. Workpiece's weight depresses plunger to proper height. When fluid pressure is applied, precision sleeve grips plunger, locking it securely.

SUPPORT ACTION (FLUID ADVANCED): Plunger is normally retracted for clear workpiece loading/unloading. Applying fluid pressure gently advances plunger to workpiece, where it contacts with light spring force. When fluid pressure is applied, precision sleeve grips plunger, locking it securely. Plunger retracts again when pressure is released.

SUPPORT ACTION (AIR ADVANCED): Plunger is normally retracted for clear workpiece loading/unloading. Applying air pressure gently advances plunger to workpiece. A simple 3-way air valve, fine pressure regulator, and air dryer are required. Fine tune contact pressure using regulator. When fluid pressure is applied, precision sleeve grips plunger, locking it securely. Plunger retracts again when air pressure is released. Air-advanced version is also available without spring return for extremely sensitive contact-force adjustment (part no. CLR-7990-284-WS without base, CLR-110-WS with base).

ACCURACY: Height repeatability $\pm .0002$ inches. Excellent repeatability because (1) sliding fit sleeve keeps plunger absolutely vertical while unlocked, avoiding inaccuracy due to locking a tilted plunger, and (2) locking force is entirely radial, so plunger stays absolutely stationary during locking. Elastic deflection of plunger is only $.00016$ inches per 100 lbs. machining load.

MOUNTING: Screw work support into a tapped hole prepared as shown below. Hole bottom must be perpendicular to the hole's axis, with a 125 RMS maximum surface finish. Minimum seating torque 50 ft.-lbs. Supply fluid through passages drilled in the fixture.

SEQUENCING: If workpiece is too light to depress plunger (spring extended) or light enough that plunger contact may lift it (fluid advanced), a sequence valve is recommended. Sequence valve delays locking or advancing the plunger until after the workplace is clamped.

CONSTRUCTION: Steel plunger, hardened and ground. Plunger held inside a honed locking sleeve (sliding fit). Carbon steel body, black oxide finish. Hardened contact bolt furnished.



Carr Lane Roemheld Mfg. Co.

Sales — Phone (314) 647-6200 Fax (314) 647-5736

Engineering — Phone 1-800-827-2526 Web roemheld-usa.com

Work Supports ■ R-Series ■ B1.9405

Thr. Body Work Support ■ M26 size ■ 3 types of function - Hydraulic, Air, Spring Single Acting ■ Max. Operating Pressure ■ 5075 psi (350 bar)

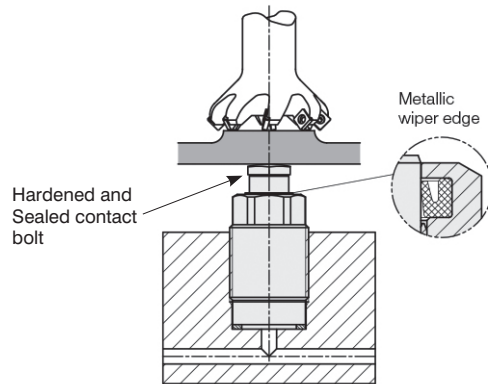
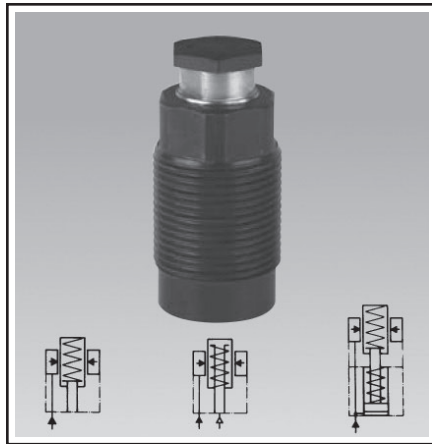

Work Supports are used to provide a self-adjusting rest of workpieces to minimize vibration and deflection from machining forces. This family is one very compact size (M26) with three actuation types (Spring, Air, or Oil extended). They are designed with an integrated metallic wiper edge backed up by an FKM wiper to provide excellent resistance to chips and fluid. All internal components are made of highly corrosion resistant materials. Ventless design.

Spring Extended

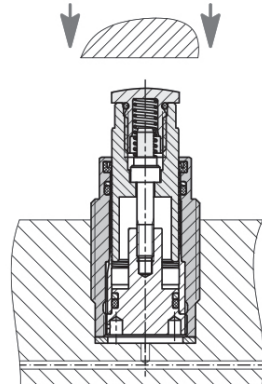

Part No. CLR-1940-900 Stroke .256

Air Advanced

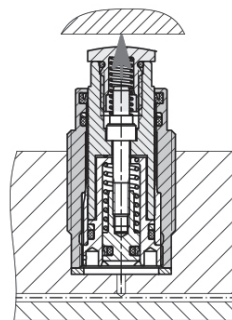

Part No. CLR-1941-900 Stroke .256

Oil Advanced

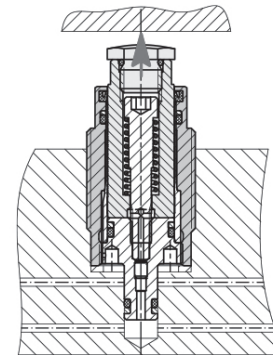

**Part No. CLR-1942-900 Stroke .256
Part No. CLR-1942-925 Stroke .59**

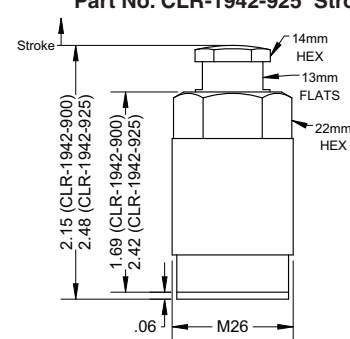
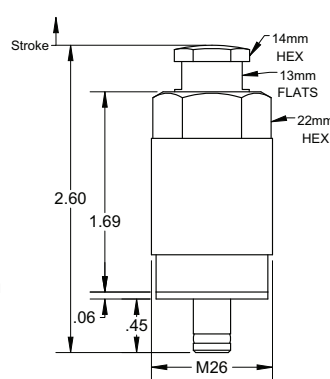
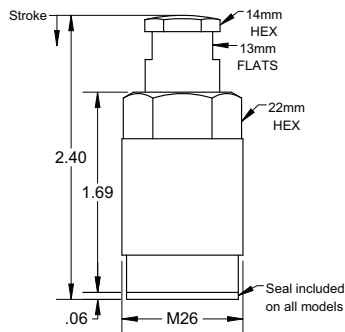

Load Support Capacity at 5075 psi (lbs)	900
Support plunger Ø (in)	0.63
Max. Flow Rate (in ³ /min)	91.5
Recommended Min. Pressure (psi)	1450
Contact force (lbs) at 14.5 psi air pressure (CLR-1941-900, deduct spring force)	4.5
Contact Spring Force Min./Max. (lbs) For CLR-1942-925 this only applies to the last .256 inch of the total .59 inch stroke	3.4/5.6

See data sheet B1.9405 for full technical details.

Accessories

Flow Control Orifice Disc for CLR-1942-900 & CLR-1942-925	CLR-3420-395
---	--------------



ROEMHELD
HILMA ■ STARK

Carr Lane Roemheld Mfg. Co.
Sales — Phone (314) 647-6200 Fax (314) 647-5736
Engineering — Phone 1-800-827-2526 Web roemheld-usa.com

Work Supports ■ R-Series ■ B1.943

Thr. Body Work Support ■ 4 sizes ■ 3 types of function - Hydraulic, Air, Spring Single Acting ■ Max. Operating Pressure ■ 7250 psi (500 bar)

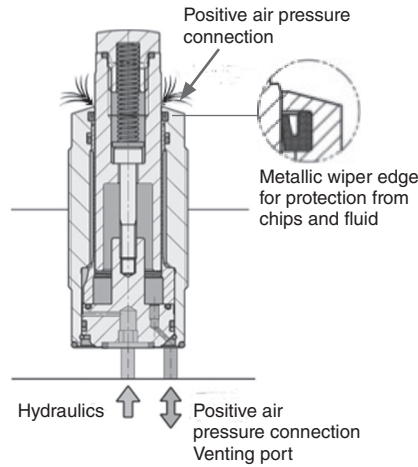
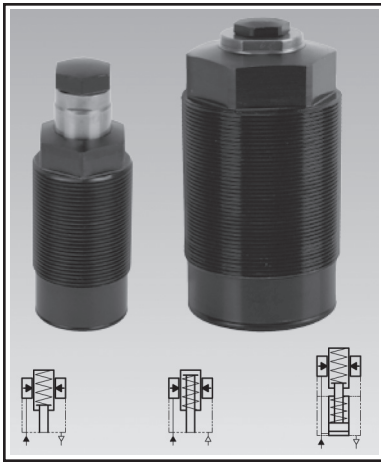

Work Supports are used to provide a self-adjusting rest of workpieces to minimize vibration and deflection from machining forces. This family of products provides multiple mounting options and four sizes within each of the three actuation types (Spring, Air, or Oil extended). They are designed with an integrated metallic wiper edge backed up by a FKM wiper to provide excellent resistance to chips and fluid. All internal components are made of highly corrosion resistant materials. If additional protection is required, the work supports can be piped to have a low-pressure air blow-off from the wiper area.

Installation and connecting possibilities

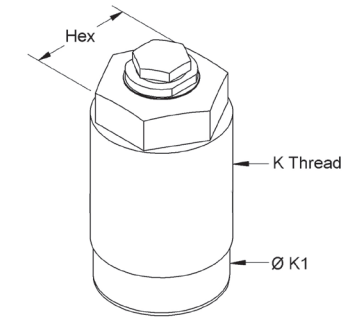

Drilled channels

O-Ring connection

Tube connection

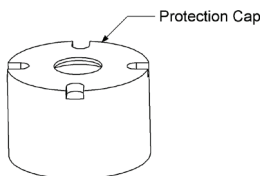
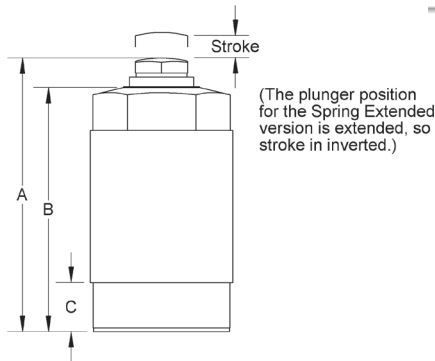
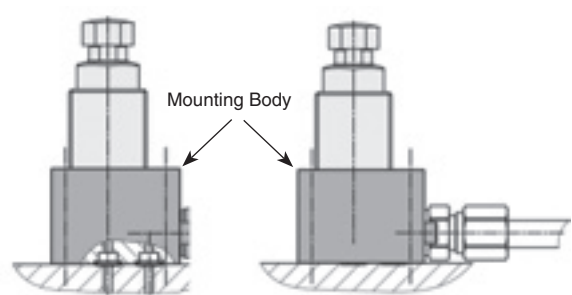
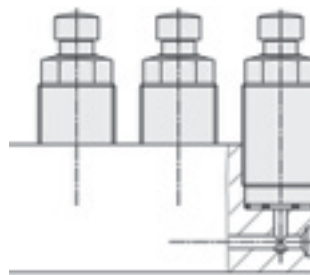

The Protection Cap can be installed between the contact bolt and plunger to protect the wiper area from high pressure coolant and chips.

Load Capacity at 7250 psi (lbs)	1460	3372	5283	9440
Stroke (in.)	0.31	0.39	0.39	0.63
A (in.)	2.97	3.39	3.54	4.53
B (in.)	2.32	2.85	3.07	4.04
C (in.)	0.33	0.69	0.81	0.81
K Thread	M30 x 1.5	M36 x 1.5	M48 x 1.5	M60 x 1.5
Ø K1 (in.)	1.12	1.35	1.83	2.3
Hex (in.)	0.94	1.18	1.61	1.97
Weight (lbs)	0.66	1.1	1.98	4.19
Part No., Spring Extended	CLR-1940-300	CLR-1940-400	CLR-1940-501	CLR-1940-601
Part No., Air Advanced	CLR-1941-300	CLR-1941-400	CLR-1941-501	CLR-1941-601
Part No., Fluid Advanced	CLR-1942-300	CLR-1942-400	CLR-1942-501	CLR-1942-601

Accessories

Part No., Mounting Body	CLR-0346-815	CLR-0346-816	CLR-0346-817	CLR-0346-818
Part No., Protection Cap (splash guard)	CLR-3546-110	CLR-3546-111	CLR-3546-112	CLR-3546-113

Subject to change. For further details, including detailed dimensions and mounting instructions, visit roemheld-usa.com.



ROEMHELD
HILMA ■ STARK

Carr Lane Roemheld Mfg. Co.

Sales — Phone (314) 647-6200 Fax (314) 647-5736

Engineering — Phone 1-800-827-2526 Web roemheld-usa.com

Work Supports ■ Threaded-Body Work Support ■ B1.944

Threaded-Body Work Support ■ with metal wiper ■ optional contact control Double Acting ■ Max. Operating Pressure ■ 7250 psi (500 bar)



Hydraulic work supports are used to provide a self-adjusting rest for workpieces and avoid vibration and deflection under machining loads. The threaded-body design allows for space saving by direct installation into the fixture body. Double-acting allows for a defined time on the return stroke of the support plunger for cycle-dependent applications. Metallic wiper edge and FKM wiper come standard. To guarantee

performance a vent port is imperative; by connecting a slight pneumatic pressure to the venting system the work support is effectively protected against the penetration of liquids. If a strong coolant jet is directed onto the support plunger or wiper edge an optional protective cap is available. Also optional is pneumatic workpiece contact control, allowing recognition of when work support has contacted the workpiece.

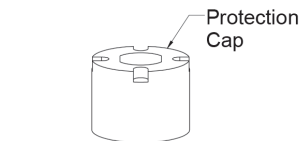
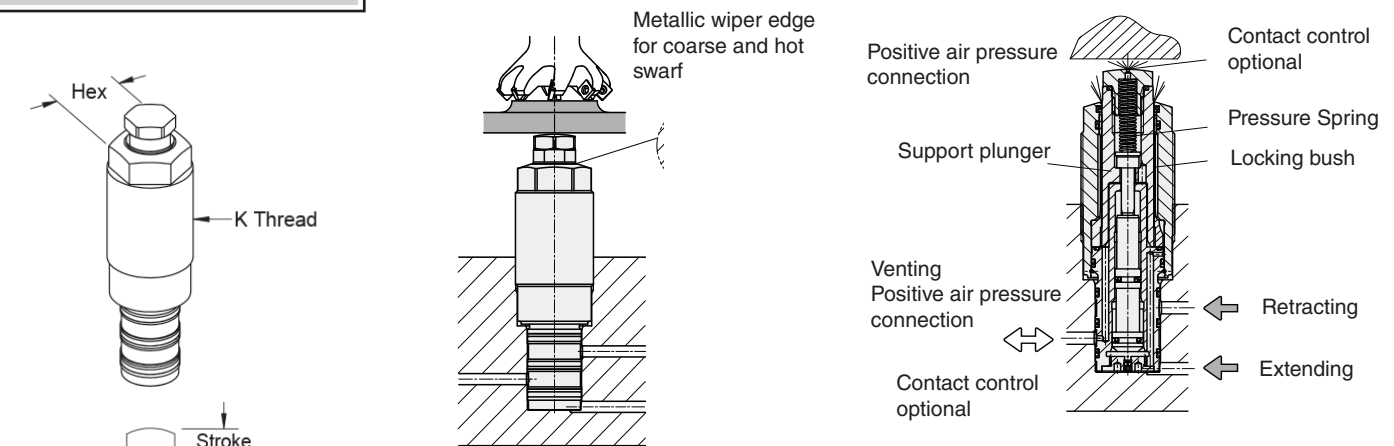

The Protection Cap can be installed between the contact bolt and plunger to protect the wiper area from high pressure coolant and chips.

Load capacity at 7250 psi (lbs)	1460	3370	5285	9440
Stroke (in.)	0.31	0.39	0.39	0.63
A (in.)	4.51	4.90	5.18	6.22
B (in.)	2.96	3.37	3.53	4.51
C (in.)	0.31	0.67	0.79	0.79
K Thread	M30 x 1.5	M36 x 1.5	M48 x 1.5	M60 x 1.5
Ø F (in.)	0.87	0.98	1.18	1.38
Hex (in.)	0.94	1.18	1.61	1.97
Weight (lbs)	1.04	1.50	2.71	5.4
Part No.	CLR-1942-310	CLR-1942-410	CLR-1942-510	CLR-1942-610
Part No., with contact control	CLR-1942-310P	CLR-1942-410P	CLR-1942-510P	CLR-1942-610P
Contact bolt for contact control	CLR-3614-390	CLR-3614-389	CLR-3614-391	CLR-3614-418

Accessories				
Weight (lbs)	0.05	0.05	0.07	0.14
Protection Cap (splash guard)	CLR-3546-110	CLR-3546-111	CLR-3546-112	CLR-3546-113

Subject to change. For further details, including detailed dimensions and mounting instructions, visit roemheld-usa.com.



ROEMHELD
HILMA ■ STARK

Carr Lane Roemheld Mfg. Co.
Sales — Phone (314) 647-6200 Fax (314) 647-5736
Engineering — Phone 1-800-827-2526 Web roemheld-usa.com

Power Vises and Concentric Clamping

Power Machine Vises

Carr Lane Roemheld has a wide variety of machine vises for your applications, made of the finest quality construction for excellent rigidity and durability. More varieties can be found in the Machining Vises section at clrh.com.

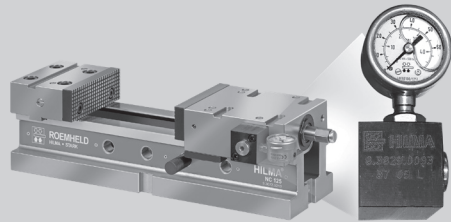

NC-Series Machining Center Vises
pages 644-645

Machining Center Vises — NC-series Vises, available with or without gauge, are available in both hydraulic and hydromechanical versions. The hydraulic version provides automatic power clamping with exact high force at the push of a button. The hydromechanical version is manually operated, with final high force applied easily using hydraulic power assist.

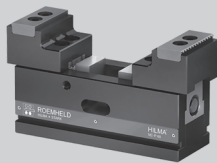

MC-P Fixed Jaw Vises
page 651

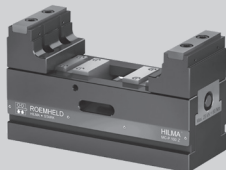

MC-P Z Concentric Vises
page 652

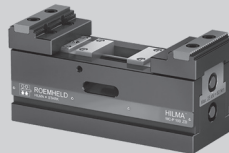

MC-P ZB Position Flexible Vises
page 653

MC-P Vises are especially advantageous for 5-axis machining. Compact design allows for collision-free tool paths and access to all 5 sides with short standard tools. The patented three-piece segment design allows for a high degree of precision. Due to the predesigned swarf protection, they are particularly suitable for use in pallet systems.

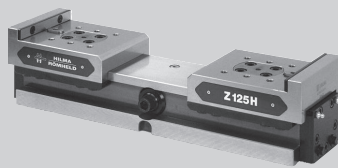

Concentric Vises
pages 656-657

Concentric Vises offer quick, accurate clamping of odd-sized workpieces. These vises may be used in machining centers, on machine tools and final processing machines as well as in special jigs and fixtures. These self-centering vises position and clamp workpieces precisely on a defined symmetrical axis, allowing for any contours, and have a high clamping repeatability of $\pm 0.01\text{mm}$.

Vise Jaws and Accessories
pages 660-661, 666-669



Power Vises and Fixturing Systems

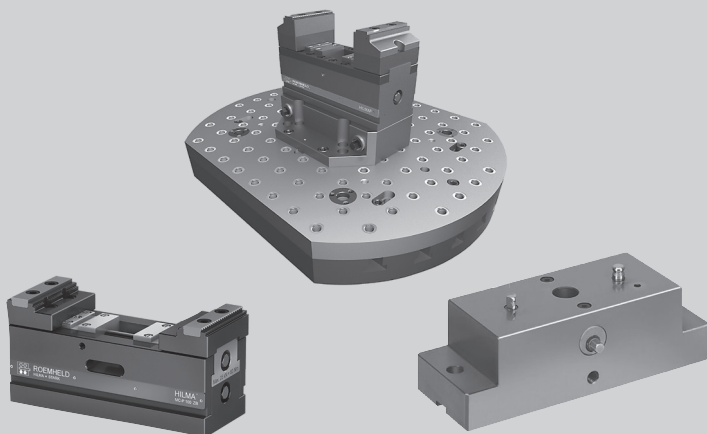

**CL5® Quick-Change
Five-Axis Workholding**

page 649



**Quick-Change
Five-Axis Workholding**

Accurate and versatile fixture for round, square, and hex-shaped workpieces. Mounts vertically or horizontally, and uses standard 5C collets. Advanced workpiece-release mechanism for flawless operation. Far better accuracy and repeatability than competitive collet vises. Workpiece is pulled solidly against the bottom stop for excellent height repeatability.

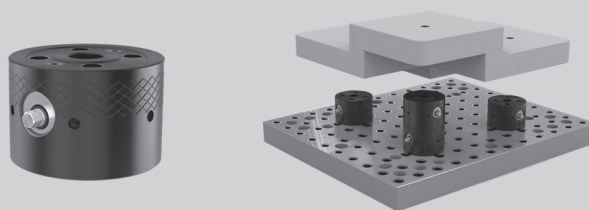

**DropZero
Modular Zero Point System**

pages 658-661



Modular Zero Point System

New DropZero Modular Zero-Point Clamping System enables complete machining of a workpiece in one setup, significantly reducing setup time and fixturing costs. With a few turns of a wrench, DropZero locates, supports, and securely clamps the workpiece from underneath, providing full machining access to 5 sides. Drop Zero can be used with modular or non-modular tooling.



With Fixed Jaw
page 662

Concentric
page 663

Position Flexible
page 664

Fixture Clamps

Fixture clamps consist of a very compact body with integrated hydraulic cylinders that actuate the movable jaw. All threads and ports are at the bottom which allows for a very tight and space savings arrangement. Accessory blank jaws are also available that can be milled to match the workpiece contour.



ROEMHELD
HILMA ■ STARK

Carr Lane Roemheld Mfg. Co.
Sales — Phone (314) 647-6200 Fax (314) 647-5736
Engineering — Phone 1-800-827-2526 Web roemheld-usa.com

Machining-Center Vises ■ NC Series

5075 psi max
Single acting

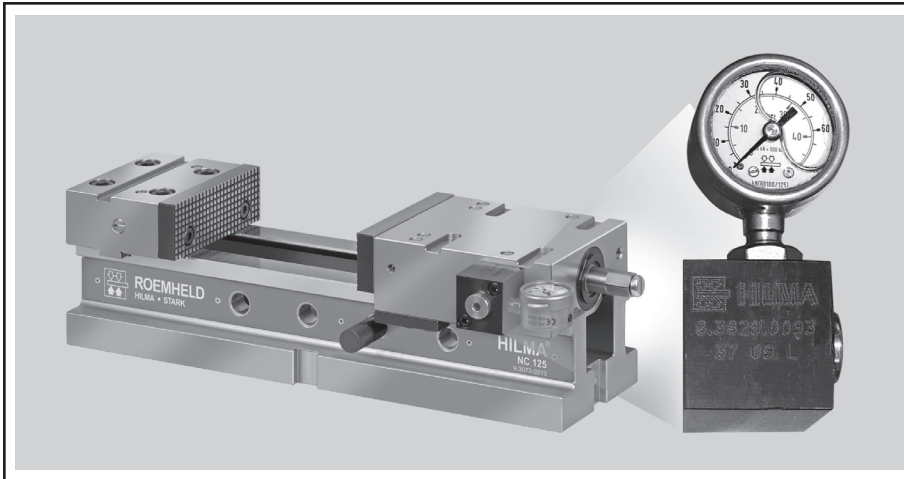

**NC Series Hydra-Mechanical
(shown with gauge)**

- Hydraulic version provides automatic power clamping with exact high force at the push of a button (requires external power unit)
- Hydra-mechanical version is manually operated, with final high force applied easily using hydraulic power assist
- Finest-quality construction for excellent rigidity and durability
- Choice of three sizes

OPERATION OF HYDRAULIC VERSION: To set up initially, adjust jaw opening to the workpiece using the removable crank handle. When fluid pressure is applied by actuating the external power unit, the sliding jaw moves through its power stroke to apply full clamping force (.276" maximum stroke for safety). Unclamping is by positive spring return.

OPERATION OF HYDRA-MECHANICAL VERSION: Turning the crank handle clockwise moves the sliding jaw mechanically toward the workpiece. Once resistance is met, further turning automatically disengages the screw spindle and gradually applies full hydraulic pressure, with relatively little effort. Turn handle counterclockwise to unclamp.

MOUNTING: Vises are all slotted underneath for 20mm fixture keys, to provide accurate mounting on T-slotted machine tables. Use two Step Fixture Keys to adapt to a specific table-slot size (see tooling-component catalog section). A hardened steel pin fits into any of the adjustment holes on each side of the guide rails, to provide quick coarse adjustment of jaw opening.

ACCESSORIES: A crank handle is furnished with each vise. Optional right-angle-drive units (hydra-mechanical version only) are highly recommended if vises are mounted vertically.

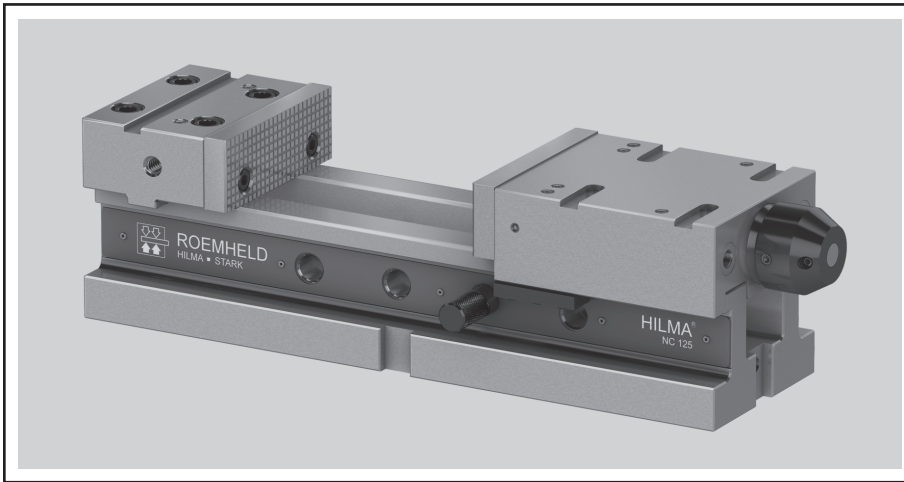

NC Series Hydraulic

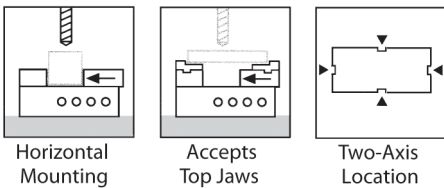

Horizontal Mounting

Accepts Top Jaws

Two-Axis Location

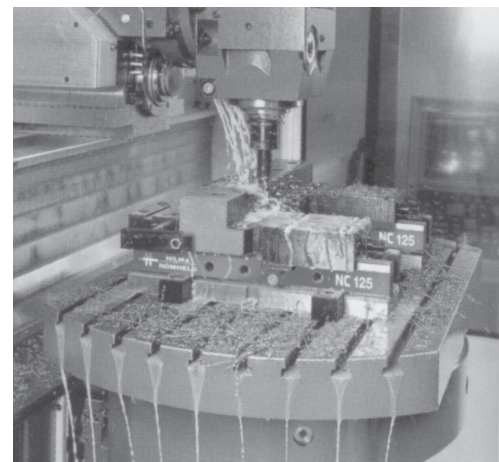

NC-Series vises are ideal for precision, high-production machining on all types of vertical machining centers.



Carr Lane Roemheld Mfg. Co.
Sales — Phone (314) 647-6200 Fax (314) 647-5736
Engineering — Phone 1-800-827-2526 Web roemheld-usa.com

Machining-Center Vises NC Series

5075 psi max
Single acting

Hydraulic

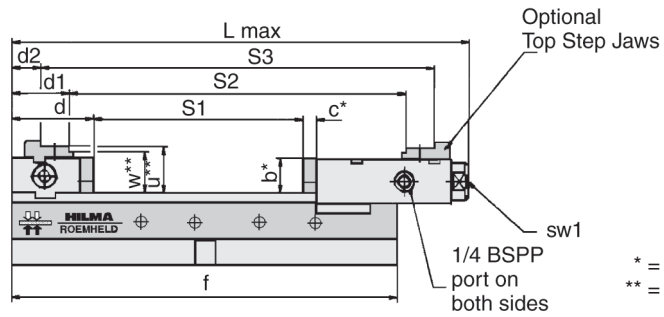
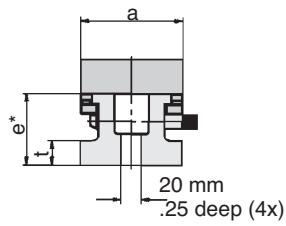

* = Tolerance ± .0004
** = Tolerance ± .0008

Hydra-Mechanical

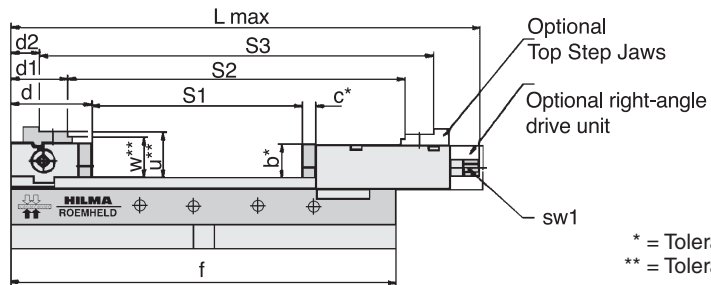
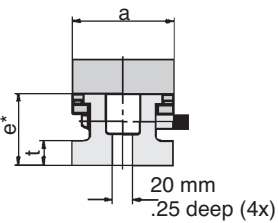

* = Tolerance ± .0004
** = Tolerance ± .0008



Force Limiting Adapter	
100mm	CLRH-9-3762-0100-VSA
125mm	CLRH-9-3762-0125-VSA
160mm	CLRH-9-3762-0160-VSA

Jaw Width	100mm	125mm	160mm
a	3.937	4.921	6.299
b	1.3386	1.7717	2.1260
c	.5118	.5906	.7087
d	3.1496	3.9370	4.7244
d1	2.2047	2.7165	2.8346
d2	1.1024	1.3780	1.4567
e	2.7559	3.2283	3.7402
f	14.96	16.93	21.65
t	.94	1.06	1.06
u	1.7717	2.2835	2.7559
w	1.5748	2.0866	2.5591
Weight (lbs)	41	69	129



Optional Right-Angle Drive Unit for Hydra-Mechanical Version

Hydraulic Vises			
Max. clamping force (lbs)	5620	8990	14160
Power stroke	.197	.197	.276
Max. operating pressure (psi)	5000	5000	5000
Fluid required (cu.in.)	.31	.43	.85
L max	17.95	20.39	26.57
S1	8.23	8.98	12.36
S2	13.15	14.41	20
S3	15.35	17.09	22.76
sw1	8mm	8mm	10mm
Part No., Vise	CLRH-9-3082-0203	CLRH-9-3083-0203	CLRH-9-3084-0203

Hydra-Mechanical Vises			
Max. clamping force (lbs)	5620	8990	11240
Max. cranking force required (lbs)	11	17	21
crank throw	3.15	3.94	4.92
L max	18.27	20.71	26.93
S1	8.07	8.86	12.17
S2	12.99	14.29	19.80
S3	15.20	16.97	22.56
sw1	14mm	17mm	19mm
Part No., Vise	CLRH-9-3072-0203	CLRH-9-3073-0203	CLRH-9-3074-0203
Part No., Right-Angle Drive Unit	CLRH-9-3294-0505	CLRH-9-3294-0605	CLRH-9-3294-0705
Part No., Vise with Gauge	CLRH-9-3072-0215	CLRH-9-3073-0215	CLRH-9-3074-0215



ROEMHELD
HILMA ■ STARK

Carr Lane Roemheld Mfg. Co.
Sales — Phone (314) 647-6200 Fax (314) 647-5736
Engineering — Phone 1-800-827-2526 Web roemheld-usa.com

Vise Jaws

Machine Vise Jaws

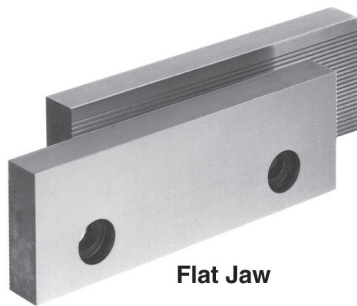

Flat Jaw

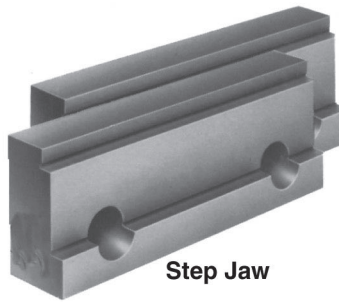

Step Jaw

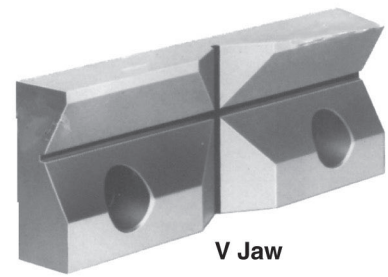

V Jaw

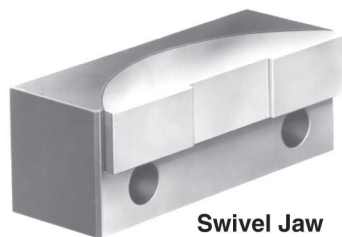

Swivel Jaw

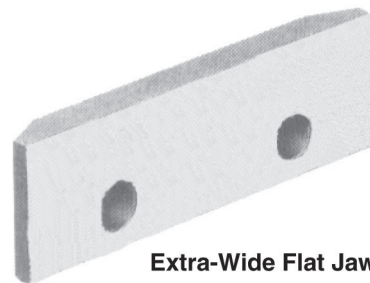

Extra-Wide Flat Jaw

Jaw Type (Single Jaw)	100mm Vise	125mm Vise	160mm Vise
Part No., Standard Flat Jaw	CLRH-5-2058-1003-VSA	CLRH-5-2058-1004-VSA	CLRH-5-2058-1005-VSA
Part No., Soft Flat Jaw	CLRH-5-2055-0097-VSA	CLRH-5-2055-0098-VSA	CLRH-5-2055-0099-VSA
Part No., Extra Wide Flat Jaw	CLRH-5-2058-1025-VSA	CLRH-5-2058-1026-VSA	CLRH-5-2058-1027-VSA
Part No., V Jaw	CLRH-5-3030-0002-VSA	CLRH-5-3030-0003-VSA	CLRH-5-3030-0004-VSA
Part No., Swivel Jaw	CLRH-3711-02-VSA	CLRH-3711-03-VSA	CLRH-3711-04-VSA
Part No., Step Jaw	CLRH-5-2082-0001-VSA	CLRH-5-2082-0002-VSA	CLRH-5-2082-0003-VSA

Quick-Insert – System Jaws

Base jaws are screwed to the fixed jaw and to the slide. Inserts, kept in place by two permanent magnets, can be changed in a few seconds.

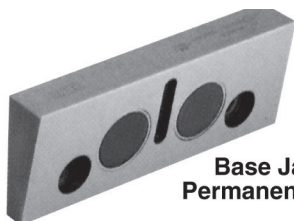

Base Jaw with Permanent Magnets



Standard Jaw Insert

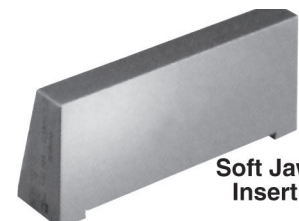

Soft Jaw Insert

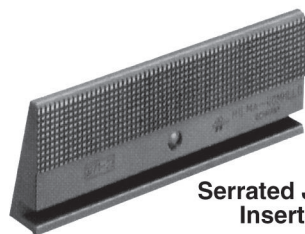

Serrated Jaw Insert



Step Jaw Insert

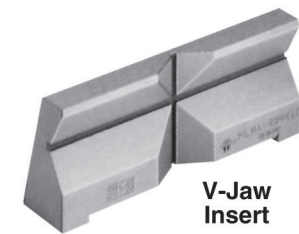

V-Jaw Insert

Jaw Type (Single Jaw)	100mm Vise	125mm Vise	160mm Vise
Part No., Magnetic Base Jaw	CLRH-3771-02-VSA	CLRH-3771-03-VSA	CLRH-3771-04-VSA
Part No., Standard Jaw Insert	CLRH-3771-12-VSA	CLRH-3771-13-VSA	CLRH-3771-14-VSA
Part No., Soft Jaw Insert	CLRH-3771-72-VSA	CLRH-3771-73-VSA	CLRH-3771-74-VSA
Part No., Serrated Jaw Insert	CLRH-3771-22-VSA	CLRH-3771-23-VSA	CLRH-3771-24-VSA
Part No., Step Jaw Insert	CLRH-3771-42-VSA	CLRH-3771-43-VSA	CLRH-3771-44-VSA
Part No., V Jaw Insert	CLRH-3771-52-VSA	CLRH-3771-53-VSA	CLRH-3771-54-VSA



ROEMHELD
HILMA ■ STARK

Carr Lane Roemheld Mfg. Co.

Sales — Phone (314) 647-6200 Fax (314) 647-5736

Engineering — Phone 1-800-827-2526 Web roemheld-usa.com

Vise Accessories

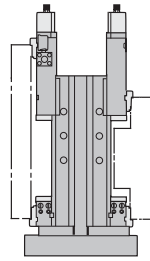
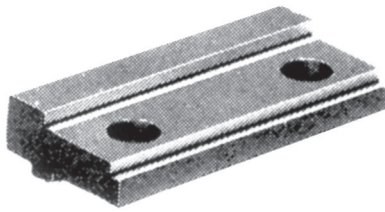

Precision step jaws that mount on top of the fixed and sliding jaws, extending jaw capacity significantly. These hardened and ground jaws are keyed to maintain excellent positional accuracy, as well as height accuracy. Note: top step jaws for sliding jaws have a wider hole spacing than those for fixed jaws. Two mounting screws are included.

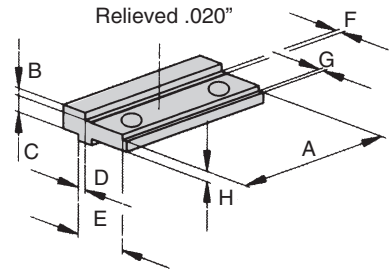

Top Step Jaws

Part No. for Fixed Jaw	Part No. for Sliding Jaw	Jaw Width	A	B	C ±.0004	D ±.0004	E ±.0004	F	G	H ±.0004
CLRH-3284-02-VSA	CLRH-3284-12-VSA	100mm	3.9370		.4528	.2362	1.3386			.2559
CLRH-3284-03-VSA	CLRH-3284-13-VSA	125mm	4.9213	.197	.5512		1.5748	.197	.157	.3543
CLRH-3284-04-VSA	CLRH-3284-14-VSA	160mm	6.2992		.6693	.3150	1.6929			.4724

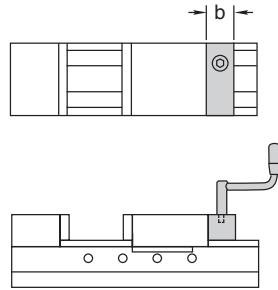

Extremely useful accessory for hydra-mechanical vises. Recommended when cranking from the end is difficult, especially when vises are mounted vertically.

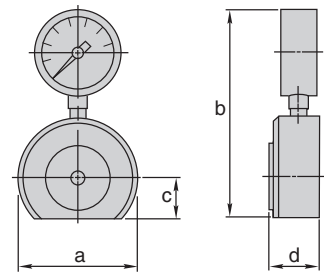
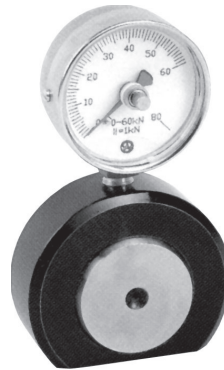

Handy gauge for measuring clamping force in hydraulic or mechanical clamping systems. Flat side allows easier positioning in-line with the clamping force, especially for vises. Choice of two force ranges.

Right-Angle Drive Units

Part No.	Fits Jaw Width	Drive Hex Size	Crank Throw	b	Weight (lbs)
CLRH-3294-05-VSA	100mm	10mm	4.92	1.54	.5
CLRH-3294-06-VSA	125mm			1.69	1.0
CLRH-3294-07-VSA	160mm			1.81	2.0

Force Gauges (Load Cells)

Part No.	Indicating Range	a dia	b	c	d
CLRH-2-9501-0001-VSA	0-60 kN (0-13,500 lbs)	3.46	5.91	1.14	1.46
CLRH-2-9501-0002-VSA	0-100 kN (0-22,500 lbs)	5.43	7.87	2.13	1.57

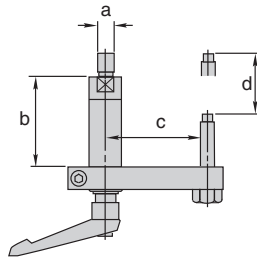
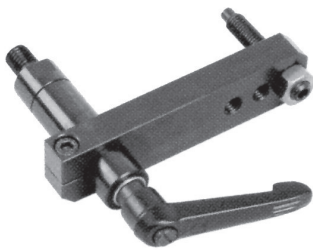

A precision workpiece stop that mounts into either side of the vise body. Reposition swing arm on the shaft by loosening the socket-head cap screw. Can be used as a swing-away stop, with the rapid-locking handle.

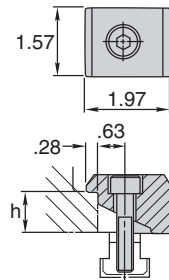
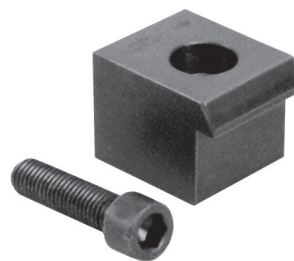

Set of four clamps with screws, for mounting one vise.

Adjustable Side Stops

Part No.	Fits Jaw Width	a	b max	c max	d max
CLRH-3291-02-VSA	100mm and 125mm	M12	2.40	3.74	1.81
CLRH-3291-03-VSA				4.13	
CLRH-3291-04-VSA	160mm	M16	3.19	4.88	2.60

Vise Clamps

Part No.	Fits Jaw Width	h	Socket-Head cap screws (furnished)
CLRH-9-3777-2011-VSA	100mm	.94	M12x45mm long
CLRH-9-3777-3011-VSA	125mm and 160mm	1.06	M12x45mm long
CLRH-9-3777-3021-VSA			M16x50mm long



ROEMHELD
HILMA ■ STARK

Carr Lane Roemheld Mfg. Co.

Sales — Phone (314) 647-6200 Fax (314) 647-5736
Engineering — Phone 1-800-827-2526 Web roemheld-usa.com

CARVESMART™ QUICK CHANGE VISE JAWS

QUICK • ACCURATE VERSATILE • STURDY

The patented CARVESMART™ Quick-Change Vise Jaw System is a complete package of dovetailed jaws for production and toolroom vises that are accurately changed in seconds.

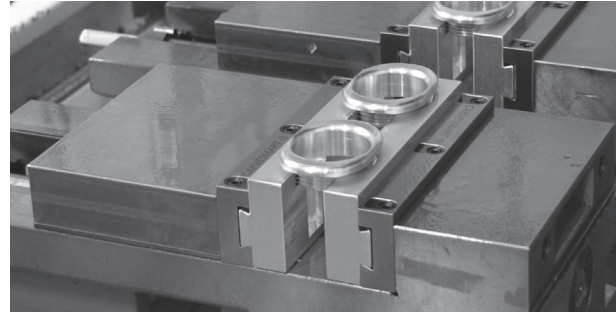

- CLAMP NUTS: 1018 steel with QPQ wear and corrosion resistant surface treatment.
- SPEED SCREWS: Black oxidized, alloy steel differential screw. RH/LH travel moves twice as fast, lifts and pulls without gauling.
- SMARTstop™ is an internal-to-the-jaw set, slot and pin system for jobs that repeat.
- Extruded jaw stock can be cut to any length from 1/2" to 94", available in five profiles.
- Fully accessorized with dovetailed hard jaws, PERMAjaws and 1018 steel jaws.

Save \$\$ When Bundled with the NC Vise

Our NC vise is available with an *integrated force gauge* which tells you how much holding force is being applied to your workpiece. Minimal effort on the crank handle results in extremely high holding force because of the built-in hydraulic power of the vise. Now you'll know if your part is being held properly.

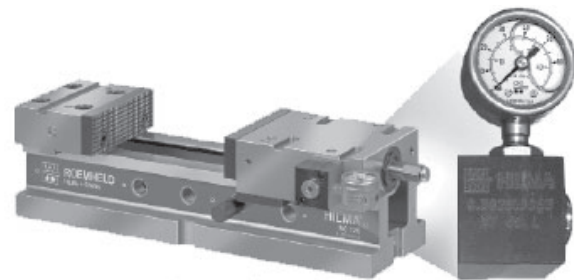

- Better clamping quality
- Correct clamping force every time
- Consistent process control
- Reduced tool breakage
- Workpiece deformation reduced
- Ideal for roughing and finishing
- Reduced operator fatigue

Visit clrh.com/carvesmart for more details, and to watch the video!



CL5 Quick-Change Five-Axis Workholding

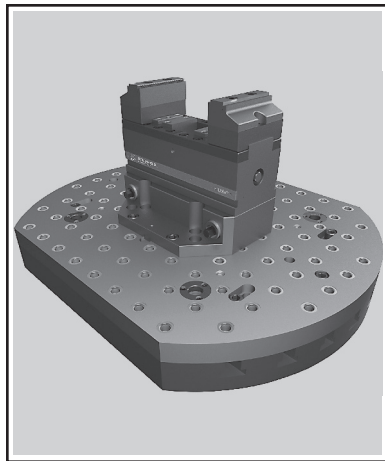

**Subplate Mounted
On a Rotary Table**

- **Designed specifically for 5-axis machining**
- **Also suitable for standard machining**
- **INFO+: Use in conjunction with the vises and jaws in the next few pages, as well as the subplates on pages 373-394**

DESCRIPTION: The CL5® quick-change, 5-Axis workholding system consists of three components: a subplate, a riser, and top tooling made up of a vise or a fixture plate. The subplate transforms a T-slot table into a modular fixturing plate, allowing flexible and easy clamping and locating of other tooling and/or fixtures. Designed to get the part up from the machine table, the Quintus quick-change riser allows 5-side part access. The Quintus combines the riser, quick-change capability and precise location in one piece.

APPLICATIONS: The CL5® systems offers three primary methods of fixturing:

METHOD 1: Fixture Plate Mounted on a Rotary Table. This method is ideal for small rotary tables up to 210mm diameter. Fixture plates are accurately located and fastened directly to the rotary table.

METHOD 2: Quintus Quick-Change Riser Mounted on Rotary Table. The method provides additional height for spindle clearance. It allows you to quickly and accurately mount directly on rotary tables 250mm diameter and larger.

METHOD 3: Subplate Mounted on Rotary Table. This method is appropriate for all machines. The Quintus riser is mounted on a subplate to allow quick exchange of the riser with other fixturing.

Top Tooling Connects Directly to the Quintus Quick-Change Riser

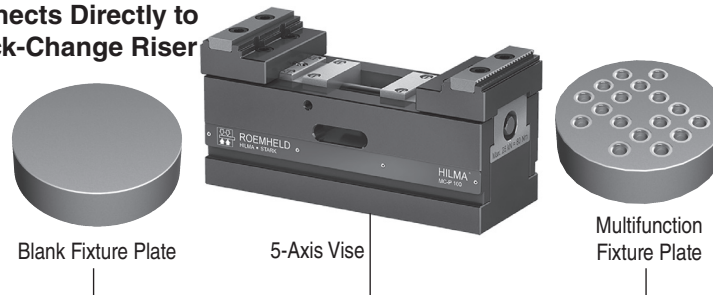

Quintus Quick-Change Riser Connects to Any Subplate, No Extra Adaptors Required

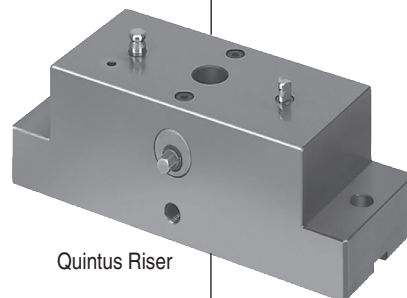

Use Subplate Alone or With Risers and Plates
INFO+: See Subplates pages 373-394

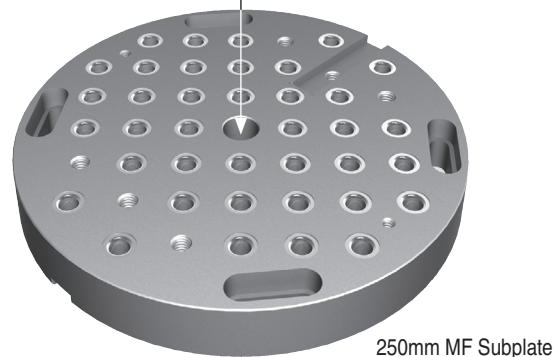

Subject to change. For further details, including detailed dimensions and mounting instructions, visit roemheld-usa.com.



ROEMHELD
HILMA ■ STARK

Carr Lane Roemheld Mfg. Co.
Sales — Phone (314) 647-6200 Fax (314) 647-5736
Engineering — Phone 1-800-827-2526 Web roemheld-usa.com

Quick-Change Five-Axis Workholding ■ MC-P Machining Vise

5-Axis MC-P Vise ■ Mechanically or Hydraulically Operated
 Allows unrestricted tool access for 5-sided machining

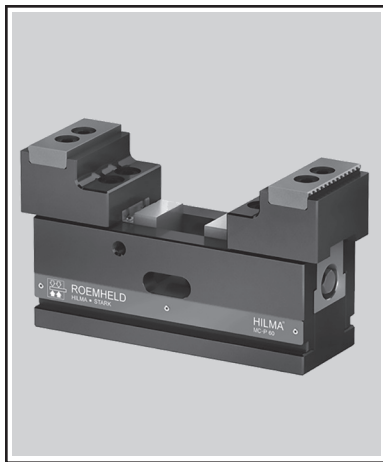

MC-P Series Fixed Jaw Vise
 INFO+: Page 651

- Mechanically operated
- Jaw widths: 40, 60, 100 and 125 mm
- Conventional vise style with one fixed and one moving jaw
- Jaws not included, standard versions of jaws available



MC-P Z Series Concentric Vise
 INFO+: Page 652

- Mechanically or hydraulically operated
- Jaw widths: 40, 60, 100, 125 mm
- Two moving jaws that provide exact centering of the workpiece
- Jaws not included, standard versions of jaws available



MC-P ZB Series Position Flexible Vise
 INFO+: Pages 653

- Mechanically operated
- Jaw widths: 60, 100, 125 mm
- Two moving jaws that provide exact centering of the workpiece
- Clamping without deformation of workpieces by position flexible clamping point
- Jaws not included, standard versions of jaws available

Quintus Quick-Change Riser

INFO+: See page 668 for more details

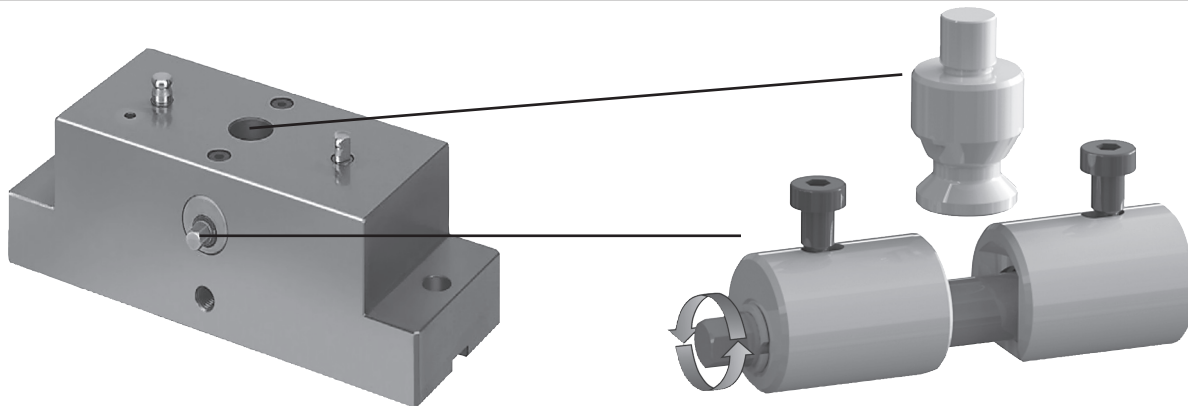

Quintus Clamping Mechanism

Quintus Clamping Mechanism

Subject to change. For further details, including detailed dimensions and mounting instructions, visit roemheld-usa.com.



ROEMHELD
 HILMA ■ STARK

Carr Lane Roemheld Mfg. Co.

Sales — Phone (314) 647-6200 Fax (314) 647-5736
 Engineering — Phone 1-800-827-2526 Web roemheld-usa.com

Quick-Change Five-Axis Workholding ■ MC-P Fixed Jaw ■ WS 5.4501

MC-P Fixed Jaw Vise ■ Mechanically Operated Jaw Widths 40, 60, 100 and 125 mm

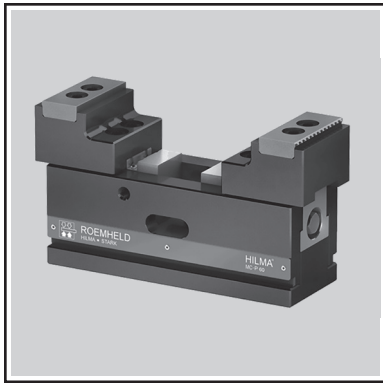

The workholding MC-P vises are especially advantageous for 5-axis machining. The patented three piece segment design allows for a high degree of precision. All essential components are made of hardened steel. Thanks to raising the spindle arranged in the upper part of the housing, deformation in the base during max. clamping is reduced significantly, improving stability and precision of the work-piece. The high force and stability eliminate the need for pre-stamping.

Compact design allows for collision-free tool paths and access to all 5 sides with short standard tools. Due to the predesigned swarf protection, they are particularly suitable for the use in pallet systems. The MC-P 100/125 are equipped to use on zero point clamping systems with threads for retractable nipples at the bottom side of the housing (nipples and pictured jaws not included). These clamps are intended to be used with hydraulic fluid only.

Application Example

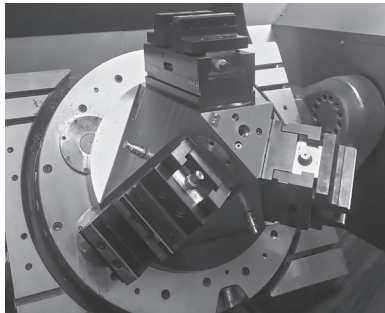

3 workholding systems MC-P in 3 x 120° arrangement on a 5-axis machining center.

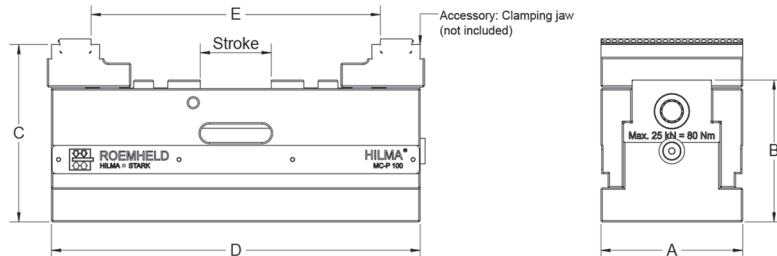
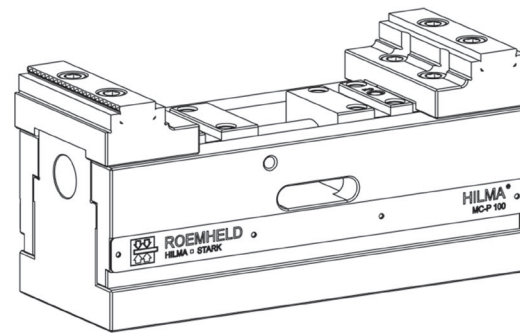

Accessories

- Clamping jaws and jaw inserts, accessories for mounting, positioning and operation see data sheet WS 5.450Z
- Rapid change block Quintus see data sheet WS 5.6150

Customized Versions

MC-P workholding systems can also be delivered as customized versions. For example in hydraulically-operated versions, other lengths or with individual mounting holes. Please contact us.

Operation Type	Manual MC-P 40	Manual MC-P 60	Manual MC-P 100	Manual MC-P 125
Jaw Width (mm)	40	60	100	125
Clamping force (lbs) / Torque (ft-lbs)	1685 / 17	3370 / 37	5620 / 59	7870 / 147
Clamping stroke (in.)	0.79	1.18	1.97	3.97
A (in.)	1.57	2.36	3.94	4.92
B (in.)	2.05	2.75	3.94	5.12
C (in.)	2.52	3.46	4.92	6.30
D (in.)	4.33	6.69	10.24	11.14
E (in.)*	3.11	5.90	8.03	8.46
Weight (lbs) without clamping jaws	3.31	10.14	38.58	77.16
Part No., without clamping jaws	CLRH-9-4581-0101	CLRH-9-4583-0101	CLRH-9-4585-0101	CLRH-9-4586-0101

*Depending on the used clamping jaw

Subject to change. For further details, including detailed dimensions and mounting instructions, visit roemheld-usa.com.



ROEMHELD
HILMA ■ STARK

Carr Lane Roemheld Mfg. Co.
Sales — Phone (314) 647-6200 Fax (314) 647-5736
Engineering — Phone 1-800-827-2526 Web roemheld-usa.com

MC-P Z Concentric Vise ■ Mechanically or Hydraulically Operated
 Jaw Widths 40, 60, 100 and 125 mm

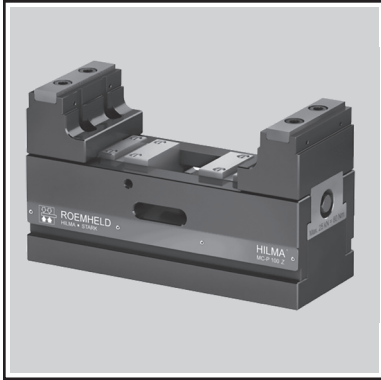

The workholding MC-P vises are especially advantageous for 5-axis machining. The patented three piece segment design allows for a high degree of precision. All essential components are made of hardened steel. Thanks to raising the spindle arranged in the upper part of the housing, deformation in the base during max. clamping is reduced significantly, improving stability and precision of the work-piece. The high force and stability eliminates the need for pre-stamping.

Compact design allows for collision-free tool paths and access to all 5 sides with short standard tools. Due to the predesigned swarf protection, they are particularly suitable for the use in pallet systems. The MC-P Z 100/125 are equipped to use on zero point clamping systems with threads for retractable nipples at the bottom side of the housing (nipples and pictured jaws not included).

Application Example

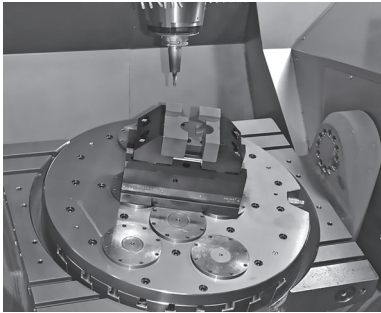

Workholding system MC-P with workpiece specific base jaw and form jaw used on a 5-axis machining center.

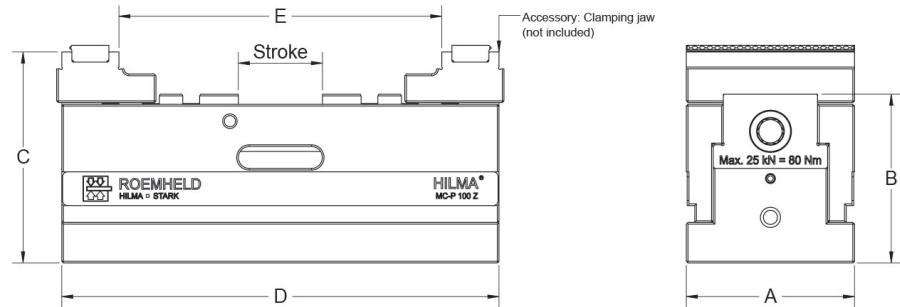

Accessories

- Clamping jaws and jaw inserts, accessories for mounting, positioning and operation see data sheet WS 5.450Z
- Rapid change block Quintus see data sheet WS 5.6150
- Hydraulic pressure generators on request

Customized Versions

MC-P workholding systems can also be delivered as customized versions. For example with other lengths, height or with individual mounting holes. Please contact us.

* Depending on the used clamping jaw

Subject to change. For further details, including detailed dimensions and mounting instructions, visit roemheld-usa.com.



Carr Lane Roemheld Mfg. Co.

Sales — Phone (314) 647-6200 Fax (314) 647-5736

Engineering — Phone 1-800-827-2526 Web roemheld-usa.com

MC-P Z Balance Position Flexible Vise ■ Mechanically Operated
Jaw Widths 60, 100 and 125 mm



The workholding MC-P ZB vises are especially advantageous for 5-axis machining. It has a position flexible clamping point. This allows for similar workpiece with a variable clamping point to be utilized in the same fixture. The jaws move concentrically to the clamping point on the prelocated fixed workpiece. Once one jaw makes contact to the part the opposite jaw is the only one going to travel. When both jaws make contact with the workpiece, the desired clamping force is applied by means of a torque wrench. This does not deform the workpiece because the clamping point is still floating. Finally the locking spindle is used to lock the jaws into place.

The patented three piece segment design allows for a high degree of precision. All essential components are made of hardened steel. Thanks to raising the spindle arranged in the upper part of the housing, deformation in the base during max. clamping is reduced significantly, improving stability and precision of the workpiece. The high force and stability eliminates the need for pre-stamping. Compact design allows for collision-free tool paths and access to all 5 sides with short standard tools. Due to the predesigned swarf protection, they are particularly suitable for the use in pallet systems. The MC-P ZB 100/125 are equipped to use on zero point clamping systems with threads for retractable nipples at the bottom side of the housing (nipples and pictured jaws not included).

Application Example

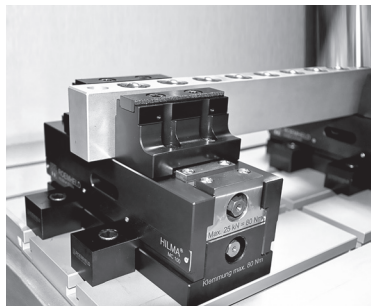

Clamping of aluminium bars with workholding system MC-P 100 Z Balance.

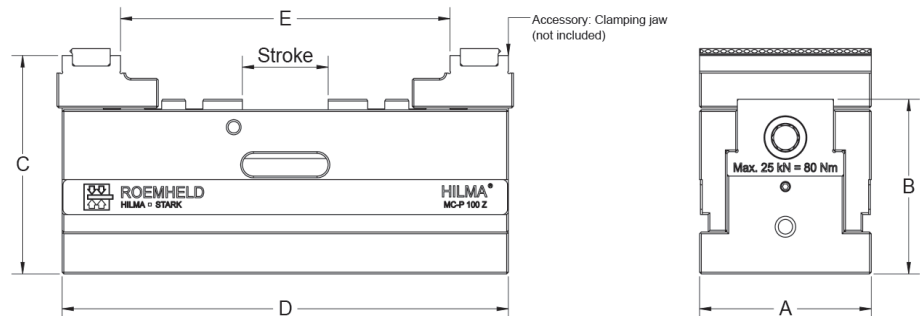

Accessories

- Clamping jaws and jaw inserts, accessories for mounting, positioning and operation see data sheet WS 5.450Z
- Rapid change block Quintus see data sheet WS 5.6150

Customized Versions

MC-P Z Balance workholding systems can also be delivered as customized versions. For example with other lengths or with individual mounting holes. Please contact us.

Operation	Manual	Manual	Manual
Type	MC-P 60 ZB	MC-P 100 ZB	MC-P 125 ZB
Jaw Width (mm)	60	100	125
Clamping force (lbs) / Torque (ft-lbs)	3370 / 37	5620 / 59	7870 / 147
Clamping stroke (in.)	1.18	1.97	3.97
A (in.)	2.36	3.94	4.92
B (in.)	2.75	3.94	5.12
C (in.)	3.46	4.92	6.30
D (in.)	6.69	10.24	18.31
E (in.)*	5.90	8.03	15.75
Weight (lbs) without clamping jaws	10.14	38.58	115.30
Part No., without clamping jaws	CLRH-9-4583-0701	CLRH-9-4585-0701	CLRH-9-4586-0701

* Depending on the used clamping jaw

Subject to change. For further details, including detailed dimensions and mounting instructions, visit roemheld-usa.com.



ROEMHELD
 HILMA ■ STARK

Carr Lane Roemheld Mfg. Co.
 Sales — Phone (314) 647-6200 Fax (314) 647-5736
 Engineering — Phone 1-800-827-2526 Web roemheld-usa.com

Quintus Riser ■ Quick-Change Riser
Max. Retention Force per Clamping Pin ■ 4500 lbs

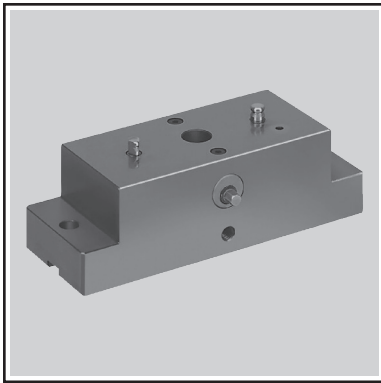

Quintus 1
Quick Change Riser

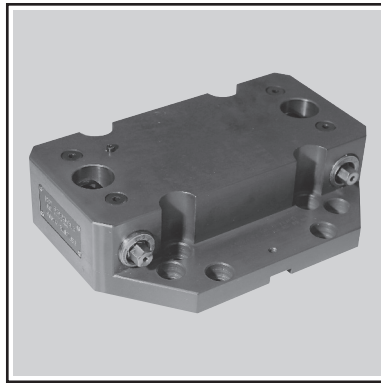

Quintus 2
Quick Change Riser

- Vises and fixture plates mount directly onto the Quintus Quick-Change Riser
- Two sizes
- Extremely accurate

The CL5® quick-change, 5-Axis workholding system consists of three components: a subplate, a riser, and top tooling made up of a vise or a fixture plate. The subplate transforms a T-slot table into a modular fixturing plate, allowing flexible and easy clamping and locating of other tooling and/or fixtures. Designed to get the part up from the machine table, the Quintus quick-change riser allows 5-side part access. The Quintus combines the riser, quick-change capability and precise location in one piece.

Quick Change for Non-Quintus Riser
see data sheet WS 5.6150.

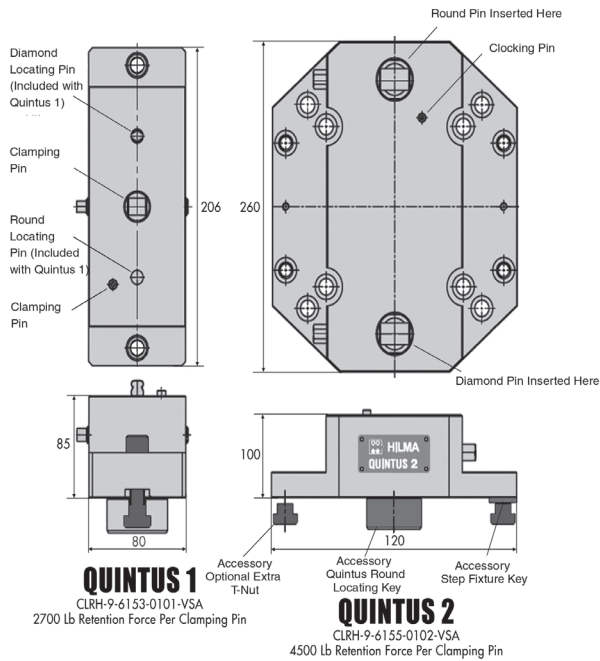

Round Locating Key
for Quintus 1, 2

PART NO.	Ømm	L1 / L2
CLR-9-6153-5001-VSA	D 30 g6	15/38
CLR-9-6153-5002-VSA	D 32 g6	15/38
CLR-9-6153-5003-VSA	D 50 g6	25/48
CLR-9-6153-5009-VSA	D 50 g6	18/41

Step Fixture Key
CLM-6x16-SHCS screw required

PART NO.	FIXTURE SLOT	TABLE SLOT
CLR-9-6153-5004-VSA	20mm	14mm
CL-20-SFK-16	20mm	16mm
CL-20-SFK-18	20mm	18mm
CLM-20-FK	20mm	20mm

Quintus Pin Sets

PART NO.	INCLUDES
CLR-9-3920-0201-VSA	QUINTUS 1 - w/o Centering
CLR-9-3920-0202-VSA	QUINTUS 2 - Round & Diamond Pin

Positioning Pin
for Quintus 2. (1 piece)

PART NO.	Ømm
CLR-9-3920-0102-VSA	10/14 h6

T-Nut
with screw (set of 4)

PART NO.	T-SLOT (mm)
CLR-9-6153-5005-VSA	14

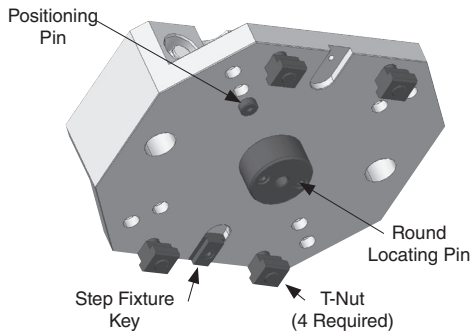







Bottom View of Quintus 2

Subject to change. For further details, including detailed dimensions and mounting instructions, visit roemheld-usa.com.

MC-P Vise Jaws ■ Clamping Jaws
Jaw Widths 40, 60, 100 and 125 mm

Scope of delivery - clamping jaws

All clamping jaws are supplied with fastening screws.
Reversible step jaws are always delivered without jaw inserts.
For more accessories and jaw inserts option (see data sheet WS 5.450Z).

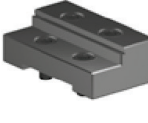
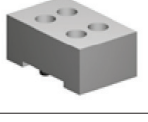
			MC-P 40, Z	MC-P 60, Z, ZH, ZB	MC-P 100, Z, ZH, ZB	MC-P 125, Z, ZH, Z Compact, ZB
	Step Jaw - Flat	Reversible step jaw, hardened and ground, (without jaw inserts)	-	CLR9-9-4583-6901	CLR9-9-4585-6901	CLR9-9-4585-6901
	Step Jaw - Wide	Reversible, interchangeable standard insert, one side serrated, one side smooth, may be replaced with custom inserts, (without jaw inserts)	-	CLR9-9-4583-6902	CLR9-9-4585-6902	CLR9-9-4586-6902
	Step Jaw - Medium		-	CLR9-9-4583-6903	CLR9-9-4585-6903	CLR9-9-4586-6903
	Step Jaw - Narrow		-	-	CLR9-9-4585-6904	-
	Pendulum Jaw	For compensating non-parallel clamping surfaces, hardened and ground (without jaw inserts)	-	-	CLR9-9-4585-6905	CLR9-9-4586-6905
	Vee Jaw	Vee Jaw with removable insert for increased part range, hardened	-	CLR9-9-4583-6921	CLR9-9-4585-6921	-
	Step Jaw	Reversible step jaw, 2 steps, hardened	CLR9-9-4581-6931	CLR9-9-4583-6931	CLR9-9-4585-6931	CLR9-9-4586-6931
	Soft Jaw	Machinable soft jaw	CLR9-9-4581-6932	CLR9-9-4583-6932	CLR9-9-4585-6932	CLR9-9-4586-6932

INFO+: The jaws on this page are designed to be used with the 5-axis machining vises on pages 665-667

Subject to change. For further details, including detailed dimensions and mounting instructions, visit roemheld-usa.com.



ROEMHELD
HILMA ■ STARK

Carr Lane Roemheld Mfg. Co.
Sales — Phone (314) 647-6200 Fax (314) 647-5736
Engineering — Phone 1-800-827-2526 Web roemheld-usa.com

Concentric Vises

**2175 psi max clamp
290 psi max unclamp**

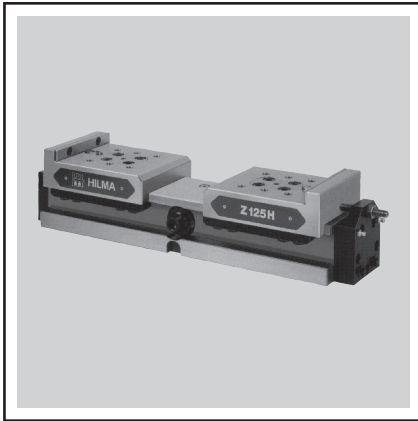

Hydraulic Concentric

- High clamping repeatability ± 0.01 mm
- Constant length and large clamping ranges
- Any mounting position
- Possibilities for positioning and fastening customer-specific jaws
- Protection against coolant and swarf by integral wipers in the clamping slides
- Large stroke of the slide
- Limitation of the opening stroke by an adjustable set screw
- An additional pilot-controlled check valve can be fitted to the 'clamping' port

DESCRIPTION: Self-centering vises position and clamp workpieces exactly on a defined symmetrical axis, taking account of their contours.

They may be used in machining centers, on machine tools and final processing machines as well as in special jigs and fixtures.

Hydraulic clamping and unclamping is powered by an external pressure transmitter with a double-acting circuit.

The adjustable synchronizing device ensures high centering precision.

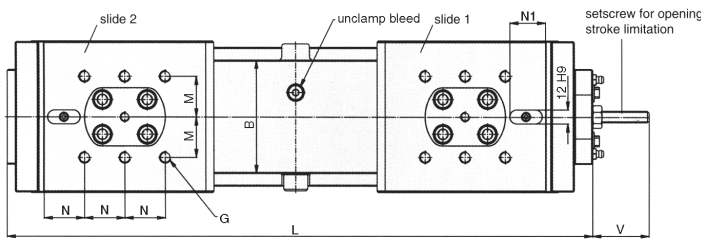

Connections:
 Port A - clamping
 Port B - unclamping
 S1 - oil lubrication slide 1
 S2 - oil lubrication slide 2

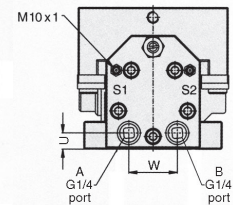
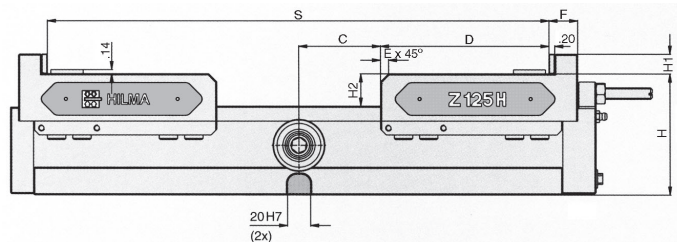
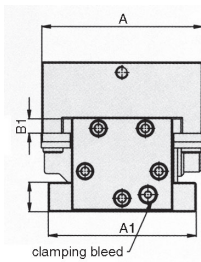

Includes:

- Fitting key, positioning and mounting holes for standard and special jaws
- Keyway across the length for positioning
- Clamping edge for claws
- Lubrication nipples and connections, respectively, for central lubrication.
- Oil ports 1/4 BSPP, A - clamping, B - unclamping

INSTALLATION (EXAMPLE) For hydraulic oil supply, pump units working intermittently are preferred. In the clamped position, the directional valves are idle, and the operating pressure is maintained by an integral check valve.

Two pressure switches (pump control and machine safety) monitor the adjusted operating pressure.

Clamping and unclamping can be controlled by hand-operated valves, by selector or foot-operated switch or, fully automatic, by signals.

Do not exceed 300 psi on unclamp circuit. Recommended power unit CLR-886-EP.

Jaw Width (A)	100mm 3.937"	125mm 4.921"	160mm 6.299"
Max. clamping force (lbs)	3595	5620	8990
Power stroke/slide (in.)	0.87	1.38	1.77
Max. operating pressure (psi)	2175/290	2175/290	2175/290
Fluid required (cu.in.)	3.7	8.4	17
A	3.937	4.921	6.299
A1	3.937	4.724	5.59
B	2.91	3.86	7.8
B1	0.39	0.51	0.59
C	1.69	2.8	2.95
D	4.53	5.79	7.28
E	0.28	0.28	0.39
F	0.98	0.98	1.18
G	M8x12	M10x15	M12x18
H	3.74	4.13	4.92
H1	0.63	0.67	0.79
H1	1.02	1.1	1.34
L	15.35	19.69	23.62
M	1.18	1.38	1.57
N	0.98	1.38	1.97
N1	0.98	1.26	1.26
S	12.44	17.17	20.47
U	0.51	0.55	0.63
V	1.30	1.93	2.36
W	1.42	1.65	1.81
Weight (lbs)	49	86	150
Part No.	CLR-9-3542-0101-VS	CLR-9-3543-0101-VS	CLR-9-3544-0101-VS
Part No. with Proximity Switches	CLR-9-3542-0201-VS	CLR-9-3543-0201-VS	CLR-9-3544-0201-VS

Subject to change. For further details, including detailed dimensions and mounting instructions, visit roemheld-usa.com.



ROEMHELD
 HILMA ■ STARK

Carr Lane Roemheld Mfg. Co.

Sales — Phone (314) 647-6200 Fax (314) 647-5736

Engineering — Phone 1-800-827-2526 Web roemheld-usa.com

Concentric Vises

2175 psi max to clamp
290 psi max to unclamp



Jaws Quoted
Upon Request.

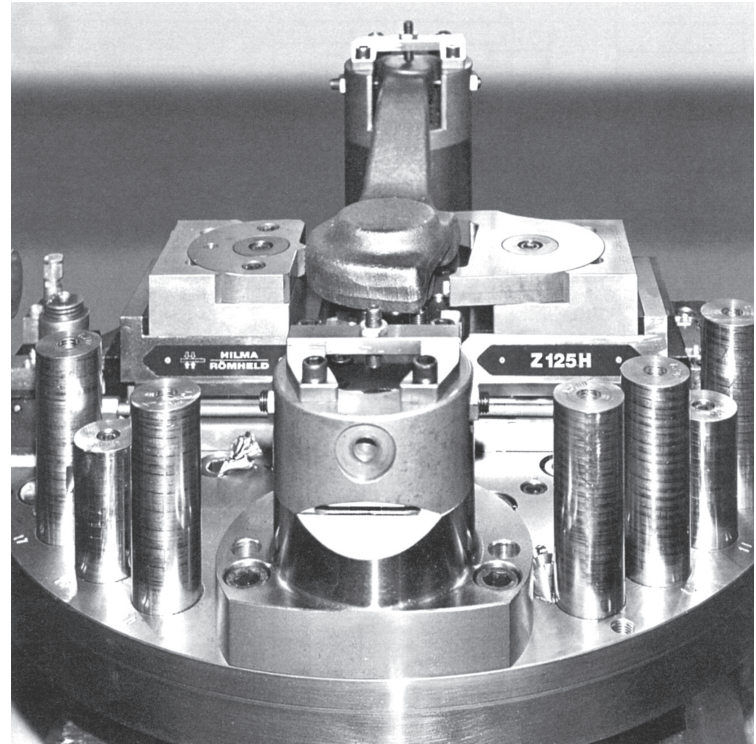

Self-centering vise, hydraulically operated

Drill template for customized fastening

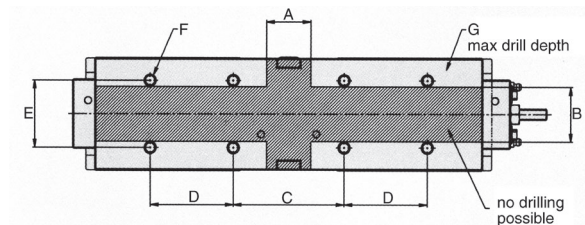

Type	A	B	C	D	E	F	G
Z 100 H	1.58	1.93	3.94	2.95	2.36	M10x15	.78
Z 125 H	1.78	2.17	6.46	3.27	2.68	M12x20	.86
Z 160 H	2.17	2.37	6.30	4.72	3.15	M12x20	.86

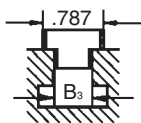

Set of tenon blocks
DIN 6323

Accessories

Part No.	Slot in the machine bed
CLRH-3917-4121-VSA	14h6 (B3)
CLRH-3917-4141-VSA	18h6 (B3)

1 set = 2 blocks

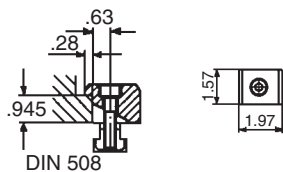

Set of clamping claws with
screws M12x45

Part No.	For safe clamping on the machine bed
CLRH-3777-2011-VSA	1 set = 4 claws



ROEMHELD
HILMA ■ STARK

Carr Lane Roemheld Mfg. Co.

Sales — Phone (314) 647-6200 Fax (314) 647-5736
Engineering — Phone 1-800-827-2526 Web roemheld-usa.com

Modular Zero-Point System ■ DropZero™

DropZero ■ 5-Axis System ■ Locates, Clamps and Supports a Workpiece
Manual Operation ■ Max. Retention Force ■ 2700 lbs

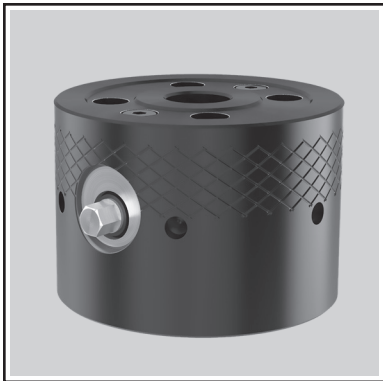

- Reduces setup time and fixturing costs
- Modular design works with all of CLM's 1/2" and 5/8" modular tooling
- Can also be used with non-modular tooling
- Elevates workpiece for machine spindle clearance
- Access to all 5 sides of the part
- Stackable for added clearance
- High stability due to robust and wide design

New item!

With a few turns of a wrench, new DropZero Modular Zero-Point System quickly unloads and loads new parts in one setup, all while having access to all five sides of the workpiece. Pull studs (round, diamond, and floating) are mounted directly to a part, and clamp modules can be mounted to any fixture plate and can be stacked for added height. DropZero gives you better part quality due to a completely machined part in one setup, reduced fixturing costs, and simpler tool paths.

Application Examples

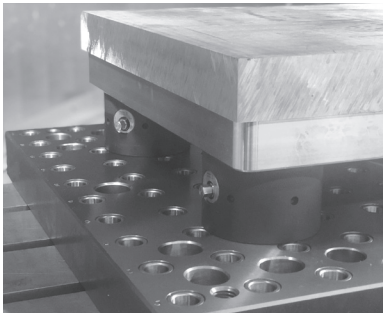

Four DropZeros mounted on a Carr Lane Mfg. modular fixturing plate holding an aluminum billet part.

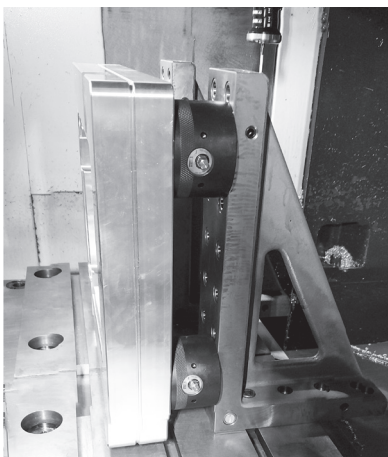

Example of side work for vertical applications.

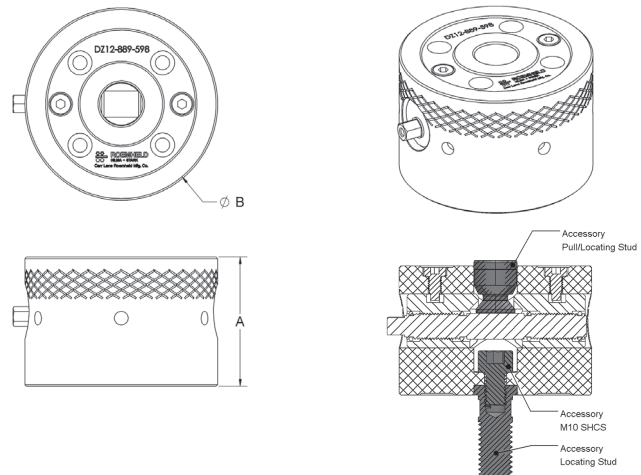

Operation	Manual
Type	Zero Point Mounting
Retention force (lbs) / Torque (ft-lbs)	2700 lbs/ 45 ft-lbs [12 kN/ 60 Nm]
A (in.)	2.35 ± 0.0004 in [59.8 ± 0.01 mm]
Ø B (in.)	3.50 in [88.9 mm]
Weight (lbs)	5.64 lbs [2.56 kg]
Part No.	CLR-DZ12-889-598
Pallet Change Repeatability	≤ 0.0004 in [0.01 mm]

Accessories

Part No., housing unit only	CLR-DZ12-889-598-H
Part No., zero-point locating stud/screw (1/2-13 UNC-2A)	CLR-DZ12T-500Z
Part No., zero-point locating stud/screw (5/8-11 UNC-2A)	CLR-DZ12T-625Z
Part No., socket-head cap screw	CLR-M10-1.50X16-SHCS
Part No., clamping spindle	CLR-DZ12M-25
Part No., zero-point pull stud	CLR-DZ12N-20Z
Part No., diamond pull stud	CLR-DZ12N-20D
Part No., floating pull stud	CLR-DZ12N-20F
Part No., floating pull stud without pallet/part, locating shoulder	CLR-DZ12N-195
Part No., locating dowel	CLR-DZ12D-15
Custom standoff	Available on request

Subject to change. For further details, including detailed dimensions and mounting instructions, visit roemheld-usa.com.

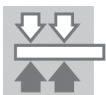

ROEMHELD
HILMA ■ STARK

Carr Lane Roemheld Mfg. Co.

Sales — Phone (314) 647-6200 Fax (314) 647-5736

Engineering — Phone 1-800-827-2526 Web roemheld-usa.com

Pull Studs

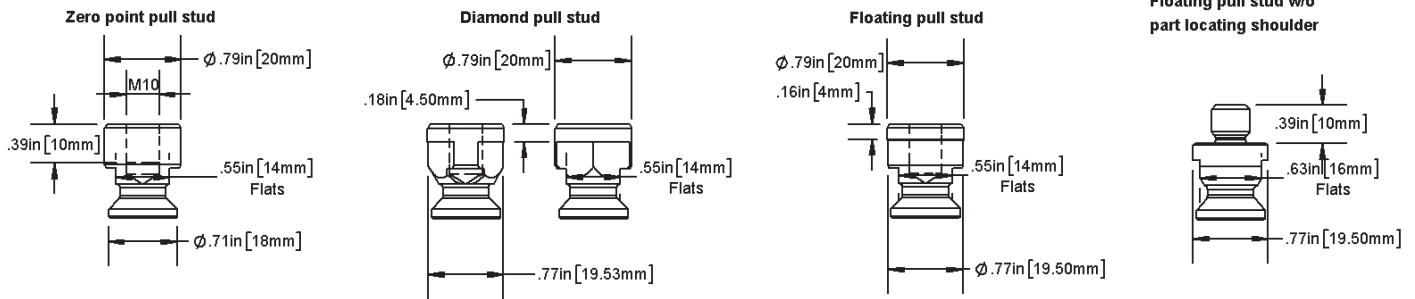

Pull Stud Mounting Options

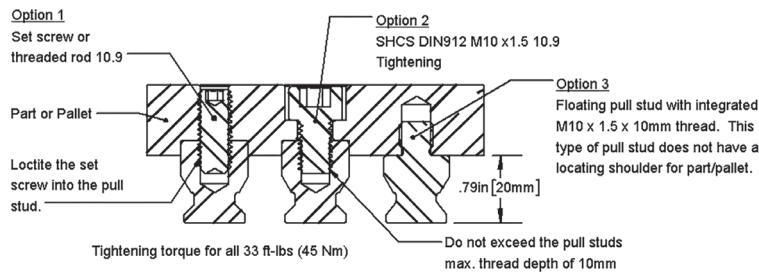

Pull Stud Mounting Options

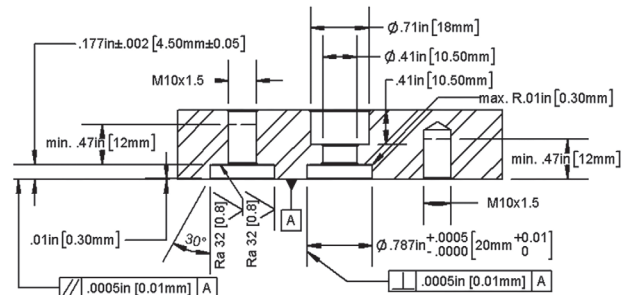

Locating Studs for Modular Tooling

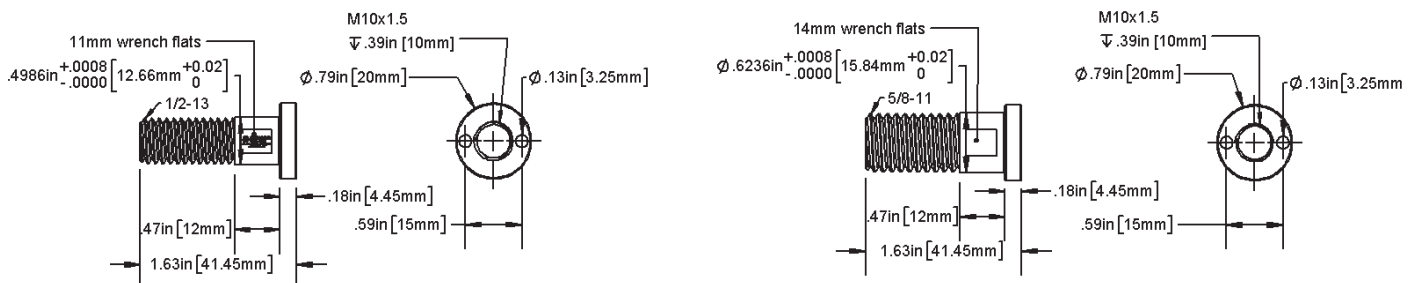

Subject to change. For further details, including detailed dimensions and mounting instructions, visit roemheld-usa.com.

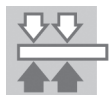

ROEMHELD
HILMA ■ STARK

Carr Lane Roemheld Mfg. Co.
 Sales — Phone (314) 647-6200 Fax (314) 647-5736
 Engineering — Phone 1-800-827-2526 Web roemheld-usa.com

DropZero ■ 5-Axis System ■ Mounting Options

Tilting torque calculation example

Benefit from our specialist competence

Example:

DropZero clamps, 4x, with 200 x 200 mm spacing and max. feed thrust force of 7 kN with distance of 400 mm.

Question:

Due to the predominance of roughing work, the system should be checked for 2x safety factor. Is the retention force, number of DropZero clamps and the selected spacing right for this application?

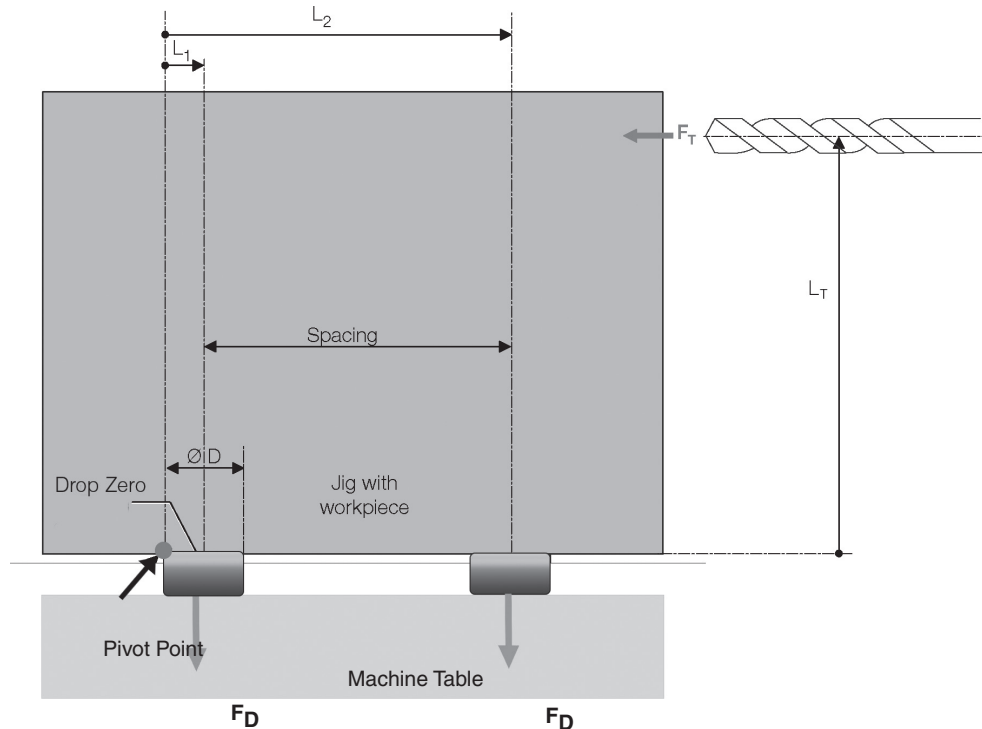

Solution:

$$M_D > 2 \times M_T ?$$

$$M_T = F_V \times L_V = 7,000 \text{ N} \times 0.4 \text{ m}$$

$$M_T = \mathbf{2,800 \text{ Nm}}$$

$$M_D = 2 \times (F_D \times L_1) + 2 \times (F_D \times L_2)$$

$$M_D = 2 \times F_D \times (L_1 + L_2)$$

$$L_1 = \text{ØD} / 2 = 0.0889 / 2 = 0.04445$$

$$L_2 = \text{ØD} / 2 + \text{Spacing} = 0.04445 + 0.20 = 0.24445$$

$$L_1 + L_2 = \text{ØD} + \text{Spacing}$$

$$L_1 + L_2 = 0.0889 \text{ m} + 0.20 \text{ m} = 0.2889 \text{ m}$$

$$M_D = 2 \times F_D \times (L_1 + L_2) = 2 \times 12,000 \text{ N} \times 0.2889 \text{ m}$$

$$M_D = \mathbf{6,933.6 \text{ Nm}}$$

$$M_D / M_T > 2 ?$$

$$M_D / M_T = 6,933 \text{ Nm} / 2,800 \text{ N} \quad M_D / M_T = \mathbf{2.4 > 2} \checkmark$$

With this design, a safety factor of two is provided. All dimensions to be entered in SI units (meters, Newtons).

M_T : Moment from Feed Thrust Force

M_D : Moment from Retention force

F_T : Feed Thrust Force (7,000 N)

F_D : Retention force (12,000 N)

Spacing = 200 mm = 0.20 m

Ø D: 88.9 mm = 0.0889 m

L_T : 400 mm = 0.40 m



Modular Zero-Point System ■ DropZero® ■ Bundle Kits

Application Examples Of Pull Stud Arrangements

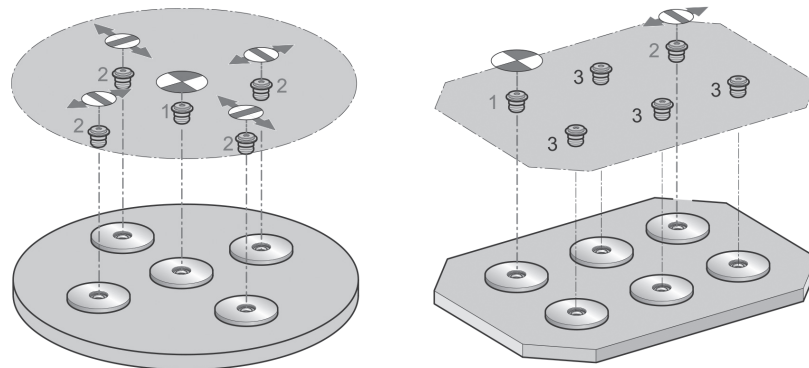

Standard Pull Stud Kits

Every standard Pull Stud Kit comes with at least one Zero-Point Pull Stud, one Diamond Pull Stud and one Locating Dowel. These are good for applications that require high repeatability between change overs.

Bundle Kit Part No.*	Quantities in Each Kit					
	DropZero CLR-DZ12-889-598	Locating Dowel CLR-DZ12D-15	Cap Screw CLR-M10-1.50X16-SHCS	Zero Point (Round) Pull Stud CLR-DZ12N-20Z	Diamond Pull Stud CLR-DZ12N-20D	Floating Pull Stud CLR-DZ12N-20F
CLR-DZ12K-2S	2	2	2	1	1	-
CLR-DZ12K-3S	3	3	3	1	1	1
CLR-DZ12K-4S	4	4	4	1	1	2
CLR-DZ12K-5S	5	5	5	1	1	3
CLR-DZ12K-6S	6	6	6	1	1	4

* Add "F" to the end of any of the above part numbers to make all the pull studs in the kit "Floating Pull Studs" part number CLR-DZ12N-20F.

* Add "-500" to the end of any of the above part numbers to replace the CLR-DZ12D-15 Locating Dowels with CLR-DZ12T-500Z 1/2-13 Locating Studs for use with Carr Lane Mfg. modular tooling.

* Add "-625" to the end of any of the above part numbers to replace the CLR-DZ12D-15 Locating Dowels with CLR-DZ12T-625Z 5/8-11 Locating Studs for use with Carr Lane Mfg. modular tooling.

Non-Standard Pull Stud Kits

Non-standard Pull Stud Kits come with Locating Dowels and our Floating Pull Stud that does not have a locating shoulder for mating with your part or pallet. These are best used for setup applications that do not require high repeatability between change overs or when probing will be done prior to machining.

Bundle Kit Part No.*	Quantities in Each Kit			
	DropZero CLR-DZ12-889-598	Locating Dowel CLR-DZ12D-15	Cap Screw CLR-M10-1.50X16-SHCS	Floating pull stud without pallet/ part locating shoulder CLR-DZ12N-195
CLR-DZ12K-2F	2	2	2	2
CLR-DZ12K-3F	3	3	3	3
CLR-DZ12K-4F	4	4	4	4
CLR-DZ12K-5F	5	5	5	5
CLR-DZ12K-6F	6	6	6	6

* Add "-500" to the end of any of the above part numbers to replace the CLR-DZ12D-15 Locating Dowels with CLR-DZ12T-500Z 1/2-13 Locating Studs for use with Carr Lane Mfg. modular tooling.

* Add "-625" to the end of any of the above part numbers to replace the CLR-DZ12D-15 Locating Dowels with CLR-DZ12T-625Z 5/8-11 Locating Studs for use with Carr Lane Mfg. modular tooling.

Subject to change. For further details, including detailed dimensions and mounting instructions, visit roemheld-usa.com.



ROEMHELD
HILMA ■ STARK

Carr Lane Roemheld Mfg. Co.
Sales — Phone (314) 647-6200 Fax (314) 647-5736
Engineering — Phone 1-800-827-2526 Web roemheld-usa.com

Vises ■ Fixture Clamps ■ I4.110 & I4.111

Fixture Clamps with Fixed Jaw ■ Compact vise with jaw widths 1.57" and 2.56" Double Acting ■ Max. Operating Pressure ■ 3625 psi (250 bar)

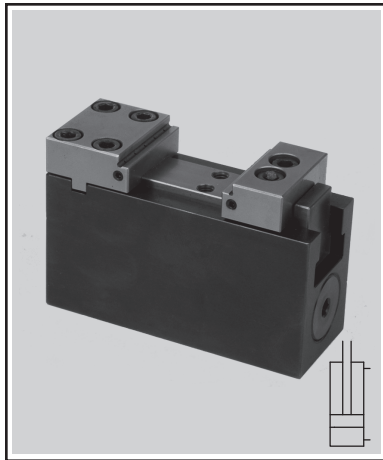

The fixed jaw fixture clamp consists of a very compact body with an integrated hydraulic cylinder that actuates the movable jaw. All threads and ports are at the bottom which allows for a very tight and space saving arrangement. If fastening from the bottom is not possible an adaptor plate for manifold

mounting or tube connection is available. Accessory blank jaws are also available that can be milled to match the workpiece contour. The fixed jaw can be equipped with a pneumatic seat control which is well suited for automation applications.

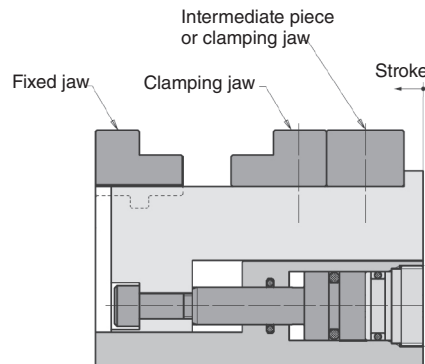

Blank jaws and cap screws sold separately.

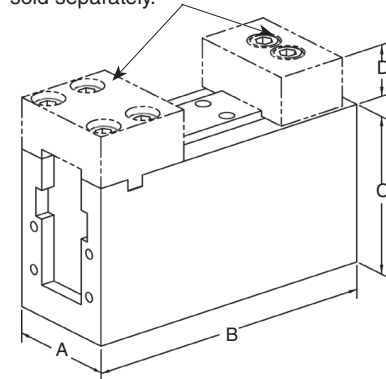

Fixing from above
with accessory adaptor plate
Drilled channels

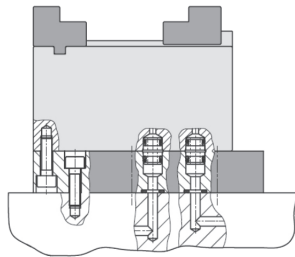

Application example
Clamping fixture for a pedal of a freight vehicle.

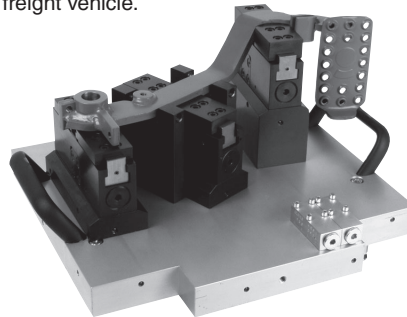

Fixing from below
Drilled channels

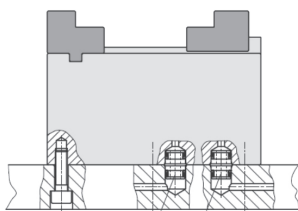

Connecting insert

Fitting connection

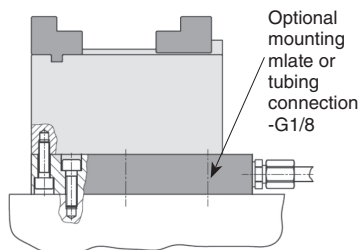

Optional mounting plate or tubing connection -G1/8

Jaw Width (in.)		1.57		2.56	
Stroke (in.)		0.20	1.18	0.20	1.77
Clamp Force (lbs)	3625 psi	2135	2135	3370	3370
	2000 psi	1180	1180	1860	1860
	1000 psi	600	600	930	930
A (in.)		1.57	1.57	2.56	2.56
B (in.)		4.13	6.10	6.30	9.45
C (in.)		2.17	2.17	2.56	2.56
D (in.)		0.71	0.71	1.06	1.06
Weight (lbs.)		3.66	4.94	11.13	15.43
Part No.		CLR-4413-001	CLR-4413-031	CLR-4413-101	CLR-4413-131

Accessories

Part No., Adapter Mounting Plate	CLR-0441-300	CLR-0441-303	CLR-0441-310	CLR-0441-313
Part No., Blank Clamping Jaw	CLR-3548-070	CLR-3548-070	CLR-3548-080	CLR-3548-080
Part No., Blank Fixed Jaw	CLR-3548-071	CLR-3548-071	CLR-3548-081	CLR-3548-081
Part No., Jaw Screws	CLR-3301-107	CLR-3301-107	CLR-3300-700	CLR-3300-700



Vises ■ Fixture Clamps ■ I4.120

Fixture Clamps, Concentric ■ Compact vise with jaw widths 1.57" and 2.56" Double Acting ■ Max. Operating Pressure ■ 3625 psi (250 bar)

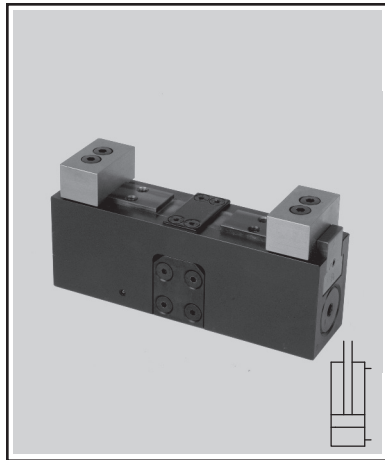

The concentric fixture clamp consists of a very compact body with two integrated hydraulic cylinders that actuate the movable jaws. The piston forces are transferred to a "V" linkage (see cut away below). The "V" linkage then pulls the jaws together in a self-centering fashion. All threads and ports are at the bottom

which allows for a very tight and space savings arrangement. If fastening from the bottom is not possible an adaptor plate for manifold mounting or tube connection is available. Accessory blank jaws are also available that can be milled to match the workpiece contour.

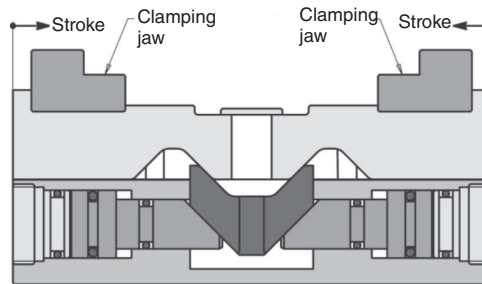

Fixing from above
with accessory adaptor plate
Drilled channels

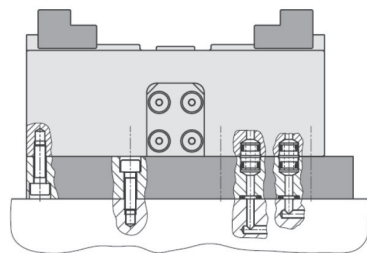

Application example
Clamping fixture for a pedal of a freight vehicle.

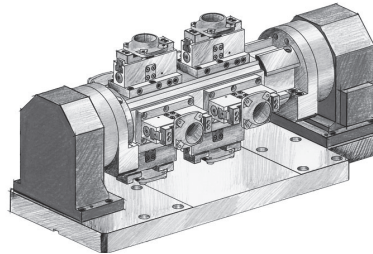

Blank jaws and cap screws sold separately.

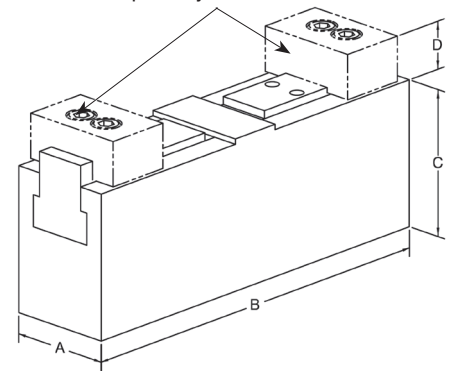

Fixing from below
Drilled channels

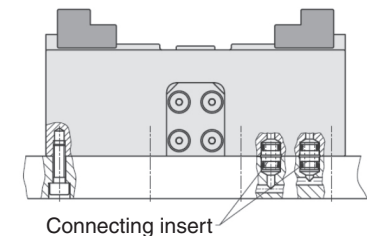

Connecting insert

Fitting connection

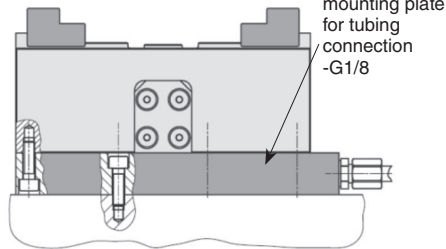

Optional mounting plate for tubing connection -G1/8

Jaw Width (in.)	1.57	2.56
Stroke per Jaw (in.)	0.20	0.31
Repeatability +/-	0.0008	0.0008
Clamp Force per Jaw (lbs)	3625 psi	1460
	2000 psi	805
	1000 psi	405
A (in.)	1.57	2.56
B (in.)	6.10	7.87
C (in.)	2.17	2.56
D (in.)	0.71	1.10
Weight (lbs.)	5.29	13.23
Part No.	CLR-4413-051	CLR-4413-151

Accessories

Part No., Adapter Mounting Plate	CLR-0441-305	CLR-0441-315
Part No., Blank Clamping Jaw	CLR-3548-070	CLR-3548-080
Part No., Jaw Screws	CLR-3301-107	CLR-3300-625

Subject to change. For further details, including detailed dimensions and mounting instructions, visit roemheld-usa.com.



ROEMHELD
HILMA ■ STARK

Carr Lane Roemheld Mfg. Co.
Sales — Phone (314) 647-6200 Fax (314) 647-5736
Engineering — Phone 1-800-827-2526 Web roemheld-usa.com

Vises ■ Fixture Clamps ■ 14.130

Fixture Clamps, Position Flexible ■ Compact vise with jaw width 1.57"
Double Acting ■ Max. Operating Pressure ■ 3625 psi (250 bar)

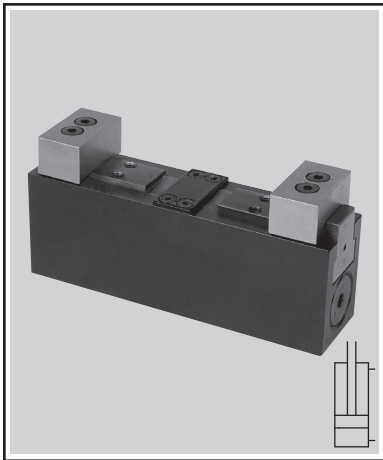

Fixing from above
with accessory adaptor plate
Drilled channels

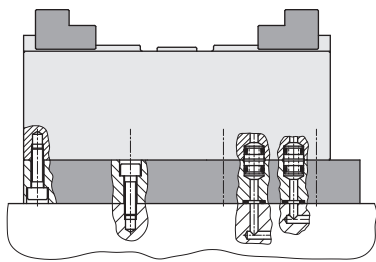

Fixing from below
Drilled channels

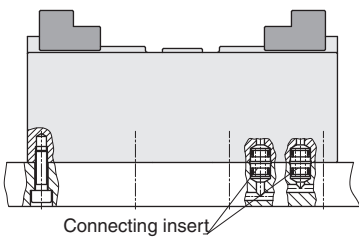

Pipe thread

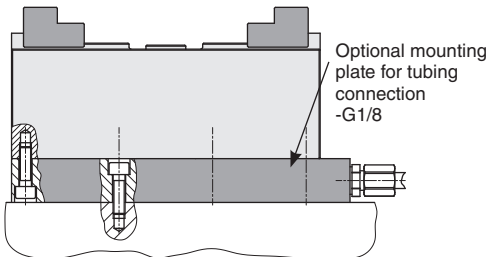

The position flexible fixture clamp consists of a very compact body with integrated hydraulic cylinders that actuate the movable jaws. The piston forces are transmitted via two channels to the clamping slides. The design allows the clamping slides to move independently of each. A minimal contact force is applied to the part until both jaws are in contact with the workpiece. At that point the pressure builds

along with the clamping force. All threads and ports are at the bottom which allows for a very tight and space savings arrangement. If fastening from the bottom is not possible an adaptor plate for manifold mounting or tube connection is available. Accessory blank jaws are also available that can be milled to match the workpiece contour.

Application example
Clamping fixture for a pedal of a freight vehicle.

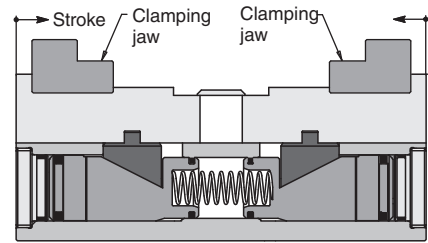
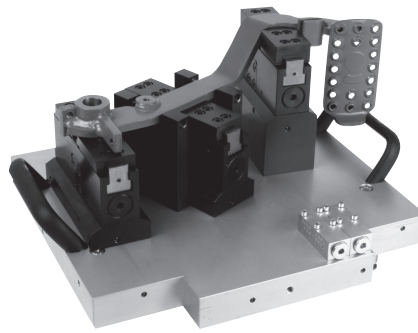

Blank jaws and cap screws sold separately.

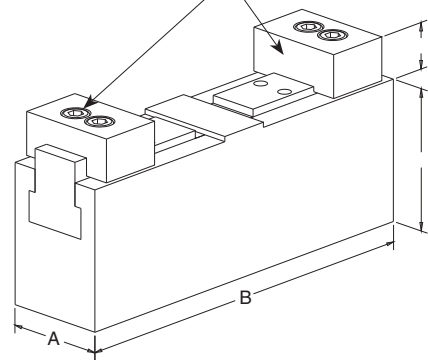

Clamping principle

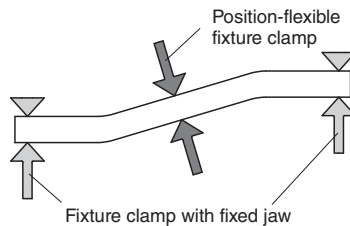

Jaw Width (in.)	1.57	
Stroke per Jaw (in.)	0.31	
Clamp Force per Jaw (lbs)	3625 psi	1800
	2000 psi	990
	1000 psi	495
A (in.)	1.57	
B (in.)	6.10	
C (in.)	2.17	
D (in.)	0.71	
Weight (lbs.)	5.51	
Part No.	CLR-4413-080	

Accessories	
Part No., Adapter Mounting Plate	CLR-0441-305
Part No., Blank Clamping Jaw	CLR-3548-070
Part No., Jaw Screws	CLR-3301-107

Subject to change. For further details, including detailed dimensions and mounting instructions, visit roemheld-usa.com.



ROEMHELD
HILMA ■ STARK

Carr Lane Roemheld Mfg. Co.

Sales — Phone (314) 647-6200 Fax (314) 647-5736

Engineering — Phone 1-800-827-2526 Web roemheld-usa.com

Power Sources

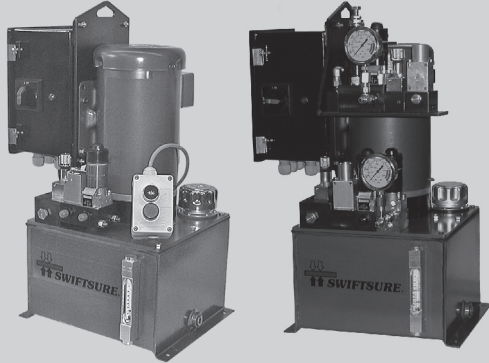

Electric Power Units
pages 667-670

Electric Power Units

Electric Power Units are the best power source for most uses. Complete, compact, quiet, and fully automatic. Include pump, reservoir, switches, valves, gauge, and numerous safety devices. Extremely long life. Enough fluid capacity for virtually any fixture. Up to 7250 psi output pressures. 120, 220, or 440 volt.

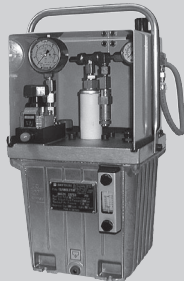

Air Power Units
pages 671-672

Air Power Units

Economical power source, driven by shop air pressure, includes pump, reservoir, valves, gauges, air filter, muffler, and air extractor/dryer. Very quiet. Ideal for hazardous locations. Enough fluid capacity for virtually any fixture. Up to 7250 psi output pressure.

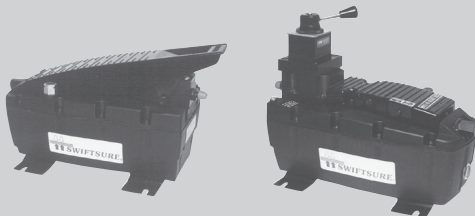

Compact Air Power Units
page 673

Compact Air Power Units are ideal for smaller hydraulic clamping and assembly fixtures with single or double-acting hydraulic elements. Ordinary shop air is all that is required to drive these units.



ROEMHELD
HILMA ■ STARK

Carr Lane Roemheld Mfg. Co.
Sales — Phone (314) 647-6200 Fax (314) 647-5736
Engineering — Phone 1-800-827-2526 Web roemheld-usa.com

Power Sources

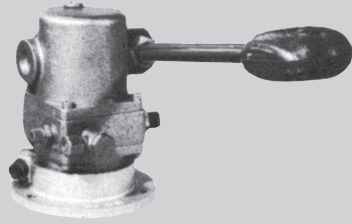

Single Stage Pump
pages 674

Hand Pumps

Manual power source for moderate-size factors. Compact and portable. Ideal for sensitive test fixtures. Choice of hand or foot operation.

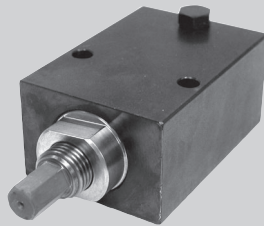

Screw Pumps
pages 675

Screw Pumps

Small enough to mount directly on fixture. Operate manually or with a power torque wrench. Ideal for rotary index tables and palletized fixtures where a feed line is impractical.

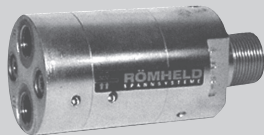

Compact Hydraulic Intensifier
pages 676-677

Hydraulic Intensifiers

Hydraulic Intensifiers convert hydraulic pressure on the input to a higher pressure on the output. This compact cylinder style intensifier enables the use of the comparatively low pressure of machine tool hydraulics to pressurize hydraulic clamping fixtures with a correspondingly increased input pressure.



Electric Power Units

7250/5000 psi max
Single and double acting

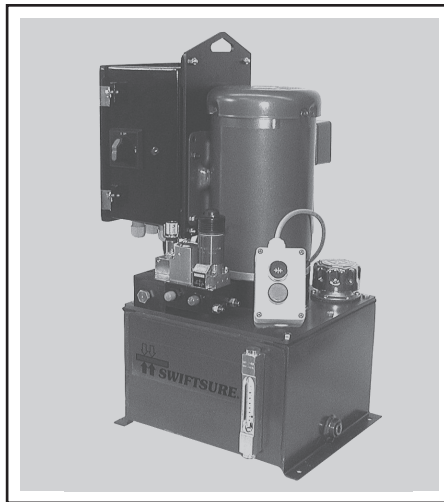

Standard

- Complete power unit with electrical and hydraulic controls
- Totally enclosed fan cooled single and three phase universal motors
- Thermal overload relay with automatic reset when normal conditions return
- Remote clamp-unclamp push button switch(s)
- Pressure adjustable from 1500 to maximum
- Quiet long life radial piston pump
- Filler breather with inlet screen
- Leak free fittings and poppet valves

SETUP AND OPERATION: Connect to fused electrical supply, fill with clean, approved hydraulic fluid and connect to fixture. Mount push button clamping switch near the operator (two furnished with shuttle machine units). Push one button to clamp and unclamp.

OPERATING PRINCIPLES: The heart of the unit is a precision, long-life radial-piston pump controlled upon pressure demand by the integral pressure switch. This switch is adjustable, to give you precise and repeatable clamping forces. Automatic pressure control is assured, because the pump restarts if pressure drops. Clamping pressure is assured even with an electrical power failure since the solenoid valves are mechanically held in the clamped position - and only need power to unclamp. The poppet design of these valves means positive, leakage-free sealing.

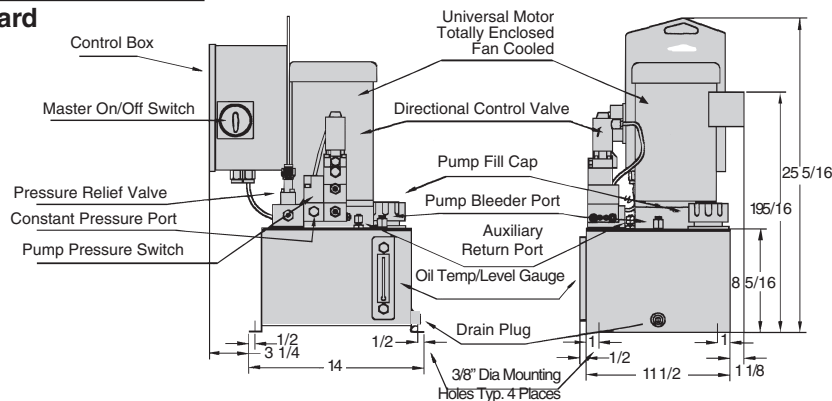

Adjustable Operating Pressure	1160-7250		725-5075		725-5075	
Power supply	460 volts 3 Phase 60Hz	230 volts 3 Phase 60Hz	230 volts 1 Phase 60Hz	115 volts 1 Phase 60Hz	460 volts 3 Phase 60Hz	230 volts 3 Phase 60Hz
Flow rate (cu.in/min)	66	66	66	66	106	106
Usable fluid capacity (cu.in)	400	400	400	400	400	400
Reservoir capacity (cu.in.)	690	690	690	690	690	690
Motor horsepower	1.5	1.5	1.0	1.0	1.5	1.5
Motor amperage	2.1	4.2	6.4	12.8	2.1	4.2
Noise level @ 3 ft. (dBA)	75	75	75	75	75	75
Max. uninterrupted running time (sec.)	15-120	15-120	15-120	15-120	15-120	15-120
Max. % of cycle pump should operate	25-40%	25-40%	25-40%	25-40%	25-40%	25-40%
Weight (lbs.)	110	110	110	110	110	110
Part No. Basic Pump (No Controls or Valves)	CLR-9301-EP	CLR-8301-EP	CLR-93011-EP	CLR-83011-EP	CLR-9302-EP	CLR-8302-EP
Part No. Single Acting System	CLR-931-EP	CLR-831-EP	CLR-9321-EP	CLR-8321-EP	CLR-932-EP	CLR-832-EP
Part No. Double Acting System	CLR-933-EP	CLR-833-EP	CLR-9341-EP	CLR-8341-EP	CLR-934-EP	CLR-834-EP
2 Independent S/A systems (shuttle machining)	CLR-935-EP	CLR-835-EP	CLR-9361-EP	CLR-8361-EP	CLR-936-EP	CLR-836-EP
2 Independent D/A systems (shuttle machining)	CLR-937-EP	CLR-837-EP	CLR-9381-EP	CLR-8381-EP	CLR-938-EP	CLR-838-EP
Manual Decoupling System Double Acting	CLR-939-EP	CLR-839-EP	CLR-9401-EP	CLR-8401-EP	CLR-940-EP	CLR-840-EP
Auto Decoupling System S/A Customer control	CLR-941-EP	CLR-841-EP	CLR-9421-EP	CLR-8421-EP	CLR-942-EP	CLR-842-EP
Auto Decoupling System D/A Customer control	CLR-943-EP	CLR-843-EP	CLR-9441-EP	CLR-8441-EP	CLR-944-EP	CLR-844-EP

All Pump Systems contain Controls and Valve packages ready to go. No add on packages required. Fluid Recommendations are in F&A section. SPECIALS AVAILABLE, CONSULT ENGINEERING 1-800-827-2526



ROEMHELD
HILMA ■ STARK

Carr Lane Roemheld Mfg. Co.
Sales — Phone (314) 647-6200 Fax (314) 647-5736
Engineering — Phone 1-800-827-2526 Web roemheld-usa.com

Electric Power Units

7250/5000 psi max
Multi-Pressure in single and double acting

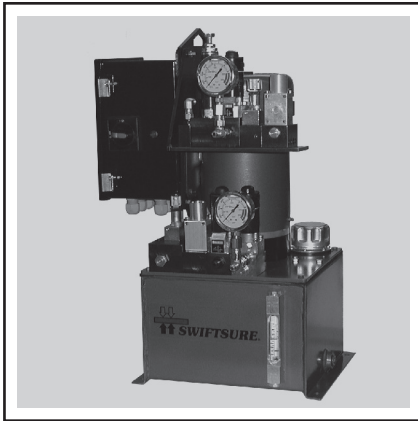

Multi-Pressure Pumps

- Complete power unit with electrical and hydraulic controls
- Enclosed fan-cooled single or three phase motor with thermal protection
- Combination temperature/ level switch for pump protection
- Remote clamp-unclamp push button switch(es)
- Pressure adjustable from minimum to maximum as shown in pump chart
- Quiet long life radial piston pump
- Filler breather with inlet screen
- Leak free fittings and poppet valves
- Additional pressure gauges provided for reduced pressure circuits

SET-UP SUMMARY: Connect to fused electrical supply, fill with oil, and connect to fixture. Prime pump and adjust to desired pressure. Mount push button switch(es) near the operator. Push one button to clamp and unclamp. For complete set-up instructions, see operating manual.

OPERATING PRINCIPLES: The heart of the unit is a precision, long-life radial-piston pump controlled upon pressure demand by the integral pressure switch. This switch is adjustable, to give you precise and repeatable clamping forces. The secondary pressure is controlled by a poppet style pressure reducing valve. This secondary low pressure circuit is adjustable between 450 and 5500 psi. Automatic pressure control is assured, because the pump restarts if pressure drops. Clamping pressure is assured even with an electrical power failure since the solenoid valves are mechanically held in the clamped position - and only need power to unclamp. The poppet design of these valves means positive, leakage-free sealing.

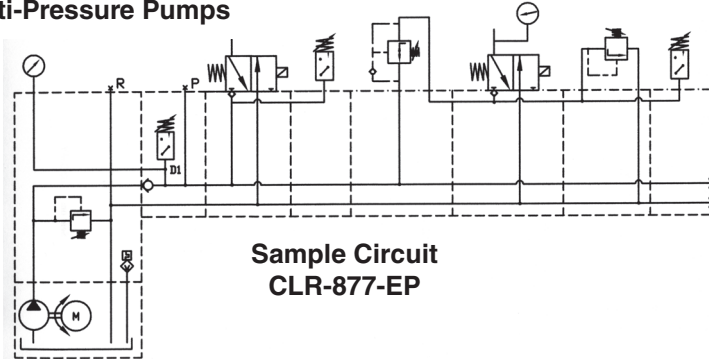

Sample Circuit
CLR-877-EP

Adjustable Operating Pressure	1160-7250 psi		725-5075 psi		725-5075 psi	
Power supply	460 volts 3 Phase 60Hz	230 volts 3 Phase 60Hz	230 volts 1 Phase 60Hz	115 volts 1 Phase 60Hz	460 volts 3 Phase 60Hz	230 volts 3 Phase 60Hz
Flow rate (cu.in./min.)	66	66	66	66	106	106
Usable fluid capacity (cu.in.)	400	400	400	400	400	400
Reservoir capacity (cu.in.)	690	690	690	690	690	690
Motor horsepower	1.5	1.5	1.0	1.0	1.5	1.5
Motor amperage	2.1	4.2	6.4	12.8	2.1	4.2
Nose level @ 3ft. (dBA)	75	75	75	75	75	75
Max. uninterrupted running time (sec.)	15-120	15-120	15-120	15-120	15-120	15-120
Max. % of cycle pump should operate	25-40%	25-40%	25-40%	25-40%	25-40%	25-40%
Two S/A Circuits, One Reduced W/One Pendent	CLR-951-EP	CLR-851-EP	CLR-9521-EP	CLR-8521-EP	CLR-952-EP	CLR-852-EP
Two D/A Circuits, One Reduced W/One Pendent	CLR-953-EP	CLR-853-EP	CLR-9541-EP	CLR-8541-EP	CLR-954-EP	CLR-854-EP
Two S/A Circuits, One Reduced W/Two Pendants	CLR-955-EP	CLR-855-EP	CLR-9561-EP	CLR-8561-EP	CLR-956-EP	CLR-856-EP
Two D/A Circuits, One Reduced W/Two Pendants	CLR-957-EP	CLR-857-EP	CLR-9581-EP	CLR-8581-EP	CLR-958-EP	CLR-858-EP
Two S/A Circuits, One Reduced W/One Pendent & Two Pressure Switches	CLR-959-EP	CLR-859-EP	CLR-9601-EP	CLR-8601-EP	CLR-960-EP	CLR-860-EP
Two D/A Circuits, One Reduced W/One Pendent & Two Pressure Switches	CLR-971-EP	CLR-871-EP	CLR-9721-EP	CLR-8721-EP	CLR-972-EP	CLR-872-EP
Two S/A Circuits, One Reduced W/Two Pendants & Two Pressure Switches	CLR-973-EP	CLR-873-EP	CLR-9741-EP	CLR-8741-EP	CLR-974-EP	CLR-874-EP
Two D/A Circuits, One Reduced W/Two Pendants & Two Pressure Switches	CLR-975-EP	CLR-875-EP	CLR-9761-EP	CLR-8761-EP	CLR-976-EP	CLR-876-EP
Two S/A Circuits, One Reduced W/One Pendent, Two Pressure Switches & One Pressure Relief Valve	CLR-977-EP	CLR-877-EP	CLR-9781-EP	CLR-8781-EP	CLR-978-EP	CLR-878-EP
Two D/A Circuits, One Reduced W/One Pendent, Two Pressure Switches & One Pressure Relief Valve	CLR-979-EP	CLR-879-EP	CLR-9801-EP	CLR-8801-EP	CLR-980-EP	CLR-880-EP
Two S/A Circuits, One Reduced W/Two Pendants, Two Pressure Switches & One Pressure Relief Valve	CLR-981-EP	CLR-881-EP	CLR-9821-EP	CLR-8821-EP	CLR-982-EP	CLR-882-EP
Two D/A Circuits, One Reduced W/Two Pendants, Two Pressure Switches & One Pressure Relief Valve	CLR-983-EP	CLR-883-EP	CLR-9841-EP	CLR-8841-EP	CLR-984-EP	CLR-884-EP

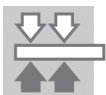

ROEMHELD
HILMA ■ STARK

Carr Lane Roemheld Mfg. Co.

Sales — Phone (314) 647-6200 Fax (314) 647-5736
Engineering — Phone 1-800-827-2526 Web roemheld-usa.com

Electric Power Units

7250/5000 psi max
Single and double acting

CONTROL OPTIONS: Electric Power Units are offered with three standard hydraulic/ electrical-control options: (1) Single acting, (2) Double acting, (3) Single acting for two independent fixtures.

The following hydraulic-circuit diagram shows a single-acting unit.

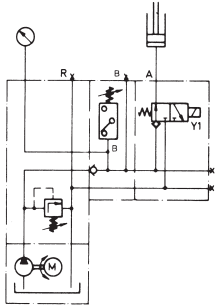

The diagram below shows a double-acting unit. Double-acting units can be used as single acting units simply by capping the return pressure connection, with a CLR-501-F cap fitting.

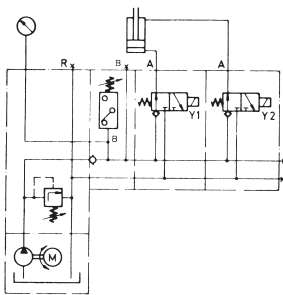

The third diagram shows a single-acting unit for two independent fixtures (shuttle machining). These units have separate clamping switches and valves for each fixture.

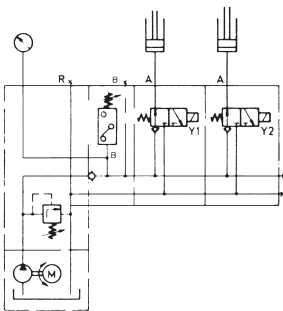

SAFETY FEATURES: Fail-safe operation in case of electrical-power failure since the solenoid-operated clamping valves are de-energized in "clamped" position. These valves are poppet type, so they provide tight zero leakage sealing. Units are also equipped with fluid-level and fluid-temperature sensors to protect power units from abuse. If fluid level drops below a minimum level or fluid temperature exceeds 140° F, the unit shuts off and lights an LED. When fluid is replenished or temperature drops, the unit resets itself automatically.

MOUNTING: Mount unit upright, preferably above fixture level to keep unit clean. We offer an attractive, economical power-unit stand (below) that bolts to the floor. For mounting directly on machine-tool tables, we offer a vibration-proof mount (also below).

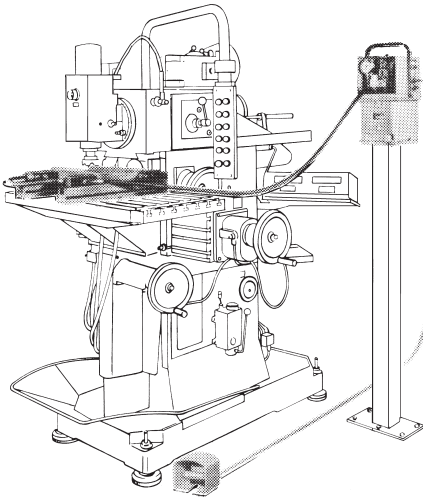

Power Unit Stand
CLR-3532-168-PUA

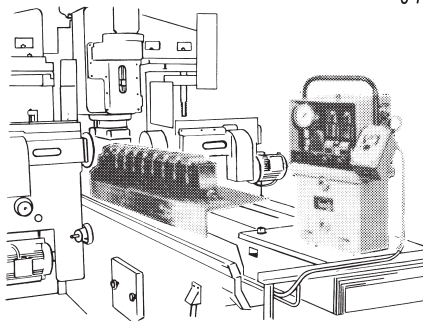
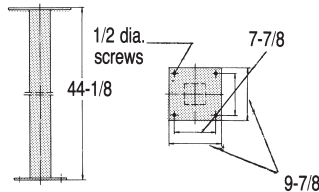

Vibration-proof mount
CLR-3141-308-PUA

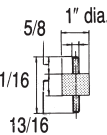

Units can also be mounted on the machine tool using an angle bracket. The photo below shows an overhead traverse bar for convenient hose arrangement. Push-button switches are installed within the operator's reach.

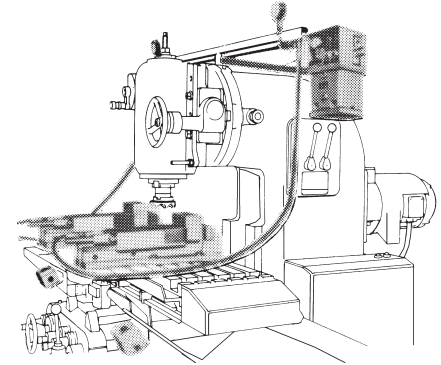

PRESSURE SETTING: Set system pressure by adjusting the setting screw (5) on the unit's pressure switch (4) in combination with the knurled knob (3) on the unit's pressure-relief valve (1). Basically, the pressure switch establishes the minimum system pressure (10% drop below setting) and the pressure-relief valve establishes the maximum in case of over pressurization.

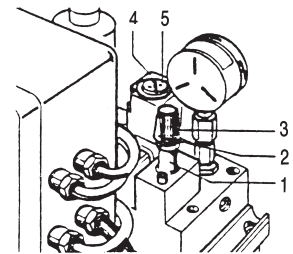

DUTY CYCLE: Electric Power Units are designed specifically and purely for workholding, with intermittent clamping and unclamping between machining cycles (not continuous running). For most workholding applications, actual running time is a small percentage of total cycle time. The graph below shows typical pump-pressure buildup during a machining cycle.

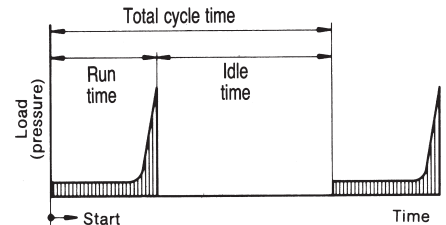

Run time must be less than 40% of total cycle time with maximum fluid level, 25% with minimum fluid level (7250-psi units). Run time must also be less than 120 seconds with maximum fluid level, 15 seconds with minimum fluid level (7250-psi units). Otherwise the fluid will overheat and the unit will shut off automatically.



Electric Power Units

Connection Examples

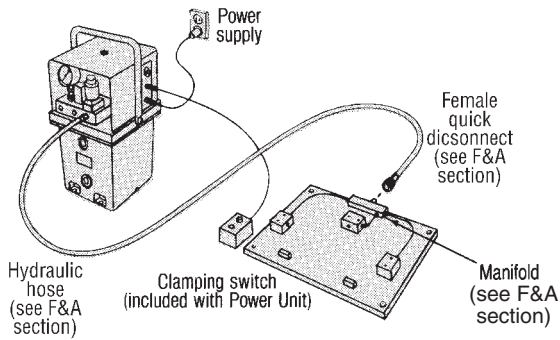

**Single Fixture
Single Acting**
(use any Electric Power Unit)

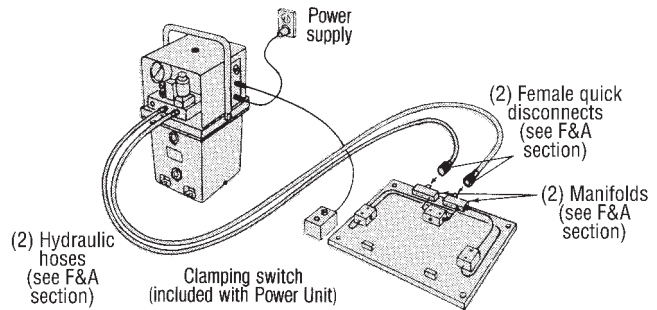

**Single Fixture
Double Acting**
(use CLR-933-EP or CLR-833-EP)

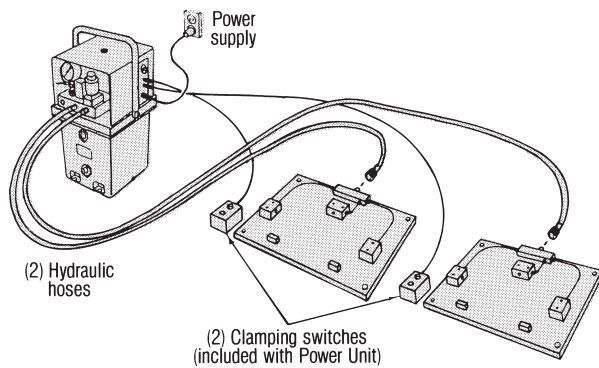

**Two Fixtures
Single Acting**
(use CLR-935-EP or CLR-835-EP)

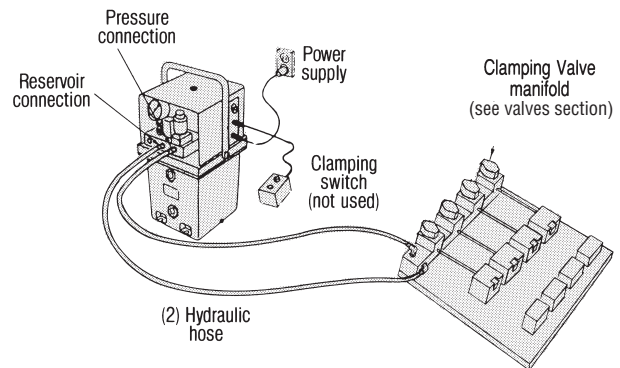

**Multiple Parts Clamped Independently
Single Acting or Double Acting**
(use any Electric Power Unit)



Air Power Units

7250 psi max
Single and double acting



- Economical and self-contained. . . just fill with fluid
- Up to 7250 psi from shop air pressure (only 70-psi air pressure required)
- Tandem, reciprocating pump automatically restarts to maintain system pressure
- Holds pressure even if air supply fails
- Safe in hazardous locations
- Complete turnkey unit includes clamping valve, filter/regulator/lubricator, air and hydraulic pressure gauges, muffler, and air extractor/dryer

** Do not use NPT fittings

OPERATION: Unit is ready to run after you fill the reservoir with fluid (order separately, F&A section) and connect it to an air supply. Adjust the input air pressure, using the unit's air regulator, to adjust output fluid pressure (2200 to 7250-psi range). Only 70-psi air pressure is required to provide 7250-psi fluid pressure.

FLOW CONTROL: When using these power units in small circuits containing a Swing Clamp, Extending Clamp, or fluid-advanced Work Support, a simple flow control valve may be necessary. If clamps do not cycle properly, install flow control valve anywhere along the fluid lines to control flow to any or all workholding components.

Control Option 1
Single acting.
Clamp/unclamp valve mounted on power unit.

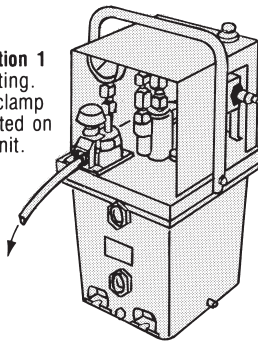

Control Option 2
Single acting.
Remote control.
Includes 10-ft air hoses and air valve.

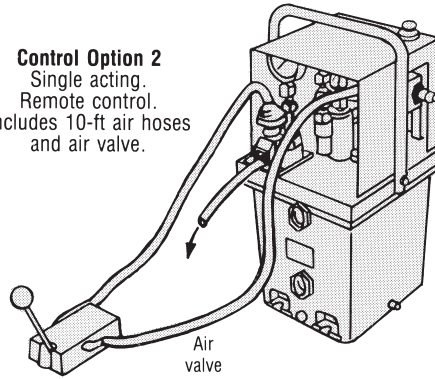

Control Option 3
Double acting.
Remote control.
Includes 4-way valve and two 6-ft hydraulic hoses (other lengths available).

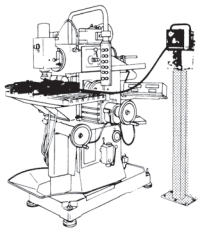
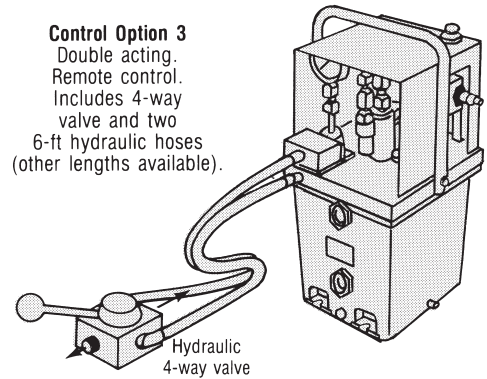

Power Unit Stand
CLR-3532-168-PUA
available upon request

Input Air Pressure (psi)	Output Fluid Pressure (psi)											
	Free flow		1500		3000		4500		6000		7250	
	Flow Rate cu. in./min.	Input Air Vol. CFM	Flow Rate cu. in./min.	Input Air Vol. CFM	Flow Rate cu. in./min.	Input Air Vol. CFM	Flow Rate cu. in./min.	Input Air Vol. CFM	Flow Rate cu. in./min.	Input Air Vol. CFM	Flow Rate cu. in./min.	Input Air Vol. CFM
30	74	23	46	14	8	4	—	—	—	—	—	—
40	82	29	62	22	35	13	—	—	—	—	—	—
50	88	37	69	30	50	20	24	10	—	—	—	—
60	91	43	75	36	60	28	38	18	8	5	—	—
70 and higher	94	48	80	42	68	35	50	27	27	15	5	3

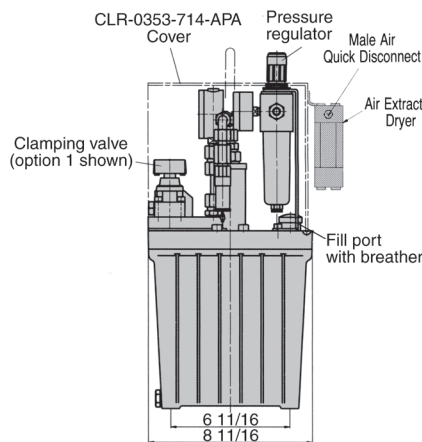
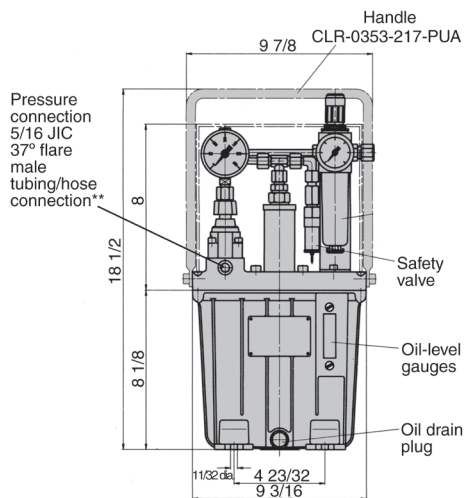

Operating pressure range	2350-7250 psi
Intensification Ratio	108:1
Flow Rate (cu. in./min.)	see table
Min. input air pressure (psi)	14.5
Usable fluid capacity (cu. in.)	150
Reservoir capacity (cu. in.)	260
Noise level at 3 ft. (dBA)	76
Weight (lbs)	50
Part No. Control option 1	CLR-100-AP
Part No. Control option 2	CLR-102-AP
Part No. Control option 3	CLR-105-AP
Part No. Pump without valves	CLR-106-AP

Fluid Recommendations see F&A section.



ROEMHELD
HILMA ■ STARK

Carr Lane Roemheld Mfg. Co.
Sales — Phone (314) 647-6200 Fax (314) 647-5736
Engineering — Phone 1-800-827-2526 Web roemheld-usa.com

Connection Examples

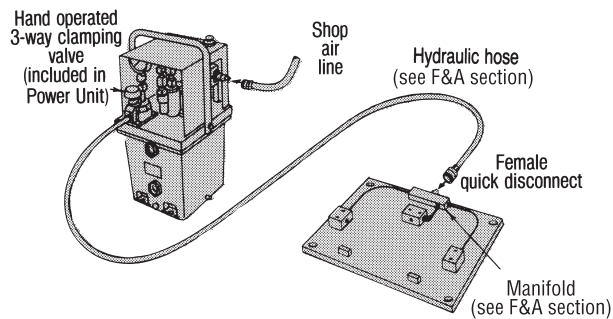

Single Fixture
Valve mounted on unit
Single Acting
CLR-100-AP

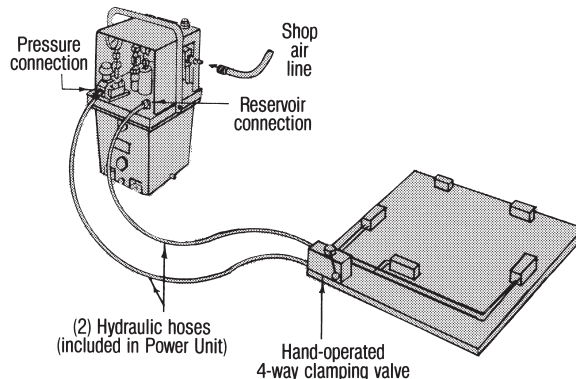

Single Fixture
Double Acting
CLR-103-AP

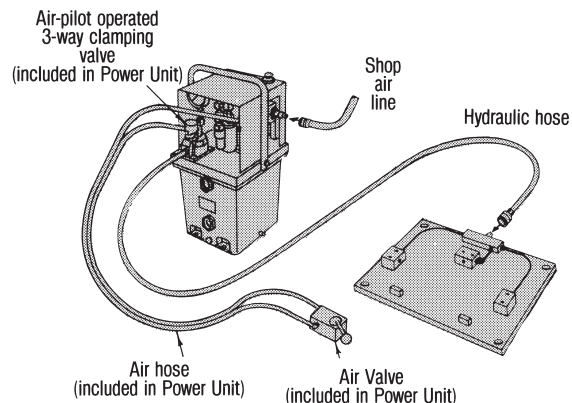

Single Fixture
Remote Valve
Single Acting
CLR-102-AP

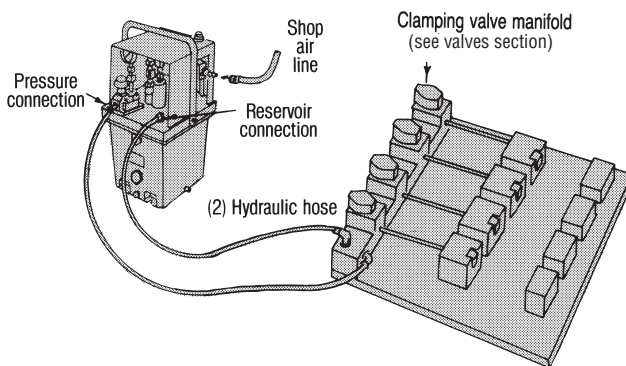

Multiple Parts Clamped Independently
Single Acting or Double Acting
(Use any Air Power Unit)

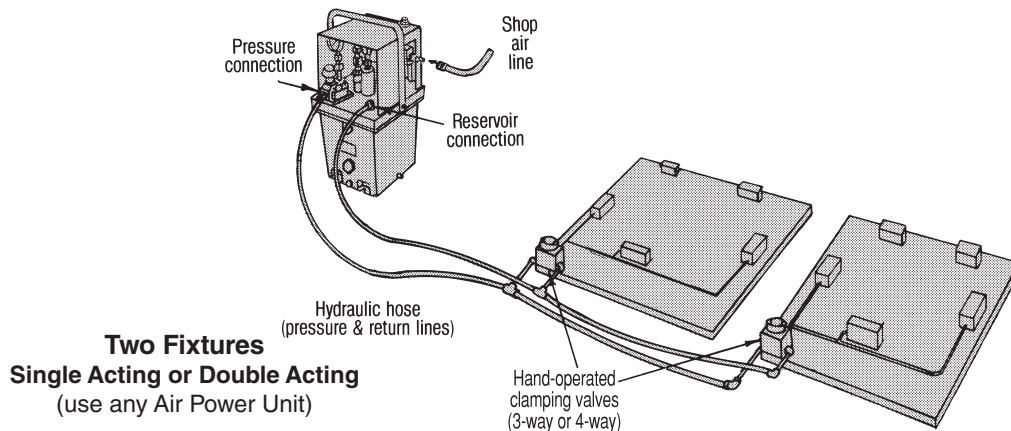

Two Fixtures
Single Acting or Double Acting
(use any Air Power Unit)



Air Power Units

7250 psi max
Single/double acting

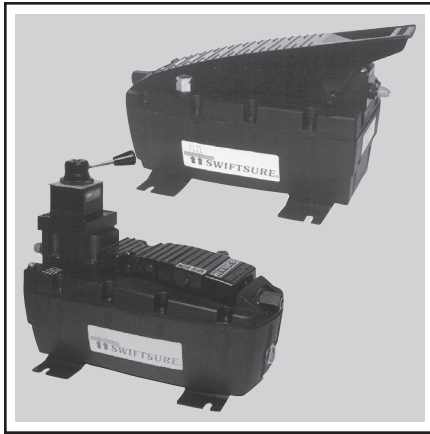

- The hydro-pneumatic pump unit can be operated with oil-free air.
- Due to suitable sound insulation only minimum working noises are obtained.
- The low starting pressure (40 psi) guarantees a quick start of the pump and short cycle time.
- The hydro-pneumatic pump unit is delivered ready for connection

APPLICATION: The hydro-pneumatic pump unit is particularly suitable for smaller hydraulic clamping and assembly fixtures with single or double-acting hydraulic elements. As the power supplied is compressed air, it can be used without restriction in hazardous surroundings.

OPERATION: Single acting version The single-acting hydro-pneumatic pump unit is manually operated. By operating the pedal the fixture will be clamped or unclamped. The pump delivers oil as long as necessary to achieve the desired hydraulic operating pressure. The air pressure is adjusted by a pneumatic service unit and maintained by an integrated check valve.

Double acting version By means of a locking device the pneumatic directional control valve (at the pneumatic side) is permanently in the opened switching position. By means of the mounted hand-operated hydraulic 4/3 directional control valve double-acting cylinders can be controlled. In the case of a pressure loss, the pneumatic pump operates automatically until the desired hydraulic pressure is realized.

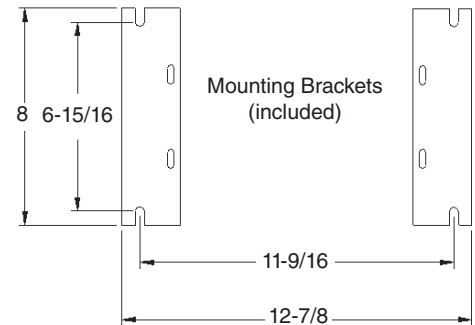
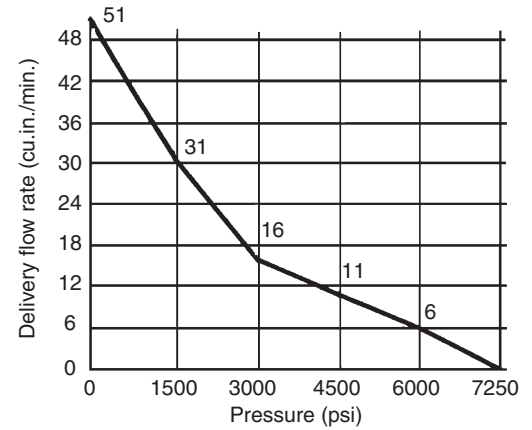
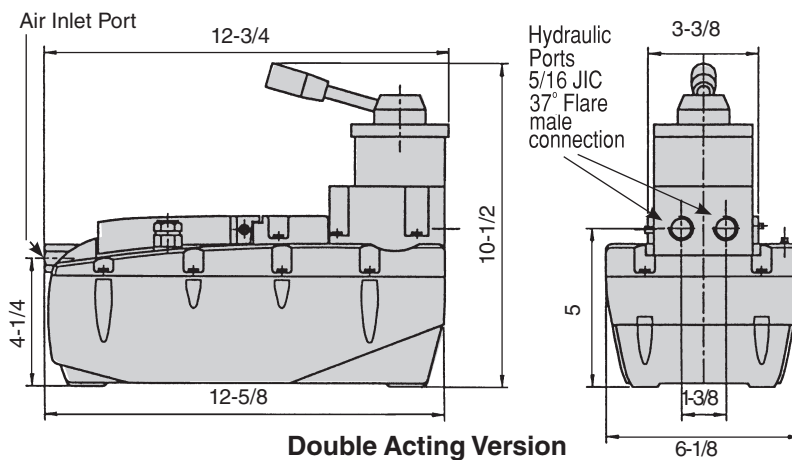
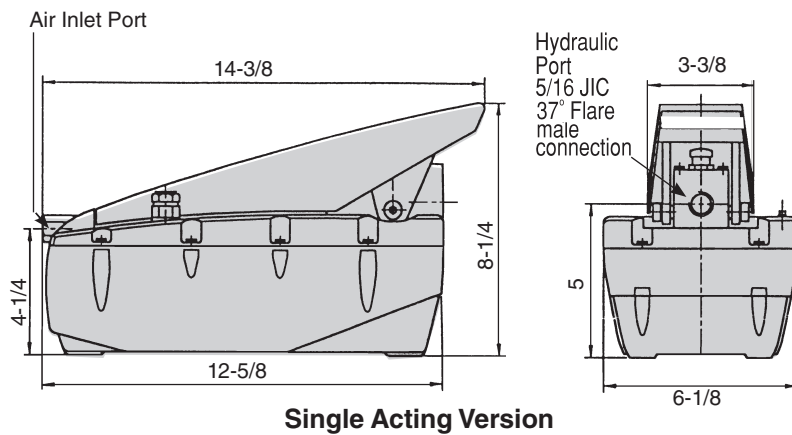

Operating Pressure Range	4000-7250 psi
Intensification Ratio	100:1
Flow Rate (cu.in./min.)	see graph
Min. input air pressure (psi)	40
Usable fluid capacity (cu.in.) Horiz/Vert	125/90
Reservoir capacity (cu.in.) Horiz/Vert	150/135
Connecting Threads	
• Oil	G 1/4 BSPP
• Air	1/4 NPT
Weight (lbs)	14
Part No., single acting	CLR-200-AP
Part No., double acting	CLR-203-AP
Part No., pump only - no valves	CLR-201-AP

Fluid Recommendations see F&A section.



ROEMHELD
HILMA ■ STARK

Carr Lane Roemheld Mfg. Co.

Sales — Phone (314) 647-6200 Fax (314) 647-5736
Engineering — Phone 1-800-827-2526 Web roemheld-usa.com

Hand Pumps

7250/3000 psi max
Single acting



Single Stage

- Very compact
 - Pump and release with the same lever
 - Easily adjustable pressure setting
 - Choice of hand or foot operation
- ** Do not use NPT fittings

CLAMPING: Move pump lever downward to pump fluid, through a 40-degree stroke. Lever returns upward by spring force. Repeat until you reach the set pressure and the lever declutches.

UNCLAMPING: Lift pump lever 10 degrees upward against spring force to release clamping force instantly.

CONSTRUCTION: Totally self-contained power source. Virtually wearfree due to metallic seal on pump piston.

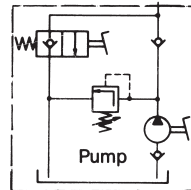

Symbol

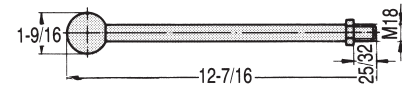

Hand Lever
CLR-003-HPA

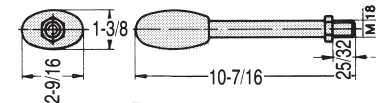

Foot Lever
CLR-002-HPA

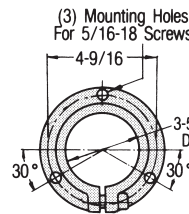
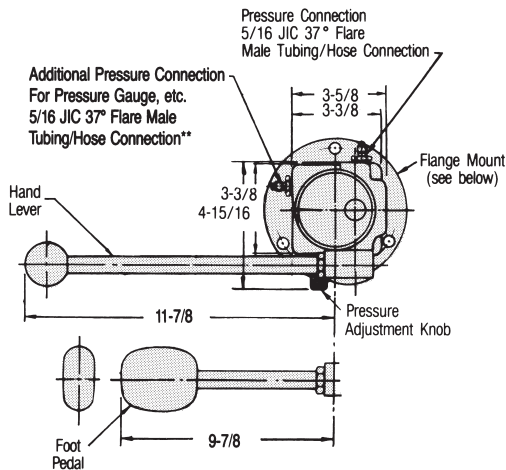
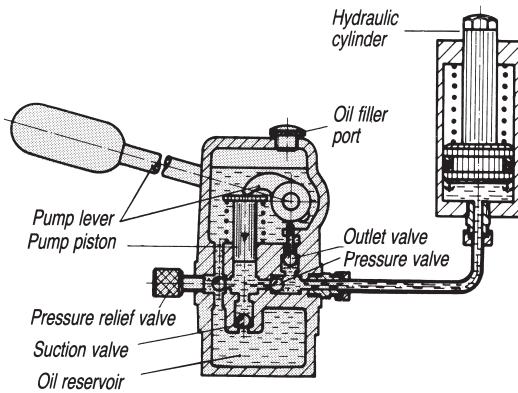

Flange
CLR-303-HPA

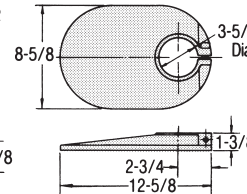

Weighted
Base
CLR-301-HPA

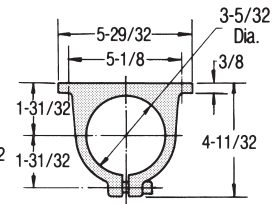

Bracket
CLR-302-HPA

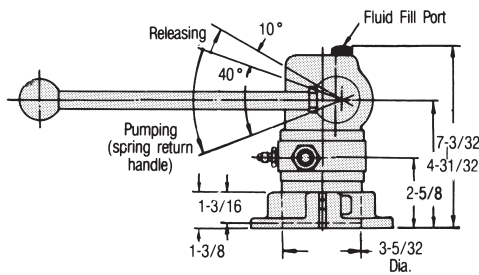

Operating Pressure Range	0-7250 psi	0-3000 psi
Displacement per stroke (cu.in.)	.12	.24
Usable oil volume (cu.in.)	9	9
Reservoir capacity (cu.in.)	18	18
Relief valve adjustment range (psi)	150-7250	150-3000
Weight (lbs)	16-27	16-27
Part No. with flange and hand lever	CLR-601-HP	CLR-401-HP
with flange and foot lever	CLR-602-HP	CLR-402-HP
Part No. with base and hand lever	CLR-603-HP	CLR-403-HP
with base and foot lever	CLR-604-HP	CLR-404-HP
Part No. with bracket and hand lever	CLR-605-HP	CLR-405-HP
with bracket and foot lever	CLR-606-HP	CLR-406-HP
Part No., pump only	CLR-600-HP	CLR-400-HP

Fluid Recommendations see F&A section.



Carr Lane Roemheld Mfg. Co.
Sales — Phone (314) 647-6200 Fax (314) 647-5736
Engineering — Phone 1-800-827-2526 Web roemheld-usa.com

Screw Pumps

7250 psi max
Single acting



Compact Block



Cartridge/Manifold Mounted

- Compact pressure source
- Ideal for rotary tables or pallets where fluids supply lines are impractical
- Excellent for holding pressure while fixture is transferred
- Can be used in multiples for more fluid capacity
- May be operated with a power torque wrench (non-impact)
- 7250 psi pressure from 38 ft-lbs torque
- ** Do not use NPT fittings

DESIGN CONSIDERATIONS:

1. Include a pressure gauge in the system (see F&A section).
2. All clamps and components must be leak free, so use only Roemheld products.
3. Since fluid capacity is limited, use only on small fixtures. For best results, clamps should use only 65% of total fluid capacity. Due to limited capacity, use only with smallest accumulator CLR-9606-102-PDA.
4. Systems must be bled carefully and designed to avoid air pockets. Include a separate fill plug on the cartridge mounted version, at the highest point in the system.
5. Mount block-type Screw Pump only horizontally with fluid fill port up.
6. For safety on palletized fixtures, use a control cylinder (F&A section) with a position sensor on the machine.

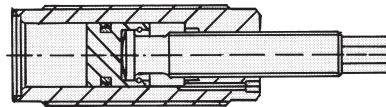
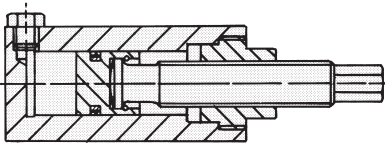

Within this diameter range, the port drilling should be located as high up as possible

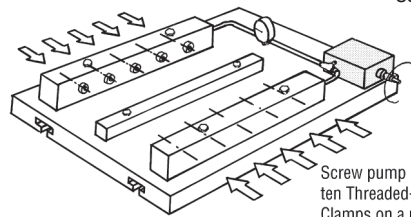
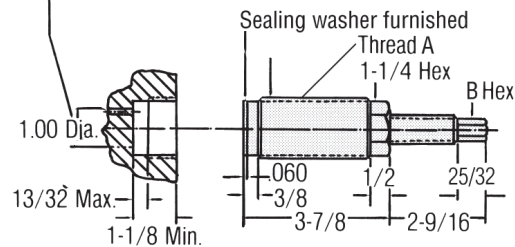

Hole Preparation for manifold mounting

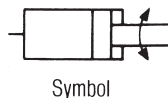
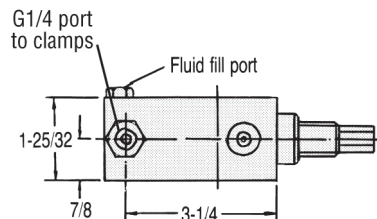
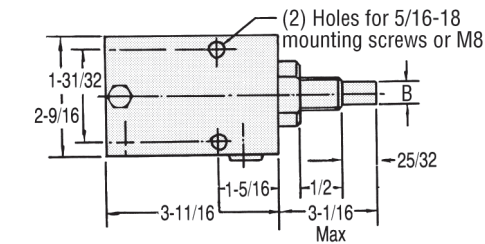

Operating Pressure Range	0-7250 psi
Total fluid capacity (cu. in.)	1.28
Fluid displacement per revolution (cu. in.)	.06
Installation torque, manifold mounting (ft. lbs.)	58
Weight (lbs)	4.0

Inch

A body thread	1-1/2- 16
B Hex	1/2
Part No., compact block	CLR-900-SP
Part No., manifold mounted	CLR-901-SP
Part No., sealing washer	CLR-3000-843-SW

Metric

A body thread	M38 x 1.5
B Hex	SW 13
Part No., compact block	CLR-8819-001-SP
Part No., manifold mounted	CLR-8819-101-SP
Part No., sealing washer	CLR-3000-843-SW



Carr Lane Roemheld Mfg. Co.

Sales — Phone (314) 647-6200 Fax (314) 647-5736
Engineering — Phone 1-800-827-2526 Web roemheld-usa.com

Hydraulic Intensifier

7250 psi max



APPLICATION: The hydraulic intensifier converts a hydraulic pressure on the primary side (input) into a higher pressure on the secondary side (output).

This enables the use of the comparatively low pressure of machine tool hydraulics to pressurize a hydraulic cylinder with a correspondingly increased intensification ratio.

DESCRIPTION: The construction of the hydraulic intensifier corresponds to the principle of pressurizing areas of different sizes. Regulation of the high pressure at the secondary side is made by regulation of the low pressure side and is directly proportional.

First the intensifier delivers a high flow

rate at a low pressure (displacement of the cylinders), with increasing counterpressure the intensifier switches automatically to pressure intensification. For unclamping, the cylinder is directly controlled with the low-pressure of the primary side (see example below).

FUNCTION: the oil is supplied through input **IN** via the check valves **RV1**, **RV2**, and **DV** to the high pressure output **H** and thereby to the cylinders. In this phase the intensifier is in rapid function. According to the intensification **i** the max. flow rate can be up to 10 liters/min. With increasing pressure in the cylinder the oscillating pump unit **OP** (pulsation) automatically functions. If the adjusted high-pressure is obtained, pulsation of the intensifier is stopped. Pulsation continues in case of dynamic application. Max. frequency of pulsation is 30 Hz.

To retract the cylinder, the internal check valve **DV** is controlled via port **R** and thereby free return through the intensifier is guaranteed.

IMPORTANT NOTES: The hydraulic oil must be perfectly filtered with particles not larger than nominally 10 micron. This is the reason why we offer a filter unit (part no. CLR-3887-087), which can be directly integrated in the tubing of the low-pressure side. If the intensifier will be used on uncoupled systems (no connection to the pressure generator) a pilot-controlled check valve should be mounted at the high-pressure side (consider min. control pressure for opening). For pilot-operated check valve, see valves section.

When designing an installation, pay attention that there can be leakage between the ports **IN** and **R** of the high-pressure intensifier.

Leakage rate approx. 50 cm³/min. When using the intensifier in uncoupled systems there will be a pressure increase in the unclamping line due to the leakage. — Please contact us.

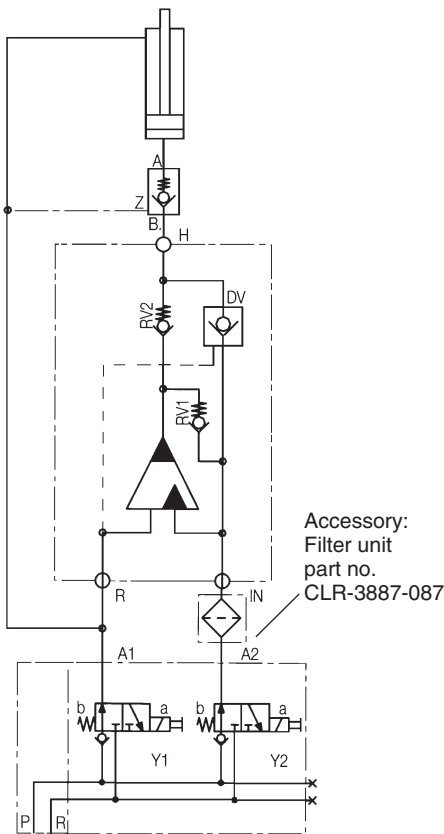
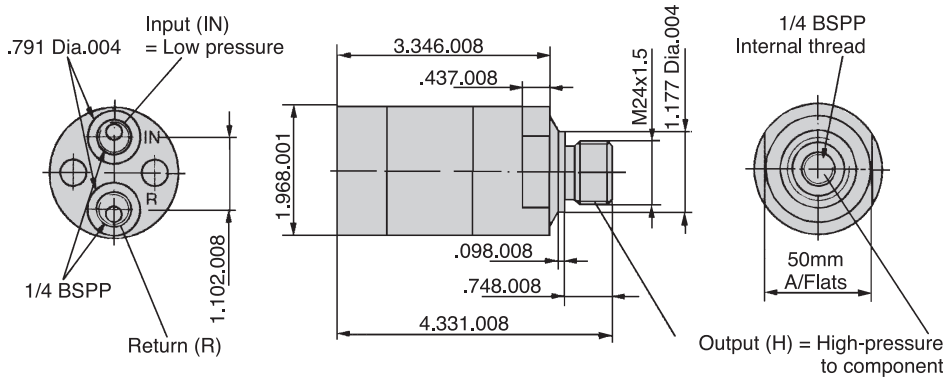

Intensification Ratio	1.5	2.0	3.2	4.0	5.0
Max. flow rate Low-pressure side Q _{IN} (cu.in)	488	488	915	854	854
Max. flow rate, High-pressure side Q _H (cu.in)	61	48	150	120	98
Max. operating pressure Low-pressure side P _{IN} psi	3000	3000	2000	1800	1500
Max. operating pressure High-pressure side P _H psi	4500	6000	7250	7250	7250
Weight (lbs)	2	2	2	2	2
Part No.	CLR-8755-015	CLR-8755-020	CLR-8755-032	CLR-8755-040	CLR-8755-050



Carr Lane Roemheld Mfg. Co.

Sales — Phone (314) 647-6200 Fax (314) 647-5736

Engineering — Phone 1-800-827-2526 Web roemheld-usa.com

Hydraulic Intensifier

7250 psi max



APPLICATION: The hydraulic intensifier converts a hydraulic pressure on the primary side (input) into a higher pressure on the secondary side (output).

This enables the use of the comparatively low pressure of machine tool hydraulics to pressurize a hydraulic cylinder with a correspondingly increased intensification ratio.

DESCRIPTION: The construction of the hydraulic intensifier corresponds to the principle of pressurizing areas of different sizes. Regulation of the high pressure at the secondary side is made by regulation of the low pressure side and is directly proportional.

First the intensifier delivers a high flow rate at a low pressure (displacement of the cylinders), with increasing counterpressure the intensifier switches automatically to pressure intensification. For unclamping, the cylinder is directly controlled with the low-pressure of the primary side (see example on previous page).

FUNCTION: the oil is supplied through input **IN** via the check valves **RV1**, **RV2**, and **DV** to the high pressure output **H** and thereby to the cylinders. In this phase the intensifier is in rapid function. According to the intensification i the max. flow rate can be up to 10 liters/min. With increasing pressure in the cylinder the oscillating pump unit **OP** (pulsation) automatically functions. If the adjusted

high-pressure is obtained, pulsation of the intensifier is stopped. Pulsation continues in case of dynamic application. Max. frequency of pulsation is 30 Hz.

To retract the cylinder, the internal check valve **DV** is controlled via port **R** and thereby free return through the intensifier is guaranteed.

IMPORTANT NOTES: The hydraulic oil must be perfectly filtered with particles not larger than nominally 10 micron. This is the reason why we offer a filter unit (part no. CLR-3887-087), which can be directly integrated in the tubing of the low-pressure side. If the intensifier will be used on uncoupled systems (no connection to the pressure generator) a pilot-controlled check valve should be mounted at the high-pressure side (consider min. control pressure for opening). For pilot-operated check valve, see valves section.

When designing an installation, pay attention that there can be leakage between the ports **IN** and **R** of the high-pressure intensifier.

Leakage rate approx. 50 cm³/min. When using the intensifier in uncoupled systems there will be a pressure increase in the unclamping line due to the leakage. — Please contact us.

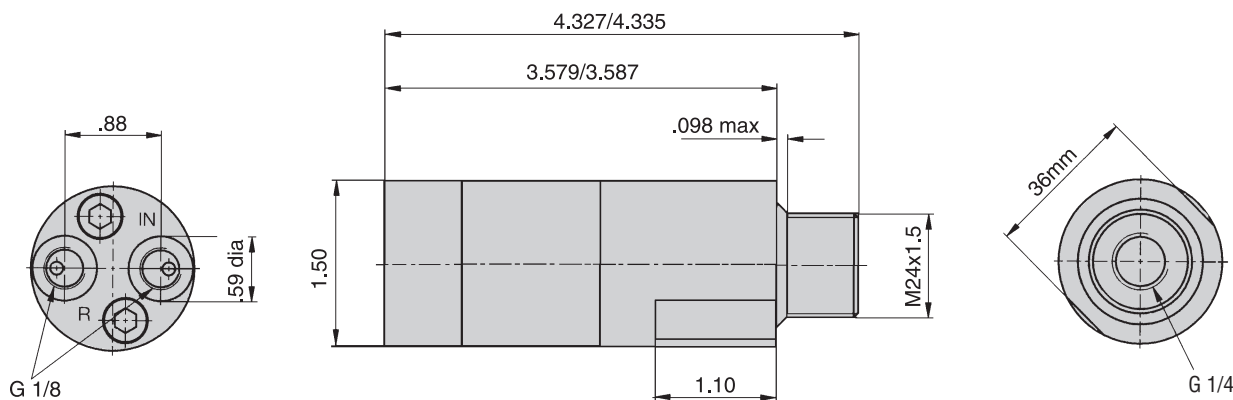

Intensification Ratio	3.2	4.0	4.8	6.2	7.5
Max. flow rate Low-pressure side QIN (cu.in)	490	490	490	490	490
Max. flow rate, High-pressure side QH (cu.in)	25	25	25	25	25
Max. operating pressure Low-pressure side PIN psi	2250	1800	1500	1100	950
Max. operating pressure High-pressure side PH psi	7250	7250	7250	7250	7250
Weight (lbs)	2.2	2.2	2.2	2.2	2.2
Part No.	CLR-8755-132	CLR-8755-140	CLR-8755-148	CLR-8755-162	CLR-8755-175



ROEMHELD
HILMA ■ STARK

Carr Lane Roemheld Mfg. Co.

Sales — Phone (314) 647-6200 Fax (314) 647-5736

Engineering — Phone 1-800-827-2526 Web roemheld-usa.com

Valves

Clamping Valves



**Hand-Operated
Single Acting**



**Hand-Operated
Double Acting**

For clamping several workpieces from a single power source.

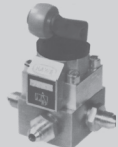

**Cam Roller
Single Acting**



**Air/Hydraulic Pilot
Single Acting**

page 680



**DC Solenoid
Single or Double Acting**

page 681

Extremely compact, for clamping several workpieces from a single power source.

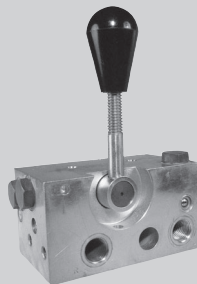









Heavy Duty Clamping Valve

Poppet style 4-way clamping valve can be used for single acting or double acting. Great for clamping several workpieces independently with a single power source. Heavy duty for extra-long life.

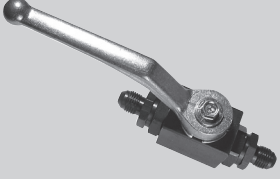

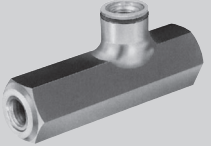
Valves

Control Valves	
Sequence Valves	
 <p>Manifold Mounted Or Series Mounted pages 684-685</p>	<p>For automatic sequencing of locating, clamping, and supporting operations. Easily adjustable trigger pressure. Use in multiples for multi-step sequencing.</p>
Pressure Control	
 <p>Pressure Closing page 683</p>	 <p>Pressure Reducing page 686</p>
 <p>Pressure Relief page 688</p>	
<p>Shut Off</p>  <p>Use to hold pressure in a fixture during machining. page 688</p>	<p>Flow Control</p>  <p>Use to restrict flow in one direction while allowing free return flow. page 689</p>
Check Valves	
 <p>Pilot-Operated Check valve that permits only one-way flow until released by a pilot fluid line. Available inline or manifold mounted. page 687</p>	 <p>Inline, Cartridge Type Allows fluid to flow in only one direction. page 689</p>



ROEMHELD
HILMA ■ STARK

Carr Lane Roemheld Mfg. Co.
Sales — Phone (314) 647-6200 Fax (314) 647-5736
Engineering — Phone 1-800-827-2526 Web roemheld-usa.com

Clamping Valves

7250 psi max
Single or double acting

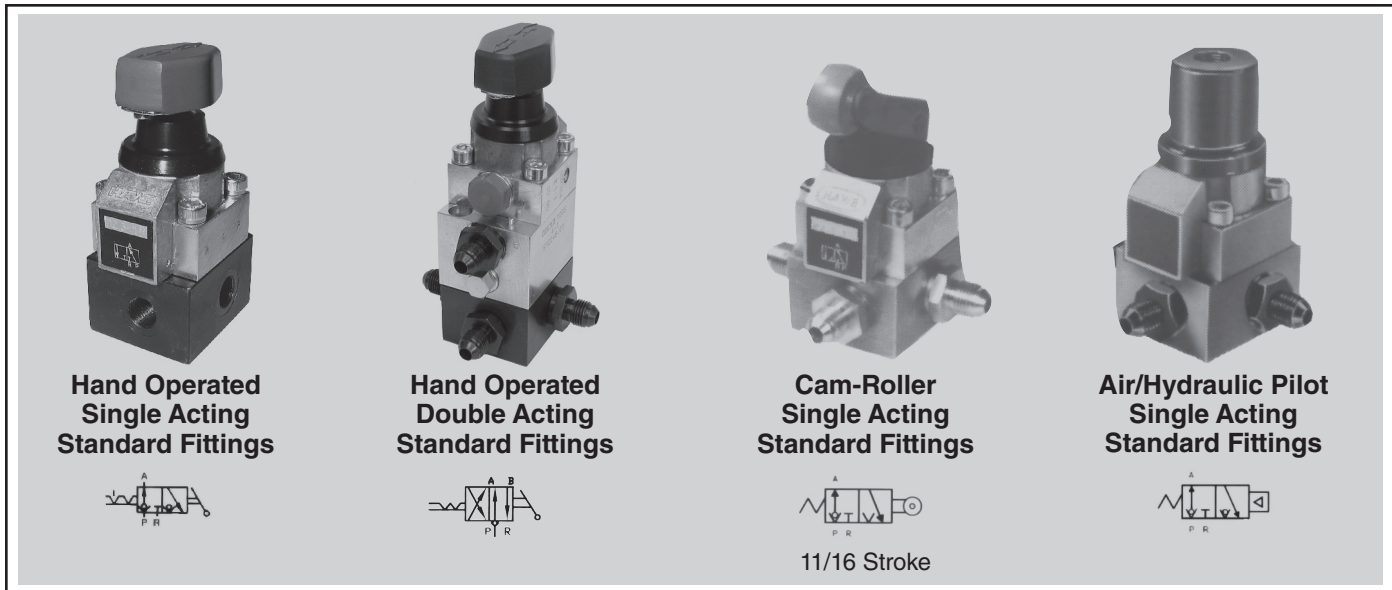

DOUBLE ACTING UNITS

SINGLE ACTING UNITS

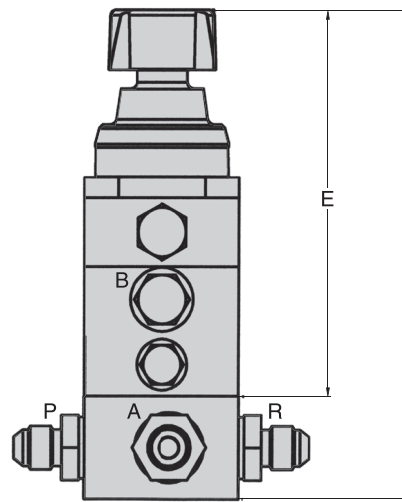
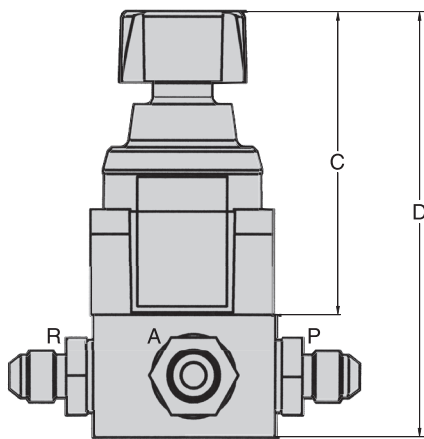

DOUBLE ACTING - STANDARD FITTINGS MOUNTING HOLE PATTERN

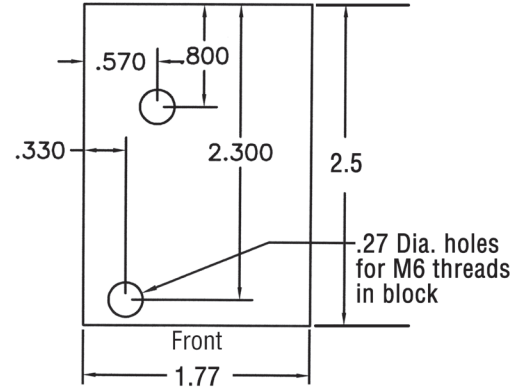

SINGLE ACTING - STANDARD FITTINGS MOUNTING HOLE PATTERN

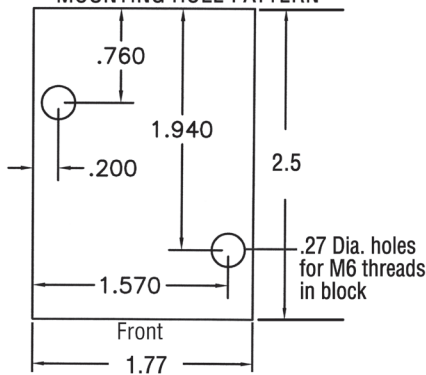

Type	Hand Operated	Cam Operated	Air Pilot	Hydraulic Pilot	24V DC Solenoid
C	4.13	4.34	2.81	2.81	5.63
D	5.63	5.84	4.31	4.31	7.13
E	5.51	5.72	4.19	4.19	7.01
F	7.01	7.22	5.69	5.69	8.51
Single Acting Standard Fittings	CLR-225-V	CLR-415-V	CLR-335-V	CLR-345-V	CLR-645-V
Single Acting Manifold Mount	CLR-219-V	CLR-411-V	CLR-319-V	CLR-325-V	CLR-629-V
Double Acting Standard Fittings	CLR-4220-V	CLR-4412-V	CLR-4320-V	CLR-4326-V	CLR-4630-V
Double Acting Manifold Mount	CLR-4219-V	CLR-4411-V	CLR-4319-V	CLR-4325-V	CLR-4629-V



ROEMHELD
HILMA ■ STARK

Carr Lane Roemheld Mfg. Co.

Sales — Phone (314) 647-6200 Fax (314) 647-5736

Engineering — Phone 1-800-827-2526 Web roemheld-usa.com

Clamping Valves

7250 psi max
Single or double acting



- Use to clamp several workpieces independently with a single power source
- For single-acting or double-acting clamps
- Zero-leakage poppet design with built-in check valve
- Extremely compact
- All electrical coils are continuous duty rated
- ** Do not use NPT fittings

Poppet Valves Spool Valves

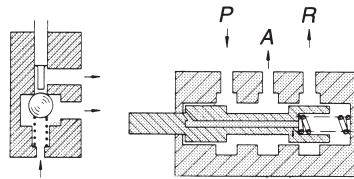

Only Roemheld offers all zero-leakage poppet valves. Others use spool valves, which always have internal leakage due to clearance between the bore and spool.

DESIGN CONSIDERATIONS: Port connections and flow directions must be exactly as shown on the drawings. Otherwise the valves will not function correctly.

P - Pressure into valve from power

R - Return from valve to power source

A - Flow from valve to clamps and back

Use these valves only with the fluid types we recommend, CLR-2-FL equivalent on **INFO+** page 722). Fluid must be clean (10 micron or better nominal filtration).

SOLENOID OPERATED: Clamp and unclamp automatically using electrical signals from a machine-tool controller. Operate clamps all at once, or individually using one valve per clamp. Stays clamped even if electric power fails, since solenoid is de-energized in the clamped position. 24 Volts DC (+5/-10% allowable voltage deviation). 2000 cycles/hour maximum. 20 watts power consumption. 120, 220, and 440 volt AC valve also available.

DOUBLE ACTING UNITS

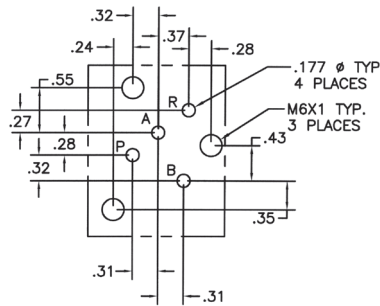
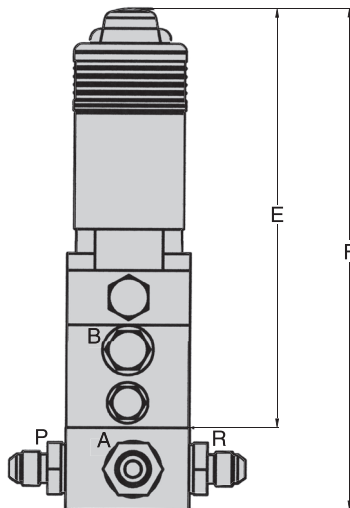

Double Acting

Mounting-hole pattern for manifold mounting. Grind surface flat, 32 Ra max. Order valves without base.

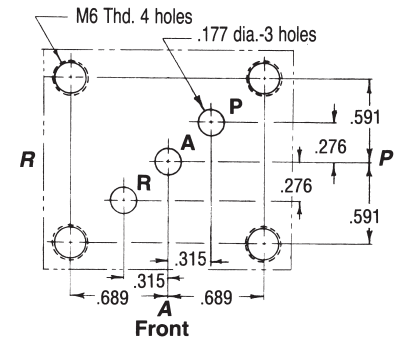

Single Acting

Standard DC Solenoid Valve

Type	Solenoid operated
Max. operating pressure (psi)	7250
Max. inrush draw (watts)	20
Max. flow rate (cu. in./min.)	490
Voltage (+5%/-10%)	24 VDC
Make time (milliseconds)	100
Break time (milliseconds)	50
Max. cycles per hour	2000
Weight (lbs)	1.5
Part No., Single Acting	CLR-645-V
Part No., Double Acting	CLR-4630-V

Part no.	Type	Normal position (no signal)	Check valve	Symbol
CLR-4630-V	4-way 2-position	N/A	Yes	
CLR-645-V	3-way 2-position	Open	Yes	
CLR-32361-200-V			No	
CLR-32362-300-V		Closed	Yes	
CLR-32362-200-V			No	
CLR-32361-301-V	2-way 2-position	Closed	No	
CLR-32361-302-V		Open	No	



ROEMHELD
HILMA ■ STARK

Carr Lane Roemheld Mfg. Co.
Sales — Phone (314) 647-6200 Fax (314) 647-5736
Engineering — Phone 1-800-827-2526 Web roemheld-usa.com

Clamping Valves (4-Way)

7250 psi max
Single and double acting



- Use to clamp several work pieces independently with a single power source
- For double-acting clamps
- Zero-leakage double-poppet design
- ** Do not use NPT fittings

Heavy-duty for extra-long life. Unique double-poppet design for zero leakage. To use with single-acting clamps, use Port Plug CLR-810-F on Port B. Internal check valves ensure fail-safe clamping.

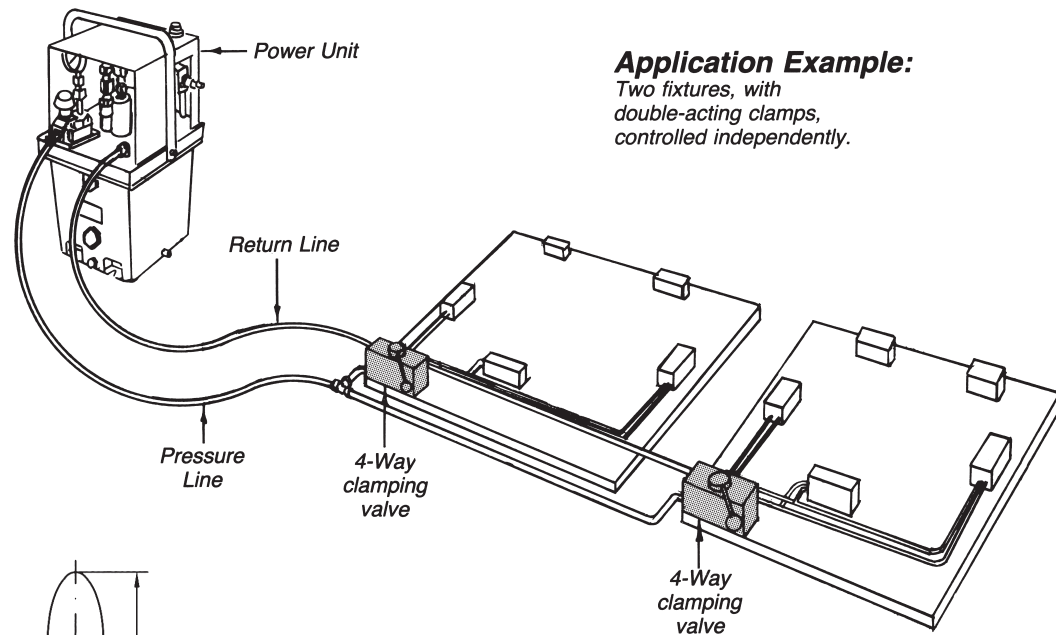

Application Example:

Two fixtures, with double-acting clamps, controlled independently.

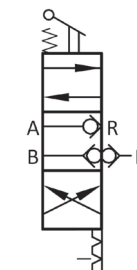
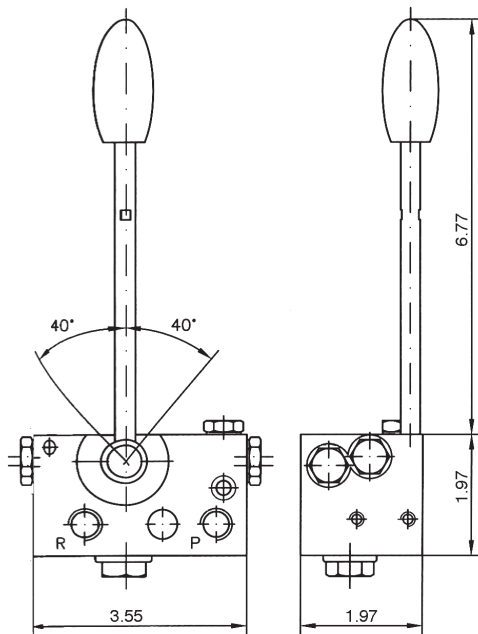

Max. Oper. Pressure (psi)	7250
Max. Flow Rate (cu. in./min.)	730
Direction of Flow	See Drawing
Port Size	G1/4
Weight (lbs)	2.5
Part No.	CLR-302-V



Carr Lane Roemheld Mfg. Co.

Sales — Phone (314) 647-6200 Fax (314) 647-5736
Engineering — Phone 1-800-827-2526 Web roemheld-usa.com

Pressure-Controlled Closing Valves

7250 psi max

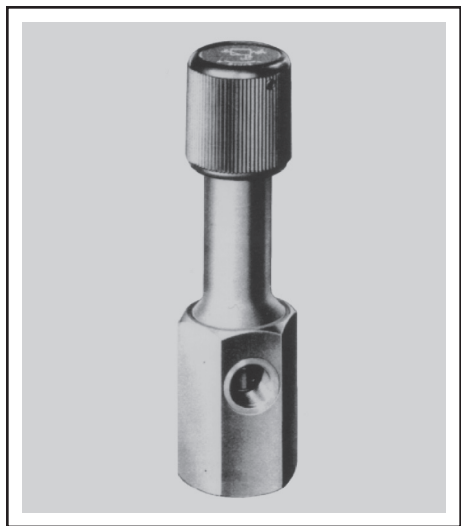

- Allows different operating pressures in two parts of a fixture
- Can be used on pallet fixtures disconnected from a power source, since no return line is needed
- Allows fine tuning the clamping force of selected components while keeping others constant
- Holds reduced pressure to exact setting, regardless of input pressure
- Zero-leakage poppet design

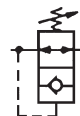

Symbol

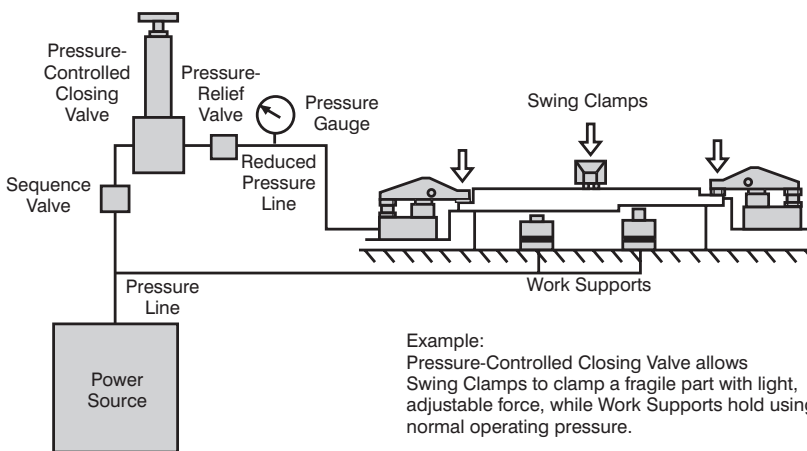
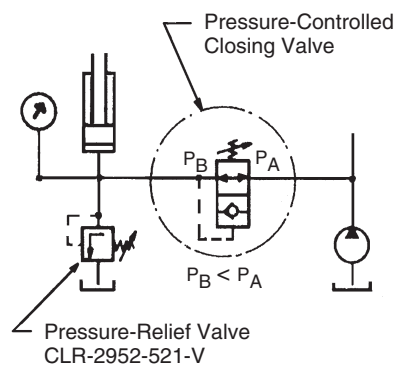
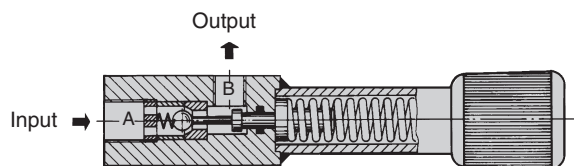

Example:
Pressure-Controlled Closing Valve allows Swing Clamps to clamp a fragile part with light, adjustable force, while Work Supports hold using normal operating pressure.

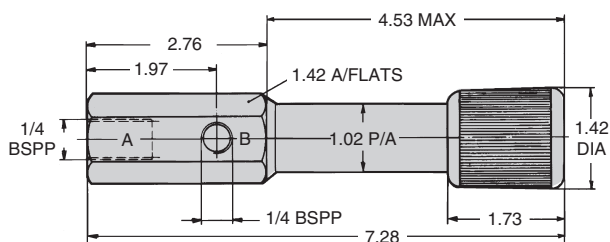

Reduced-pressure adjustment range (psi)	High	Medium	Low
		2900-7250	870-3190
Max. operating pressure, input (psi)	7250	7250	7250
Repeatability (+/- psi)	150	150	150
Max. fluid flow rate (cu. in./min.)	730	730	730
Part No.	CLR-2953-002-V	CLR-2953-003-V	CLR-2953-001-V



Carr Lane Roemheld Mfg. Co.

Sales — Phone (314) 647-6200 Fax (314) 647-5736

Engineering — Phone 1-800-827-2526 Web roemheld-usa.com

Sequence Valves

7250 psi max



- Use to automatically sequence positioning, clamping, and supporting

- Easily adjustable trigger pressure

- Use in multiples for multi-step sequencing

** Do not use NPT fittings

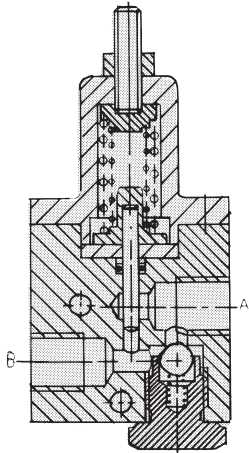
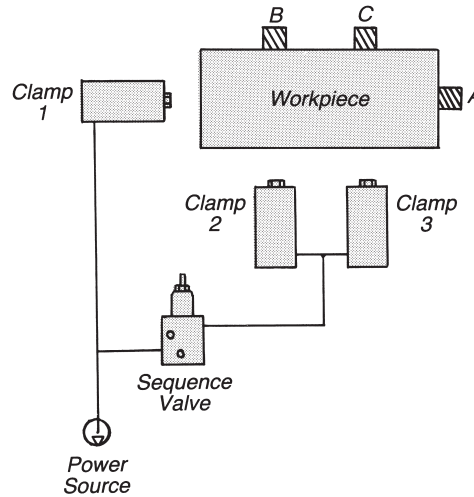

DESIGN CONSIDERATIONS: Choose normal pressure-adjustment-range valves instead of low-range valves whenever possible. Normal range models offer a wider adjustment range, especially when used with an Air Power Unit. For multi-stage sequencing, set trigger pressures in steps of at least 750 psi (normal range) or 375 psi (low range).

STANDARD FITTINGS: Mount in line. Fasten with two #10 cap screws if desired.

MANIFOLD MOUNTING: Fluid enters and exits through two O-ring ports fed by drilled fixture passages. Mount on a ground surface (32 Ra max.) using three #10 cap screws.

SERIES MOUNTING: Use one input valve and up to five series valves. Only one pressure connection is required, to the input valves P port. The other valves are connected by an internal passage, sealed with an O-ring between each valve. All required plugs, O-rings, and nuts are furnished.

Example clamping sequence:

Workpiece to be positioned and clamped sequentially. Sequence valve set for 1500 psi trigger pressure.

1. When clamps are actuated, clamp 1 pushes workpiece against stop A.
2. As soon as pressure reaches 1500 psi, sequence valve opens.
3. Clamps 2 and 3 simultaneously push workpiece against stops B and C.
4. Fluid pressure rises uniformly in all clamps.

Trigger pressure adjustment range (psi)	Low Range	Normal Range
		150 to 2200
Max. operating pressure (psi)	7250	7250
Pressure change per turn (psi)	220	440
Maximum flow	490 cu. in./min.	490 cu. in./min.
A Dia.	7/8	1-3/32
B	4-5/16	5-3/4
Weight (lbs)	1.1	1.4

Standard Fittings

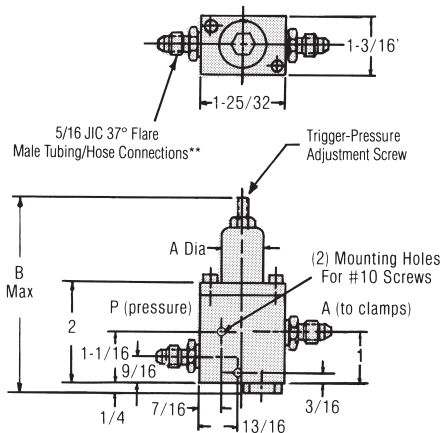

Standard Fittings

Part No.	CLR-420-V	CLR-440-V
----------	-----------	-----------

Manifold Mounted

Part No.	CLR-429-V	CLR-449-V
Part No., Spare O-Ring	CLR-3000-342-SW	CLR-3000-342-SW

Series Mounted

Part No., Input Valve	CLR-2954-427-V	CLR-2954-441-V
Part No., Series Valve	CLR-2954-428-V	CLR-2954-442-V
Part No., Connecting Bolt, 2 Valves	CLR-3619-029-VA	CLR-3619-029-VA
Part No., Connecting Bolt, 3 Valves	CLR-3619-031-VA	CLR-3619-031-VA
Part No., Connecting Bolt, 4 Valves	CLR-3619-032-VA	CLR-3619-032-VA
Part No., Connecting Bolt, 5 Valves	CLR-3619-033-VA	CLR-3619-033-VA
Part No., Connecting Bolt, 6 Valves	CLR-3619-034-VA	CLR-3619-034-VA



Carr Lane Roemheld Mfg. Co.

Sales — Phone (314) 647-6200 Fax (314) 647-5736

Engineering — Phone 1-800-827-2526 Web roemheld-usa.com

Sequence Valves

7250 psi max

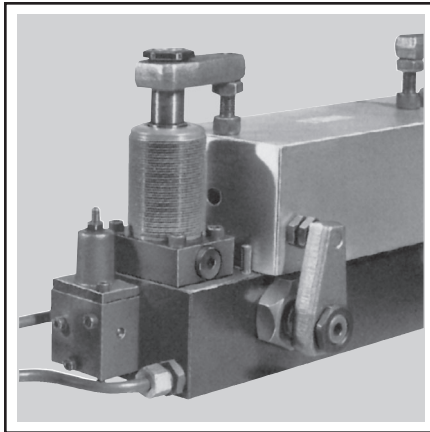

Manifold Mounted

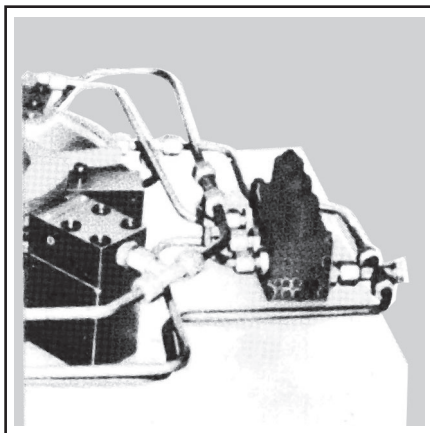
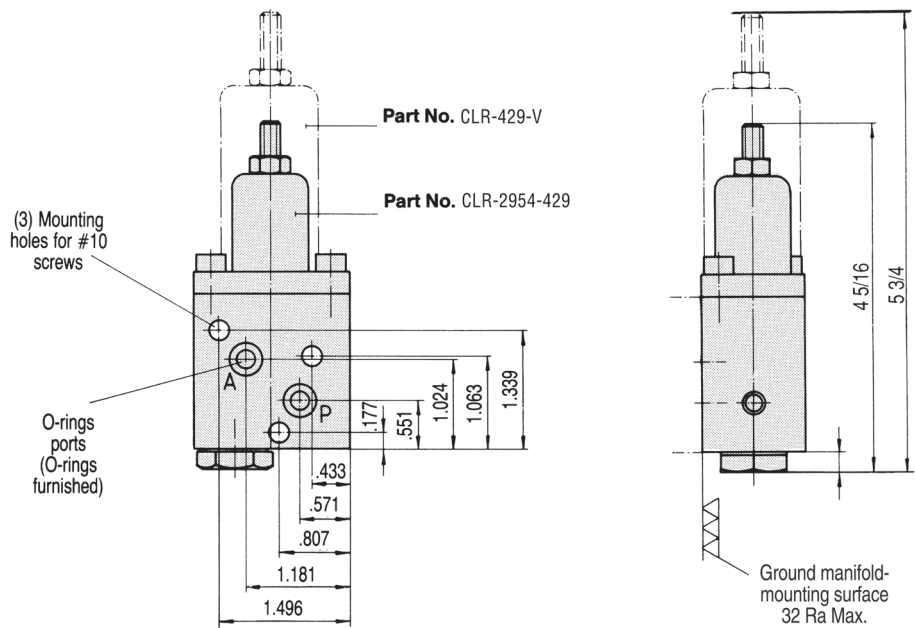

Series Mounted

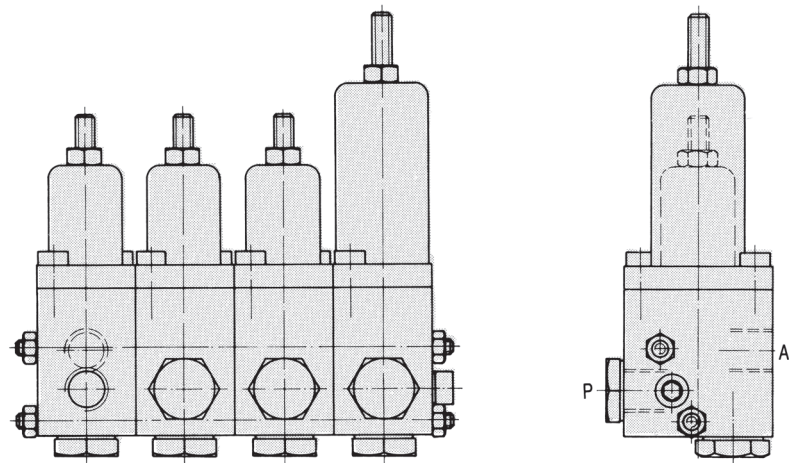

Hydraulic Diagram

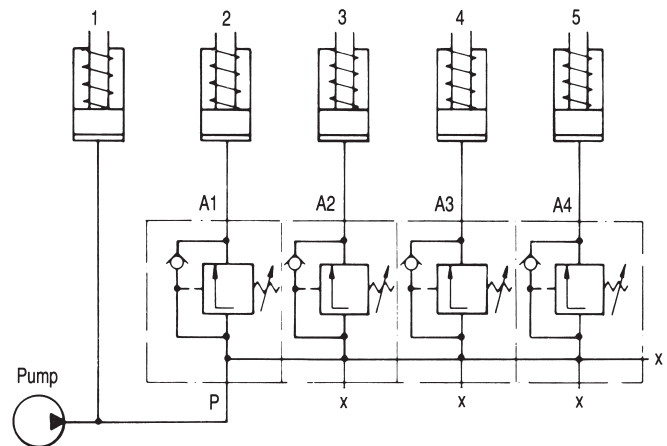

Ordering Example:
Series combination of three low-range sequence valves and one normal-range sequence valve:
(1) CLR-2954-427-V Input Valve
(2) CLR-2954-428-V Series Valve
(1) CLR-2954-442-V Series Valve
(2) CLR-3619-032-VA Connecting bolts



ROEMHELD
HILMA ■ STARK

Carr Lane Roemheld Mfg. Co.
Sales — Phone (314) 647-6200 Fax (314) 647-5736
Engineering — Phone 1-800-827-2526 Web roemheld-usa.com



Pipe Connection Type

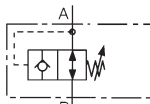

Symbol

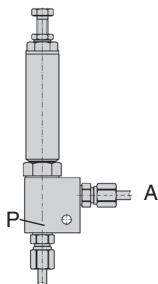

- Allows operating a single clamp, or group of clamps, at a lower pressure than the rest of the fixture.
- Great new design that can be used on pallet fixtures disconnected from a power source, since no return line is needed
- Allows fine tuning of the clamping force for selected components while keeping others at full pressure
- Holds reduced pressure to exact setting, regardless of input pressure
- Zero leakage poppet design

OPERATION: Adjust the downstream pressure using the adjusting screw on top of valve. The valve shuts off downstream fluid flow as soon as the system pressure equals the set pressure. As long as the system is connected to the power source, the valve will open again, if additional fluid is required to maintain the downstream pressure. Valve is also ideal for use on palletized (uncoupled) systems.

UNIQUE FEATURES: In normal systems (connected to power source) valve performs as a true pressure reducing valve, and in Palletized (uncoupled) systems as a pressure closing valve.

DESIGN CONSIDERATIONS: When using this valve in series with other valves (clamp/unclamp valves, sequence valves, etc.) the pressure reducing valve must be the one closest to the clamp(s) that it is protecting. When used in uncoupled systems, it is strongly recommended that a pressure relief valve be included to prevent pressure increases in the downstream (low pressure) side of the system.

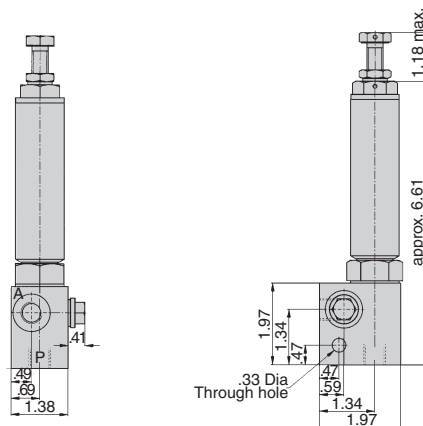

Ports A, P and M = 1/4 BSPP

Application example

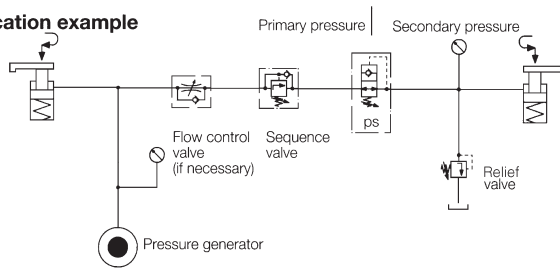

Limit curve of the lowest possible adjusting pressure $P_{A \text{ min.}}$ as a function of the operating pressure P_P

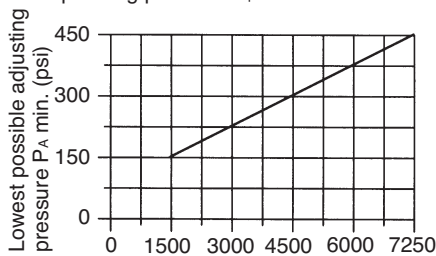

Primary pressure P_P (psi) (Operating pressure of the pressure generator)

Output pressure setting range (psi)	450 to 5500
Valve Type	Poppet
Max. operating pressure (psi)	7250
Output repeatability (psi)	±75
Max. hysteresis to re-open (psi)	375
Approx. pressure change per rotation (psi)	580
Max. fluid flow rate (cu.in./min.)	600
Range of adjustment (psi)	435-5510
Weight, approx. (lbs)	2.9
Part No.	CLR-2953-111-V



Carr Lane Roemheld Mfg. Co.
 Sales — Phone (314) 647-6200 Fax (314) 647-5736
 Engineering — Phone 1-800-827-2526 Web roemheld-usa.com

Pilot-Operated Check Valves

7250 psi max

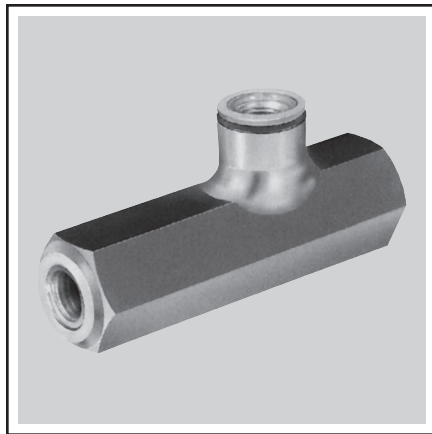

In-Line Mounted

- Holds clamping pressure until released by a separate pilot pressure line
- Allows only one-way flow until released
- Excellent safety device if fluid line to fixture may become damaged
- May be used to prevent workpieces from floating between opposing clamps
- Spring-loaded ball-seat valve (leakage free)

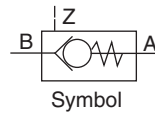

OPERATION: The flow from B to A is free. The flow from A to B is locked, but can be hydraulically unlocked by pressurizing control port Z.

CONTROL PRESSURE: To unlock the check valve for return flow, control (pilot) pressure must be greater than $(0.32 \times \text{Pressure}_A) + 175$ psi for the smaller valve and $(0.38 \times \text{Pressure}_A) + 175$ psi for the larger size.

MOUNTING: In-line mounting with tubing connectors. Control port Z is 1/4 BSPP. Ports A & B are 1/4 BSPP on the smaller size, 1/2 BSPP on the larger size. To reduce 1/2 BSPP to 1/4 BSPP, order adaptor CLR-3613-015-F.

DESIGN CONSIDERATIONS: This pilot-operated check valve is not suitable for locking of double-acting swing clamps (pull-type cylinders). Due to the unfavorable surface ratio of these elements, the control pressure is not sufficient for unlocking and dangerous pressure intensification can occur.

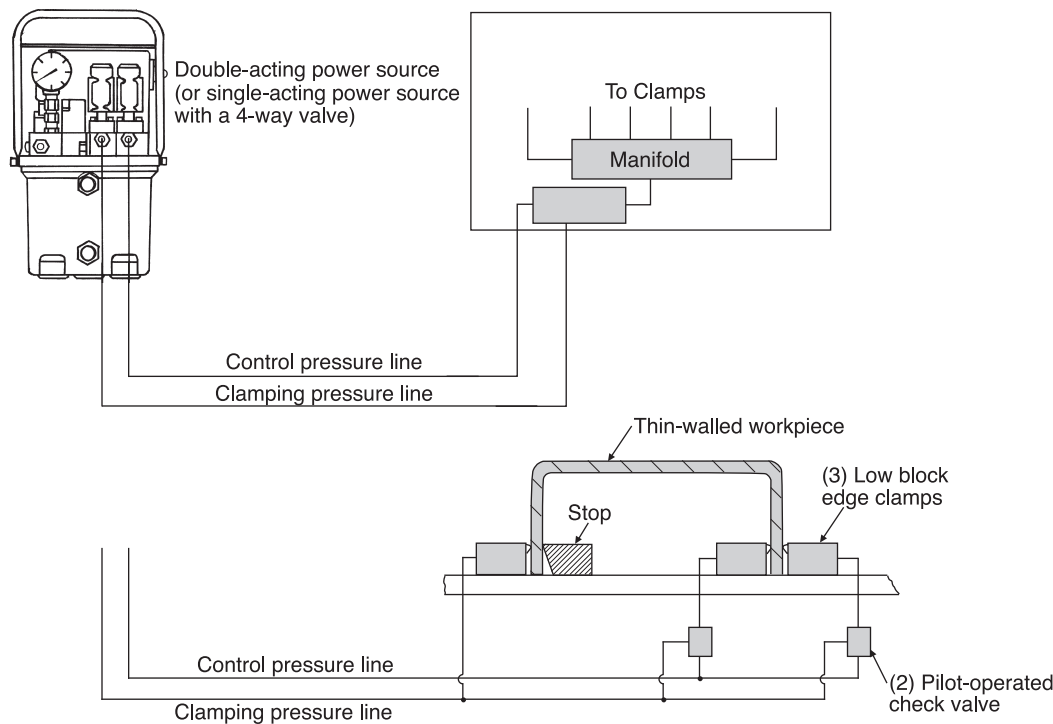

Example 1:

Workpieces remain clamped even if fluid line between power source and fixture becomes damaged.

Example 2:

Two opposing clamps (on right side) allow the workpiece to float between them to avoid distorting it. Without check valves, the workpiece would remain unstable since either clamp could retract or extend further by shifting fluid to the other. Check valves lock the clamps in their settled position by allowing only one-way flow.

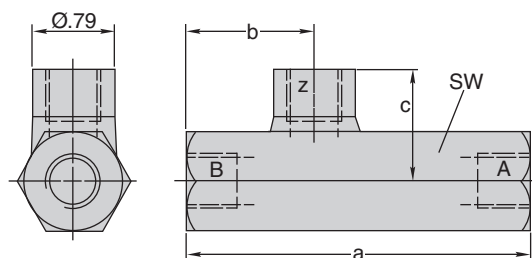

Max. flow rate (cu. in./min.)	920	3360
Max. operating pressure (psi)	7250	7250
Control fluid volume (cu. in.)	.01	.02
Port size, A & B	1/4 BSPP	1/2 BSPP
Port Size, Z	1/4 BSPP	1/4 BSPP
a	3.31	3.94
b	1.24	1.44
c	1.06	1.22
SW	24mm	32mm
Weight (lbs)	.9	1.3
Part No.	CLR-2951-417-V	CLR-2951-501-V



Carr Lane Roemheld Mfg. Co.
 Sales — Phone (314) 647-6200 Fax (314) 647-5736
 Engineering — Phone 1-800-827-2526 Web roemheld-usa.com

Shutoff Valves

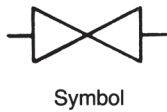
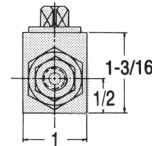
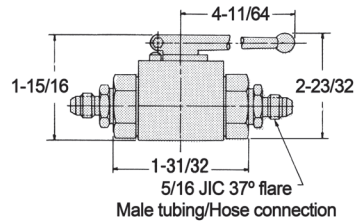
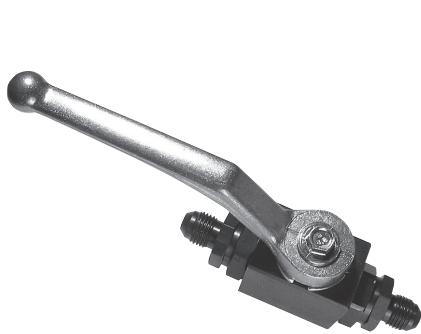

APPLICATIONS:

1. Shutting off unused lines in a multi-purpose fixture.
2. Holding fixture pressure temporarily while transporting with power source disconnected.

DESIGN CONSIDERATIONS: Note: a shutoff valve cannot be used to clamp and unclamp. See valves section for clamping valves.

Max. operating pressure (psi)	7250
Mounting	In line
Lever Movement	90°
Weight (lbs)	0.7
Part No.	CLR-400-V

Relief Valves

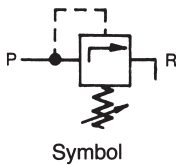
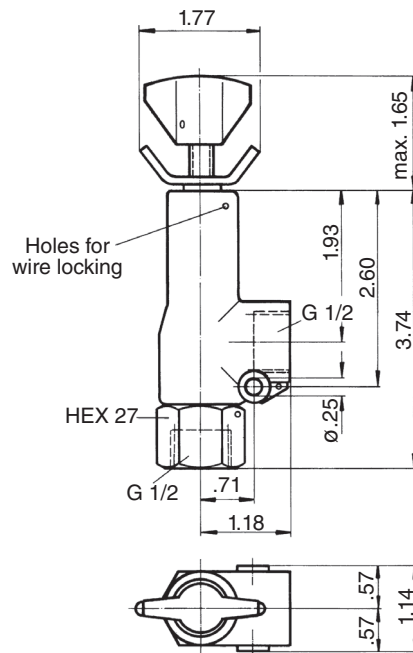

APPLICATIONS: To protect hydraulic circuits from unexpected pressure increases, such as when the temperature of a closed system increases beyond maximum operating pressure.

CONSTRUCTION: Poppet-type valve, directly controlled.

Max. operating pressure (psi)	7250
Adjustment range (psi)	0-7250
Mounting	In line
Weight (lbs)	0.66
Part No.	CLR-2952-521

Flow Control Valves

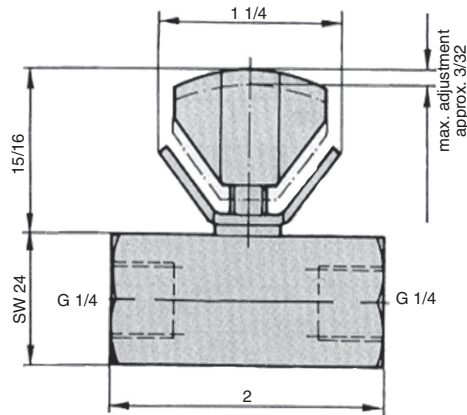

APPLICATIONS: To restrict flow from highflow-rate power sources for proper component operation (Swing Clamps, Extending Clamps, and Fluid-Advanced Work Supports for example).

OPERATION: Turn knob for precision flow control in one direction, with unrestricted free flow in the opposite.

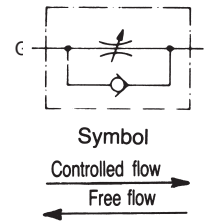

Max. operating pressure (psi)	7250
Mounting	In line
Weight (lbs)	0.7
Part No.	CLR-541-V

Check Valves

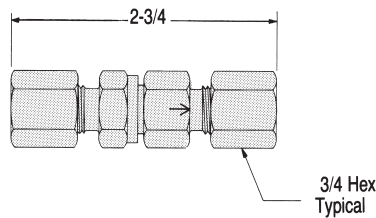

APPLICATION: Simple flow restrictor. Allows fluid to flow in only one direction (see arrow).

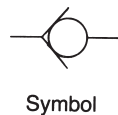

Cartridge-type check valves are also available. Please contact factory for more information.

















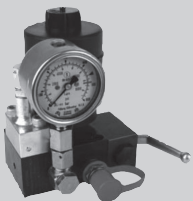





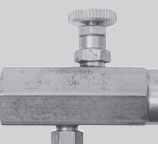

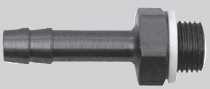
Max. operating pressure (psi)	7250
Mounting	In line
Weight (lbs)	0.3
Part No.	CLR-9208-111



ROEMHELD
HILMA ■ STARK

Carr Lane Roemheld Mfg. Co.
Sales — Phone (314) 647-6200 Fax (314) 647-5736
Engineering — Phone 1-800-827-2526 Web roemheld-usa.com

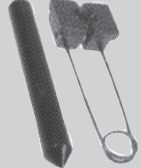
Fittings & Accessories

Rotary Couplings					
					
Single Passage (90°) page 691	Single Passage (straight) page 691	Two Passage page 692	Four Passage page 692	Six Passage page 692	Rotary Valve Couplings page 694
					Rotary Air Valve Couplings page 697
Pallet Coupling			Pressure Monitoring		
					
Pallet Decouplers page 699	Accumulators page 700	Threaded Coupling Elements page 701	Pressure Switches page 703		
Air Accessories					
					
Filter/Regulator/Lubricators page 704	Fine Pressure Regulators page 704	Air Flow Controls page 704	Air Extractor/Dryers page 704	Air Vent Fittings page 716	
Fittings, Tubing, Hose, etc.					
					
Manifolds page 705	Gauges page 705	Hose page 707	Fittings pages 709-710	Fluid Filters page 706	
					
Quick Disconnects page 710	Tubing page 708	Fluid page 708	Tubing Installation & Manifold Mounting page 708		Contact Bolts page 717

Rotary Couplings

7250 psi max
Single acting



Single Passage —
Elbow

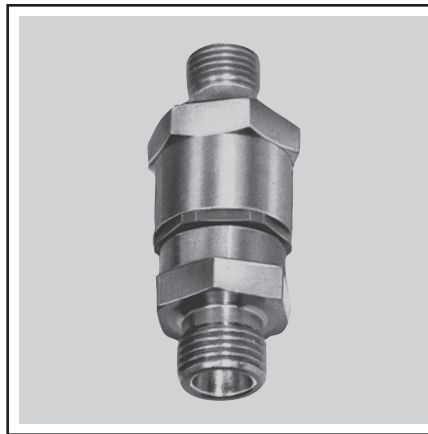
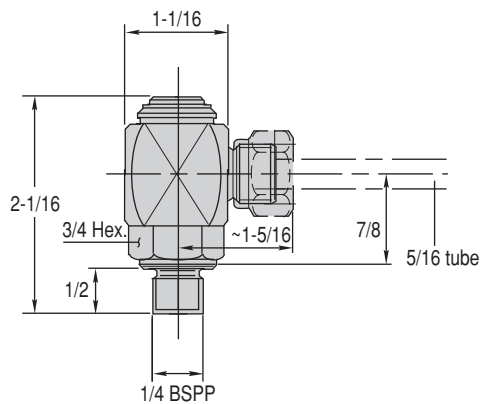
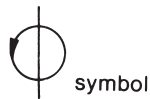

Single Passage —
Straight

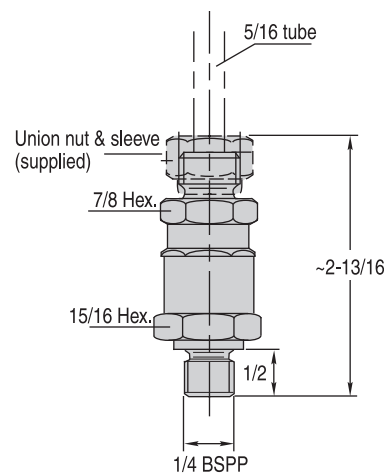
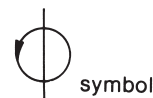

- Best choice for feeding fluid to rotating pallet changers, due to constant connection.
- Ideal for rotary index tables.
- Also good for elbow connections that regularly swing through a small arc
- Choice of elbow or straight version
- ** Do not use NPT fittings

MOUNTING: Mount at rotational center to prevent side loading. Screw into standard 1/4 BSPP port.

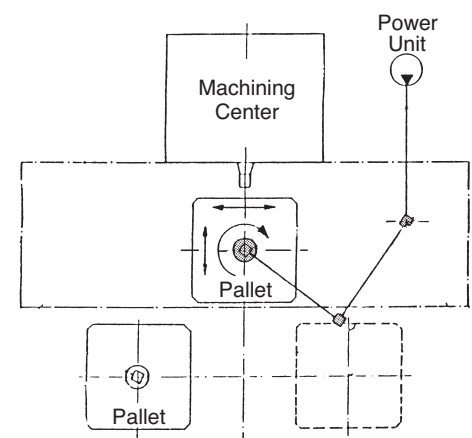

Machining-center pallet changer with continuous fluid feed using Rotary Couplings.

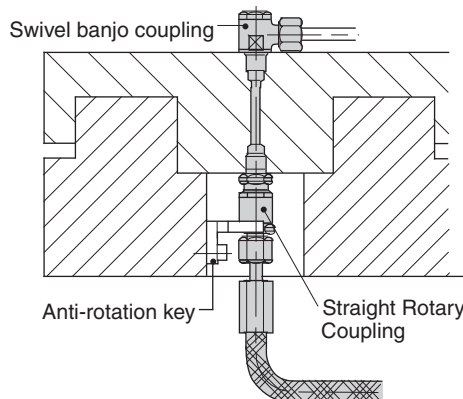
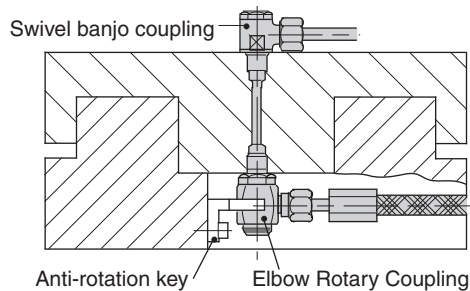

Number of passages	1
Operating pressure range (psi)	145 - 7250
Maximum rotational speed (RPM)	10
Max. seating torque (ft-lbs)	44
Starting torque at 7500 psi (ft-lbs)	1.0
Part No., Elbow	CLR-843-F
Part No., Straight	CLR-845-F



ROEMHELD
HILMA ■ STARK

Carr Lane Roemheld Mfg. Co.
Sales — Phone (314) 647-6200 Fax (314) 647-5736
Engineering — Phone 1-800-827-2526 Web roemheld-usa.com

Rotary Couplings

7250 psi max
Single and double acting



Two Passage



Four Passage



Six Passage

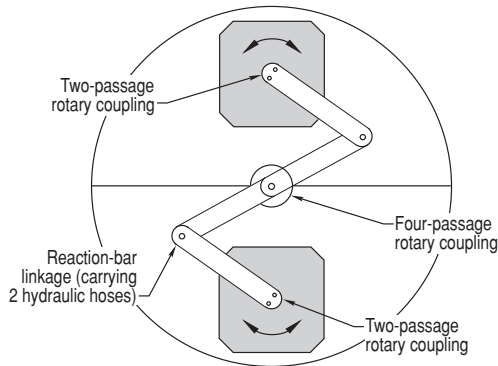
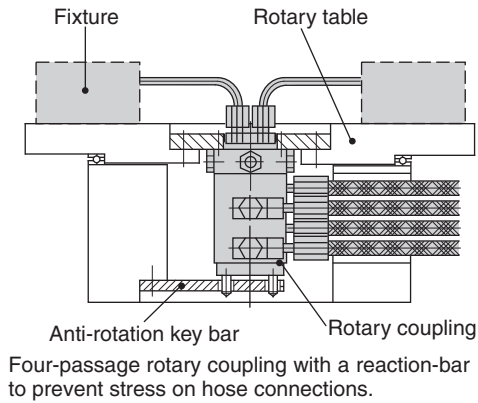
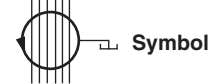

Rotary couplings are frequently used on horizontal machining centers with rotary pallet changers. A reaction-bar linkage holds the top portion of each two-pass coupling stationary while the bottom portion revolves freely. Couplings are not designed to carry load. Side load will cause excessive, uneven wear resulting in failure.

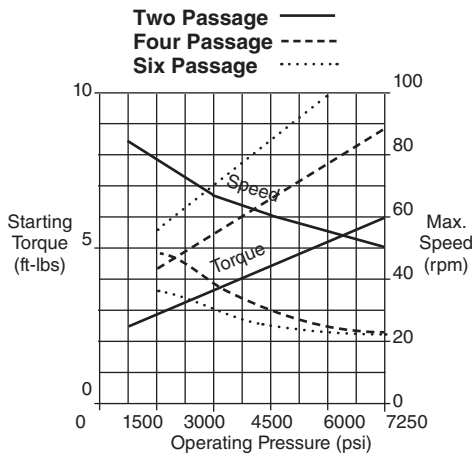

Number of passages	2	4	6
Max. flow rate (cu. in./min.)	493	493	493

Standard			
Leakage rate (cu. in./hr.)	.02	.04	—
Weight (lbs)	5.3	10.1	—
Part No., 150-7250 psi	CLR-9281-136-F	CLR-9284-036	—

With Leakage Recirculation			
Weight (lbs)	6.1	12.1	15.9
Part No., 150-7250 psi	CLR-9281-135	CLR-9284-135	CLR-9286-135



Carr Lane Roemheld Mfg. Co.

Sales — Phone (314) 647-6200 Fax (314) 647-5736
Engineering — Phone 1-800-827-2526 Web roemheld-usa.com

Rotary Couplings

7250 psi max
Single and double acting

- **Best choice for feeding fluid to rotating pallet changers, due to constant connection.**
- **Ideal for rotary index tables.**
- **Can also be used for double-acting clamps.**
- **Choice of two, four, or six independent passages.**
- **Specials are readily available. Please contact factory.**

OPERATION: Each passage is supplied separately. This allows independent operation of two, four, or six (depending on model) sets of spring-return (single-acting) clamps.

MOUNTING: Either the top or bottom can be mounted by screws through the supplied holes. Do not hard mount both sides. Use anti-rotational key on one side.

DESIGN CONSIDERATIONS: The fluid pressure in the rotary coupling will add to the table's starting torque requirement and affect the maximum table operating speed. Please check the graph on the previous page. Fluid must be clean (10 micron or better nominal filtration). Couplings can not be side-loaded. Any weight applied will shorten the life of the unit.

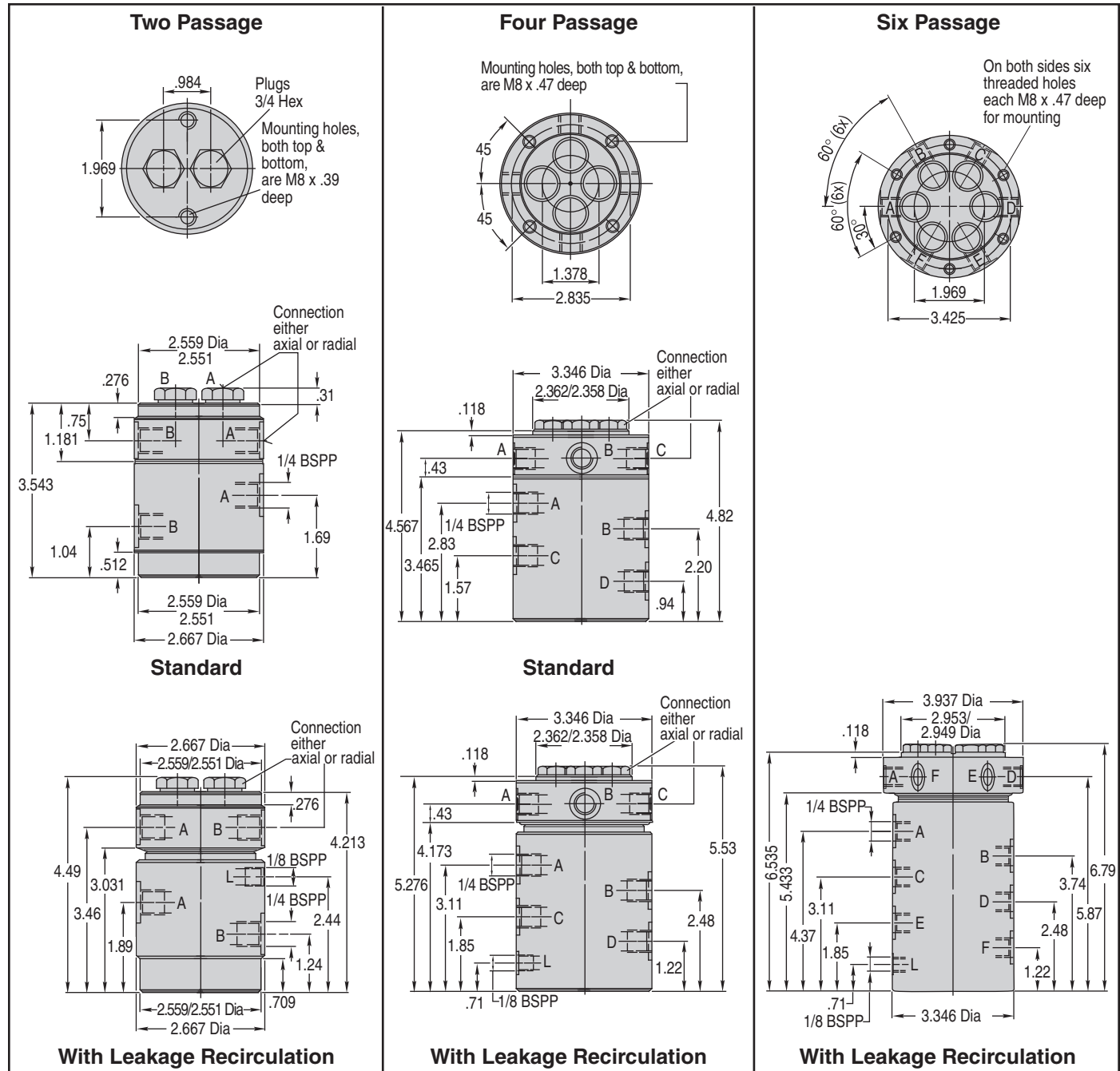

Carr Lane Roemheld Mfg. Co.
Sales — Phone (314) 647-6200 Fax (314) 647-5736
Engineering — Phone 1-800-827-2526 Web roemheld-usa.com

Rotary Valve Couplings

7250 psi max
Single and double acting



- For rotary index tables with an independent load/unload station
- Unload and reload while all other stations remain clamped
- Unclamps automatically at load station, or via a clamping valve
- Available from stock for rotary tables with 2 through 8 stations

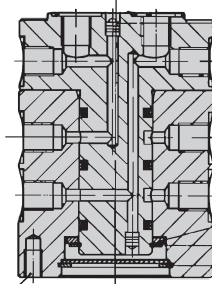

OPERATION: One half of the Rotary Valve Coupling rotates with the index table, while the other half remains stationary. Each time the table and coupling index, a new station automatically becomes the load/unload station. The coupling supplies fluid to the loading station separately from all other stations. The loading station can be either unclamped and resealed automatically as the coupling rotates, or controlled by a separate clamping valve.

CLAMPING MANUALLY: The loading station can be clamped and unclamped manually (or by a machine controller's electrical signal) using a 3-way valve mounted off the rotating table. This insures that a new workpiece will not move during indexing, before it is securely clamped. See valves section for hand-, cam- or air pilot-operated valves. Double-acting clamps require a 4 way valve.

CLAMPING AUTOMATICALLY: To automatically unclamp and reclamp the load station as the coupling rotates, connect the coupling's return line R directly to the power source's reservoir (no pressure). To avoid any pressure drop as the table indexes, the power source's fluid flow rate (cu.in./min.) should be at least 240 times the fluid required at any one clamping station (cu.in.). Otherwise an accumulator must be installed on the pressure line from the power source.

DESIGN CONSIDERATIONS:

1. To use a standard Rotary Valve Coupling, the table must rotate through the same angle during each indexing movement.
2. Turning the coupling requires additional table-motor starting torque, especially when clamping automatically during indexing.
3. Maximum rotational speed is 10 RPM.
4. Use only with the following hydraulic fluids: those listed in F&A section. To use any other hydraulic fluid, check with factory first. Fluid must be clean (10 micron or better nominal filtration).
5. Do not turn coupling while dry, even before installation. Fill unused ports with fluid before capping off (e.g. when using an 8-station coupling for 4 stations).
6. Use only 1/4 BSPP fittings. Fitting-installation torque must be 28-35 ft.lbs.
7. Couplings can not carry load. Especially side load which will cause excessive, uneven wear.
8. With the load station unclamped, there is a small return-line leakage rate. Always install an accumulator, especially above 3000 psi.

MOUNTING: Firmly fasten either the top or bottom half of the coupling using the tapped mounting holes provided. Use a floating reaction bar to prevent the other half from rotating. Mount at the center of rotation, either above, below, or on the rotary table.

SPECIALS: For additional stations or special features, please contact factory.

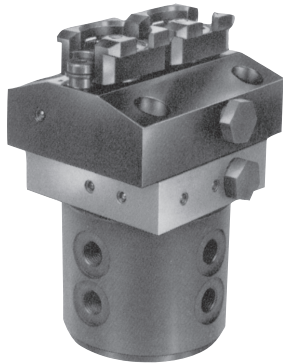

Rotary Valve Couplings are also available for use with automatic coupling systems, for loading multi-sided tooling blocks. Please contact factory for information.

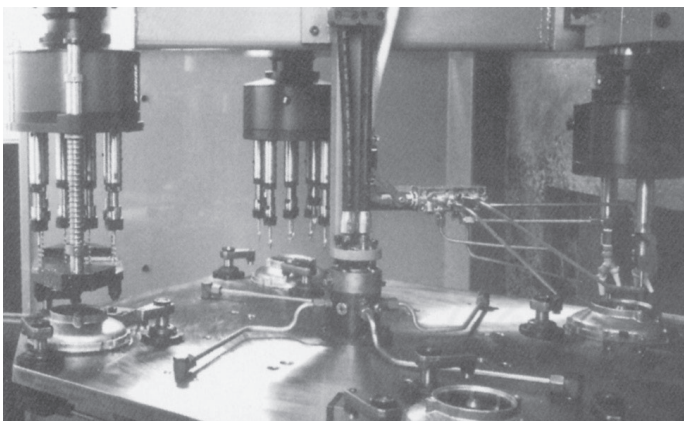

This application shows a multiple-spindle machine with four stations, for machining aluminum covers. An 8-station rotary valve coupling is at the center, with its four unused ports plugged.

Type of clamps	Single Acting	Double Acting
Max. operating pressure (psi)	7250	7250

Type 1 — Single Station for Load/Unload

Part No., 5 station	CLR-9295-001-V	CLR-9295-002-V
Part No., 6 Station (also 2 & 3)	CLR-9296-001-V	CLR-9296-002-V
Part No., 8 Station (also 4)	CLR-9298-001-V	CLR-9298-002-V
Part No., 10 Station	CLR-9290-001-V	CLR-9290-002-V

Type 2 — Two Stations for Load/Unload Commonly Controlled

Part No., 6 station (also 2 & 3)	CLR-9296-011-V	CLR-9296-012-V
Part No., 8 Station (also 4)	CLR-9298-011-V	CLR-9298-012-V
Part No., 10 Station (also 5)	CLR-9290-011-V	CLR-9290-012-V

Type 3 — Two Stations for Load/Unload Separately Controlled

Part No., 6 station (also 2 & 3)	CLR-9296-101-V	CLR-9296-102-V
Part No., 8 Station (also 4)	CLR-9298-101-V	CLR-9298-102-V
Part No., 10 Station (also 5)	CLR-9290-101-V	CLR-9290-102-V

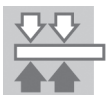

ROEMHELD
HILMA ■ STARK

Carr Lane Roemheld Mfg. Co.

Sales — Phone (314) 647-6200 Fax (314) 647-5736

Engineering — Phone 1-800-827-2526 Web roemheld-usa.com

Rotary Valve Couplings

7250 psi max
Single and double acting

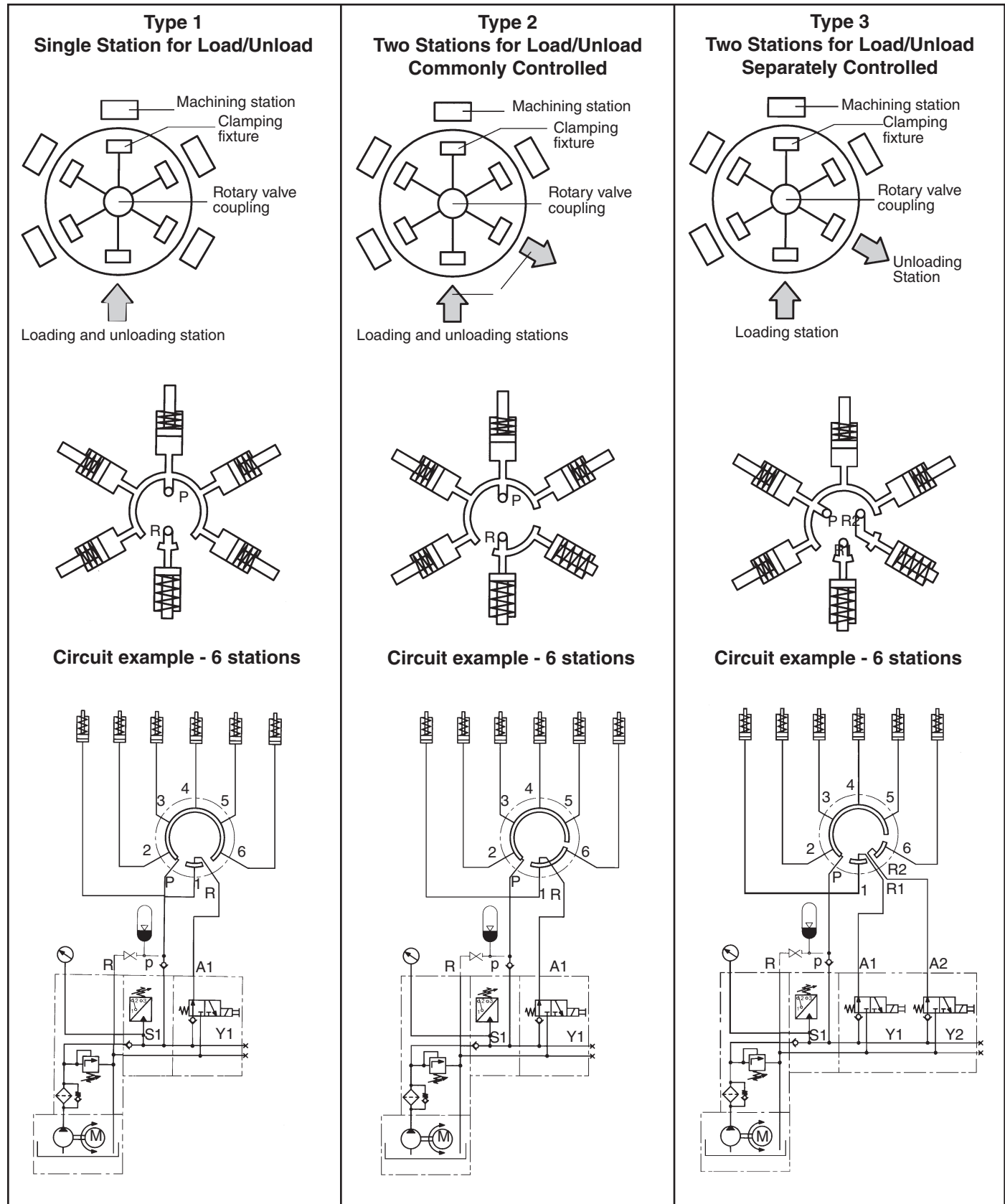

Rotary Valve Couplings

7250 psi max
Single and double acting

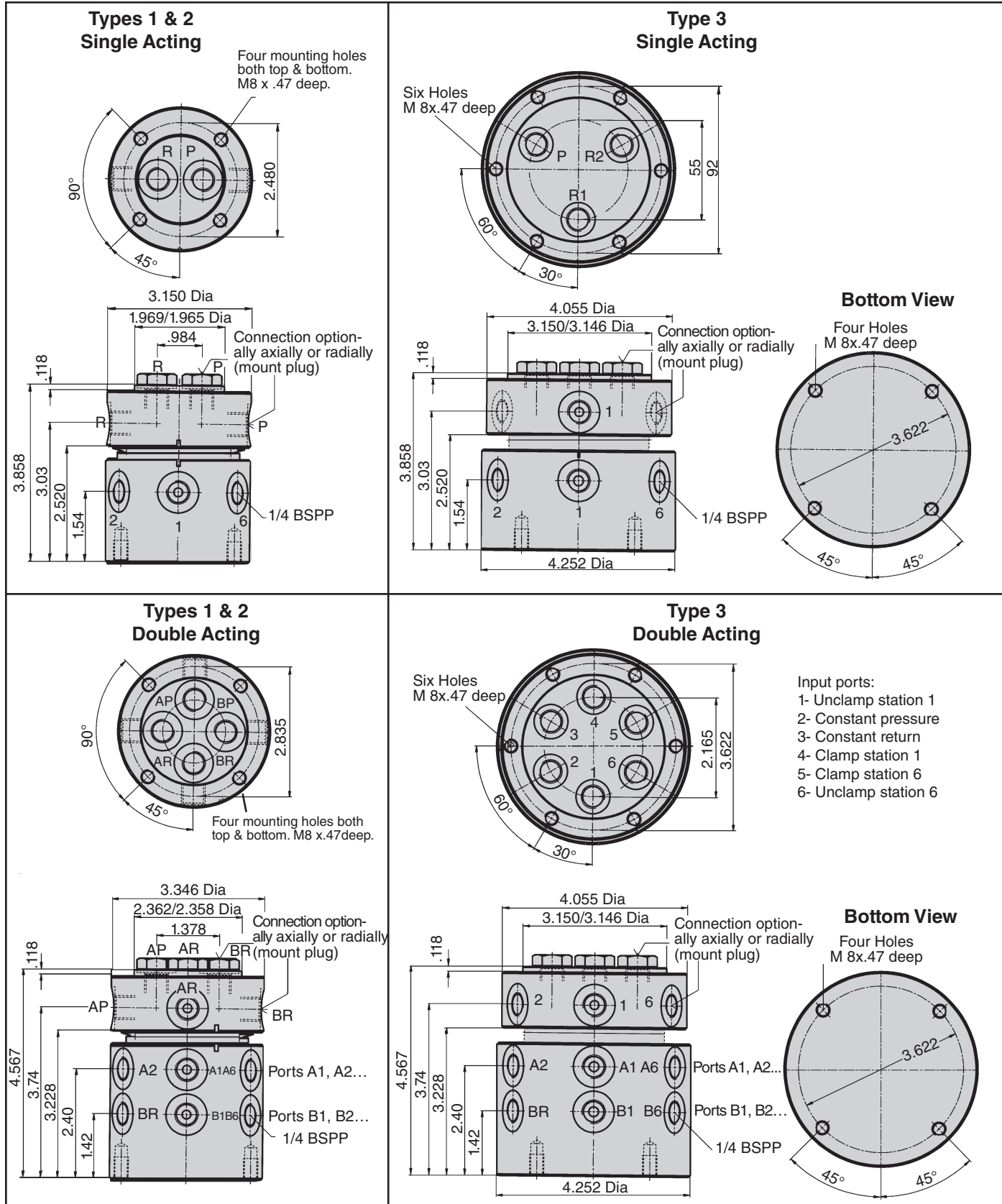

Carr Lane Roemheld Mfg. Co.
Sales — Phone (314) 647-6200 Fax (314) 647-5736
Engineering — Phone 1-800-827-2526 Web roemheld-usa.com

Rotary Air Valve Couplings

145 psi air max
Single and double acting

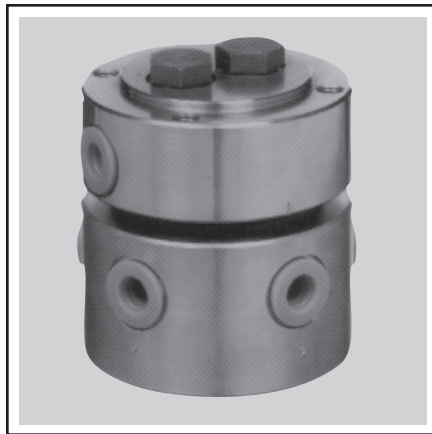

Single Acting

- For rotary index tables with an independent load/unload station
- Unload and reload while all other stations remain clamped
- Unclamps automatically at load station, or via a clamping valve
- Available from stock for rotary tables with 2 through 10 stations

OPERATION: One half of the Rotary Valve Coupling rotates with the index table, while the other half remains stationary. Each time the table and coupling index, a new station automatically becomes the load/unload station. The coupling supplies loading station separately from all other stations. The loading station can be either unclamped and reclamped automatically as the coupling rotates, or controlled by a separate clamping valve.

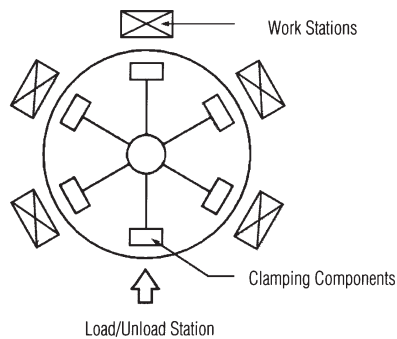

Single Acting

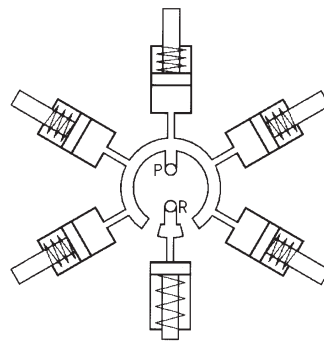

Double Acting

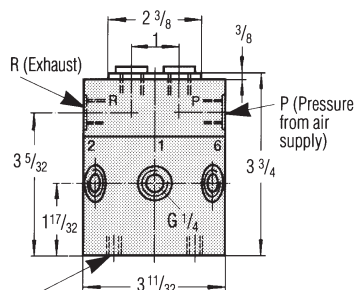
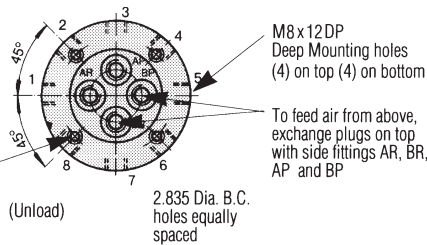
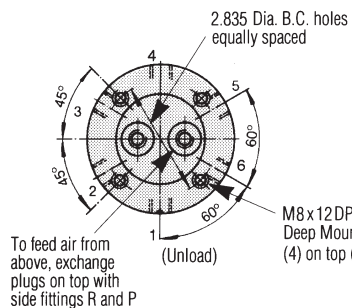

Bottom connections supply to each fixture station (1/4 BSPP Port, 1/4 BSPP male to 1/4 NPT adapter supplied. Ingestion of pipe dope or teflon tape may cause malfunction or damage to valve)

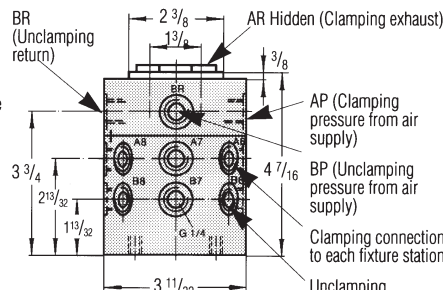

DESIGN CONSIDERATIONS:

1. To use a standard Rotary Valve Coupling, workpiece must be unloaded and reloaded at the same station. Also, the table must rotate through the same angle during each indexing movement.
2. Turning the coupling requires additional table-motor starting torque, especially when clamping automatically during indexing.
3. Maximum rotational speed is 10 RPM.
4. Although couplings are well sealed, an external cover may be necessary to protect the coupling's siding surfaces against extreme dirt and grit.

CLAMPING BY CONTROL VALVE: The loading station can be clamped and unclamped manually (or by a machine controller's electrical signal) using a 3-way valve mounted off the rotating table. This insures that a new workpiece will not move during indexing, before it is securely clamped. Double-acting clamps require a 4-way valve.

MOUNTING: Firmly fasten either the top or bottom half of the coupling using the tapped mounting holes provided. Use a floating reaction bar to prevent the other half from rotating. Mount at the center of rotation, either above, below, or on the rotary table.

SPECIALS: For additional stations or special features, please contact factory. Possibilities include:

1. Any number of stations
2. Multiple load stations (2 or more)
 - Controlled independently or together
 - Side by side, opposite, or at any other orientation

Type Clamp	Single-Acting	Double-Acting
Max. Operating Pressure (psi)	145	145
Part No., 5 Station	CLR-9295-601-V	CLR-9295-602-V
Part No., 2, 3, 6 Station	CLR-9296-601-V	CLR-9296-602-V
Part No., 7 Station	CLR-9297-601-V	CLR-9297-602-V
Part No., 4, 8 Station	CLR-9298-601-V	CLR-9298-602-V



ROEMHELD
HILMA ■ STARK

Carr Lane Roemheld Mfg. Co.
Sales — Phone (314) 647-6200 Fax (314) 647-5736
Engineering — Phone 1-800-827-2526 Web roemheld-usa.com

Pallet Decouplers

7250 psi max
Single acting

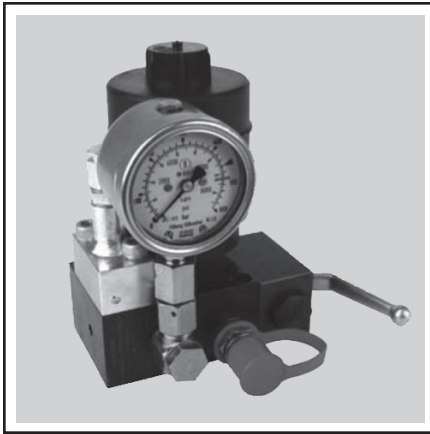

Single Acting

- Allows disconnecting a single-acting fixture from its power source before machining
- Compact assembly mounts easily on fixture (lay gauge flat for an even lower profile)
- Ideal for pallets and rotating fixtures where a fluid feed line is impractical
- Decoupler includes shutoff valve, quick disconnect, accumulator, pressure gauge, and pressure-relief valve
- Do not use NPT fittings

POWER UNIT: Any standard single-acting power unit can be used with this pallet decoupler.

OPERATION:

1. Remove protective cap from male quick disconnect on decoupler. Clean coupling components if necessary.
2. Connect hydraulic hose, with female quick disconnect, to the pallet decoupler. The power unit should be in unclamped mode (depressurized) before connection.
3. Open shutoff valve on decoupler to unclamp fixture.
4. After unloading and reloading fixture, actuate power unit to clamp.
5. After pressure gauge shows proper clamping pressure, close shutoff valve on decoupler.
6. Switch power unit to unclamped mode.
7. Disconnect hose and replace protective cap on male quick disconnect. Hose can be connected to optional safety support while not in use.

SAFETY FEATURES: Pallet decouplers include an accumulator to compensate for pressure changes due to temperature variations. Important: use pallet decouplers only with Roemheld components, because all system components must be zero leakage. These decouplers are equipped with a pressure-relief valve to protect the fixture and the accumulator from extreme temperature increases. An optional safety support with a limit switch can be used to hold the hydraulic hose after uncoupling, to ensure that the fixture is disconnected before moving.

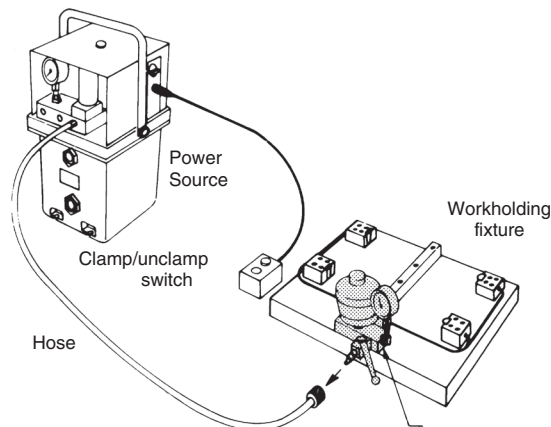
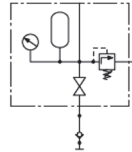
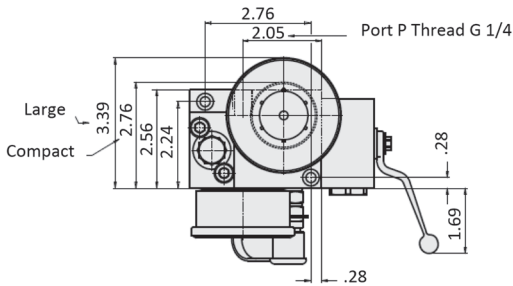
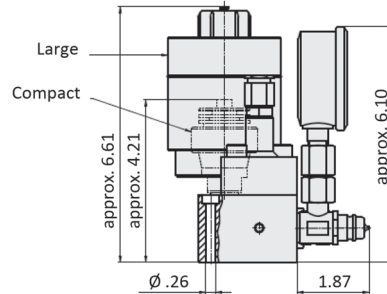
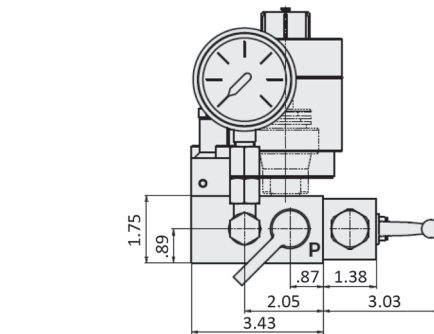

Accumulator Size	Compact	Large
Maximum operating pressure (psi)	7250	7250
Minimum operating pressure (psi)	1800	1800
Accumulator volume at 7250 psi (cu. in.)	0.6	3.4
Accumulator volume at 1800 psi (cu. in.)	0.16	0.9
Accumulator gas preload (psi)	1450	1450
Weight (lbs)	8.4	12.7
Part No., Decoupler	CLR-9425-012-PD	CLR-9425-011-PD
Part No., Female Disconnect	CLR-9384-106-F	
Part No., Safety Support	CLR-0942-001-PDA	



Carr Lane Roemheld Mfg. Co.
Sales — Phone (314) 647-6200 Fax (314) 647-5736
Engineering — Phone 1-800-827-2526 Web roemheld-usa.com

Pallet Decouplers

7250 psi max
Single or double acting

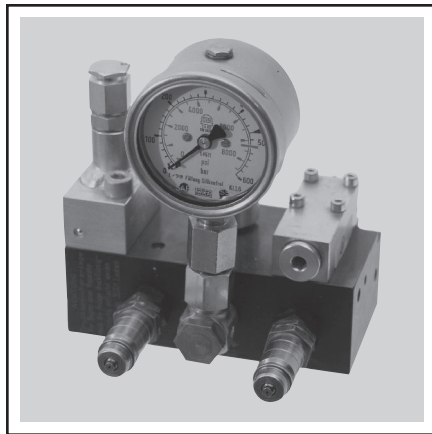

Single Acting or Double Acting with Automatic Shutoff

- Allows disconnecting a single-acting fixture, a double-acting fixture, or a fixture with several individual clamping valves from its power source before machining
- Automatic shutoff using a pilot-operated check valve...no manual shutoff valve required!
- Compact assembly mounts easily on fixture
- Ideal for pallets and rotating fixtures where a fluid feed line is impractical
- Decoupler includes pilot-operated check valve, quick disconnects, accumulator, pressure gauge, and pressure-relief valve

POWER UNIT: A double-acting power unit with a four-button control switch (B1, B2, B3, B4) is required to use this pallet decoupler for either a single-acting fixture or a double-acting fixture. The power unit provides automatic shutoff capability, via the decoupler's pilot-operated check valve, and allows depressurizing both pressure hoses simultaneously for uncoupling. See table below for power-unit part number. This pallet decoupler can also be used where clamping is controlled by individual clamping valves on the fixture (3-way valves for single acting or 4-way valves for double acting). In that application, one constant-pressure hose and one return hose are connected to the decoupler, so any standard single-acting power unit can be used.

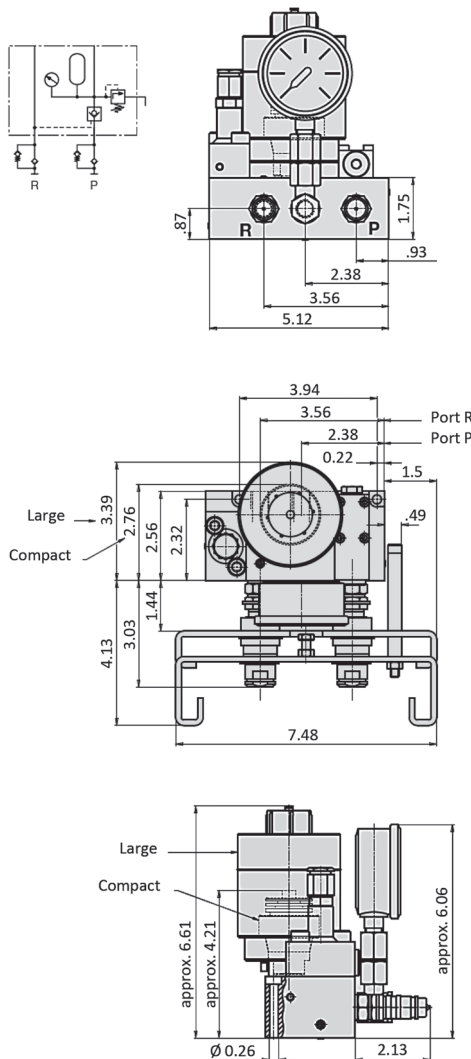

Female Disconnect Double Coupler

(order separately)

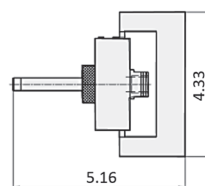

OPERATING SEQUENCE FOR UNCLAMPING/CLAMPING:

A) SINGLE-ACTING CYLINDERS

Operating sequence for **unclamping** with coupling for single-acting cylinders:

- 1) Remove dust cap and clean coupling parts, if necessary.
- 2) Connect coupler of quick-disconnect coupling in depressurized mode.
- 3) Open high-pressure shut-off valve.

Operating sequence for **clamping** with coupling unit for double-acting cylinders.

- 1) Coupler of quick-disconnect coupling is coupled and high-pressure shut-off valve is opened.
- 2) Actuate power unit until pressure gauge shows required clamping pressure.
- 3) Shut high-pressure shut-off valve.
- 4) Set pressure generator to unclamping position.
- 5) Disconnect coupler of quick-disconnect coupling and put into a safety support, if necessary.
- 6) Attach dust cap to coupling nipple and coupler.

B) DOUBLE-ACTING CYLINDERS

Operating sequence for **unclamping** with coupling unit for double-acting cylinders:

- 1) Remove dust cap and clean coupling parts, if necessary.
- 2) Connect multi-coupler in depressurized mode: For the purpose switch selector switch to **"couple."**
- 3) Switch selector switch to **"unclamp."**

Operating sequence for **clamping** with coupling unit for double-acting cylinders.

- 1) Multi-coupler is coupled.
- 2) Switch selector switch to **"clamp."** After pressure build up, the green lamp is signaled.
- 3) Set multi-coupler to depressurized mode: For the purpose switch selector switch to **"couple."**
- 4) Disconnect multi-coupler and put it into a safety support, if necessary.
- 5) Attach dust cap to coupling nipple and coupler.

SAFETY FEATURES: Pallet decouplers include an accumulator to compensate for pressure changes due to temperature variations. Important: use pallet decouplers only with **Roemheld** components, because all system components must be zero leakage. These decouplers are equipped with a pressure-relief valve to protect the fixture and the accumulator from extreme temperature increases. An optional safety support with a limit switch can be used to hold the double coupler after uncoupling, to ensure that the fixture is disconnected before moving.

Accumulator Size	Compact	Large
Maximum operating pressure (psi)	7250	7250
Minimum operating pressure (psi)	1800	1800
Accumulator volume at 7250 psi (cu. in.)	0.6	3.4
Accumulator volume at 1800 psi (cu. in.)	0.16	0.9
Accumulator gas preload (psi)	1450	1450
Weight (lbs)	9.6	13.5
Part No., Decoupler	CLR-9425-022-PD	CLR-9425-021-PD
Part No., Female Disconnect Double Coupler	CLR-9425-102-PDA	
Part No., Safety Support	CLR-0942-002-PDA	
Electric Power Unit, 7500 psi, 460V	CLR-939-EP	
Electric Power Unit, 7500 psi, 230V	CLR-839-EP	
Electric Power Unit, 5000 psi, 460V	CLR-940-EP	
Electric Power Unit, 5000 psi, 230V	CLR-840-EP	



ROEMHELD
HILMA ■ STARK

Carr Lane Roemheld Mfg. Co.

Sales — Phone (314) 647-6200 Fax (314) 647-5736
Engineering — Phone 1-800-827-2526 Web roemheld-usa.com

Accumulators

7250 psi max



Compact



Large

- Extremely compact accumulator, ideal for workholding applications
- Can also store fluid potential energy between working cycles
- Operates comfortably at up to 7250 psi
- Choice of large or compact size

****Do not use NPT fittings**

SPECIFICATIONS: Nitrogen-filled diaphragm type accumulator. Allowable operating temperature 15 to 175° F. Install in any position, horizontal or vertical.

DESIGN CONSIDERATIONS:

1. Use only with Roemheld components because all system components should be leakfree.
2. Since a fixture's fluid lines are sealed after disconnection from the power source, fluid pressure will actually increase if fixture temperature increases. This increase can be quite substantial: about 80 psi per 1°F. Be careful not to exceed 7250 psi at any time during the machining cycle. Always install a pressure gauge in the closed system.
3. If the possibility of exceeding 7250 psi exists, install a Relief Valve (see valves section) in the system.
4. Shield accumulator if the possibility of accidental damage exists.

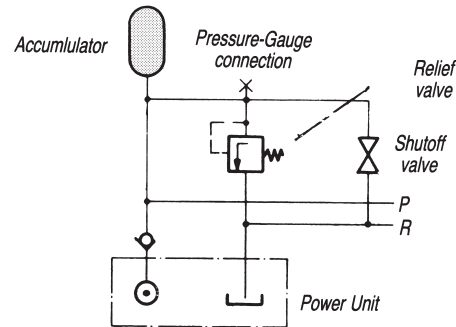
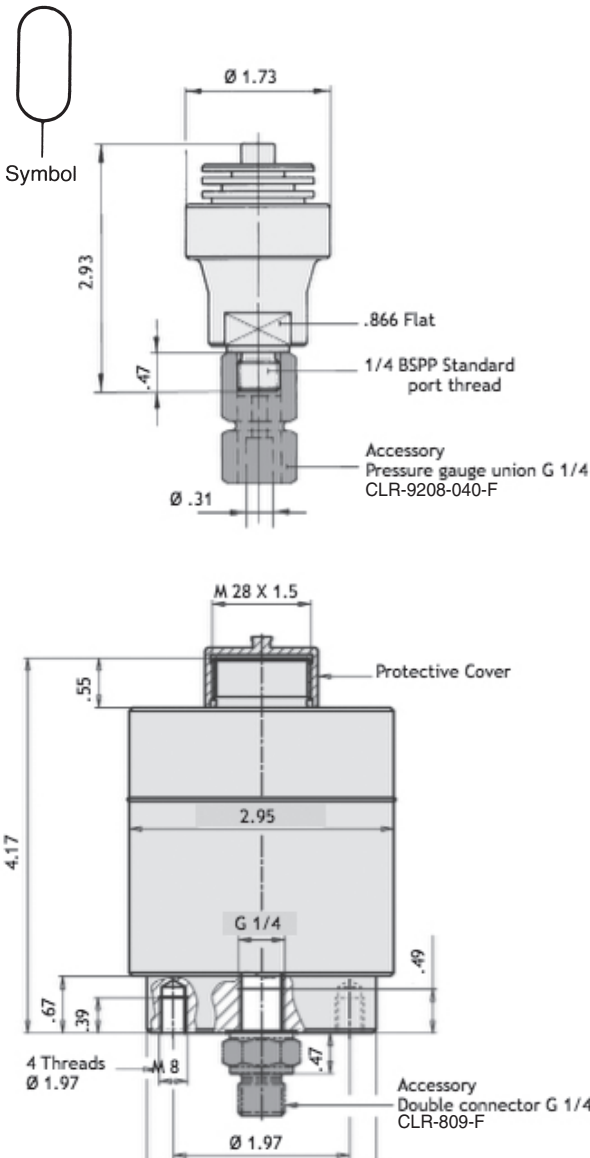

Example:
Accumulator circuit with all safety devices installed.

Size	Compact	Large
Maximum operating pressure (psi)	5800	7250
Minimum operating pressure (psi)	1800	1800
Accumulator volume at 7250 psi (cu. in.)	.60	3.4
Accumulator volume at 1800 psi (cu. in.)	.16	.9
Accumulator gas preload (psi)	1450	1450
Weight (lbs)	0.7	5.0
Part No.	CLR-9606-102-PDA	CLR-9605-611



ROEMHELD
HILMA ■ STARK

Carr Lane Roemheld Mfg. Co.

Sales — Phone (314) 647-6200 Fax (314) 647-5736

Engineering — Phone 1-800-827-2526 Web roemheld-usa.com

Threaded Coupling Elements

7250 psi max



Manifold Mounted

- Very compact coupling units
- Flush mounting in uncoupled mode
- Ideal for pallet coupling with vertical guided connection
- Optional return line relief
- Two sizes with and without coupling against pressure

Depending on the version, the coupling elements can either be coupled in energized mode, or de-energized mode only. The operating mode depends on the type of sealing elements which are used and can be taken from the table below.

The max. positioning tolerances in axial and radial direction are indicated in the table below.

The sealing areas at the side of the coupling elements have to be cleansed before coupling, to ensure the tightness in coupled mode. We recommend to wash the elements and finally clean them with compressed air. Dust caps should be used as far as possible.

APPLICATION: Compared to other coupling elements the threaded coupling elements are very compact devices.

If the slide movement of the workpiece carrier is to be used or if a fixture is to be used or if a fixture is to be connected to the base plate without lines, the threaded nipple and the coupling mechanisms can be directly screwed into the parts which are to be connected. The coupling mechanisms have the advantage that they are flush-faced in uncoupled mode.

Flange-type housings are available to simplify the manufacture of the fixture mounting hole contours. In cramped conditions it is possible to make and install the flange-type housing retrospectively.

The fixture bodies which are to take up the coupling parts have to be guided .125 in. parallel before they are coupled.

The axial forces which arise during the pressure build-up in coupled mode (see diagram) have to be absorbed outside the coupling parts.

The threaded nipples, which are installed into the tank lines, are equipped with a pre-loaded valve (VSV). The pre-loaded valve limits a possible pressure build-up in the return line, caused by internal leakage in the hydraulic clamping elements, to approx. 75 psi. In coupled mode the pre-loaded valve is not effective.

Threaded nipple

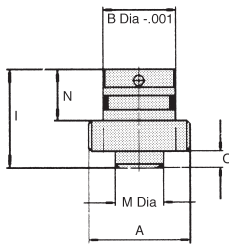

Coupling mechanism

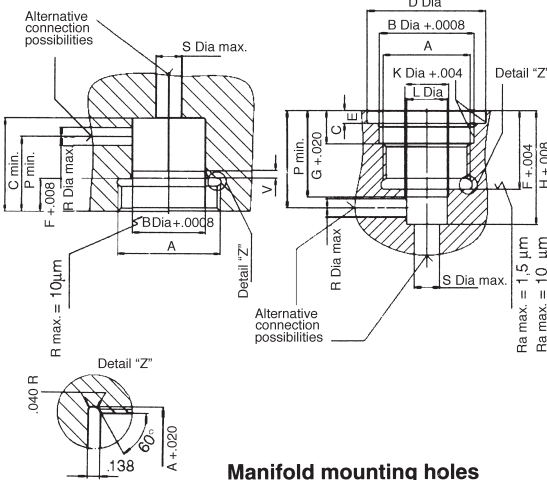
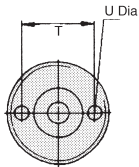
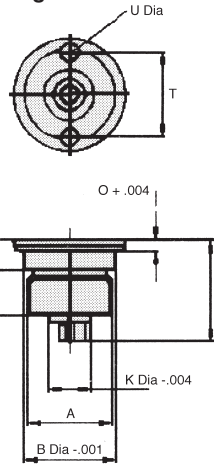

Manifold mounting holes

Element	Coupling mechanism	Threaded nipple	Threaded nipple with VSV	Coupling mechanism	Threaded nipple	Threaded nipple with VSV
Nominal ID	3mm		5mm			
p. max./min.	7250/450	7250/450	7250/450	7250/450	7250/450	7250/450
A	M20x1.5	M24x1.5	M24x1.5	M24x1.5	M28x1	M28x1
B Dia	.8661	.7874	.7874	1.0236	.7874	.7874
C	.138	1.063	1.181	.354	.945	1.181
D Dia	—	—	—	1.280	—	—
E	—	—	—	.138	—	—
F	.846	.394	.394	.846	.335	.335
G	.925	—	—	.925	—	—
H	1.22	—	—	1.22	—	—
I	1.15	1.16	1.34	1.15	1.06	1.280
K Dia	.472	—	—	.472	—	—
L Dia	.441	—	—	.441	—	—
M Dia	—	.59	.268	—	.531	.531
N	.73	.65	.65	.51	.55	.77
O	—	.177	.177	.126	.177	.177
P	1.10	.827	.98	1.10	.81	.81
R Dia	.197	.197	.197	.197	.197	.197
S Dia	.276	.276	.276	.276	.276	.276
T	.630	.670	.670	.945	.787	.787
U Dia	.138	.138	.138	.197	.157	.157
V	—	2x15°	2x15°	1x15°	2x15°	2x15°
max. position tolerance (axial)	+ .020	+ .020	+ .020	+ .020	+ .020	+ .020
max. position tolerance (radial)	+/- .004	+/- .004	+/- .004	+/- .008	+/- .008	+/- .008

Can be coupled with or without pressure

Part No.	CLR-0460-725-TBC	CLR-0460-727-TBN	-	CLR-0460-735-TBC	CLR-0460-638-TBN	-
----------	------------------	------------------	---	------------------	------------------	---

Can be coupled without pressure

Part No.	CLR-0460-730-TBC	CLR-0460-731-TBN	CLR-0460-728-TBN	CLR-0460-736-TBC	CLR-0460-740-TBN	CLR-0460-637-TBN
----------	------------------	------------------	------------------	------------------	------------------	------------------



ROEMHELD
HILMA ■ STARK

Carr Lane Roemheld Mfg. Co.

Sales — Phone (314) 647-6200 Fax (314) 647-5736

Engineering — Phone 1-800-827-2526 Web roemheld-usa.com

Threaded Coupling Elements

Optional Housing for Coupling Mechanism

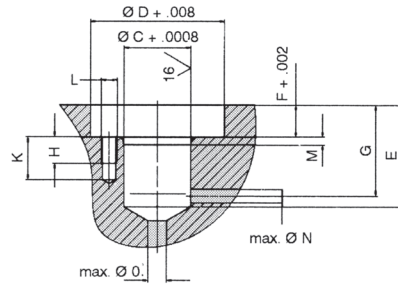
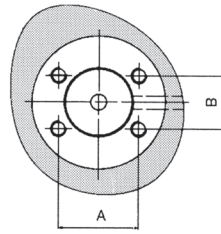
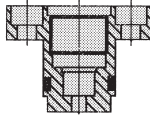
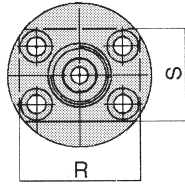

Mounting dimensions

If it is not required that the housing is flush-fitting with the pallet, the D dia. can be omitted. The depth dimensions are then shortened by dimension F.

In cramped installation conditions the housing can be milled according to dimensions R and S.

Housings for Coupling Mechanisms

Useable for	CLR-0460-725-TBC	CLR-0460-735-TBC
A	1.181	1.693
B	.787	.906
C Dia	0.9843	1.2598
D Dia	1.9685	2.5591
E	1.50	1.50
F	0.472	0.591
G min.	1.34	1.38
H	0.39	0.47
K	0.63	0.71
L	1/4-20	5/16-18
M	0.12x15°	0.12x15°
N Dia max.	0.197	0.24
P Dia	0.28	0.28
R	1.65	2.36
S	1.26	1.57
Part no.	CLR-0460-655-TBCH	CLR-0460-654-TBCH

Coupling force

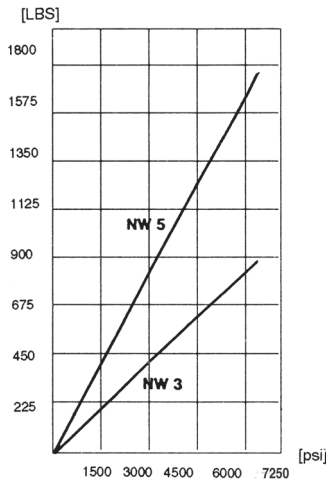

Δp-Q characteristic line for kinetic viscosity from 53x10⁻⁶m²/s

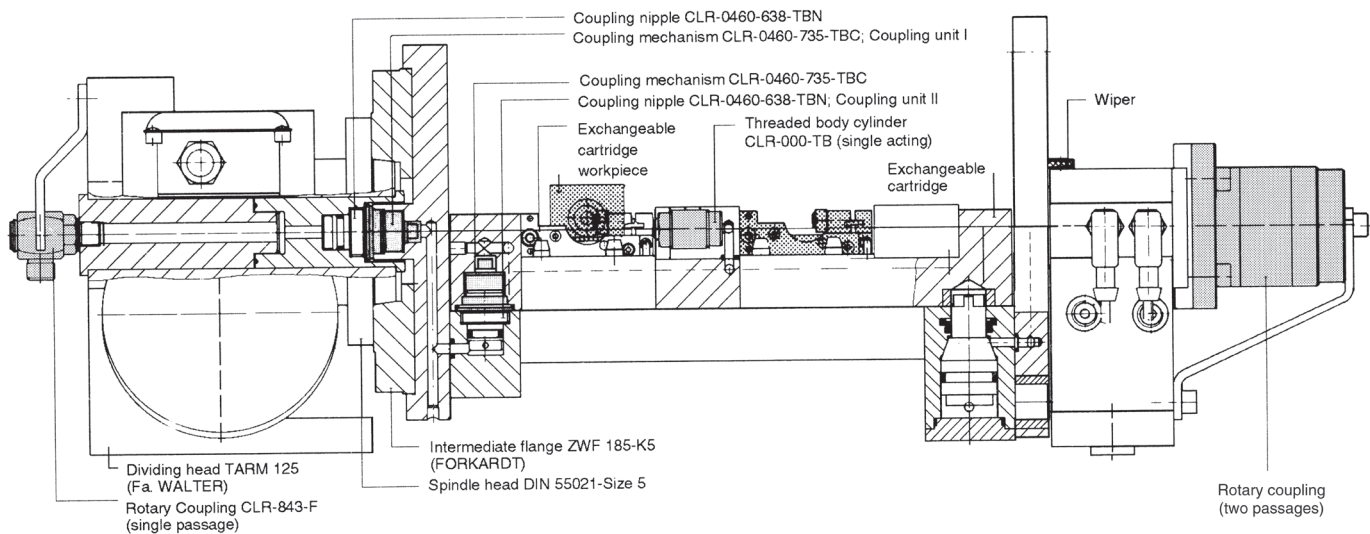
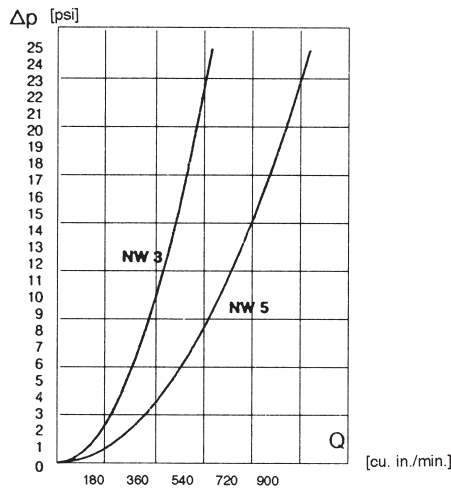

Pressure Switches ■ F9.732

Pressure Switches ■ Hydra-electrical signal converter ■ Pressure adjustment ranges ■ 75-1885 psi, 725-5075 psi & 725-7975 psi (5-130 bar, 50-350 bar & 50-550 bar)

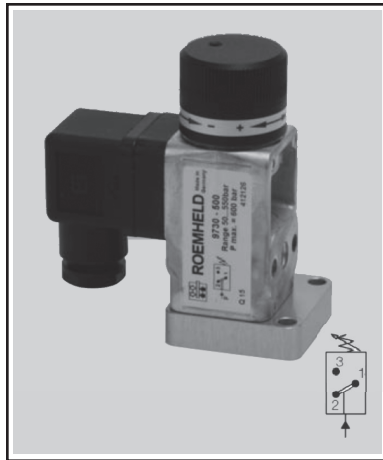

Hydra-electric pressure switches are devices which close or open electrical contacts under pressure. They are used to switch on or off pump motors, valves, machine tool interlocks or similar applications in power units, machines and installations. The switching point can be

adjusted to the desired hydraulic pressure via a knurled knob. The knob can be locked in place by tightening a set screw. The installed microswitch is a change-over switch which can be connected as break or make contact. The electrical connector can be index 4 x 90°.

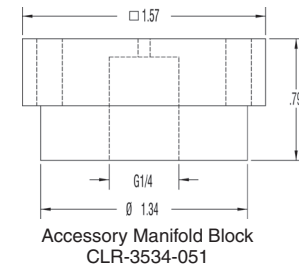
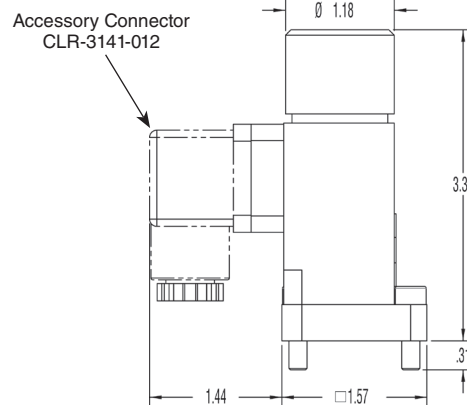

Locking Set Screw

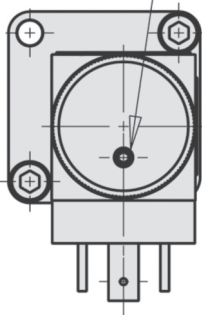

Contact Layout

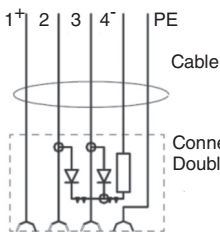

Switching Symbol
Connector with
Double LED
CLR-3141-802



Hydraulic characteristics

Pressure adjustment range	725 - 7975 psi	725 - 5075 psi	75 - 1885 psi
Hysteresis	8 - 12% at 7250 - 3625 psi	8 - 12% at 4350 - 1450 psi	8 - 12% at 1450 - 435 psi
Part No., (switch only)	CLR-9730-500	CLR-9730-501	CLR-9730-502
Part No., (switch + CLR-3141-012 DIN connector)	CLR-9730-500-PS	CLR-9730-501-PS	CLR-9730-502-PS

Electrical characteristics

Connection	DIN 43650 connector, form A
Switching element	Change-over switch
Max. load	4A at 250VAC; max 3.0A at 28VDC; min. 5mA
Code class (ED 60529)	IP 65

Technical characteristics

Operating fluid	Hydraulic oil HLP 22, 32 and 46
Fluid temperature	max. 176 °F
Fluid connection	Manifold mounting or G1/4 with manifold block
Environmental temp.	-50 °F - 176 °F
Max. operating pressure	8700 psi
Vibration resistance	10 g (10 - 2000 Hz)
Shock resistance	30 g
Material	Housing: zinc diecasting Adjusting knob: aluminum (powder coated)
Seals	FKM
Weight	0.72 lbs
Mounting position	Any

Accessories

Part No., Manifold block	CLR-3534-051
Part No., Connector DIN 43650, 4 x 90° indexable	CLR-3141-012
Part No., Connector with 1.97' cable	CLR-3141-928
Part No., Connector with 8.2' cable	CLR-3141-818
Part No., Connector with double LED and 9.84' cable	CLR-3141-802
Part No., Spare FKM O-ring	CLR-3001-147

Subject to change. For further details, including detailed dimensions and mounting instructions, visit roemheld-usa.com.



ROEMHELD
HILMA ■ STARK

Carr Lane Roemheld Mfg. Co.
Sales — Phone (314) 647-6200 Fax (314) 647-5736
Engineering — Phone 1-800-827-2526 Web roemheld-usa.com

Air Filter/Regulator/Lubricator

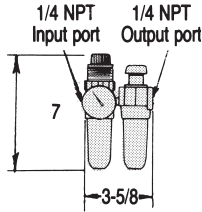

CLR-100-FRL
Recommended for all incoming air-pressure lines (included with air power unit). Filter removes solid contaminants and water from the air supply. Lubricator provides an oil mist to lubricate the system. Regulator is essential to control input air pressure, and thereby control output fluid pressure.

Fine Air-Pressure Regulator

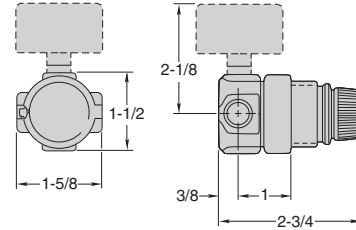

CLR-200-FR
Miniature regulator for adjusting air pressure between 1 and 10 psi (30 psi gauge). Use with air-advanced work supports to finely adjust contact force. 1/4 NPT ports.

Air Extractor/Dryer

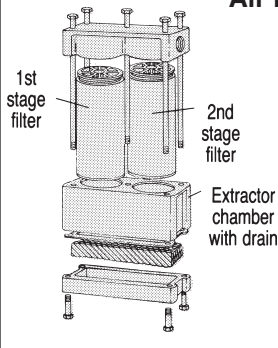

CLR-105F-AED
Effective extractor/dryer that removes air moisture and dirt to increase the life of air-powered components. Replace or clean filter/gasket every 6-12 months (part no. CLR-403-AEDA).

Air Flow-Control Valve



CLR-100-AFC
Simple valve to reduce air flow rates and reduce clamping speed. Release air pressure to adjust setting.

Fluid 6-Port Manifolds

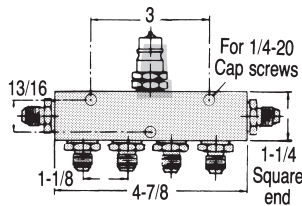

CLR-106-F
(6) Male 37° fittings (1) Male quick disconnect
CLR-107-F
(7) Male 37° fittings
CLR-106-BP
(7) 1/4 BSPP ports, without fittings

Fluid 4-Port Manifolds

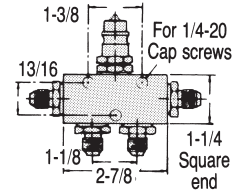

CLR-104-F
(4) Male 37° fittings (1) Male quick disconnect
CLR-105-F
(5) Male 37° fittings
CLR-104-BP
(5) 1/4 BSPP ports, without fittings

Fluid Pressure Gauges

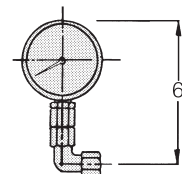
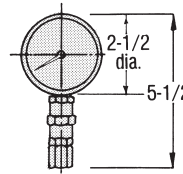
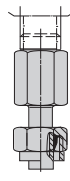
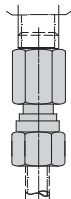
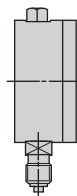

CLR-100-GA
Gauge only without adaptor

CLR-808-F
Female gauge adaptor
Compression type

CLR-9208-041-F
Male gauge adaptor
Compression type

CLR-101-GA
Gauge with
Female 37° fitting

CLR-102-GA
Gauge with Elbow
Female 37° fitting



Quick Disconnects

General Use

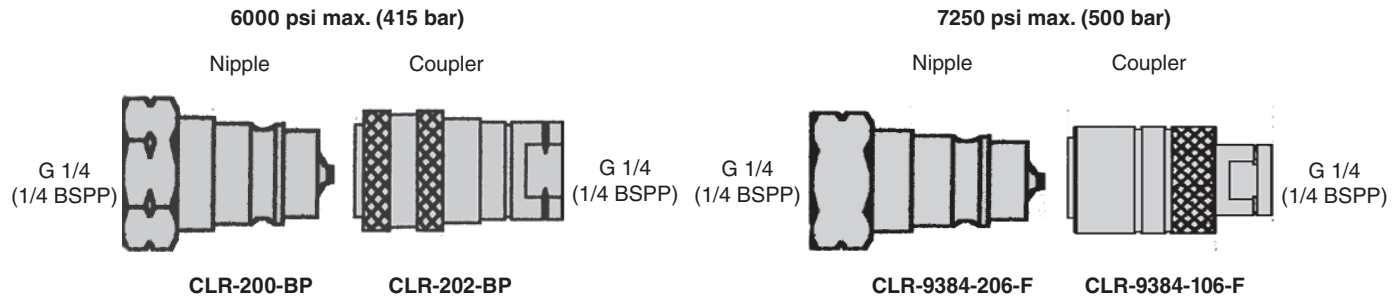

Flat Face Non-Spill

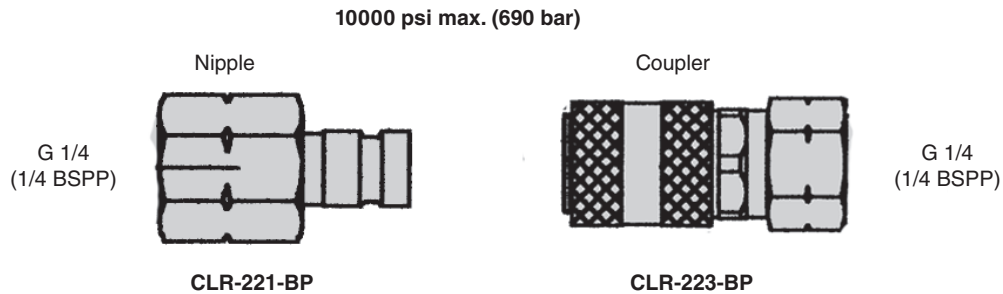

Color Coded with Alignment Pins

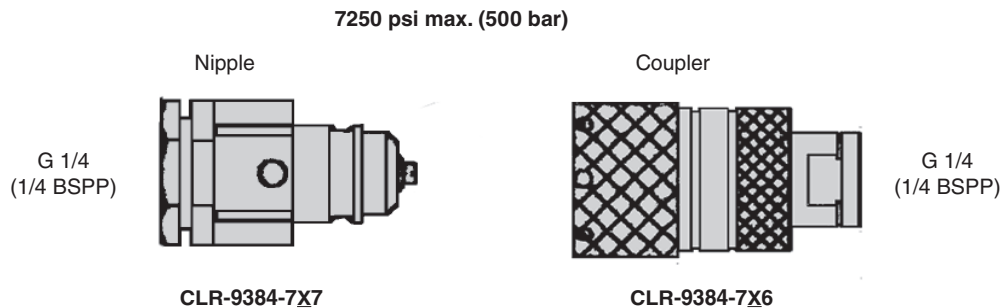

- X Color Code**
 1 = Black
 2 = White*
 3 = Red
 4 = Yellow
 5 = Green
 6 = Blue

Our color coded quick connects are not only easily identified by color but each color contains its own unique alignment pin so that it is physically impossible to mix them up.

* The white nipple only, 9384-727, comes with a built-in pressure relief valve. This limits possible pressure build up due to internal leakage. Relief pressure = 72 psi (5 bar).

*** For G 1/4 fittings and adapters see Fitting Pages**

Subject to change. For further details, including detailed dimensions and mounting instructions, visit roemheld-usa.com.



ROEMHELD
 HILMA ■ STARK

Carr Lane Roemheld Mfg. Co.
 Sales — Phone (314) 647-6200 Fax (314) 647-5736
 Engineering — Phone 1-800-827-2526 Web roemheld-usa.com

High Pressure Inline Filters

7250/3000 psi max



CLR-000-V

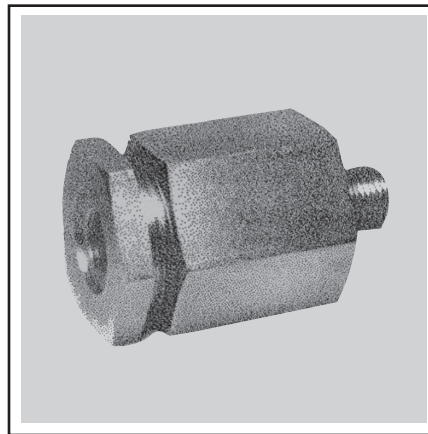

CLR-100-V



CLR-3887-087

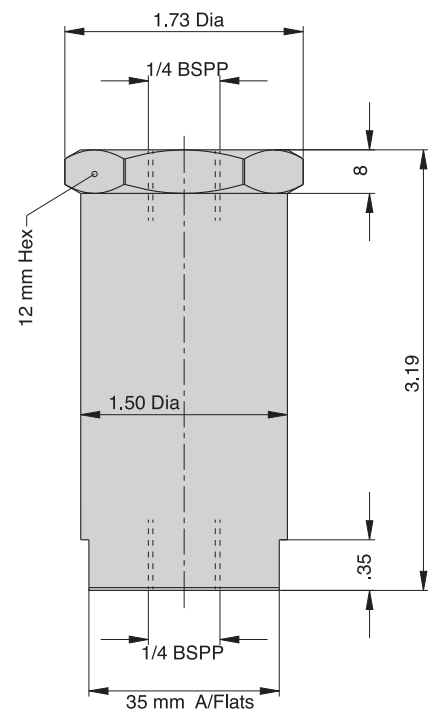
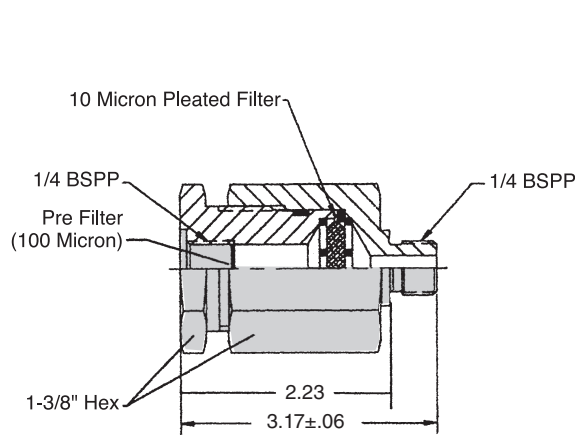
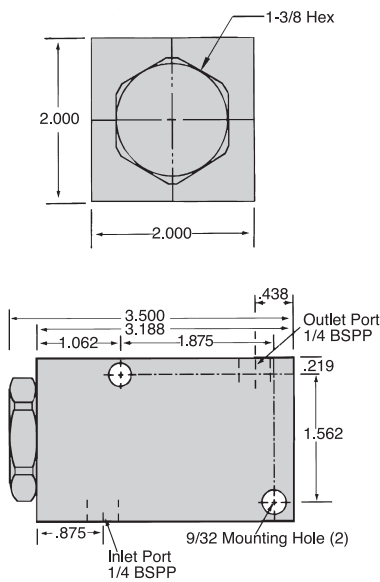

- Replaceable filter elements
- Simple and compact in design
- Easy to install on any new or existing system
- Do not use NPT fittings

OPERATION: Install the filter in the output line of the pump to provide filtration of the oil entering the system. The oil passes through the filter assembly from inlet port to outlet port.

CAUTION: Do not attempt to replace filter element with pressure in system.

Recommended mounting position is with filter body vertical, plug on the bottom. This mounting position allows contaminated filter elements to be changed without removing existing piping or tubing. Simply remove the end plug, spring, and spring retainer to get at the filter element.

CAUTION: Mounting position other than as recommended...remove entire filter assembly for servicing.

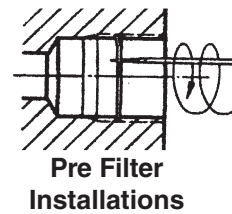

Max. Oper. Pressure (psi)	7250	7250	5000
Filter Rating (Nom. Filtration)	10 microns	10 microns	10 microns
Typical Flow Rate (cu. in./min.)	120*	230	120
Direction of Flow	Either direction	Either direction	Either direction
Material (Body)	Steel	Steel	Steel
Weight (lbs)	3	.75	1
Part No.	CLR-000-V	CLR-100-V	CLR-3887-087
Part No. of Filter Element	CLR-001-FIL	CLR-100-FIL	CLR-3887-061-FIL
Part No. of Pre-Filter	—	CLR-3887-009-FIL	—

*AP 35 psi across filter



Carr Lane Roemheld Mfg. Co.
 Sales — Phone (314) 647-6200 Fax (314) 647-5736
 Engineering — Phone 1-800-827-2526 Web roemheld-usa.com

Accessories

Fixture Hose

Standard Hose



Standard Hose with
Stainless Steel Armor Casing*



For stainless steel armor casing add "A"
at the end of the part number.
Example: CLR-HH-156-016-5J5JA

*Only available in 16 inch lengths and up.

Small-Diameter high-pressure hose perfect for workholding applications. Abrasion and chemical resistant outer cover with seamless nylon inner sleeve reinforced with synthetic yarn. Other lengths and diameters available upon request.

Nominal ID	0.156 in
Nominal OD	0.34 in
Min. bend radius	1.6 in
Burst pressure	25,520 psi
Temperature range	-40 to +150°F

Length	End Type
	#5 JIC
Part No., 9 inch	CLR-HH-156-009-5J5J
Part No., 12 inch	CLR-HH-156-012-5J5J
Part No., 15 inch	CLR-HH-156-015-5J5J
Part No., 18 inch	CLR-HH-156-018-5J5J
Part No., 24 inch	CLR-HH-156-024-5J5J

Tubing	Heavy-Duty Hose	Hydraulic Fluid																																																							
 <p style="text-align: center;">Steel Tubing</p> <p>Seamless heavy-wall tubing. C1010 steel, cold drawn, fully annealed 1/4", 5/16" and 3/8" OD available. Do not use any other type of tubing. See next page for installation guidelines and tools (CLR-300-TL flaring tool is strongly recommended).</p> <table border="1" style="width: 100%; border-collapse: collapse;"> <thead> <tr> <th>Part No.</th> <th>O.D.</th> <th>Wall Thickness</th> <th>Length*</th> </tr> </thead> <tbody> <tr><td>CLR-TC-2500-049-060</td><td>1/4"</td><td>0.049"</td><td>60"</td></tr> <tr><td>CLR-TC-3125-065-060</td><td>5/16"</td><td>0.065"</td><td>60"</td></tr> <tr><td>CLR-TC-3750-065-060</td><td>3/8"</td><td>0.065"</td><td>60"</td></tr> </tbody> </table> <p>*Custom lengths available on request</p>	Part No.	O.D.	Wall Thickness	Length*	CLR-TC-2500-049-060	1/4"	0.049"	60"	CLR-TC-3125-065-060	5/16"	0.065"	60"	CLR-TC-3750-065-060	3/8"	0.065"	60"	 <p>High-pressure hydraulic hose. 1/4" inside diameter. Reinforced with four plies of high-tensile wire, for remarkably little expansion under pressure. Fluid required due to expansion is only .066 cu. in. per foot at 7500 psi. 5" minimum bend radius. Two female ends, 5/16 JIC 37° flare, or straight tube ends for use with compression fittings.</p> <p style="text-align: center;">NOTE! 10'-0" MAXIMUM RECOMMENDED LENGTH</p> <table style="width: 100%;"> <thead> <tr> <th></th> <th>JIC 37° flare</th> <th>Compression Type</th> </tr> </thead> <tbody> <tr><td>18"</td><td>CLR-18-H</td><td>CLR-18-H-CC</td></tr> <tr><td>24"</td><td>CLR-24-H</td><td>CLR-24-H-CC</td></tr> <tr><td>30"</td><td>CLR-30-H</td><td>CLR-30-H-CC</td></tr> <tr><td>36"</td><td>CLR-36-H</td><td>CLR-36-H-CC</td></tr> <tr><td>42"</td><td>CLR-42-H</td><td>CLR-42-H-CC</td></tr> <tr><td>48"</td><td>CLR-48-H</td><td>CLR-48-H-CC</td></tr> <tr><td>60"</td><td>CLR-60-H</td><td>CLR-60-H-CC</td></tr> <tr><td>72"</td><td>CLR-72-H</td><td>CLR-72-H-CC</td></tr> </tbody> </table> <p style="text-align: center;">(Special lengths available)</p>		JIC 37° flare	Compression Type	18"	CLR-18-H	CLR-18-H-CC	24"	CLR-24-H	CLR-24-H-CC	30"	CLR-30-H	CLR-30-H-CC	36"	CLR-36-H	CLR-36-H-CC	42"	CLR-42-H	CLR-42-H-CC	48"	CLR-48-H	CLR-48-H-CC	60"	CLR-60-H	CLR-60-H-CC	72"	CLR-72-H	CLR-72-H-CC	 <p>Roemheld Hydraulic oils are compounded from premium, paraffinic base oils, plus a thermally stable zinc additive system that affords improved anti-wear and hydrolytic stability while maintaining superior oxidation stability. Use only ROEMHELD oil or an exact equivalent. FLUID MUST BE CLEAN (10 micron or better nominal filtration) See also high pressure in-line filters.</p> <table border="1" style="width: 100%; border-collapse: collapse;"> <thead> <tr> <th>Part No.</th> <th>ISO GRADE</th> <th>Container Size</th> </tr> </thead> <tbody> <tr><td>CLR-22-FL</td><td>22</td><td>1 gal.</td></tr> <tr><td>CLR-32-FL</td><td>32</td><td>1 gal.</td></tr> <tr><td>CLR-46-FL</td><td>46</td><td>1 gal.</td></tr> </tbody> </table>	Part No.	ISO GRADE	Container Size	CLR-22-FL	22	1 gal.	CLR-32-FL	32	1 gal.	CLR-46-FL	46	1 gal.
Part No.	O.D.	Wall Thickness	Length*																																																						
CLR-TC-2500-049-060	1/4"	0.049"	60"																																																						
CLR-TC-3125-065-060	5/16"	0.065"	60"																																																						
CLR-TC-3750-065-060	3/8"	0.065"	60"																																																						
	JIC 37° flare	Compression Type																																																							
18"	CLR-18-H	CLR-18-H-CC																																																							
24"	CLR-24-H	CLR-24-H-CC																																																							
30"	CLR-30-H	CLR-30-H-CC																																																							
36"	CLR-36-H	CLR-36-H-CC																																																							
42"	CLR-42-H	CLR-42-H-CC																																																							
48"	CLR-48-H	CLR-48-H-CC																																																							
60"	CLR-60-H	CLR-60-H-CC																																																							
72"	CLR-72-H	CLR-72-H-CC																																																							
Part No.	ISO GRADE	Container Size																																																							
CLR-22-FL	22	1 gal.																																																							
CLR-32-FL	32	1 gal.																																																							
CLR-46-FL	46	1 gal.																																																							



ROEMHELD
HILMA ■ STARK

Carr Lane Roemheld Mfg. Co.
Sales — Phone (314) 647-6200 Fax (314) 647-5736
Engineering — Phone 1-800-827-2526 Web roemheld-usa.com

Tubing Installation

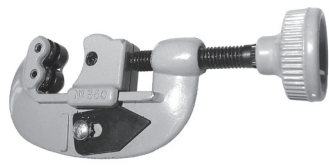

**CLR-100-TL
Tubing Cutter**

Cutting

1. Use only steel tubing as specified on the previous page.
2. Cut tubing with a tubing cutter or hacksaw.
3. File or sand tubing end square. End must be square to achieve a proper flare.



Drill Bit Deburring Tool
deburrs O.D. and I.D. simultaneously,
adjustable chamfer, 50-200 rpm

PART NO.	For Tube O.D.	Shank Ø
CLR-202-TL	1/4"	1/4"
CLR-203-TL	5/16"	5/16"
CLR-204-TL	3/8"	3/8"

**CLR-201-TL
Hand Deburring Tool**
I.D. & O.D. 1/4" - 1-1/2" pipe



Tubing Benders

PART NO.	For Tube O.D.
CLR-401-TL	1/4"
CLR-402-TL	5/16"
CLR-403-TL	3/8"

The **Roemheld** tube bender shown is a simple, effective bender we highly recommend. When bending tubing carefully avoid wrinkling, flattening or kinking the tube. Please note: complete flaring before bending.

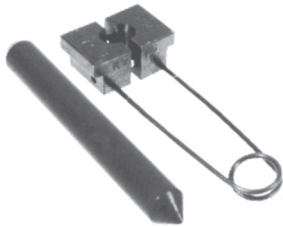

**CLR-300-TL
Flaring Tool**

Flaring

1. Place nut and sleeve over tube before flaring.
2. Place tube in flaring tool, approximately 1/8" above top of block.
3. Clamp assembled block in vise.
4. Center pin guide of flaring tool in tube.
5. Strike flaring tool 3-4 times with sharp hammer blow. Remove from block.
6. Inspect flare so that their outside diameters extend beyond the inner lip of the sleeve, but not beyond the sleeve's OD.

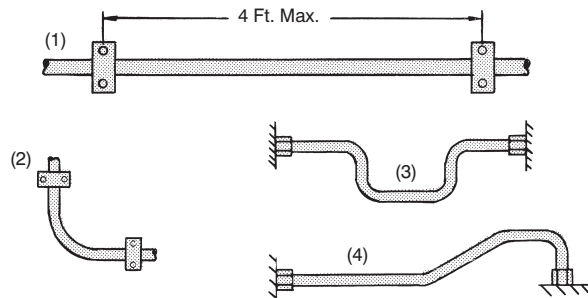
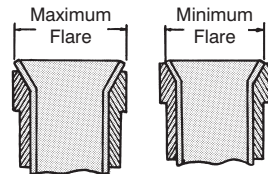

Installation

We recommend using tubing clamps as this will increase the life of the installation. Tubing clamps should be less than four feet apart (Figure 1) and bends should be supported also (Figure 2). Use bends as shown in Figures 3 and 4 instead of straight-line connections to prevent stressing the tubing.

Important: Never use tubing lines as handles to lift fixtures.

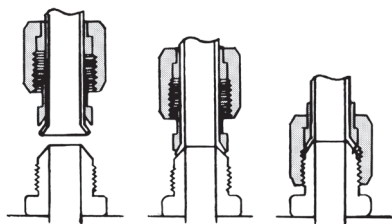

Assembly

1. Slide nut and sleeve on to flared tubing end and finger tighten.
2. Finish tightening with a wrench, 1/4 to 1/2 turn.

Note: Do not over torque.

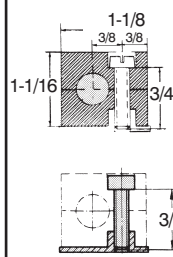

**Single Tube
Regular and Stack Mounting**

- CLR-3300-892-TA Single clamp
- CLR-3300-600-TA Single mounting plate
- CLR-3300-225-TA Mounting screw
- CLR-3300-604-TA Stack-mounting screw
- CLR-3300-335-TA Stack-mounting clip

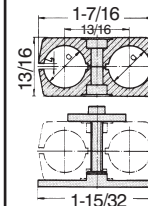





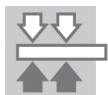







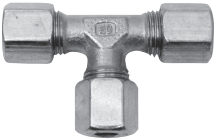

**Twin Tubes
Regular and Stack Mounting**

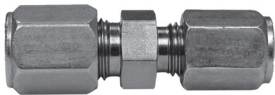
- CLR-3300-891-TA Twin clamp
- CLR-3300-607-TA Twin mounting plate
- CLR-3300-609-TA Washer
- CLR-3300-225-TA Mounting screw
- CLR-3300-613-TA Stack-mounting screw
- CLR-3300-615-TA Stack-mounting clip

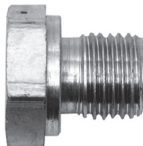

Fittings

Hydraulic Compression Fittings (7250 psi static)											
Port Fitting - Male		Banjo Elbow			Branch Tee			Union			
											
5/16 Tubing	G 1/4	CLR-802-F				5/16 Tubing	G 1/4	CLR-804-F	5/16 Tubing	CLR-701-F	
	G 1/8	CLR-805-F					G 1/4	CLR-803-F		G 1/4	CLR-824-F
1/4 Tubing	G 1/4	CLR-806-F	5/16 Tubing	G 1/4	CLR-803-F	1/4 Tubing	G 1/4	CLR-824-F	1/4 Tubing	CLR-721-F	
	G 1/8	CLR-826-F	1/4 Tubing	G 1/4	CLR-823-F**						
Elbow		Tee			Cross			Stand Pipe Union			
											
5/16 Tubing		CLR-702-F	5/16 Tubing		CLR-703-F	5/16 Tubing		CLR-704-F	5/16 Tubing	G 1/4	CLR-9208-018-F
	1/4 Tubing			1/4 Tubing			CLR-723-F*	1/4 Tubing			
Nut		Sleeve			Tube Adaptor			Port Reducer			
											
5/16 Tubing		CLR-800-F	5/16 Tubing		CLR-801-F	1/4 tube to 5/16 tube	CLR-606-F		G1/4 to G1/8	CLR-3613-003-F	
	1/4 Tubing			1/4 Tubing						CLR-821-F	G1/2 to G1/4
Air-Vent Fittings 250 psi air											
Barbed for 3/16 ID Hose		Barbed for 1/4 ID Hose			Vent Fitting			Vent Fitting - Metal Filter			
											
M5 Port		CLR-805-AF	M5 Port		CLR-3890-091-AF	G1/4 Port	CLR-817-AF		G1/8 Port	CLR-0361-012-F	
	G1/4 Port		G1/8 Port		CLR-806-AF				G1/4 Port	CLR-0361-000-F	
		CLR-815-AF	G1/4 Port		CLR-3890-093-AF				G1/2 Port	CLR-0361-006-F	

*Max 6600 psi

**Max 6000 psi











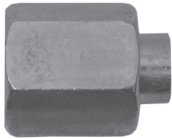

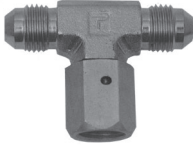
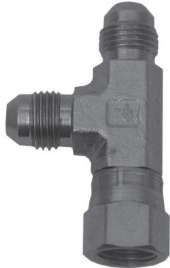

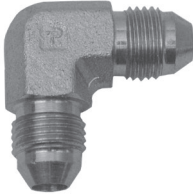

Subject to change. For further details, including detailed dimensions and mounting instructions, visit roemheld-usa.com.

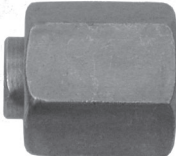

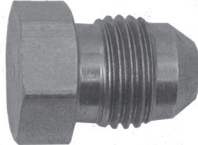
ROEMHELD
HILMA ■ STARK

Carr Lane Roemheld Mfg. Co.
Sales — Phone (314) 647-6200 Fax (314) 647-5736
Engineering — Phone 1-800-827-2526 Web roemheld-usa.com

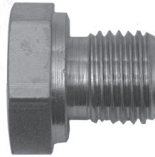
Fittings

Hydraulic 37° Flare Fittings (7250 psi static)								
Tube End		Nut Elbow		Branch Tee		Run Tee		
								
5/16 Tubing	CLR-400-F	5/16 Tubing	CLR-402-F	5/16 Tubing	CLR-403-F	5/16 Tubing	CLR-404-F	
1/4 Tubing	CLR-420-F	1/4 Tubing	CLR-422-F	1/4 Tubing	CLR-423-F	1/4 Tubing	CLR-424-F	
Union		Elbow		Tee		Cross		
 Male								
 Female (1.75 in. Flare to Flare)								
5/16 Tubing	Male	CLR-301-F	5/16 Tubing	CLR-302-F	5/16 Tubing	CLR-303-F	5/16 Tubing	CLR-304-F
1/4 Tubing	Male	CLR-321-F	1/4 Tubing	CLR-322-F	1/4 Tubing	CLR-323-F	1/4 Tubing	CLR-324-F
5/16 Tubing	Female	CLR-401-F	5/16 Tubing	CLR-402-F	5/16 Tubing	CLR-403-F	5/16 Tubing	CLR-404-F
1/4 Tubing	Female	CLR-421-F	1/4 Tubing	CLR-422-F	1/4 Tubing	CLR-423-F	1/4 Tubing	CLR-424-F
Cap		Port Fitting Female		Tube Plug		Nut 45		
								
5/16 Tubing	CLR-501-F	5/16 Tubing	CLR-813-F*	5/16 Tubing	CLR-502-F	5/16 Tubing	CLR-406-F	
1/4 Tubing	CLR-521-F	1/4 Tubing	CLR-815-F*	1/4 Tubing	CLR-522-F	1/4 Tubing	CLR-426-F	
Banjo Elbow		Port Fitting Male		Port Plug		Double Port		
								
5/16 Tubing	CLR-814-F	5/16 Tubing	G 1/4	CLR-807-F	G 1/8 Port	CLR-3610-263	G 1/4 Port	CLR-809-F
		5/16 Tubing	G 1/8	CLR-903-F	G 1/4 Port	CLR-810-F		
		1/4 Tubing	G 1/4	CLR-816-F*	G 1/2 Port	CLR-3610-000-F		

*Max. 6600 psi.

Fittings ■ Metric ■ F9.300

Fitting accessories ■ with 24° cone as per DIN EN ISO 8434-1 plug-type connectors ■ hydraulic pipes ■ pipe clamps

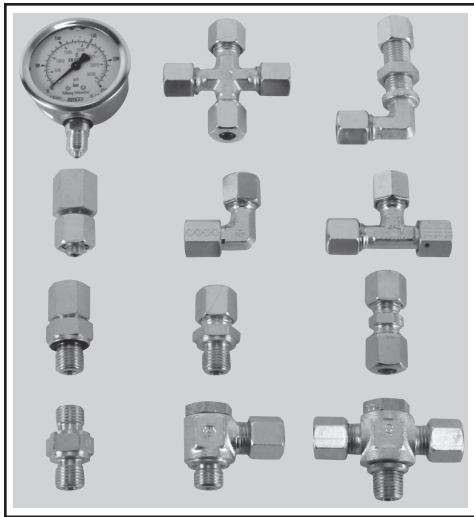

- Worldwide spread high-pressure fitting system with quadruple safety
- Leak-free connection of piping and components
- Positive and safe connection by defined and limited digging into the hydraulic pipe
- Retightening of the union nut is not required
- The fitting can be disconnected and connected again as often as required.

Tube male stud coupling with cutting ring and union nut

Before tightening

After tightening

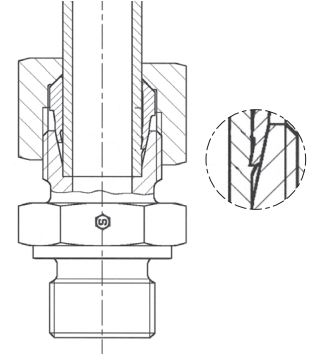

Screwed plug with knife edge

Suitable for high temperatures and aggressive media.
DIN 3852 T2 form B and EN ISO 1179-4

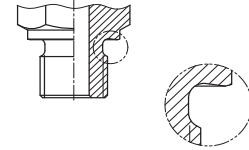

Screwed plug with elastic sealing

DIN 3852 T11 form E and EN ISO 1179-2
NBR: -35°C.....+ 100°C (series)
FKM: -25°C.....+ 200°C (available)

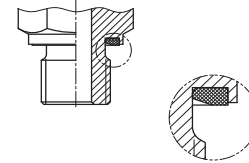

Suitable for soft mating materials (Alu).
High precision sealing (no sweating).
No retightening required.
Unlimited repeated mounting.
Interchangeable sealing ring.

Tapped hole with Whitworth pipe thread

EN ISO 1179-1 counterbore form N

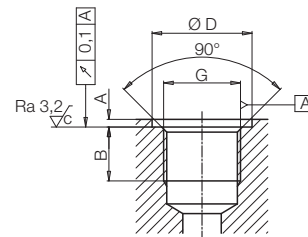

Application example

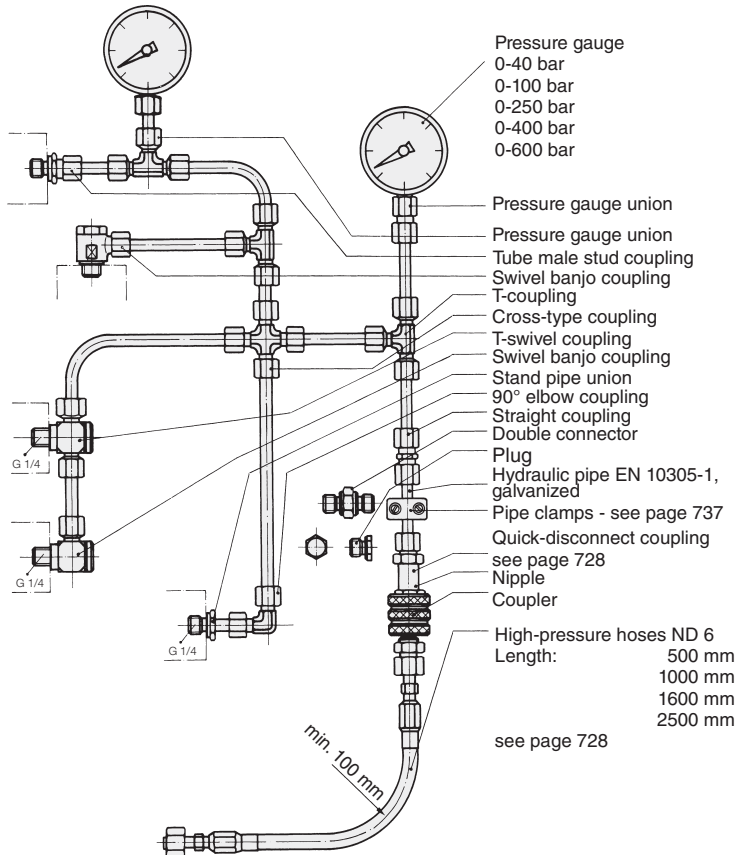

Subject to change. For further details, including detailed dimensions and mounting instructions, visit roemheld-usa.com.







ROEMHELD
HILMA ■ STARK

Carr Lane Roemheld Mfg. Co.
Sales — Phone (314) 647-6200 Fax (314) 647-5736
Engineering — Phone 1-800-827-2526 Web roemheld-usa.com

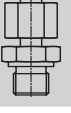
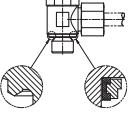
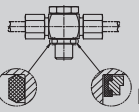
Fittings ■ Metric ■ F9.300

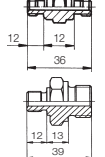
Fitting accessories ■ with 24° cone as per DIN EN ISO 8434 Plug-type connectors ■ hydraulic pipes ■ pipe clamps

Description	Pipe Ø	Screw-in threads	Type	PN [bar]	Part no.	Type	PN [bar]	Part no.
 Tube male stud coupling	6	G1/8	D6L	250	9206-003	D6L ED	250	9206-028
	8	G1/8	D8L G1/8	250	9208-034	D8L G-1/8 ED	250	9208-075
	8	G1/4	D8L	250	9208-003	D8L ED	250	9208-131
	10	G1/4	D10L	250	9210-004	D10L ED	250	9210-028
	15	G1/2	D15L	250	9215-003	D15L ED	250	9215-033
	8	G1/8	D8S G1/8	400	9208-116	D8S G-1/8 ED	500	9208-164
	8	G1/4	D8S	400	9208-102	D8S ED	630	9208-132
	10	G3/8	D10S	400	9210-104	D10S ED	630	9210-029
	16	G1/2	D16S	400	9216-004	D16S ED	500	9216-021
 Stand pipe union with sealing cone	8	G1/4	-	-	-	DCD8L	250	9208-017
	10	G1/4	-	-	-	DCD10L	250	9210-109
	8	G1/4	-	-	-	DCD8S	630	9208-018
	10	G3/8	-	-	-	DCD10S	630	9210-136
 Swivel banjo coupling	6	G1/8	SVH6LR	250	9206-004	DSVK6LROKDS	250	9206-044
	8	G1/4	SVH8LR	250	9208-004	DSVK8LROKDS	250	9208-080
	10	G1/4	SVH10LR	250	9210-015	DSVK10LROKDS	250	9210-038
	15	G1/2	SVH15LR	250	9215-004	DSVK15LROKDS	250	9215-048
	8	G1/4	SVH8SR/SA	400	9208-108	SVH8SR ED	500	9208-177
	10	G3/8	SVH10SR	315	9210-105	DSVK10SROKDS	400	9210-149
	16	G1/2	SVH16SR	250	9216-005	DSVK16SROKDS	315	9216-033
 T-swivel coupling	6	G1/8	DSVQ6LRO	250	9206-019	DSVQ6LROKDS	250	9206-048
	8	G1/4	DSVQ8LRO	250	9208-120	DSVQ8LROKDS	250	9208-169
	10	G1/4	DSVQ10LRO	250	9210-006	DSVQ10LROKDS	250	9210-154
	15	G1/2	DSVQ15LRO	250	9215-030	DSVQ15LROKDS	250	9215-050
	8	G1/4	DSVQ8SR/SA	400	9208-115	DSVQ8SR ED	500	9208-178
	10	G3/8	DSVQ10SRO	315	9210-107	DSVQ10SROKDS	400	9210-153
	16	G1/2	DSVQ16SRO	315	9216-007	DSVQ16SROKDS	315	9216-035
 Plug	-	G1/8	VSDG 1/8 A	400	3610-047	VSG 1/8 ED	400	3610-158
	-	G1/4	VSDG 1/4 A	400	3300-821	VSG 1/4 ED	400	3610-191
	-	G3/8	VSDG 3/8 A	400	3610-100	VSG 3/8 ED	400	3610-099
	-	G1/2	VSDG 1/2 A	400	3610-045	VSG 1/2 ED	400	3610-098
	-	G1/8	SW 14x7 high	400	-	SW 14x7 high	500	3610-263
	-	G1/4	SW 19x8 high	400	-	SW 19x8 high	500	3610-264
	-	G1/2	SW 27x11 high	400	-	SW 27x11 high	500	3610-265
 Thread reducing adaptor	-	G3/8	GWR 3/8-1/4	400	3613-016	GWR 3/8 ED-1/4	400	3613-073
	-	G1/2	GWR 1/2-1/4	315	3613-015	GWR 1/2 ED-1/4	400	3613-055
	-	G1/2	GWR 1/2-3/8	315	3613-018	GWR 1/2 ED-3/8	400	3613-074
 Double connector	-	G1/4 – G1/4	-	400	3610-037	-	500	3610-261
	-	G1/4 – G1/2	-	400	3610-062	-	500	3610-262
 Elastic sealing for screwed plug form E	-	G1/8	ED10X1-G1/8	630	3002-253	ED10X1-G1/8	630	3002-253
	-	G1/4	ED14X1,5-G1/4	630	3002-142	ED14X1,5-G1/4	630	3002-254
	-	G3/8	ED G3/8	630	3002-256	ED G-3/8	630	3002-257
	-	G1/2	ED G1/2	500	3002-258	ED G-1/2	500	3002-259
 KDS sealing ring for swivel banjo couplings (...KDS)	-	G1/8	KDS10	250	3002-260	KDS10	250	3001-766
	-	G1/4	KDS14	400	3002-261	KDS14	400	3001-765
	-	G3/8	KDS16	400	3002-262	KDS16	400	3002-323
	-	G1/2	KDS22	315	3002-263	KDS22	315	3002-324

Subject to change. For further details, including detailed dimensions and mounting instructions, visit roemheld-usa.com.



Carr Lane Roemheld Mfg. Co.
Sales — Phone (314) 647-6200 Fax (314) 647-5736
Engineering — Phone 1-800-827-2526 Web roemheld-usa.com

Fittings ■ Metric ■ F9.300

Fitting accessories ■ with 24° cone as per DIN EN ISO 8434 Plug-type connectors ■ hydraulic pipes ■ pipe clamps

Description	Pipe Ø	Union nut	Type	PN [bar]	Part no.
Straight coupling 	6	M 12 x 1.5	E6L	250	9206-007
	8	M 14 x 1.5	E8L	250	9208-007
	10	M 16 x 1.5	E10L	250	9210-007
	15	M 22 x 1.5	E15L	250	9215-007
	8	M 16 x 1.5	E8S	630	9208-106
	10	M 18 x 1.5	E10S	630	9210-108
	16	M 24 x 1.5	E16S	500	9216-008

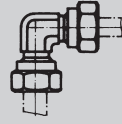
Description	Pipe Ø	Union nut	Type	PN [bar]	Part no.
90° elbow coupling 	6	M 12 x 1.5	K6L	250	9206-008
	8	M 14 x 1.5	K8L	250	9208-008
	10	M 16 x 1.5	K10L	250	9210-008
	15	M 22 x 1.5	K15L	250	9215-008
	8	M 16 x 1.5	K8S	630	9208-107
	10	M 18 x 1.5	K10S	630	9210-112
	16	M 24 x 1.5	K16S	500	9216-009

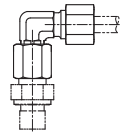
Description	Pipe Ø	Union nut	Type	PN [bar]	Part no.
Standpipe elbow with sealing cone 	8	M 14 x 1.5	KED8L	250	9208-038
	8	M 16 x 1.5	KED8S	630	9208-036

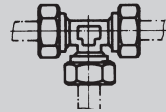
Description	Pipe Ø	Union nut	Type	PN [bar]	Part no.
T-coupling 	6	M 12 x 1.5	Q6L	250	9206-009
	8	M 14 x 1.5	Q8L	250	9208-009
	10	M 16 x 1.5	Q10L	250	9210-009
	15	M 22 x 1.5	Q15L	250	9215-009
	8	M 16 x 1.5	Q8S	630	9208-108
	10	M 18 x 1.5	Q10S	630	9210-113
	16	M 24 x 1.5	Q16S	500	9216-010

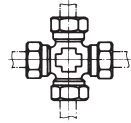
Description	Pipe Ø	Union nut	Type	PN [bar]	Part no.
Cross-type coupling 	6	M 12 x 1.5	KV6L	250	9206-011
	8	M 14 x 1.5	KV8L	250	9208-010
	10	M 16 x 1.5	KV10L	250	9210-010
	15	M 22 x 1.5	KV15L	250	9215-010
	8	M 16 x 1.5	KV8S	630	9208-109
	10	M 18 x 1.5	KV10S	630	9210-114
	16	M 24 x 1.5	KV16S	400	9216-011

Description	Pipe Ø	Union nut	Type	PN [bar]	Part no.
Straight bulk head fitting 	6	M 12 x 1.5	R6L	250	9206-026
	8	M 14 x 1.5	R8L	250	9208-023
	10	M 16 x 1.6	R10L	250	9210-117
	15	M 22 x 1.5	R15L	250	9215-022
	8	M 16 x 1.5	R8S	630	9208-117
	10	M 18 x 1.5	R10S	630	9210-119
	16	M 24 x 1.5	R16S	500	9216-017

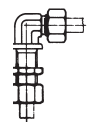
Description	Pipe Ø	Union nut	Type	PN [bar]	Part no.
90° elbow bulk head fitting 	6	M 12 x 1.5	U6L	250	9206-014
	8	M 14 x 1.5	U8L	250	9208-029
	10	M 16 x 1.5	U10L	250	9210-110
	15	M 22 x 1.5	U15L	250	9215-018
	8	M 16 x 1.5	U8S	630	9208-018
	10	M 18 x 1.5	U10S	630	9210-027
	16	M 24 x 1.5	U16S	500	9216-020

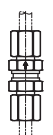
Description	Pipe Ø	Union nut	Type	PN [bar]	Part no.
Check valve, poppet type 	6	M 12 x 1.5	RWD6L	250	9206-012
	8	M 14 x 1.5	RWD8L	250	9208-012
	10	M 16 x 1.5	RWD10L	250	9210-012
	15	M 22 x 1.5	RWD15L	250	9215-011
	8	M 16 x 1.5	RWD8S	400	9208-111
	10	M 18 x 1.5	RWD10S	400	9210-116
	16	M 24 x 1.5	RWD16S	400	9216-012

Description	Pipe Ø	Union nut	Type	PN [bar]	Part no.
Union nut 	6	M 12 x 1.5	m6L	250	9206-001
	8	M 14 x 1.5	m8L	250	9208-001
	10	M 16 x 1.5	m10L	250	9210-002
	15	M 22 x 1.5	m15L	250	9215-001
	8	M 16 x 1.5	m8S	630	9208-100
	10	M 18 x 1.5	m10S	630	9210-102
	16	M 24 x 1.5	m16S	500	9216-002

Description	Pipe Ø	Type	PN [bar]	Part no.
Cutting ring 	6	s6L	250	9206-002
	8	s8L/S	250	9208-101
	10	s10L/S	250	9210-103
	15	s15L	250	9215-002
	8	s8L/S	630	9208-101
	10	s10L/S	630	9210-103
	16	s16S	500	9216-003

Description	Pipe Ø	Type	PN [bar]	Part no.
Blanking plug 	6	VB6S	630	9206-023
	8	VB8S	630	9208-039
	10	VB10S	630	9210-024
	15	VB15L	250	9215-031
	16	VB16S	500	9216-016

Description	Pipe Ø	PN [bar]	Part no.
Hydr. pipe galvanized as per EN 10305-1 	8x1	250	3128-112
	8x1.5	400	3128-113
	8x2	500	3128-212
	10x1	200	3128-114
	15x1.5	200	3128-119

Available lengths 1.5 or 3.0 m

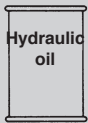
Description	Volume	PN [bar]	Part no.
Hydraulic oil as per DIN 51524-2 (max. 120 °C) 	HLP 22	1 L	9892-001
		5 L	9893-001
		10 L	9894-001
	HLP 32	1 L	9895-001
		5 L	9891-001
		10 L	9899-001
	HLP 46	1 L	9896-001
		5 L	9897-001
		10 L	9898-001

Description	Volume	PN [bar]	Part no.
Fire-resistant hydraulic liquids Oemeta HF-Du (max. 200 °C)	1 L		9892-002
	5 L		9893-002
	10 L		9894-002

Subject to change. For further details, including detailed dimensions and mounting instructions, visit roemheld-usa.com.



ROEMHELD
HILMA ■ STARK

Carr Lane Roemheld Mfg. Co.
Sales — Phone (314) 647-6200 Fax (314) 647-5736
Engineering — Phone 1-800-827-2526 Web roemheld-usa.com

Fittings ■ Metric ■ F9.300

Fitting accessories ■ with 24° cone as per DIN EN ISO 8434 Plug-type connectors ■ hydraulic pipes ■ pipe clamps

Mounting torques for tube male stud couplings and swivel banjo couplings

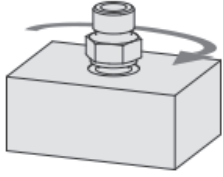

Body material: Steel lubricated
Aluminum -15%

Series	Fitting Pipe OD	Thread	Mounting torque [Nm]			
			Screwed plug with		Swivel banjo couplings	
			Knife edge	Sealing ring	Knife edge	KDS ring
L	6	G1/8	18	18	18	18
L	8	G1/4	35	35	45	40
L	10	G1/4	35	35	45	40
L	15	G1/2	140	90	120	90
S	8	G1/4	55	55	45	40
S	10	G3/8	90	80	70	65
S	16	G1/2	130	115	120	110

Single pipe clamps

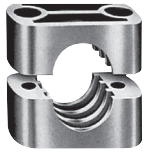

Material: polyamide
Depth: 30 mm
Fixing Screws: M6

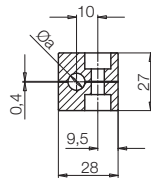

Clamp Size 1

Pipe Ø a (mm)	Part no.
8	3300-892
10	3300-893
12	3300-895

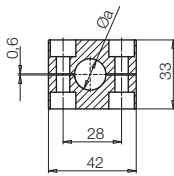

Clamp Size 2

Pipe Ø a (mm)	Part no.
15	3300-897
16	3300-890

Twin clamp

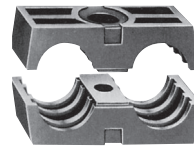

Material: polyamide
Depth: 30 mm
Fixing Screws: M6

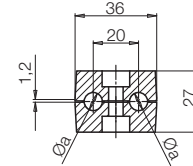

Pipe Ø a (mm)	Part no.
8	3300-891
10	3300-449

Plug-type connectors with FKM sealings for plates and piping strips (max. operating pressure 500 bar)

Short version
for connections without space

Long version
for connections with space up to 5 mm

Installation example

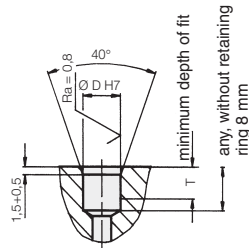
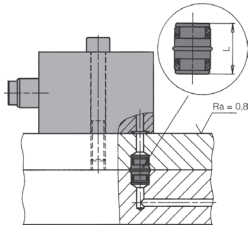

Note: max. mismatch of bore holes: short version 0.05 mm

Installation example

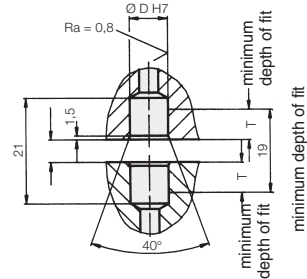
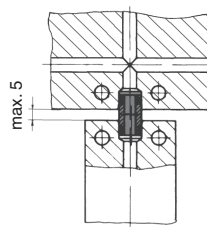

Note: max. mismatch of bore holes: short version 0.1 mm

ND	Ø D H7	L	T	Part No.
3	8	12	5.5	9210-145
5	10	14	7	9210-132

ND	Ø D H7	L	T	Part No.
5	10	19	7	9210-127

Screw plug with threaded sealing ring (max. operating pressure 500 bar)

G	G1/8	G1/4
S (mm)	8.5	12
T (mm)	8.5	12.5
SW (mm)	4	6
Part No.	0361-986	0361-987
Spare O-ring	3001-748	3000-102

Porting details

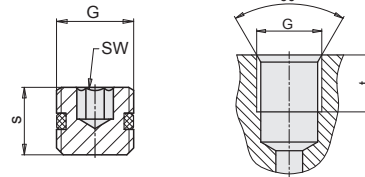

Subject to change. For further details, including detailed dimensions and mounting instructions, visit roemheld-usa.com.



Carr Lane Roemheld Mfg. Co.
Sales — Phone (314) 647-6200 Fax (314) 647-5736
Engineering — Phone 1-800-827-2526 Web roemheld-usa.com

Manifold Mounting

Benefits

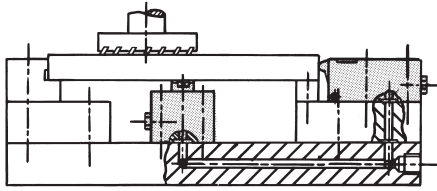

- Eliminates tubing or hoses from working area
- Very close mounting of clamps
- Only one fluid feed line
- No traps for chips due to "clean" design
- Do not use NPT fittings

Many Roemheld components can be manifold mounted... powered directly through fluid passages drilled in a fixture. This unique mounting capability eliminates tubing and hoses in the working area, for clean fixtures without chip traps. Even fluid passages longer than your drilling capacity are possible by drilling shorter passages in separate blocks, then connecting them using connecting inserts.

Perhaps most important, manifold mounting lets you put clamps and work supports closer together and in tighter spots (often letting you place more workpieces on a fixture).

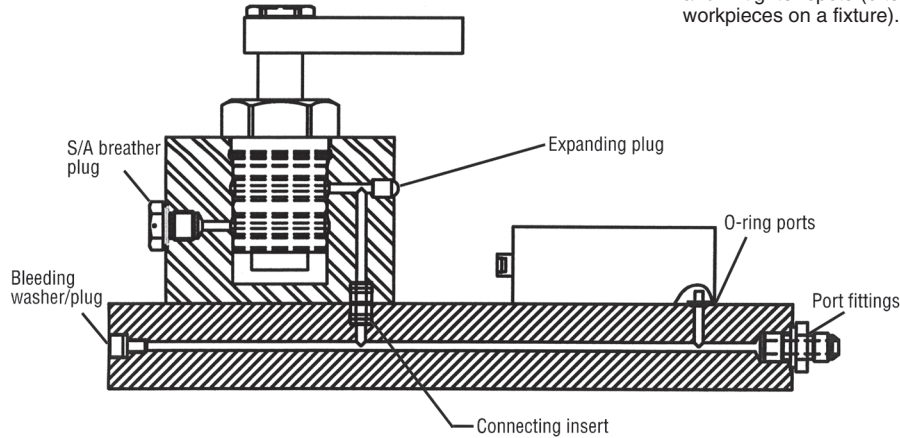

Installation Steps

Installing Threaded Body Components

For easiest installation, we recommend the following procedure (Step 1 through 6). For proper sealing, the tapped hole's bottom must be flat, with a surface finish 125 RMS or better, and perpendicular to the hole's axis. A small drill-point is allowable (see component's catalog page for dimensions). A delrin sealing washer for the hole bottom is furnished with each component. **Do not use sealing compound or teflon tape.** Part numbers to order bottoming taps:

- 1-1/4 — 16 CLR-512-TL
- 1-1/2 — 16 CLR-515-TL
- 1-7/8 — 16 CLR-518-TL

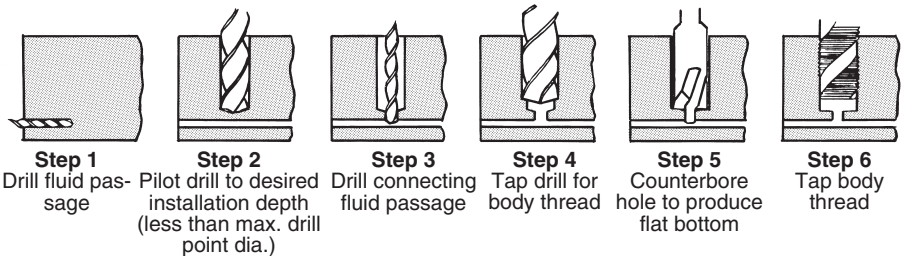

Installing Components with O-Ring Ports

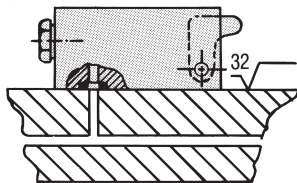

Mounting surface should be ground flat with a 32 RMS or better surface finish, so that the O-ring seals properly. Torque mounting screws evenly. **Do not use sealing compound or teflon tape.**

Order Extending Clamps, Swing Clamps, and Sequence Valves by a different part number for manifold mounting (O-rings are included, and no port plugs are needed). Edge Clamps and Block Work Supports are easily converted to manifold mounting (order o-ring CLR-3000-343-SW and CLR-810-F port plug).

Port Fittings

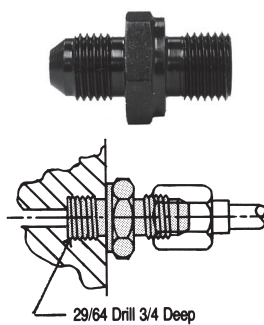

CLR-807-F
1/4 BSPP Port Fitting
Standard port fitting found in virtually all Roemheld components. To use for custom manifolds, order special bottoming tap for installation, part number CLR-514-TL. Drill, tap (5/8-inch minimum depth) and spotface. **Do not use sealing compound or teflon tape.**

CLR-902-F
1/2-20 Port Fitting
Port fitting for custom manifolds. Install using a standard 1/2-20 tap. Drill, tap (5/8-inch minimum depth) and spotface. **Do not use sealing compound or teflon tape.**



ROEMHELD
HILMA ■ STARK

Carr Lane Roemheld Mfg. Co.
Sales — Phone (314) 647-6200 Fax (314) 647-5736
Engineering — Phone 1-800-827-2526 Web roemheld-usa.com

Manifold Mounting

Benefits

Connecting Plates Together



Connecting Inserts are used to provide a leak-free connection when a fluid passage goes through two separate sections of a fixture. The insert has two O-ring seals to provide leak-free sealing. Choice of two insert lengths: short (for flush connections) and long (for connections with a gap of up to .197"). Do not use sealing compound or teflon tape. Made from steel, with FKM O-rings. **For removable plates consider flush faced coupling elements CLR-0460-735-TBC and CLR-0460-638-TBN.**

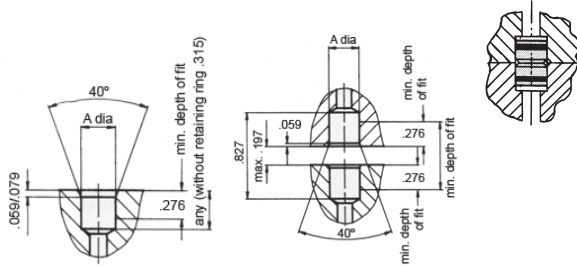

Type	Short	Long-Metric	Long-USA
Max. operating pressure	7250 psi	7250 psi	7250 psi
A dia.	.3937/.3943	.3937/.3943	.3750/.3756
Insert length	.551	.748	.748
Max. misalignment of holes	.002	.004	.004
Part No.	CLR-9210-132	CLR-9210-127-F	CLR-901-F

Plugging Drilled Passages



Expanding Plugs are used to plug the end of an oil channel. Each plug consists of a ball mounted into a sleeve which, when installed, expands and seals to the inner bore of the hole. Installation consists of preparing the hole, inserting the plug, and striking the ball to expand the sleeve. Do not use sealing compound or tape. Please consider using bleed screws instead of expanding plugs in some holes. This allows bleeding of the drilled channels.

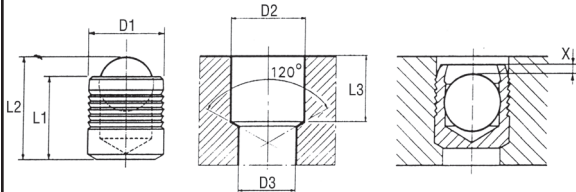

Size	1	2	3
D1	.236	.315	.394
D2 +0.004, -0.0	.236	.315	.394
D3 max.	.208	.291	.37
L1	.256	.335	.433
L2	.339	.461	.598
L3 min.	.248	.327	.425
X +/-0.008	.016	.012	.016
Part No.	CLR-916-F	CLR-906-F	CLR-926-F
Installation Tool for Expanding Plug	CLR-HT-MBM-060	CLR-HT-MBM-080	CLR-HT-MBM-100

Hydraulic Bleeding



Some drilled oil passages should have the ability to be opened for fixture bleeding. By using a sealing washer and plug, air in oil passages can be released. This is only recommended for small holes. Larger holes should be prepared to accept larger threaded plugs like CLR-810-F.

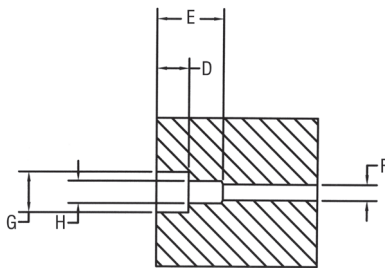

Size	1	2
D	.197	.276
E	.404	.67
F	.16	.24
G	.325	.441
H	M4	M6
Part No., Washer	CLR-3001-713-F	CLR-3000-779
Part No., Bolt	CLR-3300-357-F	CLR-3300-223-F

Air Venting - Single Acting Elements



When using Single Acting cylinders or work supports, it is important to vent the spring volume to a clean environment. If this is not done, coolant and chips can be sucked into the element during the return stroke.

Port size	G 1/8	G 1/4	G 1/2
Part No., Filter Plug	CLR-0361-012-F	CLR-0361-000-F	CLR-0361-006-F

Contact Bolts

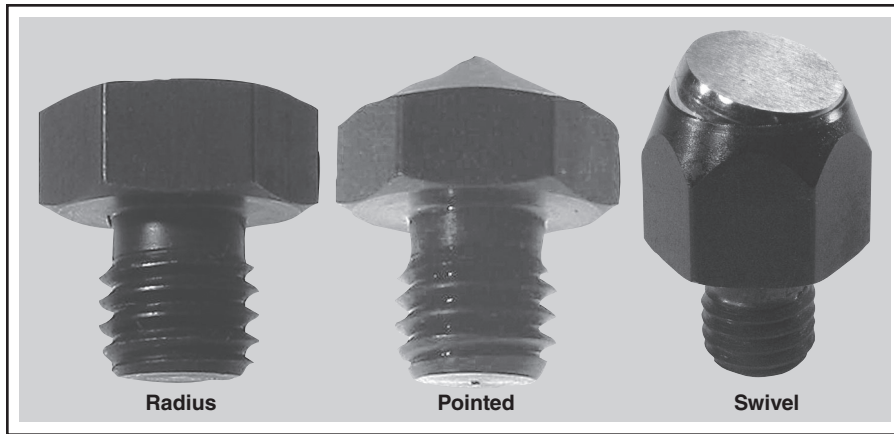

- Radius contact bolt for most applications
- Pointed contact bolt for clamping in holes, and point clamping
- Swivel contact bolt distributes clamping force to prevent marring
- 1144 steel, hardened 50-60 RC

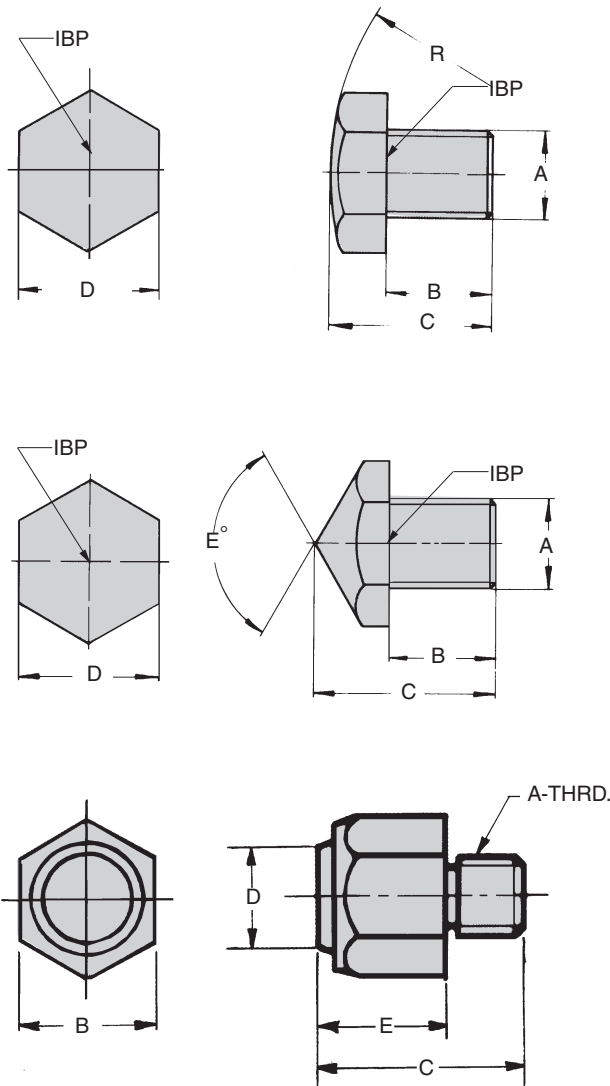

Radius

Part No.	A	B	C	D Hex	R Radius
CLR-401-CB	1/4-20	1/4	3/8	7/16	25/32
CLR-400-CB		3/8	25/32		
CLR-404-CB	5/16-18	5/16	1/2	1/2	1
CLR-402-CB		3/8	25/32		25/32
CLR-403-CB	3/8-16	1/2	7/8	9/16	1-3/8
CLR-405-CB	1/2-13	1/2	7/8	3/4	1-3/4
CLR-406-CB	5/8-11	25/32	1-3/16	15/16	2-3/8
CLR-408-CB	3/4-10	1	1-3/8	1-1/8	2-3/8
CLR-409-CB	1-8	1-3/16	1-27/32	1-1/2	3-15/16
CLR-3614-027-CB	M5	.35	.75	8mm	.79
CLR-3614-039-CB*	M6	.24	.37	10mm	.79
CLR-3614-016-CB		.39	.79		
CLR-3614-038-CB*	M8	.31	.51	13mm	.98
CLR-3614-001-CB		.39	.79		
CLR-3614-002-CB	M10	.47	.87	17mm	1.38
CLR-3614-028-CB	M12	.47	.87	19mm	1.77
CLR-3614-015-CB	M20	.98	1.38	30mm	2.36
CLR-3614-018-CB	M30	1.38	2.13	46mm	3.94
CLR-3614-019-CB	M42	1.77	2.80	65mm	5.51
CLR-3614-020-CB	M48	2.36	3.54	75mm	9.84

* These sizes are not heat treated.

Pointed

Part No.	A	B	C	D Hex	E°
CLR-413-CB	1/4-20	1/4	3/4	7/16	90
CLR-414-CB	3/8-16	1/2	1-1/16	9/16	90
CLR-415-CB	1/2-13	1/2	1	3/4	120
CLR-416-CB	5/8-11	25/32	1-3/8	15/16	120
CLR-417-CB	3/4-10	1	1-9/16	1-1/8	120
CLR-418-CB	1-8	1-3/16	1-31/32	1-1/2	120
CLR-3614-033-CB	M5	.35	.63	8mm	120°
CLR-3614-068-CB	M6	.24	.71	10mm	90°
CLR-3614-032-CB		.39	.87		
CLR-3614-069-CB	M8	.31	.87	13mm	90°
CLR-3614-021-CB	M10	.47	1.06	17mm	90°

Swivel

Part No.	A Dia	B Hex	C	D Dia	E
CLR-420-CB	5/16-18	9/16	.82	13/32	1/2
CLR-421-CB	3/8-16	13/16	1.29	19/32	13/16
CLR-422-CB	1/2-13	7/8	1.23	5/8	13/16
CLR-423-CB	5/8-11	1-1/16	1.61	13/16	1
CLR-3614-228-CB	M6	11mm	21mm	7.2mm	13mm
CLR-3614-072-CB	M8	11mm	21mm	7.2mm	13mm
CLR-3614-073-CB	M10	17mm	28mm	10.5mm	18mm
CLR-3614-074-CB	M12	17mm	30mm	10.5mm	18mm



ROEMHELD
HILMA ■ STARK

Carr Lane Roemheld Mfg. Co.
Sales — Phone (314) 647-6200 Fax (314) 647-5736
Engineering — Phone 1-800-827-2526 Web roemheld-usa.com

Application Example

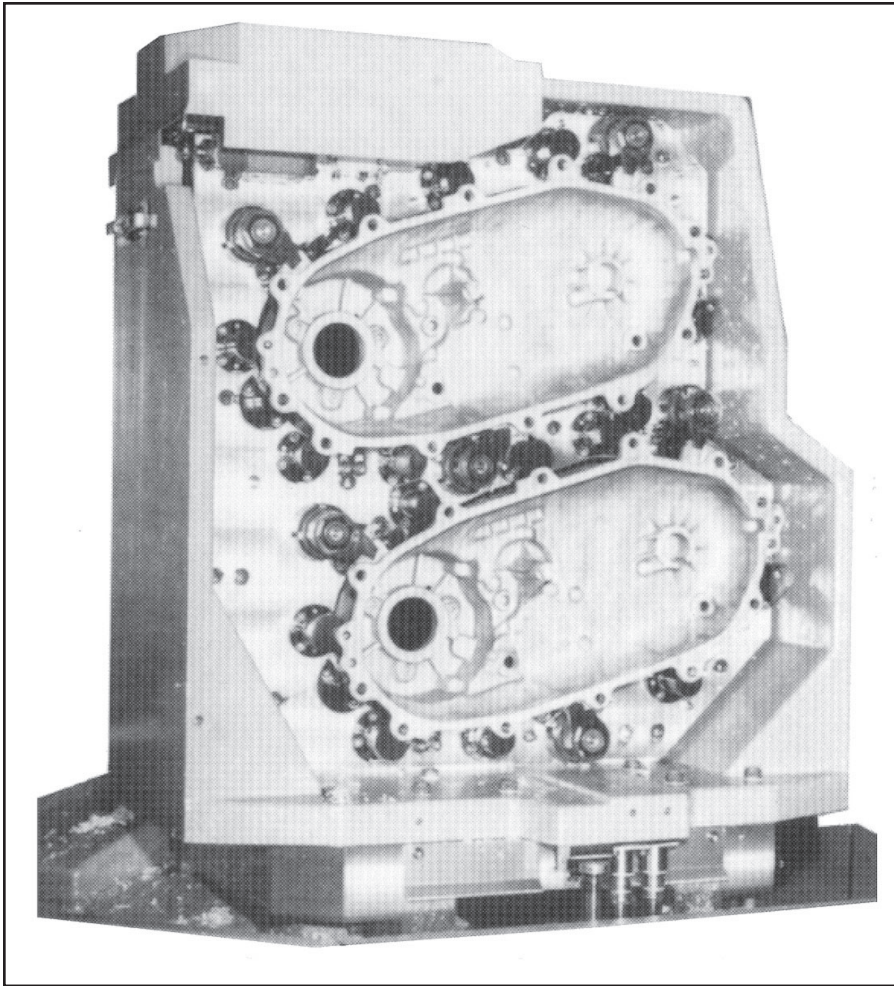

Two-sided Palletized Fixture for Machining Both Sides of an Aluminum Housing



Cartridge/Manifold-Mounted Swing Clamps
(See Swing Clamps section)



Fluid-Advanced Work Supports
(See Work Supports section)

Palletized fixture holds two aluminum castings, allowing complete machining of both sides with only one setup. The fixture uses manifold-mounted Swing Clamps and Work Supports. Fluid is supplied through passages in the vertical fixture plate, so the fixture is free of tubing lines.

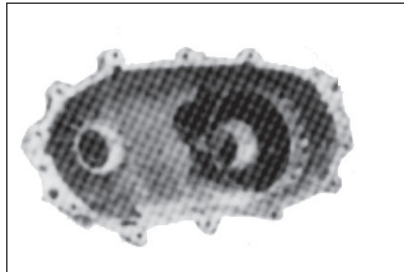
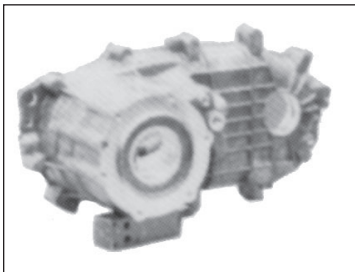

Both faces of the workpiece (above) are machined with one setup. Vertical fixture plate has cutouts (see photo at right) to allow access from both sides. Product designers integrated special clamping areas into the casting for easier fixturing.

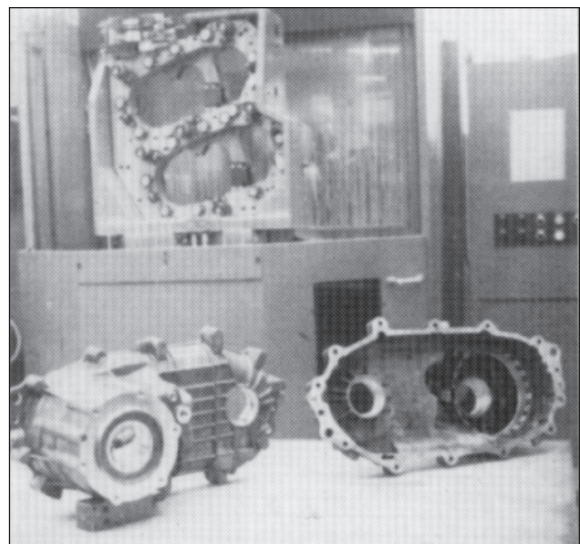

Assembly and Handling Technology

Modular Units ■ Application and combination examples

Lifting module operated by foot pedal with rotating module vertical axis



Here a complex hydraulic subassembly requires access to 5 sides during the installation of its components.

The employee can rotate the workpiece 360° in both directions about the vertical axis of this rotating module. Now the employee can select the most ergonomic position via manual or electric operation. Model versions with indexing are available too; standard index angles are 45°, 60°, 90°, 120°.

The appropriate working height is adjusted by the foot pedal of the self-contained hydraulic lifting module.

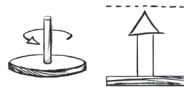

Lifting module operated by hand pendant with rotating module horizontal axis

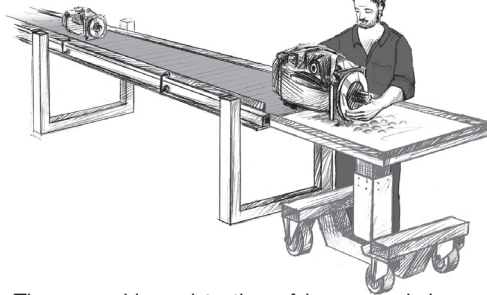

The assembly and testing of heavy workpieces such as axial piston machines is carried out at many stations. Transfer from station to station is made easy by fastening a tabletop plate to a hydraulic lift module that is mounted on top of a cart module.

Applying the brake on the cart module locks the unit in place. The operator can easily raise or lower the tabletop by pumping the foot pedal of the hydraulic lifting module.

Lifting module operated by hand pendant with rotating module horizontal axis



Multi-shift organizations know that every shift change also ushers in the change of each and every employee's size and ability. Modular combinations adapt to such changes and this one is composed of two modules: electric lift and horizontal-axis rotating. The electric lifting module effortlessly adjusts to an employee's height via a hand

or foot push-button pendant. The horizontal-axis rotating module does just what its name implies; it spins a workpiece about its horizontal axis. It has 360° of rotation in both directions. Push or pull your workpiece to rotate the version without indexing or automatically index to your next position using the hand-lever or foot-pedal versions.

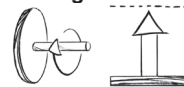

Lifting module operated by foot pedal with tilting module and rotating module vertical axis



Optimum assembly of car seats requires the ability to quickly and easily move the seat into different positions. This modular combination allows the employee to raise, lower, rotate and tilt the seat. The tilting module is equipped with a pneumatic balancer that counteracts almost all of the tilting torques. This means very little force is required of the employee to tilt heavy objects.

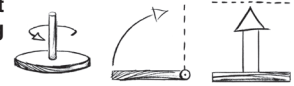

Electrically operated lifting module in sync

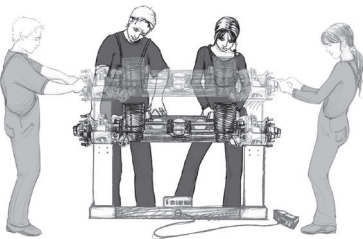

Assembly of truck axles is carried out by two employees at the same time. Components are installed and fastened from above as well as from both ends. The working height is adjusted via a foot pendant that controls two synchronized electric lifting modules. The synchronized lifts guarantee a level work surface throughout the entire stroke. The lifting modules are mounted to a floor module to improve stability.

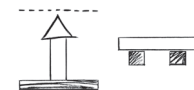

Lifting module operated by foot pedal with tilting module



Here the employee is carrying out the final assembly of an electric motor followed by a series of tests.

The working height is adjusted by the foot pedal of the hydraulic lifting module. The tilting module mounted on top of the lifting module allows the employee to tilt the motor back and forth by 90°. The integrated pneumatic-counterbalance feature makes tilting the motor a nearly effortless task.

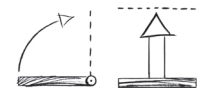

ROEMHELD
HILMA ■ STARK

Carr Lane Roemheld Mfg. Co.
Sales — Phone (314) 647-6200 Fax (314) 647-5736
Engineering — Phone 1-800-827-2526 Web roemheld-usa.com

Lifting Units

Manual-Hydraulic



- Self-contained units for lifting and height adjustment
- Single-pedal operation for sensitive, controlled lifting
- Square column resists torsional loads
- Choice of five stroke lengths, up to 23.62 inches
- To descend the lifting unit a maximum of 10% of Fz max. load is required
- The center of gravity should be within the traverse of the mounting bolts

OPERATION: Raise and lower unit using the same lever. Pump foot lever down 45 degrees to raise platform. To lower unit, lift lever 10 degrees to release pressure.

PRESSURE RELIEF: If pumping continues after reaching full height extension, pressure relieves automatically and returns fluid to the reservoir.

MOUNTING: Tapped holes in top and bottom plates allow attaching custom bases and tables.

CONSTRUCTION: Square column is made from anodized aluminum. Top and bottom mounting plates are black anodized aluminum. The operating lever is steel with bright zinc plating, with a molded plastic foot pedal.

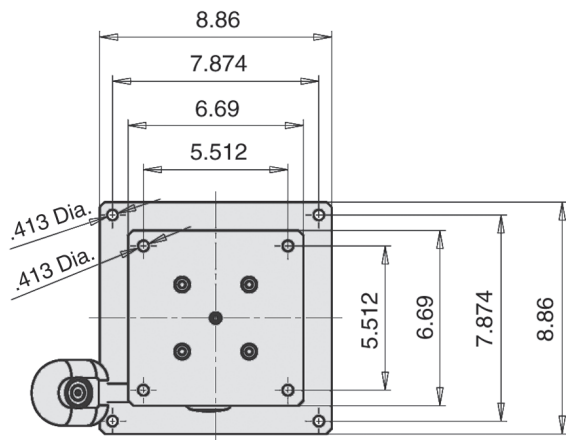

MAXIMUM TORQUE LOAD: In the case of eccentric loads, it is recommended to compensate these by counterweights. In off-position the indicated maximum torques may occur.

The forces and torques have to be considered by the operator. During the lifting motion only 50% of the maximum values are admitted.

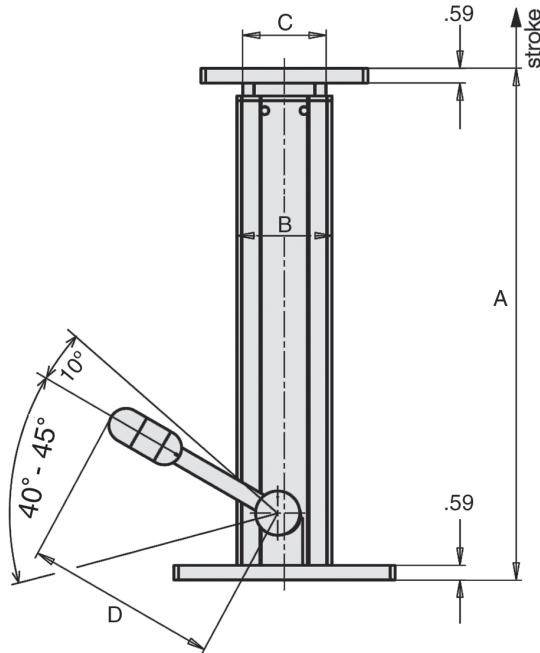
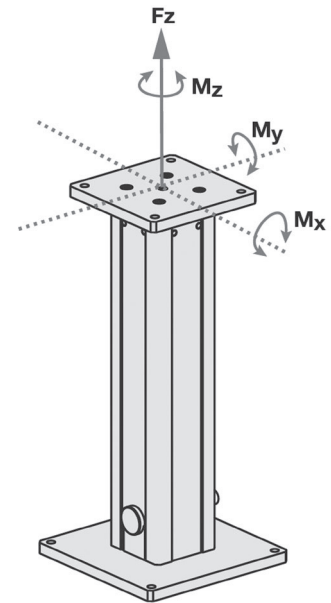

Fz lifting capacity with centered load	225 lbs	450 lbs	900 lbs	1350 lbs	1350 lbs	
Pump motions per 3.94 in. of stroke	8	8	8	10	10	
Fully Extended Height Stroke + A	Stroke	A	Stroke	A	Stroke	A
	7.87	16.54	7.87	16.54	7.87	20.47
	11.81	20.47	11.81	20.47	11.81	24.41
	15.75	24.41	15.75	24.41	15.75	28.35
	19.69	28.35	19.69	28.35	NA	NA
23.62	32.28	23.62	32.28	NA	NA	
B Sq	3.82	5.91			5.91	
C Sq	3.35	5.24			NA	
D	7.7	11.7			11.3	
Mx/y (Max. Torque Load)	74 ft. lbs.	369 ft. lbs.			590 ft. lbs.	
Mz (Max. Torque Load)	37 ft. lbs.	221 ft. lbs.			295 ft. lbs.	
Part No.	CLR-8910-01-X0-H		CLR-8915-0X-X0-H		CLR-8919-06-X0-H	
	Stroke		Max. Lift Force		Stroke	
	2=7.87		2=450 lbs.		2=7.87	
	3=11.81		4=900 lbs.		3=11.81	
	4=15.75		6=1350 lbs.		4=15.75	
	5=19.69				5=19.69	
6=23.62				6=23.62		



Carr Lane Roemheld Mfg. Co.

Sales — Phone (314) 647-6200 Fax (314) 647-5736

Engineering — Phone 1-800-827-2526 Web roemheld-usa.com

ONLINE EXCLUSIVE

THIS CARR LANE MANUFACTURING PRODUCT
IS AVAILABLE EXCLUSIVELY ONLINE.



www.carrlane.com



Our Promise of Quality

We are committed to being the world's preferred source of standard tooling components by meeting and surpassing our customers' expectations for top quality and excellent service every day.

ISO 9001:2015
CERTIFIED



INCH DRILL SIZES

Drill/Decimal	Drill/Decimal	Drill/Decimal
80 .0135	9/64 .1406	23/64 .3594
79 .0145	27 .1440	U .3680
1/64 .0156	26 .1470	3/8 .3750
78 .0160	25 .1495	V .3770
77 .0180	24 .1520	W .3860
76 .0200	23 .1540	25/64 .3906
75 .0210	5/32 .1562	X .3970
74 .0225	22 .1570	Y .4040
73 .0240	21 .1590	13/32 .4062
72 .0250	20 .1610	Z .4130
71 .0260	19 .1660	27/64 .4219
70 .0280	18 .1695	7/16 .4375
69 .0292	11/64 .1719	29/64 .4531
68 .0310	17 .1730	15/32 .4688
1/32 .0312	16 .1770	31/64 .4844
67 .0320	15 .1800	1/2 .5000
66 .0330	14 .1820	33/64 .5156
65 .0350	13 .1850	17/32 .5312
64 .0360	3/16 .1875	35/64 .5469
63 .0370	12 .1890	9/16 .5625
62 .0380	11 .1910	37/64 .5781
61 .0390	10 .1935	19/32 .5938
60 .0400	9 .1960	39/64 .6094
59 .0410	8 .1990	5/8 .6250
58 .0420	7 .2010	41/64 .6406
57 .0430	13/64 .2031	21/32 .6562
56 .0465	6 .2040	43/64 .6719
3/64 .0469	5 .2055	11/16 .6875
55 .0520	4 .2090	45/64 .7031
54 .0550	3 .2130	23/32 .7188
53 .0595	7/32 .2188	47/64 .7344
1/16 .0625	2 .2210	3/4 .7500
52 .0635	1 .2280	49/64 .7656
51 .0670	A .2340	25/32 .7812
50 .0700	15/64 .2344	51/64 .7969
49 .0730	B .2380	13/16 .8125
48 .0760	C .2420	53/64 .8281
5/64 .0781	D .2460	27/32 .8438
47 .0785	E .2500	55/64 .8594
46 .0810	1/4 .2500	7/8 .8750
45 .0820	F .2570	57/64 .8906
44 .0860	G .2610	29/32 .9062
43 .0890	17/64 .2656	59/64 .9219
42 .0935	H .2660	15/16 .9375
3/32 .0938	I .2720	61/64 .9531
41 .0960	J .2770	31/32 .9688
40 .0980	K .2810	63/64 .9844
39 .0995	9/32 .2812	1 1.0000
38 .1015	L .2900	
37 .1040	M .2950	+64th increments up to 1-7/8"
36 .1065	19/64 .2969	
7/64 .1094	N .3020	
35 .1100	5/16 .3125	
34 .1110	O .3160	+32nd increments up to 2-1/4"
33 .1130	P .3230	
32 .1160	21/64 .3281	
31 .1200	Q .3320	
1/8 .1250	R .3390	+16th increments up to 4-1/4"
30 .1285	11/32 .3438	
29 .1360	S .3480	
28 .1405	T .3580	

METRIC DRILL SIZES

Drill/Decimal	Drill/Decimal	Drill/Decimal
.35mm .0138	3.60mm .1417	8.70mm .3425
.38mm .0150	3.70mm .1457	8.75mm .3445
.40mm .0157	3.75mm .1476	8.80mm .3465
.42mm .0165	3.80mm .1496	8.90mm .3504
.45mm .0177	3.90mm .1535	9.00mm .3543
.48mm .0189	4.00mm .1575	9.10mm .3583
.50mm .0197	4.10mm .1614	9.20mm .3622
.55mm .0217	4.20mm .1654	9.25mm .3642
.60mm .0236	4.25mm .1673	9.30mm .3661
.65mm .0256	4.30mm .1693	9.40mm .3701
.70mm .0276	4.40mm .1732	9.50mm .3740
.75mm .0295	4.50mm .1772	9.60mm .3780
.80mm .0315	4.60mm .1811	9.70mm .3819
.85mm .0335	4.70mm .1850	9.75mm .3839
.90mm .0354	4.75mm .1870	9.80mm .3858
.95mm .0374	4.80mm .1890	9.90mm .3898
1.00mm .0394	4.90mm .1929	10.00mm .3937
1.05mm .0413	5.00mm .1969	10.20mm .4016
1.10mm .0433	5.10mm .2008	10.50mm .4134
1.15mm .0453	5.20mm .2047	10.80mm .4252
1.20mm .0472	5.25mm .2067	11.00mm .4331
1.25mm .0492	5.30mm .2087	11.20mm .4409
1.30mm .0512	5.40mm .2126	11.50mm .4528
1.35mm .0531	5.50mm .2165	11.80mm .4646
1.40mm .0551	5.60mm .2205	12.00mm .4724
1.45mm .0571	5.70mm .2244	12.20mm .4803
1.50mm .0591	5.75mm .2264	12.50mm .4921
1.55mm .0610	5.80mm .2283	13.00mm .5118
1.60mm .0630	5.90mm .2323	13.50mm .5315
1.65mm .0650	6.00mm .2362	14.00mm .5512
1.70mm .0669	6.10mm .2402	14.50mm .5709
1.75mm .0689	6.20mm .2441	15.00mm .5906
1.80mm .0709	6.25mm .2461	15.50mm .6102
1.85mm .0728	6.30mm .2480	16.00mm .6299
1.90mm .0748	6.40mm .2520	16.50mm .6496
1.95mm .0768	6.50mm .2559	17.00mm .6693
2.00mm .0787	6.60mm .2598	17.50mm .6890
2.05mm .0807	6.70mm .2638	18.00mm .7087
2.10mm .0827	6.75mm .2657	18.50mm .7283
2.15mm .0846	6.80mm .2677	19.00mm .7480
2.20mm .0866	6.90mm .2717	19.50mm .7677
2.25mm .0886	7.00mm .2756	20.00mm .7874
2.30mm .0906	7.10mm .2795	20.50mm .8071
2.35mm .0925	7.20mm .2835	21.00mm .8268
2.40mm .0945	7.25mm .2854	21.50mm .8465
2.45mm .0965	7.30mm .2874	22.00mm .8661
2.50mm .0984	7.40mm .2913	22.50mm .8858
2.55mm .1004	7.50mm .2953	23.00mm .9055
2.60mm .1024	7.60mm .2992	23.50mm .9252
2.65mm .1043	7.70mm .3031	24.00mm .9449
2.70mm .1063	7.75mm .3051	24.50mm .9646
2.75mm .1083	7.80mm .3071	25.00mm .9843
2.80mm .1102	7.90mm .3110	
2.90mm .1142	8.00mm .3150	+1.00mm increments up to 48mm
3.00mm .1181	8.10mm .3189	
3.10mm .1220	8.20mm .3228	
3.20mm .1260	8.25mm .3248	
3.25mm .1280	8.30mm .3268	+5.00mm increments from 50mm up to 105mm
3.30mm .1299	8.40mm .3307	
3.40mm .1339	8.50mm .3346	
3.50mm .1378	8.60mm .3386	

TAP GUIDE SIZES (Priced as specials)

Tap Size*	Tap Guide Nominal ID Size	Tap Drill Size**
#0-80	.0616	3/64
#2-56	.0883	#50
#2-64	.0880	#50
#4-40	.1152	#43
#4-48	.1147	#42
#5-40	.1282	#38
#5-44	.1280	#37
#6-32	.1421	#36
#6-40	.1412	#33
#8-32	.1681	#29
#8-36	.1676	#29
#10-24	.1954	#25
#10-32	.1941	#21
1/4-20	.2565	#7
1/4-28	.2546	#3
5/16-18	.3197	F
5/16-24	.3179	I
3/8-16	.3831	5/16
3/8-24	.3804	Q
7/16-14	.4468	U
7/16-20	.4440	25/64
1/2-13	.5100	27/64
1/2-20	.5065	29/64
9/16-12	.5733	31/64
9/16-18	.5697	33/64
5/8-11	.6368	17/32
5/8-18	.6322	37/64
3/4-10	.7630	21/32
3/4-16	.7581	11/16
7/8-9	.8894	49/64
7/8-14	.8843	13/16
1-8	1.0162	7/8
1-14	1.0093	15/16
METRIC		
M1.6x0.35	.0651	1.25mm or #55
M2x0.4	.0810	1.60mm or #52
M2.5x0.45	.1008	2.05mm or #46
M3x0.5	.1207	2.50mm or #39
M3.5x0.6	.1407	2.90mm or #32
M4x0.7	.1613	3.30mm or #30
M5x0.8	.2010	4.20mm or #19
M6x1	.2410	5.00mm or #8
M8x1.25	.3214	6.80mm or H
M8x1	.3197	7.00mm or J
M10x1.5	.4009	8.50mm or R
M10x1.25	.4002	8.80mm or 11/32
M12x1.75	.4805	10.20mm or 13/32
M12x1.25	.4789	10.80mm or 27/64
M14x2	.5600	12.00mm or 15/32
M14x1.5	.5584	12.50mm or 1/2
M16x2	.6387	14.00mm or 35/64
M16x1.5	.6372	14.50mm or 37/64
M18x2.5	.7191	15.50mm or 39/64
M18x1.5	.7159	16.50mm or 21/32
M20x2.5	.7978	17.50mm or 11/16
M20x1.5	.7946	18.50mm or 47/64
M22x2.5	.8765	19.50mm or 49/64
M22x1.5	.8734	20.50mm or 13/16
M24x3	.9583	21.00mm or 53/64
M24x2	.9537	22.00mm or 7/8
* Coarse series shown in bold. Pitch callout not required on metric coarse series.		
** Closest size for 75% theoretical thread.		

4200 Carr Lane Ct., P.O. Box 191970
St. Louis, MO 63119-7970, USA

Phone: +1.314.647.6200
Fax: +1.314.647.5736

cs@carrlane.com
www.carrlane.com



PRINTED IN USA, COPYRIGHT 2020
CARR LANE MANUFACTURING CO.