



ROLL-A-WAY

CONVEYORS, INC

Manufacturers Since 1936 

ROLL-A-WAY

CONVEYORS, INC



The Roll-A-Way Conveyor Story

In July of 1983, Payson Casters purchased Roll-A-Way, making Roll-A-Way a subsidiary of Payson. Washington-Kinney, a material handling division of Roll-A-Way in Chicago, was purchased at the same time.

Over the years, additional conveyor businesses were purchased, increasing Roll-A-Way's strength. In June of 1986, Roll-A-Way brought in Randolph Conveyor out of Chicago. American Overhead Conveyors was acquired in January of 1998, originally manufactured in Glenwood, MN.

The acquisition of these lines has proven to be a wise move. From standard conveyors and material handling products to completely customized systems, Roll-A-Way is proud to provide the products you desire, the service you expect, and the quality you deserve.

Roll-A-Way Conveyors, Inc.

2335 Delaney Road, Gurnee Illinois 60031
Phone: 847.336.5033 • Fax: 847.336.6542
www.roll-away.com • Email: Roll-a-way@roll-away.com

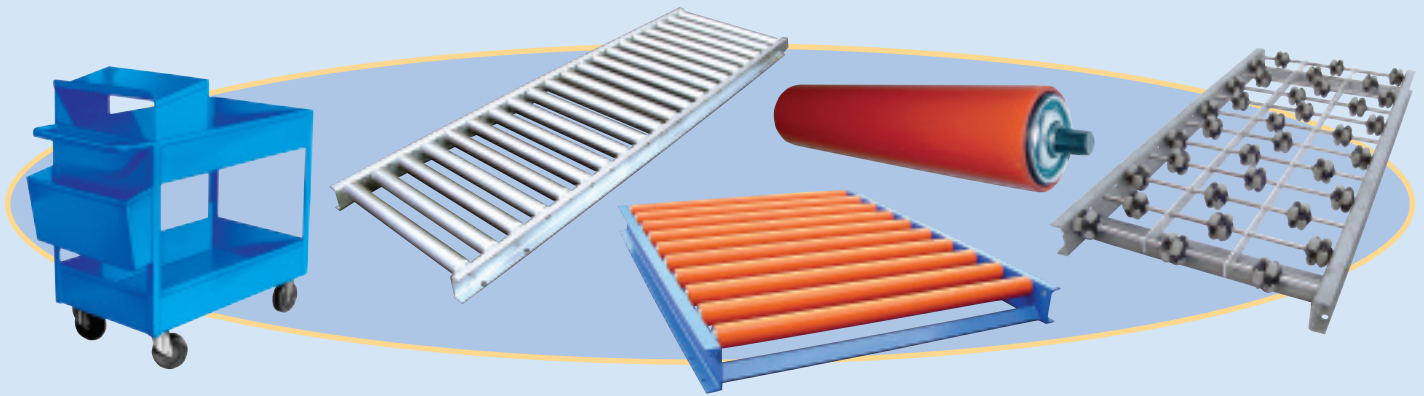

Table Of Contents

► **GRAVITY CONVEYORS**

Ball Transfer Table 4
 Ball Transfer Rails 4
 Skate Wheel Conveyors 5
 Skate Wheel Curves 6
 Skate Wheel Spurs 6
 Skate Wheels Only 6
 3/4" Micro Roller Conveyors 7
 7/8" Mini Roller Conveyors 7
 1-3/8" Roller Conveyors 8
 1-5/8" Stainless Roller Conveyors 9
 1.9" PVC Roller Conveyors 9
 1.9" & 2" Light Duty Roller Conveyors 10
 Light Duty Curves 11
 Light Duty Spurs 11
 1.9" Medium/Heavy Roller Conveyors 12
 2" Heavy Duty Roller Conveyors 13
 2-1/2" Medium Roller Conveyors 14-15
 2-1/2" Heavy Duty Roller Conveyors 14-15
 Extra Heavy Duty Roller Conveyors 16
 Medium & Heavy Duty Curves 17
 Medium & Heavy Duty Spurs 17

► **CONVEYOR ACCESSORIES**

Guard Rails 18
 Stops 18
 Rollers 18

► **CONVEYOR STANDS**

Light Duty Stands 19
 Heavy Duty Stands 19
 Super Duty Stands 19
 Tripod Stands 20
 Mobile Stands 20
 Heavy Duty V Stand 20
 Tier Stands 21
 Roller Stands 21

► **ELECTRICAL CONTROLS** 21

► **ACCORDION CONVEYORS**

(Wheel, Roller & Accessories) 22-23

► **POWER & SPECIALTY CONVEYORS**

Flo Rail Conveyors 24
 Gates 24
 Specialty Rollers 25
 Chain Driven Live Roller Conveyors 25
 Slimline & Mini-veyors 26
 Parts-veyors 26
 Slider Bed Conveyors 27
 Roller Bed Conveyors 27
 Belt Driven Live Roller Conveyors 28
 V-Belt Driven Curve Conveyors 28
 Floor-To-Floor Incline Conveyors 29
 Wire Mesh Belt Conveyors 29
 Flat-Top Chain Conveyors 30
 Multidirectional Wheel Conveyors 30

Hopper-veyors 31
 Pocket-veyors 31
 Chain-O-Flex Overhead Conveyors 32-33

► **TRUCKS, CARTS & RACKS**

Wood Deck Platform Trucks 34
 Steel & Aluminum Deck Trucks 35
 Extra Stable Drywall Truck 36
 Granite Hand Truck 36
 Super Duty Granite Truck 36
 Granite Storage Racks 36
 OP Order Picking Truck 37
 WS Warehouse Shelf Truck 37
 UT Utility Truck 37
 BM Building Material Carts 38
 Battery Stands & Carts 38
 Electronic Cabinet Dolly 38
 MT Merchandise Truck 39
 ST Selector Truck 39
 BT Bindery Truck 39
 DW Drywall Truck 40
 GT Garment Truck 40
 CT Cradle Truck 40
 Security Truck 41
 All Purpose Furniture Dolly 41
 Low Pan Truck 41
 Shop Cart 41

► **CUSTOM FABRICATION** 42

► **POWDER COATING SERVICES** 43

Warranty

Roll-A-Way Conveyor Company warrants that the workmanship and material used in the production of its products is of good quality. Roll-A-Way will, for a period of six months, replace at no cost, any part that proves to be defective. Installation shall be the responsibility of the purchaser and Roll-A-Way's liability limited only to furnishing said parts. All parts are shipped FOB Gurnee, Illinois. Roll-A-Way is not responsible for consequential damages such as delays, expenses, or loss of profit. Failure due to incorrect adjustments, abuse, damp, corrosive, or abrasive environment does not constitute failure due to defects in workmanship or materials. Component parts not manufactured by Roll-A-Way (i.e., gear reducers and motors) will be replaced or repaired at the option of the manufacturer. Contact nearest service center for all warranty claims.

Ball Transfer Table

The ball transfer table is ideal for products which must be rotated or positioned from one work station to another. Steel balls are friction-free and easily glide boxes, packages, etc. in any direction. Can be floor mounted or placed on adjustable H-stands for work-height jobs. Three separate ball styles available. Custom sizes optional: stainless steel tables, stainless or nylon ball, etc.

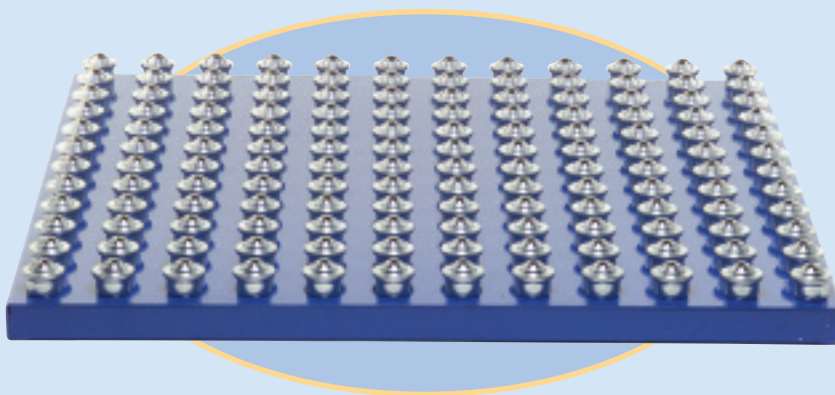

► BTT SERIES STANDARD TABLE TOP

Size In	2" SPACING		3" SPACING		4" SPACING		6" SPACING	
	Model No	Weight Lbs	Model No	Weight Lbs	Model No	Weight Lbs	Model No	Weight Lbs
24 x 24	BTT-2424-2	67	BTT-2424-3	54	BTT-2424-4	48	BTT-2424-6	35
24 x 36	BTT-2436-2	98	BTT-2436-3	73	BTT-2436-4	56	BTT-2436-6	49
24 x 48	BTT-2448-2	131	BTT-2448-3	100	BTT-2448-4	81	BTT-2448-6	67
36 x 36	BTT-3636-2	143	BTT-3636-3	110	BTT-3636-4	95	BTT-3636-6	69
36 x 48	BTT-3648-2	192	BTT-3648-3	145	BTT-3648-4	115	BTT-3648-6	91
48 x 48	BTT-4848-2	250	BTT-4848-3	189	BTT-4848-4	150	BTT-4848-6	123

Ball Options



Model 1001 (Standard)
1" ball has cap. of 65 lbs;
Stem mount
1/4-20 thread;
1-9/16" high.



Model 101 (Optional)
1" ball has cap. of 75 lbs;
1-3/16" high.



Model 201 (Optional)
1-1/2" ball has cap. of 250 lbs;
1-13/16" high.



Pan Mount (Standard)
Mounted with choice of 2, 3, 4 or 6" centers;
Material is 12 ga.
1-3/4" high.



Conveyor Mount (Optional)
Mounted with choice of 2, 3, 4 or 6" centers;
Material is 12 ga.

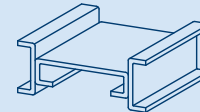

Conveyor Channel Mount (Optional)
Centers generally mounted 3, 4, or 6".
Steel thickness is 12 ga.

Ball Transfer Rails

These single-frame rails are custom designed for transfer systems. The ball transfers allow for fast change-of-load direction. Available in 5' or 10' lengths with 1" or 1-1/2" ball transfers.

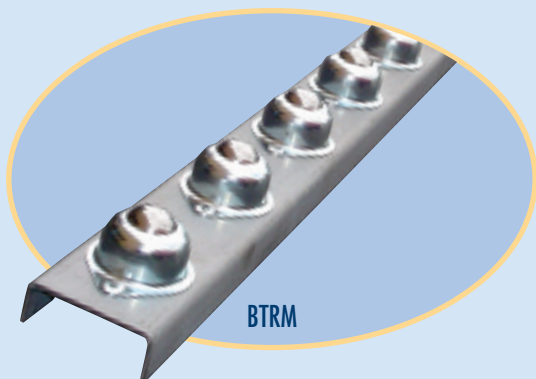

► BTR SERIES

Ball Center Spacing In	Capacity Per Ball	5 FT		10 FT	
		Model No.	Weight Lbs	Model No.	Weight Lbs
MODEL 1001 • LIGHT DUTY BALL • 2-1/2 X 1-12 GAUGE GALVANIZED CHANNEL					
3	65	BTRL-3-5	16	BTRL-3-10	31
4	65	BTRL-4-5	14	BTRL-4-10	27
6	65	BTRL-6-5	12	BTRL-6-10	23
MODEL 101 • MEDIUM DUTY BALL • 2-1/2 X 1-12 GAUGE GALVANIZED CHANNEL					
3	75	BTRM-3-5	16	BTRM-3-10	31
4	75	BTRM-4-5	14	BTRM-4-10	27
6	75	BTRM-6-5	12	BTRM-6-10	23
MODEL 201 • HEAVY DUTY BALL • 3-1/2 X 1-10 GAUGE PAINTED CHANNEL					
6	250	BTRH-6-5	25	BTRH-6-10	50
12	250	BTRH-12-5	18	BTRH-12-10	36

Skate Wheel Conveyors

Skate wheel conveyors are well suited to glide lightweight cartons and packages from one station to another. They're particularly ideal if you must set up a temporary conveyor line. Merely hook the sections together and away you go. Take note that aluminum is truly light in weight. For use in shipping, warehousing and other assembly areas. Also available with black plastic and white nylon wheels and stainless steel frames.

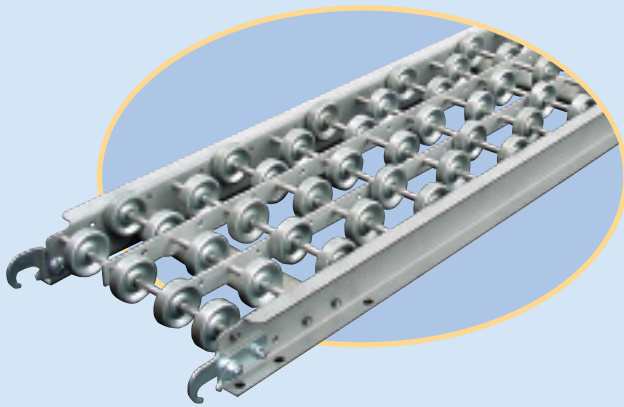

AW & SW SERIES SPECIFICATIONS:

Wheels: 2" x 5/8" Ball Bearing ♦ Axles: 1/4" on 3" Centers ♦ Frame: 2-1/2" x 1" x 1", 12 Ga. Galv. or 1/8" Alum. Formed Channel ♦ 5 Cross Braces and 2 Full Length 1" x 1/8" Alum. Center Supports ♦ Hook and Bolt Couplers Standard ♦ 10' Frame Capacity - Steel: 50lbs/ft, Alum: 30lbs/ft ♦ 5' Frame Capacity - Steel: 200lbs/ft, Alum:100lbs/ft

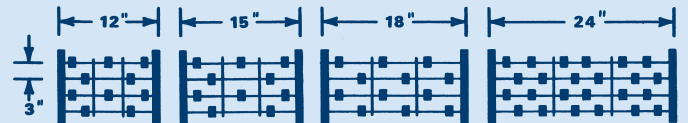
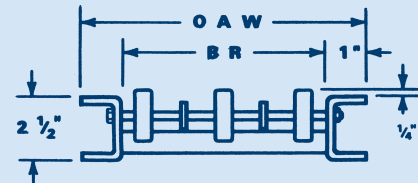

► SW SERIES GALVANIZED STEEL

Over-All Width In	Model No	Wheels Per Ft	WEIGHT	
			5 Ft Section Lbs	10 Ft Section Lbs
12	12-SW-06	6	24	49
	12-SW-10	10	29	57
	12-SW-12	12	31	59
	12-SW-16	16	33	67
15	15-SW-08	8	30	55
	15-SW-10	10	36	58
	15-SW-14	14	46	65
	15-SW-16	16	48	69
18	18-SW-12	12	32	66
	18-SW-14	14	35	70
	18-SW-16	16	37	73
	18-SW-18	18	38	77
20	20-SW-16	16	39	76
	20-SW-18	18	40	84
	20-SW-20	20	48	88
	20-SW-24	24	52	95
24	24-SW-18	18	42	83
	24-SW-20	20	44	86
	24-SW-24	24	47	92
	24-SW-28	28	50	99
30	30-SW-24	24	62	116
	30-SW-28	28	64	120
	30-SW-30	30	66	122

► AW SERIES ALUMINUM

Over-All Width In	Model No	Wheels Per Ft	WEIGHT	
			5 Ft Section Lbs	10 Ft Section Lbs
12	12-AW-06	6	17	32
	12-AW-10	10	19	36
	12-AW-12	12	20	38
	12-AW-16	16	23	42
15	15-AW-08	8	19	36
	15-AW-10	10	20	39
	15-AW-14	14	22	43
	15-AW-16	16	26	46
18	18-AW-12	12	23	45
	18-AW-14	14	24	47
	18-AW-16	16	25	48
	18-AW-18	18	26	51
20	20-AW-16	16	29	52
	20-AW-18	18	30	55
	20-AW-20	20	31	57
	20-AW-24	24	34	62
24	24-AW-18	18	29	57
	24-AW-20	20	30	59
	24-AW-24	24	33	64
	24-AW-28	28	34	68
30	30-AW-24	24	42	80
	30-AW-28	28	44	83
	30-AW-30	30	45	85

Skate Wheel Curves

45° and 90° skate wheel curves provide versatility to straight conveyors for moving products in various directions. Used in a variety of applications to complete a warehouse system. Tracking ability enables product to move around tight corners while providing excellent product alignment. Guard rails can be mounted to curve for additional product protection.

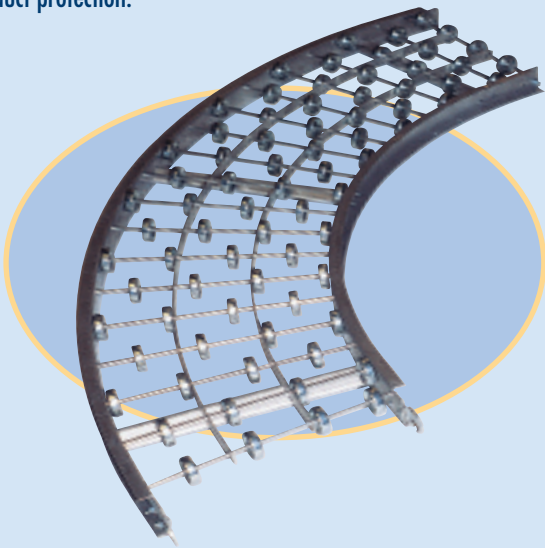
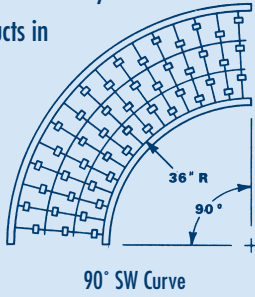

AW SERIES CURVE ALUMINUM

Over-All Width In	Wheels Per Ft	45° CURVE		90° CURVE	
		Model No	Weight Lbs	Model No	Weight Lbs
12	10	12-AW-10-45	11	12-AW-10-90	22
18	16	18-AW-16-45	15	18-AW-16-90	27
24	20	24-AW-20-45	18	24-AW-20-90	33
30	30	30-AW-30-45	22	30-AW-30-90	40

SW SERIES CURVE GALVANIZED STEEL

Over-All Width In	Wheels Per Ft	45° CURVE		90° CURVE	
		Model No	Weight Lbs	Model No	Weight Lbs
12	10	12-SW-10-45	30	12-SW-10-90	50
18	16	18-SW-16-45	40	18-SW-16-90	67
24	20	24-SW-20-45	48	24-SW-20-90	80
30	30	30-SW-30-45	55	30-SW-30-90	91

GENERAL SPECIFICATIONS:

See Skate Wheel Conveyors (Page 5) and Guard Rails (Page 18).

Skate Wheel Spurs

45° and 90° skate wheel spurs are used for converging or diverging two or more lines of material onto a main conveyor line. Specially designed for use in limited-access areas where exact entry is required by joining two lines of conveyor. Specify right or left hand unit. Various angles also available.

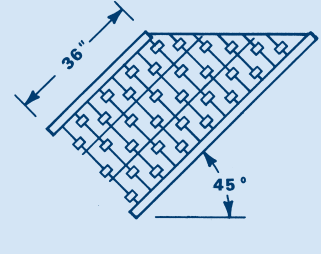
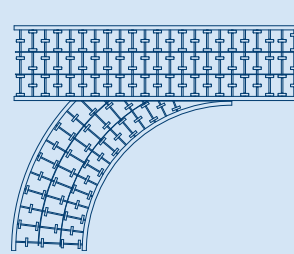
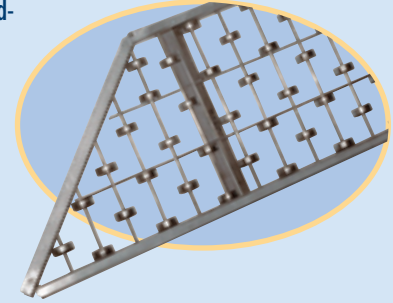

SW SERIES SPUR

Over-All Width In	Wheels Per Ft	45° SPUR		90° SPUR	
		Model No	Weight Lbs	Model No	Weight Lbs
12	10	12-SW-10-SC-45	31	12-SW-10-SC-90	68
18	16	18-SW-16-SC-45	38	18-SW-16-SC-90	78
24	20	24-SW-20-SC-45	45	24-SW-20-SC-90	106
30	30	30-SW-30-SC-45	53	30-SW-30-SC-90	134

Wheels Only

Choose from steel, heavy duty steel, aluminum, black nylon, and white nylon wheels. Special wheels available upon request. All have a 5/8" face width and bored for a 1/4" axle.



SKATE WHEELS ONLY

Diameter	Model No	Description	Capacity Lbs
2	SW	Steel Wheel	50
2	HDSW	Heavy Duty Steel Wheel	100
2	AW	Aluminum Wheel	40
2	BNW	Black Nylon Wheel	50
2	WNW	White Nylon Wheel	50
1½	SW-1.5	Steel Wheel	40

3/4" Micro Roller Conveyors*

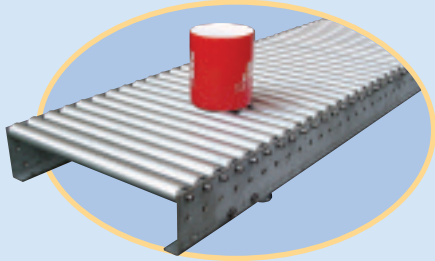
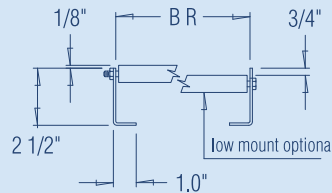

034-SR & 034-AR SERIES SPECIFICATIONS:

Rollers: 3/4", 20 Ga. Galv./Alum. ♦ Axles: 1/4" Round, Spring Loaded
 ♦ Frame: 2-1/2" x 1", 12 Ga. Galv. or 1/8" Alum. Formed Angle ♦ 5 Cross Braces ♦ Roller Cap.- Steel: 30 lbs., Alum.: 20 lbs. ♦ Option: Rollers set low.
 ♦ Poly Covers Available ♦ 10' Frame Capacity - Steel: 35 lbs/ft, Alum: 25 lbs/ft ♦ 5' Frame Capacity - Steel: 120 lbs/ft, Alum: 100 lbs/ft

7/8" Mini Roller Conveyors*

The 7/8" diameter plain steel or PVC mini rollers are similar to our 3/4" micro rollers series except for the roller itself. Our plain steel roller is 13 gauge with a capacity of 45 lbs. while our PVC roller has a capacity of 10 lbs. and is non-marking. Both are ideal for light packages and cartons while the 7/8" steel tube can take much more abuse.

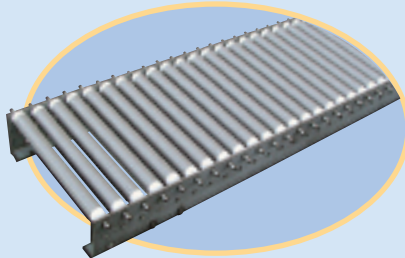

► 078-PVC .78" PVC ROLLER W/ STAINLESS STEEL BALL BEARINGS

Roller Centers In	Model No	Over-All Width In	Between Rail Width In	WEIGHT	
				5 Ft Section Lbs	10 Ft Section Lbs
1	078-PVC-0104	5	4	21	39
	078-PVC-0108	9	8	26	48
	078-PVC-0112	13	12	32	58
2	078-PVC-0204	5	4	16	29
	078-PVC-0208	9	8	20	38
	078-PVC-0212	13	12	24	45
3	078-PVC-0304	5	4	14	26
	078-PVC-0308	9	8	18	34
	078-PVC-0312	13	12	21	40

► 034-SR SERIES GALVANIZED STEEL

Roller Centers In	Model No	Over-All Width In	Between Rail Width In	WEIGHT	
				5 Ft Section Lbs	10 Ft Section Lbs
1	034-SR-0105	6	4 7/8	28	59
	034-SR-0111	12	10 3/8	38	79
	034-SR-0114	15	13 7/8	49	100
	034-SR-0118	19	17 7/8	58	114
2	034-SR-0205	6	4 7/8	19	38
	034-SR-0211	12	10 3/8	27	54
	034-SR-0214	15	13 3/8	31	62
	034-SR-0218	19	17 7/8	37	73

► 034-AR SERIES ALUMINUM

Roller Centers In	Model No	Over-All Width In	Between Rail Width In	WEIGHT	
				5 Ft Section Lbs	10 Ft Section Lbs
1	034-AR-0105	6	4 7/8	16	31
	034-AR-0111	12	10 3/8	24	49
	034-AR-0114	15	13 7/8	31	57
	034-AR-0118	19	17 7/8	35	73
2	034-AR-0205	6	4 7/8	14	23
	034-AR-0211	12	10 3/8	15	32
	034-AR-0214	15	13 7/8	19	38
	034-AR-0218	19	17 7/8	24	49

► 078-SR 7/8" 13 GAUGE STEEL ROLLER

Roller Centers In	Model No	Over-All Width In	Between Rail Width In	WEIGHT	
				5 Ft Section Lbs	10 Ft Section Lbs
1	078-SR-0105	6	4 7/8	39	81
	078-SR-0111	12	10 3/8	68	135
	078-SR-0114	15	13 3/8	94	171
	078-SR-0118	19	17 7/8	116	230
	078-SR-0122	23	21 7/8	130	260
2	078-SR-0205	6	4 7/8	29	54
	078-SR-0211	12	10 3/8	46	84
	078-SR-0214	15	13 3/8	55	100
	078-SR-0218	19	17 7/8	66	120
3	078-SR-0222	23	21 7/8	78	140
	078-SR-0305	6	4 7/8	23	49
	078-SR-0311	12	10 3/8	39	81
	078-SR-0314	15	13 7/8	46	93
	078-SR-0318	19	17 7/8	57	100
078-SR-0322	23	21 7/8	69	130	

*Micro & Mini Conveyors are also available in Curves. Contact factory.

1 3/8" Roller Conveyors

These 1-3/8" diameter gravity roller conveyors are extremely popular and are a standard in the industry. Ideal for the movement of light-medium weight packages. They are easily portable and can be used as a temporary or a permanent conveyor line. Poly covers available on 3" centers or more.



138-SR & 138-AR SERIES SPECIFICATIONS:

- Rollers: 1-3/8", 18 Ga. Galv./Alum. ♦ Axles: 1/4" Round, Spring Loaded
- ♦ Frame: 2-1/2" x 1" x 1", 12 Ga. Galv. or 1/8" Alum. Formed Channel
- ♦ 5 Cross Braces ♦ Hook and Bolt Couplers Standard ♦ Roller Cap. - Steel: 50 lbs, Alum.: 40 lbs ♦ 10' Frame Capacity - Steel: 50lbs/ft, Alum: 30lbs/ft
- ♦ 5' Frame Capacity - Steel: 200lbs/ft, Alum: 100lbs/ft

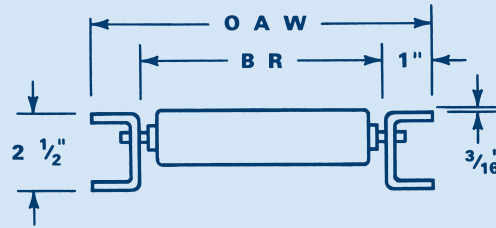

▶ 138-SR SERIES

Roller Centers In	Model No	Over-All Width In	Between Rail Width In	WEIGHT	
				5 Ft Section Lbs	10 Ft Section Lbs
1 1/2	138-SR-1512	12	10	49	98
	138-SR-1515	15	13	56	112
	138-SR-1518	18	16	67	130
	138-SR-1520	20	18	73	146
	138-SR-1524	24	22	87	168
3	138-SR-0312	12	10	33	65
	138-SR-0315	15	13	40	80
	138-SR-0318	18	16	43	82
	138-SR-0320	20	18	46	91
	138-SR-0324	24	22	53	101
4 1/2	138-SR-4512	12	10	27	53
	138-SR-4515	15	13	31	62
	138-SR-4518	18	16	36	68
	138-SR-4520	20	18	39	78
	138-SR-4524	24	22	43	83
6	138-SR-0612	12	10	25	49
	138-SR-0615	15	13	28	55
	138-SR-0618	18	16	33	62
	138-SR-0620	20	18	35	68
	138-SR-0624	24	22	37	71
12	138-SR-1212	12	10	25	46
	138-SR-1215	15	13	27	50
	138-SR-1218	18	16	29	53
	138-SR-1220	20	18	31	56
	138-SR-1224	24	22	33	60

▶ 138-AR SERIES

Roller Centers In	Model No	Over-All Width In	Between Rail Width In	WEIGHT	
				5 Ft Section Lbs	10 Ft Section Lbs
1 1/2	138-AR-1512	12	10	30	58
	138-AR-1515	15	13	34	68
	138-AR-1518	18	16	41	80
	138-AR-1520	20	18	43	89
	138-AR-1524	24	22	51	103
3	138-AR-0312	12	10	20	38
	138-AR-0315	15	13	22	43
	138-AR-0318	18	16	24	47
	138-AR-0320	20	18	26	50
	138-AR-0324	24	22	33	65
4 1/2	138-AR-4512	12	10	16	30
	138-AR-4515	15	13	18	36
	138-AR-4518	18	16	19	38
	138-AR-4520	20	18	20	39
	138-AR-4524	24	22	26	51
6	138-AR-0612	12	10	15	22
	138-AR-0615	15	13	18	32
	138-AR-0618	18	16	19	35
	138-AR-0620	20	18	20	37
	138-AR-0624	24	22	23	42
12	138-AR-1212	12	10	13	24
	138-AR-1215	15	13	15	27
	138-AR-1218	18	16	16	29
	138-AR-1220	20	18	17	31
	138-AR-1224	24	22	18	33

1 5/8" Stainless Roller Conveyors

Stainless steel construction renders this conveyor ideal for food equipment and other wash-down operations. U.S.D.A. approved.

158-SSR SERIES SPECIFICATIONS:

Rollers: 1-5/8", 16 Ga. Stainless Steel Tubing ♦ Delron Bearing with S.S. Balls
 ♦ Axles: 7/16" Hex S.S., Spring Loaded ♦ Frame: 2-1/2" x 1" x 1", 12 Ga. S.S. Formed Channel ♦ 5 Welded Cross Braces ♦ Roller Cap. - 100 lbs
 ♦ 10' Frame Capacity: 60lbs/ft ♦ 5' Frame Capacity: 235lbs/ft

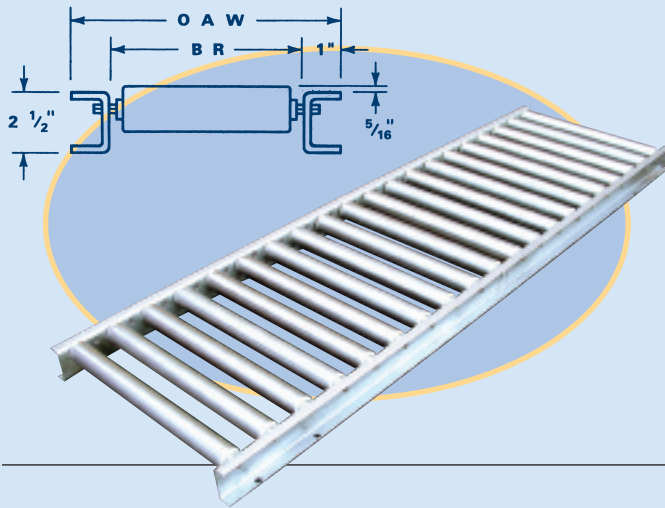

158-SSR SERIES

Roller Centers In	Model No	Over-All Width In	Between Rail Width In	WEIGHT	
				5 Ft Section Lbs	10 Ft Section Lbs
3	158-SSR-0312	12	10	55	101
	158-SSR-0318	18	16	76	139
	158-SSR-0324	24	22	97	177
	158-SSR-0330	30	28	118	206
4 1/2	158-SSR-4512	12	10	47	86
	158-SSR-4518	18	16	63	115
	158-SSR-4524	24	22	79	145
	158-SSR-4530	30	28	95	180
6	158-SSR-0612	12	10	39	70
	158-SSR-0618	18	16	51	93
	158-SSR-0624	24	22	56	103
	158-SSR-0630	30	28	63	115
12	158-SSR-1212	12	10	33	63
	158-SSR-1218	18	16	41	79
	158-SSR-1224	24	22	47	90
	158-SSR-1230	30	28	54	102

1.9" P.V.C. Roller Conveyors

The P.V.C. roller is the key ingredient for this non-marring conveyor. Specially ideal for glass handling, etc.

190-PVC SERIES SPECIFICATIONS:

Rollers: 1.9" P.V.C. Schedule 80 ♦ Wall Thickness: .200" ♦ Delron Bearing Stainless Steel Balls ♦ Axles: 7/16" Hex, Spring Loaded ♦ Frame: 3-1/2" x 1" x 1", 10 Ga. Painted Steel Formed Channel ♦ 5 Welded Cross Braces ♦ Butt Couplers Standard ♦ 5' Frame Capacity: 400lbs./ft.
 ♦ 10' Frame Capacity: 140lbs./ft. ♦ Roller Cap. - 100 lbs.

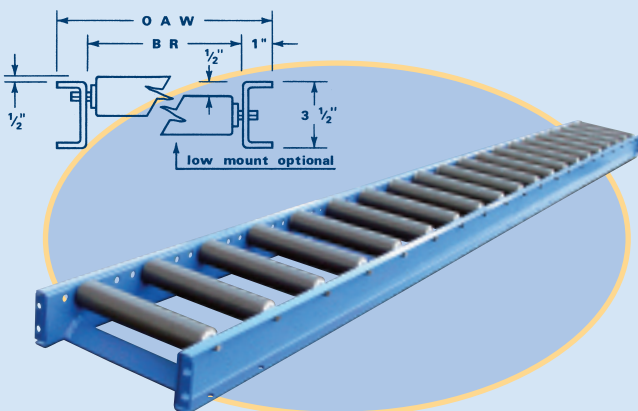

190-PVC SERIES

Roller Centers In	Model No	Over-All Width In	Between Rail Width In	WEIGHT	
				5 Ft Section Lbs	10 Ft Section Lbs
3	190-PVC-0312	12	10	65	125
	190-PVC-0318	18	16	85	165
	190-PVC-0324	24	22	95	185
	190-PVC-0330	30	28	110	215
4 1/2	190-PVC-4512	12	10	60	110
	190-PVC-4518	18	16	70	133
	190-PVC-4524	24	22	77	146
	190-PVC-4530	30	28	85	160
6	190-PVC-0612	12	10	55	103
	190-PVC-0618	18	16	60	117
	190-PVC-0624	24	22	68	132
	190-PVC-0630	30	28	76	147
12	190-PVC-1212	12	10	45	86
	190-PVC-1218	18	16	50	92
	190-PVC-1224	24	22	54	101
	190-PVC-1230	30	28	58	109

1.9" & 2" Light Duty Roller Conveyors

Economical, light weight. Ideal for handling cartons in temporary or permanent applications. Poly covers available.

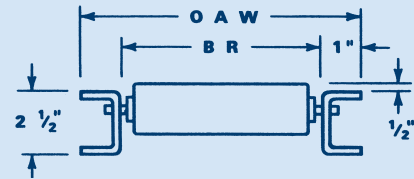

▶ 190-SRL SERIES

Roller Centers In	Model No	WEIGHT			
		Over-All Width In	Between Rail Width In	5 Ft Section Lbs	10 Ft Section Lbs
3	190-SRL-0312	12	10	48	95
	190-SRL-0315	15	13	55	112
	190-SRL-0318	18	16	64	127
	190-SRL-0320	20	18	81	136
	190-SRL-0324	24	22	84	156
	190-SRL-0326	26	24	85	171
	190-SRL-0330	30	28	96	193
4 1/2	190-SRL-4512	12	10	39	79
	190-SRL-4515	15	13	43	86
	190-SRL-4518	18	16	49	98
	190-SRL-4520	20	18	53	105
	190-SRL-4524	24	22	62	124
	190-SRL-4526	26	24	66	129
	190-SRL-4530	30	28	70	140
6	190-SRL-0612	12	10	33	66
	190-SRL-0615	15	13	37	75
	190-SRL-0618	18	16	39	82
	190-SRL-0620	20	18	45	89
	190-SRL-0624	24	22	52	102
	190-SRL-0626	26	24	53	106
	190-SRL-0630	30	28	59	117
12	190-SRL-1212	12	10	29	52
	190-SRL-1215	15	13	32	58
	190-SRL-1218	18	16	35	63
	190-SRL-1220	20	18	36	66
	190-SRL-1224	24	22	40	73
	190-SRL-1226	26	24	42	76
	190-SRL-1230	30	28	46	83

▶ 200-ARL SERIES

Roller Centers In	Model No	WEIGHT			
		Over-All Width In	Between Rail Width In	5 Ft Section Lbs	10 Ft Section Lbs
3	200-ARL-0312	12	10	27	53
	200-ARL-0315	15	13	32	63
	200-ARL-0318	18	16	34	72
	200-ARL-0320	20	18	38	75
	200-ARL-0324	24	22	42	83
4 1/2	200-ARL-4512	12	10	23	42
	200-ARL-4515	15	13	24	46
	200-ARL-4518	18	16	26	53
	200-ARL-4524	24	22	31	62
6	200-ARL-0612	12	10	18	36
	200-ARL-0615	15	13	20	40
	200-ARL-0618	18	16	23	45
	200-ARL-0620	20	18	25	48
12	200-ARL-1212	12	10	15	27
	200-ARL-1215	15	13	16	29
	200-ARL-1218	18	16	18	32
	200-ARL-1220	20	18	19	34
	200-ARL-1224	24	22	21	38

200-ARL & 190-SRL SERIES SPECIFICATIONS:

- Rollers: 1.9", 16 Ga. Galv./2" Alum. ♦ Axles: 1/4" Round, Spring Loaded
- ♦ Frame: 2-1/2" x 1" x 1", 12 Ga. Galv. or 1/8" Alum. Formed Channel
- ♦ 5 Cross Braces ♦ Hook and Bolt Couplers Standard ♦ Roller Capacity - Steel: 125lbs, Alum: 65lbs ♦ 10' Frame Capacity - Steel: 50lbs/ft, Alum: 30lbs/ft, ♦ 5' Frame Capacity - Steel: 200lbs/ft, Alum.: 100lbs/ft

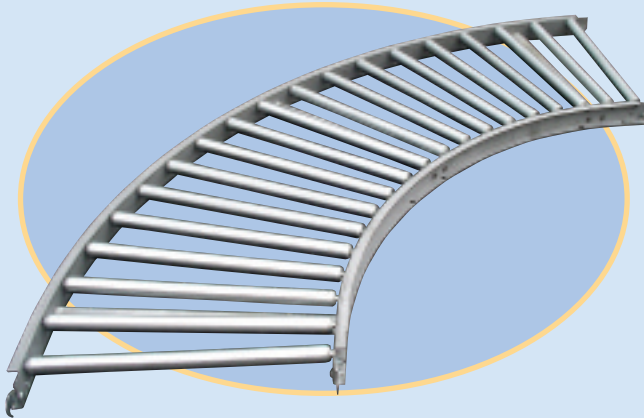

1-3/8" Curves available with 1-1/2" Centers.

Light Duty Curves

45° and 90° roller curves move products in various directions providing versatility to straight conveyors. Used in various applications to complete a warehouse system. For additional product protection, guard rails can be mounted to curve.

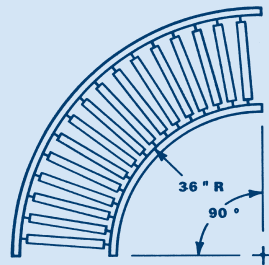

90° Roller Curve

GENERAL SPECIFICATIONS:

See 138 and 200 Series straight conveyors (Page 8 and 10)

Light Duty Spurs

These 45° and 90° roller spurs are used for converging and diverging several lines of material onto a main line. Specially made for use in limited access areas where exact entry is required by joining two or more lines of conveyor. Various angles available. Specify right or left hand unit.

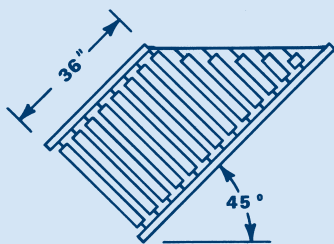

Right Hand 45° Roller Spur

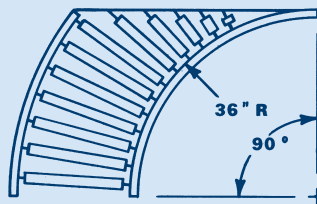

Right Hand 90° Roller Spur

▶ 138-SR SERIES—CURVE

Over-All Width In	Roller Centers In	45° CURVE		90° CURVE	
		Model No	Weight Lbs	Model No	Weight Lbs
12	3	138-SR-0312-45	17	138-SR-0312-90	34
18	3	138-SR-0318-45	22	138-SR-0318-90	43
24	3	138-SR-0324-45	28	138-SR-0324-90	61

▶ 138-AR SERIES—CURVE

Over-All Width In	Roller Centers In	45° CURVE		90° CURVE	
		Model No	Weight Lbs	Model No	Weight Lbs
12	3	138-AR-0312-45	10	138-AR-0312-90	20
18	3	138-AR-0318-45	13	138-AR-0318-90	26
24	3	138-AR-0324-45	16	138-AR-0324-90	32

▶ 190-SRL SERIES—CURVE

Over-All Width In	Roller Centers In	45° CURVE		90° CURVE	
		Model No	Weight Lbs	Model No	Weight Lbs
12	3	190-SRL-0312-45	23	190-SRL-0312-90	53
18	3	190-SRL-0318-45	32	190-SRL-0318-90	64
24	3	190-SRL-0324-45	40	190-SRL-0324-90	83

▶ 200-ARL SERIES—CURVE

Over-All Width In	Roller Centers In	45° CURVE		90° CURVE	
		Model No	Weight Lbs	Model No	Weight Lbs
12	3	200-ARL-0312-45	13	200-ARL-0312-90	27
18	3	200-ARL-0318-45	19	200-ARL-0318-90	35
24	3	200-ARL-0324-45	24	200-ARL-0324-90	42

▶ 138-SR SERIES—SPUR

Over-All Width In	Roller Centers In	45° SPUR		90° SPUR	
		Model No	Weight Lbs	Model No	Weight Lbs
12	3	138-SR-0312-SC-45	30	138-SR-0312-SC-90	37
18	3	138-SR-0318-SC-45	43	138-SR-0318-SC-90	57
24	3	138-SR-0324-SC-45	54	138-SR-0324-SC-90	74

▶ 190-SRL SERIES—SPUR

Over-All Width In	Roller Centers In	45° SPUR		90° SPUR	
		Model No	Weight Lbs	Model No	Weight Lbs
12	3	190-SRL-0312-SC-45	45	190-SRL-0312-SC-90	60
18	3	190-SRL-0318-SC-45	60	190-SRL-0318-SC-90	81
24	3	190-SRL-0324-SC-45	72	190-SRL-0324-SC-90	96

1.9" Medium / Heavy Duty Roller Conveyors

For permanent industrial usage. All-welded construction creates a durable conveyor. Check these superior features in a 1.9" medium duty roller conveyor. 2-1/4" roller centers available. Poly covered rollers available.

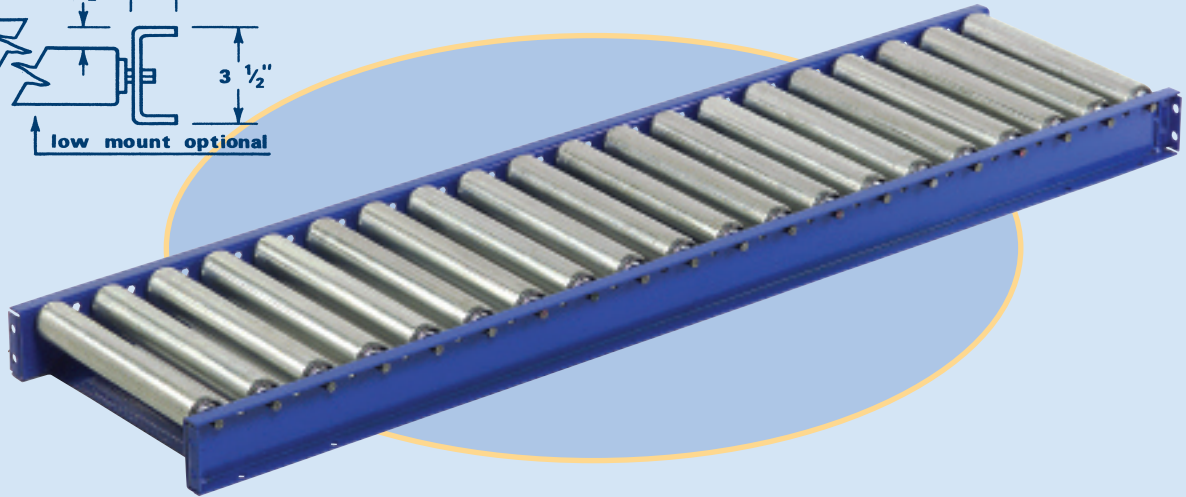
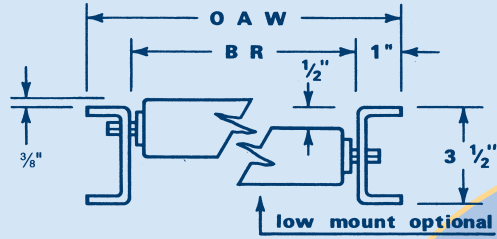

190-SRM SERIES SPECIFICATIONS:

Rollers: 1.9" 16 gauge galvanized steel ♦ Axles: 7/16" Hex, Spring Loaded
 ♦ Frame: 3-1/2" x 1" x 1", 10 Ga. Powder Coated Blue Steel Formed Channel ♦ Welded Cross Braces ♦ Butt Couplers Standard ♦ 10' Frame Capacity: 140 lbs/ft. ♦ 5' Frame Capacity: 500 lbs/ft. ♦ Roller Cap. - 250 lbs.

▶ 190-SRM SERIES

Roller Centers In	Model No	Over-All Width In	Between Rail Width In	WEIGHT	
				5 Ft Section Lbs	10 Ft Section Lbs
3	190-SRM-0312	12	10	65	130
	190-SRM-0315	15	13	78	156
	190-SRM-0318	18	16	87	174
	190-SRM-0320	20	18	106	192
	190-SRM-0324	24	22	103	205
	190-SRM-0326	26	24	129	234
	190-SRM-0330	30	28	131	262
	190-SRM-0332	32	30	139	277
	190-SRM-0336	36	34	153	305
	190-SRM-0342	42	40	174	347
	190-SRM-0348	48	46	195	389
4 1/2	190-SRM-4512	12	10	52	104
	190-SRM-4515	15	13	59	118
	190-SRM-4518	18	16	69	137
	190-SRM-4520	20	18	82	148
	190-SRM-4524	24	22	87	173
	190-SRM-4526	26	24	99	180
	190-SRM-4530	30	28	110	200
	190-SRM-4532	32	30	115	210
	190-SRM-4536	36	34	126	230
	190-SRM-4542	42	40	138	260
	190-SRM-4548	48	46	150	290

▶ 190-SRM SERIES (CONTINUED)

Roller Centers In	Model No	Over-All Width In	Between Rail Width In	WEIGHT	
				5 Ft Section Lbs	10 Ft Section Lbs
6	190-SRM-0612	12	10	41	81
	190-SRM-0615	15	13	54	107
	190-SRM-0618	18	16	65	119
	190-SRM-0620	20	18	70	127
	190-SRM-0624	24	22	78	142
	190-SRM-0626	26	24	82	150
	190-SRM-0630	30	28	91	166
	190-SRM-0632	32	30	96	174
	190-SRM-0636	36	34	104	189
	190-SRM-0642	42	40	116	213
	190-SRM-0648	48	46	128	237
12	190-SRM-1212	12	10	42	76
	190-SRM-1215	15	13	46	83
	190-SRM-1218	18	16	49	90
	190-SRM-1220	20	18	52	94
	190-SRM-1224	24	22	57	104
	190-SRM-1226	26	24	59	108
	190-SRM-1230	30	28	65	118
	190-SRM-1232	32	30	67	122
	190-SRM-1236	36	34	73	132
	190-SRM-1242	42	40	82	147
	190-SRM-1248	48	46	91	162

2" Heavy Duty Roller Conveyors

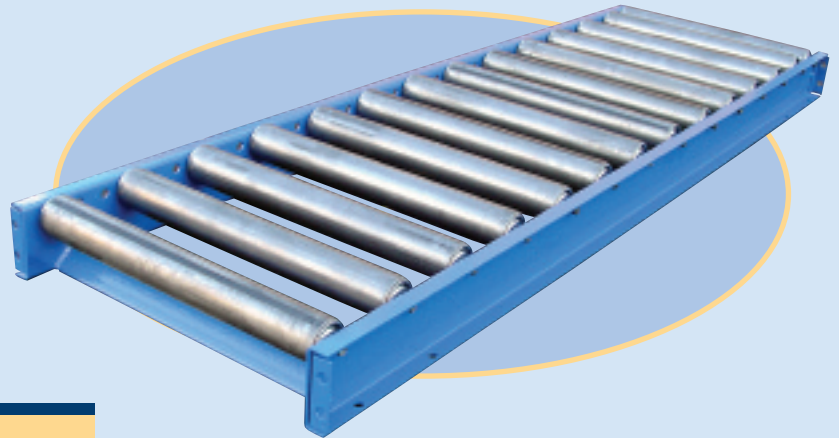
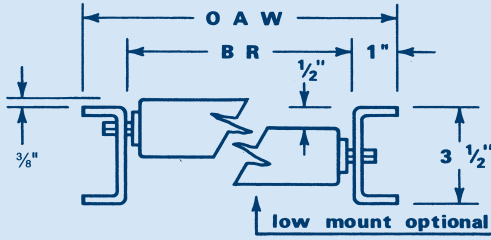

200-SRH SERIES SPECIFICATIONS:

Rollers: 2" 12 gauge plain steel ♦ Axles: 7/16" Hex, Spring Loaded ♦ Frame: 3-1/2" x 1" x 1", 10 Ga. Powder Coated Blue Steel Formed Channel ♦ Welded Cross Braces ♦ Butt Couplers Standard ♦ 10' Frame Capacity: 140 lbs/ft. ♦ 5' Frame Capacity: 500lbs/ft. ♦ Roller Cap. - 300 lbs.

▶ 200-SRH SERIES

Roller Centers In	Model No	Over-All Width In	Between Rail Width In	WEIGHT	
				5 Ft Section Lbs	10 Ft Section Lbs
3	200-SRH-0312	12	10	87	162
	200-SRH-0315	15	13	91	175
	200-SRH-0318	18	16	122	222
	200-SRH-0320	20	18	133	242
	200-SRH-0324	24	22	155	282
	200-SRH-0326	26	24	166	302
	200-SRH-0330	30	28	188	342
	200-SRH-0332	32	30	199	361
	200-SRH-0336	36	34	221	401
	200-SRH-0342	42	40	245	463
	200-SRH-0348	48	46	269	525
	200-SRH-0352	52	50	284	568
4 1/2	200-SRH-4512	12	10	70	128
	200-SRH-4515	15	13	82	149
	200-SRH-4518	18	16	93	169
	200-SRH-4520	20	18	101	183
	200-SRH-4524	24	22	116	211
	200-SRH-4526	26	24	124	225
	200-SRH-4530	30	28	139	253
	200-SRH-4532	32	30	147	267
	200-SRH-4536	36	34	162	295
	200-SRH-4542	42	40	186	337
	200-SRH-4548	48	46	210	421
	200-SRH-4552	52	50	226	449

▶ 200-SRH SERIES (CONTINUED)

Roller Centers In	Model No	Over-All Width In	Between Rail Width In	WEIGHT	
				5 Ft Section Lbs	10 Ft Section Lbs
6	200-SRH-0612	12	10	60	109
	200-SRH-0615	15	13	69	125
	200-SRH-0618	18	16	78	141
	200-SRH-0620	20	18	84	152
	200-SRH-0624	24	22	96	173
	200-SRH-0626	26	24	101	184
	200-SRH-0630	30	28	113	205
	200-SRH-0632	32	30	119	216
	200-SRH-0636	36	34	131	238
	200-SRH-0642	42	40	149	274
	200-SRH-0648	48	46	167	310
	200-SRH-0652	52	50	179	334
12	200-SRH-1212	12	10	45	82
	200-SRH-1215	15	13	51	92
	200-SRH-1218	18	16	56	101
	200-SRH-1220	20	18	59	107
	200-SRH-1224	24	22	65	119
	200-SRH-1226	26	24	69	125
	200-SRH-1230	30	28	75	137
	200-SRH-1232	32	30	79	143
	200-SRH-1236	36	34	89	156
	200-SRH-1242	42	40	100	177
	200-SRH-1248	48	46	111	198
	200-SRH-1252	52	50	119	212

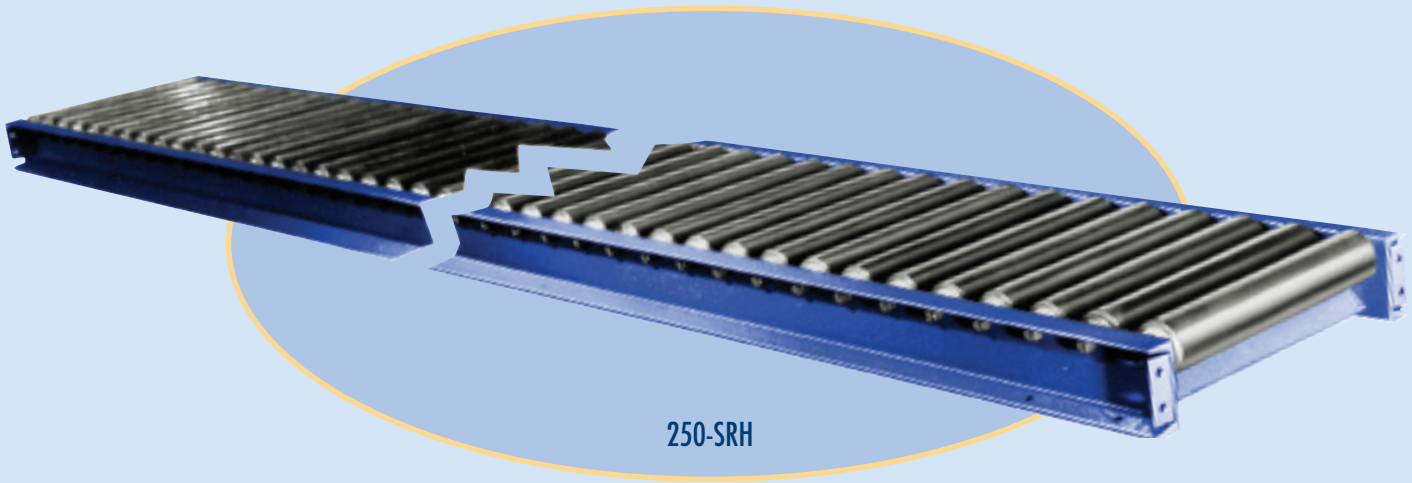

2½" Medium & Heavy Duty Roller Conveyors

These conveyors are for heavier duty industrial applications.

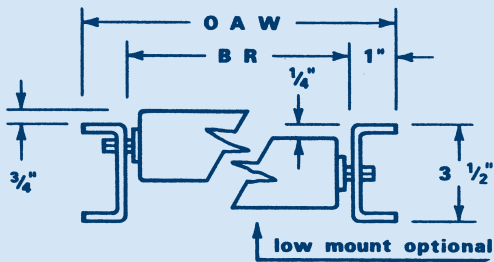

2-1/2" Medium Duty Roller Conveyor

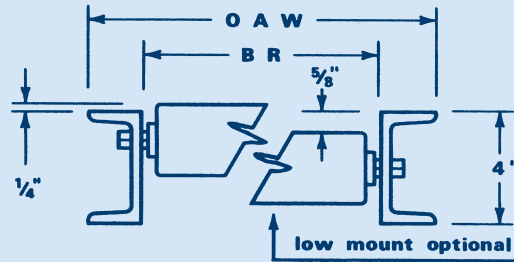

2-1/2" Heavy Duty Roller Conveyor

250-SRM SERIES SPECIFICATIONS:

Rollers: 2-1/2", 14 Ga. ♦ Axles: 7/16" Hex, Spring Loaded ♦ Frame: 3-1/2" x 1" x 1", 10 Ga. Powder Coated Blue Steel Formed Channel ♦ 5 Welded Cross Braces ♦ Butt Couplers Standard ♦ Roller Cap. - 280lbs ♦ 10' Frame Capacity: 140lbs/ft ♦ 5' Frame Capacity: 500lbs/ft

250-SRH SERIES SPECIFICATIONS:

Rollers: 2-1/2", 11 Ga. ♦ Axles: 11/16" Hex, Spring Loaded Frame: 4" x 5.4" Structural Channel Powder Coated Blue ♦ 5 Welded Cross Braces ♦ Butt Couplers Standard ♦ Roller Cap. - 750lbs ♦ 10' Frame Capacity: 350lbs/ft ♦ 5' Frame Capacity: 1,100lbs/ft ♦ Structural Channel Powder Coated Blue

► 250-SRM SERIES

Roller Centers In	Model No	Over-All Width In	Between Rail Width In	WEIGHT	
				5 Ft Section Lbs	10 Ft Section Lbs
3	250-SRM-0312	12	10	91	165
	250-SRM-0315	15	13	107	194
	250-SRM-0318	18	16	123	224
	250-SRM-0324	24	22	156	283
	250-SRM-0330	30	28	188	341
	250-SRM-0336	36	34	221	401
	250-SRM-0342	42	40	251	457
	250-SRM-0348	48	46	281	513
4½	250-SRM-4512	12	10	71	129
	250-SRM-4515	15	13	82	149
	250-SRM-4518	18	16	93	169
	250-SRM-4524	24	22	116	211
	250-SRM-4530	30	28	139	252
	250-SRM-4536	36	34	156	293
	250-SRM-4542	42	40	184	334
	250-SRM-4548	48	46	212	375
6	250-SRM-0612	12	10	62	112
	250-SRM-0615	15	13	69	126
	250-SRM-0618	18	16	78	141
	250-SRM-0624	24	22	95	173
	250-SRM-0630	30	28	113	205
	250-SRM-0636	36	34	130	236
	250-SRM-0642	42	40	147	268
	250-SRM-0648	48	46	164	300
12	250-SRM-1212	12	10	46	83
	250-SRM-1215	15	13	51	92
	250-SRM-1218	18	16	56	101
	250-SRM-1224	24	22	65	119
	250-SRM-1230	30	28	75	137
	250-SRM-1236	36	34	85	155
	250-SRM-1242	42	40	95	173
	250-SRM-1248	48	46	105	191

► 250-SRH SERIES

Roller Centers In	Model No	Over-All Width In	Between Rail Width In	WEIGHT	
				5 Ft Section Lbs	10 Ft Section Lbs
3	250-SRH-0312	12	9	147	294
	250-SRH-0315	15	12	172	344
	250-SRH-0318	18	15	196	391
	250-SRH-0324	24	21	243	486
	250-SRH-0330	30	27	320	581
	250-SRH-0336	36	33	372	676
	250-SRH-0342	42	39	424	771
	250-SRH-0352	52	49	511	930
	4	250-SRH-0412	12	9	121
250-SRH-0415		15	12	158	288
250-SRH-0418		18	15	163	325
250-SRH-0424		24	21	199	397
250-SRH-0430		30	27	233	470
250-SRH-0436		36	33	299	543
250-SRH-0442		42	39	339	617
250-SRH-0452		52	49	406	741
6		250-SRH-0612	12	9	104
	250-SRH-0615	15	12	128	233
	250-SRH-0618	18	15	130	258
	250-SRH-0624	24	21	155	309
	250-SRH-0630	30	27	197	359
	250-SRH-0636	36	33	225	410
	250-SRH-0642	42	39	230	460
	250-SRH-0652	52	49	300	544
	12	250-SRH-1212	12	9	90
250-SRH-1215		15	12	97	177
250-SRH-1218		18	15	106	192
250-SRH-1224		24	21	121	220
250-SRH-1230		30	27	136	248
250-SRH-1236		36	33	152	277
250-SRH-1242		42	39	168	305
250-SRH-1252		52	49	195	352

Extra Heavy Duty Roller Conveyors

2-5/8" diameter extra heavy 7 gauge roller utilizes all of the features of the 250-SRH Series conveyor.

3-1/2" diameter combined with 6" super heavy duty frame is indestructible.



258-SRH SERIES SPECIFICATIONS:

Rollers: 2-5/8", 7 Ga. ♦ Axles: 11/16" Hex, Spring Loaded ♦ Frame: 4" x 5.4 lbs/ft Structural Channel ♦ 5 Welded Cross Braces ♦ Butt Couplers Standard ♦ Roller Cap. - 800 lbs. ♦ Rollers can be set low in frame ♦ 10' Frame Capacity: 350lbs/ft ♦ 5' Frame Capacity: 1100lbs/ft ♦ Powder Coated Blue

▶ 258-SRH SERIES

Roller Centers In	Model No	Over-All Width In	Between Rail Width In	WEIGHT	
				5 Ft Section Lbs	10 Ft Section Lbs
3	258-SRH-0312	12	9	187	340
	258-SRH-0315	15	12	223	404
	258-SRH-0318	18	15	257	468
	258-SRH-0324	24	21	328	596
	258-SRH-0330	30	27	398	724
	258-SRH-0336	36	33	469	852
	258-SRH-0342	42	39	539	980
4	258-SRH-0412	12	9	156	284
	258-SRH-0415	15	12	184	335
	258-SRH-0418	18	15	210	382
	258-SRH-0424	24	21	264	480
	258-SRH-0430	30	27	317	577
	258-SRH-0436	36	33	371	675
	258-SRH-0442	42	39	425	772
6	258-SRH-0612	12	9	127	230
	258-SRH-0615	15	12	145	263
	258-SRH-0618	18	15	163	297
	258-SRH-0624	24	21	200	364
	258-SRH-0630	30	27	237	431
	258-SRH-0636	36	33	274	498
	258-SRH-0642	42	39	310	564
12	258-SRH-1212	12	9	71	174
	258-SRH-1215	15	12	82	192
	258-SRH-1218	18	15	93	211
	258-SRH-1224	24	21	116	247
	258-SRH-1230	30	27	139	284
	258-SRH-1236	36	33	156	320
	258-SRH-1242	42	39	184	357

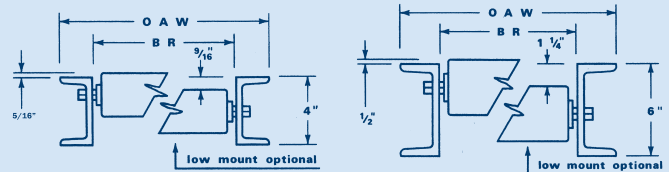

2-5/8" Extra Heavy Duty Roller Conveyor

3-1/2" Extra Heavy Duty Roller Conveyor

350-SRH SERIES SPECIFICATIONS:

Rollers: 3-1/2" x .216 Wall Thickness ♦ Axles: 1-1/16" Hex, Drilled for Cotter Pins ♦ Frame: 6" x 8.2 lbs/ft Structural Channel ♦ Powder Coated Blue ♦ 5 Welded Cross Braces ♦ Roller Cap. - 1100 lbs. ♦ Rollers can be set low as an option ♦ 10' Frame Capacity: 860lbs/ft ♦ 5' Frame Capacity: 1800 lbs/ft

▶ 350-SRH SERIES

Roller Centers In	Model No	Over-All Width In	Between Rail Width In	WEIGHT	
				5 Ft Section Lbs	10 Ft Section Lbs
4	350-SRH-0412	12	8	263	515
	350-SRH-0418	18	14	346	680
	350-SRH-0424	24	20	434	855
	350-SRH-0430	30	26	522	1025
	350-SRH-0436	36	32	609	1194
	350-SRH-0442	42	38	710	1362
8	350-SRH-0812	12	8	178	346
	350-SRH-0818	18	14	226	435
	350-SRH-0824	24	20	273	522
	350-SRH-0830	30	26	320	610
	350-SRH-0836	36	32	371	701
	350-SRH-0842	42	38	443	804
12	350-SRH-1212	12	8	152	290
	350-SRH-1218	18	14	185	350
	350-SRH-1224	24	20	220	415
	350-SRH-1230	30	26	248	473
	350-SRH-1236	36	32	275	532
	350-SRH-1242	42	38	318	596

Medium & Heavy Duty Curves & Spurs

CURVES: These heavier duty units either 45° or 90° can be used to move packages and boxes around corners or obstacles to complete a conveyor line. Guard rails can be added for extra protection.

SPURS: Durable 45° and 90° roller spurs are used in limited access areas where exact entry is required to join several lines of conveyor. Specify right or left hand unit. Special angle spurs are also available.

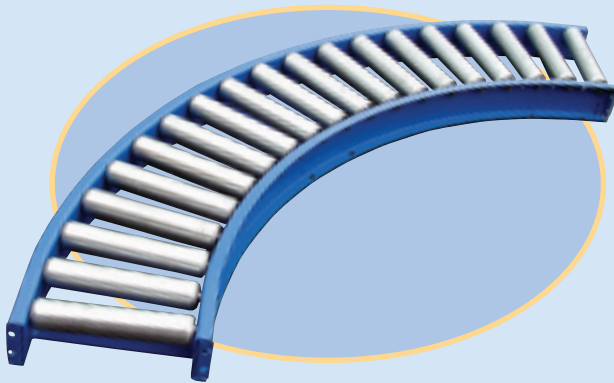

GENERAL SPECIFICATIONS:

See corresponding 190, 200, and 250 Series straight section conveyors (Pages 12, 13, 14).

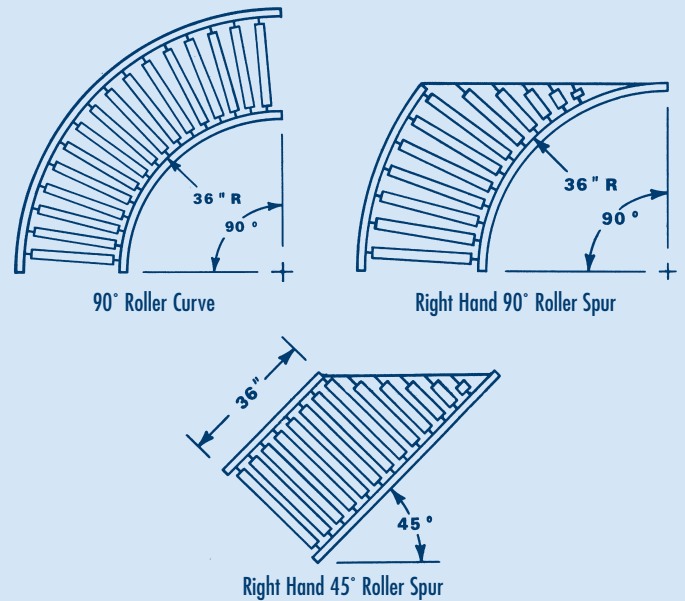

▶ 190-SRM SERIES—CURVE

Over-All Width In	Roller Centers In	45° CURVE		90° CURVE	
		Model No	Weight Lbs	Model No	Weight Lbs
12	3	190-SRM-0312-45	45	190-SRM-0312-90	75
18	3	190-SRM-0318-45	57	190-SRM-0318-90	95
24	3	190-SRM-0324-45	66	190-SRM-0324-90	110
30	3	190-SRM-0330-45	77	190-SRM-0330-90	128
36	3	190-SRM-0336-45	88	190-SRM-0336-90	151

▶ 190-SRM SERIES—SPUR

Over-All Width In	Roller Centers In	45° SPUR		90° SPUR	
		Model No	Weight Lbs	Model No	Weight Lbs
12	3	190-SRM-0312-SC-45	60	190-SRM-0312-SC-90	90
18	3	190-SRM-0318-SC-45	76	190-SRM-0318-SC-90	114
24	3	190-SRM-0324-SC-45	88	190-SRM-0324-SC-90	132

▶ 250-SRM SERIES—CURVE

Over-All Width In	Roller Centers In	45° CURVE		90° CURVE	
		Model No	Weight Lbs	Model No	Weight Lbs
12	3	250-SRM-0312-45	51	250-SRM-0312-90	85
18	3	250-SRM-0318-45	72	250-SRM-0318-90	121
24	3	250-SRM-0324-45	90	250-SRM-0324-90	152
30	3	250-SRM-0330-45	101	250-SRM-0330-90	191
36	3	250-SRM-0336-45	117	250-SRM-0336-90	220

▶ 200-SRH SERIES—CURVE

Over-All Width In	Roller Centers In	45° CURVE		90° CURVE	
		Model No	Weight Lbs	Model No	Weight Lbs
12	3	200-SRH-0312-45	51	200-SRH-0312-90	85
18	3	200-SRH-0318-45	72	200-SRH-0318-90	121
24	3	200-SRH-0324-45	90	200-SRH-0324-90	152
30	3	200-SRH-0330-45	109	200-SRH-0330-90	183
36	3	200-SRH-0336-45	130	200-SRH-0336-90	214

▶ 200-SRH SERIES—SPUR

Over-All Width In	Roller Centers In	45° SPUR		90° SPUR	
		Model No	Weight Lbs	Model No	Weight Lbs
12	3	200-SRH-0312-SC-45	68	200-SRH-0312-SC-90	102
18	3	200-SRH-0318-SC-45	96	200-SRH-0318-SC-90	144
24	3	200-SRH-0324-SC-45	121	200-SRH-0324-SC-90	181

▶ 250-SRH SERIES—CURVE

Over-All Width In	Roller Centers In	45° CURVE		90° CURVE	
		Model No	Weight Lbs	Model No	Weight Lbs
12	3	250-SRH-0312-45	88	250-SRH-0312-90	162
18	3	250-SRH-0318-45	112	250-SRH-0318-90	210
24	3	250-SRH-0324-45	135	250-SRH-0324-90	260
30	3	250-SRH-0330-45	157	250-SRH-0330-90	311
36	3	250-SRH-0336-45	179	250-SRH-0336-90	362

Conveyor Accessories

GUARD RAILS

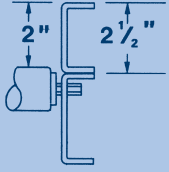

Channel Type Guardrail:
Bolt-On 2-1/2" x 1" x 1"
12 Ga. Steel or 1/8" Alum.

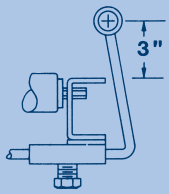

Adjustable Guardrail:
Lateral Adjustment Only

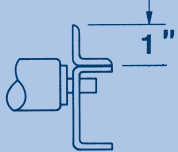

Angle Type Guardrail:
1" x 1" x 1/8" Steel

STOPS

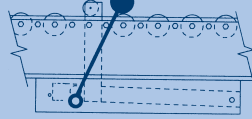

Hand Operated Roller Stop:
Hand operated push-up roller type

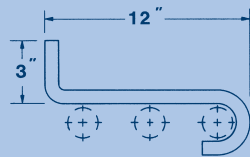

Package Stop:
12 Ga. removable hook-on type provides positive stops

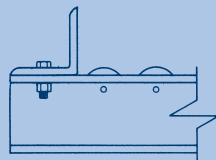

Angle End Stop:
1-1/2" x 1-1/2" x 10 Ga. Steel angle usually bolted to end of conveyor frame.

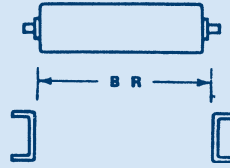

Due to differences in bearing hub projections, all rollers must be ordered with a between rail dimension or out to out length on bearings. Precision bearings available on 1.9" and 2.5" rollers.

ROLLERS ONLY

Model No	O.D. Tubing In	Finish	Gauge Material	Axle Size In
034-AR	3/4	Alum	20	1/4 rd
034-SR	3/4	Galv	20	1/4 rd
078-SR	7/8	Plain	13	1/4 rd
138-AR	1 3/8	Alum	18	1/4 rd
138-SR	1 3/8	Galv	18	1/4 rd
138-SRM	1 3/8	Galv	18	5/16 hex
158-SSR	1 5/8	Stainless Steel	16	3/16 hex
190-PVC	1.9	PVC	.145	3/16 hex
190-SRL	1.9	Galv	16	1/4 rd
190-SRM	1.9	Galv	16	3/16 hex
190-SRH	1.9	Plain	12	3/16 hex
200-SSR	2	Stainless Steel	16	3/16 hex
200-ARL	2	Alum	16	1/4 rd
200-SRL	2	Galv	16	1/4 rd
200-SRM	2	Galv	16	3/16 hex
200-SRH	2	Plain	12	3/16 hex
250-SRM	2 1/2	Plain	14	3/16 hex
250-SRH	2 1/2	Plain	11	1 1/16 hex
258-SRH	2 5/8	Plain	7	1 1/16 hex
350-SRH	3 1/2	Plain	.216	1 1/16 hex
350-SRM	3 1/2	Plain	10	1 1/16 hex

GUARDRAILS

Over-All Width In	MODEL NUMBER-CHANNEL			MODEL NUMBER-ADJUSTABLE			MODEL NUMBER-ANGLE		
	10 Ft	45°	90°	10 Ft	45°	90°	10 Ft	45°	90°
12	12-CHR-10	12-CHR-45	12-CHR-90	12-AJR-10	12-AJR-45	12-AJR-90	12-AGR-10	12-AGR-45	12-AGR-90
18	18-CHR-10	18-CHR-45	18-CHR-90	18-AJR-10	18-AJR-45	18-AJR-90	18-AGR-10	18-AGR-45	18-AGR-90
24	24-CHR-10	24-CHR-45	24-CHR-90	24-AJR-10	24-AJR-45	24-AJR-90	24-AGR-10	24-AGR-45	24-AGR-90

STOPS

Over-All Width In	ROLLER STOP			PACKAGE STOP			ANGLE END STOP		
	Model No	Between Rail Width In	Weight Lbs	Model No	Between Rail Width In	Weight Lbs	Model No	Between Rail Width In	Weight Lbs
12	HRS-12	10	4	PKS-12	10	2	AGS-12	10	2
15	HRS-15	13	5	PKS-15	13	3	AGS-15	13	3
18	HRS-18	16	6	PKS-18	16	4	AGS-18	16	4
24	HRS-24	22	7	PKS-24	22	5	AGS-24	22	5

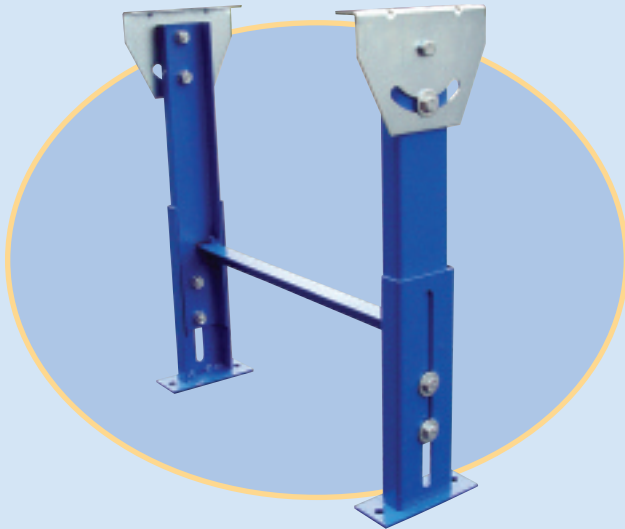

► **LIGHT DUTY STANDS**

Formed 12 gauge channel legs with adjustable plates for incline or decline. Prepunched feet for permanent installation. Capacity: 1000 lbs. Powder coated blue. Also available in stainless steel.

Over-All Conveyor Width In	ADJUSTABLE HEIGHT TOP OF STAND				
	Model No 14" to 17"	Model No 17" to 23"	Model No 24" to 30"	Model No 31" to 37"	Model No 38" to 44"
12	PSL-12-1417	PSL-12-1723	PSL-12-2430	PSL-12-3137	PSL-12-3844
15	PSL-15-1417	PSL-15-1723	PSL-15-2430	PSL-15-3137	PSL-15-3844
18	PSL-18-1417	PSL-18-1723	PSL-18-2430	PSL-18-3137	PSL-18-3844
20	PSL-20-1417	PSL-20-1723	PSL-20-2430	PSL-20-3137	PSL-20-3844
24	PSL-24-1417	PSL-24-1723	PSL-24-2430	PSL-24-3137	PSL-24-3844
26	PSL-26-1417	PSL-26-1723	PSL-26-2430	PSL-26-3137	PSL-26-3844
30	PSL-30-1417	PSL-30-1723	PSL-30-2430	PSL-30-3137	PSL-30-3844
36	PSL-36-1417	PSL-36-1723	PSL-36-2430	PSL-36-3137	PSL-36-3844



► **HEAVY DUTY STANDS**

2" square tubing legs with adjustable plates for incline or decline. Prepunched feet for permanent installation. Capacity: 2000 lbs. Powder coated blue.

Over-All Conveyor Width In	ADJUSTABLE HEIGHT TOP OF STAND			
	Model No 17" to 23"	Model No 24" to 30"	Model No 31" to 37"	Model No 38" to 44"
12	PSH-12-1723	PSH-12-2430	PSH-12-3137	PSH-12-3844
18	PSH-18-1723	PSH-18-2430	PSH-18-3137	PSH-18-3844
24	PSH-24-1723	PSH-24-2430	PSH-24-3137	PSH-24-3844
30	PSH-30-1723	PSH-30-2430	PSH-30-3137	PSH-30-3844
36	PSH-36-1723	PSH-36-2430	PSH-36-3137	PSH-36-3844
42	PSH-42-1723	PSH-42-2430	PSH-42-3137	PSH-42-3844



► **SUPER DUTY STANDS**

4" structural steel upright. 1" adjustable increments. Capacity: 4000 lbs. Powder coated blue.

Over-All Conveyor Width In	ADJUSTABLE HEIGHT TOP OF STAND			
	Model No 17" to 23"	Model No 24" to 30"	Model No 31" to 37"	Model No 38" to 44"
12	PSXH-12-1723	PSXH-12-2430	PSXH-12-3137	PSXH-12-3844
18	PSXH-18-1723	PSXH-18-2430	PSXH-18-3137	PSXH-18-3844
24	PSXH-24-1723	PSXH-24-2430	PSXH-24-3137	PSXH-24-3844
30	PSXH-30-1723	PSXH-30-2430	PSXH-30-3137	PSXH-30-3844
36	PSXH-36-1723	PSXH-36-2430	PSXH-36-3137	PSXH-36-3844
42	PSXH-42-1723	PSXH-42-2430	PSXH-42-3137	PSXH-42-3844



► **TRIPOD STANDS**

Portable, durable, 3-legged support. Ideal for temporary installations. Powder coated blue.

Over-All Conveyor Width In	ADJUSTABLE HEIGHT				
	Model No 12" to 18"	Model No 18" to 30"	Model No 24" to 40"	Model No 30" to 50"	Model No 40" to 70"
12	TP-12-1218	TP-12-1830	TP-12-2440	TP-12-3050	TP-12-4070
15	TP-15-1218	TP-15-1830	TP-15-2440	TP-15-3050	TP-15-4070
18	TP-18-1218	TP-18-1830	TP-18-2440	TP-18-3050	TP-18-4070
20	TP-20-1218	TP-20-1830	TP-20-2440	TP-20-3050	TP-20-4070
24	TP-24-1218	TP-24-1830	TP-24-2440	TP-24-3050	TP-24-4070



► **MOBILE STANDS**

These supports are easily transportable with four double ball bearing swivel casters. Standard with wheel brakes. Can be moved anywhere in your plant. Heights can also be adjusted. Can be used with skate wheel or light duty conveyors. Powder coated blue.

Over-All Conveyor Width In	ADJUSTABLE HEIGHT		
	Model No 18" to 30"	Model No 24" to 40"	Model No 30" to 50"
12	MS-12-1830-10	MS-12-2440-10	MS-12-3050-10
	MS-12-1830-90	MS-12-2440-90	MS-12-3050-90
18	MS-18-1830-10	MS-18-2440-10	MS-18-3050-10
	MS-18-1830-90	MS-18-2440-90	MS-18-3050-90
24	MS-24-1830-10	MS-24-2440-10	MS-24-3050-10
	MS-24-1830-90	MS-24-2440-90	MS-24-3050-90



► **HEAVY DUTY V STAND**

V-stand with 6" swivel casters with brakes holds up to 16" pipe. Capacity: 2000 lbs. Powder coated blue.

Over-All Width In	Adjustable Height In	Capacity Lbs	Model No
12"	36 to 46	2000	HDVS
Shipping Weight: 83 lbs			

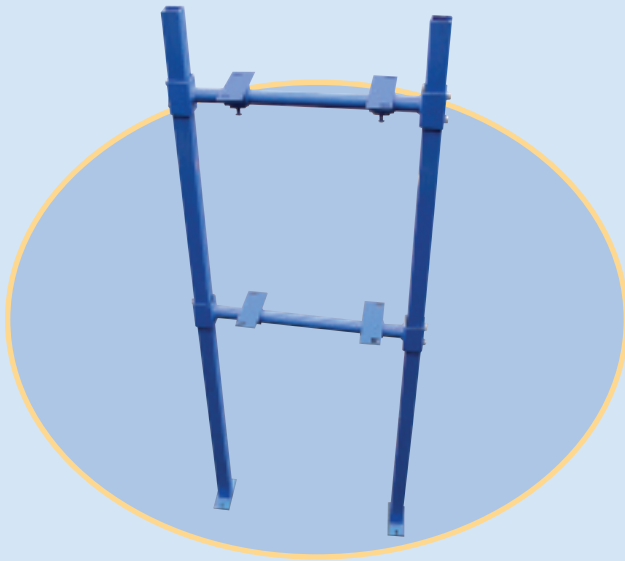

► **TIER STANDS**

Tier stand provides support for multi-level installation of conveyor lines. Two tiers standard with extra tiers available for special applications. Capacity: 2500 lbs. Consult factory for super heavy duty tier stands.

For Conveyor Width In	Over-All Width In	Over-All Height In	Model No 2 Tiers	Model No 3 Tiers	Model No 4 Tiers
12	17	60	TS-12-2	TS-12-3	TS-12-4
18	23	60	TS-18-2	TS-18-3	TS-18-4
24	29	60	TS-24-2	TS-24-3	TS-24-4
30	35	60	TS-30-2	TS-30-3	TS-30-4

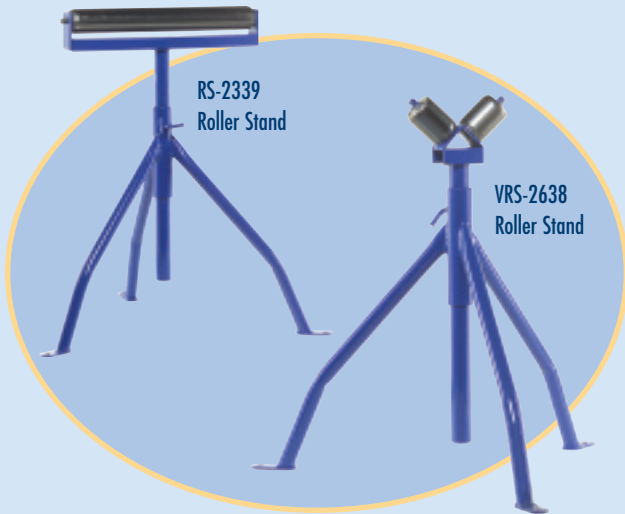

► **ROLLER STANDS**

The height of the roller stands can be adjusted to fit your particular applications. Highly portable. Can be used anywhere within a plant or warehouse. Strong and durable.

Roller Width In	Adjustable Height In	Capacity Lbs	Model No
16	23 to 39	300	RS-2339
16	28 to 50	300	RS-2850
4	26 to 38	400	VRS-2638

Electrical Controls



► **AC DRIVE CONTROLLER**
For 230-3 Phase and 460-3 Phase Motors



► **STARTER WITH ON/OFF SWITCH**
For 110-1-60 Motors



► **DC SPEED CONTROLLER**
For 1/4 - 1 HP DC Motors
110-1-60



Accordion Wheel Conveyor



Accordion Roller Conveyor

Accordion Conveyors

MEDIUM/HEAVY DUTY ACCORDION WHEEL CONVEYORS:

Flexible conveyors conform to the various shapes necessary for ease of product handling with lengths available up to 60 feet.

MEDIUM/HEAVY DUTY ACCORDION ROLLER CONVEYORS:

Flexible conveyors designed for packages with flat or irregular bottoms.

IMPACT CONVEYORS (FIXED): Aluminum channel rigid frame with steel wheels is bolted to the receiving end of the conveyor. Skate wheels on 3" axle centers withstand impact of heavy materials.

SWING STICK: 5' rigid frame aluminum Swing Stick with 3" axle centers attaches to end of conveyor and extends up into truck beds. When not in use, it nests on top of conveyor.



Impact Conveyor

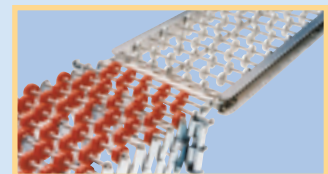

Swing Stick

MEDIUM DUTY ACCORDION WHEEL SPECIFICATIONS:

Load Capacity: 226 lbs. per lineal ft. when fully extended ♦ Standard Height Adjustment: 28" - 44" ♦ 1 Box Stop and 1 Set of Hook Couplers per unit ♦ Casters: 5" x 1-1/2" swivel with foot brake.

HEAVY DUTY ACCORDION WHEEL SPECIFICATIONS:

Load Capacity: 275 lbs. per lineal ft. when fully extended ♦ Double Cross Braces and Double Wall Inner Leg Supports ♦ 7 gauge side links with black epoxy finish ♦ Standard Height Adjustment: 28" - 36"

MEDIUM DUTY ACCORDION ROLLER SPECIFICATIONS:

Load Capacity: 200 lbs. per lineal ft. ♦ 1-3/8" O.D. Galvanized Steel Rollers on 5-1/4" Axle Centers ♦ 28" to 36" ♦ Box Stop, Pull Handle & Couplers Standard ♦ 5 x 1-1/2" Swivel/Wheel Lock Casters

► MEDIUM DUTY ACCORDION ROLLER CONVEYORS

LENGTH ADJUSTMENT WITH 5 1/4" AXLE CENTERS			18" WIDTHS		24" WIDTHS	
Length Contracted/Extended at Maximum	Leg Sets Per Unit	Bed Sections Per Unit	Model No	Rollers Per Section	Model No	Rollers Per Section
2' 7" - 8' 6"	3	2	RLR18008S	9	RLR24008S	9
3' 9" - 12' 2"	4	3	RLR18012S	9	RLR24012S	9
4' 10" - 15' 10"	5	4	RLR18016S	9	RLR24016S	9
5' 11" - 19' 6"	6	5	RLR18020S	9	RLR24020S	9
7' 0" - 23' 2"	7	6	RLR18024S	9	RLR24024S	9
8' 4" - 27' 9"	8	7	RLR18028S	9	RLR24028S	9
9' 5" - 31' 5"	9	8	RLR18032S	9	RLR24032S	9
10' 6" - 35' 1"	10	9	RLR18036S	9	RLR24036S	9
12' 5" - 41' 6"	12	11	RLR18040S	9	RLR24040S	9

► MEDIUM DUTY ACCORDION WHEEL CONVEYORS

LENGTH	5¼ AXLE CENTERS	14" WIDTHS		18" WIDTHS		24" WIDTHS	
		6 SKATE WHEELS/AXLE*		6 SKATE WHEELS/AXLE		8 SKATE WHEELS/AXLE	
Length Contracted/Extended at Maximum	Leg Sets Per Unit	Model No	Approx Wt Lbs	Model No	Approx Wt Lbs	Model No	Approx Wt Lbs
2' 4" – 8' 11"	3	214-08	160	218-08	190	224-08	220
3' 3" – 12' 10"	4	214-12	205	218-12	240	224-12	280
4' 3" – 16' 9"	5	214-16	260	218-16	310	224-16	360
5' 2" – 20' 9"	6	214-20	300	218-20	390	224-20	440
6' 2" – 24' 8"	7	214-24	350	218-24	420	224-24	500
7' 1" – 28' 7"	8	214-28	440	218-28	520	224-28	610
8' 1" – 32' 6"	9	214-32	480	218-32	570	224-32	680
9' 0" – 36' 6"	10	214-36	530	218-36	610	224-36	750
10' 0" – 40' 5"	11	214-40	580	218-40	690	224-40	830
10' 11" – 44' 4"	12	214-44	620	218-44	740	224-44	900
11' 11" – 48' 3"	13	214-48	690	218-48	820	224-48	990
12' 10" – 52' 3"	14	214-52	760	218-52	900	224-52	1080
13' 10" – 56' 2"	15	214-56	800	218-56	950	224-56	1140
14' 9" – 60' 1"	16	214-60	840	218-60	1000	224-60	1210

Please specify wheel type: N=Red Nylon P=Black Plastic S=Steel

► HEAVY DUTY ACCORDION WHEEL CONVEYORS

LENGTH	5¼ AXLE CENTERS	18" WIDTHS		24" WIDTHS		30" WIDTHS	
		6 SKATE WHEELS/AXLE		9 SKATE WHEELS/AXLE		12 SKATE WHEELS/AXLE	
Length Contracted/Extended at Maximum	Leg Sets Per Unit	Model No	Approx Wt Lbs	Model No	Approx Wt Lbs	Model No	Approx Wt Lbs
2' 7" – 8' 7"	3	418-08	220	424-08	250	430-08	290
3' 8" – 12' 3"	4	418-12	270	424-12	320	430-12	370
4' 8" – 15' 11"	5	418-16	350	424-16	420	430-16	500
5' 8" – 19' 7"	6	418-20	420	424-20	490	430-20	580
6' 8" – 23' 3"	7	418-24	470	424-24	560	430-24	650
8' 2" – 28' 0"	8	418-28	600	424-28	700	430-28	830
9' 2" – 31' 8"	9	418-32	660	424-32	770	430-32	910
10' 3" – 35' 4"	10	418-36	720	424-36	840	430-36	990
12' 1" – 41' 10"	12	418-40	850	424-40	1000	430-40	1180
13' 1" – 45' 6"	13	418-44	910	424-44	1070	430-44	1260
14' 4" – 49' 5"	14	418-48	1020	424-48	1200	430-48	1420
15' 4" – 53' 1"	15	418-52	1090	424-52	1270	430-52	1500
16' 5" – 56' 9"	16	418-56	1140	424-56	1340	430-56	1580
17' 5" – 60' 5"	17	418-60	1220	424-60	1440	430-60	1710

Please specify wheel type: N=Red Nylon P=Black Plastic S=Steel

► IMPACT CONVEYORS

Model No	Over-All Width	Over-All Length	Wheels Per Axle	Cross Braces	Conveyor	Width
IMPACT 17518	22"	46"	6	2	Model 226	18"
IMPACT 17524	28"	46"	9	2		24"
IMPACT 27518	22"	46"	6	4	Model 275 Roller 200	18"
IMPACT 27524	28"	46"	9	4		24"
IMPACT 27530	34"	46"	12	4		30"

► SWING STICK EXTENSION

Model No	Width	Skate Wheel	Wheels Per Axle
STK145.ON	14"	Nylon	6
STK145.OS	14"	Steel	6
STK185.ON	18"	Nylon	6
STK185.OS	18"	Steel	6
STK245.ON	24"	Nylon	9
STK245.OS	24"	Steel	9

Flo Rail Conveyors

Skate wheels mounted to various configurations of channels and angles comprise what is commonly known in the industry as flo rail conveyors. One of these may be adaptable to your unique system.

▶ FLOW RAIL CONVEYORS

Model No	Weight 10ft Section Lbs	Skate Wheel Centers In	Frame
FR-1	20	3	12 Gauge Galvanized Steel
FR-2	18	3	
FR-3	35	3	
FR-4	33	3	
FR-5	38	3	
FR-3-1.5	42	1½	
FR-4-1.5	40	1½	

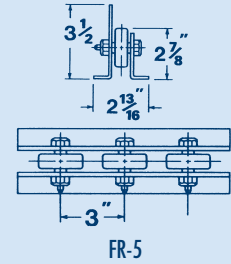
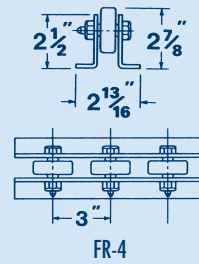
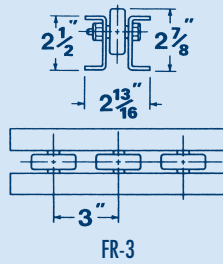
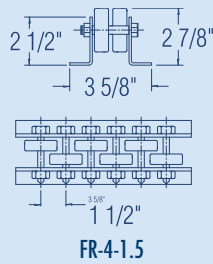
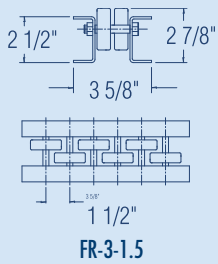
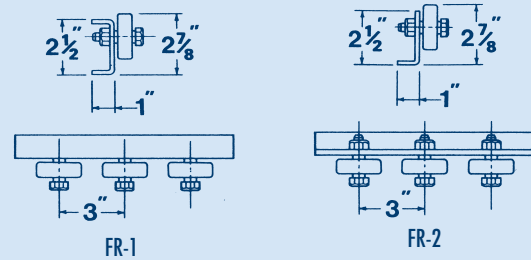
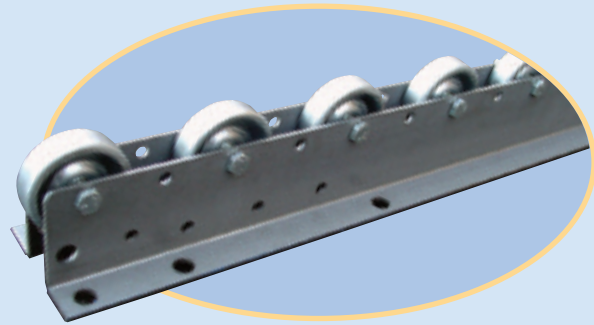

Gates

Manual or spring assisted gates can be used to provide access to personnel or equipment in other areas of the building. Used with skate wheel or roller conveyors. For special applications, consult factory.

▶ MANUAL GATES (HARDWARE ONLY)

For Conveyor Width	Standard Length Ft	For Conveyor Models	Model No
12	3' Maximum Recommended	1 3/8", 2" Skate Wheel Steel & Aluminum	MG-12
18			MG-18
24			MG-24

▶ SPRING ASSISTED GATES (HARDWARE ONLY)

For Conveyor Width	Standard Length Ft	For Conveyor Models	Model No
12	3' Maximum Recommended	1 3/8", 2" Skate Wheel Steel & Aluminum	SG-12
18			SG-18
24			SG-24

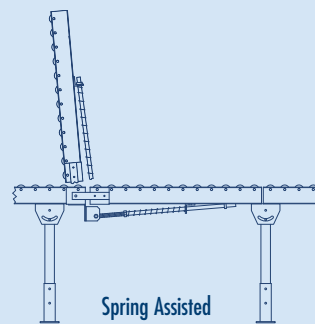

Spring Assisted

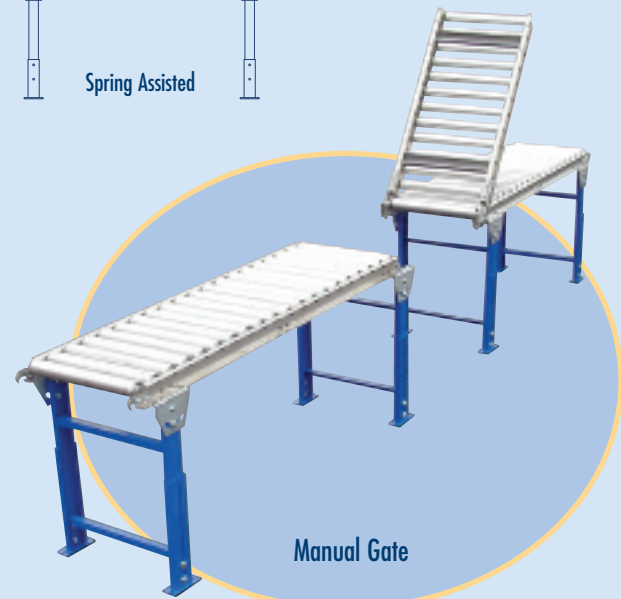

Manual Gate

Specialty Rollers

WHITE POLY COVER: Non-marking white poly, 1/16 to 1/8" thick. Available on 3/4", 1-3/8", 1.9", and 2" rollers. Good product protection.

RUBBER COVER: Black rubber coated roller is 1.9" O.D. and 1-5/8" I.D. with 7/16" hex spring loaded axle. Non-slip surface.

POLYURETHANE COVER: Polyurethane roller is a softer durometer for better product protection. 1/8" thick. Available on 1.9" and 2-1/2" O.D. rollers.

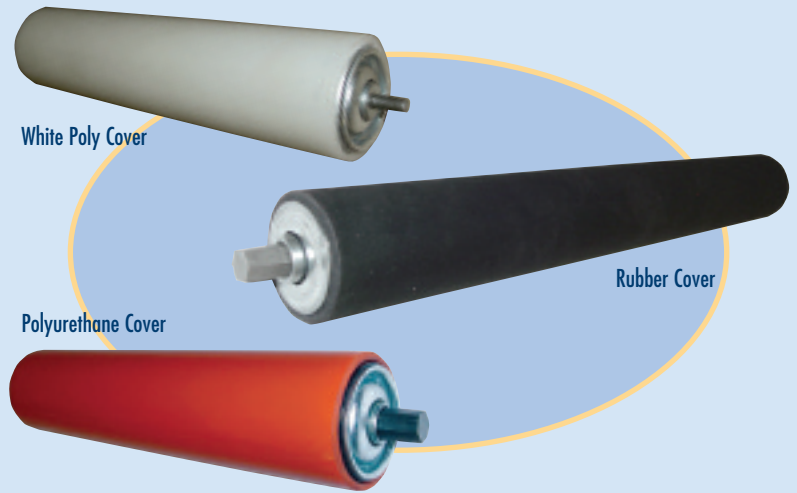

Chain Driven Live Roller Conveyors

This progressive chain driven live roller conveyor is used for heavy duty applications such as pallet moving and drum handling. Perfect for the steel and foundry industries.



CDLR SERIES SPECIFICATIONS:

3/4 HP 220/3/60 Motor ♦ 4" - 5.4 lbs./ft. ♦ 6" Structural Channel Construction ♦ 2-1/2" - 11 Ga. Rollers ♦ 6" Roller Centers ♦ No. 60 Chain, Roller to Roller Drive ♦ 40 FPM: Closer centers available

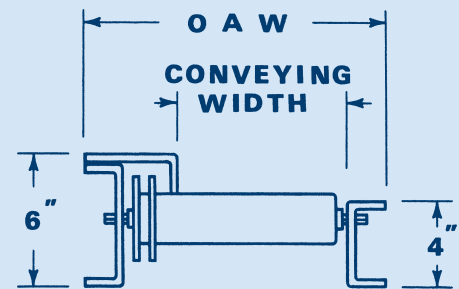
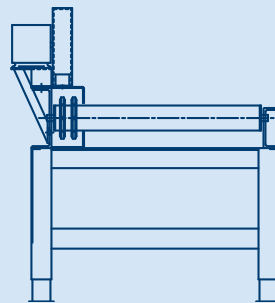
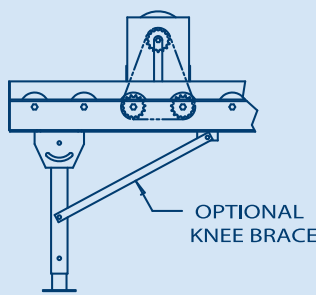

► CDLR SERIES

Model No	Over-All Width In	Usable Width In	Between Rail Width In	WEIGHT					
				Over-All Length: 5 Ft	Over-All Length: 10 Ft	Over-All Length: 15 Ft	Over-All Length: 20 Ft	Over-All Length: 25 Ft	Over-All Length: 30 Ft
CDLR-28	28	21	24	407	710	1013	1317	1620	1923
CDLR-34	34	27	30	436	757	1079	1400	1722	2043
CDLR-40	40	33	36	480	840	1172	1560	1920	2279
CDLR-46	46	39	42	524	920	1319	1796	2115	2512
CDLR-55	55	48	51	679	1010	1478	2056	2336	2764

Slimline & Mini-veyors

Economical units designed for light duty applications. Ideal for small parts handling where space is limited. The slimline conveyor side guard construction is perfect for transporting materials in confined spaces, while the mini-veyor has no guard rail. Can be used for assembly line operation. Stainless frame available.

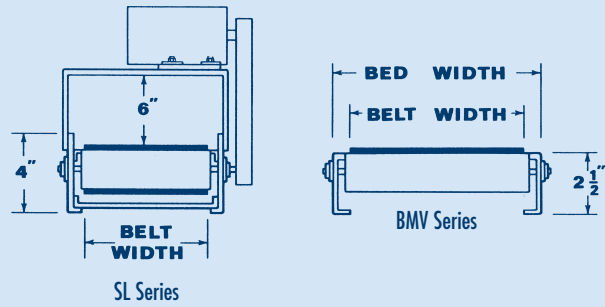

SL SERIES

Model No	Belt Width In	Bed Width In	WEIGHT	
			5 Ft Lbs	10 Ft Lbs
SL-06	6	7	150	255
SL-12	12	13	190	323
SL-18	18	19	225	382
SL-24	24	25	270	458

BMV SERIES

Model No	Belt Width In	Bed Width In	WEIGHT	
			5 Ft Lbs	10 Ft Lbs
BMV-06	6	7	148	251
BMV-12	12	13	186	316
BMV-18	18	19	220	374
BMV-24	24	25	264	448

SL & BMV SERIES SPECIFICATIONS:

1/4 HP 110/1/60 Gear Motor ♦ 14 Ga. Formed Bed ♦ 3 Ply Brown Neoprene Belt ♦ 60 FPM Standard ♦ 2" Drive Pulley ♦ Capacity: 100 lbs. Other Speeds Available ♦ See page 21 for electrical controls

For electrical controls see page 21.

Parts-veyors

This inclined conveyor moves product from one level to the next. The cleated belt keeps the material from tumbling under extreme incline positions.

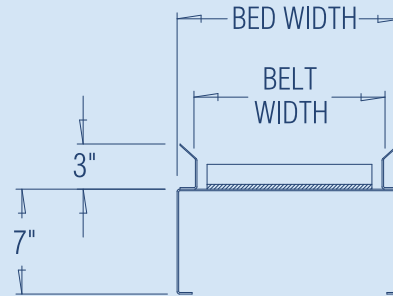

PBV SERIES SPECIFICATIONS:

1/4 to 1/2 HP 110/1/60 Gear Motor ♦ 14 Ga. Formed Bed ♦ 60 FPM ♦ 4" Drive Pulley ♦ 1-1/2" High Cleats on 12" Centers ♦ Top Mounted End Drive ♦ Black PVC Belt

For electrical controls see page 21.

PBV SERIES

Model No	Belt Width In	Bed Width In	WEIGHT			
			Over-All Length: 5 Ft	Over-All Length: 7 Ft	Over-All Length: 9 Ft	Over-All Length: 11 Ft
PBV-08	8	12	440	485	530	574
PBV-12	12	16	480	522	564	605
PBV-16	16	20	585	635	685	735

Slider Bed Conveyors

Powered conveyors for an unlimited variety of products; small parts, containers or cartons. Used in packaging, shipping and assembly. An economical method of moving medium weight products.

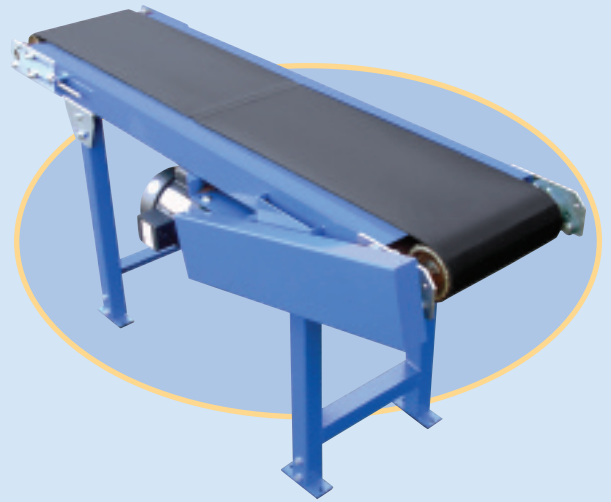
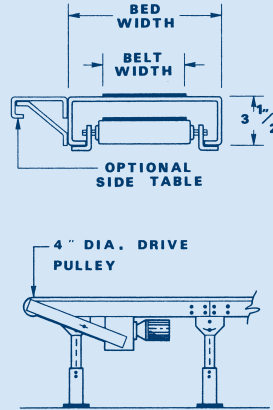

SB SERIES SPECIFICATIONS:

1/2 HP 220/3/60 Motor ♦ 12 Ga. Formed Bed 3-1/2" Deep ♦ Black PVC Belt ♦ 60 FPM Standard ♦ 4" Drive Pulley ♦ Capacity: 300-900 lbs.

For electrical controls see page 21.

► SB SERIES

Model No	Belt Width In	Bed Width In	WEIGHT					
			Over-All Length: 5 Ft	Over-All Length: 10 Ft	Over-All Length: 15 Ft	Over-All Length: 20 Ft	Over-All Length: 25 Ft	Over-All Length: 30 Ft
SB-12	12	16	261	305	370	413	478	523
SB-16	16	20	292	355	442	505	592	655
SB-18	18	22	301	368	462	529	623	690
SB-20	20	24	332	386	483	553	650	720
SB-24	24	28	354	412	518	596	700	778
SB-30	30	34	380	450	560	640	760	830

Roller Bed Conveyors

This horizontal belt over roller conveyor has been designed to move products and materials from one department to the other. Each roller helps minimize belt friction, thus providing for greater capacities.

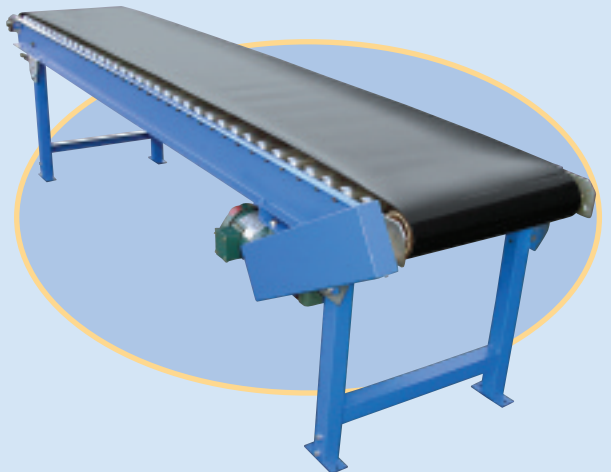
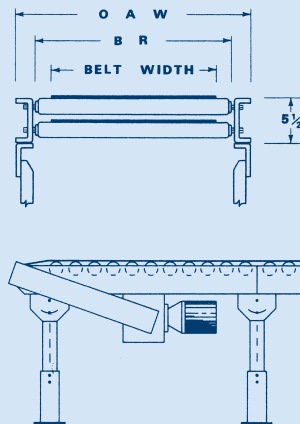

RB SERIES SPECIFICATIONS:

1/2 HP 220/3/60 Motor ♦ 1.9" 16 Ga. Rollers on 3" to 6" Centers ♦ 5-1/2" 10 Ga. Channel ♦ PVC Belt ♦ 60 FPM ♦ 4" Drive Pulley ♦ Capacity: 1000 lbs.

For electrical controls see page 21.

► RB SERIES

Model No	Belt Width In	Over-All Width In	WEIGHT					
			Over-All Length: 5 Ft	Over-All Length: 10 Ft	Over-All Length: 15 Ft	Over-All Length: 20 Ft	Over-All Length: 25 Ft	Over-All Length: 30 Ft
RB-12	12	18	250	325	405	490	569	625
RB-16	16	22	275	358	443	530	615	698
RB-18	18	24	288	378	468	558	648	738
RB-20	20	26	300	394	488	582	676	770
RB-24	24	30	323	428	533	638	743	848

Belt Driven Live Roller Conveyors

This economical belt driven live roller conveyor is ideal for moving boxes and packages where product positioning is necessary and accumulation is required.



BDLR SERIES SPECIFICATIONS:

1/2 HP 220/3/60 Motor ♦ 10 Ga. Construction ♦ 1.9" - 16 Ga. Galv. Rollers ♦ 3" Roller Centers ♦ Black PVC 120 Drive Belt ♦ 60 FPM ♦ 4" Drive Pulley Center Drive

For electrical controls see page 21.

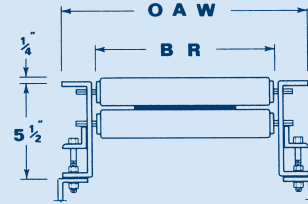
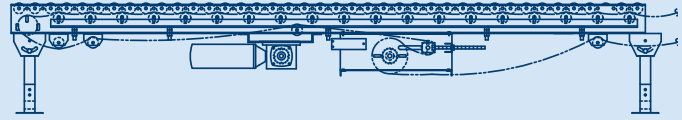

▶ BDLR SERIES

Model No	Over-All Width In	Between Rail Width In	Drive Belt Width In	WEIGHT				
				Over-All Length: 10 Ft	Over-All Length: 15 Ft	Over-All Length: 20 Ft	Over-All Length: 25 Ft	Over-All Length: 30 Ft
BDLR-12	12	9½	6	453	617	752	923	1050
BDLR-18	18	15½	6	543	707	842	1013	1140
BDLR-24	24	21½	8	637	832	997	1202	1360
BDLR-30	30	27½	12	727	963	1162	1392	1588
BDLR-36	36	33½	16	785	1057	1257	1522	1710
BDLR-42	42	39½	16	917	1222	1485	1782	2043

V-Belt Driven Curve Conveyors

Medium duty powered roller conveyor for use with our belt driven model. Can be slave driven. 6" Tangent Standard.



VBDLR SERIES SPECIFICATIONS:

1/2 HP 220/3/60 Motor ♦ 10 Ga. Frame ♦ 1.9" - 16 Ga. Galv. Rollers ♦ 3" Roller Centers ♦ V Belt Drive ♦ 60 FPM ♦ 36" Inside Radius ♦ Capacity: 300 lbs. distributed

For electrical controls see page 21.

▶ VBDLR SERIES

Model No	Over-All Width In	Between Rail Width In	Weight 45°	Weight 90°
VBDLR-12	12	9½	322	359
VBDLR-18	18	15½	350	381
VBDLR-24	24	21½	367	396
VBDLR-30	30	27½	398	427
VBDLR-36	36	33½	439	472
VBDLR-42	42	39½	482	510

Floor-To-Floor Incline Conveyors

This slider bed conveyor, designed for inclined operation, moves product from level to level or serves as a booster in a gravity system.

FFI SERIES SPECIFICATIONS:

3/4 HP 115/1/60 Motor ♦ 12 Ga. Formed Bed ♦ Rough-Top Belt ♦ 60 FPM Standard ♦ 4" Drive Pulley ♦ Capacity: 400 lbs ♦ Power Feeder Optional

For electrical controls see page 21.

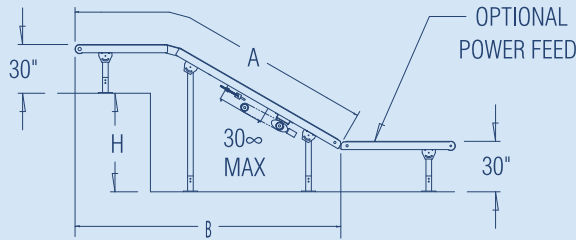
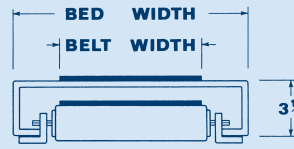

► FFI SERIES

Model No	Belt Width In	Bed Width In	Weight Lbs							
			665	700	810	846	884	920	972	1044
FFI-12	12	16	665	700	810	846	884	920	972	1044
FFI-18	18	22	850	892	1012	1055	1095	1136	1180	1270
FFI-24	24	28	980	1025	1064	1214	1256	1296	1340	1430
FFI-30	30	34	1120	1174	1354	1406	1456	1496	1548	1670
Over-All Length (A) Ft:			21	23	25	27	29	31	33	35
Height (H) Floor to Floor at 30° Ft:			8	9	10	11	12	13	14	15
Length of (B) at 30° Ft:			18	20	21	23	25	27	28	30

Wire Mesh Belt Conveyors

The wire mesh belt is virtually impervious to extreme heat and cold, and thus can transport components through ovens or freezers. For use in dry operations, scrap handling, and steam cleaning.

WMB SERIES SPECIFICATIONS:

1/2 HP 115/1/60 Motor ♦ 10 Ga. Construction ♦ 1" x 1" x 1/2" Wire Mesh Galv. Belt ♦ 6" Cast Iron Sprocket ♦ 60 FPM ♦ UHMW Wear Strips ♦ Capacity: 450 lbs.

For electrical controls see page 21.

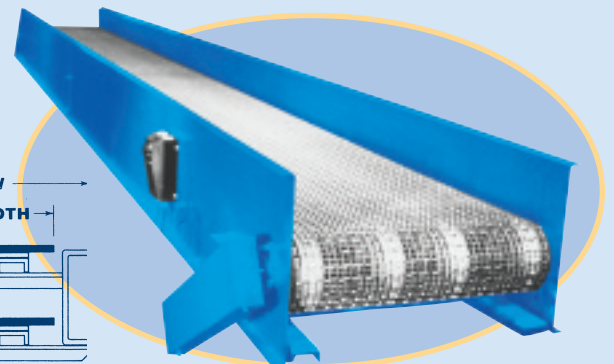
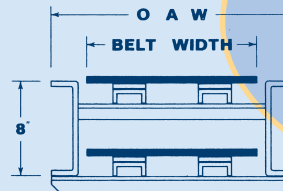

► WMB SERIES

Model No	Belt Width In	Bed Width In	WEIGHT					
			Over-All Length: 5 Ft	Over-All Length: 10 Ft	Over-All Length: 15 Ft	Over-All Length: 20 Ft	Over-All Length: 25 Ft	Over-All Length: 30 Ft
WMB-12	12	15	285	354	447	516	609	678
WMB-18	18	21	303	396	506	589	696	782
WMB-24	24	27	345	445	573	673	801	901

Flat-Top Chain Conveyors

These chain links have a flat surface and form a continuous belt. Conveys cans, bottles and similar units. Steel or stainless steel chain available.

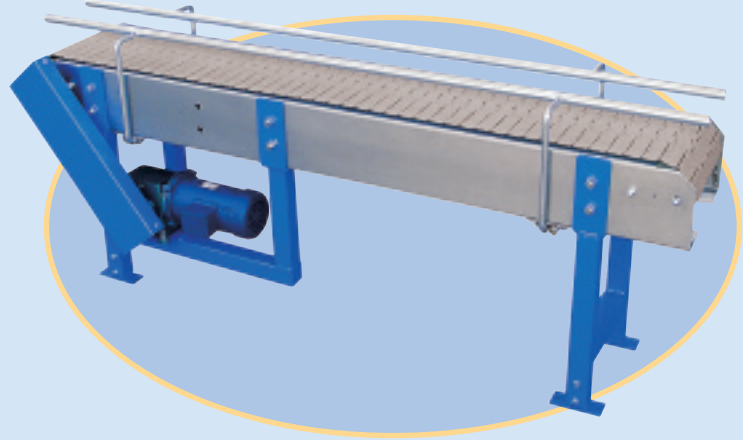
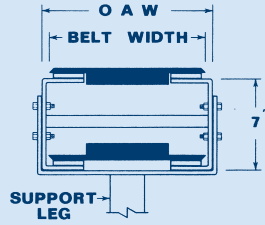

FTC SERIES SPECIFICATIONS:

1/2 HP 115/1/60 Motor ♦ 10 Ga. Construction ♦ 4" Plastic Chain with 1-1/2" Pitch ♦ 6" Plastic Sprocket ♦ 60 FPM ♦ Capacity: 300 lbs

► FTC SERIES

Model No	Chain Width In	Over-All Width In	WEIGHT					
			Over-All Length: 5 Ft	Over-All Length: 10 Ft	Over-All Length: 15 Ft	Over-All Length: 20 Ft	Over-All Length: 25 Ft	Over-All Length: 30 Ft
FTC-4	4	5	232	292	372	432	512	572
FTC-6	6	7	287	357	447	517	607	677
FTC-10	10	11	362	442	542	622	722	802
FTC-12	12	13	394	479	584	669	774	859

Multidirectional Wheel Conveyors

Referred to as "omni wheels", these multidirectional wheels will allow your packages to change directions on the proverbial dime.

SOW SERIES SPECIFICATIONS:

Wheels: 1.9", Solid Nylon ♦ Axles: 1/4" on 3" Centers
 ♦ Frame: 2-1/2" x 1" x 1", 12 Ga. Galv. Formed Channel ♦ Cross Braces
 ♦ Frame Cap. over 3' - 500 lbs. ♦ Wheel Cap. - 25 lbs.

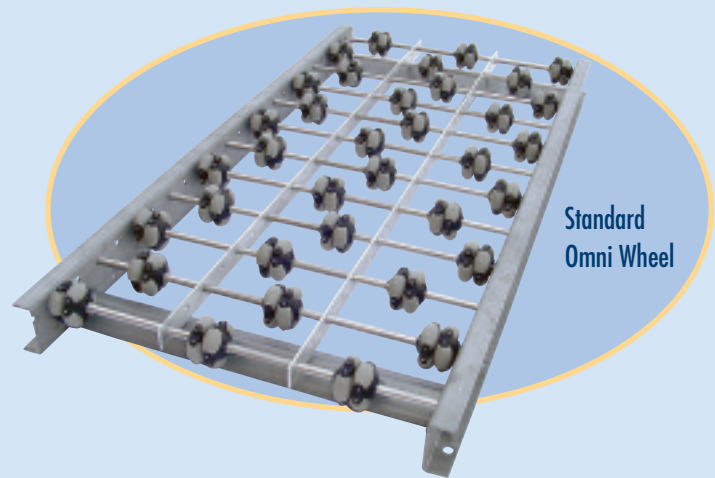

Standard Omni Wheel

► SOW SERIES

Over-All Width In.	Model No	Wheels Per Ft	Weight Per Ft Lbs	Over-All Length Ft
12	12-SOW-08-3	8	5	3
18	18-SOW-12-3	12	7	3
24	24-SOW-16-3	16	8	3
30	30-SOW-20-3	20	29	3

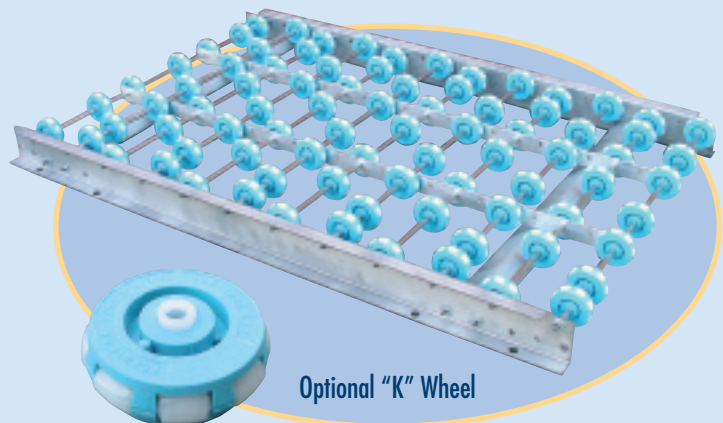

Optional "K" Wheel

Hopper-veyors

HV SERIES SPECIFICATIONS:

1/4 or 1/2 HP 115/1/60 Gear Motor ♦ .125 Alum. Formed Frame ♦ 6" Wide PVC Belt with 1" or 2" Cleats on 12" Centers ♦ 300 FPM ♦ 6" Pulleys ♦ Capacity: 300 lbs.

HV SERIES

MODEL NUMBER			Over-All Length Ft	Gear Motor Horsepower	Weight Lbs
Rough-Top Belting	1 Inch Rubber Cleats	2 Inch Rubber Cleats			
HV-08-RT	HV-08-RC-1	HV-08-RC-2	8	¼	240
HV-12-RT	HV-12-RC-1	HV-12-RC-2	12	¼	308
HV-16-RT	HV-16-RC-1	HV-16-RC-2	16	½	376
HV-20-RT	HV-20-RC-1	HV-20-RC-2	20	½	425

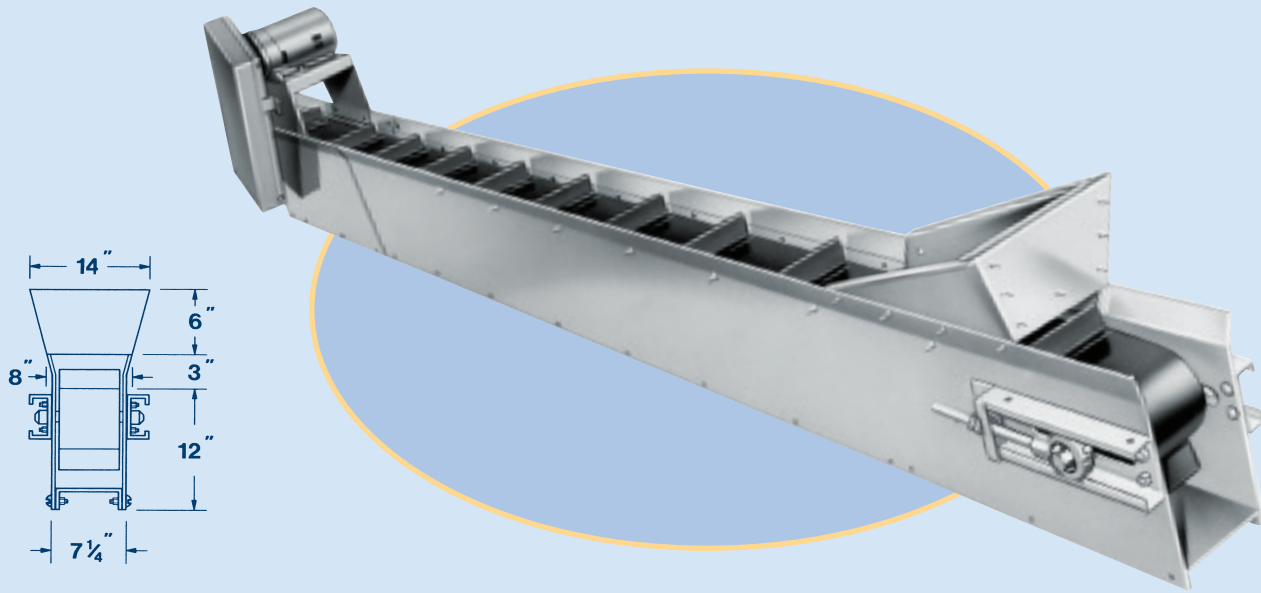

Pocket-veyors

This pocket-veyor design has taken every industry in the U.S.A. by storm. For product that must be contained within the belt.



PV SERIES SPECIFICATIONS:

1/2 HP 115/1/60 ♦ 11 Ga. Construction ♦ 120 PVC Belt ♦ 2" Cleats on 12" Centers ♦ 60 FPM ♦ 6" Pulleys ♦ Capacity: 300 lbs.

OPTIONAL STYLES

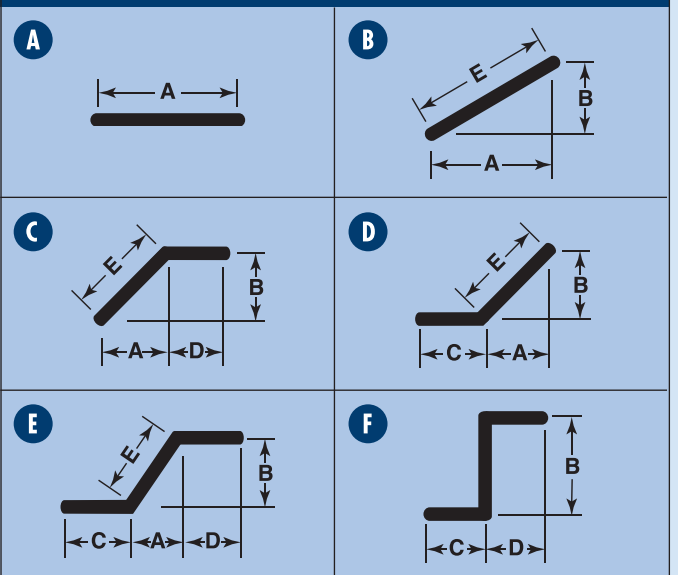

PV SERIES

Model No	Belt Width In	Frame Width In	Cleat Height In	Over-All Length Ft	Weight Lbs
PV-12	12	16	2	10	684
PV-18	18	22	2	10	818
PV-24	24	28	2	10	992

Chain-O-Flex Overhead Conveyors

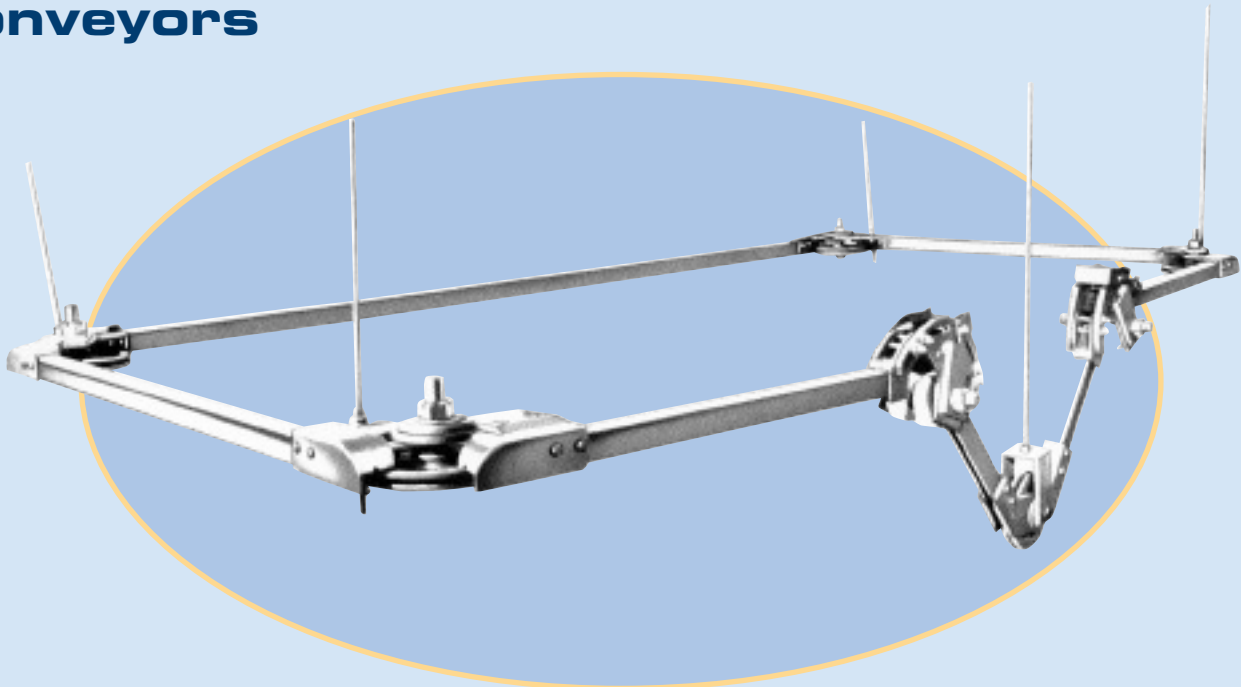

Modular • Bolted Construction • Do-It-Yourself • Floor Or Ceiling Mounted

The modular construction of the COF Series is a must for any progressive company. This unique construction allows for easy modification due to growth or product change, etc. This overhead conveyor is offered in standard lengths of 10 feet, but can be modified to any other size. These units can be suspended from the ceiling or are self-standing.

The fact that it has fewer moving parts lends itself to long life and virtually maintenance-free operation. This design works well in high heat conditions, such as powder or other paint applications. In excessive heat special bearings are available.

We also offer a multi-level installation. Other features include vertical dip hardware which allows for assembly, cleaning, and painting at various elevations. It has unlimited applications. If you have a particular requirement that does not lend itself to our standard system, consult factory for engineering assistance.

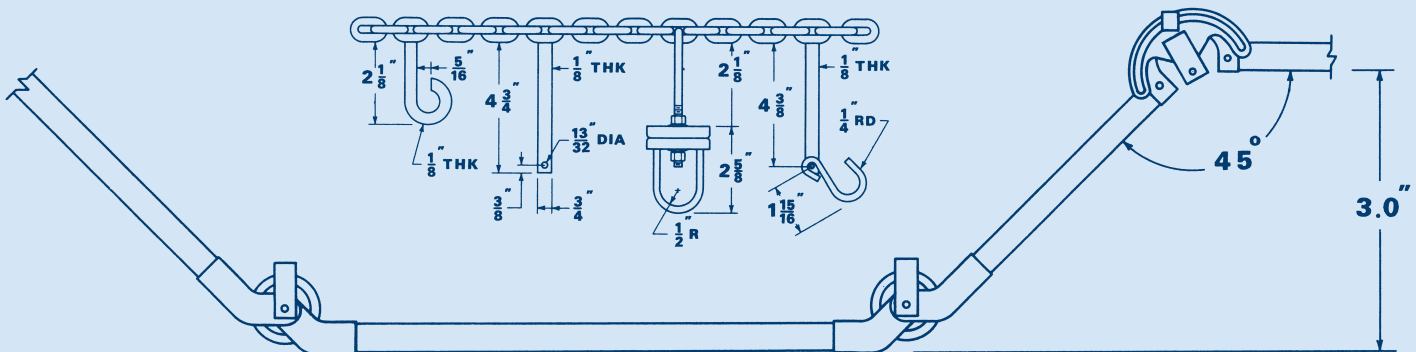

Chain-O-Flex Components

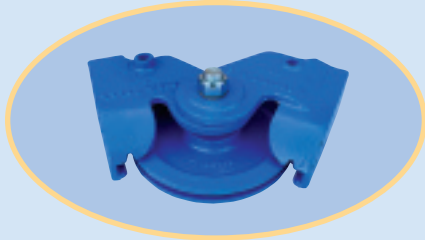

HORIZONTAL CORNER/MODEL 570:
The horizontal corners adjust from 20° to 180° which allows flexibility for your individual system.



OILER WITH HANGER/MODEL 540:
Pulsating oiler automatically lubricates chain.



TOP VERTICAL CORNER/MODEL 550:
This corner adjusts from 0° to 180° and is used when a change in elevation is required such as a dipping application.

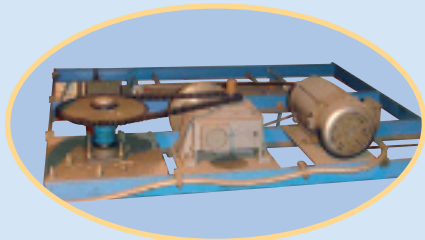
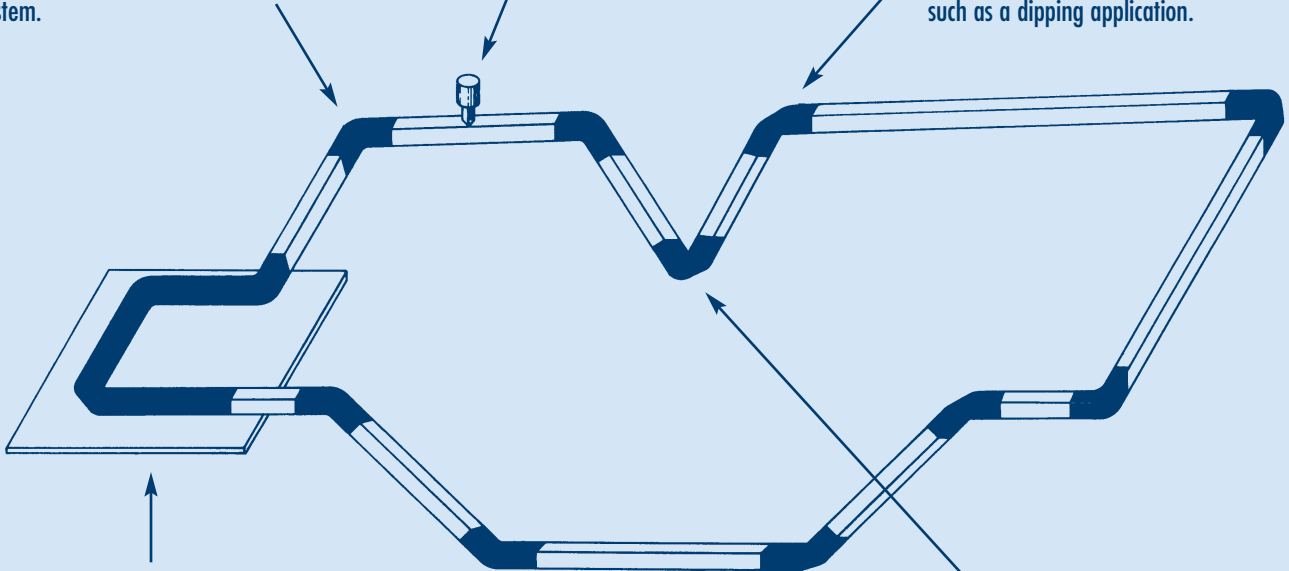

DRIVE UNIT/MODEL 5360: This standard universal drive unit comes with a 1 HP motor and a variable speed range from 4 to 12 FPM. Specialty voltage.



BOTTOM VERTICAL CORNER/MODEL 560: Bottom vertical also adjusts from 0° to 180°. Used to return product to higher level.

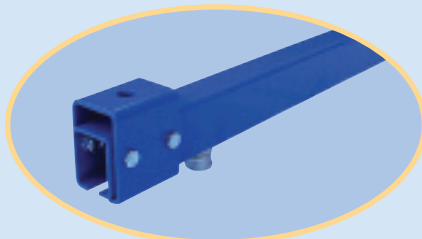

TRACK/MODEL 520: This 10 ga. heavy duty straight track is standard in 10 ft. lengths. Track length can be shortened to fit your exact requirements.

Wood Deck Platform Trucks

Since 1936, the name Roll-A-Way has been synonymous with quality in the materials handling industry. The outstanding features of our popular hardwood deck trucks reflect the reasons why. The wood platform is a solid 1-1/4" hardwood deck, sanded and double varnished for appearance, longer wear, and durability. Reinforced cross members lend additional support. The end racks are removable, constructed of thick wall pipe, and easily inserted into heavy pipe sockets. The casters (2 swivel and 2 rigid) are bolted to the cross members, are standard with 2 hardened ball bearing swivel raceways, lubrication fittings, and a selection of wheels. See price list for optional features such as bumpers, racks, wheels, and angle frames.



This platform truck has 8" wheels and a Style A end rack. A choice of wheels to suit any floor condition is available. 4", 5", and 6" wheels are optional.

AVAILABLE BUMPERS

		<p>SB Strip Bumper: Continuous rubber strip. Metal insert allows for permanent installation.</p>
		<p>CB Corner Bumper: Non-marking grey rubber protects all surfaces.</p>
		<p>HB Handle Bumper: Installed on handles of hand platform trucks.</p>

OPTIONAL RACK STYLES

<p>A</p> <p>Removable. One end rack with three slats.</p>	<p>B</p> <p>Removable. Two end racks with three slats.</p>
<p>C</p> <p>Removable. Economical. No slats.</p>	<p>D</p> <p>All removable. Two end racks. No slats.</p>
<p>E</p> <p>All removable. Four separate pipe handles.</p>	<p>F</p> <p>All removable. One end rack. Two pipe handles.</p>

WOOD DECK PLATFORM TRUCKS

Platform Size	Wheel Size/Type	Model No	Capacity Lbs	Weight Lbs	Platform Height	Standard End Rack	Optional Extras (Suffix)
22 x 40	8" x 2" Plexite Phenolic Resin	WD-2240-8UM	2200	100	12	Style A, One Rack, 3 Slats	All Listed End Racks —CB, Corner Bumper —SB, Strip Bumper —HB, Handle Bumper See Wheels Listed
24 x 48		WD-2448-8UM		110			
27 x 54		WD-2754-8UM		120			
30 x 60		WD-3060-8UM		130			
36 x 72		WD-3672-8UM		155			
22 x 40	8" x 2" Mold-On Rubber	WD-2240-8UV	2000	100			
24 x 48		WD-2448-8UV		110			
27 x 54		WD-2754-8UV		120			
30 x 60		WD-3060-8UV		130			
36 x 72		WD-3672-8UV		155			

Steel & Aluminum Deck Trucks

STEEL DECK: Steel deck platform trucks are constructed of 12 gauge steel. All parts are welded. Non-tilt type. Added cross member support. Removable end rack. 2 swivel and 2 rigid casters with 8" diameter wheels (4", 5" and 6" available). Powder coated blue. Option extras include rubber bumpers.

ALUMINUM DECK: Aluminum trucks are light weight, attractive, corrosion resistant, and non-toxic. the aluminum material is 3/16" thick (diamond tread) supported by full length angle and cross brace caster bolsters. Removable end racks. Ideal for institutional usage.

STAINLESS DECKS ALSO AVAILABLE

Lightweight aluminum deck trucks are ideal for sanitary conditions in which an easy-to-clean, rust-resistant conveyance is a must.



▶ STEEL & ALUMINUM DECK PLATFORM TRUCKS

Platform Size/Type	Wheel Size/Type	Model No	Capacity Lbs	Weight Lbs	Platform Height	Standard End Rack	Optional Extras (Suffix)
22 x 40 Steel	8" x 2" Plexite Phenolic Resin	SD-2240-8UM	2200	105	12	Style A, One Rack, 3 Slats	All Listed End Racks —CB, Corner Bumper —SB, Strip Bumper —HB, Handle Bumper See Wheels Listed
24 x 48 Steel		SD-2248-8UM		111			
27 x 54 Steel		SD-2754-8UM		127			
30 x 60 Steel		SD-3060-8UM		143			
36 x 72 Steel		SD-3672-8UM		176			
22 x 40 Aluminum		ADTP-2240-8UM	2000	64			
24 x 48 Aluminum		ADTP-2448-8UM		70			
27 x 54 Aluminum		ADTP-2754-8UM		75			
30 x 60 Aluminum		ADTP-3060-8UM		82			
36 x 72 Aluminum		ADTP-3672-8UM		96			

Wheel Options

A wide range of wheel types and sizes is available to suit every conceivable application and floor condition. When selecting a caster, always consider the wheel diameter for load weight, floor conditions, floor protection, and whether quiet operation is desired.



Payron Semi-Steel:
Machined Grey Iron



Payflex Cushion Rubber:
Non-marking Tread



Plexite Phenolic:
Macerated Canvas
Backing

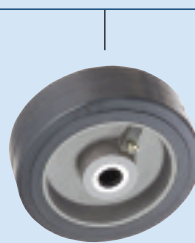

Mold-On Rubber:
Bonded to Metal Center



Mirakush:
85 D. Grey Polyurethane,
Injection Molded



Miratek:
95 D. Red Polyurethane,
Injection Molded

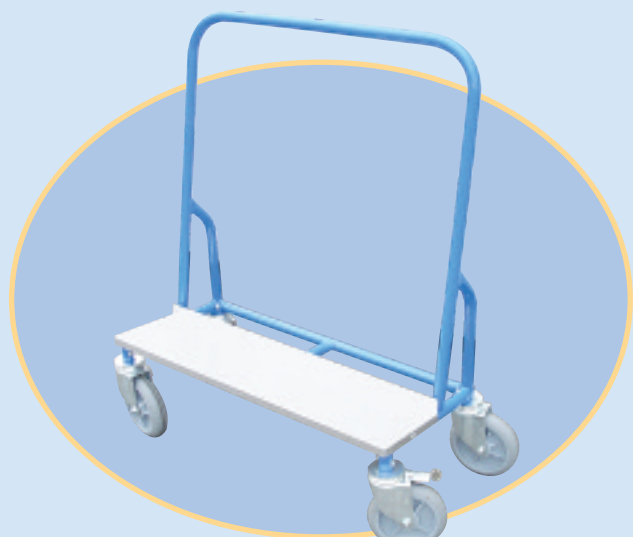

▶ **EXTRA STABLE DRYWALL TRUCK**

- Aluminum Deck
- 10 gauge tubular construction
- 40" x 18"
- 2000 lbs capacity
- Can ship UPS
- Patent Pending
- Four 8" swivel casters for moving in tight spaces, one with swivel lock for one man operation
- Model: ESDT1840



▶ **GRANITE HAND TRUCK**

For picking slabs of granite up directly off the floor.

- 1" pipe uprights
- 2" x 2" angle frame
- 1200 lbs capacity
- Four 4" polyurethane swivel casters
- 43" long x 22" wide
- Rubber bumpers to prevent scratching
- Model: GHT

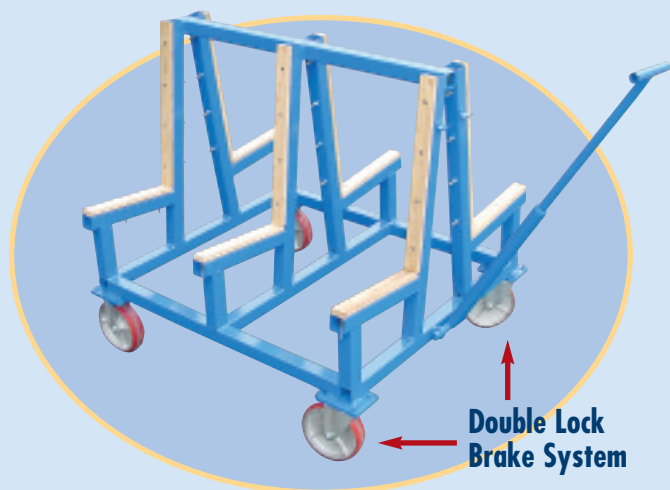

Double Lock Brake System

▶ **SUPER DUTY GRANITE TRUCK**

For moving heavy, large slabs of marble and granite.

- Two sided
- Constructed of 2" x 2" - 12 gauge tubing for extra strength
- Oak wear strips to prevent scratching
- 45" long x 42" wide
- Retractable handle
- 2 rigid casters, 2 swivel with double brake-locks swivel and wheel
- 4000 lbs capacity
- Model: SDGT

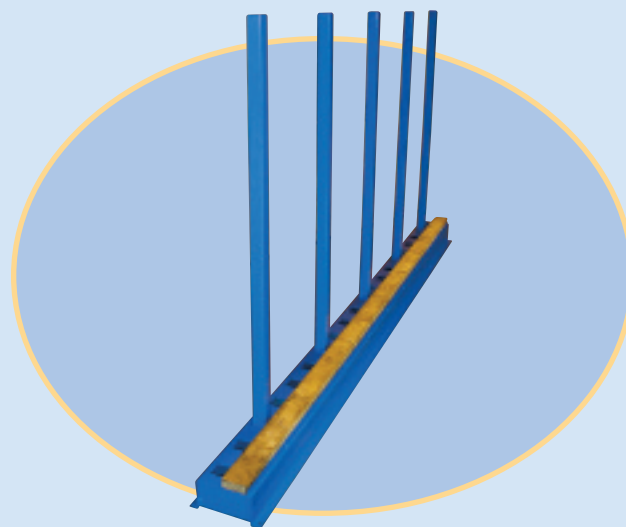

▶ **GRANITE STORAGE RACKS**

Ideal for storing marble, granite, and other heavy material.

- 2" 12 gauge square tubing with 5' uprights
- 2" x 4" wood bed for easy loading and unloading (wood not included)
- Approximate size of base: 6" x 6" x 10' long
- Mounting holes for permanent installation
- 2 sections required to make rack
- Model: GSR
- 10 uprights per unit



► **OP ORDER PICKING TRUCK**

2-sided truck has expanded metal, is all steel with welded construction, and has 6 separate compartments. Ideal for virtually any industry. 5" x 2" Payflex cushion tread wheels with roller bearings standard. Additional wheel types available. Bumpers optional. Powder Coated Blue. Overall height 48".

Over-All Dimensions	Wheel Size/Type	Model No	Capacity Lbs	Weight Lbs
30 x 48, 6 Shelves	5" x 2" Payflex Cushion Tread	OP-3048-5UX	1000	231
30 x 54, 6 Shelves		OP-3054-5UX		247
30 x 60, 6 Shelves		OP-3060-5UX		262



► **WS WAREHOUSE SHELF TRUCK**

Heavy duty shelf trucks. 12 gauge welded steel construction. 2 shelves are standard. 3 are optional. Standard shelves are flush with edges down; however, edges may be turned up. 8" x 2" Plexite wheels. Bumpers, optional wheels available. Stainless upon request. Powder coated grey. Overall height 36".

Over-All Dimensions	Wheel Size/Type	Model No	Capacity Lbs	Weight Lbs
24 x 48, 2 Shelves	8" x 2" Plexite Phenoic Resin	WS-2448-2-8UM	4000	169
24 x 60, 2 Shelves		WS-2460-2-8UM		188
34 x 48, 2 Shelves		WS-3448-2-8UM		205
34 x 60, 2 Shelves		WS-3460-2-8UM		235
34 x 72, 2 Shelves		WS-3472-2-8UM		260



► **UT UTILITY TRUCK**

These utility trucks are absolutely perfect for shipping and receiving areas. Note the writing space, and the separate compartment for bills of lading, etc. All steel, 16 gauge. 5" x 1-1/2" cushion rubber wheels. Optional with stainless steel. Bumpers available. Powder coated blue.

Over-All Dimensions w x l x h	Wheel Size/Type	Model No	Capacity Lbs	Weight Lbs
20 x 36 x 38	5" x 1 1/2" Payflex Cushion Tread	UT-2036-50X	700	91



► **BM BUILDING MATERIAL CARTS**

Sometimes referred to as lumber trucks, building material carts are excellent for transporting materials upright. 12 gauge steel deck and corner bumpers. 5" x 2" non-marking rubber wheels. Other wheels are available. Powder coated blue. Approximate height: 52"

Over-All Dimensions w x l x h	Wheel Size/Type	Model No	Capacity Lbs	Weight Lbs
24 x 36 x 52	5" x 2" Payflex Cushion Tread with Roller Brg	BM-2436-5UX	1000	140



► **BATTERY STANDS AND CARTS**

Minimize the manual handling of electric lift truck batteries. Use a Cart and Stand in tandem, or independently. Rugged steel construction. Conveyor rollers are 2" dia., 12 gauge steel, 4" on center, with 7/16" hex axles. Consult factory for specials. Powder coated blue.

Over-All Dimensions w x l x h	Wheel Used	Model No	Capacity Lbs	Weight Lbs	Roller Height
Battery Stand: 28 x 36 x 42	—	BS-283642	2600	165	6"-10" Adjustable
Battery Cart: 36 x 38 x 42 with 6" Roller Width	8" x 2" Plexite Phenolic	BC-3638-8UM	3000	398	25½"*

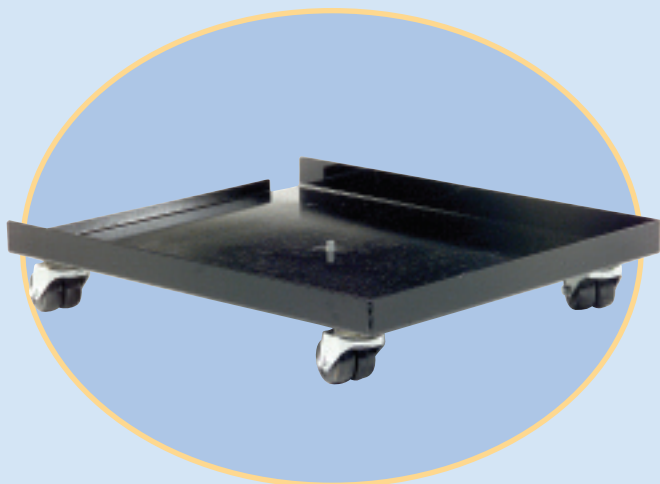

► **ELECTRONICS CABINET DOLLY**

12 gauge steel construction, 23-1/8" x 19-1/8" deck with 1-1/2" LIP on 3 sides. 5/8" lip on front side. Four hard rubber dual wheel swivel casters for stability and low over-all height. Ideal for hospital equipment, computer cabinets, sound equipment, and institutional use. Optional grounding chain available. Powder coated black.

Model No	Capacity Lbs	Weight Lbs
LPD 2319-20H-DW	800	20



► **MT MERCHANDISE TRUCK**

Merchandise trucks are equipped with 4 shelves, 8" x 2" Plexite phenolic resin wheels. 12 gauge all welded steel construction. Flush with edges down shelves are standard. Options include bumpers, optional wheels and stainless upon request. Powder coated grey. Overall height 60".

Over-All Dimensions	Wheel Size/Type	Model No	Capacity Lbs	Weight Lbs
24 X 48, 4 Shelves	8" x 2" Plexite Phenolic Resin	MT-2448-4-8UM	2000	230
24 x 60, 4 Shelves		MT-2460-4-8UM		268
30 x 60, 4 Shelves		MT-3060-4-8UM		319



► **ST SELECTOR TRUCK**

Selector trucks are all steel, 12 gauge steel construction. 2 shelves, with edges up, are standard; however, flush with edges down is optional. 5" x 1-1/2" cushion rubber wheels. Bumpers optional. Stainless steel available. Powder coated blue. Overall height 36".

Over-All Dimensions	Wheel Size/Type	Model No	Capacity Lbs	Weight Lbs
24 x 36, 2 Shelves	5" x 1 1/2" Payflex Cushion Tread	ST-2436-50X	800	99
24 x 48, 2 Shelves		ST-2448-50X		118
30 x 36, 2 Shelves		ST-3036-50X		116
30 x 48, 2 Shelves		ST-3048-50X		139



► **BT BINDERY TRUCK**

These 3-sided bindery trucks are all purpose. Rugged design, 12 gauge all welded steel construction. Understructure support is reinforced with angle iron frame. 8" x 2" Plexite phenolic resin wheels. Bumpers optional. Powder coated blue.

Over-All Dimensions w x l x h	Wheel Size/Type	Model No	Capacity Lbs	Weight Lbs
24 x 48 x 46	8" x 2" Plexite Phenolic Resin	BT-2448-8UM	2000	187
27 x 54 x 46		BT-2754-8UM		208
30 x 60 x 46		BT-3060-8UM		233



► **DW DRYWALL TRUCK**

These angle frame Drywall trucks transport wall board and other clumsy and oblong materials. 12 gauge all welded steel construction with reinforced understructure. 8" x 2" Plexite phenolic resin wheels standard. Bumpers optional. Powder coated blue.

Over-All Dimensions w x l x h	Wheel Size/Type	Model No	Capacity Lbs	Weight Lbs
30 x 60 x 58	8" x 2" Plexite Phenolic Resin	DW-3060-8UM	2500	201



► **GT GARMENT TRUCK**

These garment trucks are constructed of 1" pipe all welded construction. 5" x 1-1/2" Payflex non-marking cushion rubber wheels. Other wheels are available. Corner bumpers or continuous strip bumper are optional and render the GT ideal for institutional usage. Powder coated blue.

Over-All Dimensions w x l x h	Wheel Size/Type	Model No	Capacity Lbs	Weight Lbs
20 x 65 x 72	5" x 1 1/2" Payflex Cushion Tread	GT-2065-50X	750	94

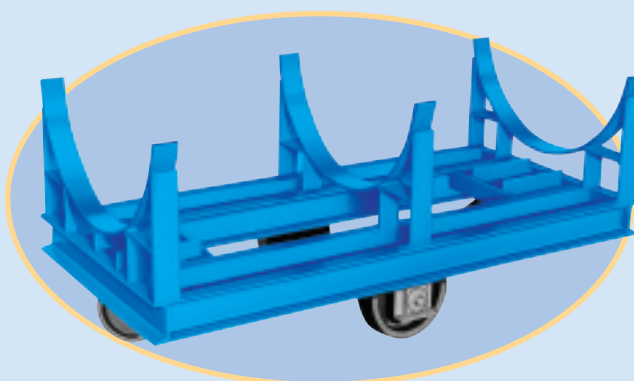

► **CT CRADLE TRUCK**

Obviously these cradle or bar stock trucks are designed to handle long bundles of steel, and may be used in conjunction with an overhead hoist or fork truck. 4" structural channel frame. Tilt type. 3, 4 and 5 cradles depending upon length. 5,000 lbs. capacity standard. Higher capacities available. Consult factory. Powder coated blue. Approximate height 25".

Over-All Dimensions	Wheel Size/Type	Model No	Capacity Lbs	Weight Lbs
28 x 60, 3 Cradles	10" x 3" Load, 8" x 2" Casters, Plexite	CT-2860-3-8UM	5000	305
28 x 96, 4 Cradles		CT-2896-4-8UM		400
28 x 120, 5 Cradles		CT-28120-5-8UM		475



► **SECURITY TRUCK**

Flattened 14 gauge expanded metal truck has 3/4" opening for visibility. 14 gauge reinforced deck and shelf with 1-1/2" angle uprights. Two doors may be secured with padlock. Two rigid and two swivel 5" phenolic casters. Extra shelves available. Powder coated blue.

Over-All Dimensions w x l x h in	Model No	Capacity Lbs	Weight Lbs
30 x 48 x 57	VOP-3048-5UM	1000	204
24 x 48 x 57	VOP-2448-5UM	1000	186



► **ALL PURPOSE FURNITURE DOLLY**

Cast iron construction.

Diameter In	Type	Cap Each Lbs	Model No	Weight Lbs	Casting Dimensions
2	Payflex	225	640-20X	6 3/4	9 1/2 x 9 1/2 x 9 1/2 with 3 1/2 O.D. recessed triangular center
	Payrock	300	640-20H		
2 1/2	Payflex	300	640-2 1/2 OX	6 7/8	
	Payrock	400	640-2 1/2 OH		
3	Payflex	375	640-30X	7	
	Payrock	630	640-30H		



► **LOW PAN TRUCK**

Constructed of 12 gauge steel with 1-1/2" side flanges. Removable handle extends 27" above the deck. Height to top of flange is 8". Two rigid and two swivel 5" rubber casters. Powder coated blue.

Over-All Dimensions w x l x h in	Model No	Capacity Lbs	Weight Lbs
20 x 30 x 6 1/2	LP-2030	800	50
24 x 36 x 6 1/2	LP-2436	800	58



► **SHOP CART**

Deep shelved carts are handy for all bulky parts. 16 gauge shelves are available in 3" or 6" deep models. Two rigid and two swivel 4" casters. Powder coated blue.

Over-All Dimensions w x l x h in	Model No	Capacity Lbs	Weight Lbs
30 x 16 x 32	SC-3016-3-40X	600	50
36 x 24 x 32	SC-3624-6-40X	800	88

Custom Fabrication

If you don't see what you need in our catalog, consult the factory for the design and engineering of the specific model that will get the job done. Here are some examples of specialty items we have built to suit various custom fit jobs.

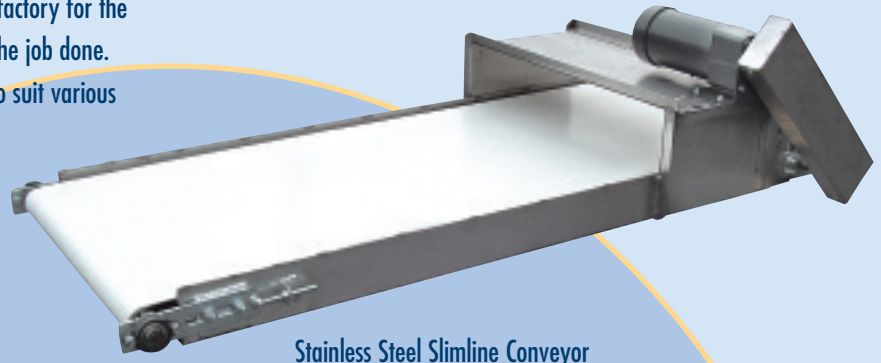

Stainless Steel Slimline Conveyor



34 Ton Dolly

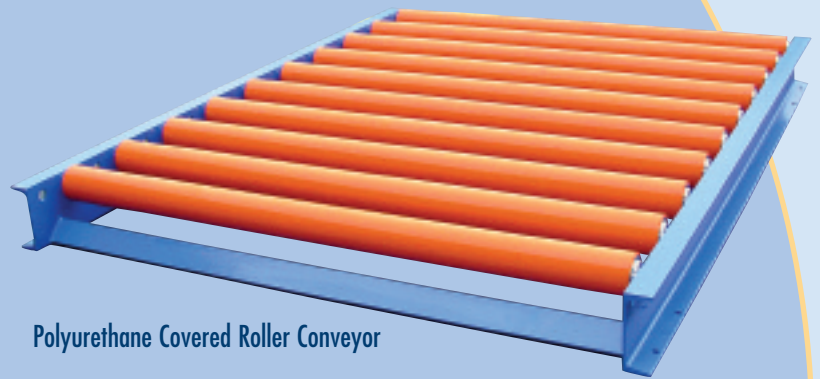

Polyurethane Covered Roller Conveyor

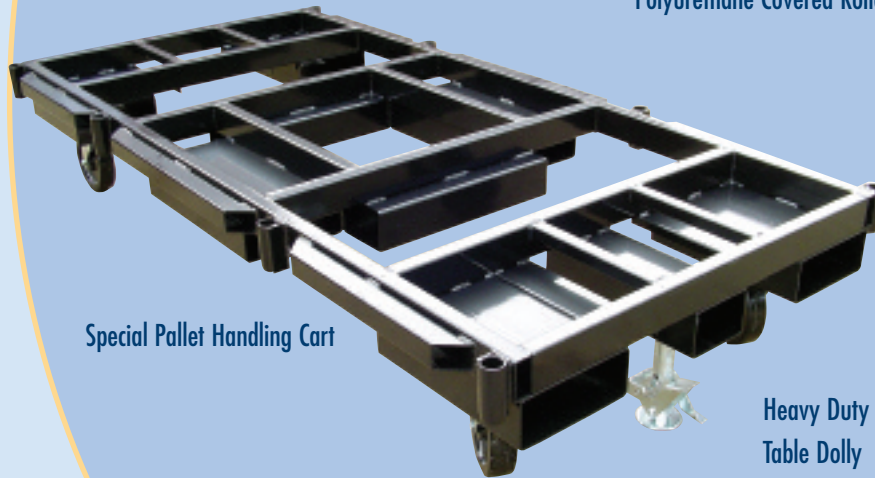

Special Pallet Handling Cart



Heavy Duty Turn Table Dolly

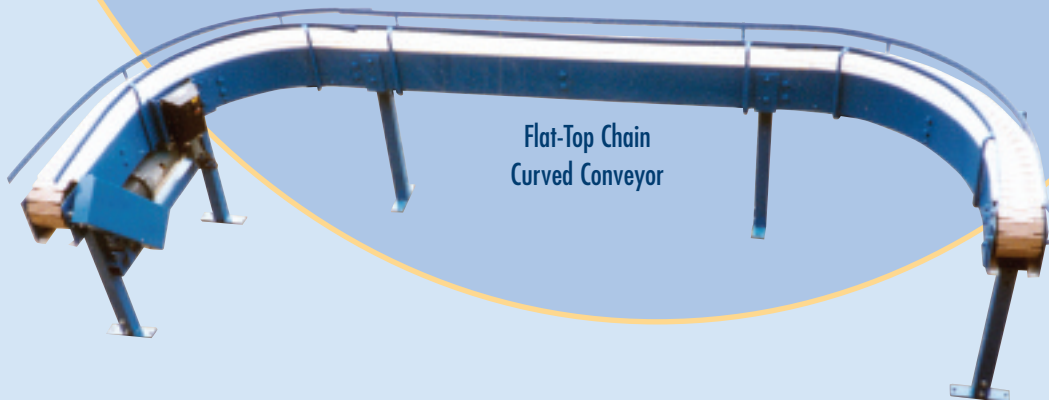

Flat-Top Chain Curved Conveyor



Powder Coating Services

Since 1936 Roll-A-Way Conveyors has been dedicated to producing the most complete selection of conveyors in the world. Today, Roll-A-Way adds powder coating services to its impressive list of capabilities. Roll-A-Way will powder coat for your company and we invite you to have us quote the parts you need painted.

FEATURES & BENEFITS:

The state-of-the-art powder coating system consists of a three stage pretreatment washer and a combination dry-off and cure oven that can reach temperatures of 500 degrees. Roll-A-Way can coat parts up to 3.5' wide, 6' in height, and 10' long in any high volume. The system is entirely automated with American Overhead's Cableway System, carrying the load at 4.5' per minute over a 457' path.

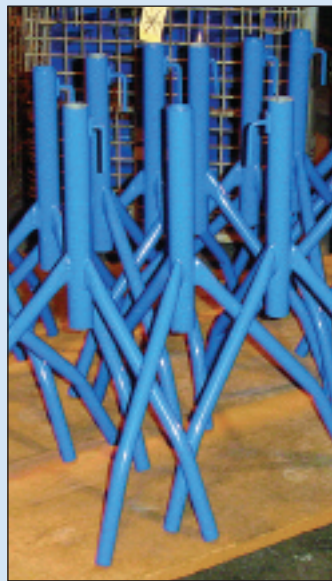

Where To Find Us

Roll-A-Way & American Overhead Conveyors

2335 Delaney Road, Waukegan, IL 60031

Phone: 847-336-5033

Email: roll-a-way@roll-away.com

Payson Bronco

6900 Cherry Avenue, Long Beach, CA 90805

Phone: 562-602-2400

Payson Casters

2323 Delaney Road, Waukegan, IL 60031

Toll Free: 800-323-4552

Phone: 847-336-6200 Fax: 847-336-6542

Payson Texas

2688 Freewood Drive, Dallas, TX 75220

Phone: 212-352-1765

Nagel Chase Pulleys

2337 Delaney Road, Waukegan, IL 60031

Toll Free: 800-323-4552

Phone: 847-336-4494

Payson Georgia

5034 Singleton Road, Norcross, GA 30093

Phone: 770-923-7753



ROLL-A-WAY
CONVEYORS, INC

2335 Delaney Road, Gurnee Illinois 60031
Toll Free: 800.747.9024 • Local: 847.336.5033 • Fax: 847.336.6542
www.roll-away.com • Email: Roll-away@roll-away.com