

HARRINGTON
A **KITO** GROUP COMPANY



Below-The-Hook
and Material Handling Equipment

Working Harder For You

In 1876, Edwin Harrington dramatically improved the self-sustaining hoist by introducing the worm-gear design. Since then, the company he founded has earned a proud reputation for product innovations and consistent quality that our customers count on to meet their diverse requirements.

Over the years we have developed and grown by recognizing the value of our customers and responding to your needs. The daily mission of our organization is to provide you, the customer, with the highest quality in our products, service and support.

In addition to our superior products and expanded facilities, we offer a Sales and Customer Service team that is dedicated to serving you, a well qualified Engineering Department to support your technical needs and a full support staff who all know the importance of working together to provide solutions for your material handling projects.

We are working harder to be the supplier-of-choice for all of your hoist, crane, below-the-hook and material handling applications.

Table of Contents

LIFTING EQUIPMENT

03 - 30	LIFTING BEAMS
31 - 42	SPREADER BEAMS
43 - 48	ROLL LIFTERS
49 - 59	COIL LIFTERS
60 - 64	TONGS
65 - 69	SHEET LIFTERS
71 - 79	PALLET LIFTERS
81 - 86	FORK TRUCK ACCESSORIES
87 - 91	MATERIAL HANDLING
92 - 94	SAFETY GUIDELINES
95 - 98	INDEX

HSSLB

SHORT SPAN LIFTING BEAM
PLATE STYLE Page 4-5



HSDLB

STANDARD DUTY LIFTING BEAM
CHANNEL DESIGN Page 6-8



HSDLB

STANDARD DUTY LIFTING BEAM
I-BEAM DESIGN w/FLAME CUT BAIL Page 9-10



HSDLB

STANDARD DUTY LIFTING BEAM
I-BEAM DESIGN w/PIN BAIL Page 11



HBSLB

BASKET SLING LIFTING BEAM Page 12-14



HDCLB

DUAL CRANE LIFTING BEAM Page 15-16



HUNVB

UNIVERSAL LIFTING/SPREADER BEAM Page 17



HALB

ADJUSTABLE LIFTING BEAM Page 18



HABLB

ADJUSTABLE BAIL LIFTING BEAM Page 19-21



HLLB

LOAD LEVELING BEAM Page 22-23



HTPLB

THREE POINT LIFTING BEAM Page 24



HFPLB

FOUR POINT LIFTING BEAM Page 25



HFPSL

FOUR POINT SACK LIFTER BEAM Page 26



HFPAB

FOUR POINT ADJUSTABLE BEAM Page 27



HDCRB

DUAL CRANE ROTATING BEAM Page 28



HCGCLB

CHLORINE GAS CYLINDER LIFTING BEAM Page 29



HSSLB

SHORT SPAN LIFTING BEAM

PLATE STYLE



FEATURES

- This style of lifting beam is ideal for short span applications and can be utilized where headroom is limited.
- Supplied with a pair of shackles and one standard spread.
- Engineered and manufactured to ASME B30.20 & BTH-1 Design Category B Service Class 2.
- 100% of ALL lifting beams are Proof-Tested to 125% capacity and certificates supplied at No Additional Charge.
- Made in USA.

OPTIONS

- Additional lift points
- Higher capacities (supplied w/upper shackle)
- Additional lengths
- Upper shackle
- Upper shackle w/oblong link
- Hooks

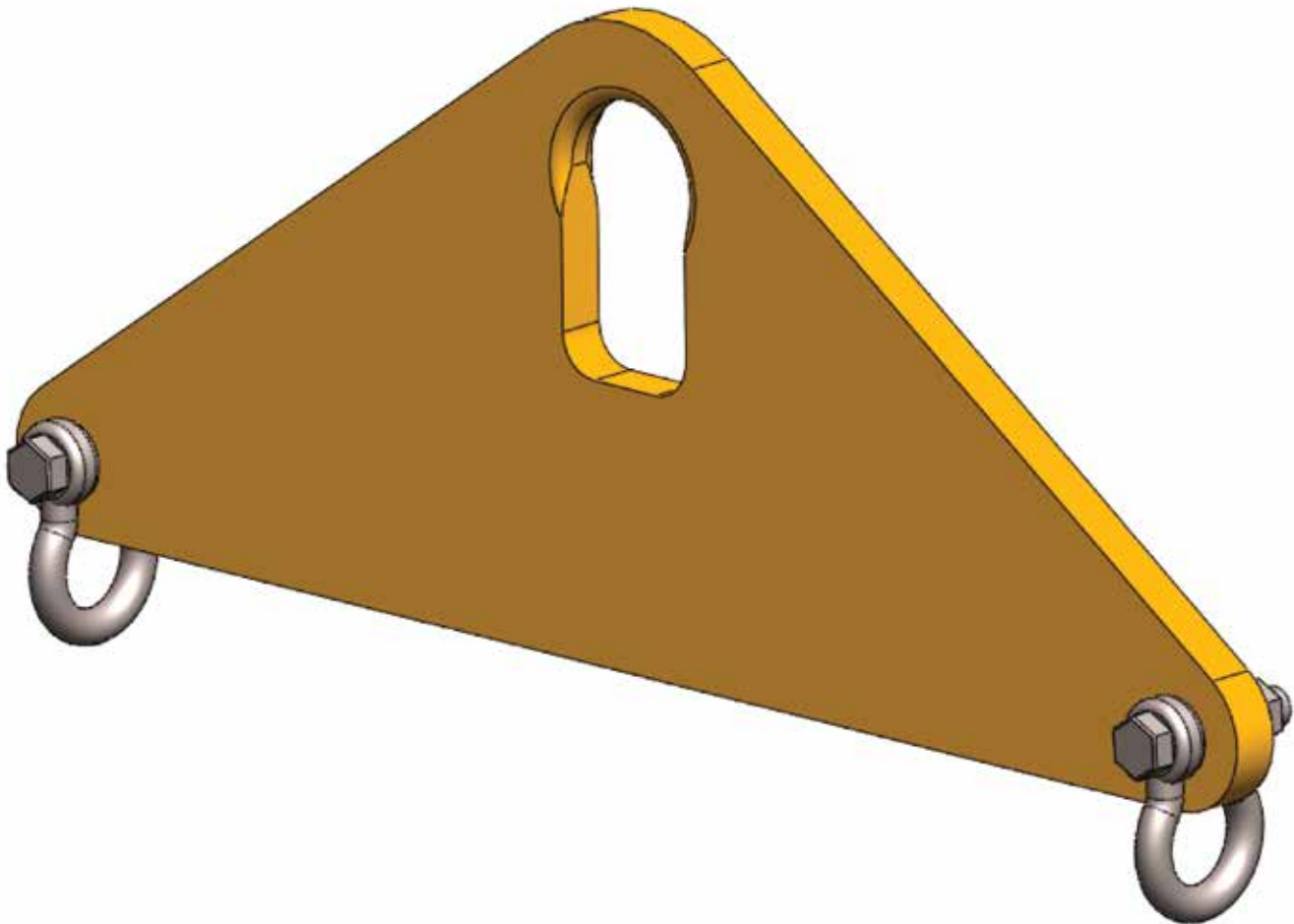

Optional Design With Upper Shackle

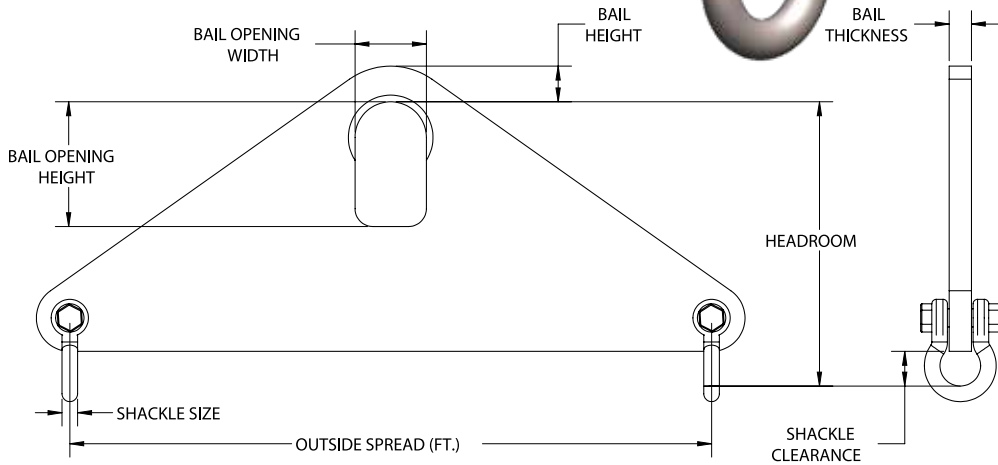
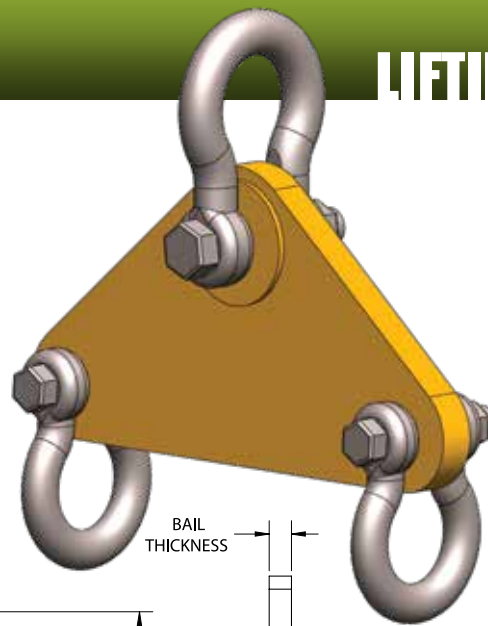

Model #	Capacity (US Tons)*	Outside Spread (Ft.)	Dimensions (Inches)							Weight (Lbs.)
			Headroom	Bail Height	Bail Opening Width	Bail Opening Height	Bail Thickness	Shackle Size	Shackle Clearance	
HSSLB-.25-1	1/4	1	6.9	0.63	2	4	0.50	3/8	0.9	10
HSSLB-.25-2	1/4	2	6.9	0.63	2	4	0.50	3/8	0.9	15
HSSLB-.25-3	1/4	3	6.9	0.63	2	4	0.50	3/8	0.9	25
HSSLB-1-1	1	1	9.6	0.88	3	5	0.75	5/8	1.6	20
HSSLB-1-2	1	2	9.6	0.88	3	5	0.75	5/8	1.6	40
HSSLB-1-3	1	3	9.6	0.88	3	5	0.75	5/8	1.6	50
HSSLB-3-1	3	1	10.8	1.25	3	5	1	3/4	1.8	40
HSSLB-3-2	3	2	10.8	1.25	3	5	1	3/4	1.8	60
HSSLB-3-3	3	3	10.8	1.25	3	5	1	3/4	1.8	80
HSSLB-10-2	10	2	16.1	2.00	4	7	1.25	7/8	2.1	110
HSSLB-10-3	10	3	16.1	2.00	4	7	1.25	7/8	2.1	140
HSSLB-20-2	20	2	20.1	2.50	5	9	1.50	1-1/4	3.1	160
HSSLB-20-3	20	3	20.1	2.50	5	9	1.50	1-1/4	3.1	220
HSSLB-40-2	40	2	29.5	3.50	7	16	2.50	1-3/4	4.5	420
HSSLB-40-3	40	3	29.5	3.50	7	16	2.50	1-3/4	4.5	550
HSSLB-50-2	50	2	31	3.63	7	16	2.50	1 3/4	4.5	440
HSSLB-50-3	50	3	31	3.63	7	16	2.50	1 3/4	4.5	565
HSSLB-70-2	70	2	34	4.00	7	18	3.00	2	4.8	620
HSSLB-70-3	70	3	34	4.00	7	18	3.00	2	4.8	795
HSSLB-110-2	110	2	40	5.25	8	20	3.50	2 1/2	7	960
HSSLB-110-3	110	3	40	5.25	8	20	3.50	2 1/2	7	1200
HSSLB-149-2	149	2	46	6.00	9	22	4.00	3	8.8	1050
HSSLB-149-3	149	3	46	6.00	9	22	4.00	3	8.8	1350
HSSLB-170-2	170	2	47.2	6.50	10	24	4.00	3	8.2	1150
HSSLB-170-3	170	3	47.2	6.50	10	24	4.00	3	8.2	1450
HSSLB-195-2	195	2	49.7	6.50	10	24	5.00	3 1/2	9.7	1780
HSSLB-195-3	195	3	49.7	6.50	10	24	5.00	3 1/2	9.7	2100

*1 US Ton = 2,000 lbs.



DO NOT EXCEED CAPACITY!
See the SAFETY GUIDELINES section before using these products. Pages 92–94.



HSDLB STANDARD DUTY LIFTING BEAM CHANNEL DESIGN

FEATURES

- This style of lifting beam can be utilized where headroom is limited and comes with a pair of swivel hooks and three standard spreads (3' and 4' beams have two standard spreads).
- Three standard lift points for load adjustment: outside lift point, middle lift point (outside less 1'), inside lift point (middle less 1').
- Engineered and manufactured to ASME B30.20 & BTH-1 Design Category B Service Class 2.
- 100% of ALL lifting beams are Proof-Tested to 125% capacity and certificates supplied at No Additional Charge.
- Made in USA.

OPTIONS

- Additional lift points
- Higher capacities
- Additional lengths
- Low headroom bail
- Additional hooks
- Shackle lugs
- Faspins
- Integrated beam stands

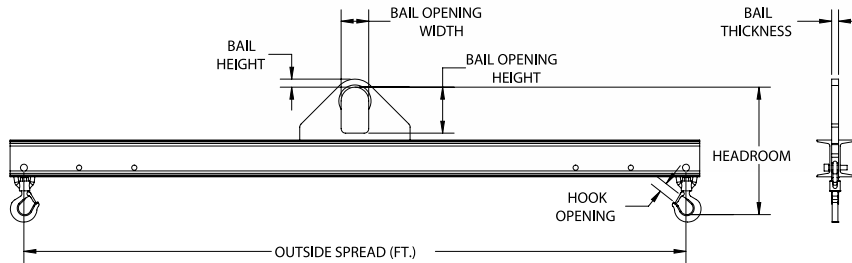
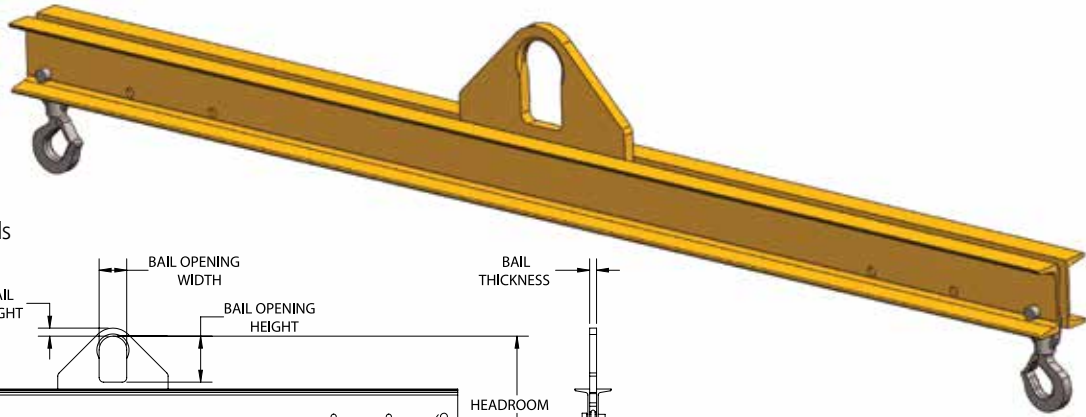

Model #	Capacity (US Tons)*	Outside Spread (Ft.)	Dimensions (Inches)						Weight (Lbs.)
			Headroom	Bail Height	Bail Opening Width	Bail Opening Height	Bail Thickness	Hook Opening	
HSDLB-1/2-3	1/2	3	13	0.88	3	5	0.75	0.91	40
HSDLB-1/2-4	1/2	4	13	0.88	3	5	0.75	0.91	50
HSDLB-1/2-6	1/2	6	13	0.88	3	5	0.75	0.91	65
HSDLB-1/2-8	1/2	8	13	0.88	3	5	0.75	0.91	80
HSDLB-1/2-10	1/2	10	14	0.88	3	5	0.75	0.91	125
HSDLB-1/2-12	1/2	12	14	0.88	3	5	0.75	0.91	145
HSDLB-1/2-14	1/2	14	15	0.88	3	5	0.75	0.91	210
HSDLB-1/2-16	1/2	16	16	0.88	3	5	0.75	0.91	360
HSDLB-1/2-18	1/2	18	17	0.88	3	5	0.75	0.91	465
HSDLB-1/2-20	1/2	20	18	0.88	3	5	0.75	0.91	490
HSDLB-1/2-24	1/2	24	20	0.88	3	5	0.75	0.91	765
HSDLB-1/2-30	1/2	30	22	0.88	3	5	0.75	0.91	1280
HSDLB-1-3	1	3	13	0.88	3	5	0.75	0.91	40
HSDLB-1-4	1	4	13	0.88	3	5	0.75	0.91	50
HSDLB-1-6	1	6	14	0.88	3	5	0.75	0.91	80
HSDLB-1-8	1	8	14	0.88	3	5	0.75	0.91	105
HSDLB-1-10	1	10	15	0.88	3	5	0.75	0.91	150
HSDLB-1-12	1	12	16	0.88	3	5	0.75	0.91	275
HSDLB-1-14	1	14	17	0.88	3	5	0.75	0.91	365
HSDLB-1-16	1	16	18	0.88	3	5	0.75	0.91	390
HSDLB-1-18	1	18	19	0.88	3	5	0.75	0.91	505
HSDLB-1-20	1	20	20	0.88	3	5	0.75	0.91	640
HSDLB-1-24	1	24	22	0.88	3	5	0.75	0.91	1025

*1 US Ton = 2,000 lbs.

cont.



STANDARD DUTY LIFTING BEAM - CHANNEL DESIGN cont.

Model #	Capacity (US Tons)*	Outside Spread (Ft.)	Dimensions (Inches)						Weight (Lbs.)
			Headroom	Bail Height	Bail Opening Width	Bail Opening Height	Bail Thickness	Hook Opening	
HSDLB-2-3	2	3	13	0.88	3	5	0.75	0.91	40
HSDLB-2-4	2	4	14	0.88	3	5	0.75	0.91	60
HSDLB-2-6	2	6	15	0.88	3	5	0.75	0.91	95
HSDLB-2-8	2	8	16	0.88	3	5	0.75	0.91	150
HSDLB-2-10	2	10	17	0.88	3	5	0.75	0.91	265
HSDLB-2-12	2	12	18	0.88	3	5	0.75	0.91	295
HSDLB-2-14	2	14	19	0.88	3	5	0.75	0.91	400
HSDLB-2-16	2	16	22	0.88	3	5	0.75	1.00	690
HSDLB-2-18	2	18	22	0.88	3	5	0.75	1.00	775
HSDLB-2-20	2	20	22	0.88	3	5	0.75	1.00	860
HSDLB-2-24	2	24	25	0.88	3	5	0.75	1.00	1665
HSDLB-3-3	3	3	14	1.25	3	5	1	1	55
HSDLB-3-4	3	4	15	1.25	3	5	1	1	80
HSDLB-3-6	3	6	16	1.25	3	5	1	1	155
HSDLB-3-8	3	8	17	1.25	3	5	1	1	225
HSDLB-3-10	3	10	18	1.25	3	5	1	1	260
HSDLB-3-12	3	12	20	1.25	3	5	1	1	400
HSDLB-3-14	3	14	22	1.25	3	5	1	1	620
HSDLB-3-16	3	16	22	1.25	3	5	1	1	705
HSDLB-3-18	3	18	26	1.25	3	5	1	1.36	1280
HSDLB-3-20	3	20	26	1.25	3	5	1	1.36	1420
HSDLB-3-24	3	24	26	1.25	3	5	1	1.36	1690
HSDLB-5-3	5	3	18	2	4	7	1.25	1.36	100
HSDLB-5-4	5	4	19	2	4	7	1.25	1.36	145
HSDLB-5-6	5	6	20	2	4	7	1.25	1.36	210
HSDLB-5-8	5	8	22	2	4	7	1.25	1.36	280
HSDLB-5-10	5	10	24	2	4	7	1.25	1.36	380
HSDLB-5-12	5	12	25	2	4	7	1.25	1.36	570
HSDLB-5-14	5	14	30	2	4	7	1.25	1.61	1045
HSDLB-5-16	5	16	30	2	4	7	1.25	1.61	1185
HSDLB-5-18	5	18	30	2	4	7	1.25	1.61	1325
HSDLB-5-20	5	20	30	2	4	7	1.25	1.61	1470
HSDLB-5-24	5	24	33	2	4	7	1.25	1.61	2320
HSDLB-7.5-3	7.5	3	21	2	4	7	1.25	1.61	130
HSDLB-7.5-4	7.5	4	22	2	4	7	1.25	1.61	170
HSDLB-7.5-6	7.5	6	24	2	4	7	1.25	1.61	235
HSDLB-7.5-8	7.5	8	25	2	4	7	1.25	1.61	320
HSDLB-7.5-10	7.5	10	27	2	4	7	1.25	1.61	495
HSDLB-7.5-12	7.5	12	30	2	4	7	1.25	1.61	900
HSDLB-7.5-14	7.5	14	30	2	4	7	1.25	1.61	1050
HSDLB-7.5-16	7.5	16	30	2	4	7	1.25	1.61	1190
HSDLB-7.5-18	7.5	18	33	2	4	7	1.25	1.61	1640
HSDLB-10-3	10	3	22	2	4	7	1.25	1.61	145
HSDLB-10-4	10	4	23	2	4	7	1.25	1.61	165
HSDLB-10-6	10	6	25	2	4	7	1.25	1.61	260
HSDLB-10-8	10	8	27	2	4	7	1.25	1.61	410
HSDLB-10-10	10	10	30	2	4	7	1.25	1.61	770
HSDLB-10-12	10	12	30	2	4	7	1.25	1.61	910
HSDLB-10-14	10	14	30	2	4	7	1.25	1.61	1055
HSDLB-10-16	10	16	33	2	4	7	1.25	1.61	1475
HSDLB-10-18	10	18	33	2	4	7	1.25	1.61	1985

*1 US Ton = 2,000 lbs.

cont.



DO NOT EXCEED CAPACITY!
See the SAFETY GUIDELINES section before using these products. Pages 92–94.



HSDLB

STANDARD DUTY LIFTING BEAM cont. CHANNEL DESIGN

FEATURES

- This style of lifting beam can be utilized where headroom is limited and comes with a pair of swivel hooks and three standard spreads (3' and 4' beams have two standard spreads).
- Three standard lift points for load adjustment: outside lift point, middle lift point (outside less 1'), inside lift point (middle less 1').
- Engineered and manufactured to ASME B30.20 & BTH-1 Design Category B Service Class 2.
- 100% of ALL lifting beams are Proof-Tested to 125% capacity and certificates supplied at No Additional Charge.
- Made in USA.

OPTIONS

- Additional lift points
- Higher capacities
- Additional lengths
- Low headroom bail
- Additional hooks
- Shackle lugs
- Faspins
- Integrated beam stands

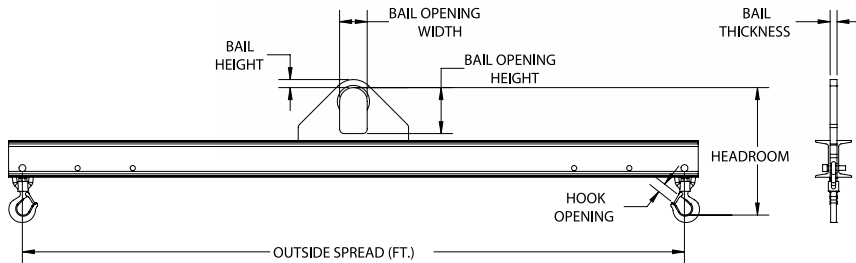
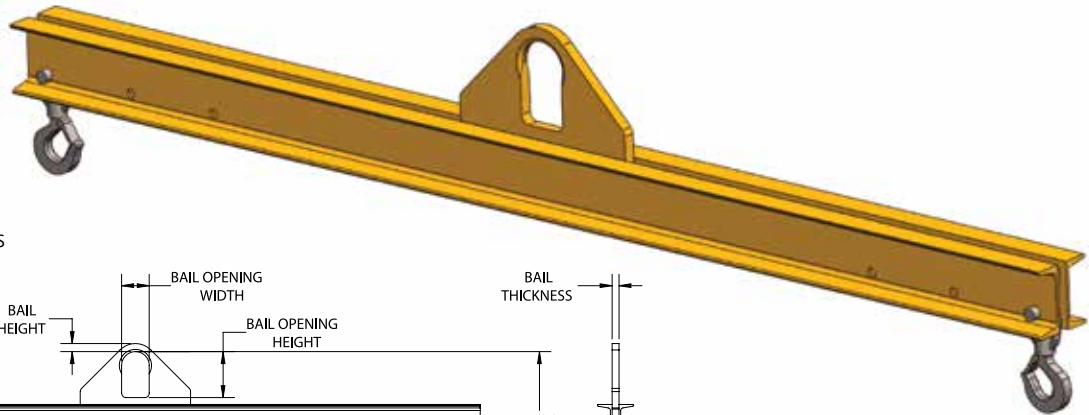

Model #	Capacity (US Tons)*	Outside Spread (Ft.)	Dimensions (Inches)						Weight (Lbs.)
			Headroom	Bail Height	Bail Opening Width	Bail Opening Height	Bail Thickness	Hook Opening	
HSDLB-15-3	15	3	26	2.5	5	9	1.5	2.08	190
HSDLB-15-4	15	4	28	2.5	5	9	1.5	2.08	255
HSDLB-15-6	15	6	30	2.5	5	9	1.5	2.08	385
HSDLB-15-8	15	8	33	2.5	5	9	1.5	2.08	700
HSDLB-15-10	15	10	33	2.5	5	9	1.5	2.08	835
HSDLB-15-12	15	12	37	2.5	5	9	1.5	2.08	1195
HSDLB-15-14	15	14	37	2.5	5	9	1.5	2.08	1460
HSDLB-20-3	20	3	29	2.5	5	9	1.5	2.27	235
HSDLB-20-4	20	4	31	2.5	5	9	1.5	2.27	320
HSDLB-20-6	20	6	34	2.5	5	9	1.5	2.27	575
HSDLB-20-8	20	8	34	2.5	5	9	1.5	2.27	710
HSDLB-20-10	20	10	35	2.5	5	9	1.5	2.27	840
HSDLB-20-12	20	12	38	2.5	5	9	1.5	2.27	1585
HSDLB-25-4	25	4	38	3	6	12	1.75	3.02	415
HSDLB-25-6	25	6	41	3	6	12	1.75	3.02	680
HSDLB-25-8	25	8	41	3	6	12	1.75	3.02	815
HSDLB-25-10	25	10	44	3	6	12	1.75	3.02	1462
HSDLB-25-12	25	12	44	3	6	12	1.75	3.02	1700
HSDLB-30-4	30	4	45	3.5	7	16	2	3.02	655
HSDLB-30-6	30	6	45	3.5	7	16	2	3.02	790
HSDLB-30-8	30	8	48	3.5	7	16	2	3.02	1330
HSDLB-40-4	40	4	45	3.5	7	16	2.5	3.02	745
HSDLB-40-6	40	6	48	3.5	7	16	2.5	3.02	1185

*1 US Ton = 2,000 lbs.



HSDLB STANDARD DUTY LIFTING BEAM I-BEAM DESIGN w/FLAME CUT BAIL

FEATURES

- This style of lifting beam can be utilized where headroom is limited and comes with a pair of shackles & swivel hooks with three standard spreads.
- Standard I-Beam construction with integrated beam stands.
- Three standard lift points for load adjustment: outside lift point, middle lift point (outside less 1'), inside lift point (middle less 1').
- Engineered and manufactured to ASME B30.20 & BTH-1 Design Category B Service Class 2.
- 100% of ALL lifting beams are Proof Tested to 125% capacity and certificates supplied at No Additional Charge.
- Made in USA.

OPTIONS

- Additional lift points
- Higher capacities
- Additional lengths
- Low headroom bail
- Additional hooks & shackles.

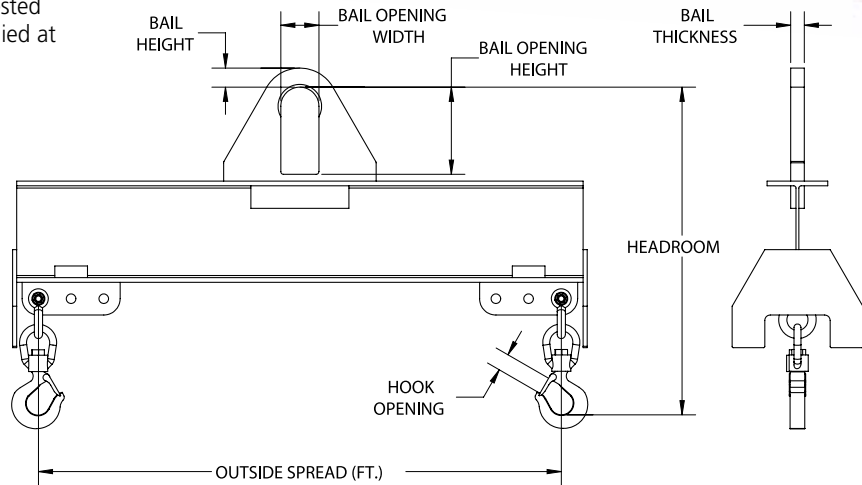
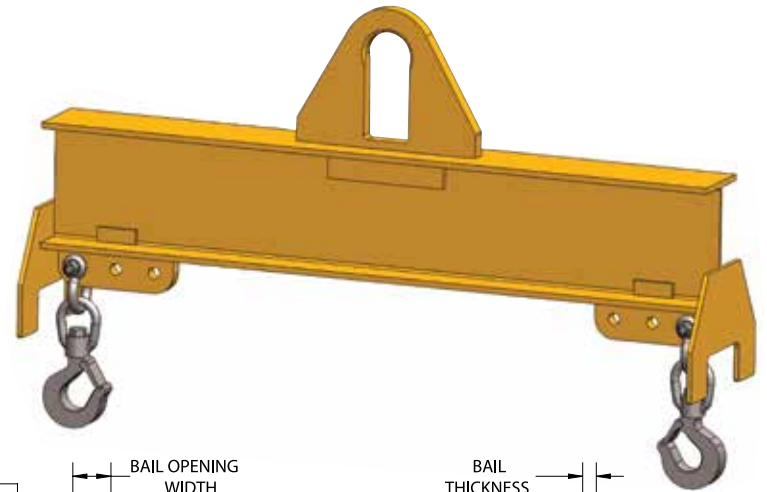

Model #	Capacity (US Tons)*	Outside Spread (Ft.)	Dimensions (Inches)						Weight (Lbs.)
			Headroom	Bail Height	Bail Opening Width	Bail Opening Height	Bail Thickness	Hook Opening	
HSDLB-1-30	1	30	26	0.88	3	5	0.75	0.89	1575
HSDLB-1-34	1	34	24	0.88	3	5	0.75	0.89	1685
HSDLB-1-38	1	38	24	0.88	3	5	0.75	0.89	2225
HSDLB-1-42	1	42	26	0.88	3	5	0.75	0.89	2950
HSDLB-2-30	2	30	26	0.88	3	5	0.75	0.89	1680
HSDLB-2-34	2	34	24	1.50	3	5	1	0.89	2240
HSDLB-2-38	2	38	25	1.50	3	5	1	0.89	2820
HSDLB-2-42	2	42	27	1.50	3	5	1	0.89	3580
HSDLB-3-30	3	30	28	1.25	3	5	1	1	1995
HSDLB-3-34	3	34	27	1.5	3	5	1	1	2175
HSDLB-3-38	3	38	28	1.5	3	5	1	1	3270
HSDLB-3-42	3	42	29	1.5	3	5	1	1	4085
HSDLB-5-30	5	30	30	2	4	7	1.25	1.36	2430
HSDLB-5-34	5	34	32	2	4	7	1.25	1.36	3290
HSDLB-5-38	5	38	34	2	4	7	1.25	1.36	4150
HSDLB-5-42	5	42	34	2	4	7	1.25	1.36	5000
HSDLB-7.5-20	7.5	20	33	2	4	7	1.25	1.61	1390
HSDLB-7.5-24	7.5	24	33	2	4	7	1.25	1.61	1985
HSDLB-7.5-30	7.5	30	33	2	4	7	1.25	1.61	2900
HSDLB-7.5-34	7.5	34	37	2	4	7	1.25	1.61	3740
HSDLB-7.5-38	7.5	38	37	2	4	7	1.25	1.61	5000
HSDLB-7.5-42	7.5	42	37	2	4	7	1.25	1.61	6020

*1 US Ton = 2,000 lbs.

cont.



DO NOT EXCEED CAPACITY!
See the SAFETY GUIDELINES section before using these products. Pages 92-94.

HSDLB

STANDARD DUTY LIFTING BEAM

I-BEAM DESIGN w/FLAME CUT BAIL cont.

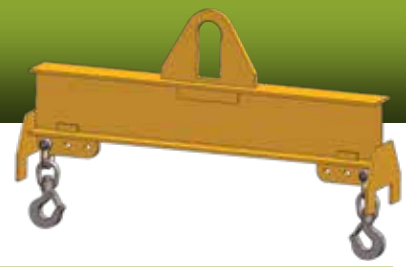

Model #	Capacity (US Tons)*	Outside Spread (Ft.)	Dimensions (Inches)						Weight (Lbs.)
			Headroom	Bail Height	Bail Opening Width	Bail Opening Height	Bail Thickness	Hook Opening	
HSDLB-10-20	10	20	34	2	4	7	1.25	1.61	1540
HSDLB-10-24	10	24	34	2	4	7	1.25	1.61	2180
HSDLB-10-30	10	30	36	2	4	7	1.25	1.61	3310
HSDLB-10-34	10	34	38	2	4	7	1.25	1.61	4515
HSDLB-10-38	10	38	38	2	4	7	1.25	1.61	5495
HSDLB-10-42	10	42	39	2	4	7	1.25	1.61	7260
HSDLB-15-16	15	16	39	2.5	5	9	1.5	2.08	1430
HSDLB-15-18	15	18	40	2.5	5	9	1.5	2.08	1690
HSDLB-15-20	15	20	40	2.5	5	9	1.5	2.08	2015
HSDLB-15-24	15	24	41	2.5	5	9	1.5	2.08	2825
HSDLB-15-30	15	30	40	2.5	5	9	1.5	2.08	4470
HSDLB-15-34	15	34	42	2.5	5	9	1.5	2.08	5400
HSDLB-15-38	15	38	43	2.5	5	9	1.5	2.08	6655
HSDLB-15-42	15	42	43	2.5	5	9	1.5	2.08	8840
HSDLB-20-14	20	14	43	2.5	5	9	1.5	2.27	1270
HSDLB-20-16	20	16	44	2.5	5	9	1.5	2.27	1590
HSDLB-20-18	20	18	44	2.5	5	9	1.5	2.27	1980
HSDLB-20-20	20	20	46	2.5	5	9	1.5	2.27	2340
HSDLB-20-24	20	24	46	2.5	5	9	1.5	2.27	3315
HSDLB-20-30	20	30	47	2.5	5	9	1.5	2.27	5295
HSDLB-20-34	20	34	49	2.75	5	9	1.5	2.27	6565
HSDLB-20-38	20	38	55	2.75	5	9	1.5	2.27	8580
HSDLB-20-42	20	42	56	2.75	5	9	1.5	2.27	10430
HSDLB-25-14	25	14	52	3	6	12	1.75	2.27	1620
HSDLB-25-16	25	16	52	3	6	12	1.75	2.27	1995
HSDLB-25-18	25	18	54	3	6	12	1.75	2.27	2345
HSDLB-25-20	25	20	57	3	6	12	1.75	2.27	2865
HSDLB-25-24	25	24	57	3	6	12	1.75	2.27	3870
HSDLB-25-30	25	30	58	3	6	12	1.75	2.27	5810
HSDLB-25-34	25	34	64	3	6	12	1.75	2.27	7800
HSDLB-25-38	25	38	65	3	6	12	1.75	2.27	9555
HSDLB-25-42	25	42	67	3	6	12	1.75	2.27	11800
HSDLB-30-10	30	10	52	3.5	7	16	2	2.27	1210
HSDLB-30-12	30	12	54	3.5	7	16	2	2.27	1465
HSDLB-30-14	30	14	54	3.5	7	16	2	2.27	1780
HSDLB-30-16	30	16	54	3.5	7	16	2	2.27	2155
HSDLB-30-18	30	18	59	3.5	7	16	2	2.27	2500
HSDLB-30-20	30	20	59	3.5	7	16	2	2.27	2995
HSDLB-30-24	30	24	60	3.5	7	16	2	2.27	4240
HSDLB-30-30	30	30	65	3.5	7	16	2	2.27	6015
HSDLB-30-34	30	34	72	3.5	7	16	2	2.27	8330
HSDLB-30-38	30	38	70	3.5	7	16	2	2.27	10605
HSDLB-30-42	30	42	70	3.5	7	16	2	2.27	12915
HSDLB-40-8	40	8	62	3.5	7	16	2.5	3.02	1260
HSDLB-40-10	40	10	63	3.5	7	16	2.5	3.02	1630
HSDLB-40-12	40	12	63	3.5	7	16	2.5	3.02	1935
HSDLB-40-14	40	14	63	3.5	7	16	2.5	3.02	2335
HSDLB-40-16	40	16	65	3.5	7	16	2.5	3.02	2520
HSDLB-40-18	40	18	66	3.5	7	16	2.5	3.02	3255
HSDLB-40-20	40	20	68	3.5	7	16	2.5	3.02	3865
HSDLB-40-24	40	24	71	3.5	7	16	2.5	3.02	5170
HSDLB-40-30	40	30	75	3.5	7	16	2.5	3.02	7155
HSDLB-40-34	40	34	77	3.5	7	16	2.5	3.02	9780
HSDLB-40-38	40	38	80	3.5	7	16	2.5	3.02	12075
HSDLB-40-42	40	42	83	3.5	7	16	2.5	3.02	15240

*1 US Ton = 2,000 lbs.



HSDLB STANDARD DUTY LIFTING BEAM I-BEAM DESIGN w/PIN BAIL

FEATURES

- This style of lifting beam can be utilized where headroom is limited & comes with a pair of shackles and three standard spreads.
- Standard I-Beam construction with pin bail & integrated beam stands.
- Three standard lift points for load adjustment: outside lift point, middle lift point (outside less 1'), inside lift point (middle less 1').
- Engineered & manufactured to ASME B30.20 & BTH-1 Design Category B Service Class 2.
- 100% of ALL lifting beams are Proof-Tested to 125% capacity & certificates supplied at No Additional Charge.
- Made in USA.

OPTIONS

- Additional lift points
- Higher capacities
- Additional lengths
- Swivel hooks
- Additional shackles

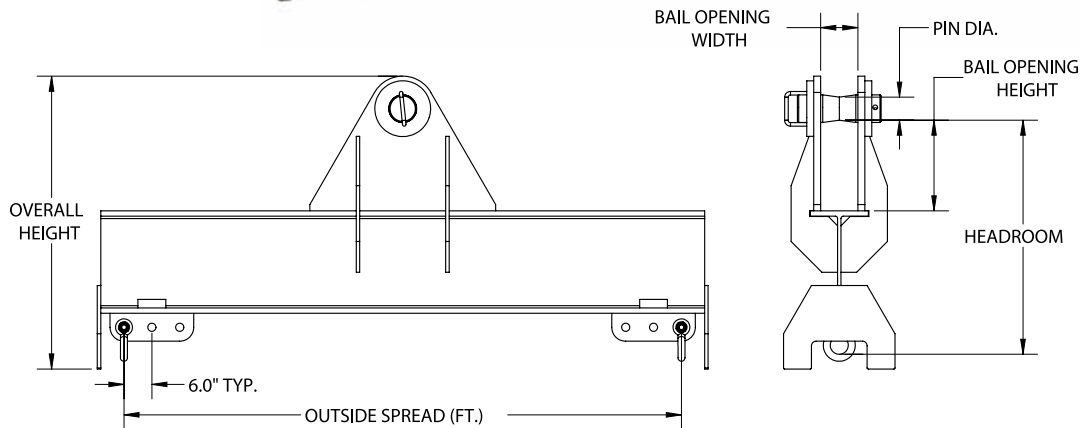
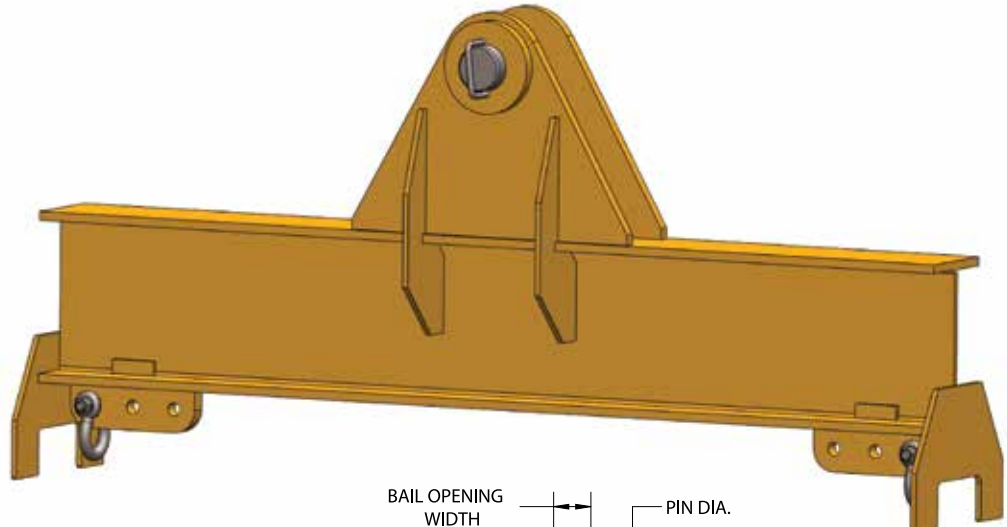

Model #	Capacity (US Tons)*	Outside Spread (Ft.)	Dimensions (Inches)					Overall Width	Overall Height	Weight (Lbs.)
			Headroom	Pin Diameter	Bail Opening Width	Bail Opening Height				
HSDLB-50-10	50	10	57	5	8	19.5	138	70	3313	
HSDLB-50-15	50	15	58	5	8	19.5	198	71	4417	
HSDLB-50-20	50	20	58	5	8	19.5	258	71	5935	
HSDLB-65-10	65	10	58	5	8	19.5	138	71	3518	
HSDLB-65-15	65	15	61	5	8	19.5	198	74	4735	
HSDLB-65-20	65	20	64	5	8	19.5	258	77	6671	
HSDLB-80-10	80	10	64	5.5	8	21.25	138	77	4212	
HSDLB-80-15	80	15	67	5.5	8	21.25	198	80	5529	
HSDLB-80-20	80	20	70	5.5	8	21.25	258	83	7675	

*1 US Ton = 2,000 lbs.



DO NOT EXCEED CAPACITY!
See the SAFETY GUIDELINES section before using these products. Pages 92–94.

HBSLB BASKET SLING LIFTING BEAM

FEATURES

- This style of lifting beam can be utilized where headroom is limited with slings in a basket hitch.
- Includes two sets of fixed hooks (3' and 4' beams have one set of hooks).
- Two standard lift points for load adjustment; outside lift point & inside lift point (1/2 the overall length).
- Engineered & manufactured to ASME B30.20 & BTH-1 Design Category B Service Class 2.
- 100% of ALL lifting beams are Proof-Tested to 125% capacity & certificates supplied at No Additional Charge.
- Made in USA.

OPTIONS

- Additional lift points
- Higher capacities
- Additional lengths
- Low headroom bail
- Additional hooks
- Sling spacers

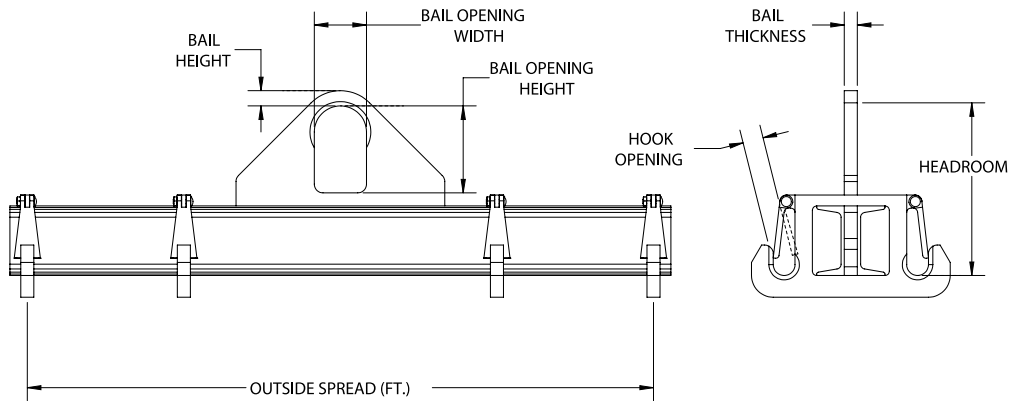
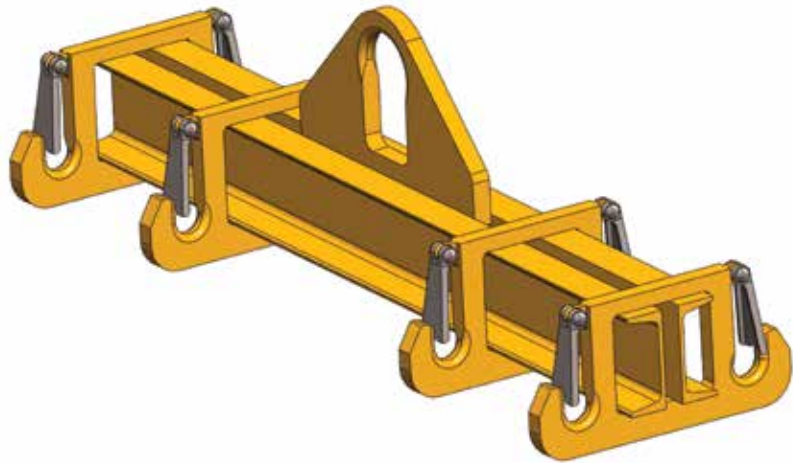

Model #	Capacity (US Tons)*	Outside Spread (Ft.)	Dimensions (Inches)						Weight (Lbs.)
			Headroom	Bail Height	Bail Opening Width	Bail Opening Height	Bail Thickness	Hook Opening	
HBSLB-1/2-3	1/2	3	9	0.88	3	5	0.75	1.06	53
HBSLB-1/2-4	1/2	4	9	0.88	3	5	0.75	1.06	68
HBSLB-1/2-6	1/2	6	9	0.88	3	5	0.75	1.06	116
HBSLB-1/2-8	1/2	8	9	0.88	3	5	0.75	1.06	158
HBSLB-1/2-10	1/2	10	10	0.88	3	5	0.75	1.06	210
HBSLB-1/2-12	1/2	12	10	0.88	3	5	0.75	1.06	231
HBSLB-1/2-14	1/2	14	11	0.88	3	5	0.75	1.06	313
HBSLB-1/2-16	1/2	16	11	0.88	3	5	0.75	1.06	348
HBSLB-1/2-18	1/2	18	12	0.88	3	5	0.75	1.06	445
HBSLB-1/2-20	1/2	20	12	0.88	3	5	0.75	1.06	486
HBSLB-1/2-24	1/2	24	13	0.88	3	5	0.75	1.06	658
HBSLB-1/2-30	1/2	30	14	0.88	3	5	0.75	1.06	898
HBSLB-1-3	1	3	9	0.88	3	5	0.75	1.13	53
HBSLB-1-4	1	4	9	0.88	3	5	0.75	1.13	68
HBSLB-1-6	1	6	10	0.88	3	5	0.75	1.13	152
HBSLB-1-8	1	8	11	0.88	3	5	0.75	1.13	221
HBSLB-1-10	1	10	11	0.88	3	5	0.75	1.13	242
HBSLB-1-12	1	12	12	0.88	3	5	0.75	1.13	305
HBSLB-1-14	1	14	12	0.88	3	5	0.75	1.13	355
HBSLB-1-16	1	16	13	0.88	3	5	0.75	1.13	410
HBSLB-1-18	1	18	14	0.88	3	5	0.75	1.13	566
HBSLB-1-20	1	20	14	0.88	3	5	0.75	1.13	617
HBSLB-1-24	1	24	16	0.88	3	5	0.75	1.13	952
HBSLB-1-30	1	30	16	0.88	3	5	0.75	1.13	1208

*1 US Ton = 2,000 lbs.

cont.



BASKET SLING LIFTING BEAM cont.

Model #	Capacity (US Tons)*	Outside Spread (Ft.)	Dimensions (Inches)						Weight (Lbs.)
			Headroom	Bail Height	Bail Opening Width	Bail Opening Height	Bail Thickness	Hook Opening	
HBSLB-2-3	2	3	10	0.88	3	5	0.75	1.13	74
HBSLB-2-4	2	4	11	0.88	3	5	0.75	1.13	95
HBSLB-2-6	2	6	11	0.88	3	5	0.75	1.13	168
HBSLB-2-8	2	8	12	0.88	3	5	0.75	1.13	236
HBSLB-2-10	2	10	13	0.88	3	5	0.75	1.13	315
HBSLB-2-12	2	12	14	0.88	3	5	0.75	1.13	394
HBSLB-2-14	2	14	14	0.88	3	5	0.75	1.13	469
HBSLB-2-16	2	16	15	0.88	3	5	0.75	1.13	541
HBSLB-2-18	2	18	16	0.88	3	5	0.75	1.13	761
HBSLB-2-20	2	20	16	0.88	3	5	0.75	1.13	856
HBSLB-2-24	2	24	18	0.88	3	5	0.75	1.13	1282
HBSLB-2-30	2	30	21	0.88	3	5	0.75	1.13	2386
HBSLB-5-3	5	3	14	2	4	7	1	1.13	95
HBSLB-5-4	5	4	15	2	4	7	1	1.13	168
HBSLB-5-6	5	6	16	2	4	7	1	1.13	289
HBSLB-5-8	5	8	17	2	4	7	1	1.13	368
HBSLB-5-10	5	10	17	2	4	7	1	1.13	473
HBSLB-5-12	5	12	17	2	4	7	1	1.13	525
HBSLB-5-14	5	14	19	2	4	7	1.25	1.13	897
HBSLB-5-16	5	16	20	2	4	7	1.25	1.13	987
HBSLB-5-18	5	18	23	2	4	7	1.25	1.13	1468
HBSLB-5-20	5	20	23	2	4	7	1.25	1.13	1733
HBSLB-5-24	5	24	23	2	4	7	1.25	1.13	2251
HBSLB-5-30	5	30	26	2	4	7	1.25	1.13	2447
HBSLB-7.5-3	7.5	3	15	2	4	7	1.25	1.75	158
HBSLB-7.5-4	7.5	4	16	2	4	7	1.25	1.75	189
HBSLB-7.5-6	7.5	6	17	2	4	7	1.25	1.75	336
HBSLB-7.5-8	7.5	8	18	2	4	7	1.25	1.75	431
HBSLB-7.5-10	7.5	10	18	2	4	7	1.25	1.75	525
HBSLB-7.5-12	7.5	12	20	2	4	7	1.25	1.75	735
HBSLB-7.5-14	7.5	14	23	2	4	7	1.25	1.75	1204
HBSLB-7.5-16	7.5	16	23	2	4	7	1.25	1.75	1364
HBSLB-7.5-18	7.5	18	23	2	4	7	1.25	1.75	1541
HBSLB-7.5-20	7.5	20	23	2	4	7	1.25	1.75	1686
HBSLB-7.5-24	7.5	24	26	2	4	7	1.25	1.75	2452
HBSLB-7.5-30	7.5	30	26	2	4	7	1.25	1.75	3021
HBSLB-10-3	10	3	16	2	4	7	1.25	1.75	163
HBSLB-10-4	10	4	17	2	4	7	1.25	1.75	210
HBSLB-10-6	10	6	18	2	4	7	1.25	1.75	347
HBSLB-10-8	10	8	20	2	4	7	1.25	1.75	525
HBSLB-10-10	10	10	23	2	4	7	1.25	1.75	893
HBSLB-10-12	10	12	20	2	4	7	1.25	1.75	1050
HBSLB-10-14	10	14	23	2	4	7	1.25	1.75	1220
HBSLB-10-16	10	16	23	2	4	7	1.25	1.75	1365
HBSLB-10-18	10	18	26	2	4	7	1.25	1.75	1827
HBSLB-10-20	10	20	26	2	4	7	1.25	1.75	2040
HBSLB-10-24	10	24	26	2	4	7	1.25	1.75	2472
HBSLB-10-30	10	30	26	2	4	7	1.25	1.75	3110

*1 US Ton = 2,000 lbs.

cont.



DO NOT EXCEED CAPACITY!
See the SAFETY GUIDELINES section before using these products. Pages 92–94.

HBSLB BASKET SLING LIFTING BEAM cont.

FEATURES

- This style of lifting beam can be utilized where headroom is limited with slings in a basket hitch.
- Includes two sets of fixed hooks (3' and 4' beams have one set of hooks).
- Two standard lift points for load adjustment; outside lift point & inside lift point (1/2 the overall length).
- Engineered & manufactured to ASME B30.20 & BTH-1 Design Category B Service Class 2.
- 100% of ALL lifting beams are Proof-Tested to 125% capacity & certificates supplied at No Additional Charge.
- Made in USA.

OPTIONS

- Additional lift points
- Higher capacities
- Additional lengths
- Low headroom bail
- Additional hooks
- Sling spacers

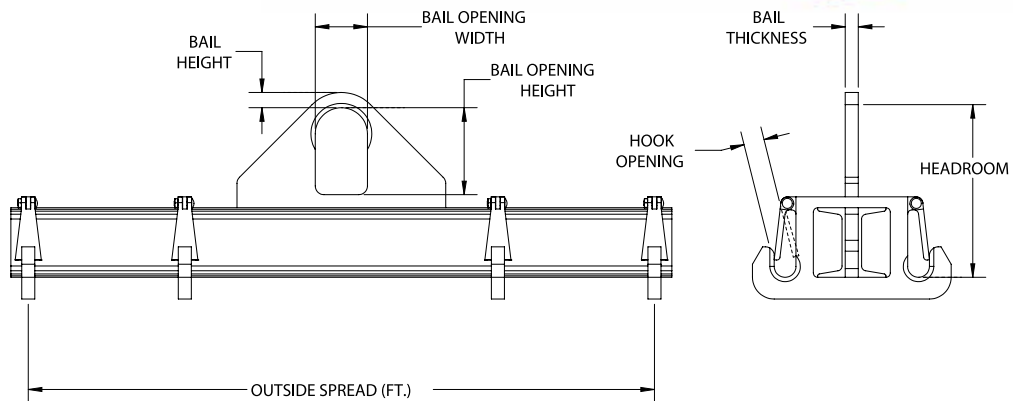
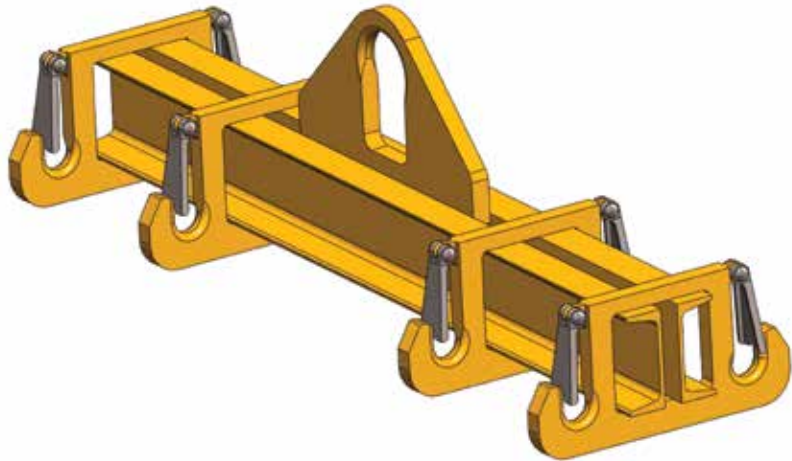

Model #	Capacity (US Tons)*	Outside Spread (Ft.)	Dimensions (Inches)						Weight (Lbs.)
			Headroom	Bail Height	Bail Opening Width	Bail Opening Height	Bail Thickness	Hook Opening	
HBSLB-15-3	15	3	19	2.5	5	9	1.5	4	266
HBSLB-15-4	15	4	20	2.5	5	9	1.5	4	344
HBSLB-15-6	15	6	22	2.5	5	9	1.5	4	956
HBSLB-15-8	15	8	22	2.5	5	9	1.5	4	1050
HBSLB-15-10	15	10	25	2.5	5	9	1.5	4	1208
HBSLB-15-12	15	12	28	2.5	5	9	1.5	4	1827
HBSLB-15-14	15	14	28	2.5	5	9	1.5	4	2032
HBSLB-15-16	15	16	28	2.5	5	9	1.5	4	2205
HBSLB-15-18	15	18	28	2.5	5	9	1.5	4	2511
HBSLB-15-20	15	20	28	2.5	5	9	1.5	4	2713
HBSLB-15-24	15	24	28	2.5	5	9	1.5	4	3675
HBSLB-15-30	15	30	30	2.5	5	9	1.5	4	4305
HBSLB-20-3	20	3	20	2.5	5	9	1.5	4	417
HBSLB-20-4	20	4	22	2.5	5	9	1.5	4	495
HBSLB-20-6	20	6	22	2.5	5	9	1.5	4	1019
HBSLB-20-8	20	8	25	2.5	5	9	1.5	4	1302
HBSLB-20-10	20	10	25	2.5	5	9	1.5	4	1319
HBSLB-20-12	20	12	25	2.5	5	9	1.5	4	2079
HBSLB-20-14	20	14	28	2.5	5	9	1.5	4	2168
HBSLB-20-16	20	16	28	2.5	5	9	1.5	4	2321
HBSLB-20-18	20	18	28	2.5	5	9	1.5	4	2604
HBSLB-20-20	20	20	28	2.5	5	9	1.5	4	2893
HBSLB-20-24	20	24	31	2.5	5	9	1.5	4	4247
HBSLB-20-30	20	30	31	2.5	5	9	1.5	4	4725

*1 US Ton = 2,000 lbs.



HDCLB DUAL CRANE LIFTING BEAM

FEATURES

- This style of lifting beam is utilized with two cranes, where headroom is limited, and comes standard with a swivel hook.
- Roller bearing hook standard on capacities 30 tons and over.
- Engineered and manufactured to ASME B30.20 & BTH-1 Design Category B Service Class 2.
- 100% of ALL lifting beams are Proof-Tested to 125% capacity and certificates supplied at No Additional Charge.
- Made in USA.

OPTIONS

- Additional lift points
- Higher capacities
- Additional lengths
- Center bail
- Additional hooks
- Integrated beam stands

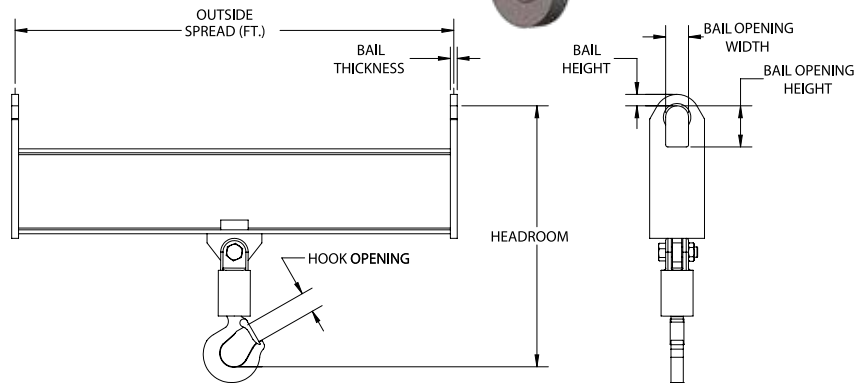
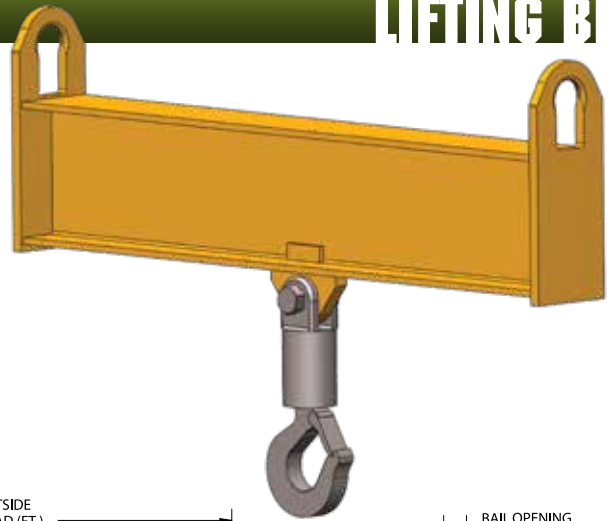

Model #	Capacity (US Tons)*	Outside Spread (Ft.)	Dimensions (Inches)						Weight (Lbs.)
			Headroom	Bail Height	Bail Opening Width	Bail Opening Height	Bail Thickness	Hook Opening	
HDCLB-2-6	2	6	17	1.5	3	5	0.63	1.09	125
HDCLB-2-8	2	8	17	1.5	3	5	0.63	1.09	160
HDCLB-2-10	2	10	18	1.5	3	5	0.63	1.09	240
HDCLB-2-12	2	12	18	1.5	3	5	0.63	1.09	280
HDCLB-2-14	2	14	19	1.5	3	5	0.63	1.09	360
HDCLB-2-16	2	16	19	1.5	3	5	0.63	1.09	400
HDCLB-2-18	2	18	19	1.5	3	5	0.63	1.09	530
HDCLB-2-20	2	20	19	1.5	3	5	0.63	1.09	660
HDCLB-2-24	2	24	20	1.5	3	5	0.63	1.09	790
HDCLB-4-6	4	6	20	1.5	3	5	0.63	1.61	160
HDCLB-4-8	4	8	21	1.5	3	5	0.63	1.61	240
HDCLB-4-10	4	10	22	1.5	3	5	0.63	1.61	310
HDCLB-4-12	4	12	23	1.5	3	5	0.63	1.61	410
HDCLB-4-14	4	14	23	1.5	3	5	0.63	1.61	500
HDCLB-4-16	4	16	25	1.5	3	5	0.63	1.61	725
HDCLB-4-18	4	18	25	1.5	3	5	0.63	1.61	805
HDCLB-4-20	4	20	25	1.5	3	5	0.63	1.61	890
HDCLB-4-24	4	24	26	1.5	3	5	0.63	1.61	1695
HDCLB-6-6	6	6	28	1.5	3	5	0.75	2.08	220
HDCLB-6-8	6	8	29	1.5	3	5	0.75	2.08	300
HDCLB-6-10	6	10	29	1.5	3	5	0.75	2.08	380
HDCLB-6-12	6	12	31	1.5	3	5	0.75	2.08	550
HDCLB-6-14	6	14	31	1.5	3	5	0.75	2.08	640
HDCLB-6-16	6	16	31	1.5	3	5	0.75	2.08	780
HDCLB-6-18	6	18	31	1.5	3	5	0.75	2.08	1310
HDCLB-6-20	6	20	31	1.5	3	5	0.75	2.08	1450
HDCLB-6-24	6	24	32	1.5	3	5	0.75	2.08	1735

*1 US Ton = 2,000 lbs.

cont.



DO NOT EXCEED CAPACITY!
See the SAFETY GUIDELINES section before using these products. Pages 92–94.

HDCLB DUAL CRANE LIFTING BEAM cont.

FEATURES

- This style of lifting beam is utilized with two cranes, where headroom is limited, and comes standard with a swivel hook.
- Roller bearing hook standard on capacities 30 tons and over.
- Engineered and manufactured to ASME B30.20 & BTH-1 Design Category B Service Class 2.
- 100% of ALL lifting beams are Proof-Tested to 125% capacity and certificates supplied at No Additional Charge.
- Made in USA.

OPTIONS

- Additional lift points
- Higher capacities
- Additional lengths
- Center bail
- Additional hooks
- Integrated beam stands

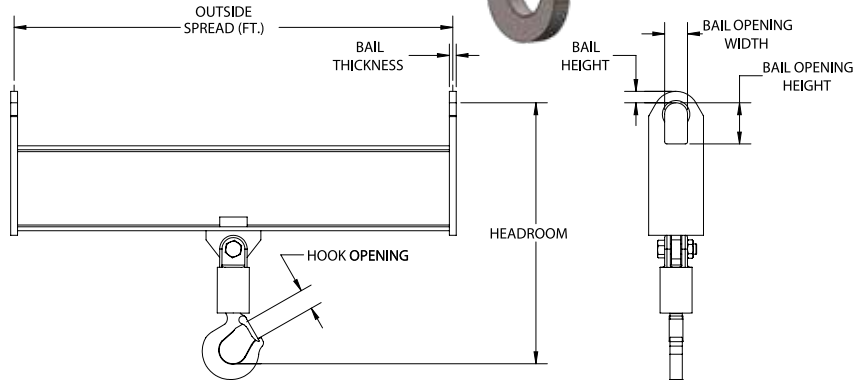
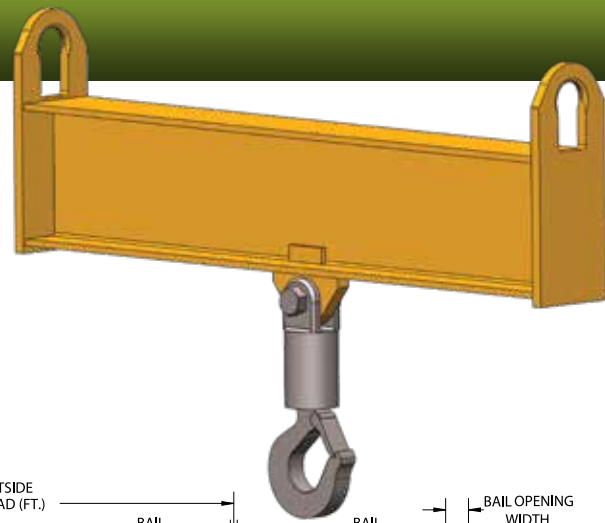

Model #	Capacity (US Tons)*	Outside Spread (Ft.)	Dimensions (Inches)						Weight (Lbs.)
			Headroom	Bail Height	Bail Opening Width	Bail Opening Height	Bail Thickness	Hook Opening	
HDCLB-10-6	10	6	29	2	4	7	1	2.27	340
HDCLB-10-8	10	8	29	2	4	7	1	2.27	420
HDCLB-10-10	10	10	32	2	4	7	1	2.27	800
HDCLB-10-12	10	12	32	2	4	7	1	2.27	920
HDCLB-10-14	10	14	32	2	4	7	1	2.27	1100
HDCLB-10-16	10	16	32	2	4	7	1	2.27	1220
HDCLB-10-18	10	18	32	2	4	7	1	2.27	1705
HDCLB-10-20	10	20	32	2	4	7	1	2.27	1840
HDCLB-10-24	10	24	33	2	4	7	1	2.27	2230
HDCLB-15-8	15	8	38	2	4	7	1.25	3.02	814
HDCLB-15-10	15	10	38	2	4	7	1.25	3.02	952
HDCLB-15-12	15	12	38	2	4	7	1.25	3.02	1155
HDCLB-15-14	15	14	41	2	4	7	1.25	3.02	2123
HDCLB-15-16	15	16	41	2	4	7	1.25	3.02	2374
HDCLB-15-18	15	18	42	2	4	7	1.25	3.02	2519
HDCLB-15-20	15	20	42	2	4	7	1.25	3.02	2750
HDCLB-15-24	15	24	42	2	4	7	1.25	3.02	2860
HDCLB-20-8	20	8	36	2	4	7	1.25	3.02	913
HDCLB-20-10	20	10	39	2	4	7	1.25	3.02	1243
HDCLB-20-12	20	12	39	2	4	7	1.25	3.02	1393
HDCLB-20-14	20	14	39	2	4	7	1.25	3.02	2119
HDCLB-20-16	20	16	39	2	4	7	1.25	3.02	2416
HDCLB-20-18	20	18	39	2	4	7	1.25	3.02	2673
HDCLB-20-20	20	20	39	2	4	7	1.25	3.02	2783
HDCLB-30-8	30	8	54	2.5	5	9	1.5	3.75	1232
HDCLB-30-10	30	10	54	2.5	5	9	1.5	3.75	1458
HDCLB-30-12	30	12	54	2.5	5	9	1.5	3.75	1771
HDCLB-40-8	40	8	59	2.5	5	9	1.5	4.25	1282
HDCLB-40-10	40	10	59	2.5	5	9	1.5	4.25	1617
HDCLB-40-12	40	12	59	2.5	5	9	1.5	4.25	1870

*1 US Ton = 2,000 lbs.





HUNVB UNIVERSAL LIFTING/SPREADER BEAM

FEATURES

- This style of universal beam can be utilized as a lifting beam where headroom is limited or a spreader beam where extra stability is required.
- As a lifting beam, the upper lift point can be easily adjusted to lift an off center load.
- Can be configured as an optional three or four point lifting system
- Can be supplied with optional chain top rigging.
- Supplied with one upper shackle for adjustable bail positions and two lower shackles for adjustable spreads.
- Engineered and manufactured to ASME B30.20 & BTH-1 Design Category B Service Class 2.
- 100% of ALL lifting beams are Proof-Tested to 125% capacity and certificates supplied at No Additional Charge.
- Made in USA.

OPTIONS

- Chain top rigging
- Three point lifting system
- Four point lifting system
- Additional lift points and spreads
- Higher capacities
- Additional lengths
- Swivel hooks

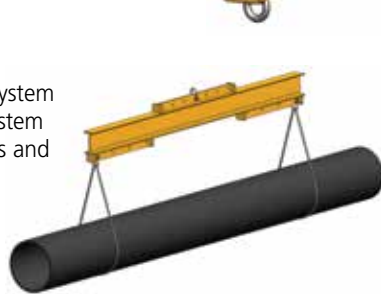
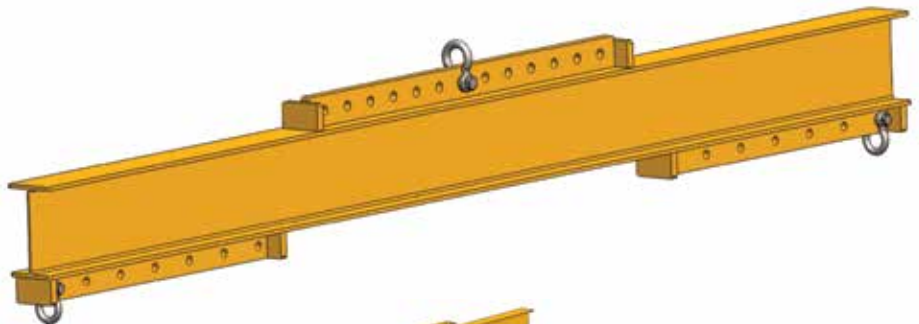
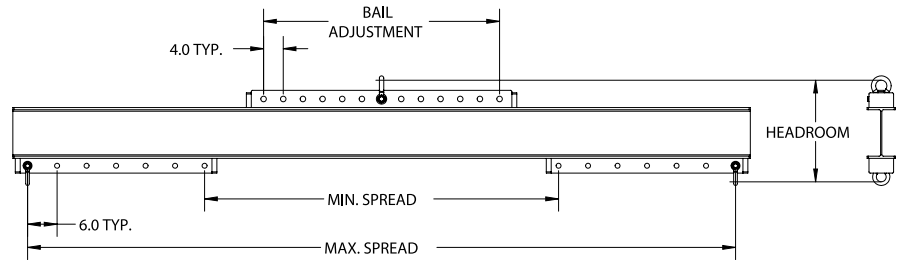

Two Point Lifting Beam



Three Point Lifting System



Four Point Lifting System

Model #	Capacity (US Tons)*	Max. Spread (Ft.)	Min. Spread (Ft.)	Dimensions (Inches)				Weight (Lbs.)
				Bail Adjustment	Headroom	Top Shackle (US Tons)*	Bottom Shackle (US Tons)*	
HUNVB-1/4-4	1/4	4	1	16	8	1.5	1.5	45
HUNVB-1/2-4	1/2	4	1	16	8	1.5	1.5	45
HUNVB-1/2-6	1/2	6	3	24	9.88	1.5	1.5	80
HUNVB-1/2-8	1/2	8	4	32	11	1.5	1.5	135
HUNVB-1/2-10	1/2	10	5	40	11	1.5	1.5	145
HUNVB-1-6	1	6	3	24	11	1.5	1.5	100
HUNVB-1-8	1	8	4	32	12	1.5	1.5	140
HUNVB-1-10	1	10	5	40	12	1.5	1.5	175
HUNVB-2-6	2	6	3	24	14	3.25	2	130
HUNVB-2-8	2	8	4	32	15	3.25	2	200
HUNVB-2-10	2	10	5	40	16	3.25	2	280
HUNVB-4-8	4	8	4	32	18	4.75	4.75	290
HUNVB-4-10	4	10	5	40	20	4.75	4.75	420
HUNVB-4-12	4	12	6	48	20	4.75	4.75	500
HUNVB-5-8	5	8	4	32	20	6.5	4.75	320
HUNVB-5-10	5	10	5	40	21	6.5	4.75	465
HUNVB-5-12	5	12	6	48	21	6.5	4.75	550
HUNVB-7-12	7	12	6	48	25	6.5	6.5	790

*1 US Ton = 2,000 lbs.



DO NOT EXCEED CAPACITY!
See the SAFETY GUIDELINES section before using these products. Pages 92–94.

HALB ADJUSTABLE LIFTING BEAM

FEATURES

- This style of lifting beam can lift off center loads easily by adjusting the bail prior to the lift.
- This lifter can be used where headroom is limited, & comes with multiple spreads that are adjustable to accommodate various load sizes at 6" adjustable increments.
- Supplied with two lower shackles.
- Engineered and manufactured to ASME B30.20 & BTH-1 Design Category B Service Class 2.
- 100% of ALL lifting beams are Proof-Tested to 125% capacity and certificates supplied at No Additional Charge.
- Made in USA.

OPTIONS

- Swivel hooks

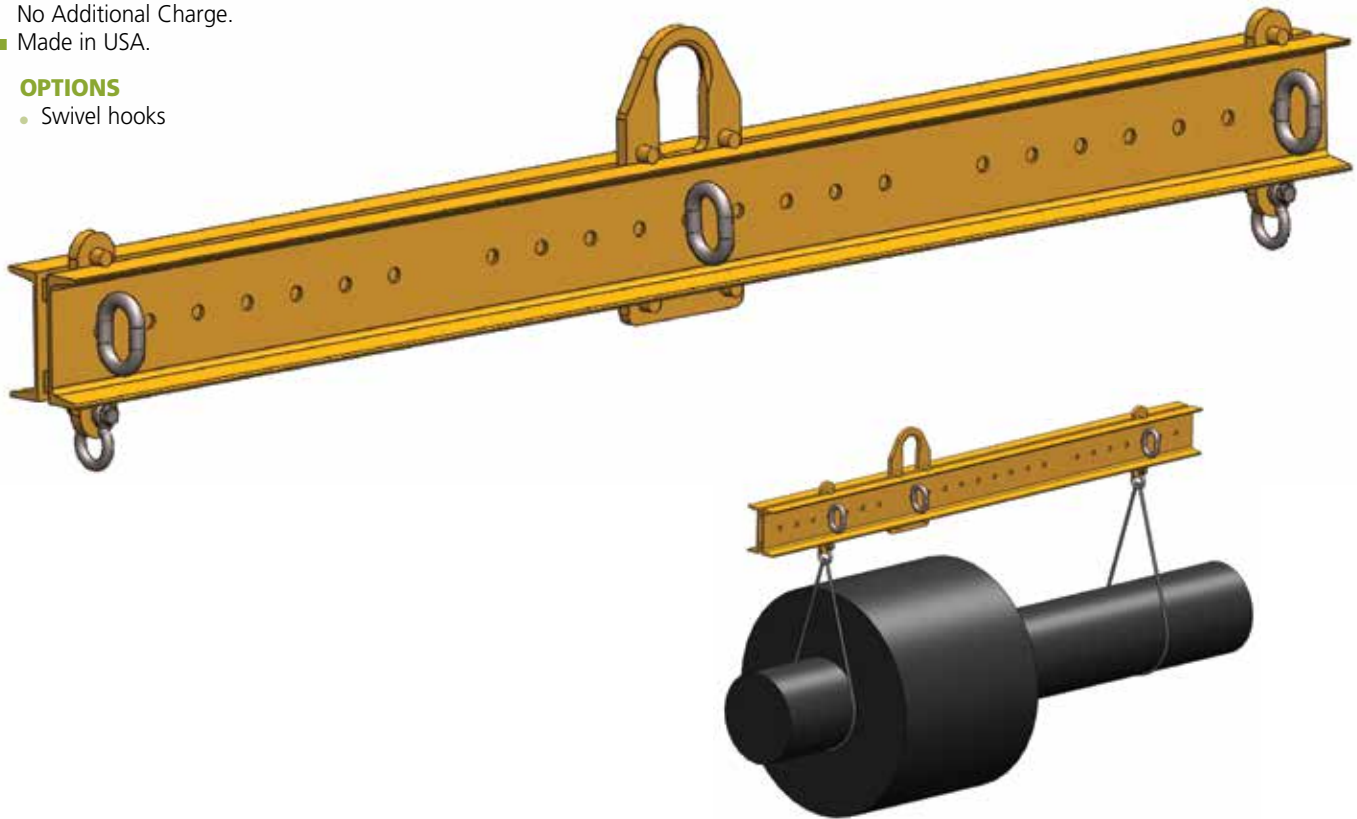
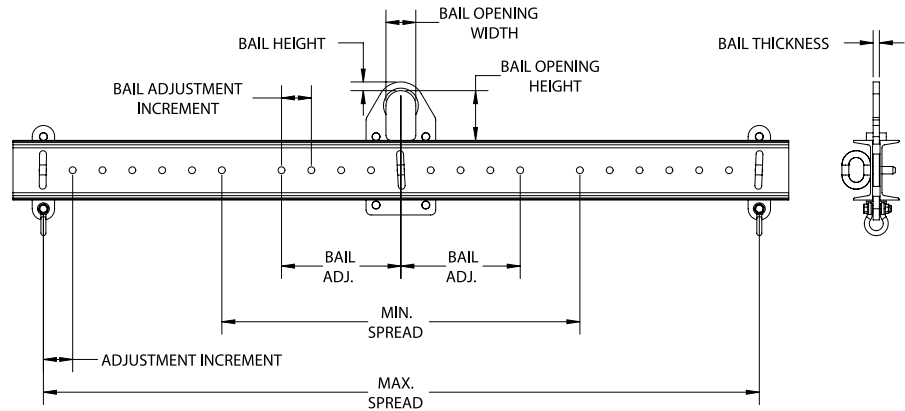

Model #	Capacity (US Tons)*	Max. Spread (Ft.)	Min. Spread (Ft.)	Dimensions (Inches)								Weight (Lbs.)
				Head-room	Bail Height	Bail Opening Width	Bail Opening Height	Bail Thickness	Bail Adjustment Increments	Bail Travel (Half of Center)	Shackle Size (US Tons)*	
HALB-1.25-6	1.25	6	3	13.5	1	3	5	0.63	3	12	2	120
HALB-2-6	2	6	3	14.5	1	3	5	0.63	3	12	2	140
HALB-4-8	4	8	4.5	20	1.5	4	7	0.75	6	18	3.25	315
HALB-5-10	5	10	5	22	1.5	4	7	1.00	6	18	4.75	440

*1 US Ton = 2,000 lbs.

HABLB ADJUSTABLE BAIL LIFTING BEAM

FEATURES

- This style of lifting beam can lift off center loads easily by adjusting the bail prior to the lift.
- This lifter can be used where headroom is limited, & comes standard with one outside spread and two swivel hooks (additional spreads & swivel hooks are available).
- Engineered & manufactured to ASME B30.20 & BTH-1 Design Category B Service Class 2.
- 100% of ALL lifting beams are Proof-Tested to 125% capacity & certificates supplied at No Additional Charge.
- Made in USA.

OPTIONS

- Additional lift points
- Higher capacities
- Additional lengths
- Low headroom bail
- Additional hooks
- Faspins
- Integrated beam stands

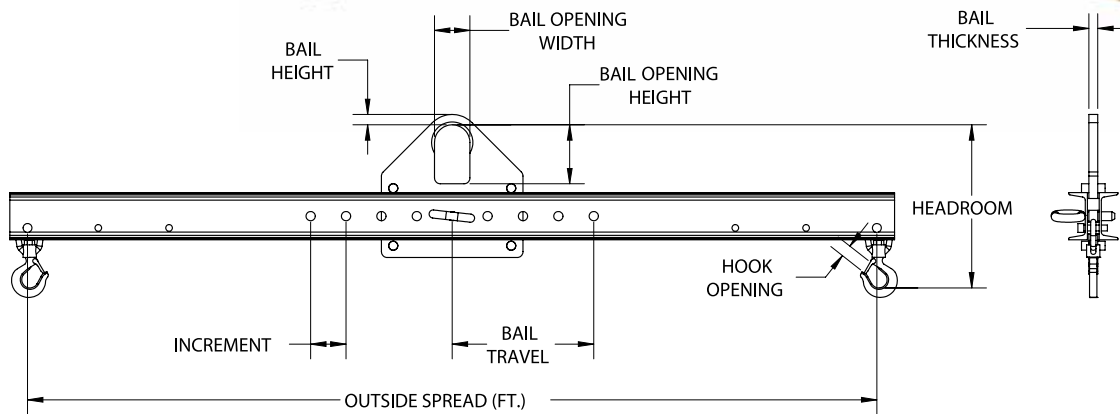
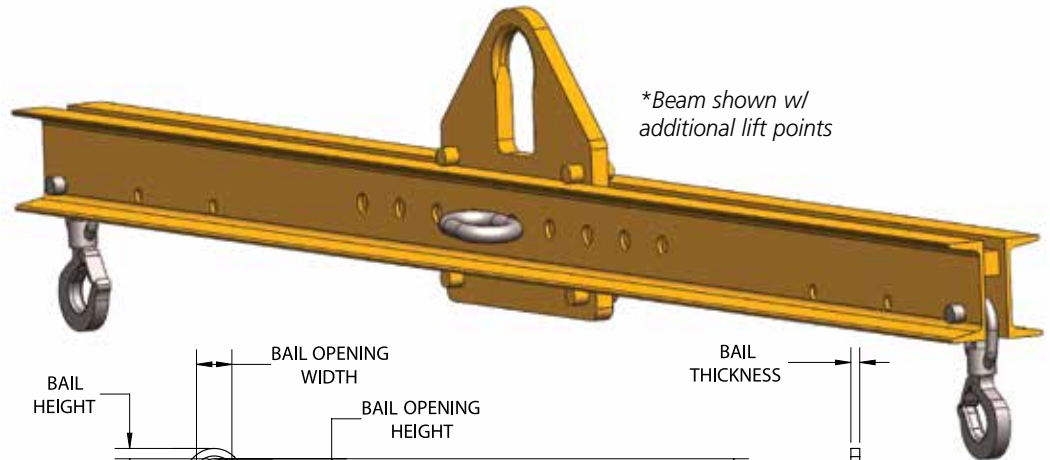

Model #	Capacity (US Tons)*	Outside Spread (Ft.)	Dimensions (Inches)								Weight (Lbs.)
			Head-room	Bail Height	Bail Opening Width	Bail Opening Height	Bail Thickness	Hook Opening	Bail Adjustment Increments	Bail Travel (Half of Center)	
HABLB-1/2-3	1/2	3	14	1.5	3	5	0.63	1	3	6	52
HABLB-1/2-4	1/2	4	14	1.5	3	5	0.63	1	3	9	62
HABLB-1/2-6	1/2	6	14	1.5	3	5	0.63	1	3	12	83
HABLB-1/2-8	1/2	8	14	1.5	3	5	0.63	1	4	16	90
HABLB-1/2-10	1/2	10	14	1.5	3	5	0.63	1	4	20	105
HABLB-1/2-12	1/2	12	14	1.5	3	5	0.63	1	4	24	162
HABLB-1/2-14	1/2	14	14	1.5	3	5	0.63	1	6	30	185
HABLB-1/2-16	1/2	16	15	1.5	3	5	0.63	1	6	36	281
HABLB-1/2-18	1/2	18	15	1.5	3	5	0.63	1	6	42	306
HABLB-1/2-20	1/2	20	15	1.5	3	5	0.63	1	6	48	334
HABLB-1-3	1	3	14	1.5	3	5	0.63	1	3	6	52
HABLB-1-4	1	4	14	1.5	3	5	0.63	1	3	9	62
HABLB-1-6	1	6	14	1.5	3	5	0.63	1	3	12	91
HABLB-1-8	1	8	15	1.5	3	5	0.63	1	4	16	139
HABLB-1-10	1	10	15	1.5	3	5	0.63	1	4	20	187
HABLB-1-12	1	12	15	1.5	3	5	0.63	1	4	24	218
HABLB-1-14	1	14	16	1.5	3	5	0.63	1	6	30	295

*1 US Ton = 2,000 lbs.

cont.



DO NOT EXCEED CAPACITY!
See the SAFETY GUIDELINES section before using these products. Pages 92–94.

HABLB ADJUSTABLE BAIL LIFTING BEAM cont.

FEATURES

- This style of lifting beam can lift off center loads easily by adjusting the bail prior to the lift.
- This lifter can be used where headroom is limited, & comes standard with one outside spread and two swivel hooks (additional spreads & swivel hooks are available).
- Engineered & manufactured to ASME B30.20 & BTH-1 Design Category B Service Class 2.
- 100% of ALL lifting beams are Proof-Tested to 125% capacity & certificates supplied at No Additional Charge.
- Made in USA.

OPTIONS

- Additional lift points
- Higher capacities
- Additional lengths
- Low headroom bail
- Additional hooks
- Faspins
- Integrated beam stands

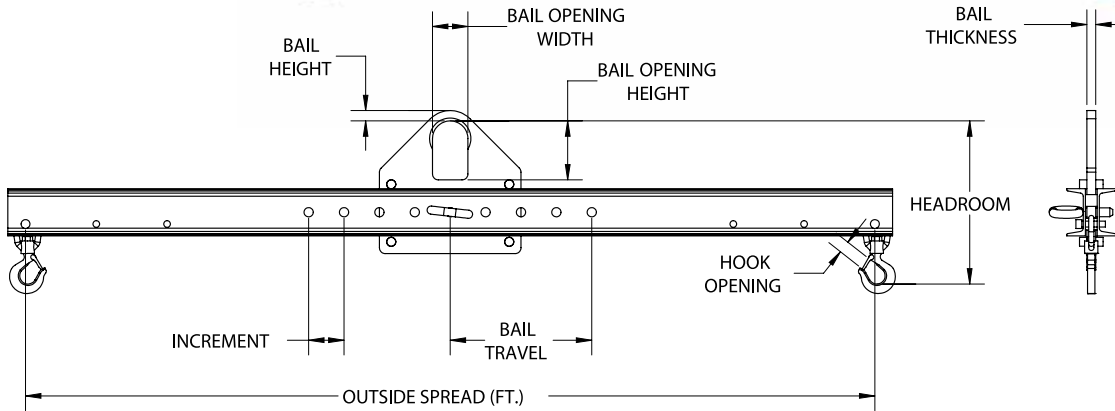
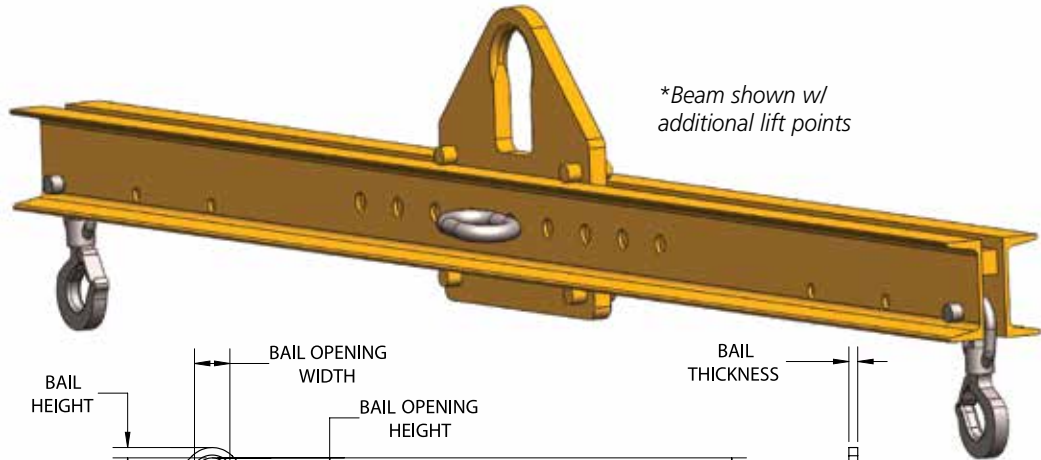

Model #	Capacity (US Tons)*	Outside Spread (Ft.)	Dimensions (Inches)								Weight (Lbs.)
			Head-room	Bail Height	Bail Opening Width	Bail Opening Height	Bail Thickness	Hook Opening	Bail Adjustment Increments	Bail Travel (Half of Center)	
HABLB-1-16	1	16	16	1.5	3	5	0.63	1	6	36	328
HABLB-1-18	1	18	17	1.5	3	5	0.63	1	6	42	450
HABLB-1-20	1	20	17	1.5	3	5	0.63	1	6	48	494
HABLB-2-3	2	3	14	1.5	3	5	0.75	1	3	6	53
HABLB-2-4	2	4	15	1.5	3	5	0.75	1	3	9	98
HABLB-2-6	2	6	15	1.5	3	5	0.75	1	3	12	129
HABLB-2-8	2	8	16	1.5	3	5	0.75	1	4	16	187
HABLB-2-10	2	10	19	1.5	3	5	0.75	1	4	20	264
HABLB-2-12	2	12	17	1.5	3	5	0.75	1	4	24	306
HABLB-2-14	2	14	18	1.5	3	5	0.75	1	6	30	406
HABLB-2-16	2	16	18	1.5	3	5	0.75	1	6	36	458
HABLB-2-18	2	18	20	1.5	3	5	0.75	1	6	42	602
HABLB-2-20	2	20	20	1.5	3	5	0.75	1	6	48	666
HABLB-5-3	5	3	22	2	4	7	1	1.36	3	6	154
HABLB-5-4	5	4	22	2	4	7	1	1.36	3	9	176
HABLB-5-6	5	6	22	2	4	7	1	1.36	3	12	237
HABLB-5-8	5	8	23	2	4	7	1	1.36	4	16	334

*1 US Ton = 2,000 lbs.

cont.



ADJUSTABLE BAIL LIFTING BEAM cont.

Model #	Capacity (US Tons)*	Outside Spread (Ft.)	Dimensions (Inches)								Weight (Lbs.)
			Head-room	Bail Height	Bail Opening Width	Bail Opening Height	Bail Thickness	Hook Opening	Bail Adjustment Increments	Bail Travel (Half of Center)	
HABLB-5-10	5	10	24	2	4	7	1	1.36	4	20	473
HABLB-5-12	5	12	27	2	4	7	1	1.36	4	24	696
HABLB-5-14	5	14	27	2	4	7	1	1.36	6	30	730
HABLB-5-16	5	16	28	2	4	7	1	1.36	6	36	821
HABLB-5-18	5	18	29	2	4	7	1	1.36	6	42	1453
HABLB-5-20	5	20	30	2	4	7	1	1.36	6	48	1678
HABLB-10-3	10	3	26	2	4	7	1.25	2.08	3	6	231
HABLB-10-4	10	4	26	2	4	7	1.25	2.08	3	9	232
HABLB-10-6	10	6	29	2	4	7	1.25	2.08	3	12	475
HABLB-10-8	10	8	29	2	4	7	1.25	2.08	4	16	574
HABLB-10-10	10	10	32	2	4	7	1.25	2.08	4	20	835
HABLB-10-12	10	12	32	2	4	7	1.25	2.08	4	24	1092
HABLB-10-14	10	14	32	2	4	7	1.25	2.08	6	30	1241
HABLB-10-16	10	16	32	2	4	7	1.25	2.08	6	36	1383
HABLB-10-18	10	18	35	2	4	7	1.25	2.08	6	42	1679
HABLB-10-20	10	20	35	2	4	7	1.25	2.08	6	48	1744
HABLB-15-3	15	3	28	2.5	5	9	1.5	2.27	3	6	277
HABLB-15-4	15	4	31	2.5	5	9	1.5	2.27	3	9	363
HABLB-15-6	15	6	34	2.5	5	9	1.5	2.27	3	12	552
HABLB-15-8	15	8	34	2.5	5	9	1.5	2.27	4	16	596
HABLB-15-10	15	10	34	2.5	5	9	1.5	2.27	4	20	970
HABLB-15-12	15	12	37	2.5	5	9	1.5	2.27	4	24	1486
HABLB-15-14	15	14	37	2.5	5	9	1.5	2.27	6	30	1540
HABLB-15-16	15	16	37	2.5	5	9	1.5	2.27	6	36	1623
HABLB-15-18	15	18	37	2.5	5	9	1.5	2.27	6	42	1912
HABLB-15-20	15	20	37	2.5	5	9	1.5	2.27	6	48	2099
HABLB-20-3	20	3	31	2.5	5	9	1.5	2.27	3	6	347
HABLB-20-4	20	4	34	2.5	5	9	1.5	2.27	3	9	439
HABLB-20-6	20	6	37	2.5	5	9	1.5	2.27	3	12	809
HABLB-20-8	20	8	37	2.5	5	9	1.5	2.27	4	16	792
HABLB-20-10	20	10	37	2.5	5	9	1.5	2.27	4	20	1404
HABLB-20-12	20	12	37	2.5	5	9	1.5	2.27	4	24	1601
HABLB-20-14	20	14	37	2.5	5	9	1.5	2.27	6	30	1793
HABLB-20-16	20	16	37	2.5	5	9	1.5	2.27	6	36	1980
HABLB-20-18	20	18	37	2.5	5	9	1.5	2.27	6	42	2063
HABLB-20-20	20	20	37	2.5	5	9	1.5	2.27	6	48	2129

*1 US Ton = 2,000 lbs.



DO NOT EXCEED CAPACITY!
See the SAFETY GUIDELINES section before using these products. Pages 92–94.

HLLB LOAD LEVELING BEAM

FEATURES

- This style of lifting beam can lift off center loads easily by adjusting the bail with the standard chain wheel prior to the lift and has unlimited adjustment within the span of the bail.
- This lifter can be used where headroom is limited, and comes standard with one outside spread and two swivel hooks (additional spreads and swivel hooks are available).
- Engineered and manufactured to ASME B30.20 & BTH-1 Design Category B Service Class 2.
- 100% of ALL lifting beams are Proof-Tested to 125% capacity and certificates supplied at No Additional Charge.
- Made in USA.

OPTIONS

- Motorized bail
- Additional lift points
- Higher capacities
- Additional lengths
- Low headroom bail
- Additional hooks
- Faspins
- Beam stand

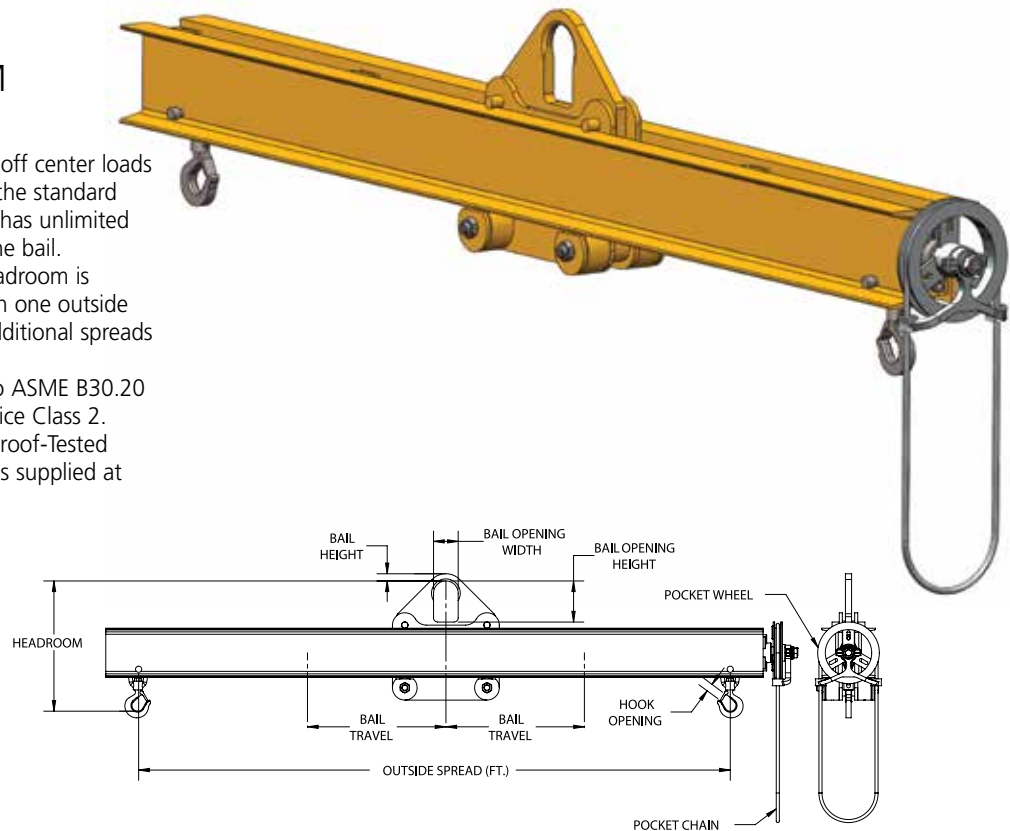

Model #	Capacity (US Tons)*	Outside Spread (Ft.)	Dimensions (Inches)							Weight (Lbs.)
			Headroom	Bail Height	Bail Opening Width	Bail Opening Height	Bail Thickness	Hook Opening	Bail Travel (Half of Center)	
HLLB-2-4	2	4	16	1.5	3	5	0.63	1	8	169
HLLB-2-6	2	6	16	1.5	3	5	0.63	1	12	231
HLLB-2-8	2	8	17	1.5	3	5	0.63	1	16	325
HLLB-2-10	2	10	18	1.5	3	5	0.63	1	20	411
HLLB-2-12	2	12	18	1.5	3	5	0.63	1	24	471
HLLB-2-14	2	14	19	1.5	3	5	0.63	1	28	601
HLLB-2-16	2	16	19	1.5	3	5	0.63	1	32	673
HLLB-2-18	2	18	20	1.5	3	5	0.63	1	36	850
HLLB-2-20	2	20	20	1.5	3	5	0.63	1	40	938
HLLB-2-24	2	24	21	1.5	3	5	0.63	1	48	1581
HLLB-5-4	5	4	23	2	4	7	1	1.36	8	213
HLLB-5-6	5	6	23	2	4	7	1	1.36	12	338
HLLB-5-8	5	8	25	2	4	7	1	1.36	16	478
HLLB-5-10	5	10	25	2	4	7	1	1.36	20	594
HLLB-5-12	5	12	27	2	4	7	1	1.36	24	851
HLLB-5-14	5	14	27	2	4	7	1	1.36	28	971
HLLB-5-16	5	16	27	2	4	7	1	1.36	32	1188
HLLB-5-18	5	18	30	2	4	7	1	1.36	36	1819
HLLB-5-20	5	20	30	2	4	7	1	1.36	40	2004
HLLB-5-24	5	24	30	2	4	7	1	1.36	48	2931
HLLB-10-4	10	4	27	2	4	7	1.25	2.08	8	321
HLLB-10-6	10	6	30	2	4	7	1.25	2.08	12	550
HLLB-10-8	10	8	30	2	4	7	1.25	2.08	16	625
HLLB-10-10	10	10	33	2	4	7	1.25	2.08	20	1175
HLLB-10-12	10	12	33	2	4	7	1.25	2.08	24	1368

*1 US Ton = 2,000 lbs.

cont.



LOAD LEVELING BEAM cont.

Model #	Capacity (US Tons)*	Outside Spread (Ft.)	Dimensions (Inches)							Weight (Lbs.)
			Headroom	Bail Height	Bail Opening Width	Bail Opening Height	Bail Thickness	Hook Opening	Bail Travel (Half of Center)	
HLLB-10-14	10	14	33	2	4	7	1.25	2.08	28	1554
HLLB-10-16	10	16	33	2	4	7	1.25	2.08	32	1735
HLLB-10-18	10	18	36	2	4	7	1.25	2.08	36	2344
HLLB-10-20	10	20	36	2	4	7	1.25	2.08	40	2406
HLLB-10-24	10	24	36	2	4	7	1.25	2.08	48	3063
HLLB-15-4	15	4	32	2.5	5	9	1.5	2.27	8	470
HLLB-15-6	15	6	35	2.5	5	9	1.5	2.27	12	706
HLLB-15-8	15	8	35	2.5	5	9	1.5	2.27	16	778
HLLB-15-10	15	10	35	2.5	5	9	1.5	2.27	20	1215
HLLB-15-12	15	12	38	2.5	5	9	1.5	2.27	24	1649
HLLB-15-14	15	14	38	2.5	5	9	1.5	2.27	28	1773
HLLB-15-16	15	16	38	2.5	5	9	1.5	2.27	32	1891
HLLB-15-18	15	18	38	2.5	5	9	1.5	2.27	36	2375
HLLB-15-20	15	20	38	2.5	5	9	1.5	2.27	40	2570
HLLB-15-24	15	24	38	2.5	5	9	1.5	2.27	48	3200
HLLB-20-4	20	4	35	2.5	5	9	1.5	2.27	8	556
HLLB-20-6	20	6	38	2.5	5	9	1.5	2.27	12	998
HLLB-20-8	20	8	38	2.5	5	9	1.5	2.27	16	1125
HLLB-20-10	20	10	38	2.5	5	9	1.5	2.27	20	1313
HLLB-20-12	20	12	38	2.5	5	9	1.5	2.27	24	2813
HLLB-20-14	20	14	38	2.5	5	9	1.5	2.27	28	2938
HLLB-20-16	20	16	38	2.5	5	9	1.5	2.27	32	3063
HLLB-20-18	20	18	38	2.5	5	9	1.5	2.27	36	3688
HLLB-20-20	20	20	38	2.5	5	9	1.5	2.27	40	3938
HLLB-20-24	20	24	38	2.5	5	9	1.5	2.27	48	4188

*1 US Ton = 2,000 lbs.



DO NOT EXCEED CAPACITY!
See the SAFETY GUIDELINES section before using these products. Pages 92–94.

HTPLB

THREE POINT LIFTING BEAM

FEATURES

- This style of lifting beam can be utilized where headroom is limited and when lifting objects that require multiple lift points.
- Designed to meet your specific lifting requirements.
- Engineered and manufactured to ASME B30.20 & BTH-1 Design Category B Service Class 2.
- 100% of ALL lifting beams are Proof-Tested to 125% capacity and certificates supplied at No Additional Charge.
- Made in USA.

OPTIONS

- Multiple lift points
- Dual bails
- Low headroom bail
- Adjustable spread
- Adjustable bail
- Swivel hooks
- Shackle lugs
- Faspins
- Beam stand

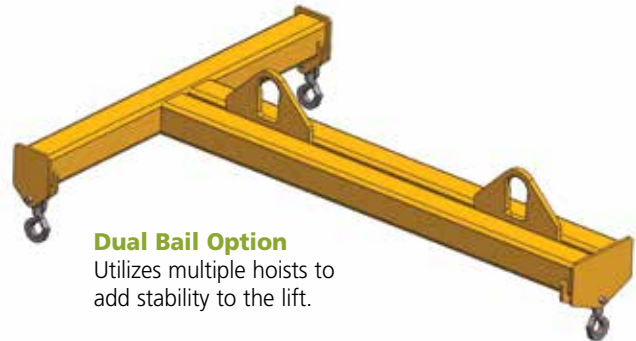

Dual Bail Option

Utilizes multiple hoists to add stability to the lift.

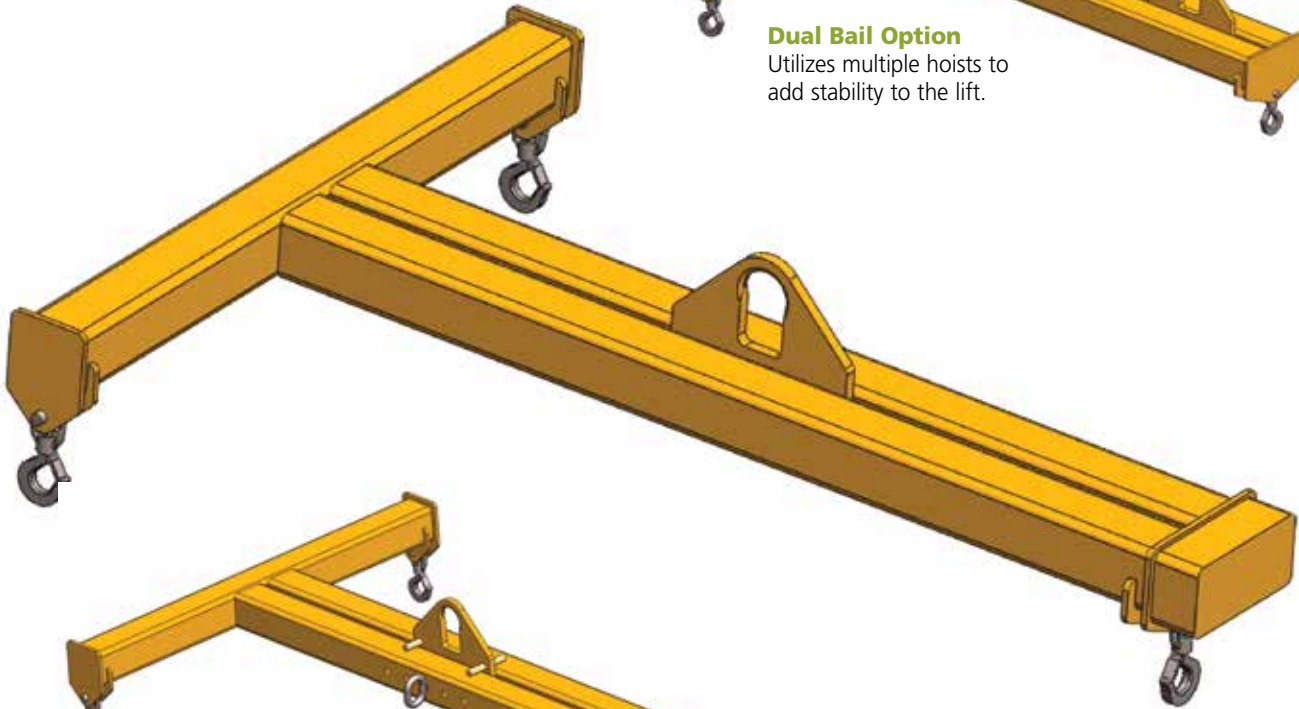

Adjustable Bail Option

Provides the option for leveling the load along the length.



Adjustable Lift Points Option

Provides the option for leveling the load along the length and width.

HFPLB FOUR POINT LIFTING BEAM

FEATURES

- This style of lifting beam can be utilized where headroom is limited and when lifting objects that require multiple lift points.
- Designed to meet your specific lifting requirements.
- Engineered and manufactured to ASME B30.20 & BTH-1 Design Category B Service Class 2.
- 100% of ALL lifting beams are Proof-Tested to 125% capacity and certificates supplied at No Additional Charge.
- Made in USA.

OPTIONS

- Multiple lift points
- Dual bails
- Low headroom bail
- Adjustable spread
- Adjustable bail
- Swivel hooks
- Drop chains
- Shackle lugs
- Faspins
- Beam stand

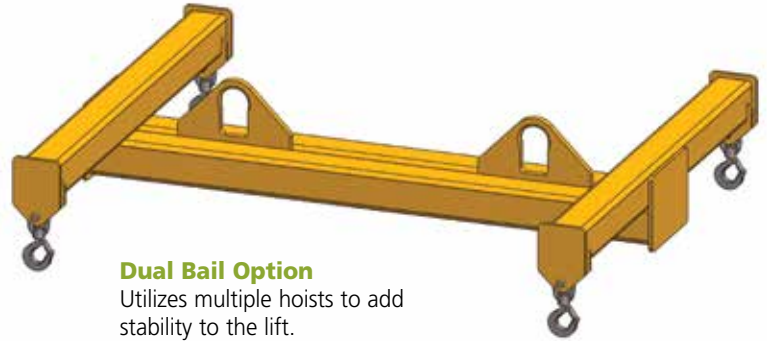

Dual Bail Option
Utilizes multiple hoists to add stability to the lift.

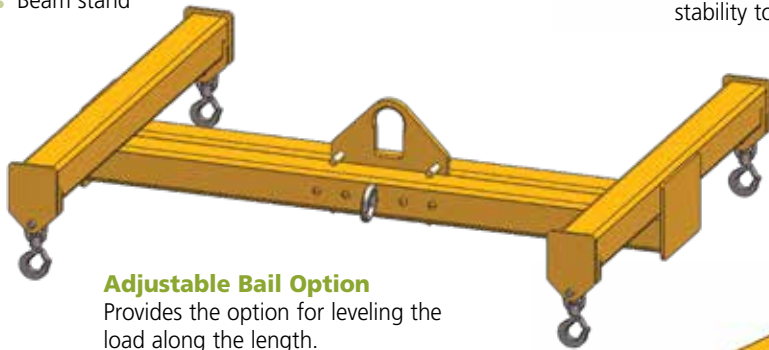

Adjustable Bail Option
Provides the option for leveling the load along the length.

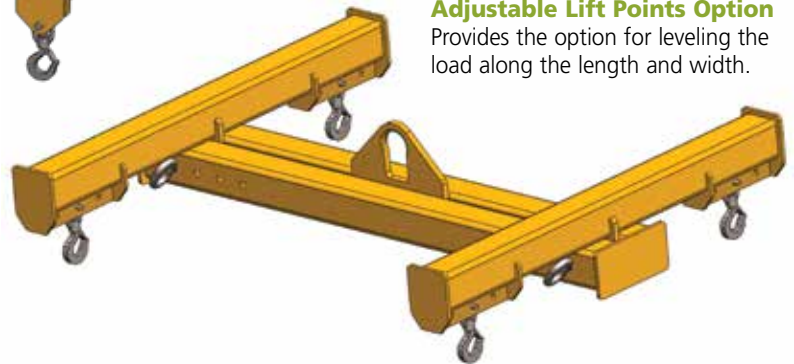

Adjustable Lift Points Option
Provides the option for leveling the load along the length and width.

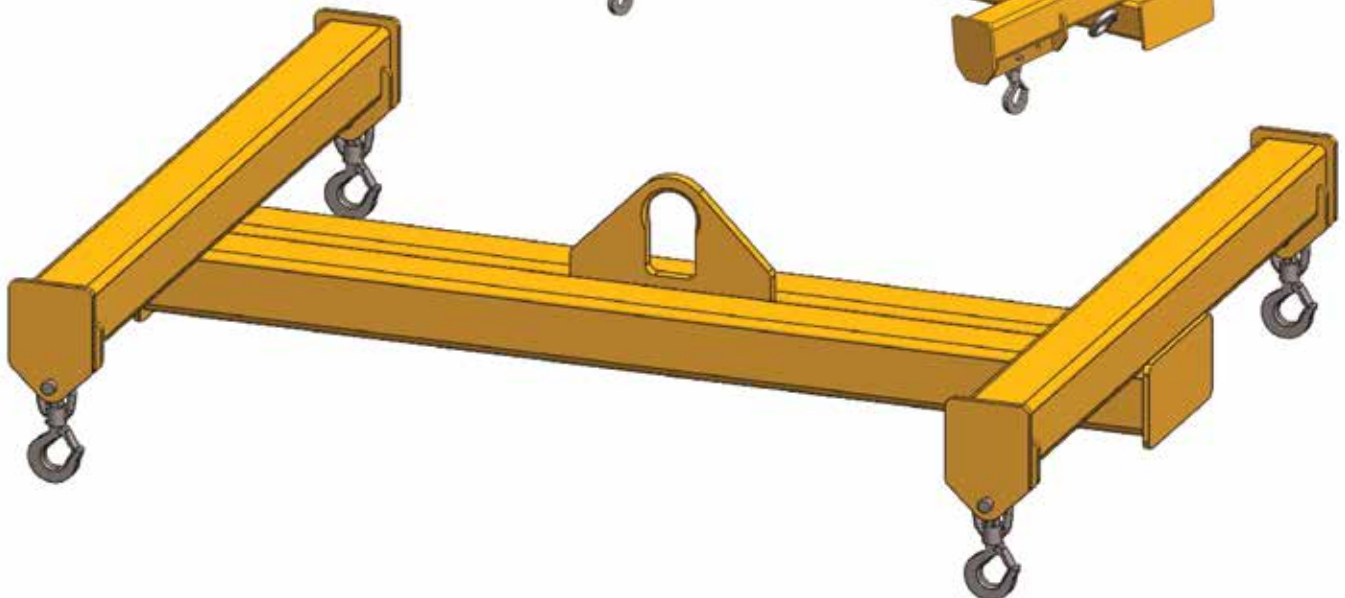

DO NOT EXCEED CAPACITY!
See the SAFETY GUIDELINES section before using these products. Pages 92–94.



HFPSL FOUR POINT SACK LIFTER BEAM

FEATURES

- This style of lifting beam is designed to lift bulk container sacks.
- Standard Sling Keeper design provides improved sling containment during the lift.
- Low headroom design that meets metric rating requirements.
- Smooth edge design to minimize wear on lifting straps.
- Engineered and manufactured to ASME B30.20 & BTH-1 Design Category B Service Class 2.
- 100% of ALL lifting beams are Proof-Tested to 125% capacity and certificates supplied at No Additional Charge.
- Made in USA.

OPTIONS

- Sling spacers
- Additional sizes are available

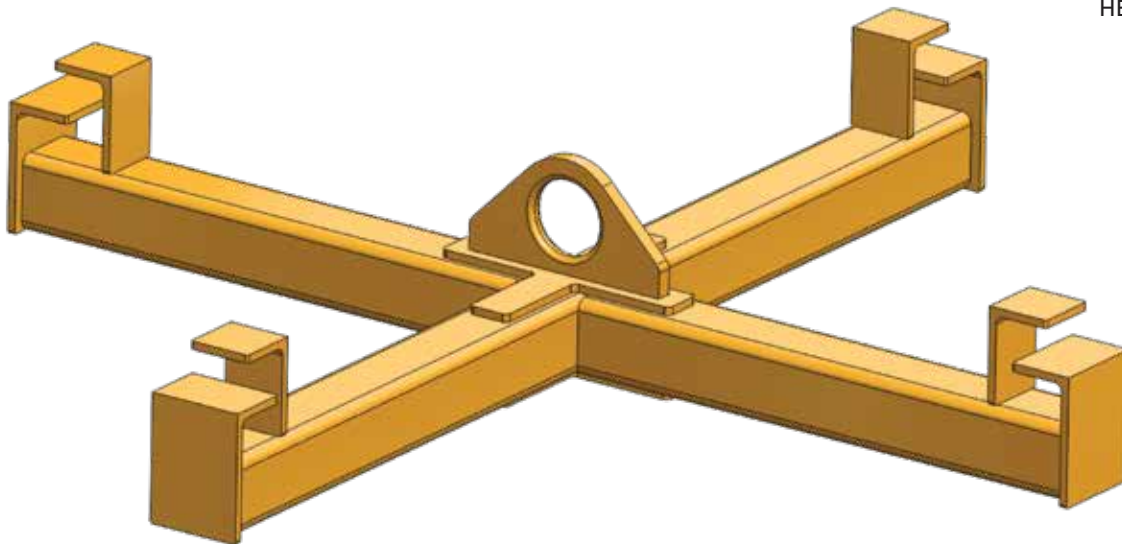
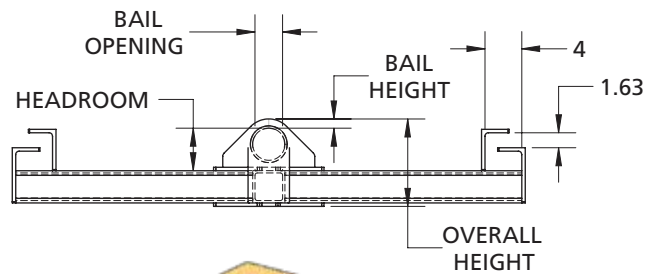
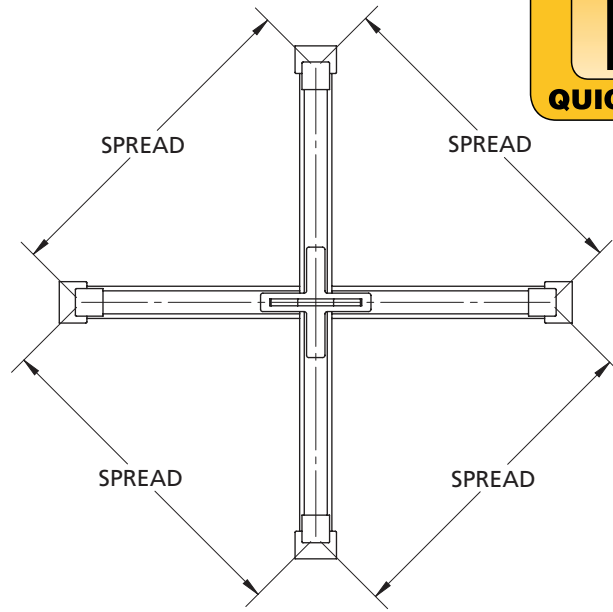

Model #	Capacity (Metric Tons)	Dimensions (Inches)					Weight (Lbs.)
		Outside Spread	Headroom	Bail Height	Bail Opening	Overall Height	
HFPSL-1-36SK	1	36	4.63	1	3.5	9	120
HFPSL-1-48SK	1	48	4.63	1	3.5	9	145
HFPSL-2-36SK	2	36	4.63	1	3.5	9.5	140
HFPSL-2-48SK	2	48	4.63	1	3.5	9.5	170



HFPAB FOUR POINT ADJUSTABLE BEAM

FEATURES

- This standard four point adjustable spread style of lifting beam can be utilized where headroom is limited and when lifting objects that require multiple lift points.
- Supplied with four swivel hooks.
- Engineered and manufactured to ASME B30.20 & BTH-1 Design Category B Service Class 2.
- 100% of ALL lifting beams are Proof-Tested to 125% capacity and certificates supplied at No Additional Charge.
- Made in USA.

OPTIONS

- Beam stand
- Additional sizes and options are available

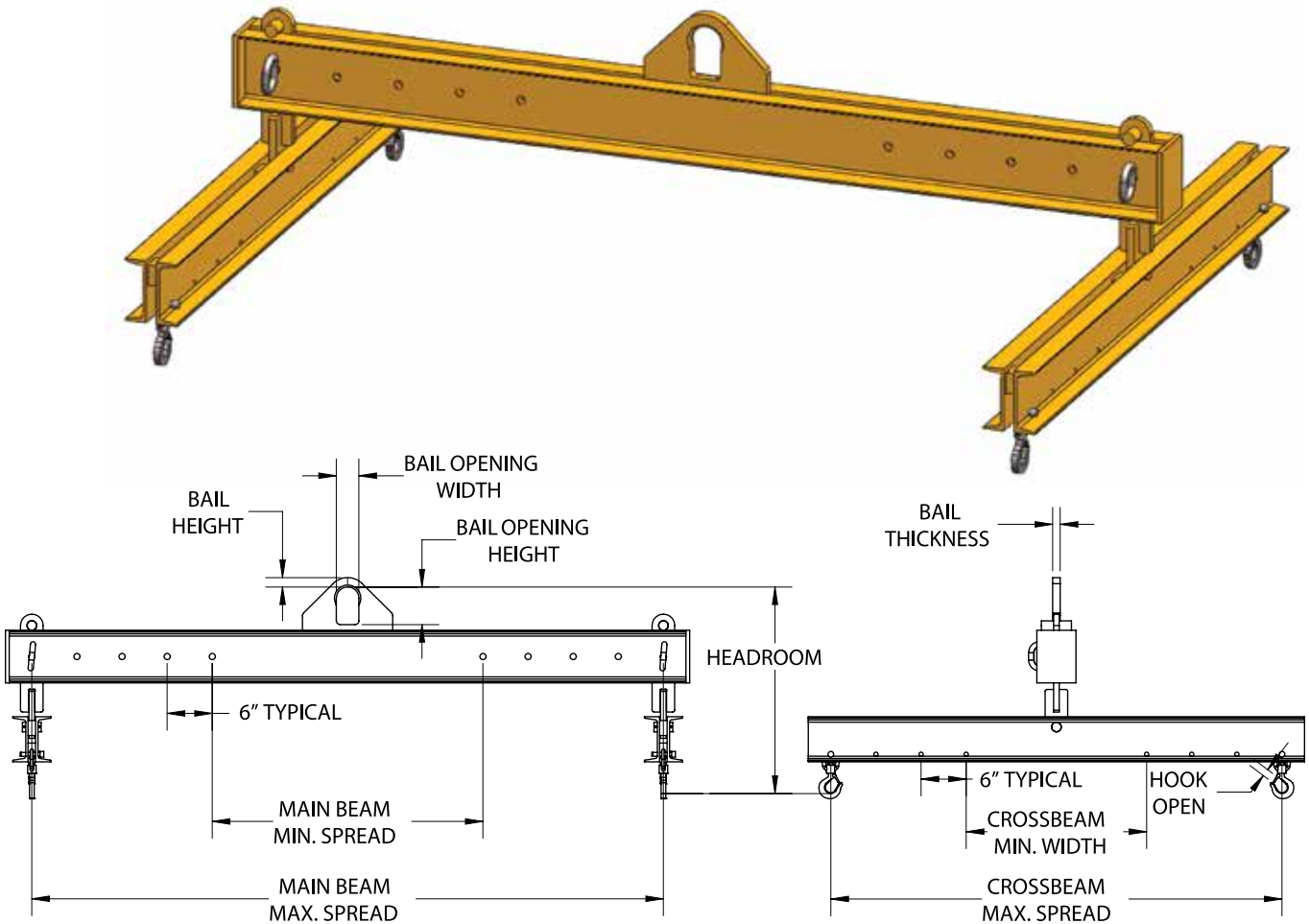

Model #	Capacity (US Tons)*	Main Beam Min/Max Spread	Cross Beam Min/Max Spread	Dimensions (Inches)						Weight (Lbs.)
				Headroom	Bail Height	Bail Opening Width	Bail Opening Height	Bail Thickness	Hook Opening	
HFPAB-3-84/60	3	36/84	24/60	28	1.25	3	5	1	0.91	473
HFPAB-5-120/96	5	48/120	36/96	33	2	4	7	1.25	1	958
HFPAB-10-144/96	10	72/144	36/96	42	2	4	7	1.25	1.36	1928

*1 US Ton = 2,000 lbs.



DO NOT EXCEED CAPACITY!
See the SAFETY GUIDELINES section before using these products. Pages 92–94.

HDCRB DUAL CRANE ROTATING BEAM

FEATURES

- This style of lifting beam is designed to be utilized with dual hoists and can rotate the load parallel.
- Designed to meet your specific lifting requirements.
- Engineered and manufactured to ASME B30.20 & BTH-1 Design Category B Service Class 2.
- 100% of ALL lifting beams are Proof-Tested to 125% capacity and certificates supplied at No Additional Charge.
- Made in USA.

OPTIONS

- Manual or motorized beam rotation
- Dual hooks
- J-Hooks
- Low headroom bail
- Swivel hooks
- Shackle lugs
- Faspins
- Beam stand

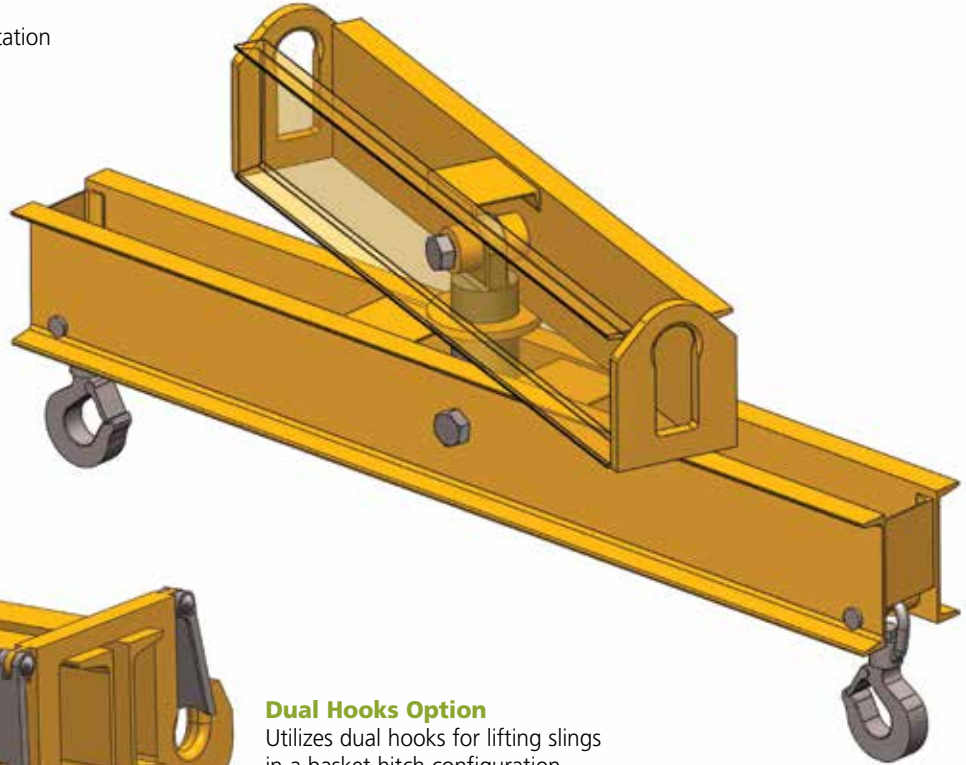

Dual Hooks Option

Utilizes dual hooks for lifting slings in a basket hitch configuration.

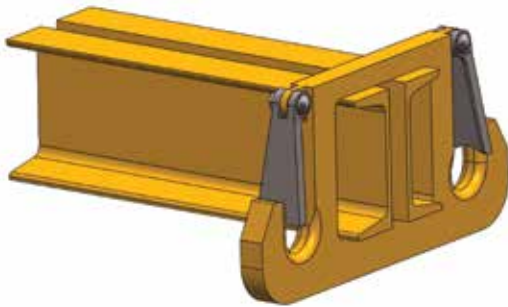

J-Hooks Option

Utilized when lifting rolls by the mandrel or shaft.

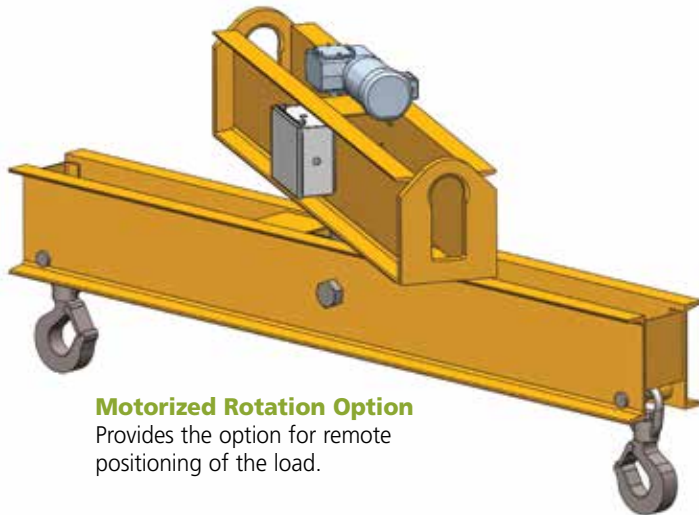

Motorized Rotation Option

Provides the option for remote positioning of the load.



HCGCLB CHLORINE GAS CYLINDER LIFTING BEAM

FEATURES

- This style of lifting beam is designed to lift chlorine gas cylinders.
- Low headroom design.
- Smooth edge design to minimize wear on lifting straps.
- Engineered and manufactured to ASME B30.20 & BTH-1 Design Category B Service Class 2.
- 100% of ALL lifting beams are Proof-Tested to 125% capacity and certificates supplied at No Additional Charge.
- Made in USA.

OPTIONS

- Additional sizes are available

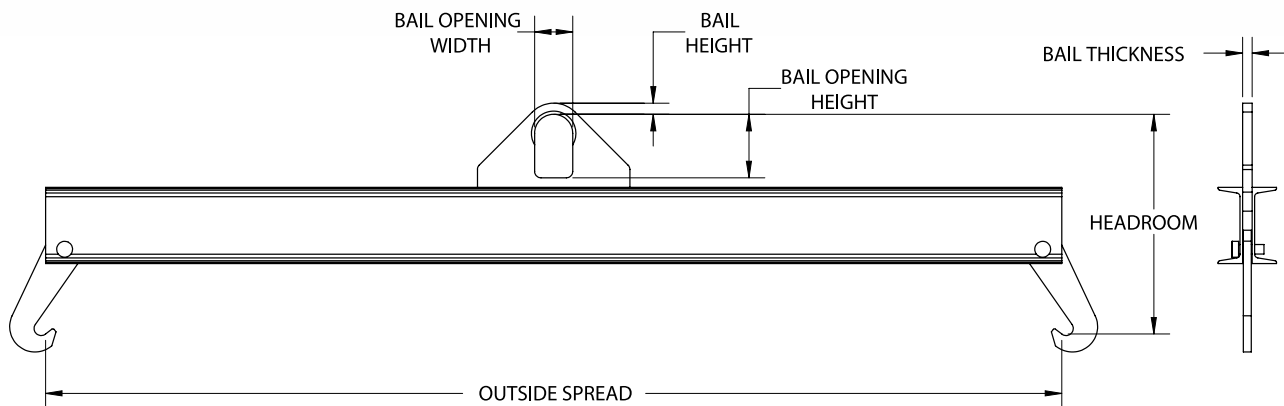
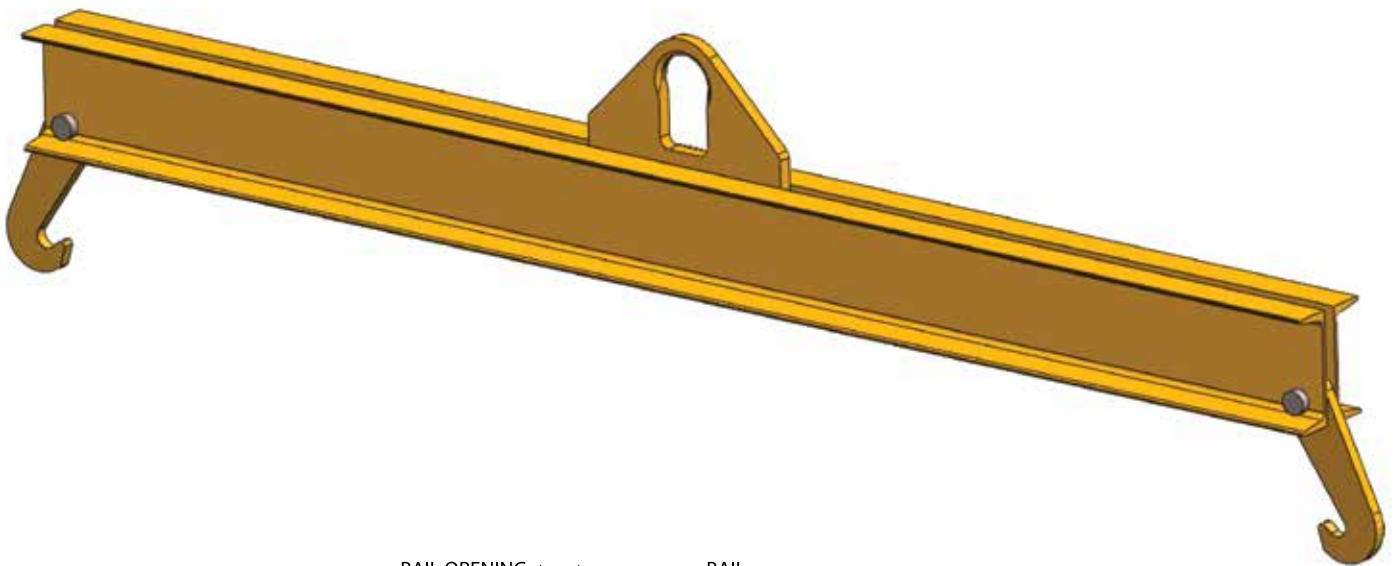

Model #	Capacity (US Tons)*	Dimensions (Inches)						Weight (Lbs.)
		Outside Spread	Headroom	Bail Height	Bail Opening Width	Bail Opening Height	Bail Thickness	
HCGCLB-2-80/82	2	80.75 - 82.25	18.5 - 17.5	0.88	3	5	0.75	125

*1 US Ton = 2,000 lbs.



WARNING

DO NOT EXCEED CAPACITY!
See the SAFETY GUIDELINES section before using these products. Pages 92-94.

LIFTING BEAMS

Custom Application Form



For pricing information: Fax completed form & contact info to 717-665-2861 or email Customer Service at customerservice@harringtonhoists.com

LOAD INFORMATION:

Describe the material you are planning to lift: _____

Lifting Beam Stand Required: Yes No

Total Number of Lifting Points: _____ Spacing Between Points _____

Is The CG (center of gravity) Of The Load Between Outer Lifting Points:
 Yes No If No, Describe CG Location _____

Type Of Rigging Used To Attach To Load: Swivel Hooks Shackles
Slings (specific type) _____ Other (specific type) _____

Load Dimensions:

	Min (in)	Max (in)
Height	_____	_____
Width	_____	_____
Length	_____	_____
Weight	_____	_____

CRANE SPECIFICATIONS:

Crane Configuration: Single Double

Distance Between Top Of The Load To The Crane Hook High Position(s): _____

Capacity Of The Crane(s): _____ Distance Between Cranes (if applicable): _____

Required Duty Cycle Of The Lifting Beam: Lifts Per Hour _____ Lifts Per Day _____

Crane Classification(s): A B C D E F

DUAL CRANE ROTATING BEAM APPLICATION:

Operation: Manual Motorized: AC DC Voltage _____ Phase _____ Cycle _____

Controls Required: Yes No If Yes: Specify Type _____ Furnish Loose Mounted On Lifter

CRANE HOOK SPECIFICATIONS (Inches) :

A:___ B:___ C:___ D:___ E:___ F:___ G:___ H:___

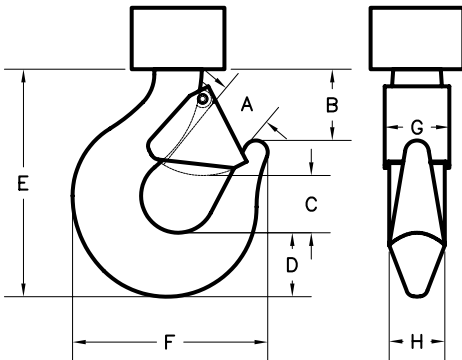

Please provide pertinent application information not supplied above (extreme product or operating temperature, extreme environmental conditions such as temperature or moisture, space or headroom restrictions, additional specifications):

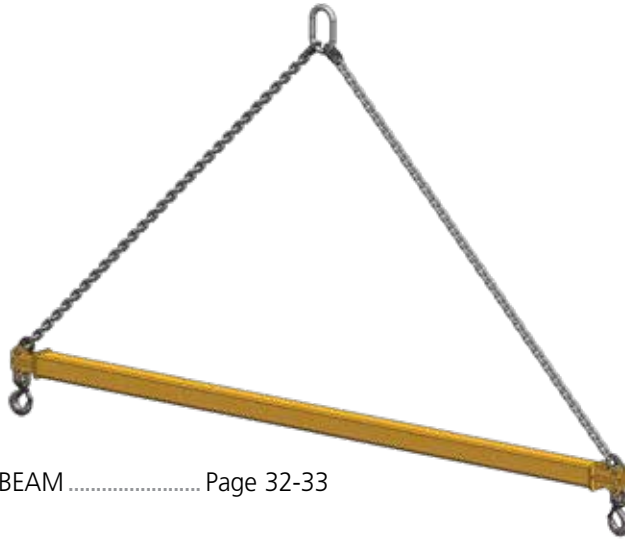

HSDSB

STANDARD DUTY SPREADER BEAM Page 32-33

HATSB

ADJUSTABLE TELESCOPIC SPREADER BEAM Page 34



HBXSB

BOX SPREADER BEAM Page 35



HECSB

END CAP SPREADER BEAM Page 36-41



HSDSB STANDARD DUTY SPREADER BEAM

SPREADER BEAMS

FEATURES

- This style of lifter is utilized with upper rigging spread between two lift points that adds extra stability to the lift.
- This spreader beam should be utilized where headroom is not limited and comes standard with a pair of swivel hooks.
- Can be supplied with optional chain or wire rope top rigging.
- Engineered and manufactured to ASME B30.20 & BTH-1 Design Category B Service Class 2.
- 100% of ALL spreader beams are Proof-Tested to 125% capacity and certificates supplied at No Additional Charge.
- Made in USA.

OPTIONS

- Higher capacities
- Additional lengths
- Upper and lower shackle design
- Chain top rigging
- Wire rope top rigging



Upper and Lower Shackle Option
Utilizes dual upper and lower shackles for connecting the rigging.

Model #	Capacity (US Tons)*	Outside Spread (Ft.)	Dimensions (Inches)				Weight (Lbs.)	
			Headroom	Oblong ML Diameter	Oblong ML Opening Width	Oblong ML Opening Height		Hook Opening
HSDSB-2-4	2	4	36	0.63	3	6	0.91	45
HSDSB-2-6	2	6	48	0.63	3	6	0.91	60
HSDSB-2-8	2	8	61	0.63	3	6	0.91	82
HSDSB-2-10	2	10	74	0.63	3	6	0.91	95
HSDSB-2-12	2	12	86	0.63	3	6	0.91	115
HSDSB-2-16	2	16	111	0.63	3	6	0.91	225
HSDSB-2-20	2	20	139	0.63	3	6	0.91	408
HSDSB-2-24	2	24	164	0.63	3	6	0.91	445
HSDSB-5-4	5	4	39	1	3.5	7	1.36	62
HSDSB-5-6	5	6	51	1	3.5	7	1.36	78
HSDSB-5-8	5	8	64	1	3.5	7	1.36	100
HSDSB-5-10	5	10	77	1	3.5	7	1.36	117
HSDSB-5-12	5	12	87	1	3.5	7	1.36	168
HSDSB-5-16	5	16	116	1	3.5	7	1.36	305
HSDSB-5-20	5	20	141	1	3.5	7	1.36	435
HSDSB-5-24	5	24	166	1	3.5	7	1.36	661
HHSDSB-10-4	10	4	43	1.25	4.38	8.75	1.61	100
HHSDSB-10-6	10	6	56	1.25	4.38	8.75	1.61	122
HSDSB-10-8	10	8	67	1.25	4.38	8.75	1.61	156
HSDSB-10-10	10	10	81	1.25	4.38	8.75	1.61	180
HSDSB-10-12	10	12	90	1.25	4.38	8.75	1.61	240
HSDSB-10-16	10	16	119	1.25	4.38	8.75	1.61	380
HSDSB-10-20	10	20	145	1.25	4.38	8.75	1.61	532
HSDSB-10-24	10	24	171	1.25	4.38	8.75	1.61	915
HSDSB-15-4	15	4	45	1.5	5.25	10.5	2.08	126
HSDSB-15-6	15	6	58	1.5	5.25	10.5	2.08	155

*1 US Ton = 2,000 lbs.

cont.



SPREADER BEAMS

SPREADER BEAMS

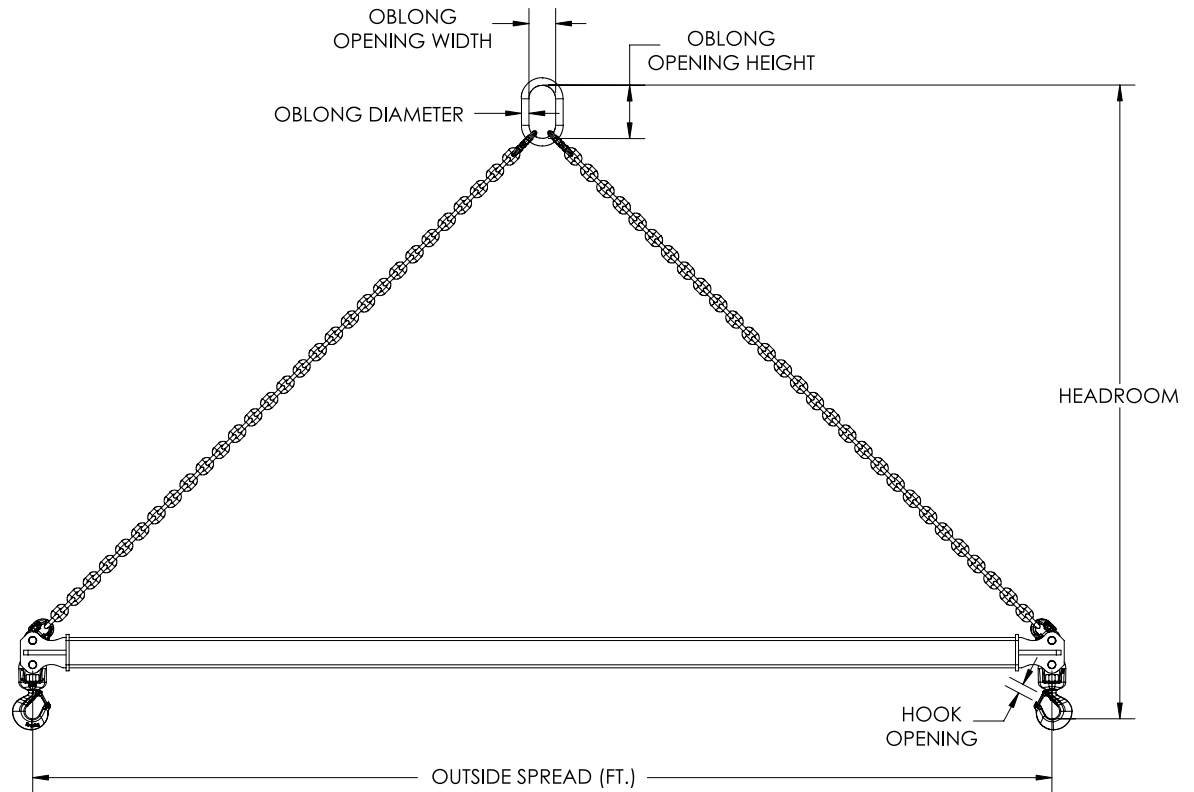

Model #	Capacity (US Tons)*	Outside Spread (Ft.)	Dimensions (Inches)					Weight (Lbs.)
			Headroom	Oblong ML Diameter	Oblong ML Opening Width	Oblong ML Opening Height	Hook Opening	
HSDSB-15-8	15	8	68	1.5	5.25	10.5	2.08	185
HSDSB-15-10	15	10	84	1.5	5.25	10.5	2.08	242
HSDSB-15-12	15	12	97	1.5	5.25	10.5	2.08	270
HSDSB-15-16	15	16	122	1.5	5.25	10.5	2.08	420
HSDSB-15-20	15	20	147	1.5	5.25	10.5	2.08	665
HSDSB-15-24	15	24	175	1.5	5.25	10.5	2.08	953
HSDSB-20-4	20	4	48	1.75	6	12	2.27	170
HSDSB-20-6	20	6	61	1.75	6	12	2.27	200
HSDSB-20-8	20	8	72	1.75	6	12	2.27	233
HSDSB-20-10	20	10	86	1.75	6	12	2.27	315
HSDSB-20-12	20	12	99	1.75	6	12	2.27	350
HSDSB-20-16	20	16	124	1.75	6	12	2.27	540
HSDSB-20-20	20	20	147	1.75	6	12	2.27	775
HSDSB-20-24	20	24	179	1.75	6	12	2.27	1341
HSDSB-30-6	30	6	63	1.75	6	12	2.27	285
HSDSB-30-8	30	8	74	1.75	6	12	2.27	402
HSDSB-30-10	30	10	87	1.75	6	12	2.27	440
HSDSB-30-12	30	12	100	1.75	6	12	2.27	530
HSDSB-30-16	30	16	126	1.75	6	12	2.27	888
HSDSB-30-20	30	20	152	1.75	6	12	2.27	1390
HSDSB-40-6	40	6	68	2	7	14	3.02	563
HSDSB-40-8	40	8	81	2	7	14	3.02	695
HSDSB-40-10	40	10	93	2	7	14	3.02	781
HSDSB-40-12	40	12	107	2	7	14	3.02	1058
HSDSB-40-16	40	16	133	2	7	14	3.02	1364

*1 US Ton = 2,000 lbs.



DO NOT EXCEED CAPACITY!
See the SAFETY GUIDELINES section before using these products. Pages 92–94.

HATSB ADJUSTABLE TELESCOPIC SPREADER BEAM

SPREADER BEAMS

FEATURES

- This style of spreader beam is telescopic to accommodate various load sizes – 2 through 15 ton capacities, adjustable increments at 1" and 20 through 40 ton capacities, adjustable increments at 12".
- This style of lifter is utilized with upper rigging spread between two lift points that adds extra stability to the lift.
- This spreader beam should be utilized where headroom is not limited and comes standard with a pair of swivel hooks.
- Can be supplied with optional chain or wire rope top rigging.
- Engineered and manufactured to ASME B30.20 & BTH-1 Design Category B Service Class 2.
- 100% of ALL spreader beams are Proof-Tested to 125% capacity and certificates supplied at No Additional Charge.
- Made in USA.

OPTIONS

- Higher capacities
- Additional lengths
- Upper and lower shackle design
- Chain top rigging
- Wire rope top rigging

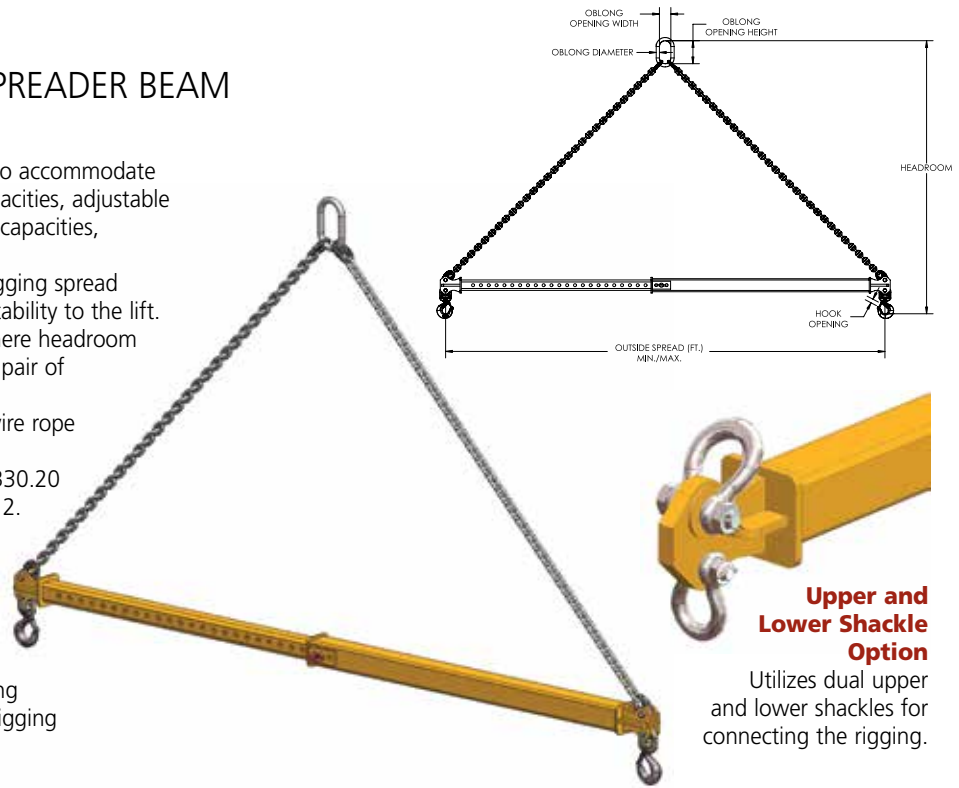

Upper and Lower Shackle Option
Utilizes dual upper and lower shackles for connecting the rigging.

Model #	Capacity (US Tons)*	Outside Spread Min/Max (Ft.)	Dimensions (Inches)					Beam & Hook Weight (Lbs.)	Chain Rigging Weight (Lbs.)
			Headroom Min/Max	Oblong ML Diameter	Oblong ML Opening Width	Oblong ML Opening Height	Hook Opening		
HATSB-2-4/6	2	4/6	50/60	0.63	3	6	0.91	70	9
HATSB-2-6/10	2	6/10	76/92	0.63	3	6	0.91	85	13
HATSB-2-8/14	2	8/14	101/119	0.63	3	6	0.91	175	17
HATSB-2-12/20	2	12/20	139/174	0.63	3	6	0.91	245	23
HATSB-5-4/6	5	4/6	58/67	1	3.5	7	1.36	105	34
HATSB-5-6/10	5	6/10	83/100	1	3.5	7	1.36	160	47
HATSB-5-8/14	5	8/14	107/132	1	3.5	7	1.36	205	61
HATSB-5-12/20	5	12/20	145/181	1	3.5	7	1.36	670	82
HATSB-10-4/6	10	4/6	63/72	1.25	4.38	8.75	1.61	95	49
HATSB-10-6/10	10	6/10	78/117	1.25	4.38	8.75	1.61	175	69
HATSB-10-8/14	10	8/14	113/139	1.25	4.38	8.75	1.61	460	88
HATSB-10-12/20	10	12/20	151/171	1.25	4.38	8.75	1.61	680	118
HATSB-15-4/6	15	4/6	67/76	1.5	5.25	10.5	2.08	165	78
HATSB-15-6/10	15	6/10	91/109	1.5	5.25	10.5	2.08	365	111
HATSB-15-8/14	15	8/14	117/142	1.5	5.25	10.5	2.08	478	145
HATSB-15-12/20	15	12/20	154/189	1.5	5.25	10.5	2.08	700	194
HATSB-20-7/11	20	7/11	98/112	1.75	6	12	2.27	430	175
HATSB-20-9/15	20	9/15	129/151	1.75	6	12	2.27	540	225
HATSB-20-12/20	20	12/20	159/189	1.75	6	12	2.27	822	275
HATSB-25-7/11	25	7/11	103/112	2	7	14	3.02	430	240
HATSB-25-9/15	25	9/15	125/148	2	7	14	3.02	540	295
HATSB-25-12/20	25	12/20	156/188	2	7	14	3.02	825	365
HATSB-30-7/11	30	7/11	107/121	2	7	14	3.02	615	240
HATSB-30-9/15	30	9/15	130/152	2	7	14	3.02	750	295
HATSB-30-12/20	30	12/20	162/192	2	7	14	3.02	1065	365
HATSB-40-7/11	40	7/11	110/124	2.25	8	16	3.02	620	375
HATSB-40-9/15	40	9/15	133/155	2.25	8	16	3.02	840	470
HATSB-40-12/20	40	12/20	162/193	2.25	8	16	3.02	1500	565

*1 US Ton = 2,000 lbs.



HBXSB BOX SPREADER BEAM

FEATURES

- This style of spreader beam is designed to lift large bulky loads and can be rigged to handle objects with an offset center of gravity.
- Designed to meet your specific lifting requirements and can be manufactured in a welded or bolt together design.
- Product shown is as a bolt-together style with special corner assemblies whereby the shackle lugs can rotate into position in order to prevent side loading.
- If adjustability is required, this style of box spreader beam can be designed with telescopic lengths and/or widths to accommodate various load sizes.
- This spreader beam should be utilized where headroom is not limited.
- This style of lifter is utilized with upper rigging spread between four lift points that adds extra stability to the lift.
- Can be supplied with chain or wire rope top rigging.
- Engineered and manufactured to ASME B30.20 & BTH-1 Design Category B Service Class 2.
- 100% of ALL spreader beams are Proof-Tested to 125% capacity and certificates supplied at No Additional Charge.
- Made in USA.

OPTIONS

- Swivel hooks
- Shackles
- Chain slings
- Other special lifting attachments
- Chain top rigging
- Wire rope top rigging



WARNING

DO NOT EXCEED CAPACITY!
See the SAFETY GUIDELINES section before using these products. Pages 92–94.

HECSB END CAP SPREADER BEAM

SPREADER BEAMS

FEATURES

- This style of lifter is utilized with upper rigging spread between two lift points that adds extra stability to the lift.
- This spreader beam should be utilized where headroom is not limited and comes standard with upper and lower shackles.
- Standard pivoting lifting lugs provide the flexibility of a 75° to 90° lower rigging angle.
- Can be supplied with optional chain or wire rope top rigging.
- Engineered and manufactured in accordance to ASME B30.20 & BTH-1 Design Category B Service Class 2.
- 100% of ALL end cap spreader beams are Proof-Tested to 125% capacity and certificates supplied at No Additional Charge.
- Made in USA.

OPTIONS

- Higher capacities
- Additional lengths
- Chain top rigging
- Wire rope top rigging

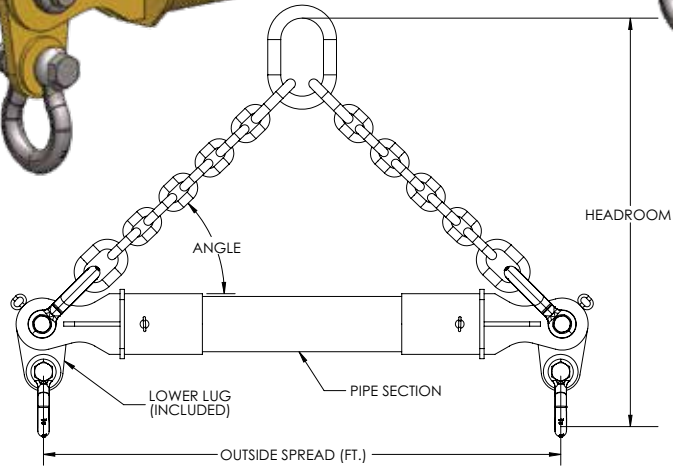

Model #	Capacity (US Tons)*	Outside Spread (Ft.)	End Cap Model #	Pipe Size	Dimensions (Inches)					Top Shackle (US Tons)*	Bottom Shackle (US Tons)*	Weight (Lbs)
					Head-room at 45°	Head-room at 60°	Oblong ML Diameter	Oblong ML Opening Width	Oblong ML Opening Height			
HECSB-5-6	5	6	EC-5-25	5" SCH 80	60	86	1	3.5	7	17	13.5	384
HECSB-5-8	5	8	EC-5-25	5" SCH 80	72	106	1	3.5	7	17	13.5	426
HECSB-5-10	5	10	EC-5-25	5" SCH 80	84	128	1	3.5	7	17	13.5	467
HECSB-5-12	5	12	EC-5-25	5" SCH 80	96	148	1	3.5	7	17	13.5	509
HECSB-5-16	5	16	EC-5-25	5" SCH 80	120	192	1	3.5	7	17	13.5	592
HECSB-5-20	5	20	EC-5-25	5" SCH 80	144	232	1	3.5	7	17	13.5	675
HECSB-5-24	5	24	EC-5-25	5" SCH 80	168	274	1	3.5	7	17	13.5	758
HECSB-5-28	5	28	EC-5-25	5" SCH 80	192	316	1	3.5	7	17	13.5	841
HECSB-5-32	5	32	EC-8-50	8" SCH 80	224	364	1	3.5	7	35	25	1753
HECSB-5-36	5	36	EC-8-50	8" SCH 80	248	406	1	3.5	7	35	25	1927
HECSB-5-40	5	40	EC-8-50	8" SCH 80	272	446	1	3.5	7	35	25	2100
HECSB-10-6	10	6	EC-5-25	5" SCH 80	60	86	1.25	4.38	8.75	17	13.5	384
HECSB-10-8	10	8	EC-5-25	5" SCH 80	72	106	1.25	4.38	8.75	17	13.5	426
HECSB-10-10	10	10	EC-5-25	5" SCH 80	84	128	1.25	4.38	8.75	17	13.5	467
HECSB-10-12	10	12	EC-5-25	5" SCH 80	96	148	1.25	4.38	8.75	17	13.5	509
HECSB-10-16	10	16	EC-5-25	5" SCH 80	120	192	1.25	4.38	8.75	17	13.5	592
HECSB-10-20	10	20	EC-5-25	5" SCH 80	144	232	1.25	4.38	8.75	17	13.5	675
HECSB-10-24	10	24	EC-5-25	5" SCH 80	168	274	1.25	4.38	8.75	17	13.5	758
HECSB-10-28	10	28	EC-5-25	5" SCH 80	N/A	316	1.25	4.38	8.75	17	13.5	841
HECSB-10-32	10	32	EC-8-50	8" SCH 80	224	364	1.25	4.38	8.75	35	25	1753
HECSB-10-36	10	36	EC-8-50	8" SCH 80	248	406	1.25	4.38	8.75	35	25	1927
HECSB-10-40	10	40	EC-8-50	8" SCH 80	272	446	1.25	4.38	8.75	35	25	2100

*1 US Ton = 2,000 lbs.

cont.



DO NOT EXCEED CAPACITY!
See the SAFETY GUIDELINES section before using these products. Pages 92–94.

END CAP SPREADER BEAM cont.

Model #	Capacity (US Tons)*	Outside Spread (Ft.)	End Cap Model #	Pipe Size	Dimensions (Inches)					Top Shackle (US Tons)*	Bottom Shackle (US Tons)*	Weight (Lbs)
					Head-room at 45°	Head-room at 60°	Oblong ML Diameter	Oblong ML Opening Width	Oblong ML Opening Height			
HECSB-15-6	15	6	EC-5-25	5" SCH 80	60	86	1.5	5.25	10.5	17	13.5	384
HECSB-15-8	15	8	EC-5-25	5" SCH 80	72	106	1.5	5.25	10.5	17	13.5	426
HECSB-15-10	15	10	EC-5-25	5" SCH 80	84	128	1.5	5.25	10.5	17	13.5	467
HECSB-15-12	15	12	EC-5-25	5" SCH 80	96	148	1.5	5.25	10.5	17	13.5	509
HECSB-15-16	15	16	EC-5-25	5" SCH 80	120	192	1.5	5.25	10.5	17	13.5	592
HECSB-15-20	15	20	EC-5-25	5" SCH 80	N/A	232	1.5	5.25	10.5	17	13.5	675
HECSB-15-24	15	24	EC-5-25	5" SCH 80	N/A	274	1.5	5.25	10.5	17	13.5	758
HECSB-15-28	15	28	EC-8-50	8" SCH 80	200	324	1.5	5.25	10.5	35	25	1580
HECSB-15-32	15	32	EC-8-50	8" SCH 80	224	364	1.5	5.25	10.5	35	25	1753
HECSB-15-36	15	36	EC-8-50	8" SCH 80	248	406	1.5	5.25	10.5	35	25	1927
HECSB-15-40	15	40	EC-8-50	8" SCH 80	272	446	1.5	5.25	10.5	35	25	2100
HECSB-20-6	20	6	EC-5-25	5" SCH 80	60	86	1.75	6	12	17	13.5	384
HECSB-20-8	20	8	EC-5-25	5" SCH 80	72	106	1.75	6	12	17	13.5	426
HECSB-20-10	20	10	EC-5-25	5" SCH 80	84	128	1.75	6	12	17	13.5	467
HECSB-20-12	20	12	EC-5-25	5" SCH 80	96	148	1.75	6	12	17	13.5	509
HECSB-20-16	20	16	EC-5-25	5" SCH 80	N/A	192	1.75	6	12	17	13.5	592
HECSB-20-20	20	20	EC-5-25	5" SCH 80	N/A	232	1.75	6	12	17	13.5	675
HECSB-20-24	20	24	EC-8-50	8" SCH 80	176	282	1.75	6	12	35	25	1406
HECSB-20-28	20	28	EC-8-50	8" SCH 80	200	324	1.75	6	12	35	25	1580
HECSB-20-32	20	32	EC-8-50	8" SCH 80	224	364	1.75	6	12	35	25	1753
HECSB-20-36	20	36	EC-8-50	8" SCH 80	N/A	406	1.75	6	12	35	25	1927
HECSB-20-40	20	40	EC-8-50	8" SCH 80	N/A	446	1.75	6	12	35	25	2100
HECSB-25-6	25	6	EC-5-25	5" SCH 80	60	86	1.75	6	12	17	13.5	384
HECSB-25-8	25	8	EC-5-25	5" SCH 80	72	106	1.75	6	12	17	13.5	426
HECSB-25-10	25	10	EC-5-25	5" SCH 80	84	128	1.75	6	12	17	13.5	467
HECSB-25-12	25	12	EC-5-25	5" SCH 80	96	148	1.75	6	12	17	13.5	509
HECSB-25-16	25	16	EC-5-25	5" SCH 80	N/A	192	1.75	6	12	17	13.5	592
HECSB-25-20	25	20	EC-8-50	8" SCH 80	N/A	232	1.75	6	12	35	25	1232
HECSB-25-24	25	24	EC-8-50	8" SCH 80	176	282	1.75	6	12	35	25	1406
HECSB-25-28	25	28	EC-8-50	8" SCH 80	200	324	1.75	6	12	35	25	1580
HECSB-25-32	25	32	EC-8-50	8" SCH 80	224	364	1.75	6	12	35	25	1753
HECSB-25-36	25	36	EC-8-50	8" SCH 80	N/A	406	1.75	6	12	35	25	1927
HECSB-25-40	25	40	EC-8-50	8" SCH 80	N/A	446	1.75	6	12	35	25	2100
HECSB-30-6	30	6	EC-5-50	5" SCH 80	68	94	1.75	6	12	35	25	450
HECSB-30-8	30	8	EC-5-50	5" SCH 80	N/A	114	1.75	6	12	35	25	492
HECSB-30-10	30	10	EC-5-50	5" SCH 80	N/A	136	1.75	6	12	35	25	533
HECSB-30-12	30	12	EC-5-50	5" SCH 80	N/A	156	1.75	6	12	35	25	575
HECSB-30-16	30	16	EC-8-50	8" SCH 80	128	200	1.75	6	12	35	25	1059
HECSB-30-20	30	20	EC-8-50	8" SCH 80	152	240	1.75	6	12	35	25	1232
HECSB-30-24	30	24	EC-8-50	8" SCH 80	176	282	1.75	6	12	35	25	1406
HECSB-30-28	30	28	EC-8-50	8" SCH 80	200	324	1.75	6	12	35	25	1580
HECSB-30-32	30	32	EC-8-50	8" SCH 80	224	364	1.75	6	12	35	25	1753
HECSB-30-36	30	36	EC-8-50	8" SCH 80	N/A	406	1.75	6	12	35	25	1927
HECSB-30-40	30	40	EC-12-80	12" SCH 80	278	452	1.75	6	12	55	55	4184
HECSB-40-6	40	6	EC-5-50	5" SCH 80	N/A	94	2.25	8	16	35	25	450
HECSB-40-8	40	8	EC-5-50	5" SCH 80	N/A	114	2.25	8	16	35	25	492
HECSB-40-10	40	10	EC-8-50	8" SCH 80	92	136	2.25	8	16	35	25	798
HECSB-40-12	40	12	EC-8-50	8" SCH 80	104	156	2.25	8	16	35	25	885
HECSB-40-16	40	16	EC-8-50	8" SCH 80	128	200	2.25	8	16	35	25	1059
HECSB-40-20	40	20	EC-8-50	8" SCH 80	152	240	2.25	8	16	35	25	1232
HECSB-40-24	40	24	EC-8-50	8" SCH 80	176	282	2.25	8	16	35	25	1406
HECSB-40-28	40	28	EC-8-50	8" SCH 80	N/A	324	2.25	8	16	35	25	1580
HECSB-40-32	40	32	EC-8-50	8" SCH 80	N/A	364	2.25	8	16	35	25	1753
HECSB-40-36	40	36	EC-12-80	12" SCH 80	254	412	2.25	8	16	55	55	3830
HECSB-40-40	40	40	EC-12-80	12" SCH 80	278	452	2.25	8	16	55	55	4184

*1 US Ton = 2,000 lbs.



DO NOT EXCEED CAPACITY!
See the SAFETY GUIDELINES section before using these products. Pages 92–94.

LIFTING EQUIPMENT

SPREADER BEAMS



HECSB

END CAP SPREADER BEAM cont.

Model #	Capacity (US Tons)*	Outside Spread (Ft.)	End Cap Model #	Pipe Size	Dimensions (Inches)					Top Shackle (US Tons)*	Bottom Shackle (US Tons)*	Weight (Lbs)
					Head-room at 45°	Head-room at 60°	Oblong ML Diameter	Oblong ML Opening Width	Oblong ML Opening Height			
HECSB-50-6	50	6	EC-5-50	5" SCH 80	N/A	94	2.25	8	16	35	25	450
HECSB-50-8	50	8	EC-5-50	5" SCH 80	N/A	114	2.25	8	16	35	25	492
HECSB-50-10	50	10	EC-8-50	8" SCH 80	92	136	2.25	8	16	35	25	798
HECSB-50-12	50	12	EC-8-50	8" SCH 80	104	156	2.25	8	16	35	25	885
HECSB-50-16	50	16	EC-8-50	8" SCH 80	128	200	2.25	8	16	35	25	1059
HECSB-50-20	50	20	EC-8-50	8" SCH 80	152	240	2.25	8	16	35	25	1232
HECSB-50-24	50	24	EC-8-50	8" SCH 80	N/A	282	2.25	8	16	35	25	1406
HECSB-50-28	50	28	EC-8-50	8" SCH 80	N/A	324	2.25	8	16	35	25	1580
HECSB-50-32	50	32	EC-8-50	8" SCH 80	N/A	364	2.25	8	16	35	25	1753
HECSB-50-36	50	36	EC-12-80	12" SCH 80	254	412	2.25	8	16	55	55	3830
HECSB-50-40	50	40	EC-12-80	12" SCH 80	278	452	2.25	8	16	55	55	4184
HECSB-60-8	60	8	EC-8-80	8" SCH 80	84	120	2.5	8	16	55	55	896
HECSB-60-10	60	10	EC-8-80	8" SCH 80	96	140	2.5	8	16	55	55	982
HECSB-60-12	60	12	EC-8-80	8" SCH 80	108	162	2.5	8	16	55	55	1069
HECSB-60-16	60	16	EC-8-80	8" SCH 80	132	204	2.5	8	16	55	55	1243
HECSB-60-20	60	20	EC-8-80	8" SCH 80	N/A	246	2.5	8	16	55	55	1416
HECSB-60-24	60	24	EC-8-80	8" SCH 80	N/A	286	2.5	8	16	55	55	1590
HECSB-60-28	60	28	EC-8-80	8" SCH 80	N/A	328	2.5	8	16	55	55	1764
HECSB-60-32	60	32	EC-8-80	8" SCH 80	N/A	370	2.5	8	16	55	55	1937
HECSB-60-36	60	36	EC-12-80	12" SCH 80	254	412	2.5	8	16	55	55	3830
HECSB-60-40	60	40	EC-12-80	12" SCH 80	278	452	2.5	8	16	55	55	4184
HECSB-70-8	70	8	EC-8-80	8" SCH 80	84	120	2.75	9	16	55	55	896
HECSB-70-10	70	10	EC-8-80	8" SCH 80	96	140	2.75	9	16	55	55	982
HECSB-70-12	70	12	EC-8-80	8" SCH 80	N/A	162	2.75	9	16	55	55	1069
HECSB-70-16	70	16	EC-8-80	8" SCH 80	N/A	204	2.75	9	16	55	55	1243
HECSB-70-20	70	20	EC-12-80	12" SCH 80	156	246	2.75	9	16	55	55	2413
HECSB-70-24	70	24	EC-12-80	12" SCH 80	180	286	2.75	9	16	55	55	2769
HECSB-70-28	70	28	EC-12-80	12" SCH 80	204	328	2.75	9	16	55	55	3122
HECSB-70-32	70	32	EC-12-80	12" SCH 80	230	370	2.75	9	16	55	55	3476
HECSB-70-36	70	36	EC-12-80	12" SCH 80	254	412	2.75	9	16	55	55	3830
HECSB-70-40	70	40	EC-12-80	12" SCH 80	278	452	2.75	9	16	55	55	4184
HECSB-80-8	80	8	EC-8-80	8" SCH 80	84	120	3.25	10	20	55	55	896
HECSB-80-10	80	10	EC-8-80	8" SCH 80	N/A	140	3.25	10	20	55	55	982
HECSB-80-12	80	12	EC-8-80	8" SCH 80	N/A	162	3.25	10	20	55	55	1069
HECSB-80-16	80	16	EC-8-80	8" SCH 80	N/A	204	3.25	10	20	55	55	1243
HECSB-80-20	80	20	EC-12-80	12" SCH 80	156	246	3.25	10	20	55	55	2413
HECSB-80-24	80	24	EC-12-80	12" SCH 80	180	286	3.25	10	20	55	55	2768
HECSB-80-28	80	28	EC-12-80	12" SCH 80	204	328	3.25	10	20	55	55	3122
HECSB-80-32	80	32	EC-12-80	12" SCH 80	230	370	3.25	10	20	55	55	3476
HECSB-80-36	80	36	EC-12-80	12" SCH 80	254	412	3.25	10	20	55	55	3830
HECSB-80-40	80	40	EC-12-80	12" SCH 80	278	452	3.25	10	20	55	55	4184

*1 US Ton = 2,000 lbs.

cont.



DO NOT EXCEED CAPACITY!
See the SAFETY GUIDELINES section before using these products. Pages 92-94.

END CAP SPREADER BEAM cont.

Model #	Capacity (US Tons)*	Outside Spread (Ft.)	End Cap Model #	Pipe Size	Dimensions (Inches)					Top Shackle (US Tons)*	Bottom Shackle (US Tons)*	Weight (Lbs)
					Head-room at 45°	Head-room at 60°	Oblong ML Diameter	Oblong ML Opening Width	Oblong ML Opening Height			
HECSB-90-8	90	8	EC-12-110	12" SCH 80	84	120	3.25	10	20	85	55	1519
HECSB-90-10	90	10	EC-12-110	12" SCH 80	96	140	3.25	10	20	85	55	1696
HECSB-90-12	90	12	EC-12-110	12" SCH 80	108	162	3.25	10	20	85	55	1873
HECSB-90-16	90	16	EC-12-110	12" SCH 80	132	204	3.25	10	20	85	55	2227
HECSB-90-20	90	20	EC-12-110	12" SCH 80	156	246	3.25	10	20	85	55	2581
HECSB-90-24	90	24	EC-12-110	12" SCH 80	180	286	3.25	10	20	85	55	2936
HECSB-90-28	90	28	EC-12-110	12" SCH 80	204	328	3.25	10	20	85	55	3290
HECSB-90-32	90	32	EC-12-110	12" SCH 80	230	370	3.25	10	20	85	55	3644
HECSB-90-36	90	36	EC-12-110	12" SCH 80	254	412	3.25	10	20	85	55	3998
HECSB-90-40	90	40	EC-12-110	12" SCH 80	N/A	452	3.25	10	20	85	55	4352
HECSB-100-8	100	8	EC-12-110	12" SCH 80	84	120	3.5	10	20	85	55	1519
HECSB-100-10	100	10	EC-12-110	12" SCH 80	96	140	3.5	10	20	85	55	1696
HECSB-100-12	100	12	EC-12-110	12" SCH 80	108	162	3.5	10	20	85	55	1873
HECSB-100-16	100	16	EC-12-110	12" SCH 80	132	204	3.5	10	20	85	55	2227
HECSB-100-20	100	20	EC-12-110	12" SCH 80	156	246	3.5	10	20	85	55	2581
HECSB-100-24	100	24	EC-12-110	12" SCH 80	180	286	3.5	10	20	85	55	2936
HECSB-100-28	100	28	EC-12-110	12" SCH 80	204	328	3.5	10	20	85	55	3290
HECSB-100-32	100	32	EC-12-110	12" SCH 80	230	370	3.5	10	20	85	55	3644
HECSB-100-36	100	36	EC-12-110	12" SCH 80	N/A	412	3.5	10	20	85	55	3998
HECSB-100-40	100	40	EC-12-110	12" SCH 80	N/A	452	3.5	10	20	85	55	4352
HECSB-110-8	110	8	EC-12-110	12" SCH 80	84	120	3.5	10	20	85	55	1519
HECSB-110-10	110	10	EC-12-110	12" SCH 80	96	140	3.5	10	20	85	55	1696
HECSB-110-12	110	12	EC-12-110	12" SCH 80	108	162	3.5	10	20	85	55	1873
HECSB-110-16	110	16	EC-12-110	12" SCH 80	132	204	3.5	10	20	85	55	2227
HECSB-110-20	110	20	EC-12-110	12" SCH 80	156	246	3.5	10	20	85	55	2581
HECSB-110-24	110	24	EC-12-110	12" SCH 80	180	286	3.5	10	20	85	55	2936
HECSB-110-28	110	28	EC-12-110	12" SCH 80	204	328	3.5	10	20	85	55	3290
HECSB-110-32	110	32	EC-12-110	12" SCH 80	N/A	370	3.5	10	20	85	55	3644
HECSB-110-36	110	36	EC-12-110	12" SCH 80	N/A	412	3.5	10	20	85	55	3998
HECSB-110-40	110	40	EC-12-110	12" SCH 80	N/A	452	3.5	10	20	85	55	4352
HECSB-120-8	120	8	EC-12-130	12" SCH 80	96	130	4	10	20	85	85	1539
HECSB-120-10	120	10	EC-12-130	12" SCH 80	108	152	4	10	20	85	85	1716
HECSB-120-12	120	12	EC-12-130	12" SCH 80	120	172	4	10	20	85	85	1893
HECSB-120-16	120	16	EC-12-130	12" SCH 80	144	216	4	10	20	85	85	2247
HECSB-120-20	120	20	EC-12-130	12" SCH 80	168	256	4	10	20	85	85	2601
HECSB-120-24	120	24	EC-12-130	12" SCH 80	192	298	4	10	20	85	85	2956
HECSB-120-28	120	28	EC-12-130	12" SCH 80	N/A	340	4	10	20	85	85	3310
HECSB-120-32	120	32	EC-12-130	12" SCH 80	N/A	380	4	10	20	85	85	3664
HECSB-120-36	120	36	EC-12-130	12" SCH 80	N/A	422	4	10	20	85	85	4018
HECSB-120-40	120	40	EC-12-130	12" SCH 80	N/A	462	4	10	20	85	85	4372
HECSB-130-8	130	8	EC-12-130	12" SCH 80	96	130	4	10	20	85	85	1539
HECSB-130-10	130	10	EC-12-130	12" SCH 80	108	152	4	10	20	85	85	1716
HECSB-130-12	130	12	EC-12-130	12" SCH 80	120	172	4	10	20	85	85	1893
HECSB-130-16	130	16	EC-12-130	12" SCH 80	144	216	4	10	20	85	85	2247
HECSB-130-20	130	20	EC-12-130	12" SCH 80	168	256	4	10	20	85	85	2601
HECSB-130-24	130	24	EC-12-130	12" SCH 80	N/A	298	4	10	20	85	85	2956
HECSB-130-28	130	28	EC-12-130	12" SCH 80	N/A	340	4	10	20	85	85	3310
HECSB-130-32	130	32	EC-12-130	12" SCH 80	N/A	380	4	10	20	85	85	3664
HECSB-130-36	130	36	EC-12-130	12" SCH 80	N/A	422	4	10	20	85	85	4018

*1 US Ton = 2,000 lbs.

SPREADER BEAMS



DO NOT EXCEED CAPACITY!
See the SAFETY GUIDELINES section before using these products. Pages 92–94.

HEC END CAP

FEATURES

- This style of lifting component supplied in pairs allows the user to assemble their own spreader beam by incorporating A53 Grade B, schedule 80 pipe along with upper and lower rigging.
- This style of spreader beam when assembled adds extra stability to the lift.
- This style of spreader beam when assembled should be utilized where headroom is not limited.
- Standard pivoting lifting lugs provide the flexibility of a 75° to 90° lower rigging angle.
- Includes standard assembly pins used to attach the End Cap to the A53 Grade B, schedule 80 pipe.
- Can be supplied with optional upper and lower shackles.
- Can be supplied with optional chain or wire rope top rigging.
- Engineered and manufactured in accordance to ASME B30.20 & BTH-1 Design Category B Service Class 2 and complies when assembled per factory specifications.
- 100% of ALL end caps are Proof-Tested to 125% capacity and certificates supplied at No Additional Charge.
- Made in USA.

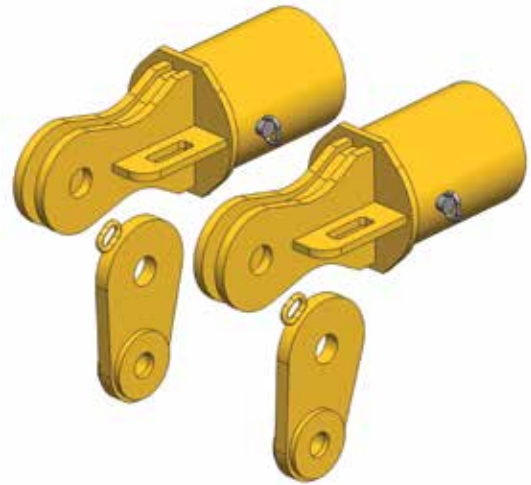

OPTIONS

- Higher capacities
- Chain top rigging
- Upper and lower shackles
- Wire rope top rigging

Model #	Dimensions (US Tons)*			Schedule 80 Pipe Size (In.)	Schedule 80 Wall Thickness (In.)	Weight (Lbs.)
	Max Capacity	Top Shackle	Bottom Shackle			
HEC-5-25	25	17	13.5	5	0.375	312
HEC-5-50	50	35	25	5	0.375	378
HEC-8-50	50	35	25	8	0.500	488
HEC-8-80	80	55	55	8	0.500	672
HEC-12-80	80	55	55	12	0.687	924
HEC-12-110	110	85	55	12	0.687	1092
HEC-12-130	130	85	85	12	0.687	1112

*1 US Ton = 2,000 lbs.

HECP END CAP PIPE

FEATURES

- This style of lifting component, A53 Grade B, schedule 80 pipe, allows the user to assemble their own spreader beam by attaching specified end caps along with upper and lower rigging.
- This style of spreader beam when assembled adds extra stability to the lift.
- This style of spreader beam when assembled should be utilized where headroom is not limited.
- Can be supplied with optional End Caps.
- Can be supplied with optional upper and lower shackles.
- Can be supplied with optional chain or wire rope top rigging.
- Complies with ASME B30.20 & BTH-1 Design Category B Service Class 2 when assembled per factory specifications.
- 100% of ALL end cap pipe is certified to the material specification supplied by the pipe manufacturer as well as for the working load limit that is listed in the End Cap Pipe chart when used in conjunction with the specified End Caps at the appropriate rigging angles.
- Made in USA

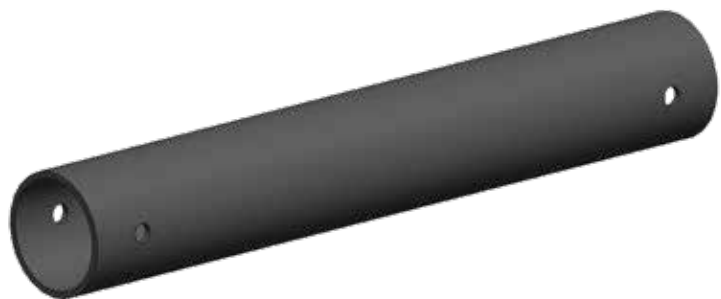

OPTIONS

- Higher capacities
- Upper and lower shackles
- Chain top rigging
- Wire rope top rigging

END CAP PIPE cont.

Model #	End Cap Model #	Pipe Size	Outside Spread (Ft.)	Capacity (US Tons)*	Schedule 80 Wall Thickness (In.)	Weight (Lbs)
HECP-5-6	EC-5-25	5" SCH 80	6	25	0.375	72
	EC-5-50	5" SCH 80	6	50	0.375	72
HECP-5-8	EC-5-25	5" SCH 80	8	25	0.375	114
	EC-5-50	5" SCH 80	8	50	0.375	114
HECP-5-10	EC-5-25	5" SCH 80	10	25	0.375	155
	EC-5-50	5" SCH 80	10	30	0.375	155
HECP-5-12	EC-5-25	5" SCH 80	12	25	0.375	197
	EC-5-50	5" SCH 80	12	30	0.375	197
HECP-5-16	EC-5-25	5" SCH 80	16	25	0.375	280
HECP-5-20	EC-5-25	5" SCH 80	20	20	0.375	363
HECP-5-24	EC-5-25	5" SCH 80	24	15	0.375	446
HECP-5-28	EC-5-25	5" SCH 80	28	10	0.375	529
HECP-8-8	EC-8-80	8" SCH 80	8	80	0.500	224
HECP-8-10	EC-8-50	8" SCH 80	10	50	0.500	310
	EC-8-80	8" SCH 80	10	80	0.500	310
HECP-8-12	EC-8-50	8" SCH 80	12	50	0.500	397
	EC-8-80	8" SCH 80	12	80	0.500	397
HECP-8-16	EC-8-50	8" SCH 80	16	50	0.500	571
	EC-8-80	8" SCH 80	16	80	0.500	571
HECP-8-20	EC-8-50	8" SCH 80	20	50	0.500	744
	EC-8-80	8" SCH 80	20	60	0.500	744
HECP-8-24	EC-8-50	8" SCH 80	24	50	0.500	918
	EC-8-80	8" SCH 80	24	60	0.500	918
HECP-8-28	EC-8-50	8" SCH 80	28	50	0.500	1092
	EC-8-80	8" SCH 80	28	60	0.500	1092
HECP-8-32	EC-8-50	8" SCH 80	32	50	0.500	1265
	EC-8-80	8" SCH 80	32	60	0.500	1265
HECP-8-36	EC-8-50	8" SCH 80	36	30	0.500	1439
HECP-8-40	EC-8-50	8" SCH 80	40	25	0.500	1612
HECP-12-8	EC-12-110	12" SCH 80	8	110	0.687	427
	EC-12-130	12" SCH 80	8	130	0.687	427
HECP-12-10	EC-12-110	12" SCH 80	10	110	0.687	604
	EC-12-130	12" SCH 80	10	130	0.687	604
HECP-12-12	EC-12-110	12" SCH 80	12	110	0.687	781
	EC-12-130	12" SCH 80	12	130	0.687	781
HECP-12-16	EC-12-110	12" SCH 80	16	110	0.687	1135
	EC-12-130	12" SCH 80	16	130	0.687	1135
HECP-12-20	EC-12-80	12" SCH 80	20	80	0.687	1489
	EC-12-110	12" SCH 80	20	110	0.687	1489
HECP-12-24	EC-12-130	12" SCH 80	20	130	0.687	1489
	EC-12-80	12" SCH 80	24	80	0.687	1844
HECP-12-24	EC-12-110	12" SCH 80	24	110	0.687	1844
	EC-12-130	12" SCH 80	24	130	0.687	1844
	EC-12-130	12" SCH 80	24	130	0.687	1844
HECP-12-28	EC-12-80	12" SCH 80	28	80	0.687	2198
	EC-12-110	12" SCH 80	28	110	0.687	2198
HECP-12-28	EC-12-130	12" SCH 80	28	130	0.687	2198
	EC-12-80	12" SCH 80	32	80	0.687	2552
	EC-12-110	12" SCH 80	32	110	0.687	2552
HECP-12-32	EC-12-130	12" SCH 80	32	130	0.687	2552
	EC-12-80	12" SCH 80	36	80	0.687	2906
HECP-12-36	EC-12-110	12" SCH 80	36	110	0.687	2906
	EC-12-130	12" SCH 80	36	130	0.687	2906
	EC-12-130	12" SCH 80	36	130	0.687	2906
HECP-12-40	EC-12-80	12" SCH 80	40	80	0.687	3260
	EC-12-110	12" SCH 80	40	110	0.687	3260
	EC-12-130	12" SCH 80	40	120	0.687	3260

*1 US Ton = 2,000 lbs.



WARNING

DO NOT EXCEED CAPACITY!

See the SAFETY GUIDELINES section before using these products. Pages 92–94.

SPREADER BEAMS

Custom Application Form



For pricing information: Fax completed form & contact info to 717-665-2861 or email Customer Service at customerservice@harringtonhoists.com

LOAD INFORMATION:

Describe the material you are planning to lift: _____

Spreader Beam Stand Required: Yes No

Total Number of Lifting Points: _____ Spacing Between Points _____

Is The CG (center of gravity) Of The Load Between Outer Lifting Points:
 Yes No If No, Describe CG Location _____

Rigging Type Used To Attach To Load: Swivel Hooks Shackles
 Slings (specific type) _____ Other (specific type) _____

Rigging Type Used To Attach To Crane Hook: Chain Wire Rope
Desired Rigging Angle (45 degree recommended): _____

Load Dimensions:

	Min (in)	Max (in)
Height	_____	_____
Width	_____	_____
Length	_____	_____
Weight	_____	_____

CRANE SPECIFICATIONS:

Distance Between Top Of The Load To The Crane Hook High Position(s): _____

Capacity Of The Crane(s): _____

Required Duty Cycle Of The Spreader Beam: Lifts Per Hour _____ Lifts Per Day _____

Crane Classification(s): A B C D E F

CRANE HOOK SPECIFICATIONS (Inches):

A: _____ B: _____ C: _____ D: _____ E: _____ F: _____ G: _____ H: _____

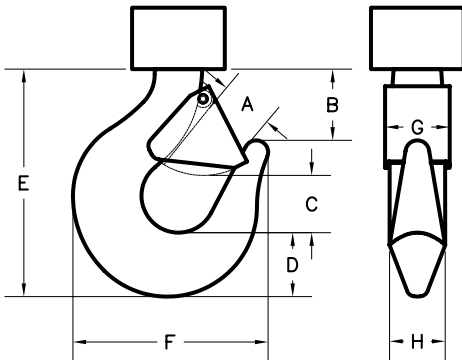

Please provide pertinent application information not supplied above (extreme product or operating temperature, extreme environmental conditions such as temperature or moisture, space or headroom restrictions, additional specifications):

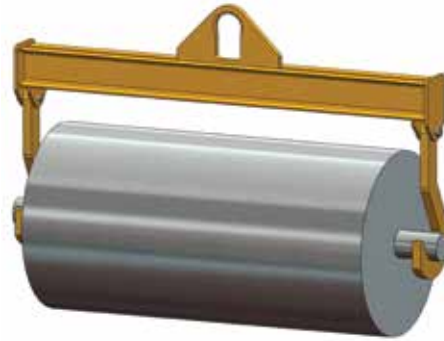

HRLB

ROLL LIFTING BEAM..... Page 44

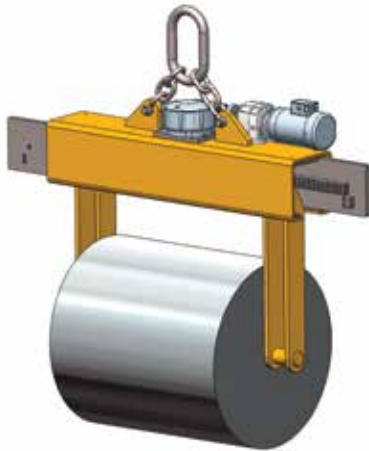

HMRL

MOTORIZED ROLL LIFTER..... Page 45

HRGT

ROLL GRIPPING TONGS..... Page 46

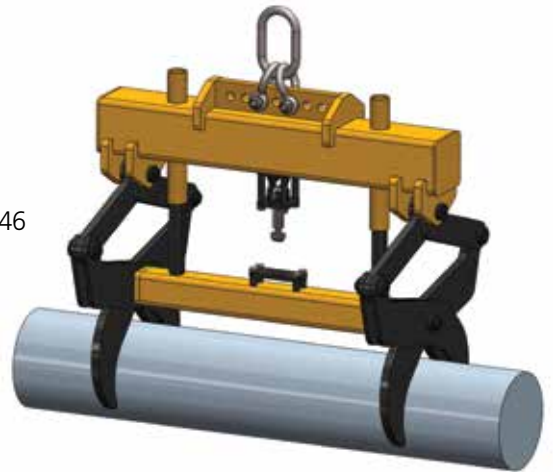

HRLCH

ROLL LIFTING C-HOOK..... Page 47

HRLB ROLL LIFTING BEAM

FEATURES

- This style of lifting beam is designed to easily lift and position rolls by the mandrel/shaft (when it is through the center of the roll) with plate or bent bar J-hooks.
- It can be utilized where headroom is limited and comes with a pair of fixed or pivoting J-hooks.
- Engineered and manufactured to ASME B30.20 & BTH-1 Design Category B Service Class 2.
- 100% of ALL roll lifters are Proof-Tested to 125% capacity and certificates supplied at No Additional Charge.
- Made in USA.

OPTIONS

- Manual or motorized beam rotation
- Adjustable spread
- Higher capacities
- Additional lengths
- Low headroom bail
- Dual bail designed for two hoists
- Spreader beam design with top rigging
- Additional hooks
- Hook linings (bronze/brass, urethane, brake lining)
- Beam stand

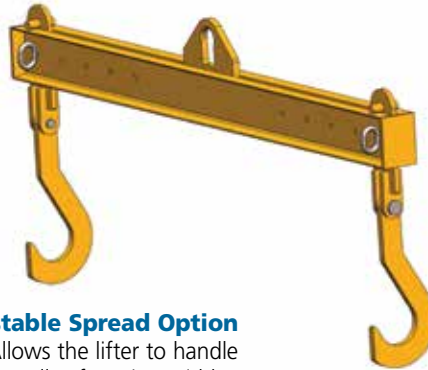
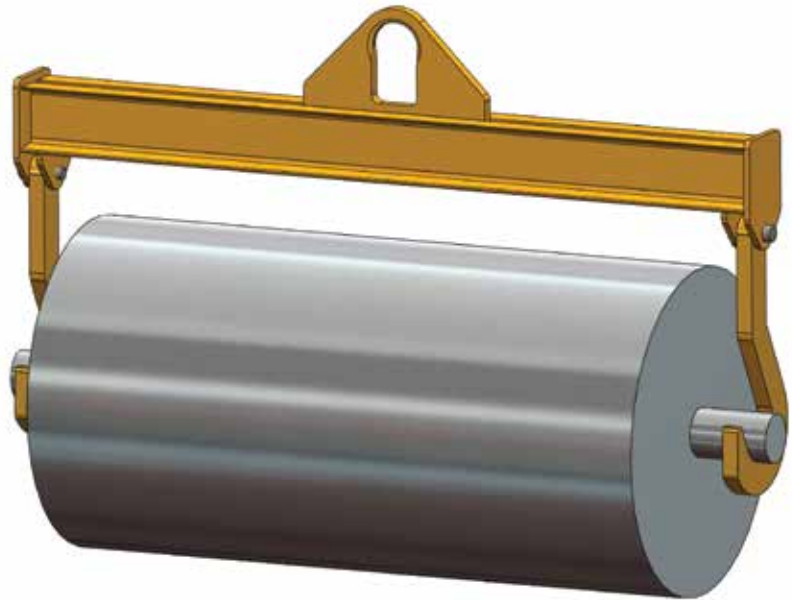

Adjustable Spread Option

Allows the lifter to handle rolls of varying widths.



Hook Lining Option

Utilizes bronze, brass, urethane, or brake linings to provide additional protection to the mandrel or shaft.



Dual Bail Option

Utilizes multiple hoists to add stability to the lift.

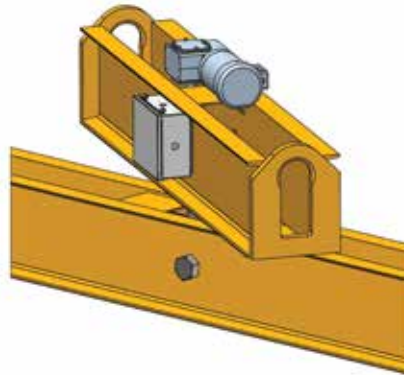

Motorized Rotation Option

Provides the option for remote positioning of the load.



Spreader Beam Design Option

Provides greater stability when headroom is not limited.

HMRL MOTORIZED ROLL LIFTER

FEATURES

- This style of lifter is designed to easily lift and position rolls by placing the lifting pins securely through the I.D. of the roll.
- Designed to meet your specific roll lifting requirements.
- Utilizes a sling style bail that adds stability and provides for ease of maintenance on the gearbox and shaft assembly.
- Can be utilized for a variety of roll widths where aisle clearance is limited.
- Manual chain wheel operation is available.
- Engineered and manufactured to ASME B30.20 & BTH-1 Design Category B Service Class 2.
- 100% of ALL roll lifters are Proof-Tested to 125% capacity and certificates supplied at No Additional Charge.
- Made in USA.

OPTIONS

- Parking and/or maintenance stands available

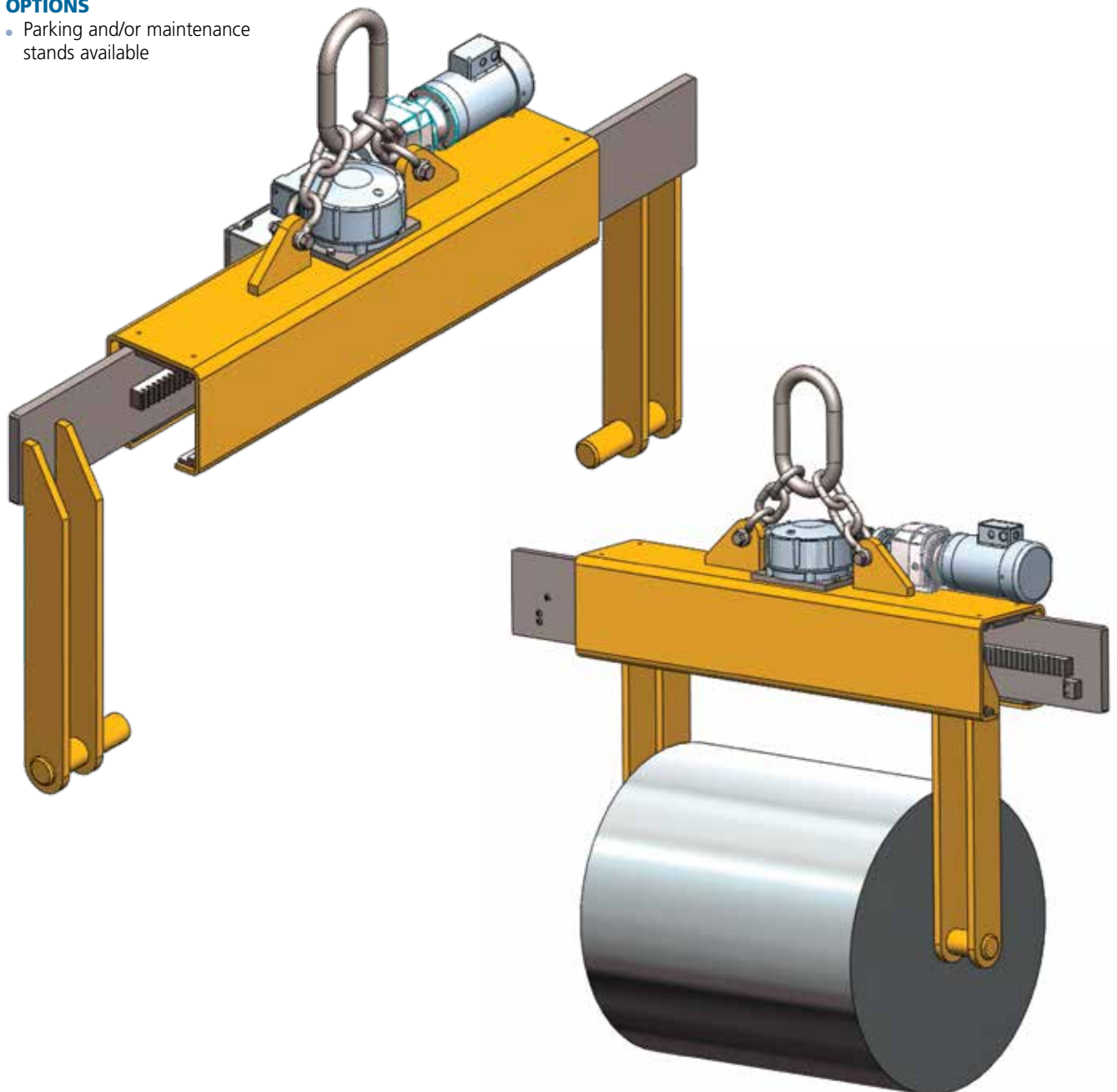

DO NOT EXCEED CAPACITY!
See the SAFETY GUIDELINES section before using these products. Pages 92–94.

HRGT ROLL GRIPPING TONGS

FEATURES

- This style of lifter is designed to easily lift and position rolls by gripping the outer diameter of the roll.
- Designed to meet your specific roll lifting requirements.
- Can be utilized for a variety of roll widths where aisle clearance is limited.
- Auto-latching mechanism supplied for easy one-person operation.
- Protective linings are available to minimize roll damage.
- Engineered and manufactured to ASME B30.20 & BTH-1 Design Category B Service Class 2.
- 100% of ALL roll gripping Tongs are Proof-Tested to 125% capacity and certificates supplied at No Additional Charge.
- Made in USA.

OPTIONS

- Parking and/or maintenance stands available

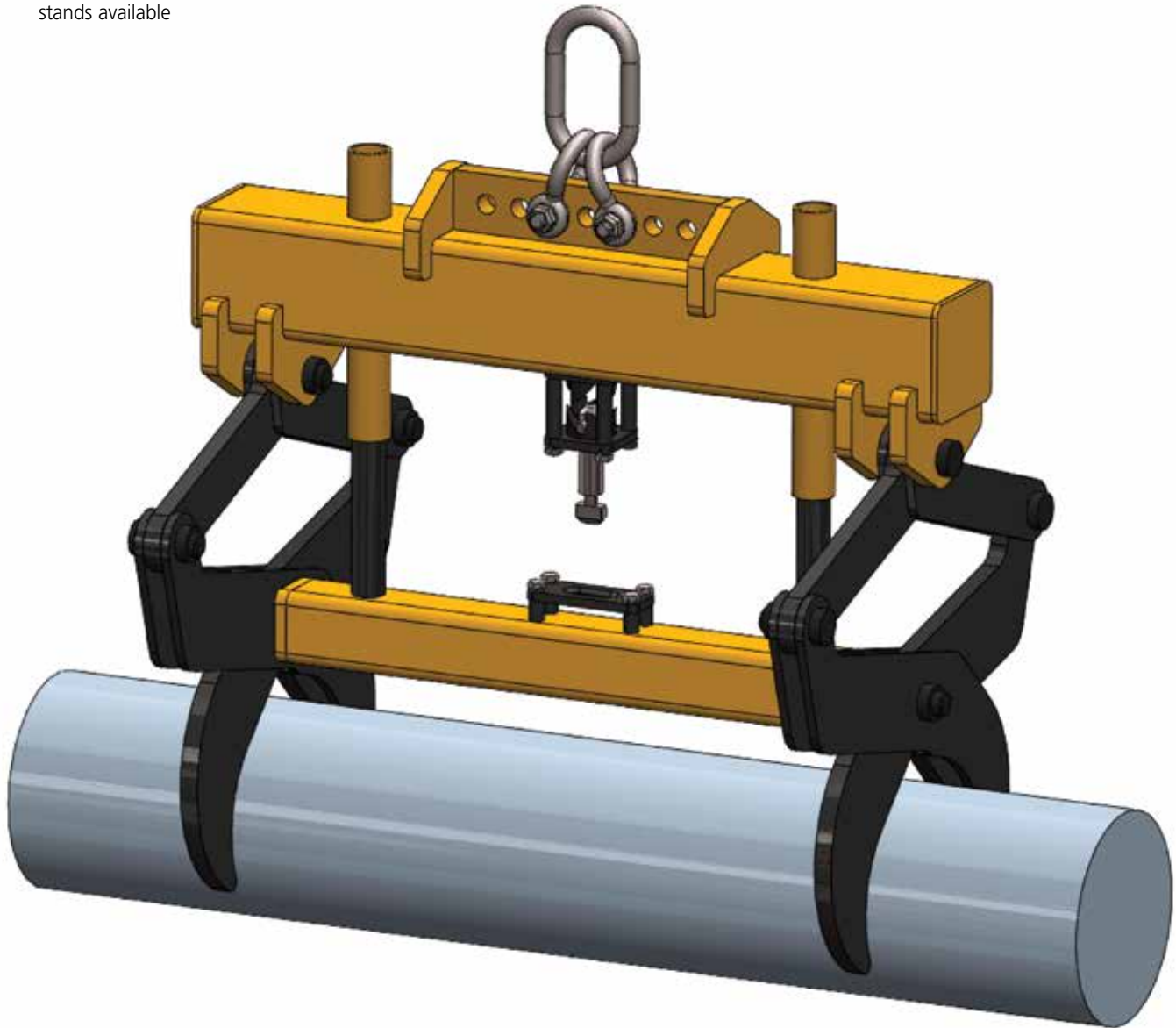

HRLCH ROLL LIFTING C-HOOK

FEATURES

- This style of lifter is designed to easily lift and position rolls by placing the lifting arm securely through the I.D. of the roll.
- Supplied standard with lifter guide handle.
- Engineered and manufactured to ASME B30.20 & BTH-1 Design Category B Service Class 2.
- 100% of ALL roll lifters are Proof-Tested to 125% capacity and certificates supplied at No Additional Charge.
- Made in USA.

OPTIONS

- Higher capacities
- Additional lengths
- Larger throat opening
- Protective padding
- Parking stands

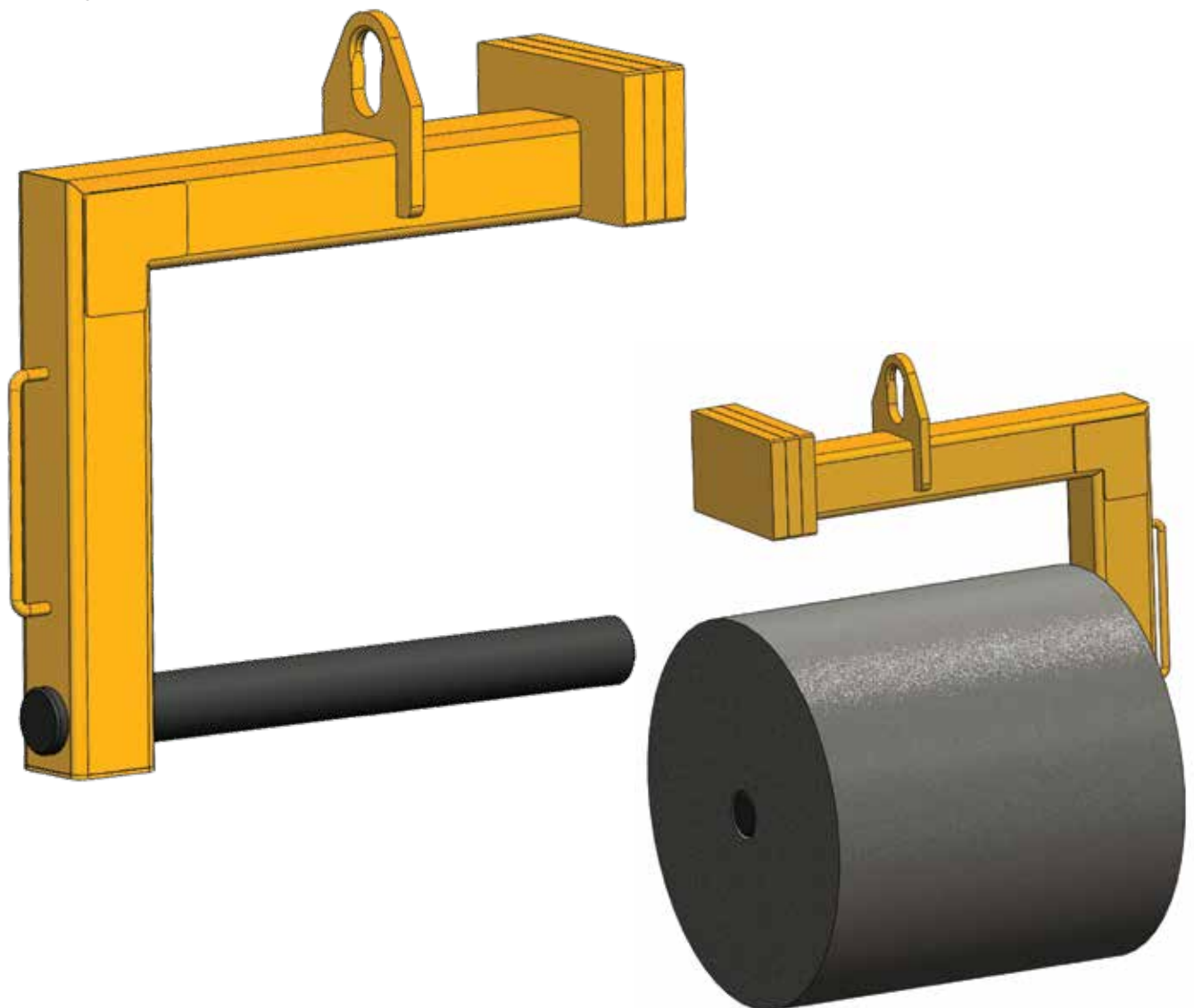

WARNING

DO NOT EXCEED CAPACITY!
See the SAFETY GUIDELINES section before using these products. Pages 92–94.

ROLL LIFTER

Custom Application Form



For pricing information: Fax completed form & contact info to 717-665-2861 or email Customer Service at customerservice@harringtonhoists.com

LOAD INFORMATION:

Describe the material you are planning to lift: _____

Roll Lifter Stand Required: Yes No

Is The CG (center of gravity) Of The Load Between Outer Lifting Points:
 Yes No If No, Describe CG Location _____

Will Roll Be Lifted With A Mandrel Or Shaft: Yes No
If Yes: Mandrel/Shaft Dimensions (inches)
Min Diameter _____ Length _____ Max Diameter _____ Length _____

Will Mandrel/Shaft Turn During Lift: Yes No

Mandrel/Shaft Hook Type: Plate Bent Bar Pivoting Fixed

Do Hooks Require Protective Lining: Yes No
If Yes: Brass Bronze Urethane Brake Other (specify) _____
If No, Roll I.D. Dimensions (inches): Min Diameter _____ Length _____ Max Diameter _____ Length _____

Bundled Load Dimensions:

	Min (in)	Max (in)
O.D.		
I.D.		
Length		
Weight		

CRANE SPECIFICATIONS:

Crane Configuration: Single Double

Distance Between Top Of The Load To The Crane Hook High Position(s): _____

Capacity Of The Crane(s): _____ Distance Between Cranes (if applicable): _____
Required Duty Cycle Of The Roll Lifter: Lifts Per Hour _____ Lifts Per Day _____

Crane Classification(s): A B C D E F

MOTORIZED ROLL LIFTER APPLICATION:

Operation: Manual Motorized: AC DC Voltage _____ Phase _____ Cycle _____

Controls Required: Yes No If Yes: Specify Type _____ Furnish Loose Mounted On Lifter

CRANE HOOK SPECIFICATIONS (Inches) :

A: _____ B: _____ C: _____ D: _____ E: _____ F: _____ G: _____ H: _____

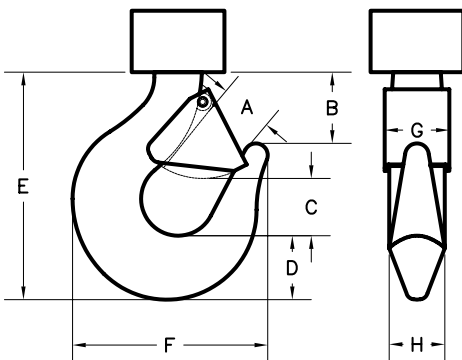

Please provide pertinent application information not supplied above (extreme product or operating temperature, extreme environmental conditions such as temperature or moisture, space or headroom restrictions, additional specifications):

HCLNC

COIL LIFTER NARROW COILPage 50



HCL

COIL LIFTER.....Page 51



HCLCS

COIL LIFTER CLOSE STACKING.....Page 52



HCLSC

COIL LIFTER SLIT COIL.....Page 53

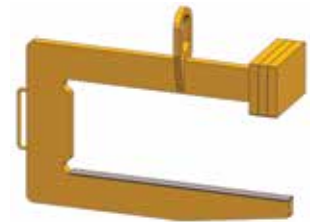

HCLV

COIL LIFTER VERTICALPage 54



HCLVW

COIL LIFTER VERTICAL WIDEPage 55

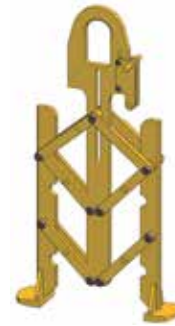

HCGV

COIL GRAB VERTICAL.....Page 56



HCLT

COIL LIFTER TELESCOPIC TWO-SIDEDPage 57

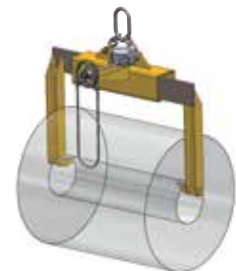

HNAACL

NARROW ARM COIL LIFTERPage 58





HCLNC COIL LIFTER NARROW COIL

FEATURES

- This style of lifter is designed to easily lift and position narrow coils by placing the lifting arm securely through the I.D. of the coil.
- Supplied with standard lifter guide handle and radius on lifting arm to minimize coil damage.
- Engineered and manufactured to ASME B30.20 & BTH-1 Design Category B Service Class 2.
- 100% of ALL coil lifters are Proof-Tested to 125% capacity and certificates supplied at No Additional Charge.
- Made in USA.

OPTIONS

- Higher capacities
- Additional lengths
- Larger throat opening
- Protective padding
- Coil retainer cap
- Parking stands

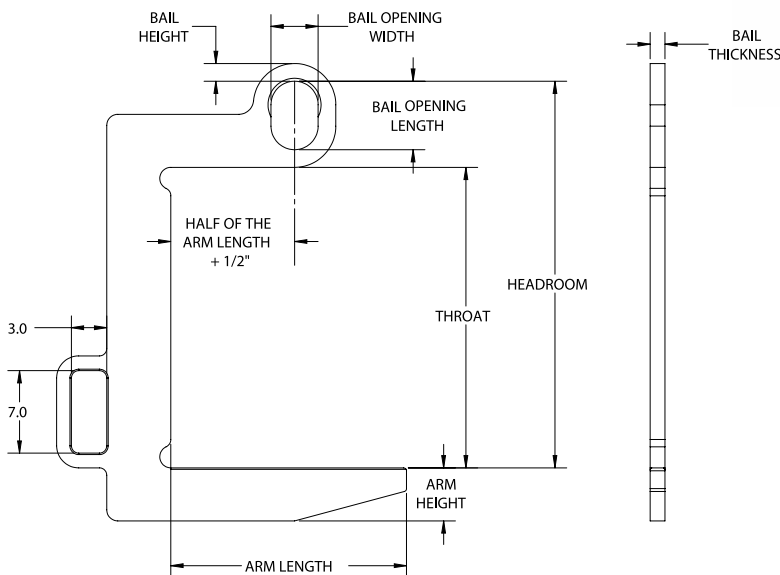
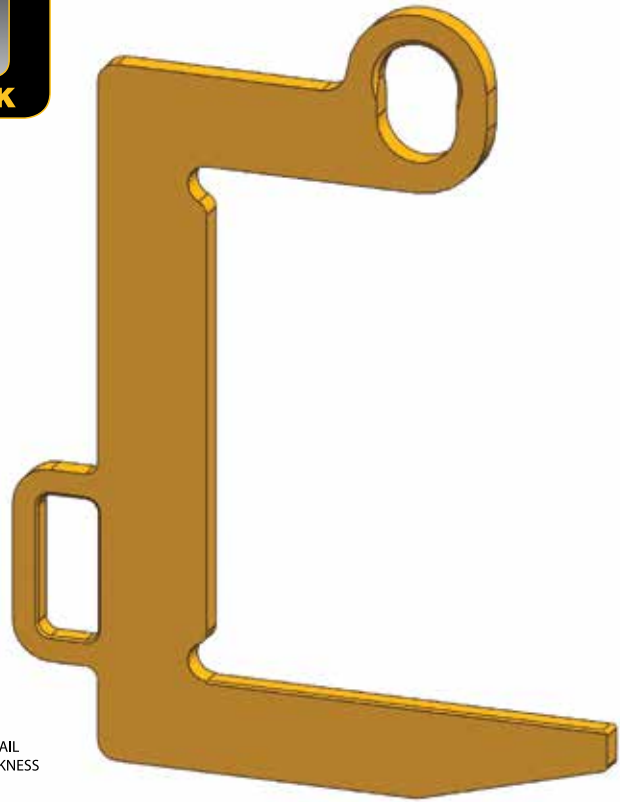

Model #	Capacity (US Tons)*	Dimensions (Inches)									Weight (Lbs.)
		Coil Width Max	Headroom	Lift Arm Length	Lift Arm Height	Throat Opening Height	Bail Height	Bail Opening Width	Bail Opening Height	Bail Thickness	
HCLNC-1/2-8	1/2	8	18.6	8	2.25	14.5	0.75	2	3.25	0.5	13
HCLNC-1/2-12	1/2	12	18.6	12	2.25	14.5	0.75	2	3.25	0.5	14
HCLNC-1-8	1	8	21.6	8	2.25	17.5	0.81	2	3.25	0.5	15
HCLNC-1-16	1	16	21.6	16	3	17.5	0.81	2	3.25	0.5	22
HCLNC-2-8	2	8	24.5	8	2.5	19.5	1	2.63	4	0.75	27
HCLNC-2-16	2	16	24.5	16	3.25	19.5	1	2.63	4	0.75	41
HCLNC-3.5-12	3.5	12	28.2	12	3.25	21.5	1.19	3.63	5.5	1	57
HCLNC-3.5-16	3.5	16	28.2	16	3.75	21.5	1.19	3.63	5.5	1	69
HCLNC-5-16	5	16	33	16	4	25.5	1.5	4	6	1.25	105
HCLNC-5-20	5	20	33	20	4.5	25.5	1.5	4	6	1.25	121

*1 US Ton = 2,000 lbs.



HCL COIL LIFTER

FEATURES

- This style of heavy duty lifter is designed to easily lift and position large heavy coils by placing the lifting arm securely through the I.D. of the coil.
- Supplied with standard lifter guide handle and curved saddle on lifting arm to minimize coil damage, optional padding is available for additional coil protection.
- Counterbalanced to hang level when not loaded.
- Engineered and manufactured to ASME B30.20 & BTH-1 Design Category B Service Class 2.
- 100% of ALL coil lifters are Proof-Tested to 125% capacity and certificates supplied at No Additional Charge.
- Made in USA.

OPTIONS

- Higher capacities
- Additional lengths
- Larger throat opening
- Protective padding
- Parking stands

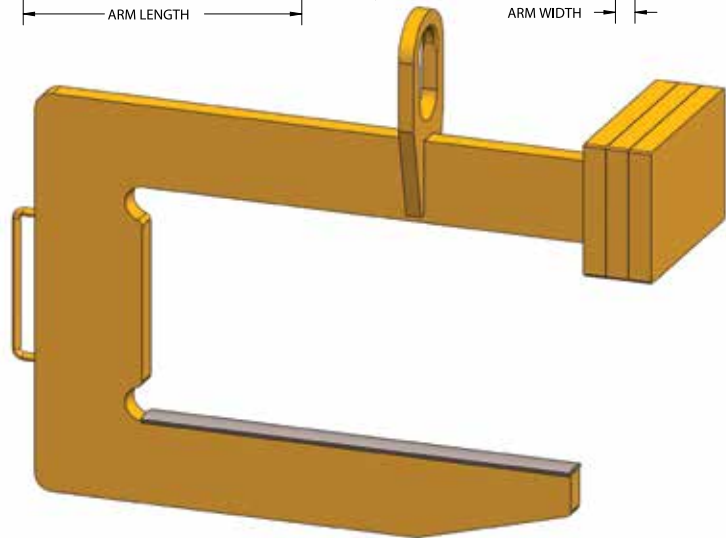
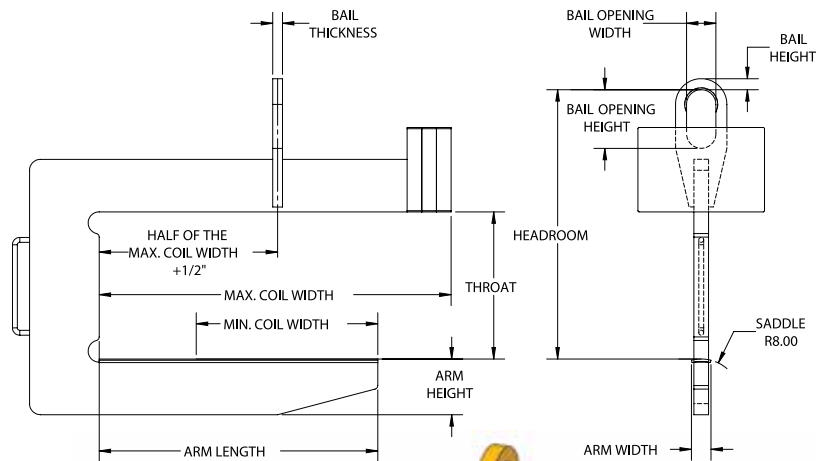

Model #	Capacity (US Tons)*	Dimensions (Inches)										Weight (Lbs.)
		Coil Width Max/Min	Headroom	Lift Arm Length	Lift Arm Height	Lift Arm Width	Throat Opening Height	Bail Height	Bail Opening Width	Bail Opening Height	Bail Thickness	
HCL-5-36	5	36/24	38	30	6.25	4	24	1.5	4	7	1.25	500
HCL-5-48	5	48/30	38	39	6.25	4	24	1.5	4	7	1.25	730
HCL-5-60	5	60/36	38.8	48	7	4	24	1.5	4	7	1.25	885
HCL-7.5-36	7.5	36/24	38.3	30	6.5	4	24	1.5	4	7	1.5	725
HCL-7.5-48	7.5	48/30	39	39	7.25	4	24	1.5	4	7	1.5	875
HCL-7.5-60	7.5	60/36	39.8	48	8	4	24	1.5	4	7	1.5	1060
HCL-10-48	10	48/30	42.5	39	8.25	4	24	2	5	9	1.75	1060
HCL-10-60	10	60/36	42.5	48	8.25	4	24	2	5	9	1.75	1425
HCL-10-72	10	72/42	43.3	57	9	4	24	2	5	9	1.75	1670
HCL-15-48	15	48/30	49.3	39	9	4	30	2	5	9	1.75	1615
HCL-15-60	15	60/36	50.3	48	10	4	30	2	5	9	1.75	1925
HCL-15-72	15	72/42	51	57	10.75	4	30	2	5	9	1.75	2220
HCL-20-60	20	60/36	54	48	10.5	4	30	2.25	6	12	2	2520
HCL-20-72	20	72/42	55	57	11.5	4	30	2.25	6	12	2	2950
HCL-25-60	25	60/36	61.5	48	11.75	4	34	2.5	6	14	2.25	3060
HCL-25-72	25	72/42	62.5	57	12.75	4	34	2.5	6	14	2.25	3525
HCL-30-60	30	60/36	62.75	48	12.75	4	34	2.75	6	14	2.5	3425
HCL-30-72	30	72/42	62	57	12	5	34	2.75	6	14	2.5	4525
HCL-40-72	40	72/42	72.3	57	13.75	5	38	3.25	7	18	3	5730
HCL-50-84	50	84/48	77.5	66	16.5	5	40	3.75	7	18	3	7550

*1 US Ton = 2,000 lbs.



DO NOT EXCEED CAPACITY!
See the SAFETY GUIDELINES section before using these products. Pages 92–94.

HCLCS COIL LIFTER CLOSE STACKING

FEATURES

- This style of heavy duty lifter is designed with a recessed counterweight to allow for close coil stacking that maximizes floor space.
- Designed to easily lift and position large heavy coils by placing the lifting arm securely through the I.D. of the coil.
- Supplied with standard lifter guide handle and curved saddle on lifting arm to minimize coil damage, optional padding is available for additional coil protection.
- Counterbalanced to hang level when not loaded.
- Engineered and manufactured to ASME B30.20 & BTH-1 Design Category B Service Class 2.
- 100% of ALL coil lifters are Proof-Tested to 125% capacity and certificates supplied at No Additional Charge.
- Made in USA.

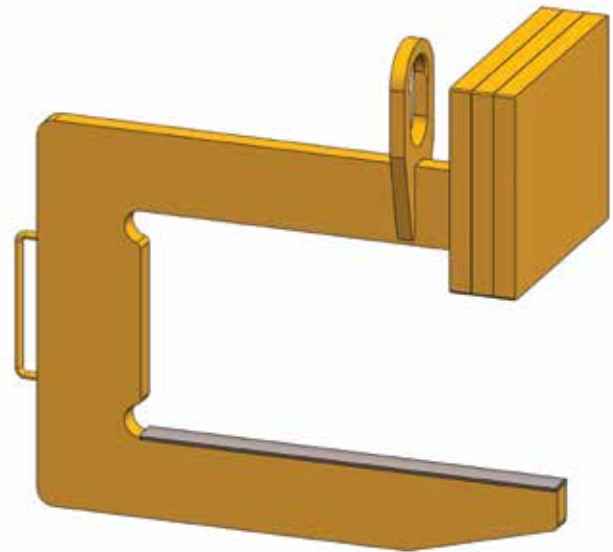

COIL LIFTERS

OPTIONS

- Higher capacities
- Additional lengths
- Larger throat opening
- Protective padding
- Parking stands

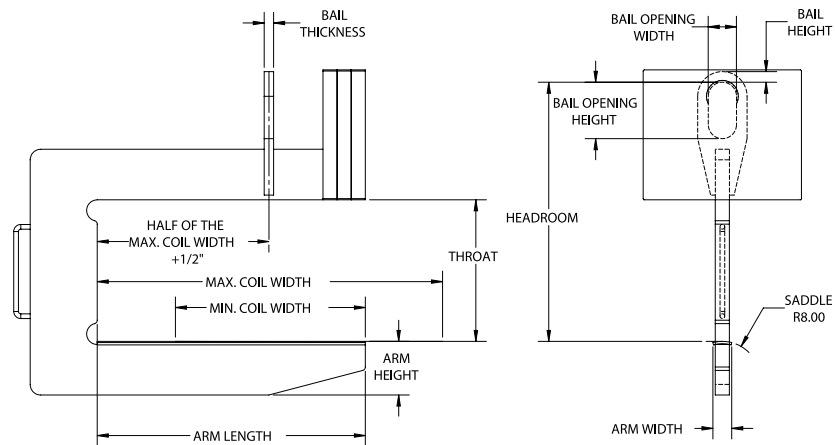

Model #	Capacity (US Tons)*	Dimensions (Inches)										Weight (Lbs.)
		Coil Width Max/Min	Head-room	Lift Arm Length	Lift Arm Height	Lift Arm Width	Throat Opening Height	Bail Height	Bail Opening Width	Bail Opening Height	Bail Thickness	
HCLCS-5-36	5	36/24	38	30	6.25	4	24	1.5	4	7	1.25	633
HCLCS-5-48	5	48/30	38	39	6.25	4	24	1.5	4	7	1.25	950
HCLCS-5-60	5	60/36	38.8	48	7	4	24	1.5	4	7	1.25	1150
HCLCS-7.5-36	7.5	36/24	38.3	30	6.5	4	24	1.5	4	7	1.5	950
HCLCS-7.5-48	7.5	48/30	39	39	7.25	4	24	1.5	4	7	1.5	1150
HCLCS-7.5-60	7.5	60/36	39.8	48	8	4	24	1.5	4	7	1.5	1385
HCLCS-10-48	10	48/30	42.5	39	8.25	4	24	2	5	9	1.75	1390
HCLCS-10-60	10	60/36	42.5	48	8.25	4	24	2	5	9	1.75	1905
HCLCS-10-72	10	72/42	43.3	57	9	4	24	2	5	9	1.75	2210
HCLCS-15-48	15	48/30	49.3	39	9	4	30	2	5	9	1.75	2210
HCLCS-15-60	15	60/36	50.3	48	10	4	30	2	5	9	1.75	2610
HCLCS-15-72	15	72/42	51	57	10.75	4	30	2	5	9	1.75	2990
HCLCS-20-60	20	60/36	54	48	10.5	4	30	2.25	6	12	2	3490
HCLCS-20-72	20	72/42	55	57	11.5	4	30	2.25	6	12	2	4045
HCLCS-25-60†	25	60/36	61.5	48	11.75	4	34	2.5	6	14	2.25	3620
HCLCS-25-72†	25	72/42	62.5	57	12.75	4	34	2.5	6	14	2.25	4250
HCLCS-30-60†	30	60/36	62.75	48	12.75	4	34	2.75	6	14	2.5	4060
HCLCS-30-72†	30	72/42	62	57	12	5	34	2.75	6	14	2.5	5360
HCLCS-40-72†	40	72/42	72.3	57	13.75	5	38	3.25	7	18	3	6805

*1 US Ton = 2,000 lbs.

†Counterweight extends beyond the arm by one-half of the counterweight width (thickness).



HCLSC COIL LIFTER SLIT COIL

FEATURES

- This style of heavy duty lifter is designed to handle multiple slit coils maximizing efficiency.
- Designed to easily lift and position large heavy slit coils by placing the lifting arm securely through the I.D. of the coil.
- Supplied with standard lifter guide handle and curved saddle on lifting arm to minimize coil damage, optional padding is available for additional coil protection.
- Counterbalanced to hang level when not loaded.
- Engineered and manufactured to ASME B30.20 & BTH-1 Design Category B Service Class 2.
- 100% of ALL coil lifters are Proof-Tested to 125% capacity and certificates supplied at No Additional Charge.
- Made in USA.

OPTIONS

- Higher capacities
- Additional lengths
- Larger throat opening
- Protective padding
- Parking stands

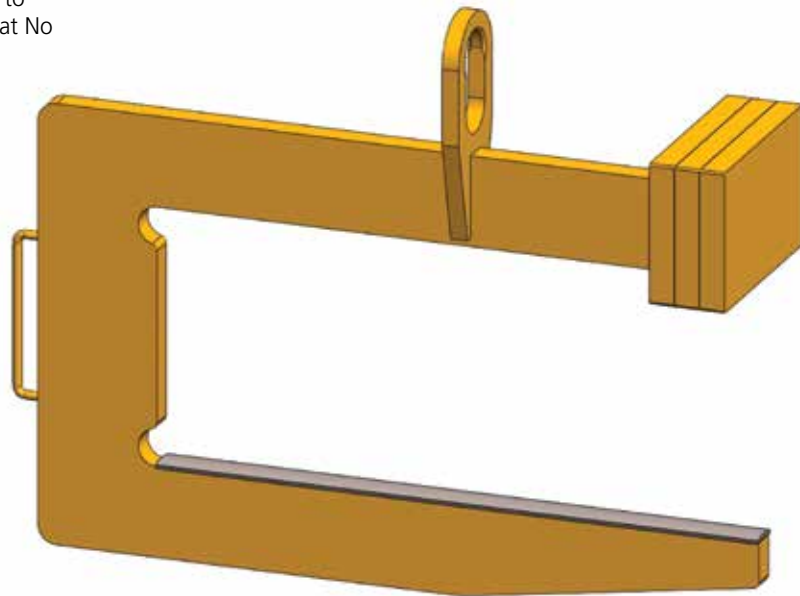
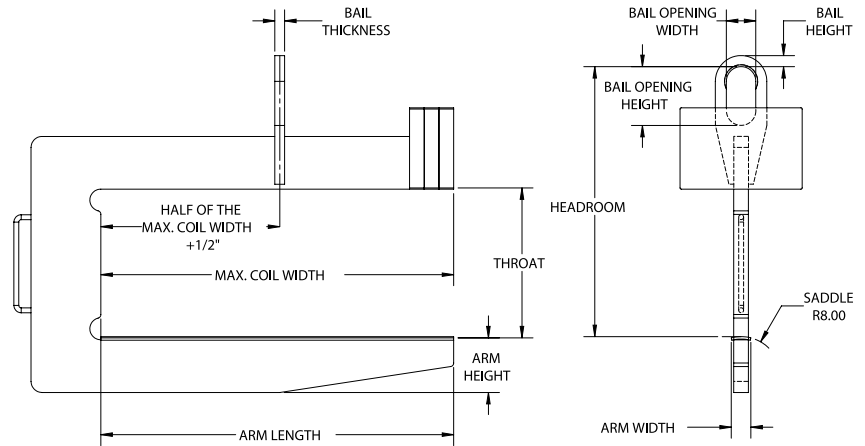

Model #	Capacity (US Tons)*	Dimensions (Inches)										Weight (Lbs.)
		Coil Width Max	Head-room	Lift Arm Length	Lift Arm Height	Lift Arm Width	Throat Opening Height	Bail Height	Bail Opening Width	Bail Opening Height	Bail Thickness	
HCLSC-5-36	5	36	38	36	6.25	4	24	1.5	4	7	1.25	510
HCLSC-5-48	5	48	38	48	6.25	4	24	1.5	4	7	1.25	740
HCLSC-5-60	5	60	38.8	60	7	4	24	1.5	4	7	1.25	905
HCLSC-7.5-36	7.5	36	38.3	36	6.5	4	24	1.5	4	7	1.5	730
HCLSC-7.5-48	7.5	48	39	48	7.25	4	24	1.5	4	7	1.5	890
HCLSC-7.5-60	7.5	60	39.8	60	8	4	24	1.5	4	7	1.5	1080
HCLSC-10-48	10	48	42.5	48	8.25	4	24	2	5	9	1.75	1070
HCLSC-10-60	10	60	42.5	60	8.25	4	24	2	5	9	1.75	1450
HCLSC-10-72	10	72	43.3	72	9	4	24	2	5	9	1.75	1700
HCLSC-15-48	15	48	49.3	48	9	4	30	2	5	9	1.75	1630
HCLSC-15-60	15	60	50.3	60	10	4	30	2	5	9	1.75	1945
HCLSC-15-72	15	72	51	72	10.75	4	30	2	5	9	1.75	2255
HCLSC-20-60	20	60	54	60	10.5	4	30	2.75	6	12	2	2540
HCLSC-20-72	20	72	55	72	11.5	4	30	2.75	6	12	2	2985
HCLSC-25-60	25	60	61.5	60	11.75	4	34	3.25	6	14	2.5	3085
HCLSC-25-72	25	72	62.5	72	12.75	4	34	3.25	6	14	2.5	3560

*1 US Ton = 2,000 lbs.



DO NOT EXCEED CAPACITY!
See the SAFETY GUIDELINES section before using these products. Pages 92–94.

HCLV COIL LIFTER VERTICAL

FEATURES

- This style of lifter is designed to handle coils that are stacked vertically.
- Supplied with standard leg positioning handle with built in positive locking feature.
- Engineered and manufactured to ASME B30.20 & BTH-1 Design Category B Service Class 2.
- 100% of ALL coil lifters are Proof-Tested to 125% capacity and certificates supplied at No Additional Charge.
- Made in USA.

OPTIONS

- Higher capacities
- Additional lengths
- Protective padding

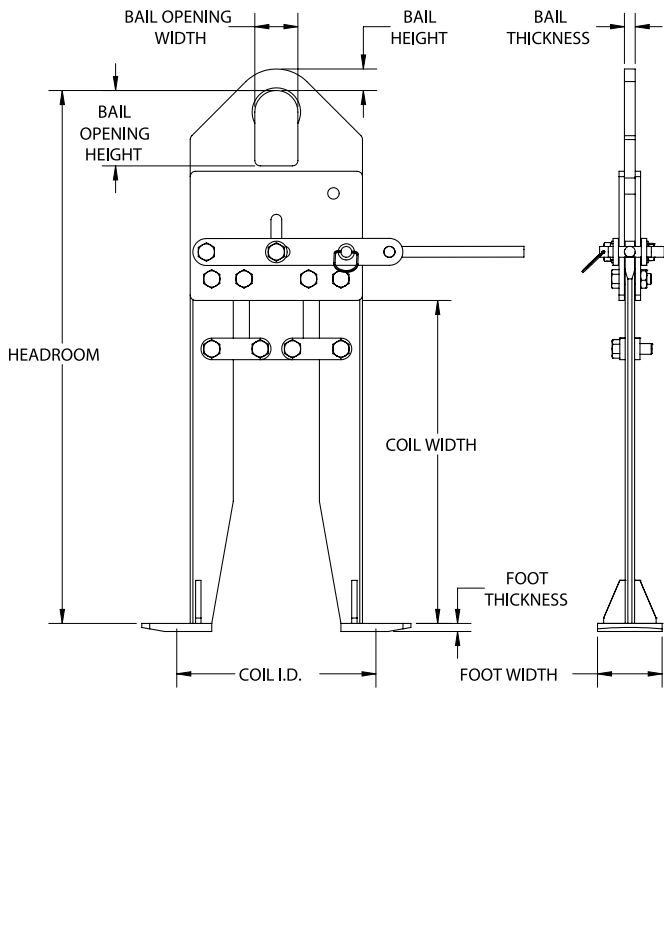
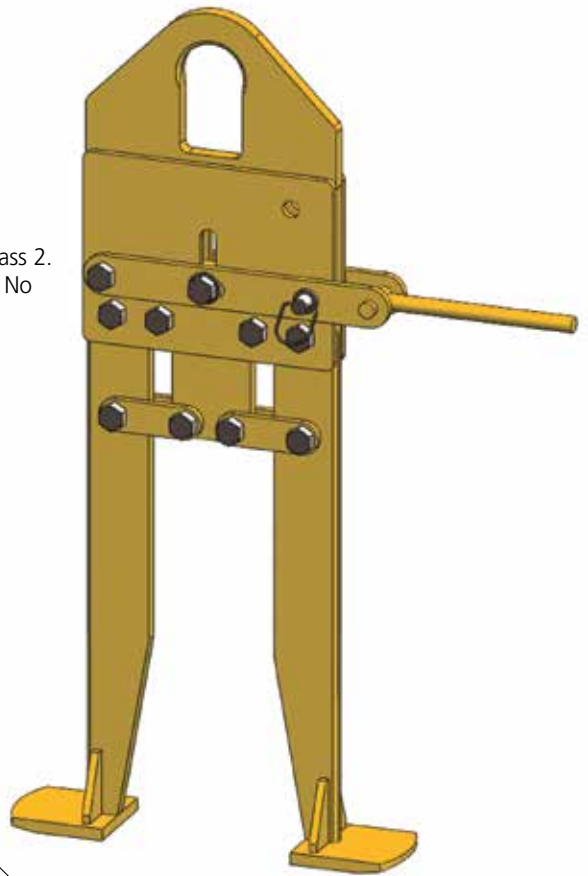

Model #	Capacity (US Tons)*	Dimensions (Inches)										Weight (Lbs.)
		Coil ID Min/Max	Coil Width Max	Head-room	Foot Width	Foot Thickness	Foot Length	Bail Height	Bail Opening Width	Bail Opening Height	Bail Thickness	
HCLV-1/2-20	1/2	16/20	20	36	4	0.75	13	1.25	3	5	0.63	110
HCLV-1.5-20	1.5	16/20	24	36	4	0.75	13	1.5	3	5	0.63	125
HCLV-3-20	3	16/20	24	40	5	0.75	13.5	1.5	3	5	0.75	180
HCLV-5-20	5	16/20	30	49	6	0.75	14.25	2	4	7	1	195

*1 US Ton = 2,000 lbs.



HCLVW COIL LIFTER VERTICAL WIDE

FEATURES

- This style of lifter is designed to handle coils that are stacked vertically.
- Supplied with standard self-adjusting legs that automatically adjust to the I.D. of the coil.
- Engineered and manufactured to ASME B30.20 & BTH-1 Design Category B Service Class 2.
- 100% of ALL coil lifters are Proof-Tested to 125% capacity and certificates supplied at No Additional Charge.
- Made in USA.

OPTIONS

- Higher capacities
- Additional lengths
- Protective padding

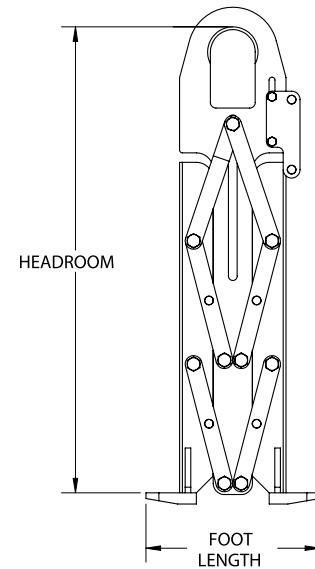
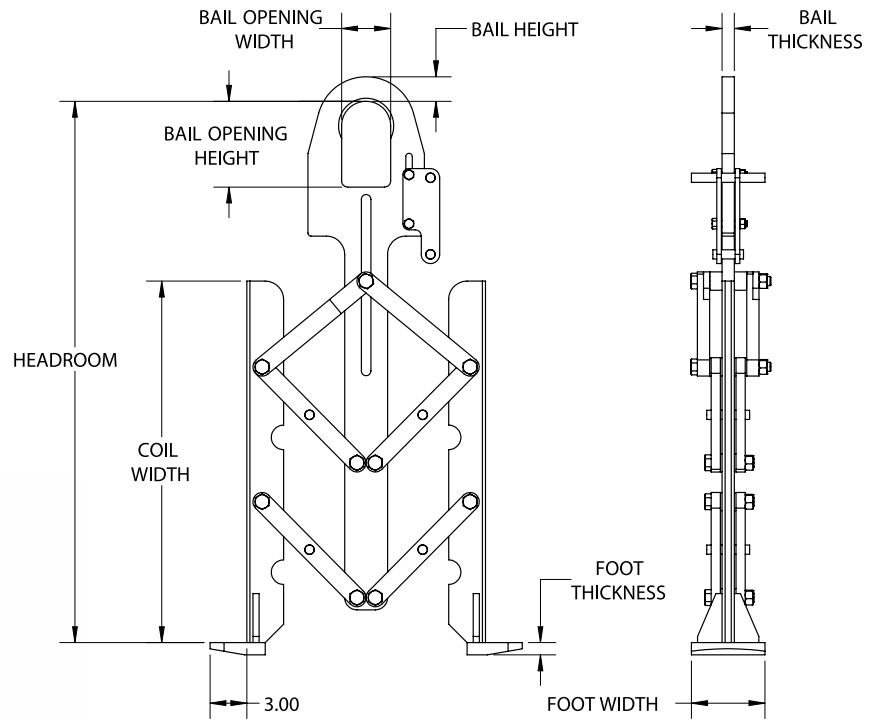
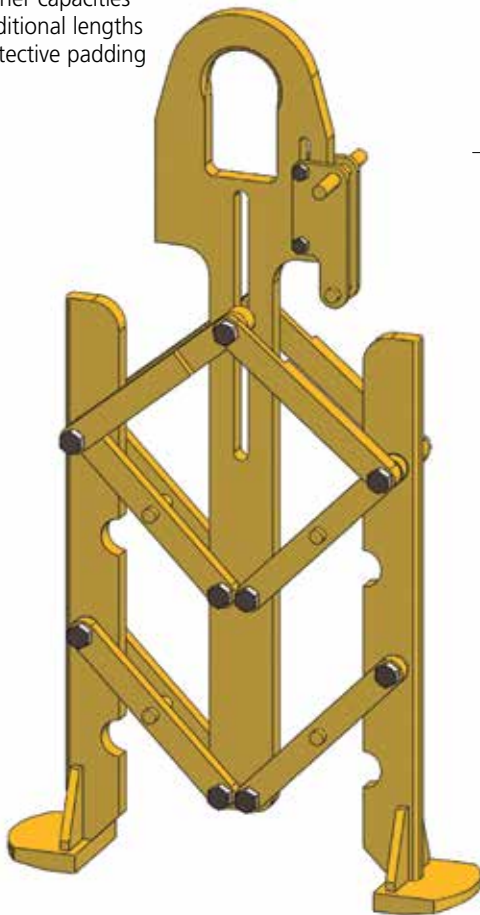

Model #	Capacity (US Tons)*	Dimensions (Inches)											Weight (Lbs.)
		Coil ID Min/Max	Coil Width Max	Headroom		Foot Width	Foot Thickness	Foot Length	Bail Height	Bail Opening Width	Bail Opening Height	Bail Thickness	
				Open	Closed								
HCLVW-1/2-24	1/2	16/24	20	37	32	5	0.5	14.5	1.25	3	5	0.63	90
HCLVW-2.5-24	2.5	16/24	24	45	38.5	5	0.75	15.5	1.5	3	5	0.75	125
HCLVW-5-24	5	16/24	30	48	41.5	6	1	15.5	2	4	7	1	170
HCLVW-7.5-24	7.5	16/24	30	48	41.5	6	1	15.5	2	4	8	1	170

*1 US Ton = 2,000 lbs.



WARNING

DO NOT EXCEED CAPACITY!
See the SAFETY GUIDELINES section before using these products. Pages 92-94.

HCGV COIL GRAB VERTICAL

FEATURES

- This style of lifter is designed to handle coils that are stacked vertically.
- Supplied with manual adjusting legs that adjust to the I.D. of the coil with the standard hand wheel or optional chain wheel.
- Can be supplied with optional motorized leg drive.
- Engineered and manufactured to ASME B30.20 & BTH-1 Design Category B Service Class 2.
- 100% of ALL coil lifters are Proof-Tested to 125% capacity and certificates supplied at No Additional Charge.
- Made in USA.

OPTIONS

- Higher capacities
- Additional lengths
- Protective padding
- Parking stands
- Motorized leg drive

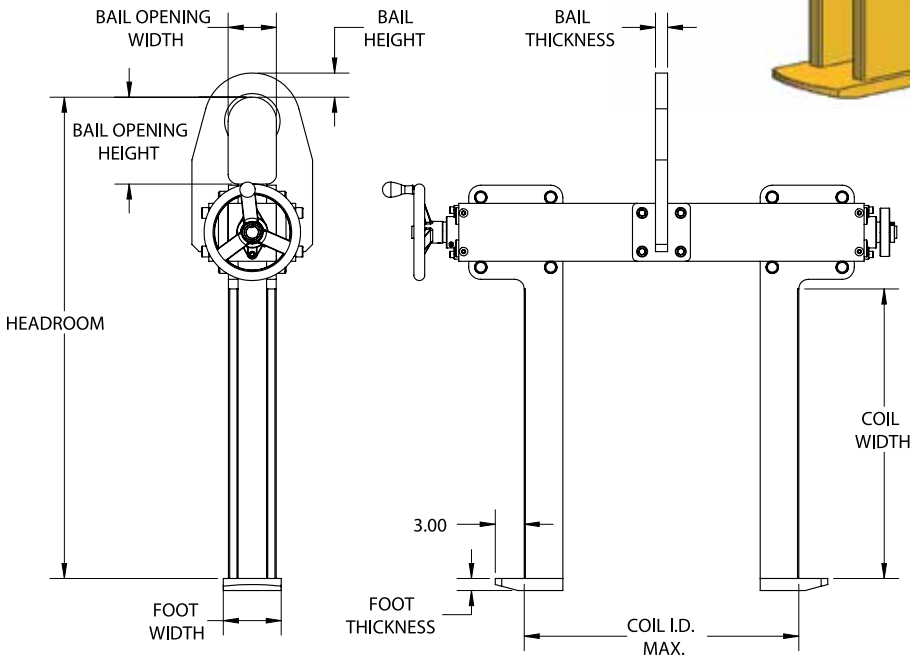
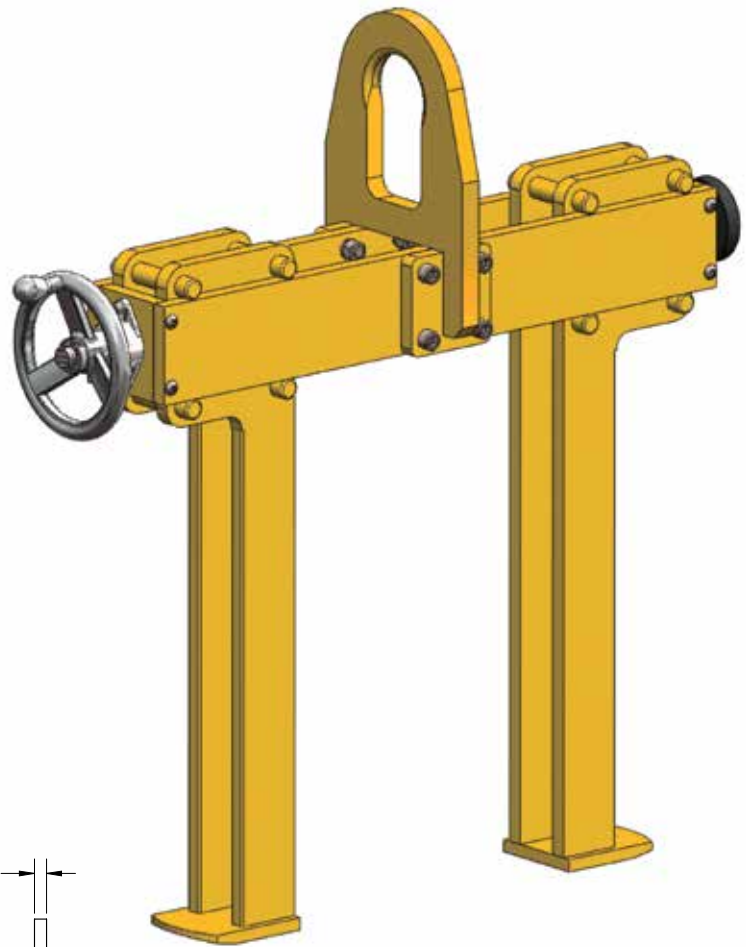

Model #	Capacity (US Tons)*	Coil ID Min/Max	Dimensions (Inches)									Weight (Lbs.)
			Coil Width Max	Head-room	Foot Width	Foot Thickness	Foot Length	Bail Height	Bail Opening Width	Bail Opening Height	Bail Thickness	
HCGV-2.5-24	2.5	16/24	20	36	5	0.75	15.5	1.5	3	5	0.75	275
HCGV-5-24	5	16/24	24	41	6	1	15.5	2	4	7	1	385
HCGV-7.5-24	7.5	16/24	24	42	6	1	15.5	2	4	7	1	468
HCGV-10-24	10	16/24	30	50	6	1.5	15.5	2.5	5	9	1.25	550

*1 US Ton = 2,000 lbs.



HCLT COIL LIFTER TELESCOPIC TWO-SIDED

FEATURES

- This style of lifter is designed to efficiently handle coils with the eye horizontal.
- The manual adjusting legs adjust to the I.D. of the coil with the standard chain wheel or an optional motorized leg drive and require less aisle space for operation.
- The self-locking gear drive prevents the inadvertent opening of the legs and curved foot pad minimizes coil damage.
- Engineered and manufactured to ASME B30.20 & BTH-1 Design Category B Service Class 2.
- 100% of ALL coil lifters are Proof-Tested to 125% capacity and certificates supplied at No Additional Charge.
- Made in USA.

OPTIONS

- Higher capacities
- Additional lengths
- Protective padding
- Parking stands
- Motorized leg drive

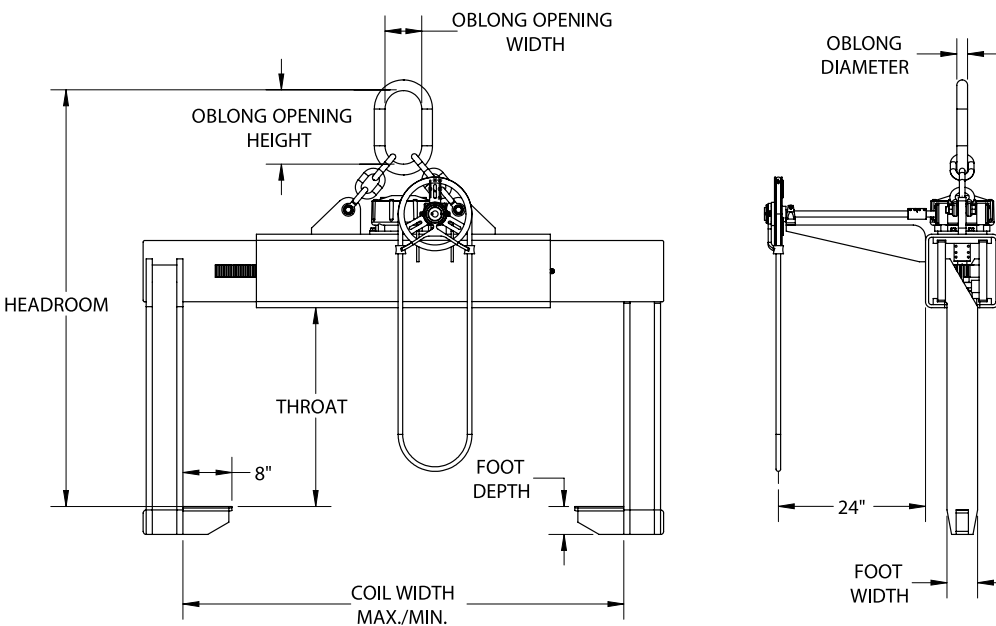
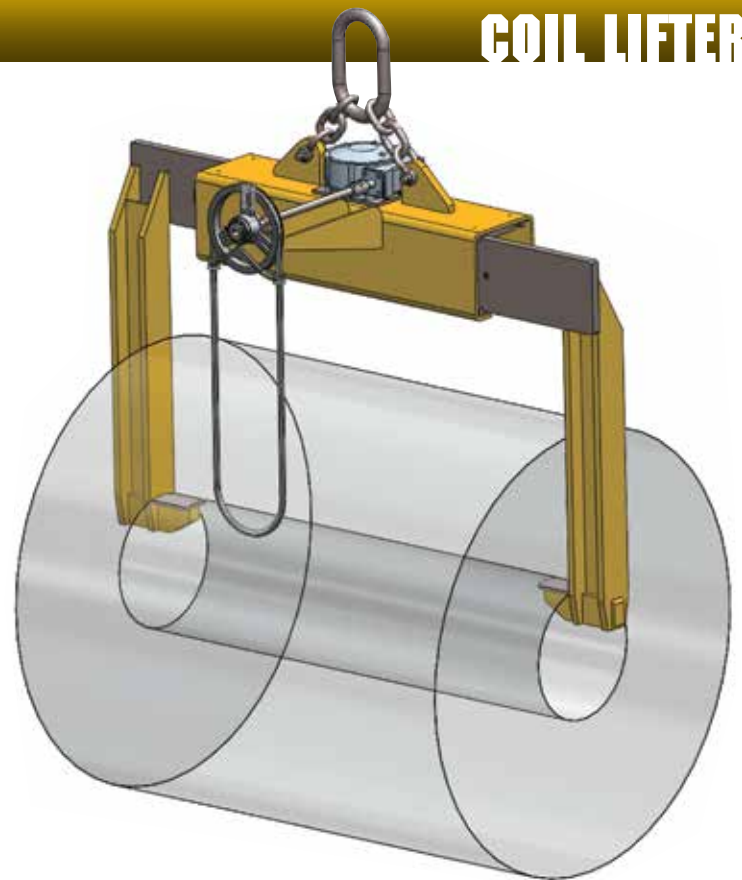

Model #	Capacity (US Tons)*	Dimensions (Inches)								Weight (Lbs.)
		Coil Width Min/Max	Throat Opening Height	Headroom	Foot Width	Foot Thickness	Oblong ML Diameter	Oblong ML Opening Width	Oblong ML Opening Height	
HCLT-5-48	5	16/48	26	51	4	4	1	3.5	7	679
HCLT-5-60	5	20/60	28	53	4	4	1	3.5	7	826
HCLT-10-48	10	16/48	30	62	4	5	1.25	4.38	8.75	1015
HCLT-10-60	10	20/60	32	64	4	5	1.25	4.38	8.75	1134
HCLT-15-60	15	20/60	32	68	4	6	1.5	5.25	10.5	1302
HCLT-15-72	15	24/72	34	70	4	6	1.5	5.25	10.5	1505

*1 US Ton = 2,000 lbs.



DO NOT EXCEED CAPACITY!
See the SAFETY GUIDELINES section before using these products. Pages 92–94.

HNACL NARROW ARM COIL LIFTER

FEATURES

- This style of lifter is designed to economically handle coils with the eye horizontal.
- The manual adjusting legs easily adjust to the I.D. of the coil and require less aisle space for operation.
- Supplied with standard plate style legs with rounded corners to minimize coil damage. (Round bar legs can be supplied as an option).
- Engineered and manufactured to ASME B30.20 & BTH-1 Design Category B Service Class 2.
- 100% of ALL coil lifters are Proof-Tested to 125% capacity and certificates supplied at No Additional Charge.
- Made in USA.

OPTIONS

- Higher capacities
- Additional lengths
- Round bar legs
- Protective padding
- Parking stands

COIL LIFTERS

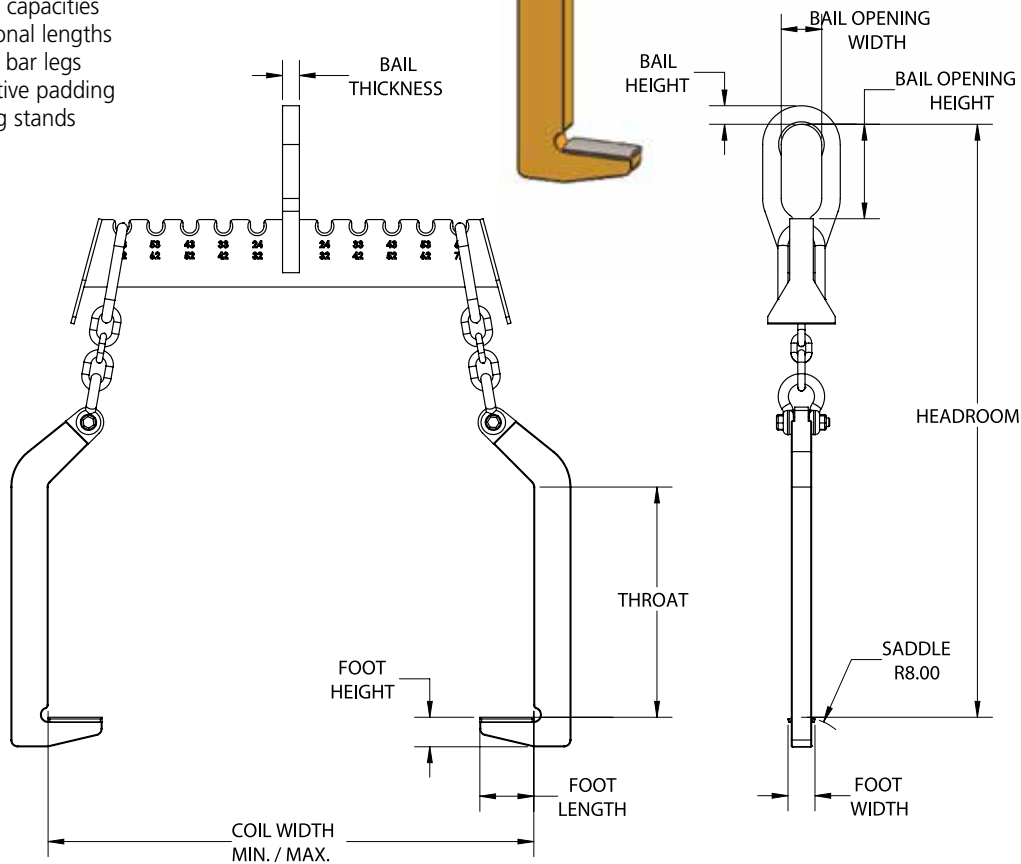
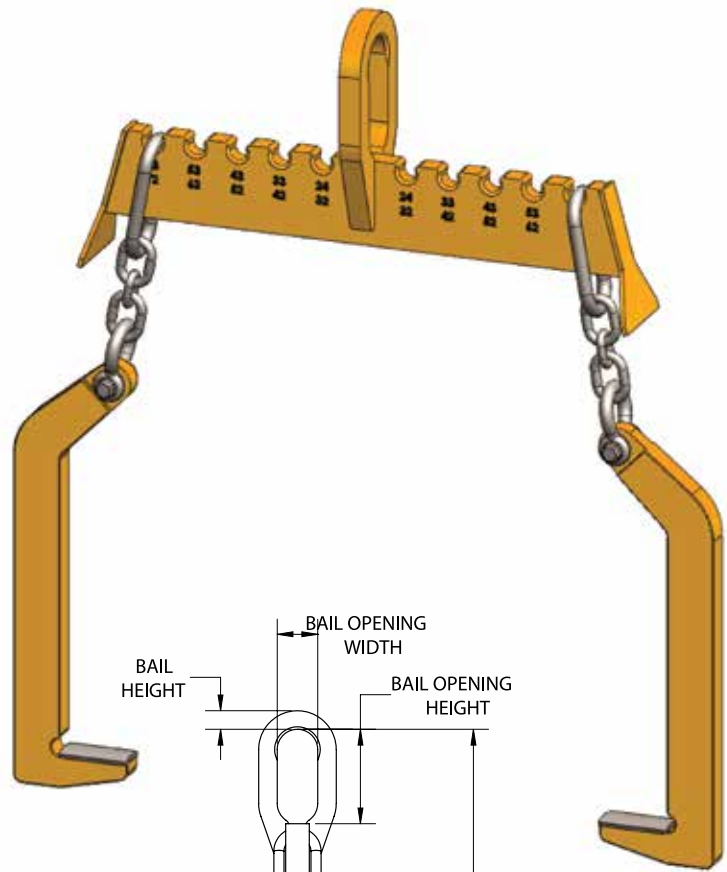

Model #	Capacity (US Tons)*	Dimensions (Inches)										Weight (Lbs.)
		Coil Width Min/Max	Throat Opening Height	Head-room	Foot Height	Foot Width	Foot Length	Bail Height	Bail Opening Width	Bail Opening Height	Bail Thickness	
HNACL-10-48	10	20/48	24	64	4	4	8	2	5	9	1.25	310
HNACL-15-48	15	20/48	28	75	4.25	4	8	2	5	9	1.75	510
HNACL-20-60	20	24/60	30	80	4.5	4	8	2.25	6	12	2	680
HNACL-25-60	25	24/60	34	89	4.5	4	8	2.5	6	14	2.25	870
HNACL-30-72	30	24/72	34	89	4.5	4	8	2.75	6	14	2.5	1100

*1 US Ton = 2,000 lbs.



COIL LIFTER

Custom Application Form



For pricing information: Fax completed form & contact info to 717-665-2861 or email Customer Service at customerservice@harringtonhoists.com

LOAD INFORMATION:

Describe the material you are planning to lift: _____

Coil Lifter Type Needed: _____

Coil Dimensions:

Coil Stand Required: Parking Maintenance None

	Min (in)	Max (in)
O.D.	_____	_____
I.D.	_____	_____
Width/Height	_____	_____
Weight	_____	_____

Coil Positioning During Lift: Eye Vertical Eye Horizontal

Coil Material Steel Aluminum Other (specify): _____

Is Coil Telescoped: Yes No If Yes, Material Length _____ O.D. L.D.

Coil Features: Banded Oily Tight Wound Loose Wound Other (specify): _____

Coil Placement: Prior To Lift: _____ Post Lift: _____

Does The Lifter Require Protective Lining To Prevent Coil Damage: Yes No

Is The Coil Hot: Yes No

If Yes: Max Temp _____ Required Contact Time With Material: _____ Min Time Between Lifts: _____

CRANE SPECIFICATIONS:

Distance Between Top Of The Load To The Crane Hook High Position(s): _____

Capacity Of The Crane(s): _____ Distance Between Cranes (if applicable): _____

Required Duty Cycle Of The Coil Lifter: Lifts Per Hour _____ Lifts Per Day _____

Crane Classification(s): A B C D E F

MOTORIZED COIL LIFTER APPLICATION:

Operation: Manual Motorized: AC DC Voltage _____ Phase _____ Cycle _____

Controls Required: Yes No If Yes: Specify Type _____ Furnish Loose Mounted On Lifter

CRANE HOOK SPECIFICATIONS (Inches) :

A: _____ B: _____ C: _____ D: _____ E: _____ F: _____ G: _____ H: _____

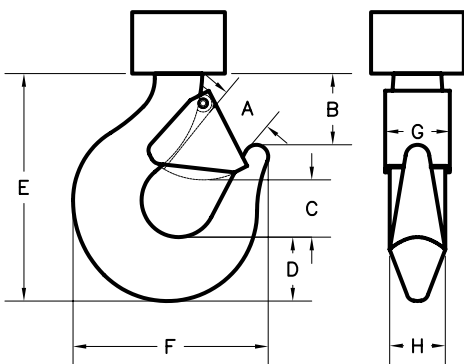

Please provide pertinent application information not supplied above (*extreme product or operating temperature, extreme environmental conditions such as temperature or moisture, space or headroom restrictions, additional specifications*):

Cranes and Crane Components

Heavy Duty Class C Single Girder Series 3
Top Running Complete Cranes

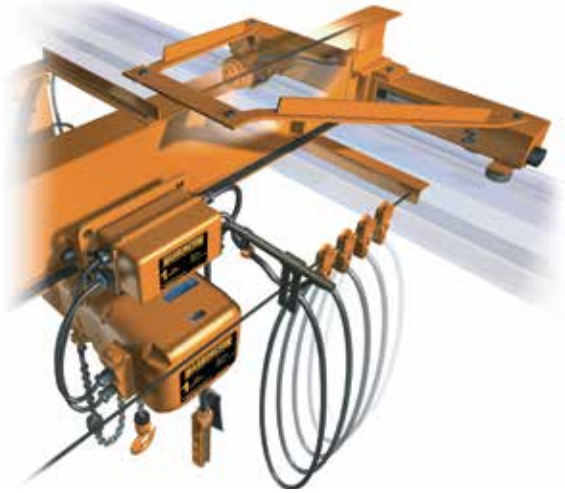

Heavy Duty Class C Single Girder Series 3
Underhung Complete Cranes



TM Single Girder Top Running
Motorized End Trucks



UM Single Girder Underhung
Motorized End Trucks



Tiger Track Jib and Gantry Cranes





HBTF

Bar Tong Fixed Page 62



HBTA

Bar Tong Adjustable..... Page 63



HBTF BAR TONG FIXED

FEATURES

- This style of fixed diameter tong is ideal for lifting round bars, cast or steel pipe.
- The load must be balanced during the lift.
- Can be used in pairs attached to a lifting/spreader beam to handle longer loads.
- Engineered and manufactured to ASME B30.20 & BTH-1 Design Category B Service Class 2.
- 100% of ALL tongs are Proof-Tested to 125% capacity and certificates supplied at No Additional Charge.
- Made in USA.

OPTIONS

- Higher capacities available



TONGS

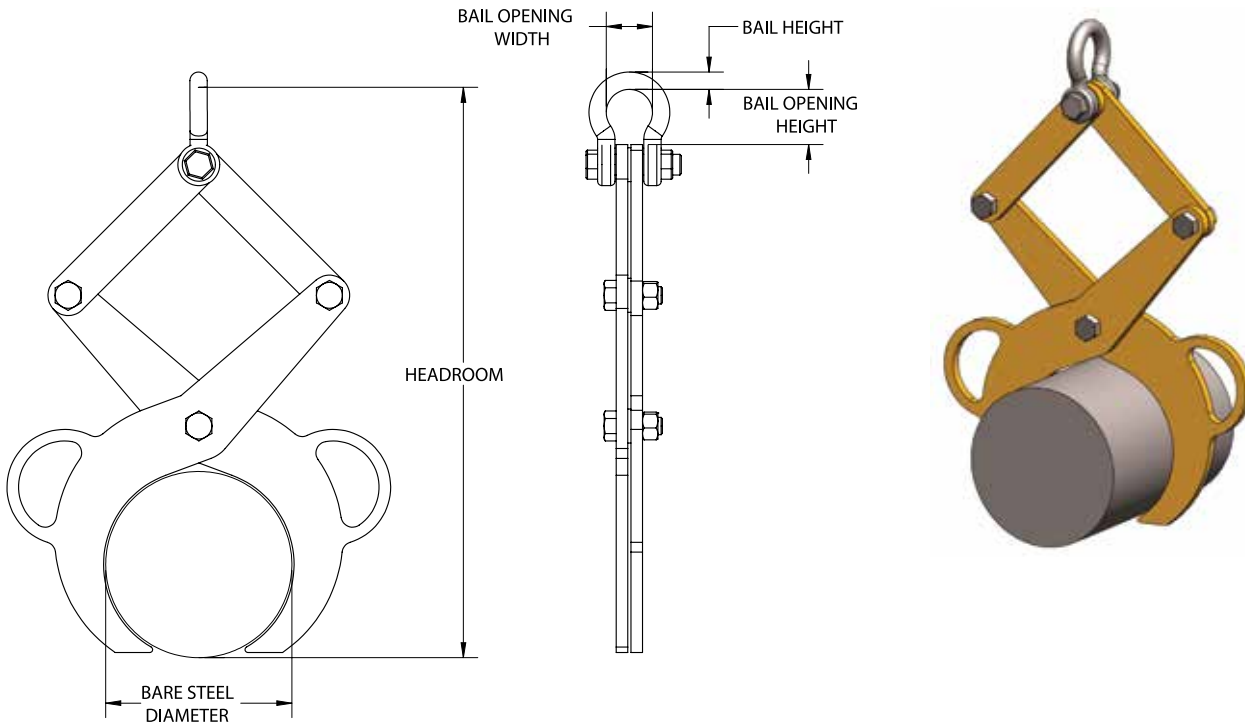

Model #	Capacity (US Tons)*	Dimensions (Inches)					Weight (Lbs.)
		Bare Steel Diameter	Headroom	Bail Height	Bail Opening Width	Bail Opening Height	
HBTF-1/2-5	1/2	5	17.00	0.63	1.69	1.69	17
HBTF-1-8	1	8	25.00	0.75	2	2	25

*1 US Ton = 2,000 lbs.



HBTA BAR TONG ADJUSTABLE

FEATURES

- This style of adjustable diameter tong is ideal for lifting round bars, cast or steel pipe of various diameters.
- Hold open latch supplied on all 1 ton standard tongs.
- Can be supplied with optional replaceable urethane pads for additional load protection.
- The load must be balanced during the lift.
- Can be used in pairs attached to a lifting/spreader beam to handle longer loads.
- Engineered and manufactured to ASME B30.20 & BTH-1 Design Category B Service Class 2.
- 100% of ALL tongs are Proof-Tested to 125% capacity and certificates supplied at No Additional Charge.
- Made in USA.

OPTIONS

- Replaceable urethane pads
- Hold open latch
- Higher capacities available

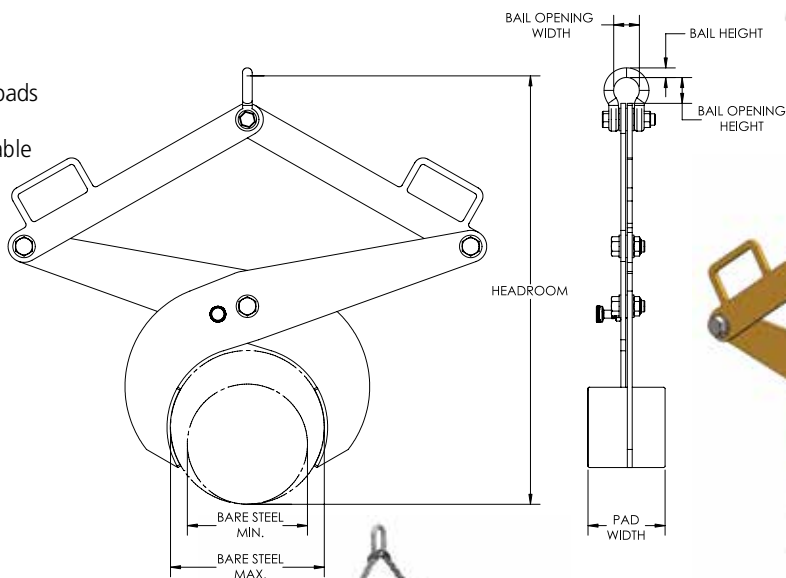
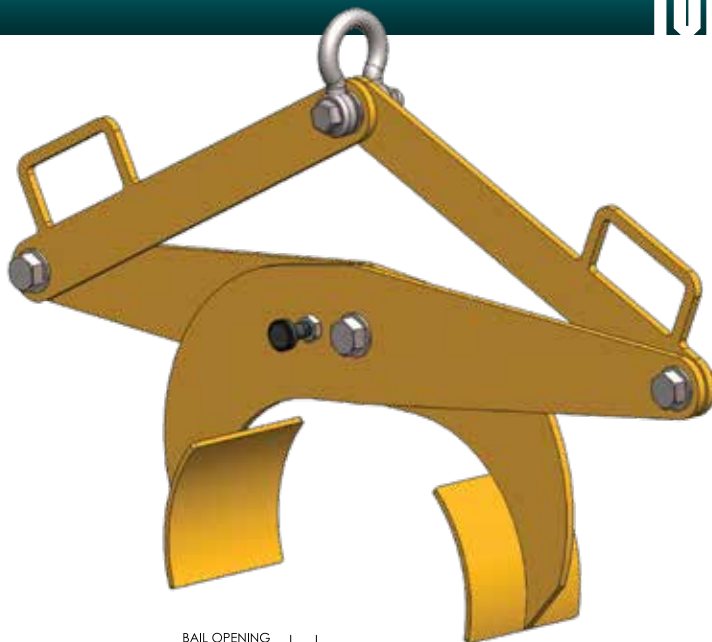

TONGS

Model #	Capacity (US Tons)*	Dimensions (Inches)										Weight (Lbs.)
		Bare Steel Range Min	Bare Steel Range Max	Urethane Pad Range Min	Urethane Pad Range Max	Head-room Min	Head-room Max	Pad Width	Bail Height	Bail Opening Width	Bail Opening Height	
HBTA-1/2-2.5/4	1/2	2.5	4	1.75	3.25	13	15	2.25	0.63	1.69	1.69	10
HBTA-1-4/7	1	4	7	3.25	6.25	21	24	5	0.63	1.69	1.69	25
HBTA-1-7/12	1	7	12	6.25	11.25	34	38	6	0.75	2	2	55
HBTA-1-10/15	1	10	15	9.25	14.25	41	46	6	0.75	2	2	115
HBTA-1-15/20	1	15	20	14.25	19.25	60	65	8	0.97	2.28	2.28	225

*1 US Ton = 2,000 lbs.



DO NOT EXCEED CAPACITY!
See the SAFETY GUIDELINES section before using these products. Pages 92–94.

For pricing information: Fax completed form & contact info to 717-665-2861 or email Customer Service at customerservice@harringtonhoists.com

LOAD INFORMATION:

Describe the material you are planning to lift: _____

Tong Type Needed:

Friction (Designed to lift tubes, rolls, round bars, pipe, & other cylindrical materials)

Friction Tong Load Dimensions:

Min (inches) O.D. _____ I.D. _____ Length _____ Weight _____

Max (inches) O.D. _____ I.D. _____ Length _____ Weight _____

Desired Tong Lift Point: O.D. I.D. Ends

Supporting (Designed to lift crates, boxes, containers, & other square/rectangular shaped materials)

Indentation (Designed to lift ingots, boxes, bales, and other straight sided materials)

Supporting/Indentation Tong Load Dimensions:

Min (inches) Width _____ Length _____ Height _____ Weight _____

Max (inches) Width _____ Length _____ Height _____ Weight _____

Desired Tong Lift Point: Width Side Length Side

Product Positioning Prior Lift: Flat Surface Rack Other (specify): _____

Product Positioning Post Lift: Flat Surface Rack Other (specify): _____

Does Lifter Require Protective Lining To Prevent Damage To The Load: Yes No

Is A Latch Required (Used to assist with hands-free operation): Yes No

Is An Auto-Latch Required (Used to assist with hands-free operation): Yes No

Is The Load Hot: Yes No

If Yes: Max Temp: _____ Required Lifter/Load Contact Time : _____ Min Time Between Lifts _____

CRANE SPECIFICATIONS:

Distance Between Top Of The Load To The Crane Hook High Position: _____

Capacity Of The Crane: _____

Required Duty Cycle Of The Roll Lifter: Lifts Per Hour _____ Lifts Per Day _____

Crane Classification(s): A B C D E F

CRANE HOOK SPECIFICATIONS (Inches) :

A: _____ B: _____ C: _____ D: _____ E: _____ F: _____ G: _____ H: _____

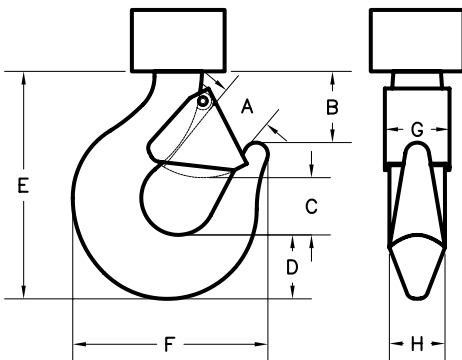

Please provide pertinent application information not supplied above (extreme product or operating temperature, extreme environmental conditions such as temperature or moisture, space or headroom restrictions, additional specifications):

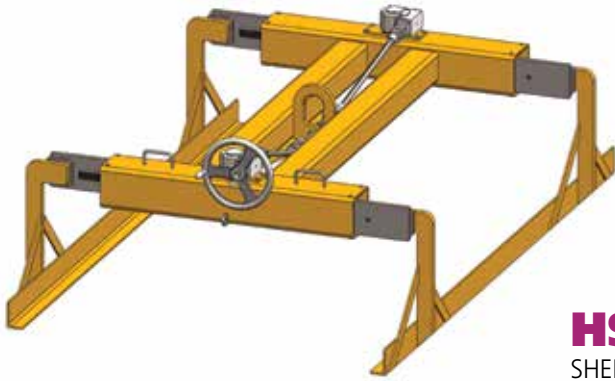

HSLHD

SHEET LIFTER HEAVY DUTYPage 66

HMSLHD

MOTORIZED SHEET LIFTER HEAVY DUTYPage 67

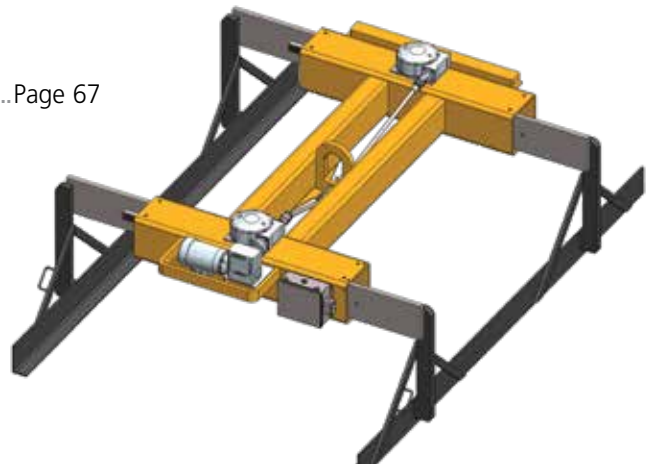

SHEET LIFTERS



HSLLD

SHEET LIFTER LIGHT DUTY.....Page 68

HSLHD SHEET LIFTER HEAVY DUTY

FEATURES

- This style of lifter is designed to lift and carry various sizes of bundles, sheets, and/or plates.
- Standard heavy duty direct drive, self-locking, machined rack and pinion leg adjustment.
- Standard heavy duty square tube H-Frame design.
- Standard heavy duty hand-wheel package with slip clutch to prevent damage to gearboxes from over adjustment.
- Easily maintained low headroom design.
- Engineered and manufactured to ASME B30.20 & BTH-1 Design Category B Service Class 2.
- 100% of ALL sheet lifters are Proof-Tested to 125% capacity and certificates supplied at No Additional Charge.
- Made in USA.

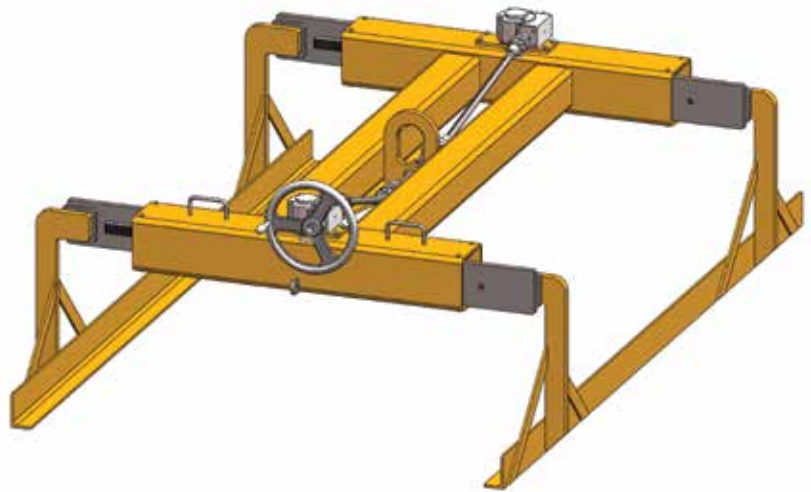

OPTIONS

- Chain wheel leg drive
- Extended hand wheel or chain wheel
- Extended shoe lengths
- Extended leg heights
- Load chains with plate hooks
- Load chains standard on all units with load width capabilities of 72" or greater

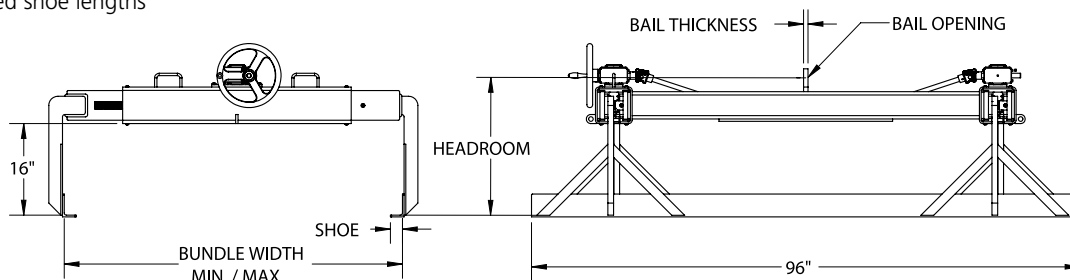

Model #	Capacity (US Tons)*	Dimensions (Inches)								Weight (Lbs.)
		Bundle Width Min/Max	Headroom	Shoe Width	Min. Aisle	Bail Height	Bail Opening Width	Bail Opening Height	Bail Thickness	
HSLHD-3-48	3	16/48	26	2.63	9	1.5	3	5	0.75	1370
HSLHD-3-60	3	16/60	26	2.63	9	1.5	3	5	0.75	1420
HSLHD-3-72	3	16/72	26	2.63	9	1.5	3	5	0.75	1460
HSLHD-5-48	5	16/48	26	2.63	9	2	4	6	1	1670
HSLHD-5-60	5	16/60	26	2.63	9	2	4	6	1	1740
HSLHD-5-72	5	16/72	26	2.63	9	2	4	6	1	1820
HSLHD-5-84	5	16/84	26	2.63	9	2	4	6	1	1890
HSLHD-5-96	5	16/96	26	2.63	9	2	4	6	1	2300
HSLHD-10-48	10	16/48	27	3.5	11	2	4	7	1.5	2700
HSLHD-10-60	10	16/60	27	3.5	11	2	4	7	1.5	2800
HSLHD-10-72	10	16/72	27	3.5	11	2	4	7	1.5	2930
HSLHD-10-84	10	16/84	27	3.5	11	2	4	7	1.5	3030
HSLHD-10-96	10	16/96	27	3.5	11	2	4	7	1.5	3150
HSLHD-15-48	15	16/48	29	3.5	12	2.5	5	9	1.5	2890
HSLHD-15-60	15	16/60	29	3.5	12	2.5	5	9	1.5	3220
HSLHD-15-72	15	16/72	29	3.5	12	2.5	5	9	1.5	3340
HSLHD-15-84	15	38/84	29	3.5	12	2.5	5	9	1.5	3850
HSLHD-15-96	15	38/96	29	3.5	12	2.5	5	9	1.5	3980
HSLHD-20-48	20	16/48	37	5.25	15	2.5	5	9	1.5	3255
HSLHD-20-60	20	16/60	37	5.25	15	2.5	5	9	1.5	3560
HSLHD-20-72	20	16/72	37	5.25	15	2.5	5	9	1.5	3875
HSLHD-20-84	20	38/84	37	5.25	15	2.5	5	9	1.5	4550
HSLHD-20-96	20	38/96	37	5.25	15	2.5	5	9	1.5	4900

*1 US Ton = 2,000 lbs.



DO NOT EXCEED CAPACITY!
See the SAFETY GUIDELINES section before using these products. Pages 92-94.

HMSLHD MOTORIZED SHEET LIFTER HEAVY DUTY

FEATURES

- This style of lifter is designed to lift and carry various sizes of bundles, sheets, and/or plates.
- Standard heavy duty direct drive, self-locking, machined rack and pinion leg adjustment.
- Standard heavy duty square tube H-Frame design.
- Standard heavy duty motor package with slip clutch to prevent damage to gearboxes from over adjustment.
- Easily maintained low headroom design.
- Engineered and manufactured to ASME B30.20 & BTH-1 Design Category B Service Class 2.
- 100% of ALL sheet lifters are Proof-Tested to 125% capacity and certificates supplied at No Additional Charge.
- Made in USA.

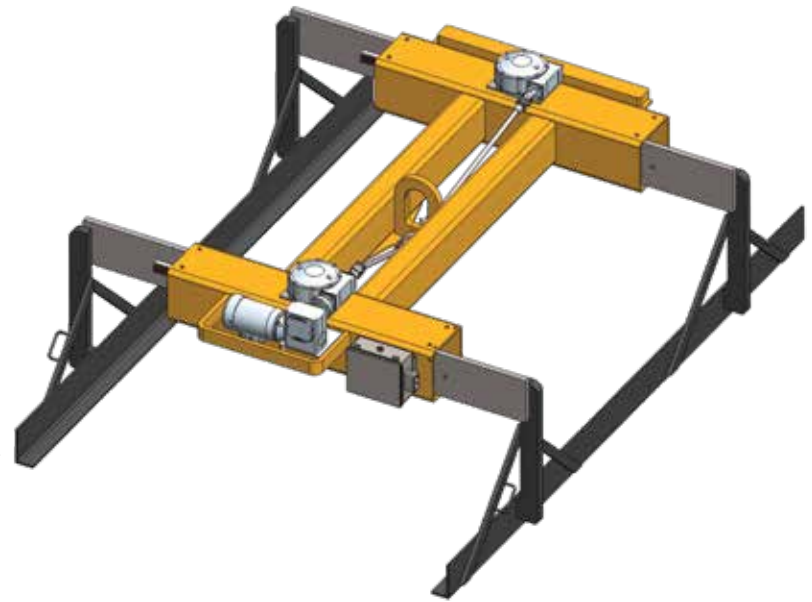

OPTIONS

- Extended shoe lengths
- Extended leg heights
- Load chains with plate hooks
- Load chains standard on all units with load width capabilities of 72" or greater

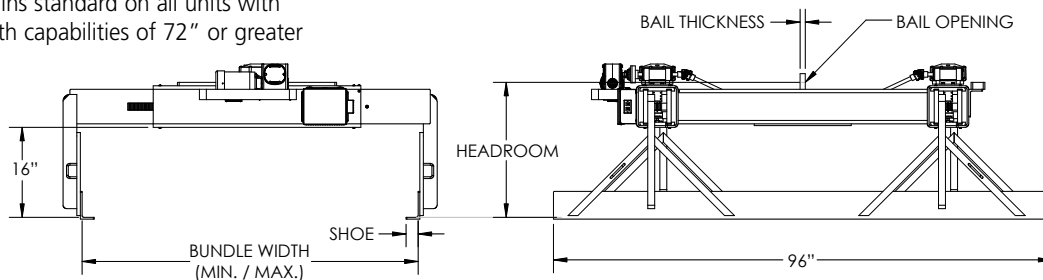

Model #	Capacity (US Tons)*	Dimensions (Inches)								Weight (Lbs.)
		Bundle Width Min/Max	Headroom	Shoe Width	Min. Aisle	Bail Height	Bail Opening Width	Bail Opening Height	Bail Thickness	
HMSLHD-3-48	3	16/48	26	2.63	9	1.5	3	5	0.75	1770
HMSLHD-3-60	3	16/60	26	2.63	9	1.5	3	5	0.75	1820
HMSLHD-3-72	3	16/72	26	2.63	9	1.5	3	5	0.75	1860
HMSLHD-5-48	5	16/48	26	2.63	9	2	4	6	1	2070
HMSLHD-5-60	5	16/60	26	2.63	9	2	4	6	1	2140
HMSLHD-5-72	5	16/72	26	2.63	9	2	4	6	1	2220
HMSLHD-5-84	5	16/84	26	2.63	9	2	4	6	1	2290
HMSLHD-5-96	5	16/96	26	2.63	9	2	4	6	1	2700
HMSLHD-10-48	10	16/48	27	3.5	11	2	4	7	1.5	3100
HMSLHD-10-60	10	16/60	27	3.5	11	2	4	7	1.5	3200
HMSLHD-10-72	10	16/72	27	3.5	11	2	4	7	1.5	3330
HMSLHD-10-84	10	16/84	27	3.5	11	2	4	7	1.5	3430
HMSLHD-10-96	10	16/96	27	3.5	11	2	4	7	1.5	3450
HMSLHD-15-48	15	16/48	29	3.5	12	2.5	5	9	1.5	3290
HMSLHD-15-60	15	16/60	29	3.5	12	2.5	5	9	1.5	3620
HMSLHD-15-72	15	16/72	29	3.5	12	2.5	5	9	1.5	3740
HMSLHD-15-84	15	38/84	29	3.5	12	2.5	5	9	1.5	4250
HMSLHD-15-96	15	38/96	29	3.5	12	2.5	5	9	1.5	4380
HMSLHD-20-48	20	16/48	37	5.25	15	2.5	5	9	1.5	3655
HMSLHD-20-60	20	16/60	37	5.25	15	2.5	5	9	1.5	3960
HMSLHD-20-72	20	16/72	37	5.25	15	2.5	5	9	1.5	4275
HMSLHD-20-84	20	38/84	37	5.25	15	2.5	5	9	1.5	4900
HMSLHD-20-96	20	38/96	37	5.25	15	2.5	5	9	1.5	5200

*1 US Ton = 2,000 lbs.



DO NOT EXCEED CAPACITY!
See the SAFETY GUIDELINES section before using these products. Pages 92–94.

HSLLD SHEET LIFTER LIGHT DUTY

FEATURES

- This style of lifter is designed to lift and carry smaller sizes of bundles, sheets, and/or plates.
- Standard direct drive, self-locking, rack and pinion leg adjustment.
- Standard hand-wheel with slip clutch to prevent damage to gearboxes from over adjustment.
- Utilizes a sling style bail that adds stability and provides ease of maintenance on the gearbox and pinion gear assembly.
- Easily maintained low headroom design.
- Engineered and manufactured to ASME B30.20 & BTH-1 Design Category B Service Class 2.
- 100% of ALL sheet lifters are Proof-Tested to 125% capacity and certificates supplied at No Additional Charge.
- Made in USA.

OPTIONS

- Chain wheel leg drive
- Extended hand wheel or chain wheel
- Extended shoe lengths
- Extended leg heights
- Load chains with plate hooks

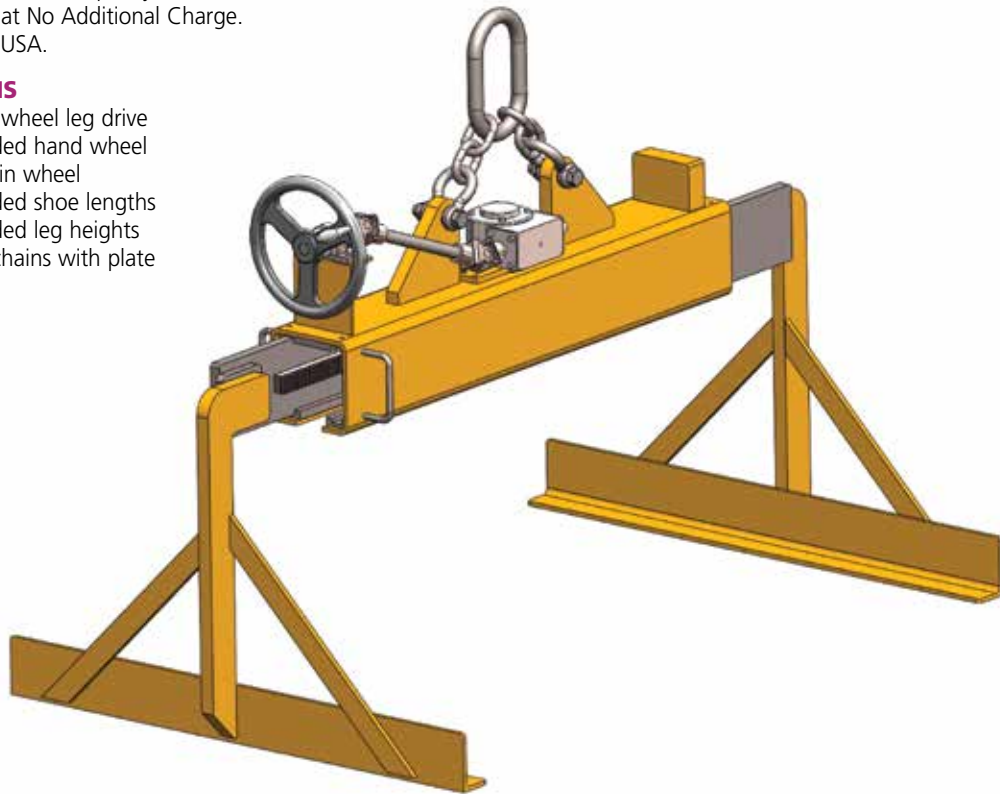
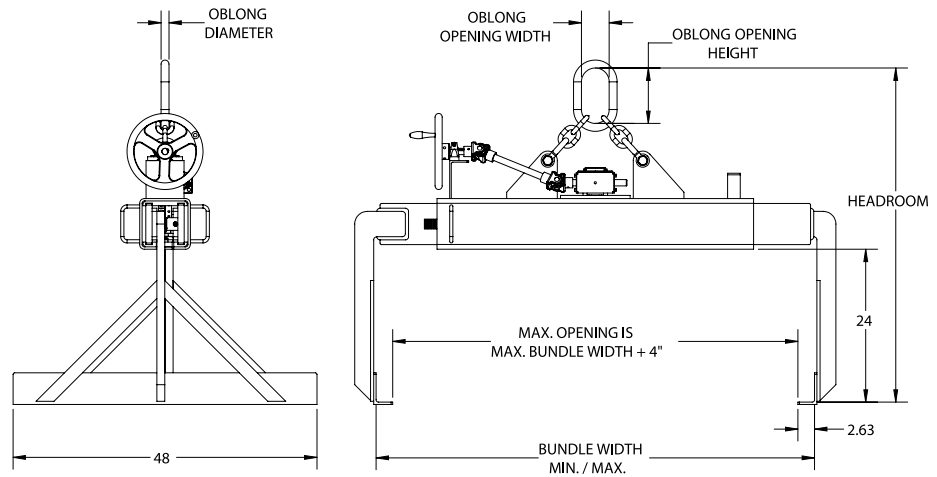

Model #	Capacity (US Tons)*	Dimensions (Inches)							Weight (Lbs.)
		Bundle Width Min/Max	Headroom	Shoe Width	Min. Aisle	Oblong ML Diameter	Oblong ML Opening Width	Oblong ML Opening Height	
HSLLD-1.5-36	1.5	12/36	44	2.63	8	0.63	3	6	507
HSLLD-1.5-48	1.5	16/48	44	2.63	8	0.63	3	6	520
HSLLD-3-48	3	16/48	46	2.63	8	1	3.5	7	660
HSLLD-3-60	3	20/60	46	2.63	8	1	3.5	7	730
HSLLD-5-48	5	16/48	54	2.63	8	1	4.38	8.75	745
HSLLD-5-60	5	20/60	54	2.63	8	1	4.38	8.75	755

*1 US Ton = 2,000 lbs.



DO NOT EXCEED CAPACITY!
See the SAFETY GUIDELINES section before using these products. Pages 92-95.

SHEET LIFTER

Custom Application Form



For pricing information: Fax completed form & contact info to 717-665-2861 or email Customer Service at customerservice@harringtonhoists.com

LOAD INFORMATION:

Describe the material you are planning to lift: _____

Material Conditions: Banded Loose Dry Oily

Bundled Load Dimensions:

Manual (adjustment): Yes No

	Min (in)	Max (in)
Height	_____	_____
Width	_____	_____
Length	_____	_____
Weight	_____	_____

If Yes: Max Temp ___ Req Contact Time ___ Min Time Between Lifts ___

Will Individual Sheets Be Handled? Yes No

If Yes: Individual Sheet Plate Thickness (inches) Max _____ Min _____

Is The Load Palletized? Yes No

If Yes: Pallet Dimensions (inches) Height _____ Width _____ Length _____ Weight _____

SHEET LIFTER SPECIFICATIONS:

Operation: Manual Motorized Hydraulic

If Manual (adjustment): Hand Wheel Chain Wheel Extended Reach

If Motorized: AC DC Voltage _____ Phase _____ Cycle _____

If Yes Specify Type _____ Furnish Loose Mounted On Lifter

Controls Required: Yes No

Load Chains With Plate Hooks: Yes No

Distance Between Top Of The Load To The Crane Hook High Position(s): _____

Capacity Of The Crane(s): _____

Required Duty Cycle Of The Sheet Lifter: Lifts Per Hour _____ Lifts Per Day _____

Crane Classification(s): A B C D E F

CRANE HOOK SPECIFICATIONS (Inches):

A: ___ B: ___ C: ___ D: ___ E: ___ F: ___ G: ___ H: ___

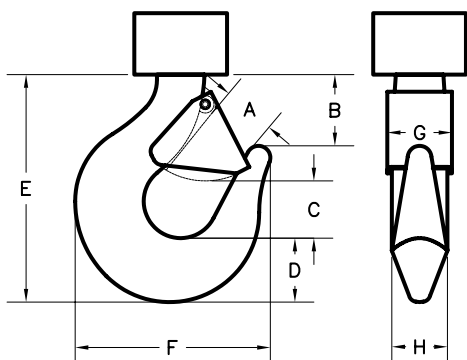

Please provide pertinent application information not supplied above (extreme product or operating temperature, extreme environmental conditions such as temperature or moisture, space or headroom restrictions, additional specifications):

Electric Hoist Products

NERM/ERM Electric Chain Hoists with Motorized Trolleys



NERM/ERM Large Capacity Electric Chain Hoists with Motorized Trolleys



ED Electric Chain Hoists



RHN Electric Wire Rope Ultra-Low Headroom Trolley Hoists



SNER Series Electric Hoists





HPL
FIXED FORK PALLET LIFTERPage 72



HPLAF
ADJUSTABLE FORK PALLET LIFTER.....Page 73



HPLHW
ADJUSTABLE FORK PALLET LIFTER.....Page 74



HPLHD
FIXED FORK HEAVY DUTY PALLET LIFTER.....Page 75



HPLHA
ADJUSTABLE FORK HEAVY DUTY PALLET LIFTER.....Page 76



HPLAH
ADJUSTABLE FORK HEAVY DUTY PALLET LIFTER
w/Hand Wheel.....Page 77



HPLWL
WHEELED PALLET LIFTERPage 78



HPLLW
LIGHTWEIGHT PALLET LIFTERPage 79

HPL FIXED FORK PALLET LIFTER

FEATURES

- This style of lifter is designed to lift and carry palletized loads efficiently with an overhead crane.
- Counter balanced to hang level when unloaded.
- Easily maintained low headroom design.
- The bail is a lower headroom design and is positioned to avoid side loading the crane hook.
- Engineered and manufactured to ASME B30.20 & BTH-1 Design Category B Service Class 2.
- 100% of ALL pallet lifters are Proof-Tested to 125% capacity and certificates supplied at No Additional Charge.
- Made in USA.

OPTIONS

- Larger throat openings
- Greater outside fork widths
- Additional sizes and capacities available

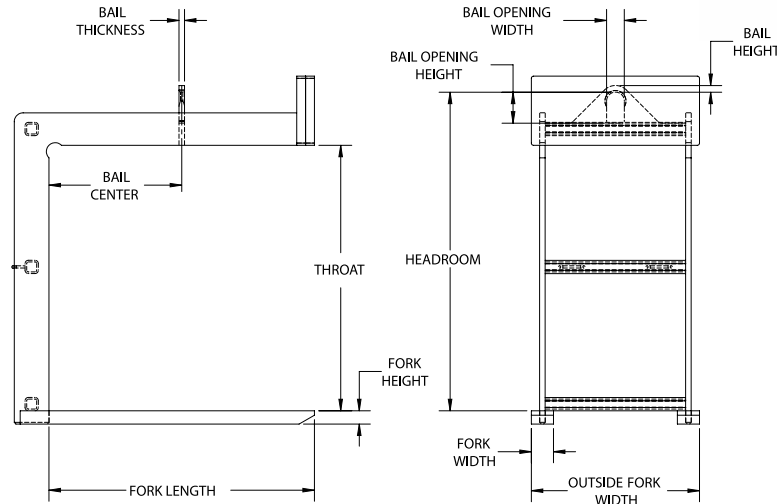
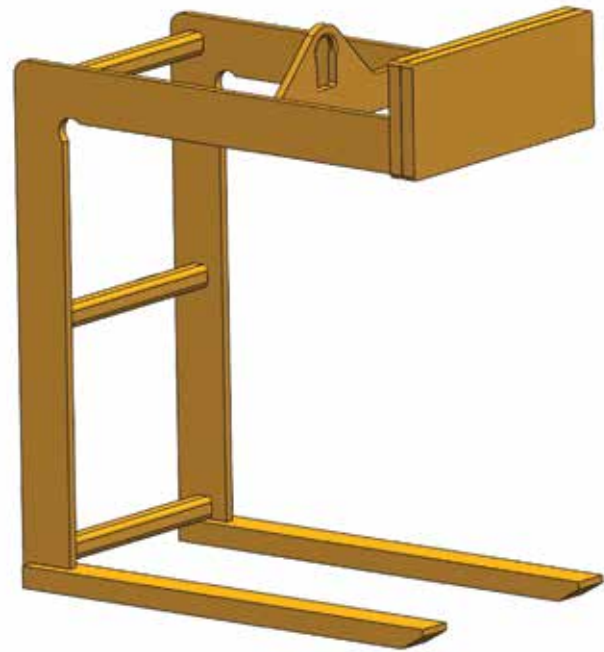

PALLET LIFTERS

Model #	Capacity (US Tons)*	Dimensions (Inches)											Weight (Lbs.)
		Fork Length	Fork Width	Fork Height	Outside Fork Width	Bail Center	Throat Opening Height	Headroom	Bail Height	Bail Opening Width	Bail Opening Height	Bail Thickness	
HPL-1-36	1	36	2	2	25	18	48	57.5	0.88	3	5	0.75	425
HPL-1-42	1	42	2	2	25	21	48	57.5	0.88	3	5	0.75	450
HPL-1-48	1	48	2	2	25	24	48	58.5	0.88	3	5	0.75	540
HPL-1.5-36	1.5	36	3	2	25	18	48	58.5	0.88	3	5	0.75	565
HPL-1.5-42	1.5	42	3	2	25	21	48	58.5	0.88	3	5	0.75	630
HPL-1.5-48	1.5	48	3	2	25	24	48	58.5	0.88	3	5	0.75	665
HPL-2-36	2	36	3	2	25	18	48	59.5	0.88	3	5	0.75	650
HPL-2-42	2	42	4	2	25	21	48	59.5	0.88	3	5	0.75	780
HPL-2-48	2	48	4	2	25	24	48	59.5	0.88	3	5	0.75	910
HPL-3-42	3	42	4.5	2.5	25	21	48	61.5	1.25	3	5	1	1110
HPL-3-48	3	48	4.5	2.5	27	24	48	61.5	1.25	3	5	1	1195
HPL-3-54	3	54	4.5	2.5	30	27	48	61.5	1.25	3	5	1	1405
HPL-4-48	4	48	5	3	27	24	48	63.5	1.25	3	5	1	1705
HPL-4-60	4	60	5	3	30	30	60	75.5	1.25	3	5	1	2020
HPL-5-48	5	48	5	3	30	24	48	63.5	1.5	4	7	1.25	1730
HPL-5-60	5	60	5	3	38	30	60	75.5	1.5	4	7	1.25	2035

NOTE: Additional 2"-3" clearance is recommended above the load for ease of loading and unloading the pallet lifter.

*1 US Ton = 2,000 lbs.



HPLAF ADJUSTABLE FORK PALLET LIFTER

FEATURES

- This style of lifter is designed to lift and carry palletized loads efficiently with an overhead crane.
- Supplied standard with manually adjustable forks that allow the lifter to handle various pallet sizes.
- Counter balanced to hang level when unloaded.
- Easily maintained low headroom design.
- The bail is a lower headroom design and is positioned to avoid side loading the crane hook.
- Engineered and manufactured to ASME B30.20 & BTH-1 Design Category B Service Class 2.
- 100% of ALL pallet lifters are Proof-Tested to 125% capacity and certificates supplied at No Additional Charge.
- Made in USA.

OPTIONS

- Larger throat openings
- Greater outside fork widths
- Additional sizes and capacities available

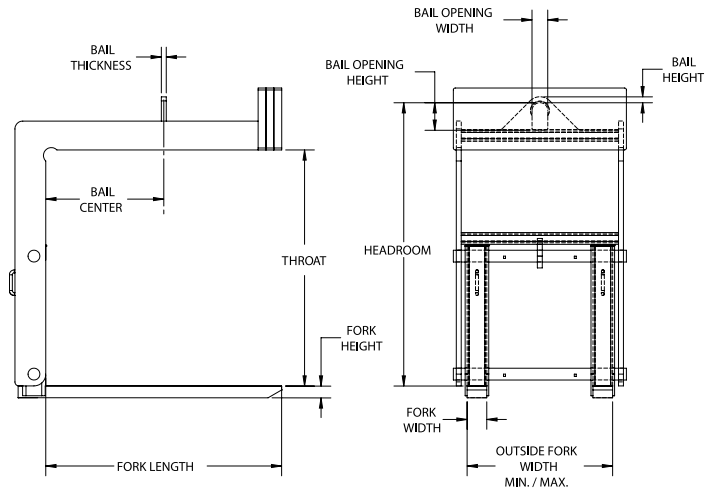

Model #	Capacity (US Tons)*	Dimensions (Inches)											Weight (Lbs.)
		Fork Length	Fork Width	Fork Height	Outside Fork Width Min/Max	Bail Center	Throat Opening Height	Head-room	Bail Height	Bail Opening Width	Bail Opening Height	Bail Thickness	
HPLAF-1-36	1	36	2	2	16/38	18	48	58	0.88	3	5	0.75	900
HPLAF-1-42	1	42	2	2	16/38	21	48	58	0.88	3	5	0.75	1025
HPLAF-1-48	1	48	2	2	16/38	24	48	59	0.88	3	5	0.75	1050
HPLAF-1.5-36	1.5	36	3	2	16/38	18	48	59	0.88	3	5	0.75	1140
HPLAF-1.5-42	1.5	42	3	2	16/38	21	48	59	0.88	3	5	0.75	1215
HPLAF-1.5-48	1.5	48	3	2	16/38	24	48	60	0.88	3	5	0.75	1285
HPLAF-2-36	2	36	3	2	16/38	18	48	60	0.88	3	5	0.75	1325
HPLAF-2-42	2	42	4	2	16/38	21	48	60	0.88	3	5	0.75	1435
HPLAF-2-48	2	48	4	2	16/38	24	48	60	0.88	3	5	0.75	1460
HPLAF-3-42	3	42	4.5	2.5	16/38	21	48	61.5	1.25	3	5	1	1690
HPLAF-3-48	3	48	4.5	2.5	16/38	24	48	61.5	1.25	3	5	1	1850
HPLAF-3-54	3	54	4.5	2.5	16/38	27	48	63	1.25	3	5	1	2700
HPLAF-4-48	4	48	5	3	16/38	24	48	64	1.25	3	5	1	2160
HPLAF-4-60	4	60	5	3	16/38	30	60	76	1.25	3	5	1	3025
HPLAF-5-48	5	48	5	3	16/38	24	48	65	1.5	4	7	1.25	2520
HPLAF-5-60	5	60	5	3	16/38	30	60	77	1.5	4	7	1.25	2960

NOTE: Additional 2"-3" clearance is recommended above the load for ease of loading and unloading the pallet lifter.

*1 US Ton = 2,000 lbs.



DO NOT EXCEED CAPACITY!
See the SAFETY GUIDELINES section before using these products. Pages 92-94.

HPLHW ADJUSTABLE FORK PALLET LIFTER w/HAND WHEEL

FEATURES

- This style of lifter is designed to lift and carry palletized loads efficiently with an overhead crane.
- Supplied standard with a hand wheel to adjust forks to allow the lifter to handle various pallet sizes.
- Counter balanced to hang level when unloaded.
- Easily maintained low headroom design.
- The bail is a lower headroom design and is positioned to avoid side loading the crane hook.
- Engineered and manufactured to ASME B30.20 & BTH-1 Design Category B Service Class 2.
- 100% of ALL pallet lifters are Proof-Tested to 125% capacity and certificates supplied at No Additional Charge.
- Made in USA.

OPTIONS

- Larger throat openings
- Greater outside fork widths
- Additional sizes and capacities available

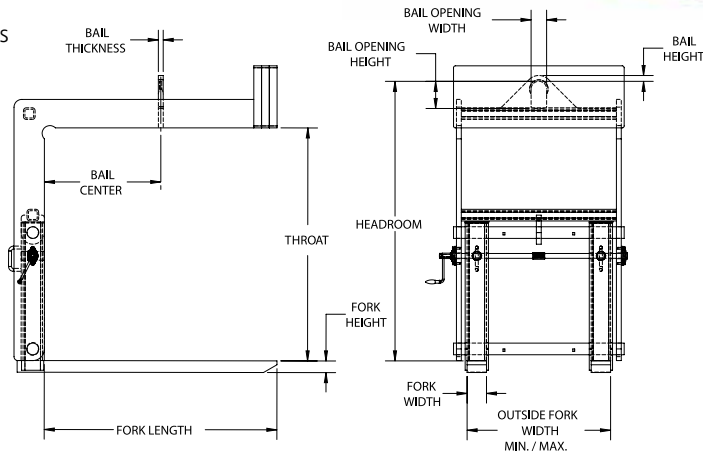

PALLET LIFTERS

Model #	Capacity (US Tons)*	Dimensions (Inches)											Weight (Lbs.)
		Fork Length	Fork Width	Fork Height	Outside Fork Width Min/Max	Bail Center	Throat Opening Height	Head-room	Bail Height	Bail Opening Width	Bail Opening Height	Bail Thickness	
HPLHW-1-36	1	36	2	2	16/38	18	48	58	0.88	3	5	0.75	950
HPLHW-1-42	1	42	2	2	16/38	21	48	58	0.88	3	5	0.75	1075
HPLHW-1-48	1	48	2	2	16/38	24	48	59	0.88	3	5	0.75	1100
HPLHW-1.5-36	1.5	36	3	2	16/38	18	48	59	0.88	3	5	0.75	1190
HPLHW-1.5-42	1.5	42	3	2	16/38	21	48	59	0.88	3	5	0.75	1265
HPLHW-1.5-48	1.5	48	3	2	16/38	24	48	60	0.88	3	5	0.75	1335
HPLHW-2-36	2	36	3	2	16/38	18	48	60	0.88	3	5	0.75	1275
HPLHW-2-42	2	42	4	2	16/38	21	48	60	0.88	3	5	0.75	1485
HPLHW-2-48	2	48	4	2	16/38	24	48	60	0.88	3	5	0.75	1510
HPLHW-3-42	3	42	4.5	2.5	16/38	21	48	61.5	1.25	3	5	1	1740
HPLHW-3-48	3	48	4.5	2.5	16/38	24	48	61.5	1.25	3	5	1	1900
HPLHW-3-54	3	54	4.5	2.5	16/38	27	48	63	1.25	3	5	1	2750
HPLHW-4-48	4	48	5	3	16/38	24	48	64	1.25	3	5	1	2210
HPLHW-4-60	4	60	5	3	16/38	30	60	76	1.25	3	5	1	3075
HPLHW-5-48	5	48	5	3	16/38	24	48	65	1.5	4	7	1.25	2570
HPLHW-5-60	5	60	5	3	16/38	30	60	77	1.5	4	7	1.25	3010

NOTE: Additional 2"-3" clearance is recommended above the load for ease of loading and unloading the pallet lifter.

*1 US Ton = 2,000 lbs.



HPLHD FIXED FORK HEAVY DUTY PALLET LIFTER

FEATURES

- This style of lifter is designed with a double frame to lift and carry heavy palletized loads efficiently with an overhead crane.
- Counter balanced to hang level when unloaded.
- Easily maintained low headroom design.
- The bail is a lower headroom design and is positioned to avoid side loading the crane hook.
- Engineered and manufactured to ASME B30.20 & BTH-1 Design Category B Service Class 2.
- 100% of ALL pallet lifters are Proof-Tested to 125% capacity and certificates supplied at No Additional Charge.
- Made in USA.

OPTIONS

- Larger throat openings
- Greater outside fork widths
- Additional sizes and capacities available

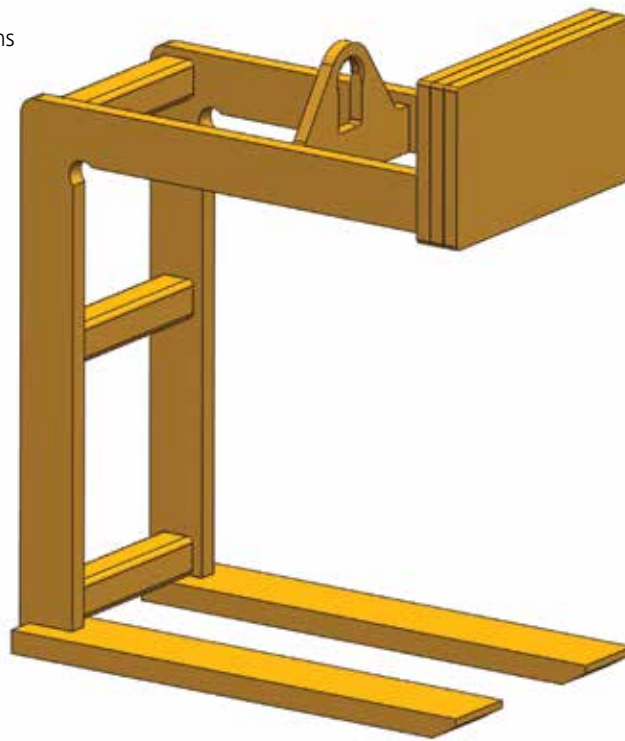
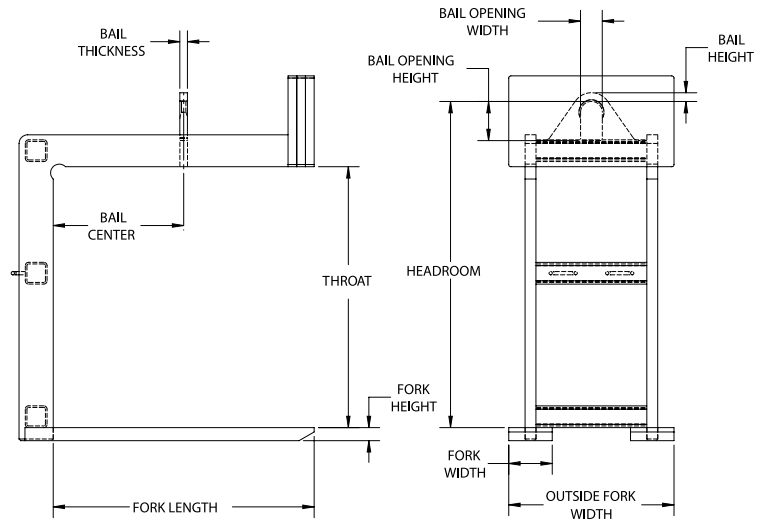

Model #	Capacity (US Tons)*	Dimensions (Inches)											Weight (Lbs.)
		Fork Length	Fork Width	Fork Height	Outside Fork Width	Bail Center	Throat Opening Height	Head-room	Bail Height	Bail Opening Width	Bail Opening Height	Bail Thickness	
HPLHD-7.5-48	7.5	48	6	3	30	24	48	65	1.50	4	7	1.50	2485
HPLHD-7.5-60	7.5	60	8	3	38	30	60	79	1.50	4	7	1.50	3120
HPLHD-10-48	10	48	8	3	30	24	48	69	2	5	9	1.75	2540
HPLHD-10-60	10	60	10	3	38	30	60	81	2	5	9	1.75	4025
HPLHD-15-48	15	48	10	3	38	24	60	84	2	5	9	1.75	2925
HPLHD-15-60	15	60	10	3.5	38	30	60	75	2	5	9	1.75	4940
HPLHD-20-60	20	60	10	4	38	30	60	88	2.25	6	12	2	5590
HPLHD-20-72	20	72	12	4	44	36	60	88	2.25	6	12	2	6300

NOTE: Additional 2"-3" clearance is recommended above the load for ease of loading and unloading the pallet lifter.

*1 US Ton = 2,000 lbs.



DO NOT EXCEED CAPACITY!
See the SAFETY GUIDELINES section before using these products. Pages 92-94.

HPLHA ADJUSTABLE FORK HEAVY DUTY PALLET LIFTER

FEATURES

- This style of lifter is designed with a double frame and forged forks to lift and carry heavy palletized loads efficiently with an overhead crane.
- Supplied standard with manually adjustable forks that allow the lifter to handle various pallet sizes.
- Counter balanced to hang level when unloaded.
- Easily maintained low headroom design.
- The bail is a lower headroom design and is positioned to avoid side loading the crane hook.
- Engineered and manufactured to ASME B30.20 & BTH-1 Design Category B Service Class 2.
- 100% of ALL pallet lifters are Proof-Tested to 125% capacity and certificates supplied at No Additional Charge.
- Made in USA.

OPTIONS

- Larger throat openings
- Greater outside fork widths
- Additional sizes and capacities available

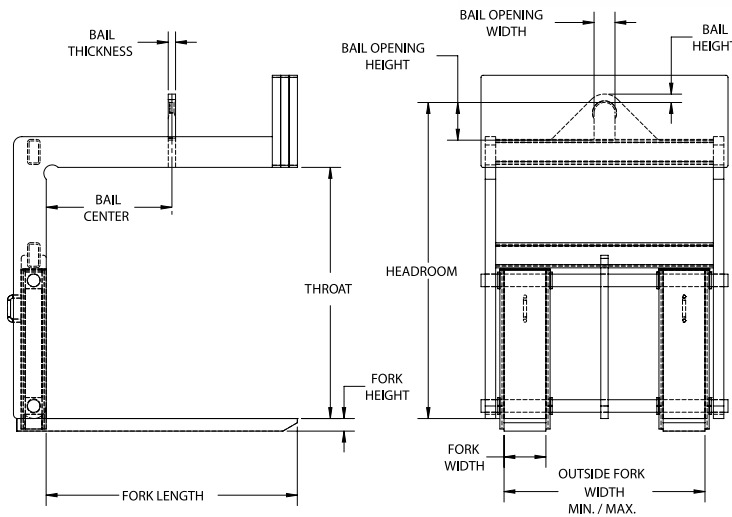

PALLET LIFTERS

Model #	Capacity (US Tons)*	Dimensions (Inches)											Weight (Lbs.)
		Fork Length	Fork Width	Fork Height	Outside Fork Width Min/Max	Bail Center	Throat Opening Height	Headroom	Bail Height	Bail Opening Width	Bail Opening Height	Bail Thickness	
HPLHA-7.5-48	7.5	48	6	3	16/48	24	48	61	1.50	4	7	1.50	3200
HPLHA-7.5-60	7.5	60	8	3	20/48	30	60	74	1.50	4	7	1.50	4300
HPLHA-7.5-72	7.5	72	10	3	24/48	36	60	76	1.50	4	7	1.50	4900
HPLHA-10-48	10	48	8	3	20/48	24	48	64	2	5	9	1.75	3800
HPLHA-10-60	10	60	10	3	24/48	30	60	76	2	5	9	1.75	5600
HPLHA-10-72	10	72	10	3.5	24/48	36	60	76	2	5	9	1.75	6400
HPLHA-12.5-48	12.5	48	8	3	16/48	24	48	78	2	5	9	1.75	5100
HPLHA-12.5-60	12.5	60	10	3	24/48	30	60	78	2	5	9	1.75	6200
HPLHA-12.5-72	12.5	72	10	3.5	24/48	36	60	78	2	5	9	1.75	7200

NOTE: Additional 2"-3" clearance is recommended above the load for ease of loading and unloading the pallet lifter.

*1 US Ton = 2,000 lbs.



HPLAH ADJUSTABLE FORK HEAVY DUTY PALLET LIFTER w/Hand Wheel

FEATURES

- This style of lifter is designed with a double frame and forged forks to lift and carry heavy palletized loads efficiently with an overhead crane.
- Supplied standard with a hand wheel to adjust forks to allow the lifter to handle various pallet sizes.
- Counter balanced to hang level when unloaded.
- Easily maintained low headroom design.
- The bail is a lower headroom design and is positioned to avoid side loading the crane hook.
- Engineered and manufactured to ASME B30.20 & BTH-1 Design Category B Service Class 2.
- 100% of ALL pallet lifters are Proof-Tested to 125% capacity and certificates supplied at No Additional Charge.
- Made in USA.

OPTIONS

- Larger throat openings
- Greater outside fork widths
- Additional sizes and capacities available

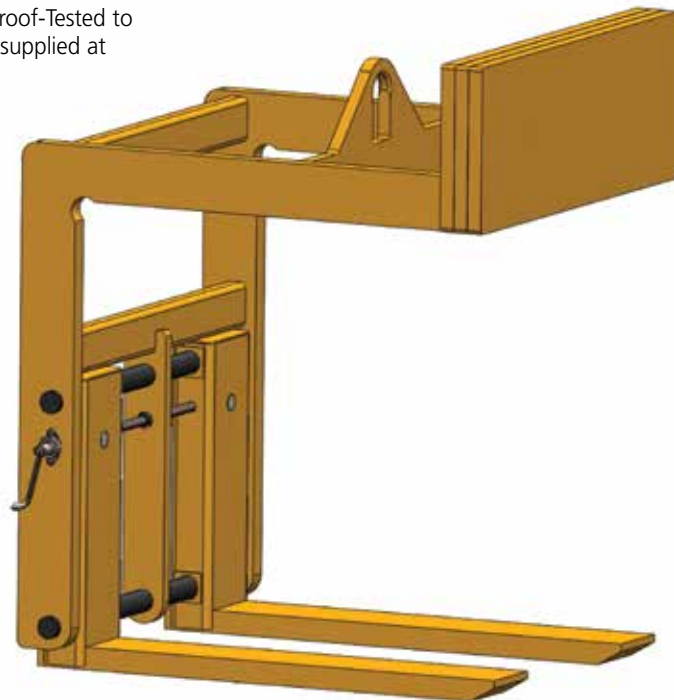
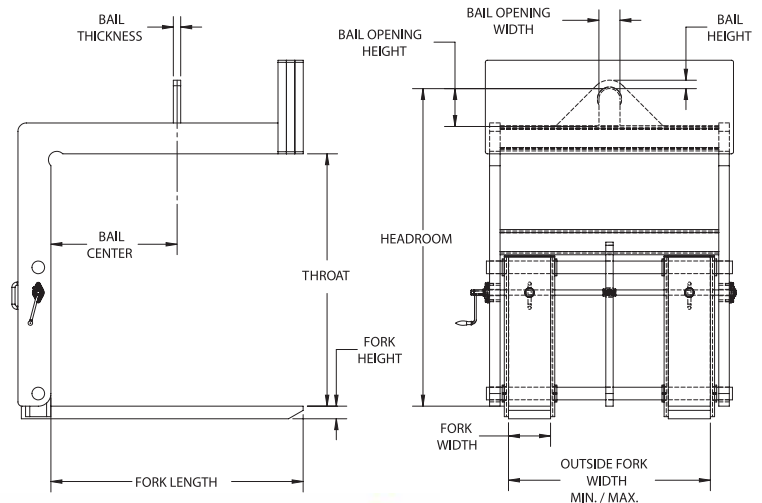

Model #	Capacity (US Tons)*	Dimensions (Inches)											Weight (Lbs.)
		Fork Length	Fork Width	Fork Height	Outside Fork Width Min/Max	Bail Center	Throat Opening Height	Head-room	Bail Height	Bail Opening Width	Bail Opening Height	Bail Thickness	
HPLAH-7.5-48	7.5	48	6	3	16/48	24	48	66	1.50	4	7	1.50	3350
HPLAH-7.5-60	7.5	60	8	3	20/48	30	60	77.5	1.50	4	7	1.50	4550
HPLAH-7.5-72	7.5	72	10	3	24/48	36	60	80	1.50	4	7	1.50	5050
HPLAH-10-48	10	48	8	3	20/48	24	48	65.5	2	5	9	1.75	3950
HPLAH-10-60	10	60	10	3	24/48	30	60	77.5	2	5	9	1.75	5750
HPLAH-10-72	10	72	10	3.5	24/48	36	60	82	2	5	9	1.75	6550
HPLAH-12.5-48	12.5	48	8	3	16/48	24	48	82	2	5	9	1.75	5250
HPLAH-12.5-60	12.5	60	10	3	24/48	30	60	82	2	5	9	1.75	6350
HPLAH-12.5-72	12.5	72	10	3.5	24/48	36	60	82	2	5	9	1.75	7350
HPLAH-15-60	15	60	10	3.5	24/48	30	60	82	2	5	9	1.75	7050
HPLAH-15-72	15	72	12	3.5	28/48	36	60	82.5	2	5	9	1.75	8450

NOTE: Additional 2"-3" clearance is recommended above the load for ease of loading and unloading the pallet lifter.

*1 US Ton = 2,000 lbs.



DO NOT EXCEED CAPACITY!
See the SAFETY GUIDELINES section before using these products. Pages 92-94.

HPLWL WHEELED PALLET LIFTER

FEATURES

- This style of lifter is designed to lift and carry palletized loads efficiently with an overhead crane.
- Wheeled design allows for ease of movement to the load and dual lift points allow the lifter to hang level when unloaded.
- Easily maintained low headroom design.
- Engineered and manufactured to ASME B30.20 & BTH-1 Design Category B Service Class 2.
- 100% of ALL pallet lifters are Proof-Tested to 125% capacity and certificates supplied at No Additional Charge.
- Made in USA.

OPTIONS

- Larger throat openings
- Greater outside fork widths
- Additional sizes and capacities available

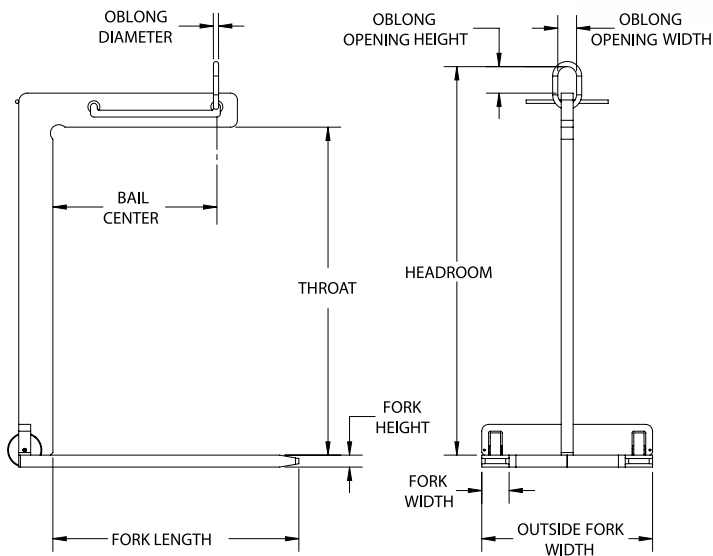

Model #	Capacity (US Tons)*	Dimensions (Inches)										Weight (Lbs.)
		Fork Length	Fork Width	Fork Height	Outside Fork Width	Bail Center	Throat Opening Height	Head-room	Oblong ML Diameter	Oblong ML Opening Width	Oblong ML Opening Height	
HPLWL-1-48	1	36	2	1.75	25	24	48	53	0.63	3	6	255
HPLWL-2-48	2	36	4	1.75	25	24	48	57	0.63	3	6	435

NOTE: Additional 2"-3" clearance is recommended above the load for ease of loading and unloading the pallet lifter.

*1 US Ton = 2,000 lbs.



HPLLW LIGHTWEIGHT PALLET LIFTER

FEATURES

- This style of lifter is designed to lift and carry palletized loads efficiently with an overhead crane.
- Lightweight design allows for ease of movement to the load and dual lift points allow the lifter to hang level when unloaded.
- Easily maintained low headroom design.
- Engineered and manufactured to ASME B30.20 & BTH-1 Design Category B Service Class 2.
- 100% of ALL pallet lifters are Proof-Tested to 125% capacity and certificates supplied at No Additional Charge.
- Made in USA.

OPTIONS

- Larger throat openings
- Greater outside fork widths
- Additional sizes and capacities available

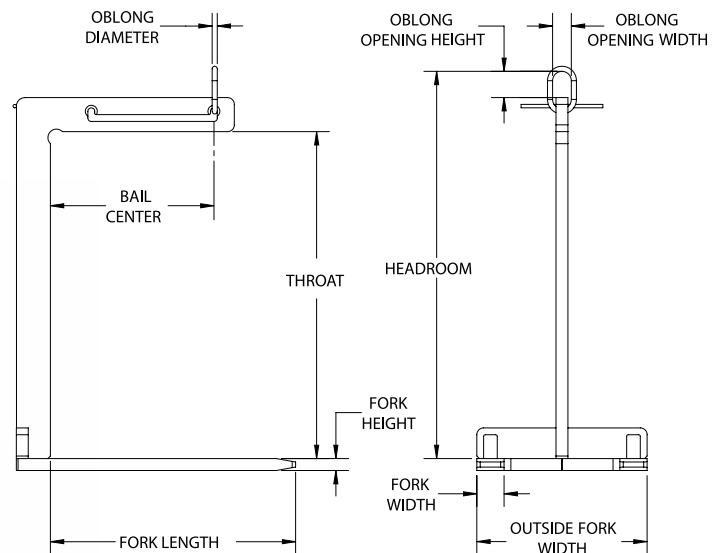
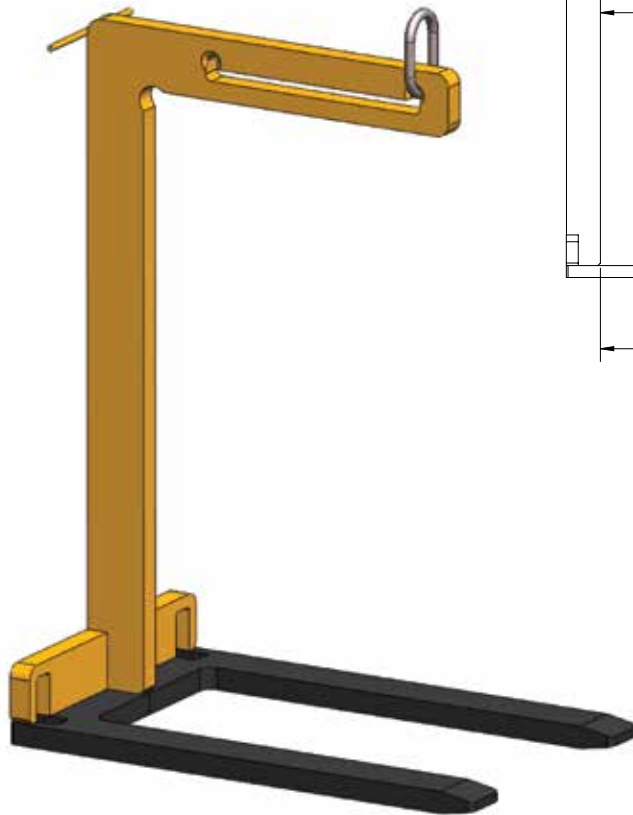

Model #	Capacity (US Tons)*	Dimensions (Inches)										Weight (Lbs.)
		Fork Length	Fork Width	Fork Height	Outside Fork Width	Bail Center	Throat Opening Height	Head-room	Oblong ML Diameter	Oblong ML Opening Width	Oblong ML Opening Height	
HPLLW-1-48	1	36	2	1.75	25	24	48	53	0.63	3	6	245
HPLLW-2-48	2	36	4	1.75	25	24	48	57	0.63	3	6	425
HPLLW-3-48	3	36	5	2	27	24	48	62	1	3.5	7	625

NOTE: Additional 2"-3" clearance is recommended above the load for ease of loading and unloading the pallet lifter.

*1 US Ton = 2,000 lbs.



DO NOT EXCEED CAPACITY!
See the SAFETY GUIDELINES section before using these products. Pages 92-94.

Manual Hoist Products

LB Lever Hoists



CF Hand Chain Hoists



LX Mini Pullers



SHB Ultra-Low Headroom Trolley Hoists



CB Hand Chain Hoists



CX Mini Hand Chain Hoists





HTB
TELESCOPING FORK TRUCK BOOMPage 82

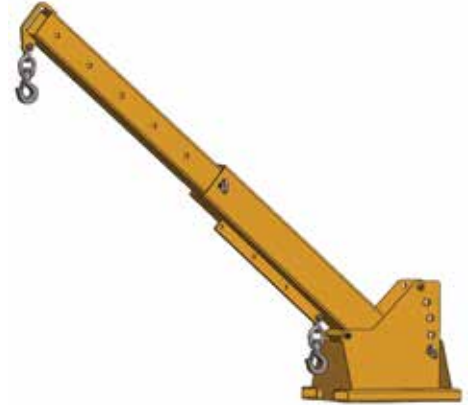

HTBP
TELESCOPING PIVOT FORK TRUCK BOOMPage 83



HFH
FORK TRUCK HOOKPage 84

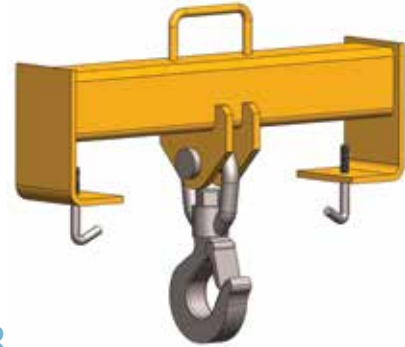

HFHB
FORK TRUCK HOOK BEAMPage 85

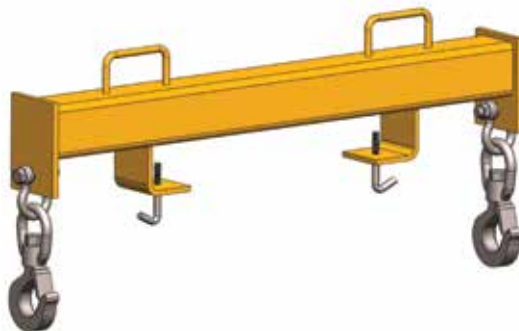

HFHBD
Fork Truck Double Hook BeamPage 86

HTB TELESCOPING FORK TRUCK BOOM

FEATURES

- This style of fork truck attachment is designed to efficiently lift and carry loads with a telescoping boom with locking pin allowing for multiple hook positions.
- Supplied with standard restraining chain with grab hook and attached handle for ease of boom extension.
- 12' maximum boom reach, and supplied with standard swivel or fixed hooks.
- Engineered and manufactured to ASME B30.20 & BTH-1 Design Category B Service Class 2 (where applicable).
- 100% of ALL telescoping fork truck booms are Proof-Tested to 125% capacity and certificates supplied at No Additional Charge.
- Made in USA.

OPTIONS

- Additional sizes and capacities available

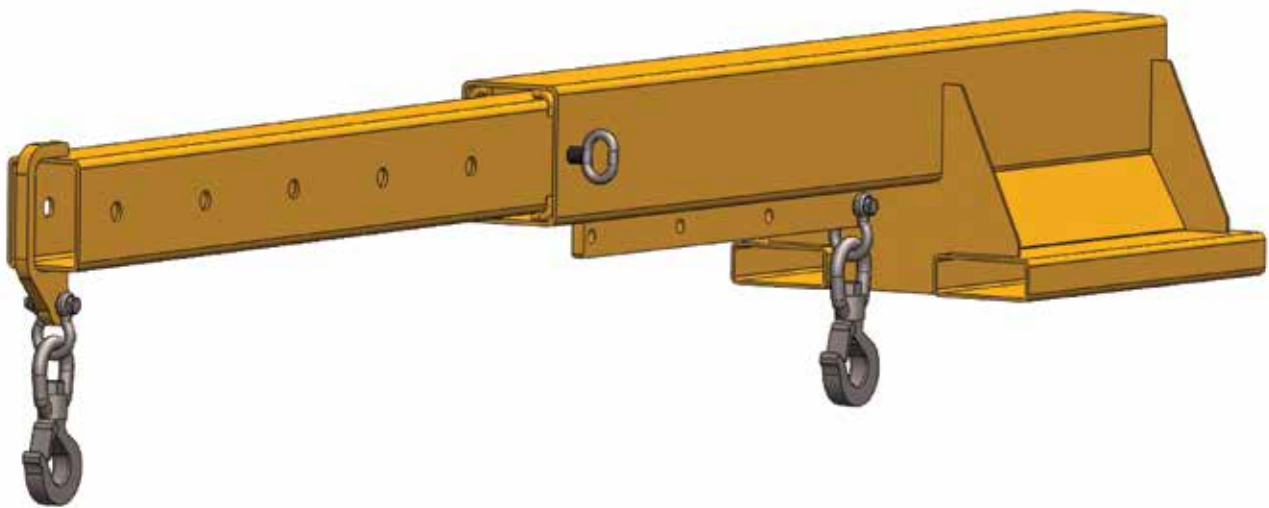
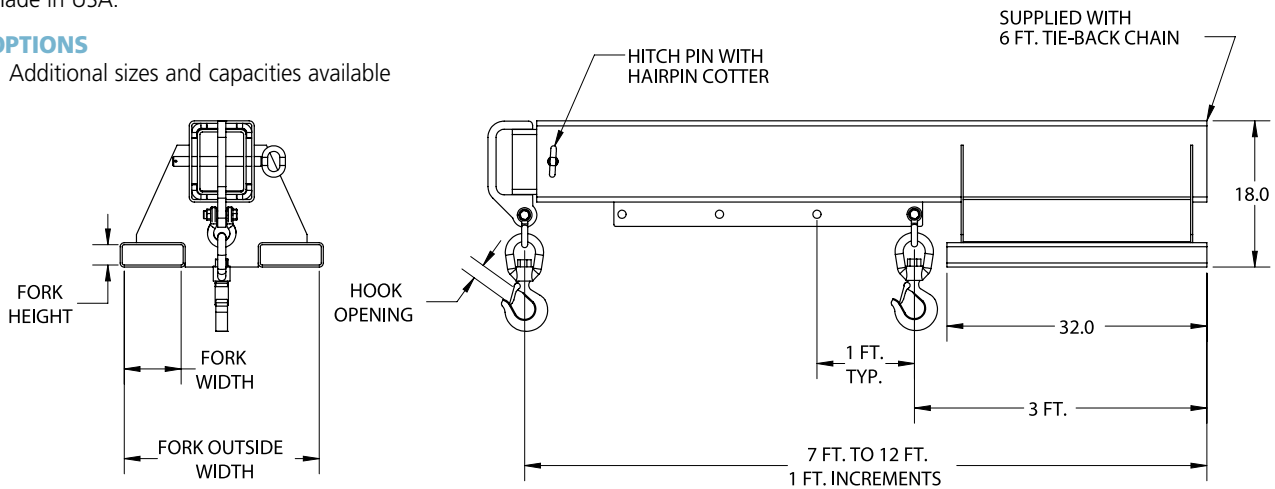

FORK TRUCK ACC.

Model # Fixed	Dimensions (Inches)					Max Capacity at Hook Position (Lbs.)							Weight (Lbs.)
	Fork Opening Height	Fork Opening Width	Fork Outside Width	Headroom	Hook Opening	3' to 6'	7'	8'	9'	10'	11'	12'	
HTB-30	2.5	7	22	18	1	3000	3000	2600	2200	1900	1600	1500	490
HTB-40	2.5	7	22	18	1.09	4000	3200	2600	2200	1900	1600	1500	490
HTB-60	2.5	7	22	18	1.36	6000	5000	4200	3500	3000	2700	2500	565
HTB-80	2.5	7	22	18	1.61	8000	7000	5700	4800	4100	3600	3100	750



WARNING

DO NOT EXCEED CAPACITY!
See the SAFETY GUIDELINES section before using these products. Pages 92-94.

HTBP TELESCOPING PIVOT FORK TRUCK BOOM

FEATURES

- This style of fork truck attachment is designed to efficiently lift and carry loads with a telescoping pivot boom with locking pin allowing for multiple hook positions.
- Supplied with standard restraining chain with grab hook and attached handle for ease of boom extension.
- 12' maximum boom reach, and supplied with standard swivel or fixed hooks and can pivot to a vertical height of 6'4".
- Engineered and manufactured to ASME B30.20 & BTH-1 Design Category B Service Class 2 (where applicable).
- 100% of ALL telescoping pivot fork truck booms are Proof-Tested to 125% capacity and certificates supplied at No Additional Charge.
- Made in USA.

OPTIONS

- Additional sizes and capacities available.

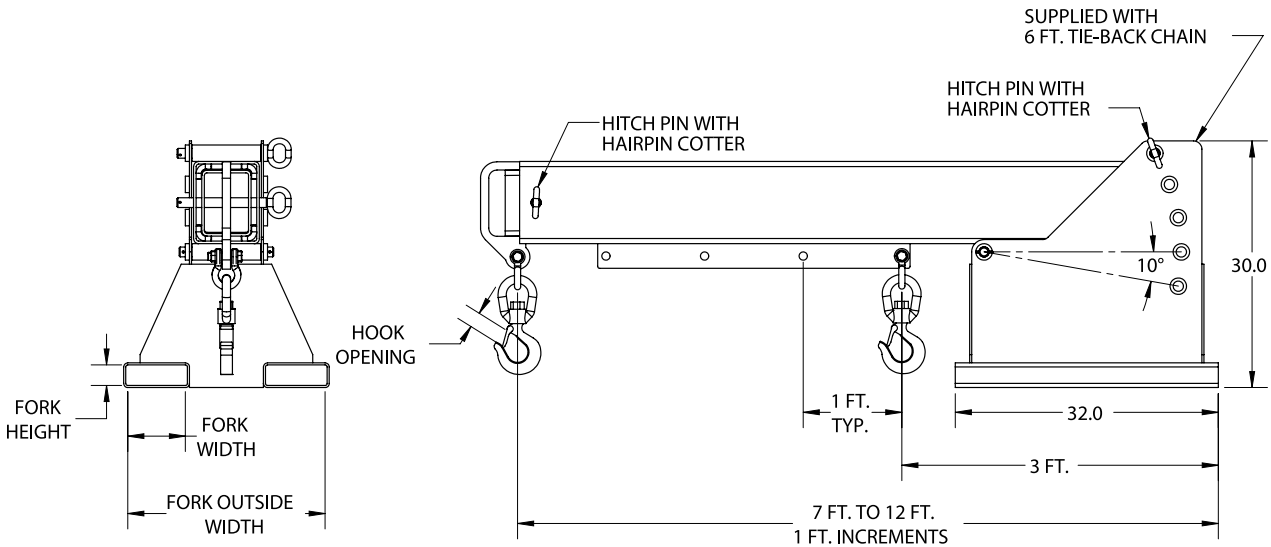
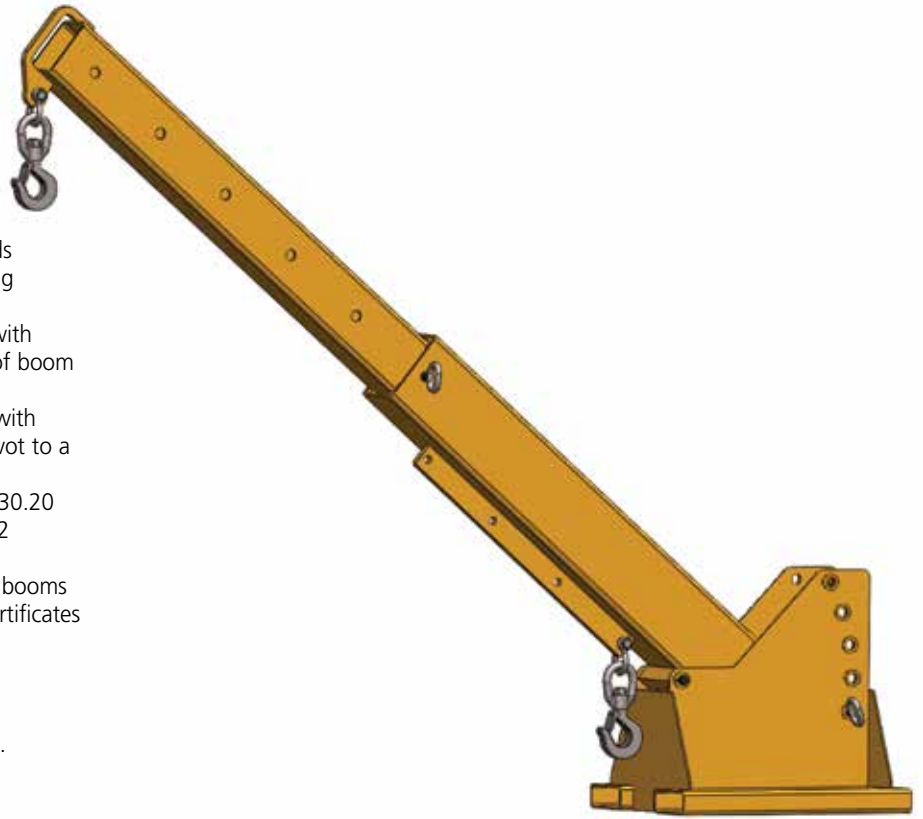

Model # Fixed	Dimensions (Inches)					Max Capacity at Hook Position (Lbs.)							Weight (Lbs.)
	Fork Opening Height	Fork Opening Width	Fork Outside Width	Headroom	Hook Opening	3' to 6'	7'	8'	9'	10'	11'	12'	
HTBP-30	2.5	7	22.5	30	1	3000	3000	2600	2200	1900	1600	1500	565
HTBP-40	2.5	7	22.5	30	1.09	4000	3200	2600	2200	1900	1600	1500	565
HTBP-60	2.5	7	22.5	30	1.36	6000	5000	4200	3500	3000	2700	2500	680
HTBP-80	2.5	7	22.5	30	1.61	8000	7000	5700	4800	4100	3600	3100	870



DO NOT EXCEED CAPACITY!
See the SAFETY GUIDELINES section before using these products. Pages 92–94.

HFH FORK TRUCK HOOK

FEATURES

- This style of fork truck attachment is designed to efficiently lift and carry loads on the fork of a lift truck with a single latched fixed or swivel hook.
- Easily attaches to the forks.
- Engineered and manufactured to ASME B30.20 & BTH-1 Design Category B Service Class 2 (where applicable).
- 100% of ALL fork truck hooks are Proof-Tested to 125% capacity and certificates supplied at No Additional Charge.
- Made in USA.

OPTIONS

- Additional sizes and capacities available

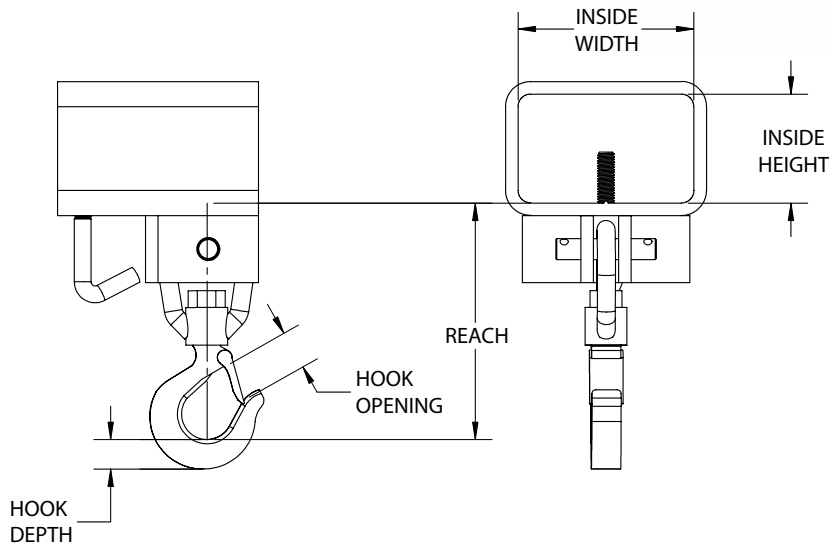
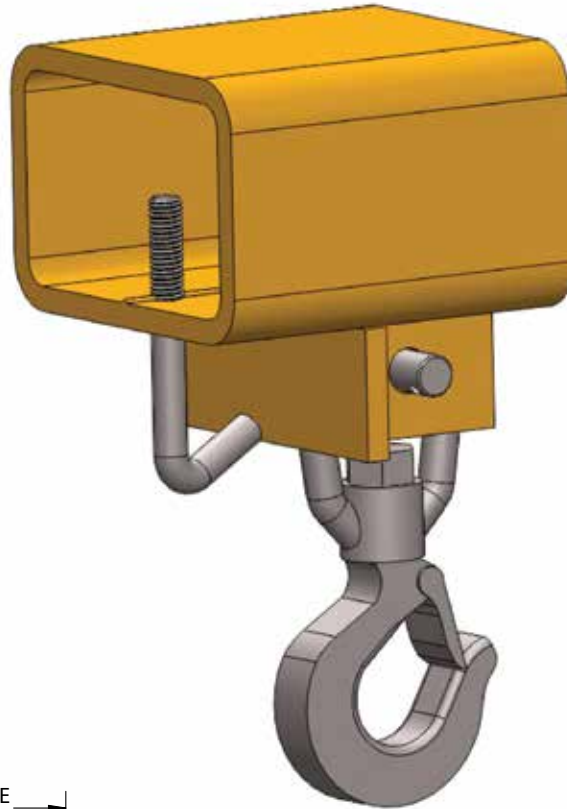

Model # Fixed	Model # Swivel	Capacity (US Tons)*	Dimensions (Inches)						Weight (Lbs.)
			Inside Beam Width	Inside Beam Height	Hook Reach Fixed	Hook Reach Swivel	Hook Depth	Hook Opening	
HFH-1.5-4.5	HFHS-1.5-4.5	1.5	5.25	3.25	4.69	6.56	1	1	17
HFH-1.5-5.5	HFHS-1.5-5.5	1.5	6	3	4.69	6.56	1	1	22
HFH-1.5-6.5	HFHS-1.5-6.5	1.5	7	3	4.69	6.56	1	1	24

*1 US Ton = 2,000 lbs.



HFHB FORK TRUCK HOOK BEAM

FEATURES

- This style of fork truck attachment is designed to efficiently lift and carry loads on both forks of a lift truck with a single latched fixed or swivel hook.
- Easily attaches to the forks.
- Engineered and manufactured to ASME B30.20 & BTH-1 Design Category B Service Class 2 (where applicable).
- 100% of ALL fork truck hooks are Proof-Tested to 125% capacity and certificates supplied at No Additional Charge.
- Made in USA.

OPTIONS

- Additional sizes and capacities available

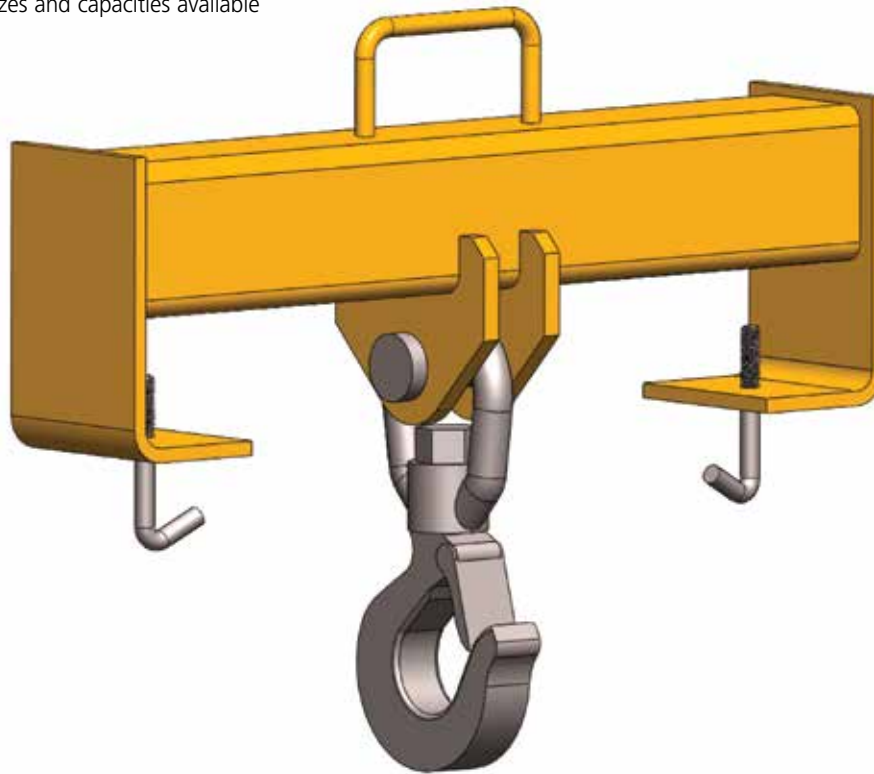
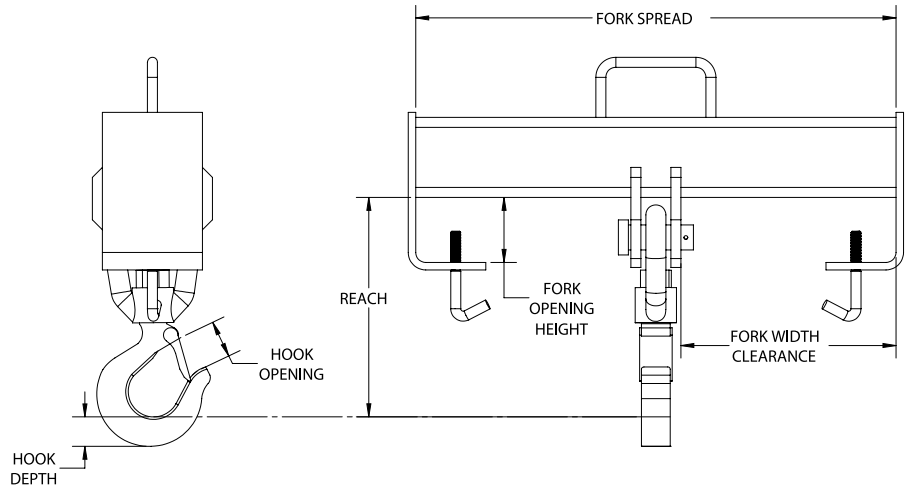

Model # Fixed	Model # Swivel	Dimensions (Inches)								Weight (Lbs.)
		Capacity (US Tons)*	Fork Spread	Fork Opening Height	Fork Width Clearance	Hook Reach Fixed	Hook Reach Swivel	Hook Depth	Hook Opening	
HFHB-2-20	HFHBS-2-20	2	20	3.25	9.13	7.25	8.88	1.13	1.16	25
HFHB-5-24	HFHBS-5-24	5	24	3.25	10.75	9.25	11.44	1.81	1.69	50
HFHB-5-36	HFHBS-5-36	5	36	3.25	16.75	9.25	11.44	1.81	1.69	80
HFHB-7.5-36	HFHBS-7.5-36	7.5	36	4.25	16.25	13.75	15.75	2.25	2.22	175
HFHB-10-36	HFHBS-10-36	10	36	4.25	16	14.63	16.44	2.59	2.41	190
HFHB-15-36	HFHBS-15-36	15	36	4.25	15.88	14.5	16.31	2.59	2.41	220

*1 US Ton = 2,000 lbs.



DO NOT EXCEED CAPACITY!
See the SAFETY GUIDELINES section before using these products. Pages 92–94.

HFHBD

FORK TRUCK DOUBLE HOOK BEAM

FEATURES

- This style of fork truck attachment is designed to efficiently lift and carry loads on both forks of a lift truck with two latched swivel hooks.
- Easily attaches to the forks.
- Engineered and manufactured to ASME B30.20 & BTH-1 Design Category B Service Class 2 (where applicable).
- 100% of ALL fork truck hooks are Proof-Tested to 125% capacity and certificates supplied at No Additional Charge.
- Made in USA.

OPTIONS

- Additional sizes and capacities available

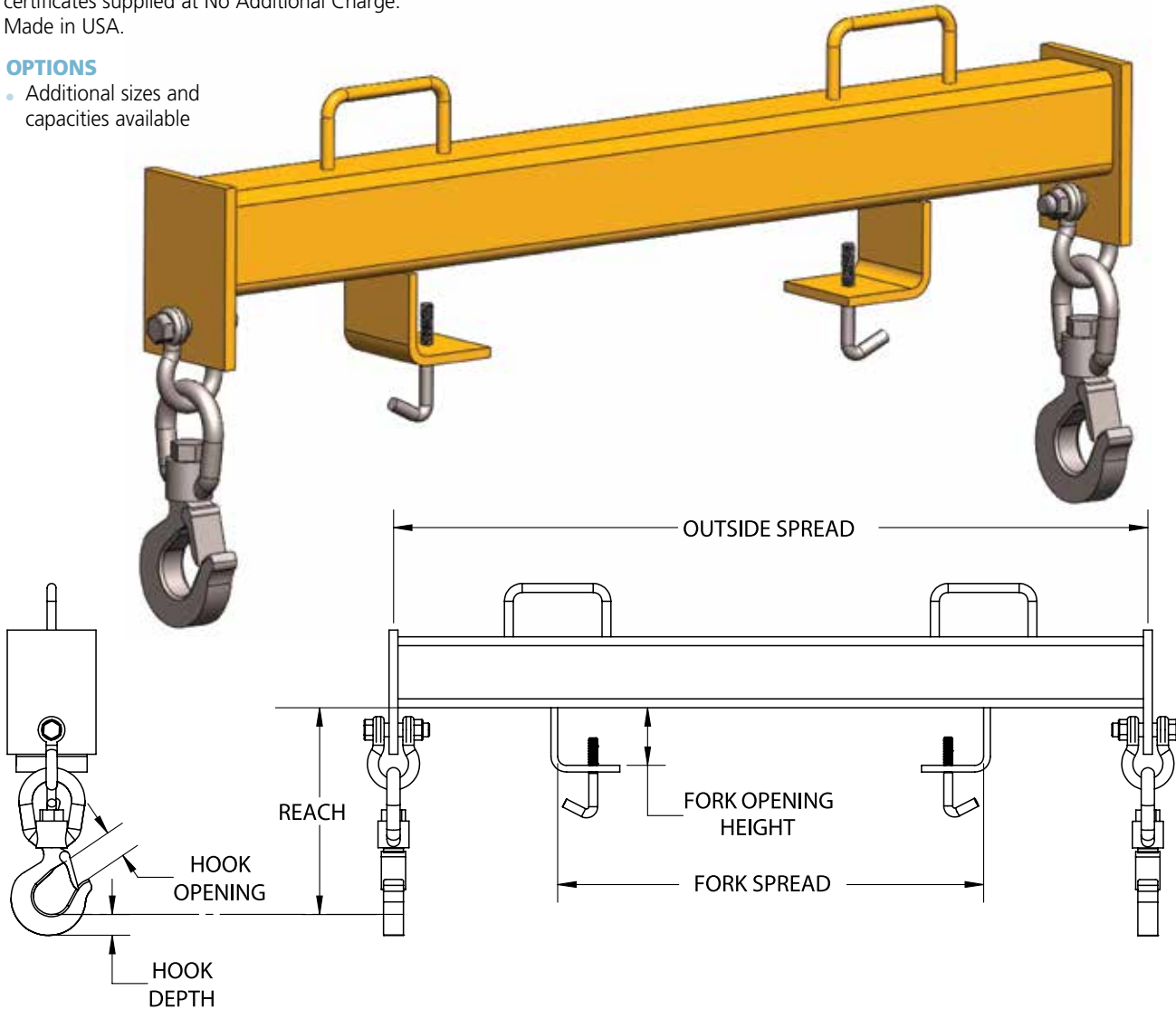

FORK TRUCK ACC.

Model #	Capacity (US Tons)*	Dimensions (Inches)						Weight (Lbs.)
		Outside Beam Spread	Fork Spread	Fork Opening Height	Hook Reach	Hook Depth	Hook Opening	
HFHBD-2-20	2	20	6.63	3.25	10.38	1.44	0.91	66
HFHBD-5-24	5	24	9.38	3.25	11.66	1.44	1.36	75

*1 US Ton = 2,000 lbs.





HMSHD

Material Stands Heavy Duty.....Page 88

HMBHD

Material Baskets Heavy Duty.....Page 90



WARNING

DO NOT EXCEED CAPACITY!
See the SAFETY GUIDELINES section before using these products. Pages 92–94.

HMSHD

MATERIAL STANDS HEAVY DUTY

FEATURES

- This style of material handling equipment is designed to hold product at a preset work height.
- Designed and manufactured in pairs to meet your specific height and capacity requirement.
- Standard heavy duty welded steel design.
- Standard rated capacity labels.
- Engineered and manufactured to ASME B30.20 & BTH-1 Design Category B Service Class 2 (where applicable).
- Made in USA.

OPTIONS

- Fork lift transport pockets
- Spring loaded caster wheels
- Protective padding



MATERIAL STANDS

Custom Application Form



For pricing information: Fax completed form & contact info to 717-665-2861 or email Customer Service at customerservice@harringtonhoists.com

LOAD INFORMATION:

Describe the material you are planning to set on the stands: _____

Does the Material Require Protective Lining to Prevent Damage: Yes No

Is the Material Hot: Yes No

If Yes:

Max Temp _____

Required Contact Time with Material: _____

Min Cool Down Time: _____

Material Dimensions:

	Min (in)	Max (in)
Height	_____	_____
Width	_____	_____
Length	_____	_____
Weight	_____	_____

MATERIAL STAND INFORMATION:

Required Height: _____

Required Width: _____

Required Capacity: _____

Spring Loaded Caster Wheels (specify floor surface): _____

Fork Lift Transport Pockets (specify dimensions):

Length: _____

Width: _____

Height: _____

Please provide pertinent application information not supplied above (*extreme product or operating temperature, extreme environmental conditions such as temperature or moisture, space or headroom restrictions, additional specifications*): _____

HMBHD

MATERIAL BASKETS HEAVY DUTY

FEATURES

- This style of material handling equipment is designed to lift, transport and contain product effectively and efficiently.
- Designed and manufactured to meet your specific application requirements.
- Standard heavy duty welded steel design.
- Standard expanded metal or solid side walls and heavy duty hinged door.
- Standard rated capacity labels.
- Engineered and manufactured to ASME B30.20 & BTH-1 Design Category B Service Class 2 (where applicable).
- 100% of ALL material baskets are Proof-Tested to 125% capacity and certificates supplied at No Additional Charge.
- Made in USA.

OPTIONS

- Fork lift transport pockets
- Caster wheels
- Protective padding
- Chain top rigging
- Wire rope top rigging



MATERIAL BASKETS

Custom Application Form



For pricing information: Fax completed form & contact info to 717-665-2861 or email Customer Service at customerservice@harringtonhoists.com

LOAD INFORMATION:

Describe the material you are planning to place in the basket: _____

Will the Material be placed in the Center of the Basket: Yes No
If No, Please Provide a Drawing or Sketch Indicating the Load Center.

	Min (in)	Max (in)
Height	_____	_____
Width	_____	_____
Length	_____	_____
Weight	_____	_____

Does the Material Require Protective Lining to Prevent Damage: Yes No

MATERIAL BASKET INFORMATION:

Required Wall Height: _____ Width: _____ Depth: _____ Capacity: _____

Door:

Specify Location: End Side

Specify Swing: Right Left

Other: _____

Wall Material:

Solid Expanded Metal Open Frame

Other: _____

Crane Attachment:

Chain Top Rigging Wire Rope Rigging Lifting Beam Lifting Bracket

Caster Wheels (specify floor surface): _____

Fork Lift Transport Pockets (specify dimensions):

Length: _____ Width: _____ Height: _____

Maximum Fork Outside Width: _____

Please provide pertinent application information not supplied above (*extreme product or operating temperature, extreme environmental conditions such as temperature or moisture, space or headroom restrictions, additional specifications*): _____

SAFETY GUIDELINES

INDUSTRY STANDARDS

The American Society of Mechanical Engineers (ASME) developed standards that apply specifically to the devices Harrington Hoists, Inc. designs and manufacturers. These standards serve as a guide to government authorities, manufacturers, purchasers and operators of below-the-hook lifting devices.

ASME B30.20-2018

- Provides detailed information on the classifications, marking, construction, installation, inspection, testing, maintenance and operation of below-the-hook lifting devices.

ASME BTH-1-2017

- Provides detailed information on the design criteria of below-the-hook lifting devices.

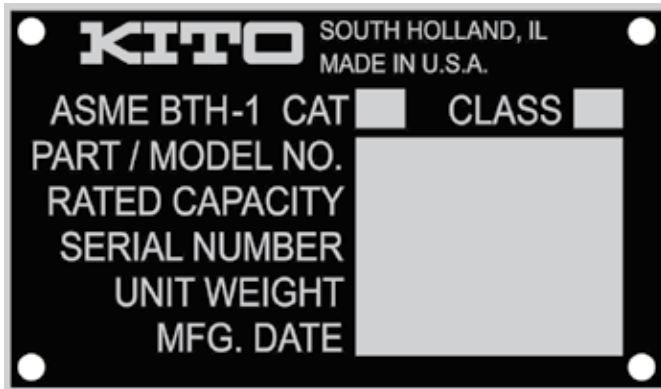

MARKINGS, IDENTIFICATION & GENERAL CONSTRUCTION

The rated load of the lifting device is visibly marked on the main structure of the device, as well as on a tag attached to the lifter. If the below-the-hook lifting device consists of individually detachable lifters, then each of the individual lifters shall be marked and tagged with their individual rated loads.

All Harrington below-the-hook lifting devices are tagged with the following information:

- Manufacturer's name and address
- Serial number
- Lifter weight, if over 100 lbs. (45 kg)
- Cold current (amps) (when applicable)
- Rated voltage (when applicable)
- Rated load
- Manufacture date
- ASME BTH-1 Design category
- ASME BTH-1 Service class

All Harrington structural and mechanical lifting devices are designed and manufactured by qualified personnel. Harrington designs are in accordance with ASME BTH-1 and take into consideration the stresses that result from the application of the rated load along with the weight of the actual lifter and are designed to ASME BTH-1 Design Category B. Service Class is determined by taking into consideration the fatigue life criteria based on the expected number of load cycles.

DESIGN CATEGORY

Design category B shall be utilized when the size, scale, and variation of loads applied to the lifter are not always predictable or clearly defined, and where the environmental and loading conditions vary or could be severe.

SERVICE CLASS

- Service Class is determined by the specified fatigue life of the lifter.
 - Service Class 0 is 0 to 20,000 load cycles.
 - Service Class 1 is 20,001 to 100,000 load cycles.
 - Service Class 2 is 100,001 to 500,000 load cycles.
 - Service Class 3 is 500,001 to 2,000,000 load cycles.
 - Service Class 4 is over 2,000,000 load cycles

SERVICE CLASS LIFE

Cycles Per Day	Desired Life (Years)				
	1	5	10	20	30
5	0	0	0	1	1
10	0	0	1	1	2
25	0	1	1	2	2
50	0	1	2	2	3
100	1	2	2	3	3
200	1	2	3	3	4
300	2	3	3	4	4
750	2	3	4	4	4
1,000	2	3	4	4	4

All welding shall be in accordance with AWS D14.1 /D14M and ASME BTH-1

Exposed moving parts such as gears, projecting shafts and chain drives that constitute a hazard under normal operating conditions are guarded.

Electrical equipment and wiring shall comply with ANSI/NFPA 70 and ASME BTH-1.

FOR INFORMATION ON MODIFICATIONS OR REPAIRS TO YOUR LIFTING DEVICE, CONTACT HARRINGTON HOISTS, INC. TO ENSURE COMPLIANCE WITH THE CURRENT ASME STANDARDS.

PROOF TEST

100% OF ALL HARRINGTON BELOW-THE-HOOK LIFTING DEVICES ARE PROOF-TESTED TO 125% CAPACITY AND CERTIFICATES SUPPLIED AT NO ADDITIONAL CHARGE.

Requirements & Recommendations:

Requirements of the ASME standard are noted by the word **shall**.

Recommendations of the ASME standard are noted by the word **should**.

OPERATION PRACTICES FOR LIFTING DEVICES

Below-the-hook lifting devices shall only be operated by the following qualified personnel:

- Personnel designated to operate the lifter.
- Trainees who are under the direct supervision of designated personnel.
- Personnel designated to maintenance and/or conduct testing on the lifter.
- Personnel designated to inspect the lifter.

The operator shall ensure that the weight of the load to be lifted along with its approximate center of gravity have been provided, calculated, or obtained.

The below-the-hook lifting device shall not be overloaded beyond its manufactured rated capacity nor shall it be utilized to handle any load that it was not designed to handle.

The operator shall ensure the lifting device is properly attached to the hook, shackle, or other load handling device.

The operator shall ensure that the lifter is applied to the load in accordance with the instruction manual.

When rigging is utilized in conjunction with the lifter, the operator shall ensure that it is not kinked and the multiple part lines are not twisted around each other.

The operator shall ensure that the load is correctly distributed for the lifter prior to the lift.

The operator shall ensure that the temperature of the load does not exceed the maximum allowable limits of the lifting device.

The operator shall ensure that the load is properly balanced and well secured with the lifting device at the onset of the lift.

The operator shall ensure that the lifter and the load do not come into contact with any obstruction.

The operator shall ensure that the lifter is sufficiently protected from damage during use.

The operator shall ensure that the lifter is not utilized for side pulls or sliding the load unless explicitly authorized by a qualified person.

Before leaving the lifter the operator shall land any attached load and store the lifter in an assigned location. The operator shall ensure that suspended loads are not left unattended.

The operator shall ensure that no person rides the load or the lifter.

The operation of the lifter shall be observed prior to and during a shift. Any observed deficiency in the lifter shall be examined by designated personnel. Any deficiency that constitutes a hazard shall be removed from service and tagged "Out of Service". All hazardous deficiencies shall be reported to qualified personnel for evaluation.

All loads shall be guided in a manner to avoid endangering any part of the body as it is moved, lowered or if it is accidentally dropped.

Miscellaneous Operating Practices

An operator shall not utilize a below-the-hook lifter that has an "out of service" tag or has been designated as non-functioning.

Only designated personnel shall be given the authority to remove "Out of service" tags on lifting devices.

When not in use the below-the-hook device should be stored in an assigned location.

Lifter markings and tags shall not be removed or damaged. Lifter markings and tags that are missing or illegible shall be replaced.

INSPECTION

Initial Inspection:

Prior to initial use, all new, altered, modified, reinstalled, or repaired lifting devices shall be inspected by a qualified person to ensure compliance with the provisions of the ASME B30.20 standard.

Inspection Intervals:

Below-the-hook lifters in regular service require three general types of inspection classification procedures; every lift, frequent, and periodic. The intervals for inspection are determinant upon the severity of use of the below-the-hook device, the extent of the exposure to wear and tear, as well as any history of malfunction experienced by the lifter.

Every Lift Inspection:

A visual examination performed by the operator of the below-the-hook lifter conducted prior to and during every lift.

cont.

SAFETY GUIDELINES

Frequent Inspection:

Are comprised of visual inspections performed by either the lifter operator or other assigned personnel (records are not required by the ASME standard).

- Normal use – once a month
- Heavy use – once a week to once a monthly
- Severe use – once a day to once a week
- Special or infrequent use – outlined as specified by a qualified individual prior to and following each use.
- Any lifter that has been idle for a period of one month to a year shall undergo a frequent inspection prior to use.

The following items listed below shall be included within the regular inspection schedule and shall be thoroughly inspected and an assessment formed as to the extent of the issue and the level of subsequent hazard resulting from it.

- Structural deformation
- Cracks in welds or structural members
- Excessive wear
 - Loose or missing parts, tags, safety guards, fasteners, stops, and/or housings..
 - Out of adjustment conditions that interfere with the normal operation and functionality of all mechanisms including automatic hold and release components.
 - Unreadable or missing operating control labels.
 - Contact Harrington Hoists, Inc. for replacements of missing identification tags and nameplates.

Periodic Inspections:

Are comprised of visual inspections performed by assigned personnel who record the current condition of the below-the-hook lifter in order to provide the basis for a continuing program of recorded evaluation. Dated reports for periodic inspections shall be maintained.

- Normal use – annual inspection typically performed on-site.
- Heavy use – disassembly by a qualified individual should be performed semi-annually in order to facilitate a detailed inspection.
- Severe use – disassembly by a qualified individual should be performed quarterly in order to facilitate a detailed inspection.
- Special or infrequent use – outlined as specified by a qualified individual prior to and following each use.
- Any lifter that has been idle for a period of one year or more shall undergo a periodic inspection prior to use.

Below-the-hook lifting devices shall undergo a thorough inspection based upon the previously defined intervals of every lift, frequent, and periodic. Any and all issues such as the following (as listed below) shall be investigated and a conclusion made as to if the extent of the issue and to if it is severe enough in its nature to represent a hazard. Dated inspection reports of the following critical items shall be made.

- All requirements outlined within the frequent inspection process.
- Missing or loose nuts, bolts, or fasteners.
- Fractured gears, pulleys, sheaves, sprockets, bearings, chain and belts.
- Excessive wear of linkages, gears, pulleys, sprockets, sheaves, chain, belts, bearings, hardware, and other mechanical parts.
- Excessive wear at the bail or other load bearing points.
- Unreadable or missing product safety labels, as required by ASME B30.20 standard.

All repairs or modifications shall be documented on dated inspection reports.

MAINTENANCE: Preventive Maintenance:

A preventive maintenance program shall be established and be based on recommendations made by Harrington Hoists, Inc. It can be determined to be appropriate as designated by a qualified person to add to the maintenance program following a review of the use of the below-the-hook lifter.

Any hazards disclosed during an inspection shall be corrected before the lifting device is put back into service. Any repairs and/or adjustments shall be done only under the direction of or by a qualified person. Replacement parts shall be equivalent to the Harrington Hoists, Inc.'s specifications.

For more information or to purchase a copy of the standard, visit ASME website, www.ASME.org.

Notes

A

ADJUSTABLE BAIL LIFTING BEAM	19-21
ADJUSTABLE LIFTING BEAM	18
ADJUSTABLE FORK HEAVY DUTY PALLET LIFTER.....	76
ADJUSTABLE FORK HEAVY DUTY PALLET LIFTER (w/HAND WHEEL)	77
ADJUSTABLE FORK PALLET LIFTER	73
ADJUSTABLE FORK PALLET LIFTER (w/HAND WHEEL)	74
ADJUSTABLE TELESCOPIC SPREADER BEAM.....	34

B

BAR TONG ADJUSTABLE	63
BAR TONG FIXED	62
BASKET SLING LIFTING BEAM	12-14
BOX SPREADER BEAM	35

C

CHLORINE GAS CYLINDER LIFTING BEAM.....	29
COIL GRAB VERTICAL	56
COIL LIFTER	51
COIL LIFTERS	50-58
COIL GRAB VERTICAL	56
COIL LIFTER	51
COIL LIFTER NARROW COIL	50
COIL LIFTER CLOSE STACKING.....	52
COIL LIFTER SLIT COIL.....	53
COIL LIFTER TELESCOPIC TWO SIDED.....	57
COIL LIFTER VERTICAL.....	54
COIL LIFTER VERTICAL WIDE.....	55
NARROW ARM COIL LIFTER.....	58
COIL LIFTER NARROW COIL.....	50
COIL LIFTER CLOSE STACKING	52
COIL LIFTER SLIT COIL	53
COIL LIFTER TELESCOPIC TWO-SIDED	57
COIL LIFTER VERTICAL	54
COIL LIFTER VERTICAL WIDE	55
CUSTOM APPLICATION FORM.....	30, 42, 48, 59, 64, 69, 89, 91
COIL LIFTER.....	59
LIFTING BEAMS	30
MATERIAL BASKETS	91
MATERIAL STANDS	89
ROLL LIFTER	48
SHEET LIFTER	69
SPREADER BEAMS.....	42
TONG.....	64

D

DUAL CRANE LIFTING BEAM	15-16
DUAL CRANE ROTATING BEAM.....	28

E

END CAP.....	40
END CAP PIPE.....	40-41
END CAP SPREADER BEAM	36-39

F

FIXED FORK HEAVY DUTY PALLET LIFTER.....	75
FIXED FORK PALLET LIFTER	72
FORK TRUCK ACCESSORIES	82-86
FORK TRUCK DOUBLE HOOK BEAM.....	86
FORK TRUCK HOOK	84
FORK TRUCK HOOK BEAM.....	85
TELESCOPIC FORK TRUCK BOOM.....	82
TELESCOPIC PIVOT FORK TRUCK BOOM.....	83
FORK TRUCK DOUBLE HOOK BEAM	86
FORK TRUCK HOOK	84
FORK TRUCK HOOK BEAM	85
FOUR POINT ADJUSTABLE BEAM.....	27
FOUR POINT LIFTING BEAM.....	25
FOUR POINT SACK LIFTING BEAM	26

GHIJK

L

LIFTING BEAMS.....	04-29
ADJUSTABLE BAIL LIFTING BEAM	19-21
ADJUSTABLE LIFTING BEAM	18
BASKET SLING LIFTING BEAM.....	12-14
CHLORINE GAS CYLINDER LIFTING BEAM	29
DUAL CRANE LIFTING BEAM.....	15-16
DUAL CRANE ROTATING BEAM	28
FOUR POINT ADJUSTABLE BEAM	27
FOUR POINT LIFTING BEAM	25
FOUR POINT SACK LIFTER BEAM	26
LOAD LEVELING BEAM	22-23
SHORT SPAN LIFTING BEAM.....	04-05
STANDARD DUTY LIFTING BEAM (CHANNEL DESIGN).....	06-08
STANDARD DUTY LIFTING BEAM (I-BEAM DESIGN w/ FLAME CUT BAIL).....	09-10
STANDARD DUTY LIFTING BEAM (I-BEAM DESIGN w/PIN BAIL).....	11
THREE POINT LIFTING BEAM.....	24
UNIVERSAL LIFTING/SPREADER BEAM.....	17
LIGHTWEIGHT PALLET LIFTER	79
LOAD LEVELING BEAM	22-23

M

MATERIAL BASKETS HEAVY DUTY.....	90
MATERIAL HANDLING.....	88-90
MATERIAL BASKETS HEAVY DUTY	90
MATERIAL STANDS HEAVY DUTY	88
MATERIAL STANDS HEAVY DUTY.....	88
MOTORIZED ROLL LIFTER	45
MOTORIZED SHEET LIFTER HEAVY DUTY	67

N

NARROW ARM COIL LIFTER	58
------------------------------	----

O

P

PALLET LIFTERS.....	72-79
ADJUSTABLE FORK HEAVY DUTY PALLET LIFTER.....	76
ADJUSTABLE FORK HEAVY DUTY PALLET LIFTER (w/HAND WHEEL).....	77
ADJUSTABLE FORK PALLET LIFTER	73
ADJUSTABLE FORK PALLET LIFTER (w/HAND WHEEL).....	74
FIXED FORK HEAVY DUTY PALLET LIFTER	75
FIXED FORK PALLET LIFTER	72
LIGHTWEIGHT PALLET LIFTER.....	79
WHEELED PALLET LIFTER	78

Q

R

ROLL LIFTERS	44-47
MOTORIZED ROLL LIFTER	45
ROLL GRIPPING TONGS	46
ROLL LIFTING BEAM	44
ROLL LIFTING C-HOOK	47
ROLL GRIPPING TONGS.....	46
ROLL LIFTING BEAM.....	44
ROLL LIFTING C-HOOK.....	47

S

SAFETY GUIDELINES.....	92-94
SHEET LIFTERS	66-68
MOTORIZED SHEET LIFTER HEAVY DUTY	67
SHEET LIFTER HEAVY DUTY	66
SHEET LIFTER LIGHT DUTY.....	68
SHEET LIFTER HEAVY DUTY.....	66
SHEET LIFTER LIGHT DUTY	68
SHORT SPAN LIFTING BEAM	04-05
SPREADER BEAMS.....	31-41
ADJUSTABLE TELESCOPIC SPREADER BEAM	34
BOX SPREADER BEAM.....	35
END CAP SPREADER BEAM.....	36-41
STANDARD DUTY SPREADER BEAM	32-33
STANDARD DUTY LIFTING BEAM (CHANNEL DESIGN)	06-08
STANDARD DUTY LIFTING BEAM (I-BEAM DESIGN w/FLAME CUT BAIL)	09-10
STANDARD DUTY LIFTING BEAM (I-BEAM DESIGN w/PIN BAIL)	11
STANDARD DUTY SPREADER BEAM	32-33

T

TELESCOPIC FORK TRUCK BOOM.....	82
TELESCOPIC PIVOT FORK TRUCK BOOM	83
THREE POINT LIFTING BEAM.....	24
TONGS.....	62-63
BAR TONG ADJUSTABLE.....	62
BAR TONG FIXED.....	63

U

UNIVERSAL LIFTING/SPREADER BEAM	17
---------------------------------------	----

V

W

WHEELED PALLET LIFTER	78
-----------------------------	----

XYZ

PART NUMBER INDEX

HECSB-70-36 38
 HECSB-70-40 38
 HECSB-70-8 38
 HECSB-80-10 38
 HECSB-80-12 38
 HECSB-80-16 38
 HECSB-80-20 38
 HECSB-80-24 38
 HECSB-80-28 38
 HECSB-80-32 38
 HECSB-80-36 38
 HECSB-80-40 38
 HECSB-80-8 38
 HECSB-90-10 39
 HECSB-90-12 39
 HECSB-90-16 39
 HECSB-90-20 39
 HECSB-90-24 39
 HECSB-90-28 39
 HECSB-90-32 39
 HECSB-90-36 39
 HECSB-90-40 39
 HECSB-90-8 39
 HFFH-1-5-4-5 84
 HFFH-1-5-5-5 84
 HFFH-1-5-6-5 84
 HFFHB-10-36 85
 HFFHB-15-36 85
 HFFHB-2-20 85
 HFFHB-5-24 85
 HFFHB-5-36 85
 HFFHB-7-5-36 85
 HFFHBD-2-20 86
 HFFHBD-5-24 86
 HFFHBS-10-36 85
 HFFHBS-15-36 85
 HFFHBS-2-20 85
 HFFHBS-5-24 85
 HFFHBS-5-36 85
 HFFHBS-7-5-36 85
 HFFHS-1-5-4-5 84
 HFFHS-1-5-5-5 84
 HFFHS-1-5-6-5 84
 HFFPAB-10-144/96 27
 HFFPAB-3-84/60 27
 HFFPAB-5-120/96 27
 HFFPSL-1-365K 26
 HFFPSL-1-485K 26
 HFFPSL-2-365K 26
 HFFPSL-2-485K 26
 HLLB-10-10 22
 HLLB-10-12 22
 HLLB-10-14 22
 HLLB-10-16 22
 HLLB-10-18 22
 HLLB-10-20 22
 HLLB-10-24 22
 HLLB-10-4 22
 HLLB-10-6 22
 HLLB-10-8 22
 HLLB-15-10 22
 HLLB-15-12 22
 HLLB-15-14 22
 HLLB-15-16 22
 HLLB-15-18 22
 HLLB-15-20 22
 HLLB-15-24 22
 HLLB-15-4 22
 HLLB-15-6 22
 HLLB-15-8 22
 HLLB-20-10 22
 HLLB-20-12 22
 HLLB-20-14 22
 HLLB-20-16 22
 HLLB-20-18 22
 HLLB-20-20 22
 HLLB-20-24 22
 HLLB-20-4 22
 HLLB-20-6 22
 HLLB-20-8 22
 HLLB-2-10 22
 HLLB-2-12 22
 HLLB-2-14 22
 HLLB-2-16 22
 HLLB-2-18 22
 HLLB-2-20 22
 HLLB-2-24 22
 HLLB-2-4 22
 HLLB-2-6 22
 HLLB-2-8 22
 HLLB-5-10 22
 HLLB-5-12 22
 HLLB-5-14 22
 HLLB-5-16 22
 HLLB-5-18 22
 HLLB-5-20 22
 HLLB-5-24 22
 HLLB-5-4 22
 HLLB-5-6 22
 HLLB-5-8 22
 HMSLHD-10-48 67
 HMSLHD-10-60 67
 HMSLHD-10-72 67
 HMSLHD-10-84 67
 HMSLHD-10-96 67
 HMSLHD-15-48 67
 HMSLHD-15-60 67

HMSLHD-15-60 67
 HMSLHD-15-72 67
 HMSLHD-15-84 67
 HMSLHD-15-96 67
 HMSLHD-20-48 67
 HMSLHD-20-60 67
 HMSLHD-20-72 67
 HMSLHD-20-84 67
 HMSLHD-20-96 67
 HMSLHD-3-48 67
 HMSLHD-3-60 67
 HMSLHD-3-72 67
 HMSLHD-5-48 67
 HMSLHD-5-60 67
 HMSLHD-5-72 67
 HMSLHD-5-84 67
 HMSLHD-5-96 67
 HNACL-10-48 58
 HNACL-15-48 58
 HNACL-20-60 58
 HNACL-25-60 58
 HNACL-30-72 58
 HPL-1-5-36 72
 HPL-1-5-42 72
 HPL-1-5-48 72
 HPL-1-36 72
 HPL-1-42 72
 HPL-1-48 72
 HPL-2-36 72
 HPL-2-42 72
 HPL-2-48 72
 HPL-3-42 72
 HPL-3-48 72
 HPL-3-54 72
 HPL-4-48 72
 HPL-4-60 72
 HPL-5-48 72
 HPL-5-60 72
 HPLAF-1-5-36 73
 HPLAF-1-5-42 73
 HPLAF-1-5-48 73
 HPLAF-1-36 73
 HPLAF-1-42 73
 HPLAF-1-48 73
 HPLAF-2-36 73
 HPLAF-2-42 73
 HPLAF-2-48 73
 HPLAF-3-42 73
 HPLAF-3-48 73
 HPLAF-3-54 73
 HPLAF-4-48 73
 HPLAF-4-60 73
 HPLAF-5-48 73
 HPLAF-5-60 73
 HPLAH-10-48 77
 HPLAH-10-60 77
 HPLAH-10-72 77
 HPLAH-12-5-48 77
 HPLAH-12-5-60 77
 HPLAH-12-5-72 77
 HPLAH-15-60 77
 HPLAH-15-72 77
 HPLAH-7-5-48 77
 HPLAH-7-5-60 77
 HPLAH-7-5-72 77
 HPLHA-10-48 76
 HPLHA-10-60 76
 HPLHA-10-72 76
 HPLHA-12-5-48 76
 HPLHA-12-5-60 76
 HPLHA-12-5-72 76
 HPLHA-7-5-48 76
 HPLHA-7-5-60 76
 HPLHA-7-5-72 76
 HPLHD-10-48 75
 HPLHD-10-60 75
 HPLHD-15-48 75
 HPLHD-15-60 75
 HPLHD-20-60 75
 HPLHD-20-72 75
 HPLHD-7-5-48 75
 HPLHD-7-5-60 75
 HPLHW-1-5-36 74
 HPLHW-1-5-42 74
 HPLHW-1-5-48 74
 HPLHW-1-36 74
 HPLHW-1-42 74
 HPLHW-1-48 74
 HPLHW-2-36 74
 HPLHW-2-42 74
 HPLHW-2-48 74
 HPLHW-3-42 74
 HPLHW-3-48 74
 HPLHW-3-54 74
 HPLHW-4-48 74
 HPLHW-4-60 74
 HPLHW-5-48 74
 HPLHW-5-60 74
 HPLLW-1-48 79
 HPLLW-2-48 79
 HPLLW-3-48 79
 HPLWL-1-48 78
 HPLWL-2-48 78
 HSDLB-1/2-10 6
 HSDLB-1/2-12 6
 HSDLB-1/2-14 6

HSDLB-1/2-16 6
 HSDLB-1/2-18 6
 HSDLB-1/2-20 6
 HSDLB-1/2-24 6
 HSDLB-1/2-3 6
 HSDLB-1/2-30 6
 HSDLB-1/2-4 6
 HSDLB-1/2-6 6
 HSDLB-1/2-8 6
 HSDLB-10-10 7
 HSDLB-10-12 7
 HSDLB-10-14 7
 HSDLB-10-16 7
 HSDLB-10-18 7
 HSDLB-10-20 10
 HSDLB-10-24 10
 HSDLB-10-3 7
 HSDLB-10-30 10
 HSDLB-10-34 10
 HSDLB-10-38 10
 HSDLB-10-4 7
 HSDLB-10-42 10
 HSDLB-10-6 7
 HSDLB-10-8 7
 HSDLB-1-10 6
 HSDLB-1-12 6
 HSDLB-1-14 6
 HSDLB-1-16 6
 HSDLB-1-18 6
 HSDLB-1-20 6
 HSDLB-1-24 6
 HSDLB-1-3 6
 HSDLB-1-30 6
 HSDLB-1-34 6
 HSDLB-1-38 6
 HSDLB-1-4 6
 HSDLB-1-42 6
 HSDLB-15-10 9
 HSDLB-15-12 8
 HSDLB-15-14 8
 HSDLB-15-16 10
 HSDLB-15-18 10
 HSDLB-15-20 10
 HSDLB-15-24 10
 HSDLB-15-30 10
 HSDLB-15-34 10
 HSDLB-15-38 10
 HSDLB-15-4 8
 HSDLB-15-42 10
 HSDLB-15-6 8
 HSDLB-1-8 6
 HSDLB-20-10 8
 HSDLB-20-12 8
 HSDLB-20-14 10
 HSDLB-20-16 10
 HSDLB-20-18 10
 HSDLB-20-20 10
 HSDLB-20-24 10
 HSDLB-20-3 8
 HSDLB-20-30 10
 HSDLB-20-34 10
 HSDLB-20-38 10
 HSDLB-20-4 8
 HSDLB-20-42 10
 HSDLB-20-6 8
 HSDLB-20-8 8
 HSDLB-2-10 7
 HSDLB-2-12 7
 HSDLB-2-14 7
 HSDLB-2-16 7
 HSDLB-2-18 7
 HSDLB-2-20 7
 HSDLB-2-24 7
 HSDLB-2-3 9
 HSDLB-2-30 9
 HSDLB-2-34 9
 HSDLB-2-38 9
 HSDLB-2-4 9
 HSDLB-2-42 9
 HSDLB-2-5-10 8
 HSDLB-2-5-12 8
 HSDLB-2-5-14 10
 HSDLB-2-5-16 10
 HSDLB-2-5-18 10
 HSDLB-2-5-20 10
 HSDLB-2-5-24 10
 HSDLB-2-5-3 9
 HSDLB-2-5-30 9
 HSDLB-2-5-34 9
 HSDLB-2-5-38 9
 HSDLB-2-5-4 9
 HSDLB-2-5-42 9
 HSDLB-2-5-6 7
 HSDLB-2-5-8 7
 HSDLB-2-5-10 11
 HSDLB-2-5-15 11
 HSDLB-2-5-20 11
 HSDLB-7-5-10 7
 HSDLB-7-5-12 7
 HSDLB-7-5-14 7
 HSDLB-7-5-16 7
 HSDLB-7-5-18 7
 HSDLB-7-5-20 9
 HSDLB-7-5-24 9
 HSDLB-7-5-3 9
 HSDLB-7-5-30 9
 HSDLB-7-5-34 9
 HSDLB-7-5-38 9
 HSDLB-7-5-4 7
 HSDLB-7-5-42 9
 HSDLB-7-5-6 7
 HSDLB-7-5-8 7
 HSDLB-80-10 11
 HSDLB-80-15 11
 HSDLB-80-20 11
 HSDSB-10-10 32
 HSDSB-10-12 32
 HSDSB-10-16 32
 HSDSB-10-20 32
 HSDSB-10-24 32
 HSDSB-10-4 32
 HSDSB-10-6 32
 HSDSB-10-8 32
 HSDSB-15-10 33
 HSDSB-15-12 33
 HSDSB-15-16 33
 HSDSB-15-20 33
 HSDSB-15-24 33
 HSDSB-15-4 32
 HSDSB-15-6 32
 HSDSB-15-8 33
 HSDSB-20-10 33
 HSDSB-20-12 33
 HSDSB-20-16 33
 HSDSB-20-20 33
 HSDSB-20-24 33
 HSDSB-20-4 33
 HSDSB-20-6 33
 HSDSB-20-8 33
 HSDSB-2-10 32
 HSDSB-2-12 32
 HSDSB-2-16 32
 HSDSB-2-20 32
 HSDSB-2-24 32
 HSDSB-2-4 32
 HSDSB-2-6 32

HSDSB-30-10 33
 HSDSB-30-12 33
 HSDSB-30-16 33
 HSDSB-30-20 33
 HSDSB-30-6 33
 HSDSB-30-8 33
 HSDSB-40-10 33
 HSDSB-40-12 33
 HSDSB-40-16 33
 HSDSB-40-6 33
 HSDSB-5-10 32
 HSDSB-5-12 32
 HSDSB-5-16 32
 HSDSB-5-20 32
 HSDSB-5-24 32
 HSDSB-5-4 32
 HSDSB-5-6 32
 HSDSB-5-8 32
 HSLHD-10-48 66
 HSLHD-10-60 66
 HSLHD-10-72 66
 HSLHD-10-84 66
 HSLHD-10-96 66
 HSLHD-15-48 66
 HSLHD-15-60 66
 HSLHD-15-72 66
 HSLHD-15-84 66
 HSLHD-15-96 66
 HSLHD-20-48 66
 HSLHD-20-60 66
 HSLHD-20-72 66
 HSLHD-20-84 66
 HSLHD-20-96 66
 HSLHD-3-48 66
 HSLHD-3-60 66
 HSLHD-3-72 66
 HSLHD-5-48 66
 HSLHD-5-60 66
 HSLHD-5-72 66
 HSLHD-5-84 66
 HSLHD-5-96 66
 HSLLD-1-5-36 68
 HSLLD-1-5-48 68
 HSLLD-3-48 68
 HSLLD-3-60 68
 HSLLD-5-48 68
 HSLLD-5-60 68
 HSSLB-25-1 5
 HSSLB-25-2 5
 HSSLB-25-3 5
 HSSLB-10-3 5
 HSSLB-10-3 5
 HSSLB-1-1 5
 HSSLB-110-2 5
 HSSLB-110-3 5
 HSSLB-1-2 5
 HSSLB-1-3 5
 HSSLB-149-2 5
 HSSLB-149-3 5
 HSSLB-170-2 5
 HSSLB-170-3 5
 HSSLB-195-2 5
 HSSLB-195-3 5
 HSSLB-20-2 5
 HSSLB-20-3 5
 HSSLB-3-1 5
 HSSLB-3-2 5
 HSSLB-3-3 5
 HSSLB-40-2 5
 HSSLB-40-3 5
 HSSLB-50-2 5
 HSSLB-50-3 5
 HSSLB-70-2 5
 HSSLB-70-3 5
 HTB-30 82
 HTB-40 82
 HTB-60 82
 HTB-80 82
 HTBP-30 83
 HTBP-40 83
 HTBP-60 83
 HTBP-80 83
 HUNVB-1/2-10 17
 HUNVB-1/2-4 17
 HUNVB-1/2-6 17
 HUNVB-1/2-8 17
 HUNVB-1/4-4 17
 HUNVB-1-10 17
 HUNVB-1-6 17
 HUNVB-1-8 17
 HUNVB-2-10 17
 HUNVB-2-6 17
 HUNVB-2-8 17
 HUNVB-4-10 17
 HUNVB-4-12 17
 HUNVB-4-8 17
 HUNVB-5-10 17
 HUNVB-5-12 17
 HUNVB-5-8 17
 HUNVB-7-12 17

Complete Product Offering

Over the years Harrington has continued to respond to the needs of our customers by further expanding our product offerings. In addition to the many models described in this catalog, our full series of product catalogs, as shown below, will provide you with all of the information you will need to answer questions, specify a product and place an order. For catalog copies or answers to specific product questions, please contact our Customer Service Department by calling 800-233-3010 or e-mail customerservice@harringtonhoists.com

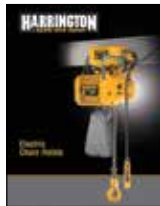

Electric Powered Hoists Catalog

Refer to this Harrington catalog for detailed information on the following:

- Three phase electric hoists and trolleys
- Single phase electric hoists and trolleys
- Ergonomic electric hoists

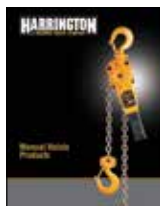

Manual Hoist Products Catalog

Refer to this Harrington catalog for detailed information on the following:

- Lever hoists
- Hand chain hoists
- Hoist and trolley combinations
- Low headroom trolley hoists
- Push and geared trolleys
- Hoist load testers



Air Powered Hoists Catalog

Refer to this Harrington catalog for detailed information on the following:

- Compact Mini-Cat with pendant, cord and manipulator controls
- Air hoists with pendant and cord controls
- Air trolleys



Crane Components Catalog

Refer to this Harrington catalog for detailed information on the following:

- End trucks-top running-motorized, geared and push
- End trucks-underhung-motorized, geared and push
- Double girder MAX-E-Lift end trucks
- Convertible push end trucks
- Beam accessory kits

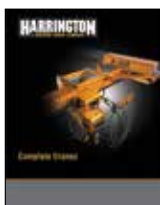

Complete Cranes Catalog

Refer to this Harrington catalog for detailed information on the following:

- Heavy-duty Class C single girder top running and underhung cranes
- Heavy-duty Class C double girder top running and underhung cranes
- Medium-duty top running and underhung push cranes
- Crane control panels



Tiger Track Jib and Gantry Cranes Catalog

Refer to this Harrington catalog for detailed information on the following:

- Light-Duty Base Plate Mounted and Foundationless Jib Cranes
- Heavy-Duty Pillar Base Mounted Jib Cranes
- Motorized Jib Cranes
- Wall Bracket Tie Rod and Cantilever Jib Cranes
- Mast Type Jib Cranes Full Cantilever or Drop Cantilever
- Portable Rigid and Adjustable Gantry Cranes

CONTACT YOUR NEARBY HARRINGTON DISTRIBUTOR

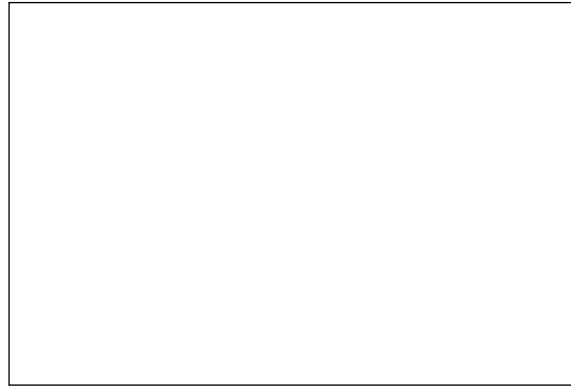

Warranty

All products sold by Harrington Hoists, Inc. are warranted to be free from defects in material and workmanship from date of shipment by Harrington for the following periods:

- 1 year—Electric and Air Powered Hoists (excluding (N)ER2 Enhanced Features Models, EQ/SEQ Hoists), Powered Trolleys, Powered Tiger Track Jibs and Gantries, Crane Components, Sling Chain, Spare/Replacement Parts, Below-The-Hook and Material Handling Equipment**
- 2 years—Manual Hoists & Trolleys, Beam Clamps**
- 3 years—(N)ER2 Enhanced Features Model Hoists, EQ/SEQ Hoists, RY Wire Rope Trolley Hoist**
- 5 years—Manual Tiger Track Jibs and Gantries, TNER and EQ/SEQ and RY Pull-Rotor Motor Brake**
- 10 years—(N)ER2 “The Guardian” Smart Brake**

The product must be used in accordance with manufacturer’s recommendations and must not have been subject to abuse, lack of maintenance, misuse, negligence, or unauthorized repairs or alterations.

Should any defect in material or workmanship occur during the above time period in any product, as determined by Harrington Hoist’s inspection of the product, Harrington Hoists, Inc. agrees, at its discretion, either to replace (not including installation) or repair the part or product free of charge and deliver said item F.O.B. Harrington Hoists, Inc. place of business to customer.

Customer must obtain a Return Goods Authorization as directed by Harrington or Harrington’s published repair center prior to shipping product for warranty evaluation. An explanation of the complaint must accompany the product. Product must be returned freight prepaid. Upon repair, the product will be covered for the remainder of the original warranty period. Replacement parts installed after the original warranty period will only be eligible for replacement (not including installation) for a period of one year from the installation date. If it is determined there is no defect, or that the defect resulted from causes not within the scope of Harrington’s warranty, the customer will be responsible for the costs of returning the product.

Harrington Hoists, Inc. disclaims any and all other warranties of any kind expressed or implied as to the product’s merchantability or fitness for a particular application. Harrington will not be liable for death, injuries to persons or property or for incidental, contingent, special or consequential damages, loss or expense arising in connection with the use or inability whatever, regardless of whether damage, loss or expense results from any act or failure to act by Harrington, whether negligent or willful, or from any other reason.

Harrington Hoists, Inc.
401 West End Avenue
Manheim, PA 17545



Toll Free: 800-233-3010
Phone: 717-665-2000
Fax: 717-665-2861

www.harringtonhoists.com

